

OWNER'S MANUAL

Impreza

2017



Love. It's what makes a Subaru, a Subaru.



Foreword

Congratulations on choosing a SUBARU vehicle. This Owner's Manual has all the information necessary to keep your SUBARU in excellent condition and to properly maintain the emission control system for minimizing emission pollutants. We urge you to read this manual carefully so that you may understand your vehicle and its operation. For information not found in this Owner's Manual, such as details concerning repairs or adjustments, please contact the SUBARU dealer from whom you purchased your SUBARU or the nearest SUBARU dealer.

The information, specifications and illustrations found in this manual are those in effect at the time of printing. FUJI HEAVY INDUSTRIES LTD. reserves the right to change specifications and designs at any time without prior notice and without incurring any obligation to make the same or similar changes on vehicles previously sold. This Owner's Manual applies to all models and covers all equipment, including factory installed options. Some explanations, therefore may be for equipment not installed in your vehicle.

Please leave this manual in the vehicle at the time of resale. The next owner will need the information found herein.

FUJI HEAVY INDUSTRIES LTD., TOKYO, JAPAN



SUBARU is a registered trademark of FUJI HEAVY INDUSTRIES LTD.

© Copyright 2016 FUJI HEAVY INDUSTRIES LTD.

Vehicle types

This manual describes the following vehicle types.

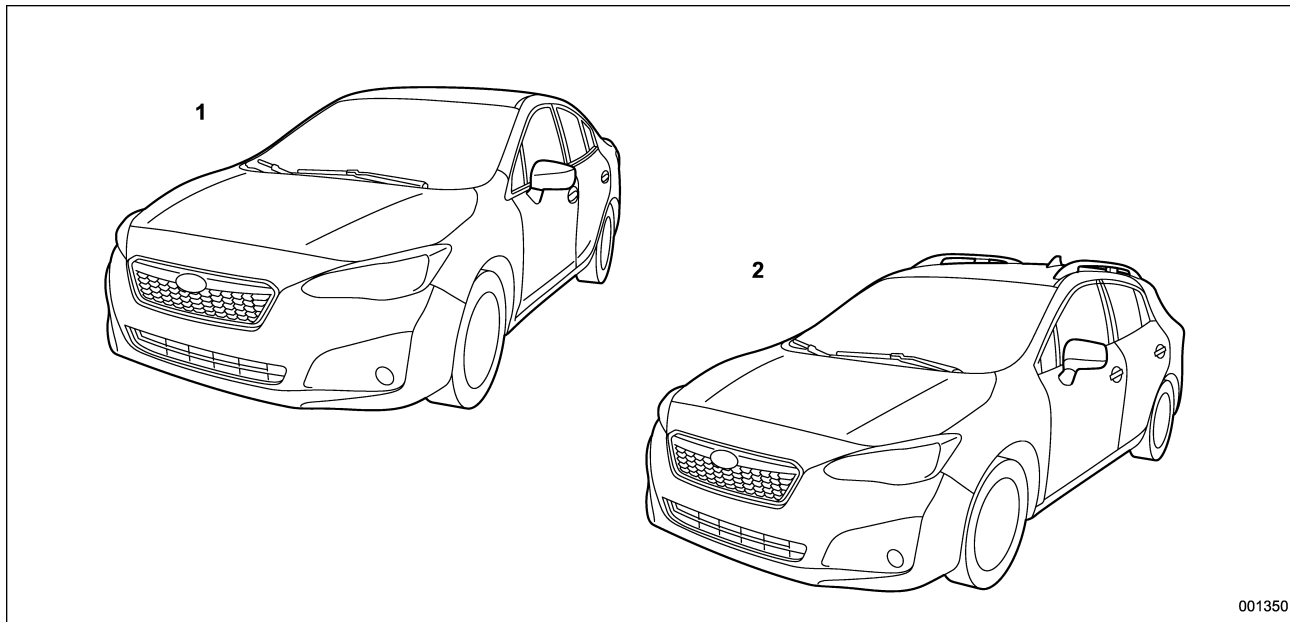

- 1) Sedan
- 2) 5-door models

Warranties

■ Warranties for U.S.A.

SUBARU vehicles distributed by Subaru of America, Inc. and sold at retail by an authorized SUBARU dealer in the United States come with the following warranties:

- **SUBARU Limited Warranties**
- **Federal Emission Control Systems Warranties**
- **California Emissions Control Systems Warranties**

All warranty information, including applicability, details of coverage and exclusions, is in the "Warranty and Maintenance Booklet". Read these warranties carefully.

■ Warranties for Canada

SUBARU vehicles distributed by Subaru Canada, Inc. and sold at retail by an authorized SUBARU dealer in Canada come with the following warranties:

- **SUBARU Limited Warranty**
- **Emission Control System Warranty**

All warranty information, including applicability, details of coverage and exclusions, is in the "Warranty and Service Booklet". Read these warranties carefully.

■ Warranties except for U.S.A. and Canada

All warranty information, including details of coverage and exclusions, is in the "Warranty and Maintenance Booklet". Read these warranties carefully.

How to use this Owner's Manual

■ Using your Owner's Manual

Before you operate your vehicle, carefully read this manual. To protect yourself and extend the service life of your vehicle, follow the instructions in this manual. Failure to observe these instructions may result in serious injury and damage to your vehicle.

This manual is composed of fourteen chapters. Each chapter begins with a brief table of contents, so you can usually tell at a glance if that chapter contains the information you want.

Chapter 1: Seat, seatbelt and SRS airbags

This chapter informs you how to use the seat and seatbelt and contains precautions for the SRS airbags.

Chapter 2: Keys and doors

This chapter informs you how to operate the keys, locks and windows.

Chapter 3: Instruments and controls

This chapter informs you about the operation of instrument panel indicators and how to use the instruments and other switches.

Chapter 4: Climate control

This chapter informs you how to operate the climate control.

Chapter 5: Audio

This chapter informs you about your audio system.

Chapter 6: Interior equipment

This chapter informs you how to operate interior equipment.

Chapter 7: Starting and operating

This chapter informs you how to start and operate your SUBARU.

Chapter 8: Driving tips

This chapter informs you how to drive your SUBARU in various conditions and explains some safety tips on driving.

Chapter 9: In case of emergency

This chapter informs you what to do if you have a problem, such as a flat tire or engine overheating.

Chapter 10: Appearance care

This chapter informs you how to keep your SUBARU looking good.

Chapter 11: Maintenance and service

This chapter informs you when you need to take your SUBARU to the dealer for scheduled maintenance and informs you how to keep your SUBARU running properly.

Chapter 12: Specifications

This chapter informs you about dimensions and capacities of your SUBARU.

Chapter 13: Consumer information and Reporting safety defects

This chapter informs you about Uniform tire quality grading standards and Reporting safety defects.

Chapter 14: Index

This is an alphabetical listing of all that's in this manual. You can use it to quickly find something you want to read.

For models with EyeSight system:

For details about the EyeSight system, refer to the Owner's Manual supplement for the EyeSight system.

■ Safety warnings

You will find a number of WARNINGS, CAUTIONS and NOTES in this manual.

These safety warnings alert you to potential hazards that could result in injury to you or others.

Please read these safety warnings as well as all other portions of this manual carefully in order to gain a better understanding of how to use your SUBARU vehicle safely.

**WARNING**

A WARNING indicates a situation in which serious injury or death could result if the warning is ignored.

**CAUTION**

A CAUTION indicates a situation in which injury or damage to your vehicle, or both, could result if the caution is ignored.

NOTE

A NOTE gives information or suggestions how to make better use of your vehicle.

■ Safety symbol

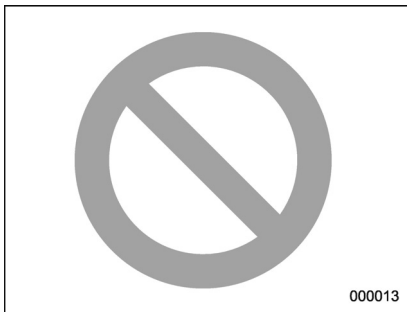

You will find a circle with a slash through it in this manual. This symbol means “Do not”, “Do not do this”, or “Do not let this happen”, depending upon the context.

■ Abbreviation list

You may find several abbreviations in this manual. The meanings of the abbreviations are shown in the following list.









Abbreviation	Meaning
A/C	Air conditioner
ALR/ELR	Automatic locking retractor/ Emergency locking retractor
ABS	Anti-lock brake system
AKI	Anti knock index
ALR	Automatic locking retractor
AWD	All-wheel drive
BSD/RCTA	Blind Spot Detection/Rear Cross Traffic Alert
CVT	Continuously variable trans- mission
DRL	Daytime running light
EBD	Electronic brake force distri- bution
ELR	Emergency locking retractor
GAW	Gross axle weight
GAWR	Gross axle weight rating
GPS	Global positioning system
GVW	Gross vehicle weight
GVWR	Gross vehicle weight rating
INT	Intermittent

Abbreviation	Meaning
LATCH	Lower anchors and tethers for children
LED	Light emitting diode
MIL	Malfunction indicator light
MMT	Methylcyclopentadienyl man- ganese tricarbonyl
MT	Manual transmission
OBD	On-board diagnostics
RAB	Reverse Automatic Braking
RON	Research octane number
SRF	Steering responsive fog lights system
SRH	Steering Responsive Head- light
SRS	Supplemental restraint sys- tem
TIN	Tire identification number
TPMS	Tire pressure monitoring sys- tem

Vehicle symbols

There are some of the symbols you may see on your vehicle.

For warning and indicator lights, refer to "Warning and indicator lights" ¶ 23.

Mark	Name
	WARNING
	CAUTION
	Read these instructions carefully
	Wear eye protection
	Battery fluid contains sulfuric acid
	Keep children away
	Keep flames away
	Prevent explosions

Safety precautions when driving

■ Seatbelt and SRS airbag

WARNING

- All persons in the vehicle must fasten their seatbelts **BEFORE** the vehicle starts to move. Otherwise, the possibility of serious injury becomes greater in the event of a sudden stop or accident.
- To obtain maximum protection in the event of an accident, the driver and all passengers must always wear seatbelts when in the vehicle. The SRS (Supplemental Restraint System) airbag does not do away with the need to fasten seatbelts. In combination with the seatbelts, it offers the best combined protection in case of a serious accident.

Not wearing a seatbelt increases the chance of severe injury or death in a crash even when the vehicle has the SRS airbag.

- The SRS airbags deploy with considerable speed and force. Occupants who are out of proper position when the SRS airbag deploys could suffer very serious injuries. Because the SRS airbag needs enough space for deployment, the driver should always sit upright and well back in the seat as far from the steering wheel as practical while still maintaining full vehicle control and the front passenger should move the seat as far back as possible and sit upright and well back in the seat.

For instructions and precautions, carefully read the following sections.

- For the seatbelt system, refer to "Seatbelts" ¶ 1-11.
- For the SRS airbag system, refer to "*SRS airbag (Supplemental Restraint System airbag)" ¶ 1-38.

■ Child safety

WARNING

- Never hold a child on your lap or in your arms while the vehicle is moving. The passenger cannot protect the child from injury in a collision, because the child will be caught between the passenger and objects inside the vehicle.
- While riding in the vehicle, infants and small children should always be seated in the REAR seat in an infant or child restraint system which is appropriate for the child's age, height and weight. If a child is too big for a child restraint system, the child should sit in the REAR seat and be restrained using the seatbelts. According to accident statistics, children are safer when properly restrained in the rear seating positions than in the front seating positions. Never allow a child to stand up or kneel on the seat.
- Place children in the REAR seat properly restrained at all times in a child restraint device or in a seatbelt. The SRS airbag deploys

with considerable speed and force and can injure or even kill children, especially if they are not restrained or improperly restrained. Because children are lighter and weaker than adults, their risk of being injured from deployment is greater.

- NEVER INSTALL A FORWARD OR REARWARD FACING CHILD SEAT IN THE FRONT SEAT. DOING SO RISKS SERIOUS INJURY OR DEATH TO THE CHILD BY PLACING THE CHILD'S HEAD TOO CLOSE TO THE SRS AIRBAG.
- Always turn the child safety locks to the "LOCK" position when children sit in the rear seat. Serious injury could result if a child accidentally opens the door and falls out. Refer to "Child safety locks" [☞ 2-30](#).
- Always lock the passenger's windows using the lock switch when children are riding in the vehicle. Failure to follow this procedure could result in injury to a child operating the power window. Refer to "Windows" [☞ 2-30](#).
- Never leave unattended children,

adults or animals in the vehicle. They could accidentally injure themselves or others through inadvertent operation of the vehicle. Also, on hot or sunny days, temperature in a closed vehicle could quickly become high enough to cause severe or possibly fatal injuries to them.

- Help prevent children, adults or animals from locking themselves in the trunk. On hot or sunny days, the temperature in the trunk could quickly become high enough to cause death or serious heat-related injuries including brain damage to anyone locked inside, particularly for small children.
- When leaving the vehicle, close all windows and lock all doors. Also make certain that the trunk is closed.

For instructions and precautions, carefully read the following sections.

- For the seatbelt system, refer to "Seatbelts" [☞ 1-11](#).
- For the child restraint system, refer to "Child restraint systems" [☞ 1-25](#).
- For the SRS airbag system, refer to

“*SRS airbag (Supplemental Restraint System airbag)” 1-38.

■ Engine exhaust gas (carbon monoxide)

WARNING

- Never inhale engine exhaust gas. Engine exhaust gas contains carbon monoxide, a colorless and odorless gas which is dangerous, or even lethal, if inhaled.
- Always properly maintain the engine exhaust system to prevent engine exhaust gas from entering the vehicle.
- Never run the engine in a closed space, such as a garage, except for the brief time needed to drive the vehicle in or out of it.
- Avoid remaining in a parked vehicle for a lengthy time while the engine is running. If that is unavoidable, then use the ventilation fan to force fresh air into the vehicle.
- Always keep the front ventilator inlet grille free from snow, leaves or other obstructions to ensure that the ventilation system al-

ways works properly.

- If at any time you suspect that exhaust fumes are entering the vehicle, have the problem checked and corrected as soon as possible. If you must drive under these conditions, drive only with all windows fully open.
- Keep the trunk lid or rear gate closed while driving to prevent exhaust gas from entering the vehicle.

■ Drinking and driving

WARNING

Drinking and then driving is very dangerous. Alcohol in the bloodstream delays your reaction time and impairs your perception, judgment and attentiveness. If you drive after drinking – even if you drink just a little – it will increase the risk of being involved in a serious or fatal accident, injuring or killing yourself, your passengers and others. In addition, if you are injured in the accident, alcohol may increase the severity of that injury.

Please don't drink and drive.

Drunken driving is one of the most frequent causes of accidents. Since alcohol affects all people differently, you may have consumed too much alcohol to drive safely even if the level of alcohol in your blood is below the legal limit. The safest thing you can do is never drink and drive. However if you have no choice but to drive, stop drinking and sober up completely before getting behind the wheel.

■ Drugs and driving

WARNING

There are some drugs (over the counter and prescription) that can delay your reaction time and impair your perception, judgment and attentiveness. If you drive after taking them, it may increase your, your passengers' and other persons' risk of being involved in a serious or fatal accident.

If you are taking any drugs, check with your doctor or pharmacist or read the literature that accompanies the medication to determine if the drug you are taking can impair your driving ability. Do not drive after taking any medications that can make you drowsy or otherwise affect your ability to safely operate a motor vehicle. If

you have a medical condition that requires you to take drugs, please consult with your doctor.

Never drive if you are under the influence of any illicit mind-altering drugs. For your own health and well-being, we urge you not to take illegal drugs in the first place and to seek treatment if you are addicted to those drugs.

■ Driving when tired or sleepy

WARNING

When you are tired or sleepy, your reaction time will be delayed and your perception, judgment and attentiveness will be impaired. If you drive when tired or sleepy, your, your passengers' and other persons' chances of being involved in a serious accident may increase.

Please do not continue to drive but instead find a safe place to rest if you are tired or sleepy. On long trips, you should make periodic rest stops to refresh yourself before continuing on your journey. When possible, you should share the driving with others.

■ Modification of your vehicle

CAUTION

Your vehicle should not be modified other than with genuine SUBARU parts and accessories. Other types of modifications could affect its performance, safety or durability, and may even violate governmental regulations. In addition, damage or performance problems resulting from modification may not be covered under warranties.

■ Use of cell phones/texting and driving

CAUTION

Do not talk on a cell phone or text while driving; it may distract your attention from driving and lead to an accident. If you use a cell phone to talk or text, first pull off the road and park in a safe place. In some States/Provinces, it may be lawful to talk on a phone while driving, but only if the phone is hands-free.

■ Driving vehicles equipped with navigation system

WARNING

Do not allow the monitor to distract your attention from driving. Also, do not operate the controls of the navigation system while driving. The loss of attention to driving could lead to an accident. If you wish to operate the controls of the navigation system, first take the vehicle off the road and stop it in a safe location.

■ Driving with pets

Unrestrained pets can interfere with your driving and distract your attention from driving. In a collision or sudden stop, unrestrained pets or cages can be thrown around inside the vehicle and hurt you or your passengers. Besides, the pets can be hurt under these situations. It is also for their own safety that pets should be properly restrained in your vehicle. Restrain a pet with a special traveling harness which can be secured to the rear seat with a seatbelt or use a pet carrier which can be secured to the rear seat by routing a seatbelt through the carrier's

handle. Never restrain pets or pet carriers in the front passenger's seat. For further information, consult your veterinarian, local animal protection society or pet shop.

■ Tire pressures

Check and, if necessary, adjust the pressure of each tire (including the spare) at least once a month and before any long journey.

Check the tire pressure when the tires are cold. Use a pressure gauge to adjust the tire pressures to the values shown on the tire placard. For detailed information, refer to "Tires and wheels" 11-21.



WARNING

Driving at high speeds with excessively low tire pressures can cause the tires to deform severely and to rapidly become hot. A sharp increase in temperature could cause tread separation, and destruction of the tires. The resulting loss of vehicle control could lead to an accident.

■ Attaching accessories



WARNING

- Do not attach any accessories, labels or stickers (other than properly placed inspection stickers) to the windshield. Such items may obstruct your view.
- If it is necessary to attach an accessory (such as an electronic toll collection (ETC) device or security pass) to the windshield, consult your SUBARU dealer for details on the proper location.

General information

■ California proposition 65 warning



WARNING

Engine exhaust, some of its constituents, and certain vehicle components contain or emit chemicals known to the State of California to cause cancer and birth defects or other reproductive harm. In addition, certain fluids in vehicles and certain components of product wear contain or emit chemicals known to the State of California to cause cancer and birth defects or other reproductive harm.

■ California Perchlorate Advisory

Certain vehicle components such as air-bag modules, seatbelt pretensioners and keyless entry transmitter batteries may contain perchlorate material. Special handling may apply for service or vehicle end of life disposal. See www.dtsc.ca.gov/hazardouswaste/perchlorate.

■ Noise from under the vehicle

NOTE

You may hear a noise from under the vehicle approximately 5 to 10 hours after the ignition switch is turned to the “LOCK”/“OFF” position. However, this does not indicate a malfunction. This noise is caused by the operation of the fuel evaporation leakage checking system and the operation is normal. The noise will stop after approximately 15 minutes.

■ Event data recorder

This vehicle is equipped with an event data recorder (EDR). The main purpose of an EDR is to record, in certain crash or near crash-like situations, such as an air bag deployment or hitting a road obstacle, data that will assist in understanding how a vehicle's systems performed. The EDR is designed to record data related to vehicle dynamics and safety systems for a short period of time, typically 30 seconds or less. The EDR in this vehicle is designed to record such data as:

- How various systems in your vehicle were operating;
- Whether or not the driver and passenger safety belts were buckled/fastened;
- How far (if at all) the driver was

depressing the accelerator and/or brake pedal; and,

- How fast the vehicle was traveling.

These data can help provide a better understanding of the circumstances in which crashes and injuries occur. NOTE: EDR data are recorded by your vehicle only if a non-trivial crash situation occurs; no data are recorded by the EDR under normal driving conditions and no personal data (e.g., name, gender, age, and crash location) are recorded. However, other parties, such as law enforcement, could combine the EDR data with the type of personally identifying data routinely acquired during a crash investigation.

To read data recorded by an EDR, special equipment is required, and access to the vehicle or the EDR is needed. In addition to the vehicle manufacturer, other parties, such as law enforcement, that have the special equipment, can read the information if they have access to the vehicle or the EDR.

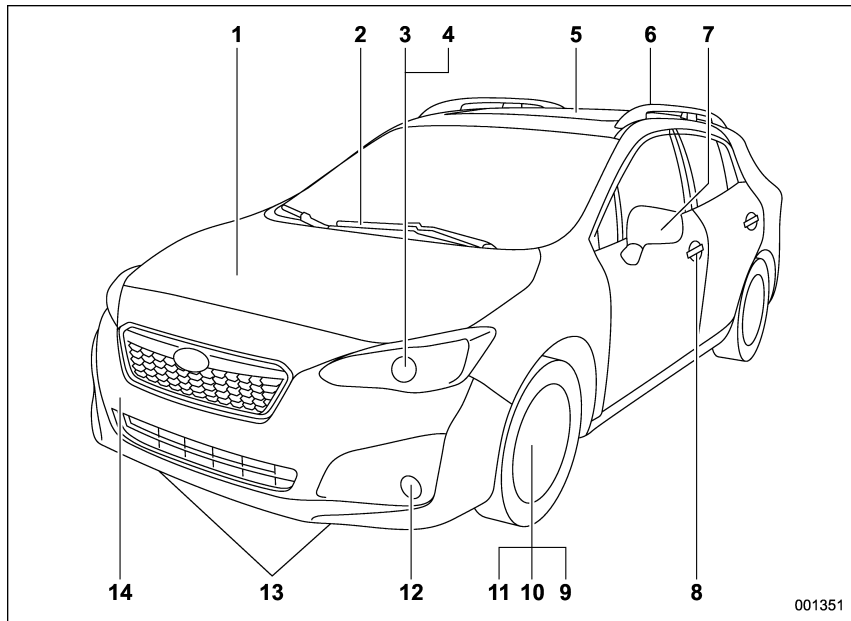

Table of contents

<i>Seat, seatbelt and SRS airbags</i>	1
<i>Keys and doors</i>	2
<i>Instruments and controls</i>	3
<i>Climate control</i>	4
<i>Audio</i>	5
<i>Interior equipment</i>	6
<i>Starting and operating</i>	7
<i>Driving tips</i>	8
<i>In case of emergency</i>	9
<i>Appearance care</i>	10
<i>Maintenance and service</i>	11
<i>Specifications</i>	12
<i>Consumer information and Reporting safety defects</i>	13
<i>Index</i>	14

Illustrated index

■ Exterior



- 1) Engine hood (page 11-5)
- 2) Wiper (page 3-77)
- 3) Headlight (page 3-66)
- 4) Replacing bulbs (page 11-37)
- 5) Moonroof (page 2-37)
- 6) Roof rails (page 8-12)
- 7) Outside mirror (page 3-87)
- 8) Door locks (page 2-23)
- 9) Tire pressure (page 11-23)
- 10) Flat tires (page 9-6)
- 11) Snow tires (page 8-8)
- 12) Fog light (page 3-73)
- 13) Tie-down hooks (page 9-14)
- 14) Towing hook (page 9-14)

001351

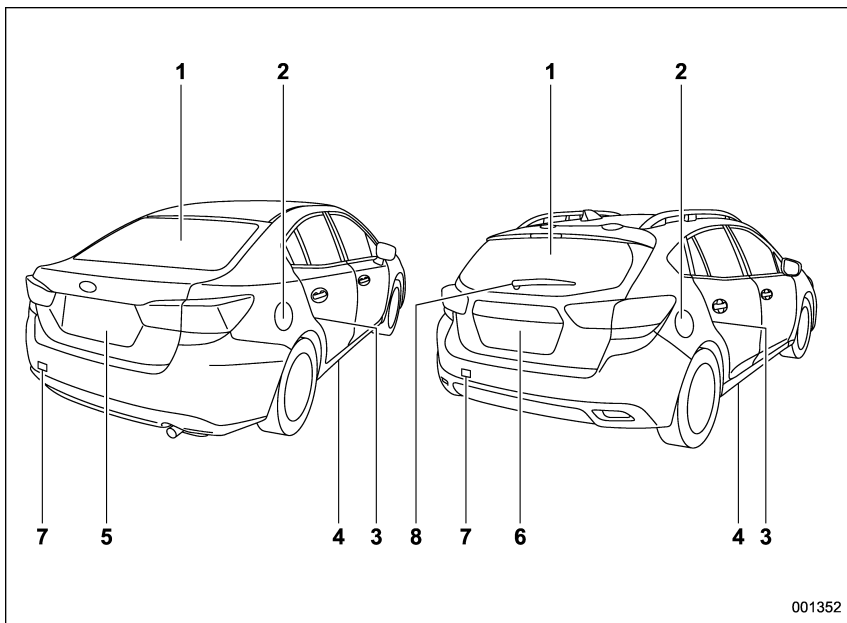

- 1) Rear window defogger (page 3-88)
- 2) Fuel filler lid and cap (page 7-4)
- 3) Child safety locks (page 2-30)
- 4) Tie-down hole (page 9-14)
- 5) Trunk lid (page 2-33)
- 6) Rear gate (page 2-35)
- 7) Towing hook (page 9-14)
- 8) Rear window wiper (page 3-78)

■ Interior

▼ Passenger compartment area

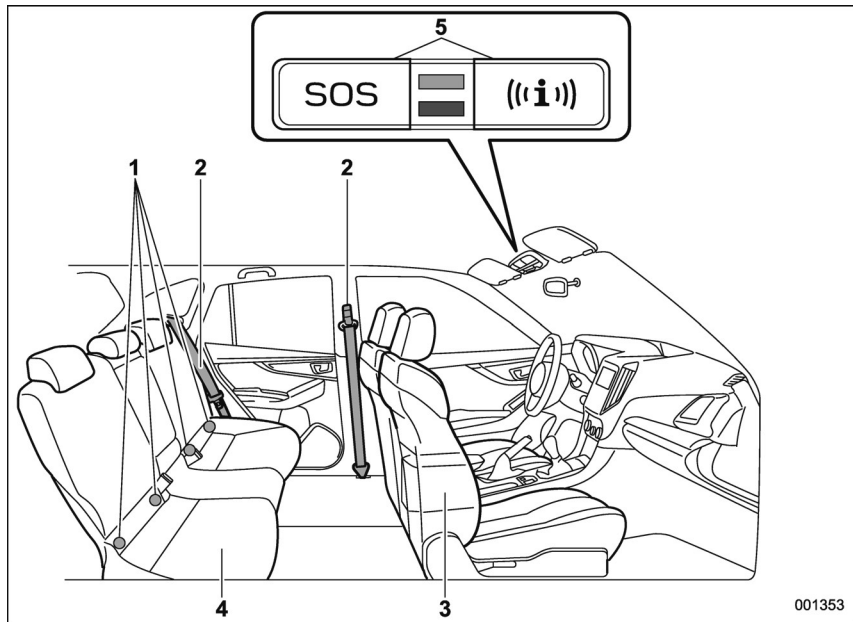

- 1) Lower anchorages for child restraint system (page 1-33)
- 2) Seatbelt (page 1-11)
- 3) Front seat (page 1-2)
- 4) Rear seat (page 1-2)
- 5) Buttons for SUBARU STARLINK

NOTE

For U.S.-spec. models with SUBARU STARLINK: Refer to the Owner's Manual supplement for SUBARU STARLINK.

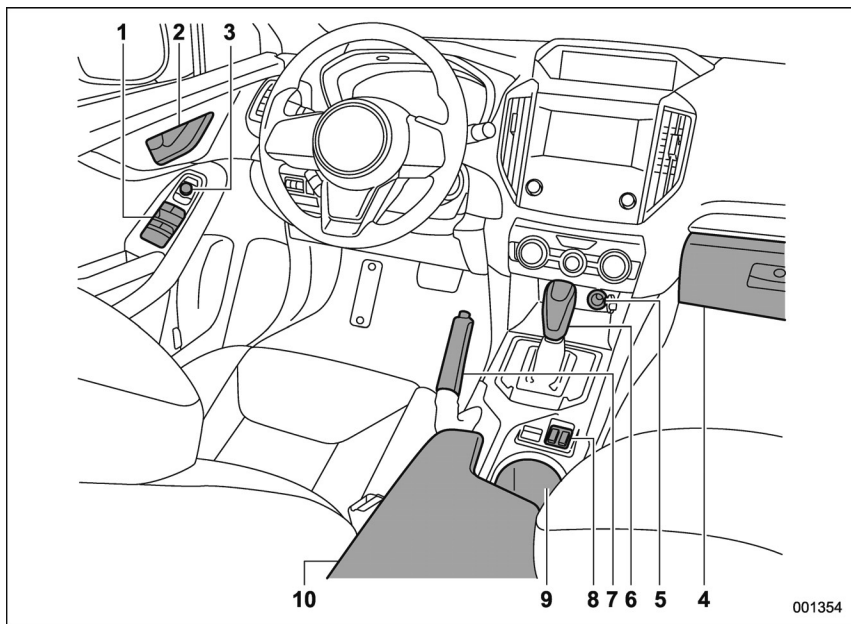

- 1) Power windows (page 2-30)
- 2) Door locks (page 2-23)
- 3) Outside mirror switch (page 3-87)
- 4) Glove box (page 6-5)
- 5) Front power supply socket (page 6-7)
- 6) Shift lever (MT models) (page 7-21)/
Select lever (CVT models) (page 7-23)
- 7) Parking brake lever (page 7-39)
- 8) Seat heater switches (page 1-10)
- 9) Cup holder (page 6-6)
- 10) Center console (page 6-6)

■ Instrument panel

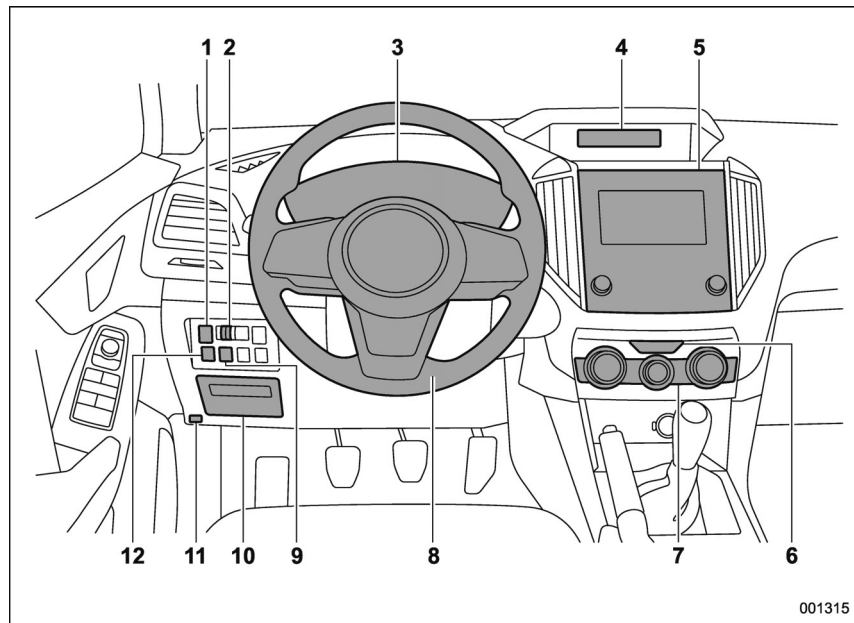

- 1) Steering responsive fog lights OFF switch (page 3-73)/Steering Responsive Headlight off switch (page 3-72)
- 2) Illumination brightness control (page 3-12)
- 3) Combination meter (page 3-9)
- 4) Type A multi-function display (black and white) (page 3-43)/Type B multi-function display (color LCD) (page 3-48)
- 5) Audio*
- 6) Hazard warning flasher switch (page 3-8)
- 7) Climate control (page 4-2)
- 8) Tilt/Telescopic steering (page 3-90)
- 9) BSD/RCTA OFF switch (page 7-48)
- 10) Fuse box (page 11-35)
- 11) Hood lock release knob (page 11-5)
- 12) Vehicle Dynamics Control OFF switch (page 7-36)

*: For details about how to use the audio and navigation system (if equipped), refer to the separate navigation/audio Owner's Manual.

NOTE

For models with the EyeSight system: Refer to the Owner's Manual supplement for the EyeSight system.

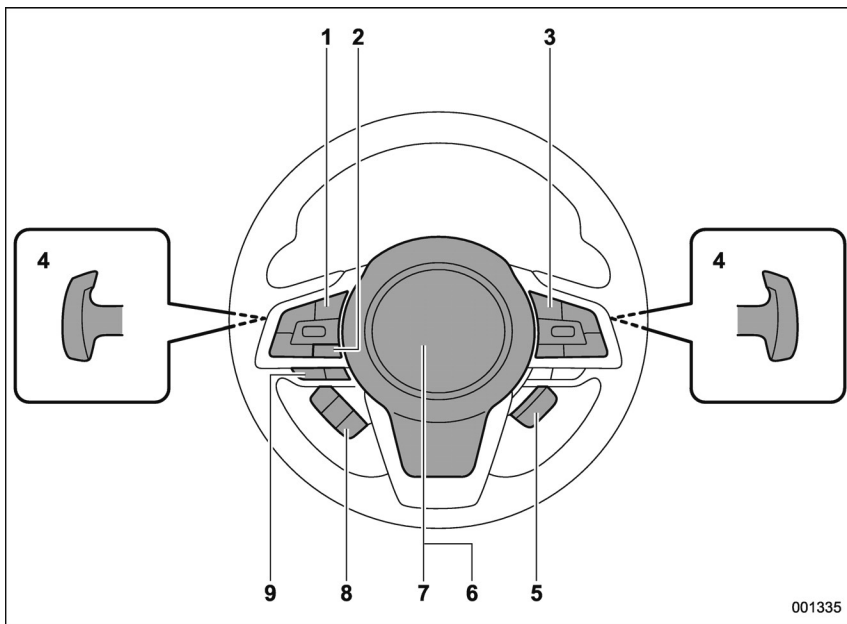

- 1) Audio control switches*
- 2) INFO button for type A multi-function display (black and white) (page 3-43)/
INFO button for type B multi-function display (color LCD) (page 3-48)
- 3) Cruise control (page 7-44)
- 4) Shift paddle (page 7-26)
- 5) Heated Steering Wheel switch (page 3-90)
- 6) SRS airbag (page 1-38)
- 7) Horn (page 3-91)
- 8) Combination meter display (color LCD) control switches (page 3-34)
- 9) Talk switch for voice command system*/
Hands-free phone switches*

*: For details about how to use the switches, refer to the separate navigation/audio Owner's Manual.

■ Light control and wiper control levers/switches

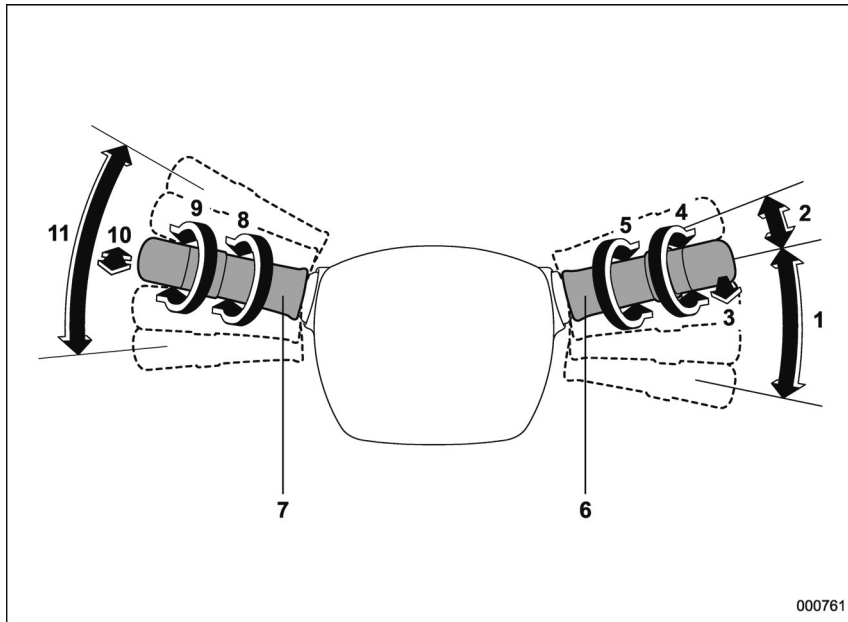

- 1) Windshield wiper (page 3-75)
- 2) Mist (page 3-77)
- 3) Windshield washer (page 3-77)
- 4) Rear window wiper and washer switch (page 3-78)
- 5) Wiper intermittent time control switch (page 3-77)
- 6) Windshield wiper and washer switches (page 3-77)
- 7) Light control switch (page 3-66)
- 8) Fog light switch (page 3-73)
- 9) Headlight ON/OFF/AUTO (page 3-66)
- 10) Headlight flasher High/Low beam change (page 3-68)
- 11) Turn signal lever (page 3-75)

000761

■ Combination meter

▼ U.S.-spec. models (type A)

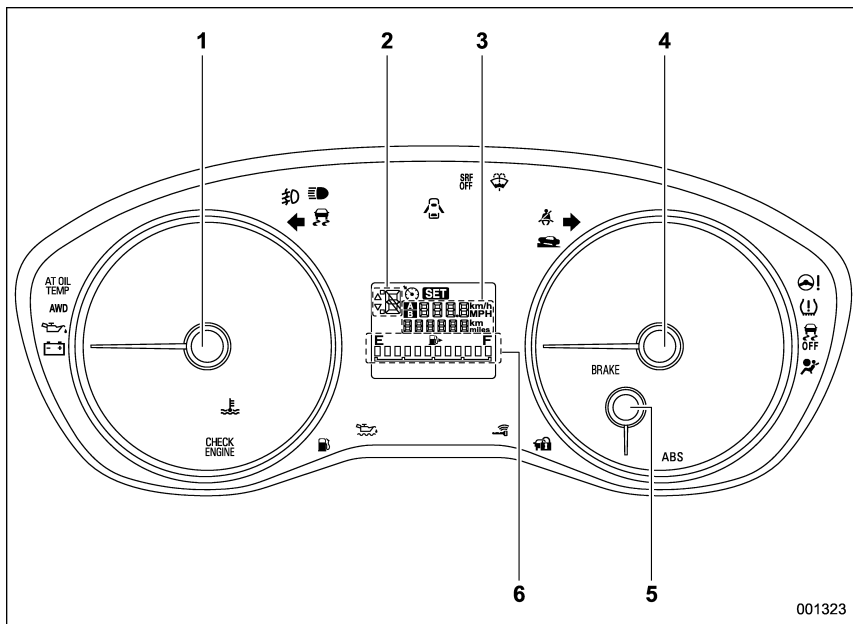

- 1) Tachometer (page 3-9)
- 2) Select lever/gear position indicator (page 3-31)
- 3) Trip meter and odometer (page 3-9)
- 4) Speedometer (page 3-9)
- 5) ECO gauge (page 3-11)
- 6) Fuel gauge (page 3-10)

The illustration above is a typical example. For some models, the combination meter may be slightly different than that shown in the illustration.

▼ U.S.-spec. models (type B)

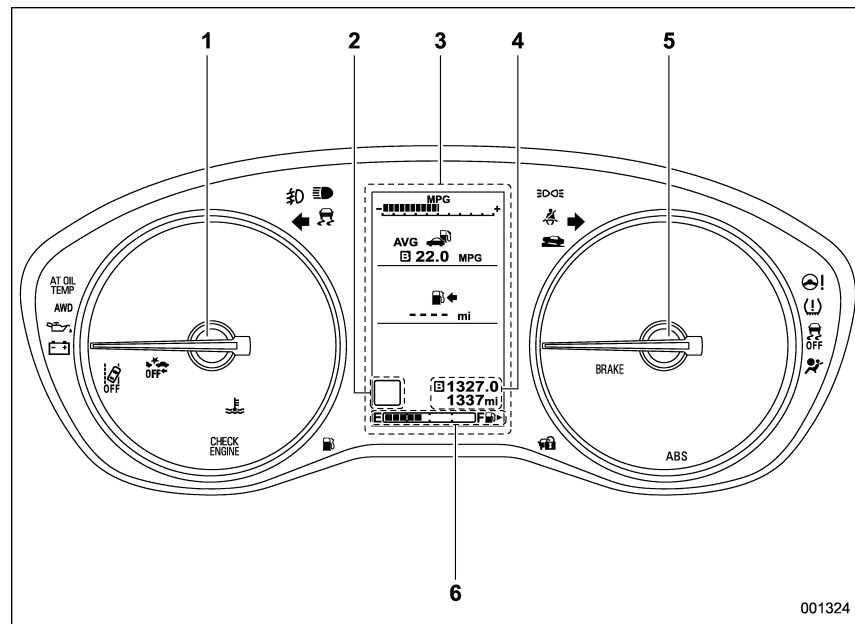

- 1) Tachometer (page 3-9)
- 2) Select lever/gear position indicator (page 3-31)
- 3) Combination meter display (color LCD) (page 3-34)
- 4) Trip meter and odometer (page 3-9)
- 5) Speedometer (page 3-9)
- 6) Fuel gauge (page 3-10)

The illustration above is a typical example. For some models, the combination meter may be slightly different than that shown in the illustration.

▼ Except U.S.-spec. models (type A)

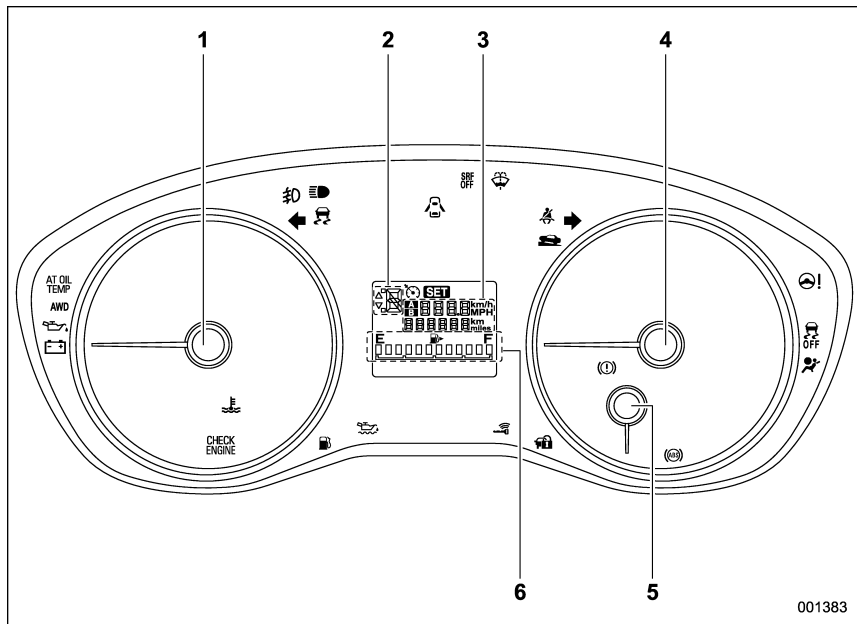

- 1) Tachometer (page 3-9)
- 2) Select lever/gear position indicator (page 3-31)
- 3) Trip meter and odometer (page 3-9)
- 4) Speedometer (page 3-9)
- 5) ECO gauge (page 3-11)
- 6) Fuel gauge (page 3-10)

The illustration above is a typical example. For some models, the combination meter may be slightly different than that shown in the illustration.

▼ Except U.S.-spec. models (type B)

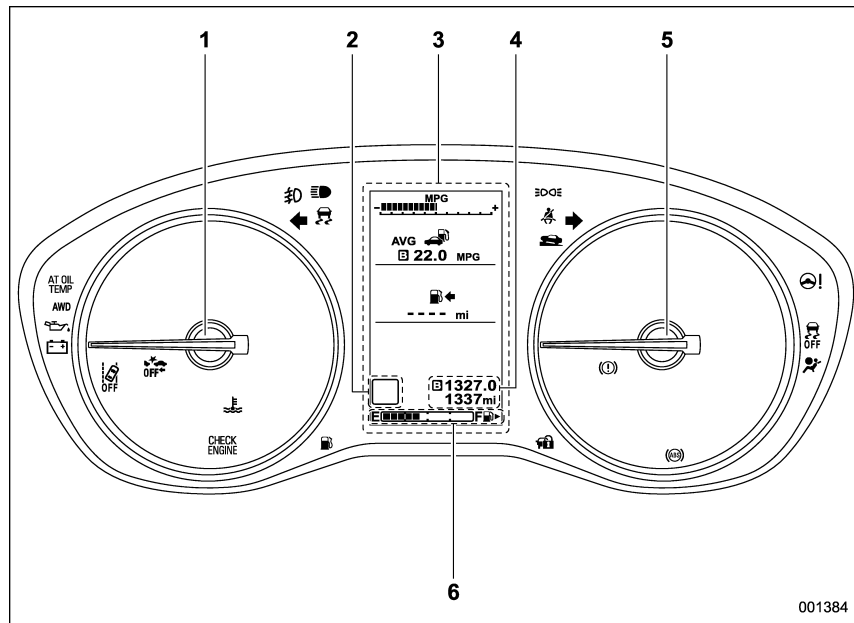



















- 1) Tachometer (page 3-9)
- 2) Select lever/gear position indicator (page 3-31)
- 3) Combination meter display (color LCD) (page 3-34)
- 4) Trip meter and odometer (page 3-9)
- 5) Speedometer (page 3-9)
- 6) Fuel gauge (page 3-10)

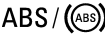
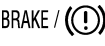







The illustration above is a typical example. For some models, the combination meter may be slightly different than that shown in the illustration.







001384

■ Warning and indicator lights

Mark	Name	Page
	Seatbelt warning light	3-14
	Front passenger's seatbelt warning light	3-14
	SRS airbag system warning light	3-15
	Front passenger's frontal airbag ON indicator	3-16
	Front passenger's frontal airbag OFF indicator	3-16
	CHECK ENGINE warning light/Malfunction indicator light	3-16
	Coolant temperature low indicator light/ Coolant temperature high warning light	3-17
	Charge warning light	3-18
	Oil pressure warning light	3-18
	Engine oil level warning light	3-18

Mark	Name	Page
	AT OIL TEMP warning light (CVT models)	3-19
	ABS warning light	3-21
	Brake system warning light	3-21
	Door open warning light	3-23
	AWD warning light (CVT models)	3-23
	Power steering warning light	3-23
	Hill start assist warning light/Hill start assist OFF indicator light	3-23
	Vehicle Dynamics Control warning light/ Vehicle Dynamics Control operation indicator light	3-24
	Vehicle Dynamics Control OFF indicator light	3-25
	Turn signal indicator lights	3-31

Mark	Name	Page
	High beam indicator light	3-31
	High beam assist indicator light (green) (if equipped)	3-31
	High Beam Assist warning indicator (yellow) (if equipped)	3-31
	Automatic headlight beam leveler warning light (if equipped)	3-32
	Steering Responsive Headlight warning light/Steering Responsive Headlight OFF indicator light (if equipped)	3-72
	Front fog light indicator light (if equipped)	3-32
	Access key warning indicator (if equipped)	3-25
	Security indicator light	3-30
	Headlight indicator light (if equipped)	3-32
	Cruise control indicator light (if equipped)	3-32

Mark	Name	Page
	Cruise control set indicator light (if equipped)	3-32
	Low fuel warning light	3-22
	Low tire pressure warning light (U.S.-spec. models)	3-19
	Windshield washer fluid warning light	3-19
SRF OFF	Steering responsive fog lights warning indicator/Steering responsive fog lights OFF indicator (if equipped)	3-32
	BSD/RCTA warning indicator (if equipped)	3-33
	BSD/RCTA OFF indicator (if equipped)	3-33
RAB	RAB warning indicator (if equipped)	3-33
RAB OFF	RAB OFF indicator (if equipped)	3-33
	Icy road surface warning indicator (if equipped)	3-33

Function settings

A SUBARU dealer can change the settings of the functions shown in the following table to meet your personal requirements. Contact the nearest SUBARU dealer for details. If your vehicle is equipped with a combination meter display (color LCD)*, audio unit or navigation unit*, the settings for some of these functions can be changed using the display. For details, refer to “Combination meter display (color LCD)” 3-34.

*: if equipped

Item	Function	Possible settings	Default setting
Alarm system	Alarm system	Operation/Non-operation	Operation
	Monitoring start delay time (after closure of doors)	0 seconds/30 seconds	30 seconds
	Dome light, cargo area light, and map lights illumination	ON/OFF	OFF
Keyless Access (if equipped)	Hazard warning flasher	Operation/Non-operation	Operation
	Audible signal	Operation/Non-operation	Operation
	Audible signal volume	Level 1 to 7	Level 5
	Door unlock selection function (driver's door unlock)	Driver's door only/All doors	Driver's door only
	Door unlock selection function (rear gate unlock) (5-door models)	Rear gate only/All doors	Rear gate only
	Trunk open without key (sedan)	ON/OFF	ON
Remote keyless entry system	Hazard warning flasher	Operation/Non-operation	Operation
	Audible signal	Operation/Non-operation	Operation
	Audible signal volume	Level 1 to 7	Level 5
Key lock-in prevention	Key lock-in prevention	Operation/Non-operation	Operation
Defogger and deicer system for models with the automatic climate control system	Rear window defogger, outside mirror defogger and windshield wiper deicer	Operation for 15 minutes/ Continuous operation	Operation for 15 minutes

Item	Function	Possible settings	Default setting
Dome light/Map lights/Cargo area light (5-door models)	Operation of dome light/map light/cargo area light OFF delay timer	OFF/10 seconds/20 seconds/30 seconds	30 seconds
Battery drainage prevention function	Battery drainage prevention function	Operation/Non-operation	Operation
Seatbelt warning	Sounds a chime while driving	Operation/Non-operation	Operation
Auto on/off headlights (if equipped)	Sensitivity of the operation of the auto on/off headlights	Low/Normal/High/Very high	High
Welcome lighting function (if equipped)	Welcome lighting function (when approaching)	OFF/30 seconds/60 seconds/90 seconds	30 seconds
	Welcome lighting function (when exiting)	OFF/30 seconds/60 seconds/90 seconds	30 seconds
Reverse gear interlocked rear wiper (5-door models)	Reverse gear interlocked rear wiper operation	Operation/Non-operation	U.S.-spec. models: Non-operation Other models: Operation
One-touch lane changer	Operation of the one-touch lane changer	Operation/Non-operation	Operation
Auto dimmer cancel (if equipped)	Sensitivity of the operation of the auto dimmer cancel	OFF/Min/Low/Mid/Hi/Max	Mid
High beam assist function (if equipped)	High beam assist function	Operation/Non-operation	Operation

Seats	1-2	Where to place a child restraint system	1-26
Safety tips.....	1-2	Choosing a child restraint system	1-28
Front seats	1-5	Installing child restraint systems with ALR/ELR seatbelt	1-28
Rear seats	1-6	Installing a booster seat.....	1-32
Head restraint	1-8	Installation of child restraint systems by use of lower and tether anchorages (LATCH)	1-33
Seat heater (if equipped)	1-10	Top tether anchorages	1-36
Safety precautions	1-10	*SRS airbag (Supplemental Restraint System airbag).....	1-38
Operation.....	1-11	General precautions regarding SRS airbag system	1-38
Seatbelts	1-11	General precautions regarding SRS airbag system for accessories and any objects	1-40
Seatbelt safety tips.....	1-11	General precautions regarding SRS airbag system and children	1-42
Emergency Locking Retractor (ELR)	1-13	Components.....	1-45
Automatic Locking Retractor/Emergency Locking Retractor (ALR/ELR)	1-13	SUBARU advanced frontal airbag system	1-47
Seatbelt warning light and chime	1-14	SRS side airbag and SRS curtain airbag.....	1-58
Fastening the seatbelt	1-14	SRS airbag system monitors	1-66
Seatbelt maintenance	1-20	SRS airbag system servicing	1-67
Seatbelt pretensioners.....	1-20	Precautions against vehicle modification	1-68
Seatbelt with shoulder belt pretensioner	1-21	How to contact the vehicle manufacturer concerning modifications for persons with disabilities that may affect the advanced airbag system	1-69
Seatbelt with shoulder belt and lap belt pretensioners.....	1-22		
System monitors	1-24		
System servicing.....	1-24		
Precautions against vehicle modification	1-24		
Child restraint systems.....	1-25		
Safety tips for installing child restraint systems	1-26		

Seats

■ Safety tips

▼ Safety tips for seat

WARNING

- Never adjust the seat while driving to avoid loss of vehicle control and personal injury.
- Before adjusting the seat, make sure the hands and feet of rear seat passengers and cargo are clear of the adjusting mechanism.
- After adjusting the seat, push it slightly to make sure it is securely locked. If the seat is not securely locked, it may move or the seatbelt may not operate properly.
- Do not put objects under the front seats. They may interfere with front seat locking and cause an accident.
- Seatbelts provide maximum restraint when the occupant sits well back and upright in the seat. To reduce the risk of sliding under the seatbelt in a collision, the front seatbacks should be

always used in the upright position while the vehicle is running. If the front seatbacks are not used in the upright position in a collision, the risk of sliding under the lap belt and of the lap belt sliding up over the abdomen will increase, and both can result in serious internal injury or death.

- The SRS airbags deploy with considerable speed and force. Occupants who are out of proper position when the SRS airbag deploys could suffer very serious injuries. Because the SRS airbag needs enough space for deployment, the driver should always sit upright and well back in the seat as far from the steering wheel as practical while still maintaining full vehicle control and the front passenger should move the seat as far back as possible and sit upright and well back in the seat.



100082

WARNING

Place children in the rear seat properly restrained at all times. The SRS airbag deploys with considerable speed and force and can injure or even kill children, especially if they are not restrained or improperly restrained. Because children are lighter and weaker than adults, their risk of being injured from deployment is greater. For that reason, we strongly recommend that ALL children (including those in child seats and those that have outgrown child restraint devices) sit in the REAR seat properly restrained at all times in a child restraint device or in a seatbelt,

whichever is appropriate for the child's age, height and weight. Secure ALL types of child restraint devices (including forward facing child seat) in the REAR seats at all times.

NEVER INSTALL A FORWARD OR REARWARD FACING CHILD SEAT IN THE FRONT SEAT. DOING SO RISKS SERIOUS INJURY OR DEATH TO THE CHILD BY PLACING THE CHILD'S HEAD TOO CLOSE TO THE SRS AIRBAG.

According to accident statistics, children are safer when properly restrained in the rear seating positions than in the front seating positions. For instructions and precautions concerning child restraint systems, refer to "Child restraint systems" 1-25.

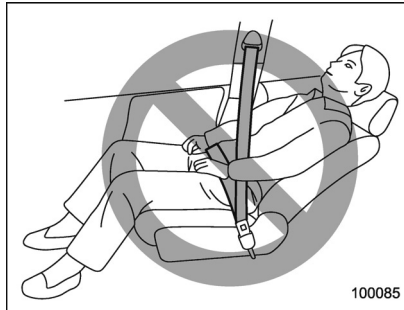

⚠ WARNING

To prevent the passenger from sliding under the seatbelt in the event of a collision, always put the seatback in the upright position while the vehicle is in motion. Also, do not place objects such as cushions between the passenger and the seatback. If you do so, the risk of sliding under the lap belt and of the lap belt sliding up over the abdomen will increase, and both can result in serious internal injury or death.

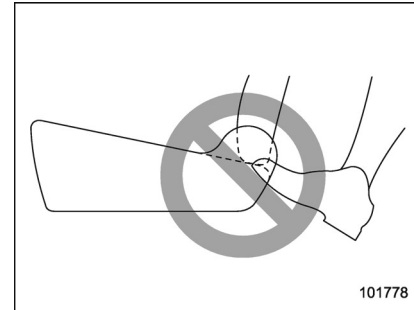

⚠ WARNING

Do not let rear passengers rest their feet between the front seatback and seat cushion. Doing so may lead to defective operation of the following systems and could result in serious injury.

- Occupant detection system
- SRS side airbag
- Seat heater (if equipped)
- Power seat (if equipped)

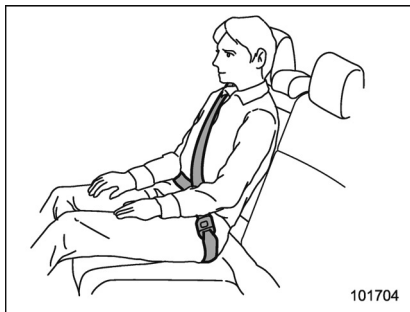

WARNING

Seatbelts provide maximum restraint when the occupant sits well back and upright in the seat. Do not put cushions or any other materials between occupants and seatbacks or seat cushions. If you do so, the risk of sliding under the lap belt and of the lap belt sliding up over the abdomen will increase, and both can result in serious internal injury or death.

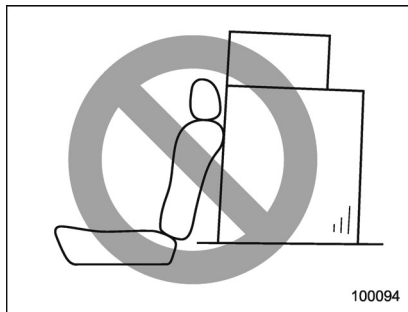

WARNING

Never stack luggage or other cargo higher than the top of the seatback because it could tumble forward and injure passengers in the event of a sudden stop or accident.

▼ Safety tips for head restraint

WARNING

- Never drive the vehicle with the head restraints removed because they are designed to reduce the risk of serious neck injury in the event that the vehicle is struck from the rear. Also, never install the head restraints the opposite way round. Doing so will prevent the head restraints from functioning as intended. Therefore, when you remove the head restraints, you must reinstall all head restraints correctly to protect vehicle occupants.
- All occupants, including the driver, should not operate a vehicle or sit in a vehicle's seat until the head restraints are placed in their proper positions in order to minimize the risk of neck injury in the event of a crash.

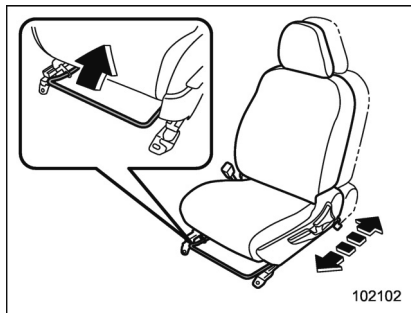
■ Front seats**▼ Manual seat (if equipped)****▽ Forward and backward adjustment**

Pull the lever upward and slide the seat to the desired position. Then release the lever and try to move the seat back and forth to make sure that it is securely locked into place.

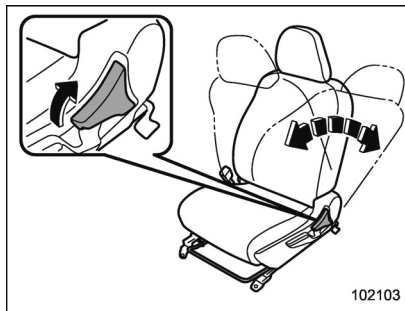
▽ Reclining the seatback

Pull the reclining lever up and adjust the seatback to the desired position. Then release the lever and make sure the seatback is securely locked into place.

The seatback placed in a reclined position can spring back upward with force when the lever is pulled. While operating the lever to return the seatback, hold the seatback lightly so that it may be raised back gradually.

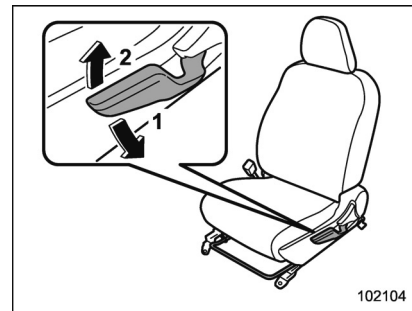
▽ Seat height adjustment (driver's seat)

- 1) When the lever is pushed down, the seat is lowered.
- 2) When the lever is pulled up, the seat rises.

The height of the seat can be adjusted by moving the seat adjustment lever up and down.

▼ **Power seat (driver's seat – if equipped)**

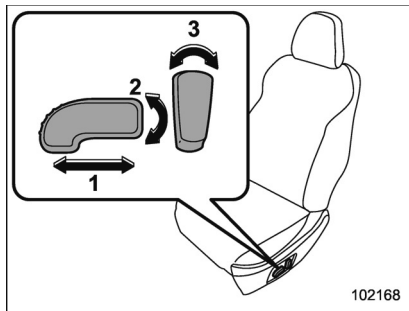

- 1) **Seat position forward/backward control switch**
To adjust the seat forward or backward, move the control switch forward or backward. During forward/backward adjustment of the seat, you cannot adjust the seat cushion height.
- 2) **Seat height control switch**
To adjust the seat height, pull up or push down the rear end of the control switch.
- 3) **Seatback angle (reclining) control switch**
To adjust the angle of the seatback, move the control switch.

■ **Rear seats**

▼ **Armrest (if equipped)**

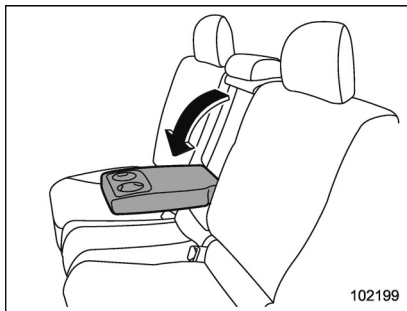

To lower the armrest, pull on the top edge of the armrest.

WARNING

To avoid serious injury, passengers must never be allowed to sit on the center armrest.

▼ **Folding down the rear seatback**

WARNING

- When you fold down the seatback, check that there are no passengers or objects on the rear seat. Not doing so creates a risk of injury or property damage if the seatback suddenly folds down.
- Never allow passengers to ride on the folded rear seatback or in the cargo area or trunk. Doing so may result in serious injury or death.
- Secure all objects and especially long items properly to prevent them from being thrown around inside the vehicle and causing serious injury during a sudden stop, a sudden steering maneuver or a rapid acceleration.

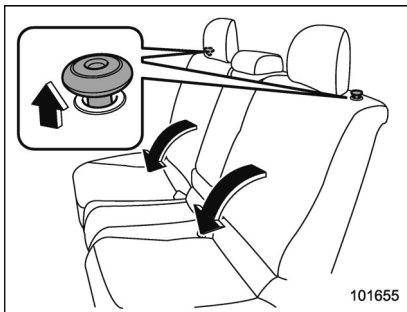

101655

Unlock the seatback by pulling the lock release knob and then fold the seatback down.

▼ Return the rear seatback

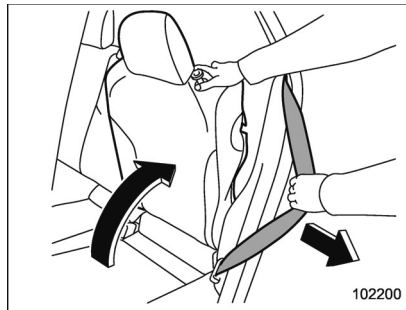

102200

⚠ WARNING

When returning the seatback to its original position, observe the following precaution.

Failure to observe the precaution may damage the seatbelt, impairing its effectiveness, and possibly result in a serious injury.

- **When returning the seatback to its original position, pull the seatbelt out towards the vehicle exterior so that it will not be caught between the seatback and the trim.**

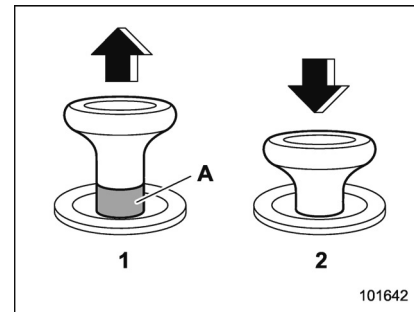

101642

Lock release knob

- 1) Unlocked
 - 2) Locked
- A) Unlocking marker in red

To return the seatback to its original position, raise the seatback until it locks into place and make sure that the unlocking marker on the lock release knob is no longer visible.

⚠ WARNING

When you return the seatback to its original position, check that the unlocking marker on the lock release knob is not visible. Also, shake the seatback slightly to confirm that it is securely fixed in place. If the seatback is not securely fixed in place, the seatback may suddenly

fold down in the event of sudden braking, or objects may move out from the cargo area or trunk, which could cause serious injury or death.

■ Head restraint

▼ Front seats

Both the driver's seat and the front passenger's seat are equipped with head restraints. Both head restraints are adjustable in the following ways.

▽ Height adjustment

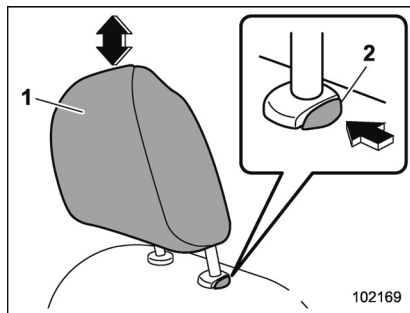

- 1) Head restraint
- 2) Release button

To raise:

Pull the head restraint up.

To lower:

Push the head restraint down while pressing the release button on the top of the seatback.

To remove:

While pressing the release button, pull out the head restraint.

To install:

Install the head restraint into the holes that are located on the top of the seatback until the head restraint locks. Press and hold the release button to lower the head restraint.

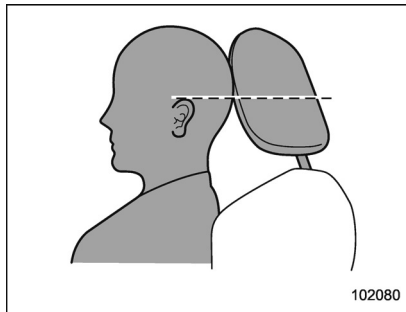

Each head restraint should be adjusted so that the center of the head restraint is closest to the top of the occupant's ears.

NOTE

When the head restraint cannot be pulled out or installed due to insufficient clearance between the head restraint and the roof, tilt the seat and then perform the installation and removal tasks.

▽ Angle adjustment

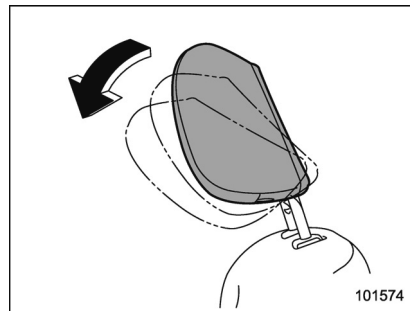

The angle of the head restraint can be adjusted in several steps. While maintaining a suitable driving posture, adjust the head restraint to a position where the back of your head is as close to the head restraint as possible.

To tilt:

Tilt the head restraint by hand to the preferred position. A click will be audible when the head restraint is locked.

To return:

Tilt the head restraint once as far forward as it can go. The head restraint will automatically return to the fully upright position. Then, adjust the head restraint again to the preferred angle.

▼ Rear seats

Both the rear window side seats and the rear center seat are equipped with head restraints.

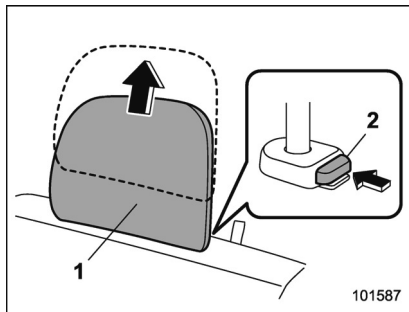
▼ Rear windows side seating position

- 1) Head restraint
- 2) Release button

To remove:

While pressing the release button, pull out the head restraint.

To install:

Install the head restraint into the holes that are located on the top of the seatback until the head restraint locks. Press and hold the release button to lower the head restraint.

After installing the head restraint, make sure it is securely locked.

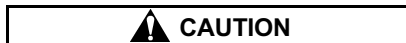
▼ Rear center seating position

The head restraint is not intended to be used at the retracted position. Before sitting on the seat, raise the head restraint to the extended position.

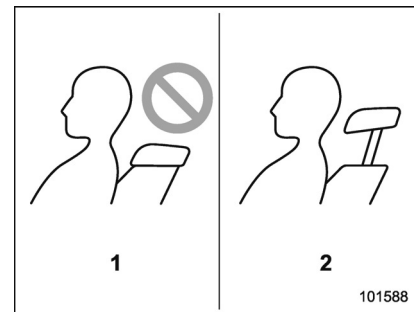

- 1) Incorrect (retracted position)
- 2) Correct (extended position)

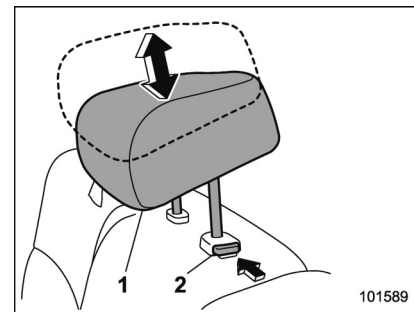

- 1) Head restraint
- 2) Release button

To raise:

Pull the head restraint up.

To lower:

Push the head restraint down while pressing the release button on the top of the seatback.

To remove:

While pressing the release button, pull out the head restraint.

To install:

Install the head restraint into the holes that are located on the top of the seatback until the head restraint locks. Press and hold the release button to lower the head restraint.

When the rear-center seating position is occupied, raise the head restraint to the extended position. When the rear center seating position is not occupied, lower the head restraint to improve rearward visibility.

Seat heater (if equipped)

The seat heater is equipped in the front seats.

The seat heater operates when the ignition switch is either in the "ACC" or "ON" position.

■ Safety precautions



CAUTION

- **People with delicate skin may suffer slight burns even at low temperatures if they use the seat heater for a long period of time. When using the heater, always be sure to warn the persons concerned.**
- **Do not put anything on the seat which insulates against heat, such as a blanket, cushion, or similar items. This may cause the seat heater to overheat.**
- **When the seat is warmed enough or before you leave the vehicle, be sure to turn off the seat heater.**

NOTE

Use of the seat heater for a long period of time while the engine is not running can cause battery discharge.

■ Operation

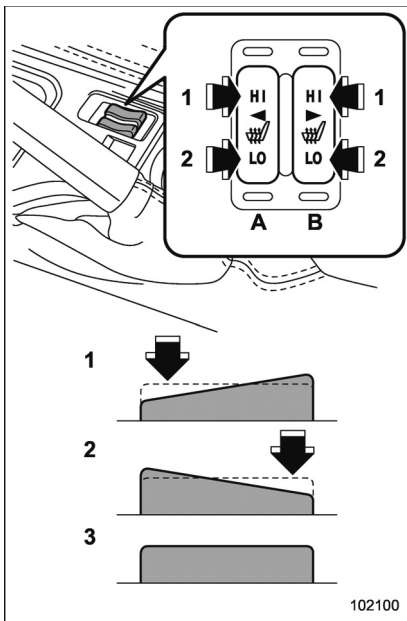

- 1) **HI** – Rapid heating
- 2) **LO** – Normal heating
- 3) Off
- A) Left-hand side
- B) Right-hand side

To turn on the seat heater, push the “LO” or “HI” position on the switch, as desired, depending on the temperature.

Selecting the “HI” position will cause the seat to heat up quicker.

To turn off the seat heater, lightly press the opposite side of the current position.

The indicator located on the switch illuminates when the seat heater is in operation.

Seatbelts

■ Seatbelt safety tips

WARNING

- All persons in the vehicle should fasten their seatbelts **BEFORE** the vehicle starts to move. Otherwise, the possibility of serious injury becomes greater in the event of a sudden stop or accident.
- All belts should fit snugly in order to provide full restraint. Loose fitting belts are not as effective in preventing or reducing injury.
- Each seatbelt is designed to support only one person. Never use a single belt for two or more persons – even children. Otherwise, in an accident, serious injury or death could result.
- Replace all seatbelt assemblies including retractors and attaching hardware worn by occupants of a vehicle that has been in a serious accident. The entire assembly should be replaced even if damage is not obvious.
- Never use a belt that is twisted or

reversed. In an accident, this can increase the risk or severity of injury.

- Keep the lap belt as low as possible on your hips. In a collision, this spreads the force of the lap belt over stronger hip bones instead of across the weaker abdomen.
- Seatbelts provide maximum restraint when the occupant sits well back and upright in the seat. To reduce the risk of sliding under the seatbelt in a collision, the front seatbacks should be always used in the upright position while the vehicle is running. If the front seatbacks are not used in the upright position in a collision, the risk of sliding under the lap belt and of the lap belt sliding up over the abdomen will increase, and both can result in serious internal injury or death.
- Do not put cushions or any other materials between occupants and seatbacks or seat cushions. If you do so, the risk of sliding under the lap belt and of the lap belt sliding up over the abdomen will increase, and both can result in serious internal injury or

death.

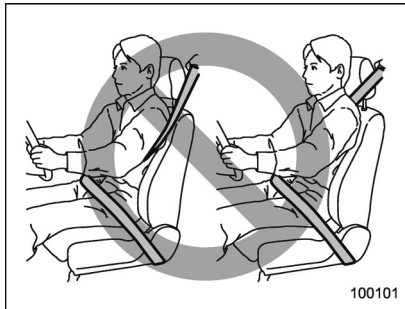

WARNING

Never place the shoulder belt under the arm or behind the back. If an accident occurs, this can increase the risk or severity of injury.

CAUTION

Metallic parts of the seatbelt can become very hot in a vehicle that has been closed up in sunny weather; they could burn an occupant. Do not touch such hot parts until they cool.

Your vehicle is equipped with a crash sensing and diagnostic module, which will record the use of the seatbelt by the front passenger when any of the SRS frontal, side and curtain airbags deploy.

▼ Infants or small children

Use a child restraint system that is suitable for your vehicle. Refer to "Child restraint systems" 1-25.

▼ Children

WARNING

Place children in the rear seat properly restrained at all times. The SRS airbag deploys with considerable speed and force and can injure or even kill children, especially if they are not restrained or improperly restrained. Because children are lighter and weaker than adults, their risk of being injured from deployment is greater. For that reason, we strongly recommend that ALL children (including those in child seats and those that have outgrown child restraint devices) sit in the REAR seat properly restrained at all times in a child restraint device or in a seatbelt, whichever is appropriate for the child's height and weight.

Secure ALL types of child restraint devices (including forward facing child seats) in the REAR seats at all times.

NEVER INSTALL A FORWARD OR REARWARD FACING CHILD SEAT IN THE FRONT SEAT. DOING SO RISKS SERIOUS INJURY OR DEATH TO THE CHILD BY PLACING THE CHILD'S HEAD TOO CLOSE TO THE SRS AIRBAG.

According to accident statistics, children are safer when properly restrained in the rear seating positions than in the front seating positions. For instructions and precautions concerning the child restraint system, refer to "Child restraint systems" 1-25.

If a child is too big for a child restraint system, the child should sit in the rear seat and be restrained using the seatbelts. According to accident statistics, children are safer when properly restrained in the rear seating positions than in the front seating positions. Never allow a child to stand up or kneel on the seat.

If the shoulder portion of the belt crosses the face or neck, move the child closer to the belt buckle to help provide a good

shoulder belt fit. Care must be taken to securely place the lap belt as low as possible on the hips and not on the child's waist. If the shoulder portion of the belt cannot be properly positioned, a child restraint system should be used. Never place the shoulder belt under the child's arm or behind the child's back.

▼ Expectant mothers

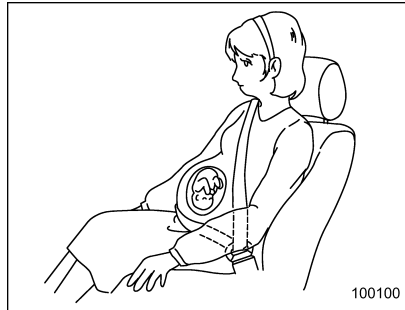

Expectant mothers also need to use the seatbelts. They should consult their doctor for specific recommendations. The lap belt should be worn securely and as low as possible over the hips, not over the waist.

■ Emergency Locking Retractor (ELR)

The driver's seatbelt has an Emergency Locking Retractor (ELR).

The emergency locking retractor allows normal body movement but the retractor locks automatically during a sudden stop, impact or if you pull the belt very quickly out of the retractor.

■ Automatic Locking Retractor/ Emergency Locking Retractor (ALR/ELR)

Each passenger's seatbelt has an Automatic Locking Retractor/Emergency Locking Retractor (ALR/ELR). The Automatic Locking Retractor/Emergency Locking Retractor normally functions as an Emergency Locking Retractor (ELR). The ALR/ELR has an additional locking mode "Automatic Locking Retractor (ALR) mode" intended to secure a child restraint system. When the seatbelt is once drawn out completely and is then retracted even slightly, the retractor locks the seatbelt in that position and the seatbelt cannot be extended. As the belt is rewinding, clicks will be heard which indicate the retractor functions as an ALR. When the seatbelt is retracted fully, the ALR mode is released.

When securing a child restraint system on

the rear seats by the use of the seatbelt, the seatbelt must be changed over to the Automatic Locking Retractor (ALR) mode.

When the child restraint system is removed, make sure that the seatbelt retracts fully and the retractor returned to the Emergency Locking Retractor (ELR) mode.

For instructions on how to convert the retractor to the ALR mode and restore it to the ELR mode, refer to "Installing child restraint systems with ALR/ELR seatbelt" 1-28.

■ Seatbelt warning light and chime



Refer to "Seatbelt warning light and chime" 3-14.

■ Fastening the seatbelt

▼ Front seatbelts

1. Adjust the seat position according to the following procedure.

Driver's seat: Adjust the seatback to the upright position. Move the seat as far from the steering wheel as practical while still maintaining full vehicle control.

Front passenger's seat: Adjust the seatback to the upright position. Move the seat as far back as possible.

2. Sit well back in the seat.
3. Pick up the tongue plate and pull the belt out slowly. Do not let it get twisted.

- If the belt stops before reaching the buckle, return the belt slightly and pull it out more slowly.
- If the belt still cannot be unlocked, let the belt retract slightly after giving it a strong pull, then pull it out slowly again.

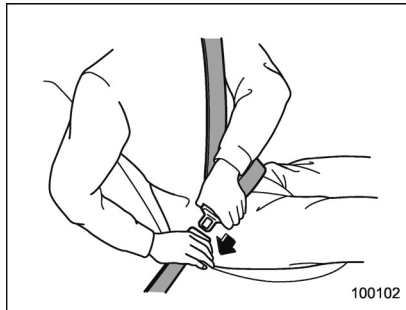

4. Insert the tongue plate into the buckle until you hear a click.

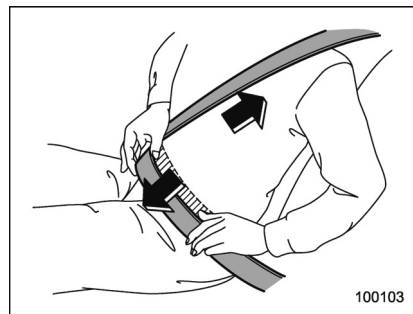

5. To make the lap part tight, pull up on the shoulder belt.
6. Place the lap belt as low as possible on your hips, not on your waist.

▽ Adjusting the front seat shoulder belt anchor height

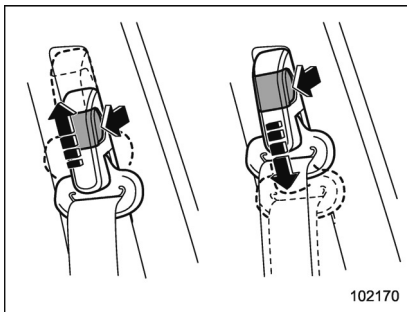

The shoulder belt anchor height should be adjusted to the position best suited for the driver/front passenger. Always adjust the anchor height so that the shoulder belt passes over the middle of the shoulder without touching the neck.

To raise:

Pull the release knob and slide the anchor up.

To lower:

Pull the release knob and slide the anchor down.

Pull down on the anchor to make sure that it is locked in place.

⚠ WARNING

When wearing the seatbelts, make sure the shoulder portion of the webbing does not pass over your neck. If it does, adjust the seatbelt anchor to a lower position. Placing the shoulder belt over the neck may result in neck injury during sudden braking or in a collision.

▽ Unfastening the seatbelt

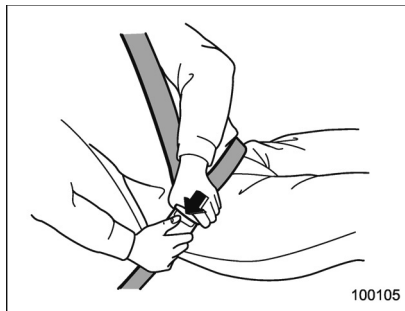

1. Push the button on the buckle.
2. Have the seatbelt retracted slowly to avoid the seatbelt being tangled or twisted.

Before closing the door, make sure that the belts are retracted properly to avoid

catching the belt webbing in the door.

▼ Rear seatbelts (except rear center seatbelt on 5-door models)

1. Sit well back in the seat.
2. Pick up the tongue plate and pull the belt out slowly. Do not let it get twisted.
 - If the belt stops before reaching the buckle, return the belt slightly and pull it out more slowly.
 - If the belt still cannot be unlocked, let the belt retract slightly after giving it a strong pull, then pull it out slowly again.

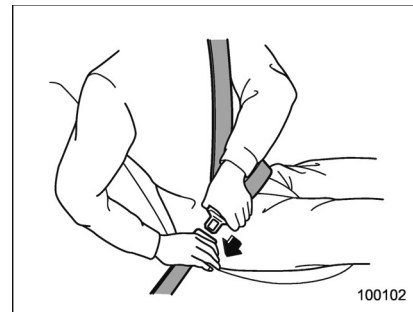

3. Insert the tongue plate into the buckle until you hear a click.

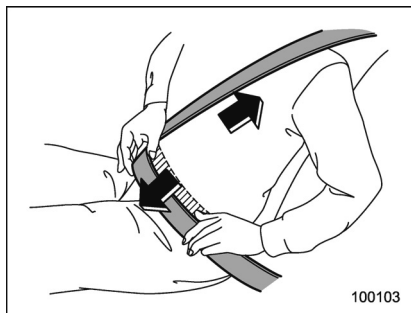

4. To make the lap part tight, pull up on the shoulder belt.
5. Place the lap belt as low as possible on your hips, not on your waist.

▼ **Unfastening the seatbelt**

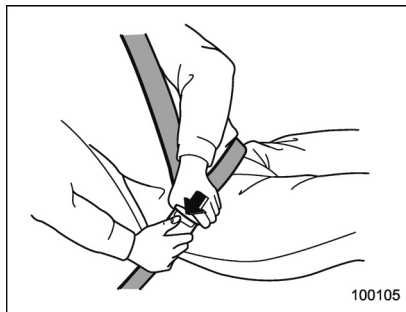

1. Push the button on the buckle.
2. Have the seatbelt retracted slowly to avoid the seatbelt being tangled or twisted.

Before closing the door, make sure that the belts are retracted properly to avoid catching the belt webbing in the door.

▼ **Rear center seatbelt on 5-door models**

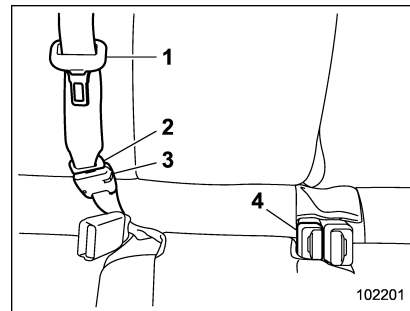

- 1) Center seatbelt tongue plate
- 2) Connector (tongue)
- 3) Connector (buckle)
- 4) Center seatbelt buckle

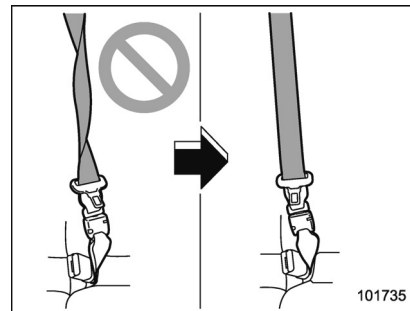

WARNING

Fastening the seatbelt with the webbing twisted can increase the risk or severity of injury in an accident. When fastening the belt after it is pulled out from the retractor, especially when inserting the connector's tongue plate into the mating buckle (on right-hand side), always check that the webbing is not twisted.



100109

WARNING

- Be sure to fasten both tongue plates to the respective buckles. If the seatbelt is used only as a shoulder belt (with the connector's tongue plate not fastened to the connector's buckle on the right-hand side), it cannot properly restrain the wearer in position in an accident, possibly resulting in serious injury or death.
- The head restraint is not intended to be used at the lowest position. Before sitting on the seat, raise the head restraint to the extended position. Otherwise, in an accident, serious injury or death could result.

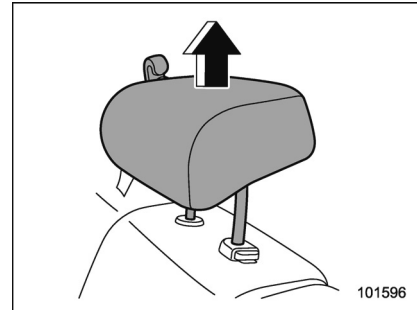

101596

1. Raise the head restraint to the extended position. Do not remove the head restraint.

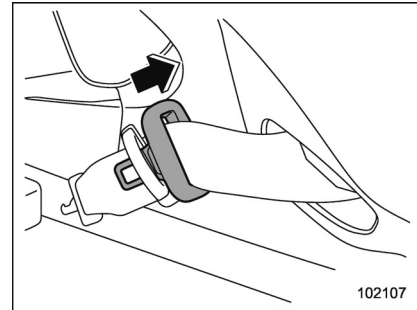

102107

2. Remove the tongue plate from the belt holder on the right side of the cargo area and pull out the seatbelt slowly.

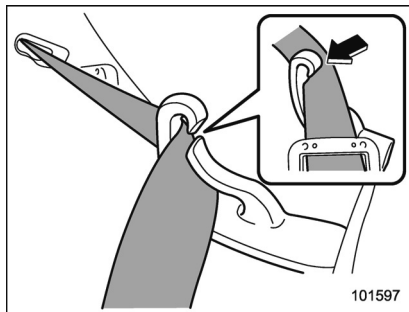

3. After drawing out the seatbelt, pass it through the belt guide as follows: First insert one edge of the belt into the open gap in the belt guide; then slide the rest of the belt in, so that the whole belt fits inside.

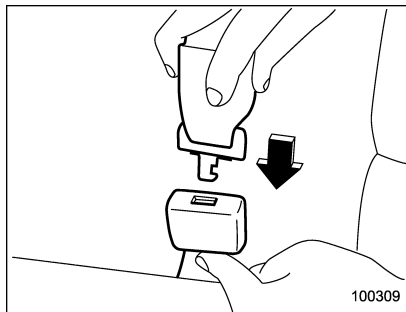

4. After confirming that the webbing is not twisted, insert the connector (tongue) attached at the webbing end into the buckle on the right-hand side until a click is heard.

- If the belt stops before reaching the buckle, return the belt slightly and pull it out more slowly.
- If the belt still cannot be unlocked, let the belt retract slightly after giving it a strong pull, then pull it out slowly again.

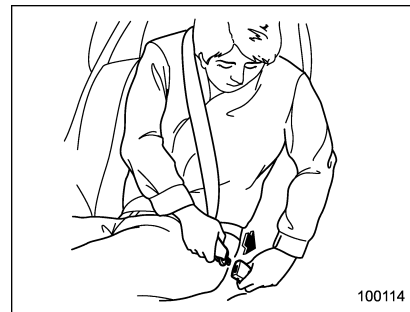

5. Insert the center seatbelt tongue plate into the center seatbelt buckle until it clicks.

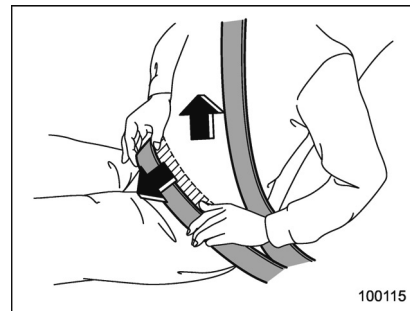

6. To make the lap part tight, pull up on the shoulder belt.
7. Place the lap belt as low as possible

on your hips, not on your waist.

▽ Unfastening the seatbelt

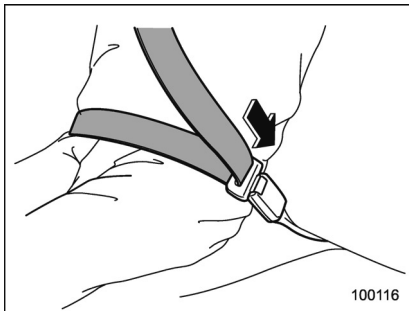

1. Push the release button of the center seatbelt buckle (on the left-hand side) to unfasten the seatbelt.

NOTE

When the seatback is folded down for greater cargo area, it is necessary to disconnect the connector.

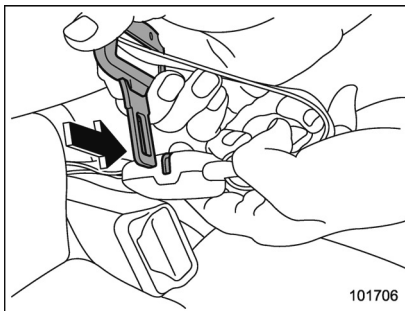

2. Insert a tongue plate or other hard pointed object into the slot in the connector (buckle) on the right-hand side and push it in. The connector (tongue) plate will then disconnect from the buckle.

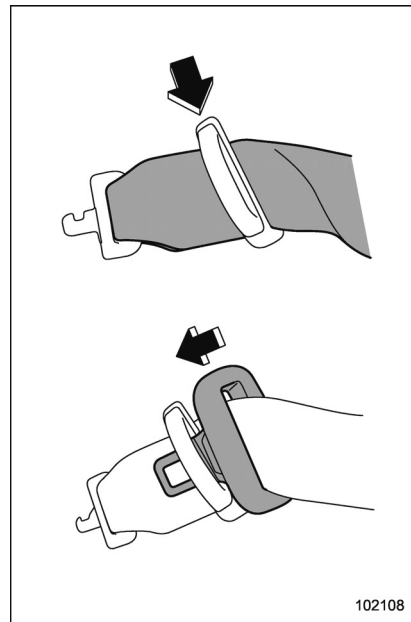

3. Allow the retractor to roll up the belt. You should hold the webbing end and guide it back into the retractor while it is rolling up. Insert the connector (tongue) into the belt holder.

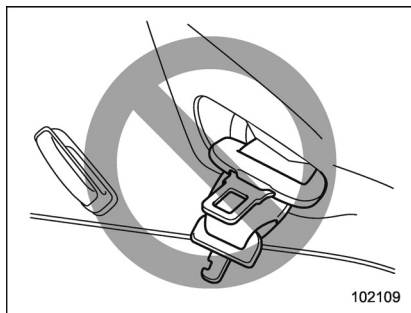

CAUTION

- Do not allow the retractor to roll up the seatbelt too quickly. Otherwise, the metal tongue plates may hit against the trim, resulting in damaged trim.
- Have the seatbelt fully rolled up so that the tongue plates are neatly stored. A hanging tongue plate can swing and hit against the trim during driving, causing damage to the trim.

Seatbelt maintenance

To clean the seatbelts, use a mild soap and lukewarm water. Never bleach or dye the belts because this could seriously affect their strength.

Inspect the seatbelts and attachments including the webbing and all hardware periodically for cracks, cuts, gashes, tears, damage, loose bolts or worn areas. Replace the seatbelts even if only minor damage is found.

CAUTION

- Keep the belts free of polishes, oils, chemicals and particularly battery acid.
- Never attempt to make modifications or changes that will prevent the seatbelt from operating properly.

Seatbelt pretensioners

The following seatbelts have a seatbelt pretensioner.

- Driver's seatbelt
- Front passenger's seatbelt

The seatbelt pretensioners are designed to be activated in the event of an accident involving a moderate to severe frontal and side collision and rollover accident.

WARNING

- To obtain maximum protection, the occupants should sit in an upright position with their seatbelts properly fastened. Refer to "Seatbelts" 1-11.
- Do not modify, remove or strike the seatbelt retractor assemblies equipped with seatbelt pretensioners or surrounding area. This could result in accidental activation of the seatbelt pretensioners or could make the system inoperative, possibly resulting in serious injury. Seatbelt pretensioners have no user-serviceable parts. For required servicing of seatbelt retractors equipped with seatbelt pretensioners, consult

your SUBARU dealer.

- When discarding seatbelt retractor assemblies equipped with seatbelt pretensioners or scrapping the entire vehicle due to collision damage or for other reasons, consult your SUBARU dealer.

NOTE

- Seatbelt pretensioners are not designed to activate in minor impacts or in rear impacts.
- Pretensioners are designed to function on a one-time-only basis. In the event that a pretensioner is activated, both the driver's and front passenger's seatbelt retractor assemblies should be replaced only by an authorized SUBARU dealer. When replacing seatbelt retractor assemblies, use only genuine SUBARU parts.
- If a seatbelt that has a seatbelt pretensioner does not retract or cannot be pulled out due to a malfunction or activation of the pretensioner, contact your SUBARU dealer as soon as possible.
- If the seatbelt retractor assembly or surrounding area has been damaged, contact your SUBARU dealer as soon

as possible.

- When you sell your vehicle, we urge you to explain to the buyer that it has seatbelt pretensioners by alerting the buyer to the contents of this section.

■ Seatbelt with shoulder belt pretensioner

NOTE

This section is applicable to the following components.

- Driver's seatbelt

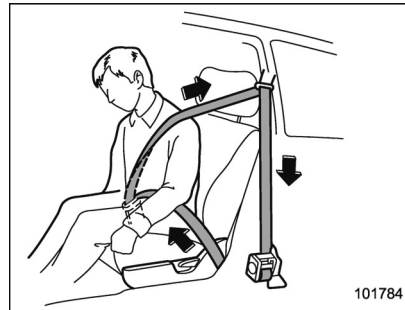

Front seatbelt pretensioner

The pretensioner sensor also serves as follows.

- SRS frontal airbag sensor
- Side impact sensor

- Front door impact sensor
- Rollover sensor

If the sensor detects a certain predetermined amount of force during frontal or side collisions or rollover accidents, any seatbelt that has a seatbelt pretensioner is quickly drawn back in by the retractor to take up the slack so that the belt more effectively restrains the seat occupant.

The driver's seatbelt pretensioner includes a tension reducing device which limits the peak forces exerted by the seatbelt on the occupant in the event of a collision.

When a seatbelt pretensioner is activated, an operating noise will be heard and a small amount of smoke will be released. These occurrences are normal and not harmful. This smoke does not indicate a fire in the vehicle.

Once the seatbelt pretensioner has been activated, the seatbelt retractor remains locked. Consequently, the seatbelt can not be pulled out and retracted and therefore must be replaced.

▼ In cases of rollover accident, frontal collisions or side collisions, the following components will operate simultaneously

For details, refer to “In cases of rollover accident, frontal collisions or side collisions, the following components will operate simultaneously” 1-23.

■ Seatbelt with shoulder belt and lap belt pretensioners

NOTE

This section is applicable to the front passenger's side seatbelt.

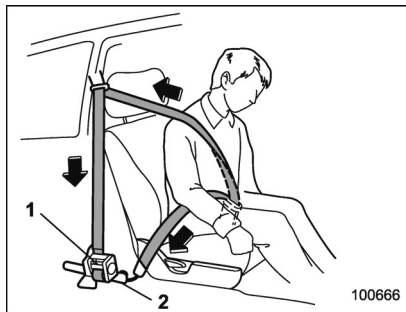

- 1) Seatbelt retractor assembly (shoulder belt pretensioner and adaptive force limiter)
- 2) Lap belt pretensioner

On the front passenger's side, the shoulder belt pretensioner is supplemented by a lap belt pretensioner, which is located at the base of the center pillar. Like the shoulder belt pretensioner, the lap belt pretensioner instantaneously pulls in the belt to eliminate slack if a certain level of frontal collision force is detected. As a result, the seatbelt restrains the front seat

occupant more effectively.

The front passenger's seatbelt pretensioner includes a tension reducing device which limits the peak forces exerted by the seatbelt on the occupant in the event of a collision.

The adaptive force limiter will select a reducing load to the suit body size of occupant as detected by the occupant detection sensor.

When a seatbelt pretensioner is activated, an operating noise will be heard and a small amount of smoke will be released. These occurrences are normal and not harmful. This smoke does not indicate a fire in the vehicle.

Once the seatbelt pretensioner has been activated, the seatbelt pretensioner remains locked. Consequently, the seatbelt cannot be pulled out and retracted and therefore must be replaced.

▼ In cases of rollover accident, frontal collisions or side collisions, the following components will operate simultaneously

	Driver's side seatbelt pretensioner	Front passenger's side shoulder belt pretensioner	Front passenger's side lap belt pretensioner	SRS frontal airbag for driver	SRS frontal airbag for front passenger	SRS curtain airbags	SRS side airbags
Rollover accidents	○	○	–	–	–	○ both sides	–
Frontal collisions	○	○	○	○	○ ^{*1}	–	–
	Offset frontal collisions	○	○	○	○	○ ^{*1}	○ both sides
Side collisions	○ ^{*3}	○ ^{*4}	–	–	–	○ impacted side	○ ^{*2} impacted side
Rear impact	–	–	–	–	–	–	–
Minor impact	–	–	–	–	–	–	–

○: Activated
–: Not activated

*1: This does not operate if the occupant detection system deactivates airbag operation.

*2: When both the satellite safing sensor and any of the center pillar impact sensors/front door impact sensors sense an impact force.

*3: When both the satellite safing sensor and the driver's side front door impact sensor sense an impact force.

However, when a center pillar impact sensor detects a signal faster than the front door impact sensor, or both sensors detect signals simultaneously, the seatbelt pretensioner does not activate.

*4: When both the satellite safing sensor and the front passenger's side front door impact sensor sense an impact force.

However, when a center pillar impact sensor detects a signal faster than the front door impact sensor, or both sensors detect signals simultaneously, the seatbelt pretensioner does not activate.

■ System monitors

A diagnostic system continually monitors the readiness of the seatbelt pretensioner while the vehicle is being driven. The seatbelt pretensioners share the control module with the SRS airbag system. Therefore, if any malfunction occurs in a seatbelt pretensioner, the SRS airbag system warning light will illuminate. For details, refer to "SRS airbag system monitors" 1-66.

■ System servicing

WARNING

- When discarding a seatbelt retractor assembly or scrapping the entire vehicle damaged by a collision, consult your SUBARU dealer.
- Tampering with or disconnecting the system's wiring could result in accidental activation of the seatbelt pretensioner and/or SRS airbag or could make the system inoperative, which may result in serious injury. Do not use electrical test equipment on any circuit related to the seatbelt pretensioner and SRS airbag systems. For required servicing

of the seatbelt pretensioner, consult your nearest SUBARU dealer.

CAUTION

The sensors and SRS airbag control modules are located in the following locations.

- Front sub sensors: on both the right and left side at the front of the vehicle
- Front door impact sensors: on both front doors
- Satellite safing sensor: under the rear center seat
- SRS airbag control module (including the impact sensors): under the center of the instrument panel

If you need service or repair in those areas or near the front seatbelt retractors, have the work performed by your authorized SUBARU dealer.

NOTE

If the front or side part of the vehicle is damaged in an accident to the extent that the seatbelt pretensioner does not

operate, contact your SUBARU dealer as soon as possible.

■ Precautions against vehicle modification

Always consult your SUBARU dealer if you want to install any accessory parts to your vehicle.

CAUTION

Do not perform any of the following modifications. Such modifications can interfere with proper operation of the seatbelt pretensioners.

- Attachment of any equipment (bush bar, winches, snow plow, skid plate, etc.) other than genuine SUBARU accessory parts to the front end.
- Modification of the suspension system or front end structure.
- Installation of a tire of different size and construction from the tires specified on the vehicle placard attached to the driver's door pillar or specified for individual vehicle models in this Owner's Manual.

Child restraint systems



Infants and small children should always be placed in an infant or child restraint system in the rear seat while riding in the vehicle.

You should use an infant or child restraint system that meets Federal Motor Vehicle Safety Standards or Canada Motor Vehicle Safety Standards, is compatible with your vehicle and is appropriate for the child's age and size.

All child restraint systems are designed to be secured in vehicle seats by lap belts or the lap belt portion of a lap/shoulder belt (except those described in "Installation of child restraint systems by use of lower and tether anchorages (LATCH)" ¶ 1-33).

Children could be endangered in an accident if their child restraints are not properly secured in the vehicle. When installing the child restraint system, carefully follow the manufacturer's instructions.

According to accident statistics, children are safer when properly restrained in the rear seating positions than in the front seating positions.

All U.S. states and Canadian provinces require that infants and small children be restrained in an approved child restraint system at all times while the vehicle is moving.



WARNING

Never let a passenger hold a child on his or her lap or in his or her

arms while the vehicle is moving. The passenger cannot protect the child from injury in a collision, because the child will be caught between the passenger and objects inside the vehicle.

Additionally, holding a child in your lap or arms in the front seat exposes that child to another serious danger. Since the SRS airbag deploys with considerable speed and force, the child could be injured or even killed.

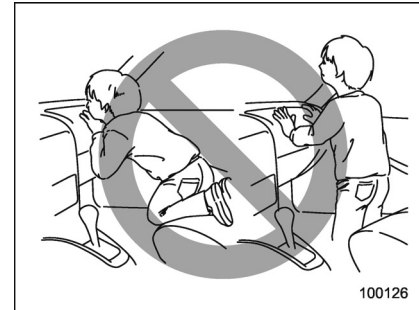

WARNING

Children should be properly restrained at all times. Never allow a child to stand up, or to kneel on any

seat. Unrestrained children will be thrown forward during sudden stop or in an accident and can be injured seriously.

Additionally, children standing up or kneeling on or in front of the front seat are exposed another serious danger. Since the SRS airbag deploys with considerable speed and force, the child could be injured or even killed.

■ Safety tips for installing child restraint systems

▲ WARNING

- Child restraint systems and seatbelts can become hot in a vehicle that has been closed up in sunny weather; they could burn a small child. Check the child restraint system before you place a child in it.

- Do not leave an unsecured child restraint system in your vehicle. Unsecured child restraint systems can be thrown around inside of the vehicle in a sudden stop, turn or accident; they can strike and injure vehicle occupants as well as result in serious injuries or death to the child.

▲ CAUTION

When you install a child restraint system, follow the manufacturer's instructions supplied with it. After installing the child restraint system, check to ensure that it is held tight and secure. If it is not held tight and secure, the danger of your child suffering personal injury in the event of an accident may be increased.

■ Where to place a child restraint system

The following are SUBARU's recommendations on where to place a child restraint system in your vehicle.

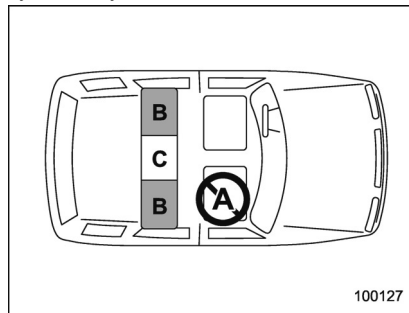

A: Front passenger's seat

You should not install a child restraint system (including a booster seat) due to the hazard to children posed by the passenger's airbag.

B: Rear seat, window-side seating positions

Recommended positions for all types of child restraint systems.

In these positions, the following equipment is provided for installing a child restraint system.

- Automatic Locking Retractor/Emer-

gency Locking Retractor (ALR/ELR) seatbelts

- Lower anchorages (bars)
- Upper anchorages (tether anchorages)

Some types of child restraints might not be able to be secured firmly due to projection of the seat cushion.

In this seating position, you should use only a child restraint system that has a bottom base that fits snugly against the contours of the seat cushion and can be securely retained using the seatbelt.

C: Rear seat, center seating position

The ALR/ELR seatbelt and an upper anchorage (tether anchorage) are provided in this position.

Some types of child restraints might not be able to be secured firmly due to projection of the seat cushion.

In this seating position, you should use only a child restraint system that has a bottom base that fits snugly against the contours of the seat cushion and can be securely retained using the seatbelt.

When you install a child restraint system in the rear seat's center seating position, raise the center head restraint.

Lower anchorages (bars) for window-side seating positions may be used for a seat in the center seating position if a child

restraint system manufacturer's instructions permit and specify using anchors as far apart as those in this vehicle.

If a child restraint system is not correctly fixed in place (for example, if a child restraint system can be moved more than 1 inch (2.5 cm) from side to side), you should install the child restraint system in a rear seat, window-side seating position.

⚠ WARNING

- **Even with advanced airbags, children can be seriously injured by the airbag. Place children in the rear seat properly restrained at all times. The SRS airbag deploys with considerable speed and force and can injure or even kill children, especially if they are not restrained or improperly restrained. Because children are lighter and weaker than adults, their risk of being injured from deployment is greater.**

For that reason, be sure to secure ALL types of child restraint devices (including forward facing child seats) in the REAR seats at all times. You should choose a restraint device which is appropriate for the child's age, height

and weight. According to accident statistics, children are safer when properly restrained in the rear seating positions than in the front seating positions.

- **Do not use lower anchorages (bars) for a seat in the center seating position unless a child restraint system manufacturer's instructions permit and specify using anchors spaced as far apart as those in this vehicle.**
- **Do not connect two or more lower hooks onto the same anchorage (bar).**

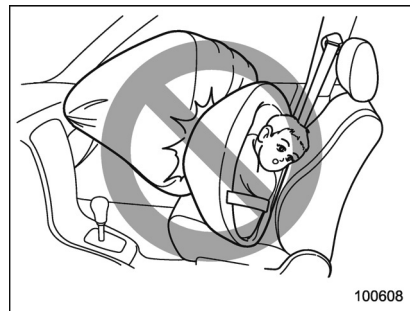

100608

▲ WARNING

SINCE YOUR VEHICLE IS EQUIPPED WITH A PASSENGER'S SRS AIRBAG, NEVER INSTALL A FORWARD OR REARWARD FACING CHILD SAFETY SEAT IN THE FRONT PASSENGER'S SEAT. DOING SO RISKS SERIOUS INJURY OR DEATH TO THE CHILD BY PLACING THE CHILD'S HEAD TOO CLOSE TO THE SRS AIRBAG.

■ Choosing a child restraint system

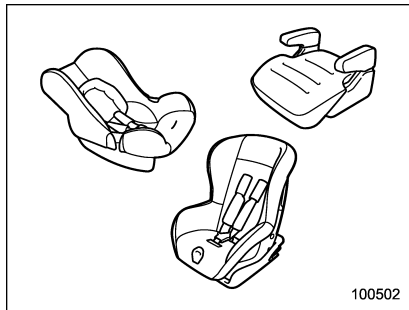

Choose a child restraint system that is appropriate for the child's age and size (weight and height) in order to provide the

child with proper protection. The child restraint system should meet all applicable requirements of Federal Motor Vehicle Safety Standards for the United States or of Canada Motor Vehicle Safety Standards for Canada. It can be identified by looking for the label on the child restraint system or the manufacturer's statement of compliance in the document attached to the system.

Also it is important for you to make sure that the child restraint system is compatible with the vehicle in which it will be used.

■ Installing child restraint systems with ALR/ELR seatbelt

▲ CAUTION

When installing a child restraint system in the rear center seating position, set both seatbacks to the original position. Otherwise, the child restraint system cannot be securely restrained, which may result in death or serious injuries in the event of sudden stop, sudden steering maneuver or an accident.

▼ Installing a rearward facing child restraint

▲ WARNING

NEVER INSTALL A FORWARD OR REARWARD FACING CHILD SEAT IN THE FRONT PASSENGER'S SEAT. DOING SO RISKS SERIOUS INJURY OR DEATH TO THE CHILD BY PLACING THE CHILD'S HEAD TOO CLOSE TO THE SRS AIRBAG.

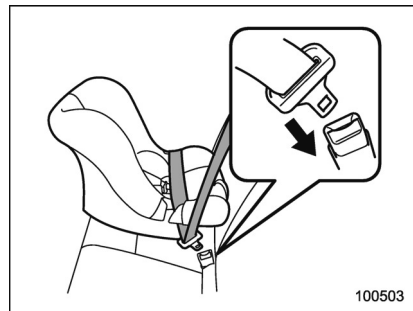

1. Place the child restraint system in the rear seating position.
2. Run the lap and shoulder belt through or around the child restraint system following the instructions provided by its manufacturer.

3. Insert the tongue plate into the buckle until you hear a click.

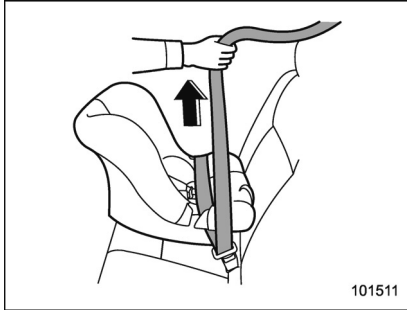

4. Take up the slack in the lap belt.
5. If using the seatbelt in the ALR mode is recommended by the manufacturer's instructions supplied with the child restraint system, perform the following procedure.
- (1) Pull out the seatbelt fully from the retractor to change the retractor over from the Emergency Locking Retractor (ELR) to the Automatic Locking Retractor (ALR) mode.
- (2) Allow the belt to rewind into the retractor. As the belt is rewinding, clicks will be heard which indicate the retractor functions as ALR.

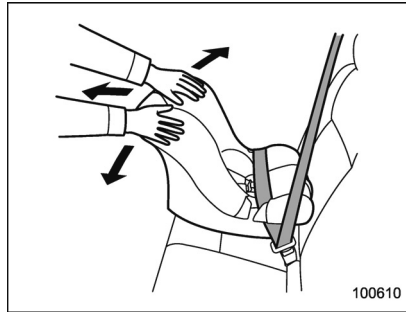

6. Push and pull the child restraint system forward and from side to side to check if it is firmly secured. Sometimes a child restraint can be more firmly secured by pushing it down into the seat cushion and then tightening the seatbelt.
7. If the seatbelt has been set to the ALR mode in step 5, pull at the shoulder portion of the belt to confirm that it cannot be pulled out (ALR properly functioning).

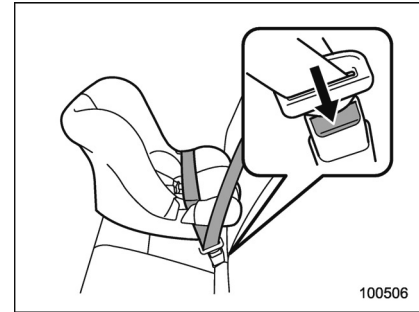

8. To remove the child restraint system, press the release button on the seatbelt buckle and allow the belt to retract completely. The belt will return to the ELR mode.

NOTE

When the child restraint system is no longer in use, remove it and restore the ELR function of the retractor. That function is restored by allowing the seatbelt to retract fully.

▼ **Installing forward facing child restraint**

WARNING

Before installing a child restraint system, be sure to confirm that the seatback is securely locked into place. Otherwise, in an accident, serious injury or death could result.

1. Shake the seatback slightly to confirm that it is securely locked into place.
 - It is possible to check whether the seatback is locked visually. If the seatback is locked into place, the red colored unlocking marker which is attached to the bottom of the lock release knob is invisible. For details, refer to “Folding down the rear seatback” 1-6.
2. Prepare the rear seat head restraint where a child restraint system is intended to be installed in the following way.
 - When a child restraint system is installed on the **window-side seating position** or the **rear center seating position of a sedan**, remove the rear seat head restraint. For details, refer to “Rear seats” 1-9.
Store the head restraint in the trunk (sedan) or cargo area (5-door models).

Avoid placing the head restraint in the passenger compartment to prevent it from being thrown around in the passenger compartment in a sudden stop or a sharp turn.

- When a child restraint system is installed on the **rear center seating position of a 5-door model**, raise the rear seat head restraint to the extended position. Do not remove the head restraint. For details, refer to “Rear seats” 1-9.
3. Place the child restraint system in the rear seating position.

WARNING

When you intend to install a child restraint system on the rear center seating position, if the child restraint system does not fit snugly against the contours of the rear center seat cushion, install the child restraint system on the window-side seating position to be safe. For details, refer to “Where to place a child restraint system” 1-26.

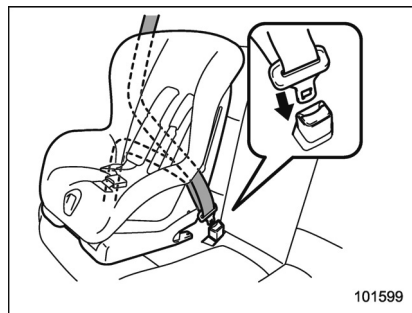

4. Run the lap and shoulder belt through or around the child restraint system following the instructions provided by its manufacturer.
 - When a child restraint system is installed on the rear center seating position of a 5-door model, pass the rear center seatbelt through the belt guide properly. For details, refer to “Rear center seatbelt on 5-door models” 1-16.
5. Insert the tongue plate into the buckle until you hear a click.

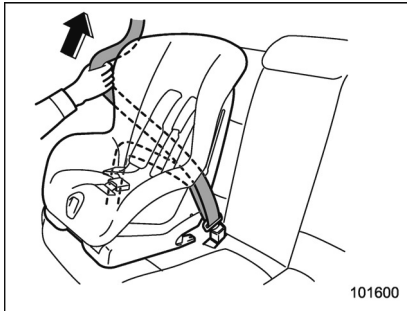

6. Take up the slack in the lap belt.
7. Pull out the seatbelt fully from the retractor to change the retractor over from the Emergency Locking Retractor (ELR) to the Automatic Locking Retractor (ALR) function. Then, allow the belt to rewind into the retractor. As the belt is rewinding, clicks will be heard which indicate the retractor functions as ALR.

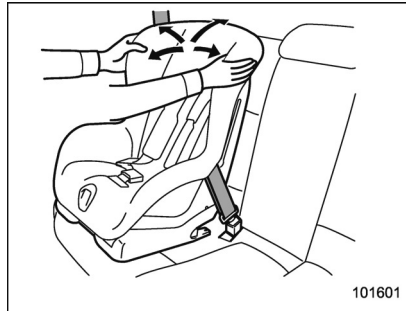

8. Before having a child sit in the child restraint system, try to move it back and forth and right and left to check if it is firmly secured. Sometimes a child restraint system can be more firmly secured by pushing it down into the seat cushion and then tightening the seatbelt.
9. Pull at the shoulder portion of the belt to confirm that it cannot be pulled out (ALR properly functioning).

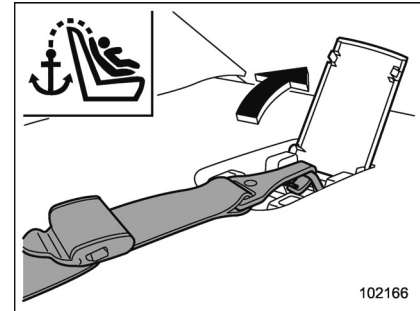

Sedan

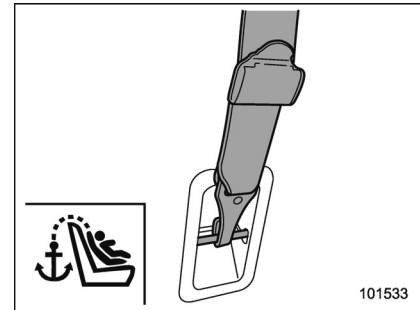

5-door models

10. Latch the top tether hook onto the tether anchorage that is located behind the rear seat and tighten the top tether firmly. For additional instructions, refer to

"Top tether anchorages" 1-36.

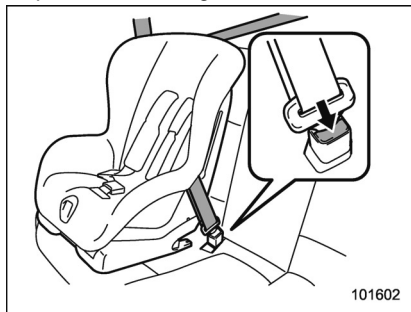

11. To remove the child restraint system, press the release button on the seatbelt buckle and allow the belt to retract completely. The belt will return to the ELR mode.

If you have installed a child restraint system for the **rear center seating position on a 5-door model**, when you remove the child restraint system, the seatbelt may not be restored to the ELR mode even if the seatbelt is retracted. In this case, lower the head restraint to the retracted position to allow the seatbelt to retract moreover. The seatbelt will return to the ELR mode.

Remember that the head restraint is not intended to be used at the lowest position

(retracted position). Therefore, when the rear center seat is occupied (including when a child restraint system is installed) next time, be sure to raise the head restraint to the extended position.

NOTE

When the child restraint system is no longer in use, remove it and restore the ELR function of the retractor. That function is restored by allowing the seatbelt to retract fully.

■ Installing a booster seat

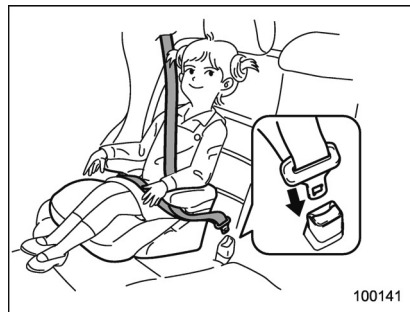

1. Place the booster seat in the rear seating position and sit the child on it. The child should sit well back on the booster seat.
2. Run the lap and shoulder belt through

or around the booster seat and the child following the instructions provided by its manufacturer.

3. Insert the tongue plate into the buckle until you hear a click. Take care not to twist the seatbelt.

Make sure the shoulder belt is positioned across the center of child's shoulder and that the lap belt is positioned as low as possible on the child's hips.

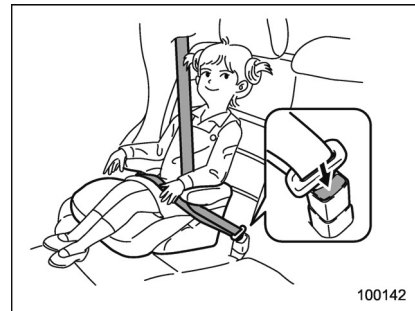

4. To remove the booster seat, press the release button on the seatbelt buckle and allow the belt to retract.

WARNING

- **Never use a belt that is twisted or reversed. In an accident, this can increase the risk or severity of**

injury to the child.

- Never place the shoulder belt under the child's arm or behind the child's back. If an accident occurs, this can increase the risk or severity of injury to the child.
- The seatbelt should fit snugly in order to provide full restraint. Loose fitting belts are not as effective in preventing or reducing injury.
- Place the lap belt as low as possible on the child's hips. A high-positioned lap belt will increase the risk of sliding under the lap belt and of the lap belt sliding up over the abdomen, and both can result in serious internal injury or death.
- Make sure the shoulder belt is positioned across the center of child's shoulder. Placing the shoulder belt over the neck may result in neck injury during sudden braking or in a collision.

■ Installation of child restraint systems by use of lower and tether anchorages (LATCH)

▼ Lower and tether anchorages

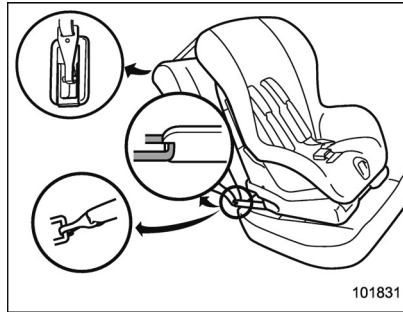

Some types of child restraint systems can be installed on the rear seat of your vehicle without use of the seatbelts. Such child restraint systems are secured to the designated anchorages provided on the vehicle body. The lower and tether anchorages are sometimes referred to as the LATCH system (Lower Anchors and Tethers for Children).



Your vehicle is equipped with four lower anchorages (bars) and three upper anchorages (tether anchorages) for accommodating such child restraint systems.

▽ Lower anchorages

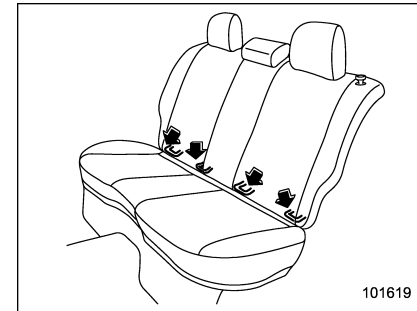

The lower anchorages (bars) are used for installing a child restraint system only on the rear seat window-side seating positions. For each window-side seating position, two lower anchorages are provided. Each lower anchorage is located where the seat cushion meets the seatback.

▽ **Tether anchorages**

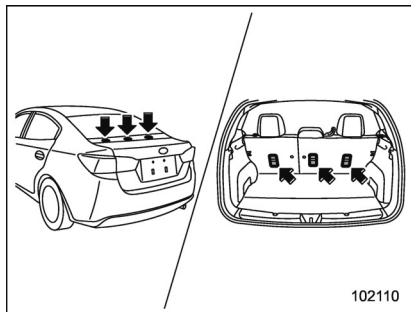

The tether anchorages (upper anchorages) are provided at the locations shown in the above illustration. For details, refer to “Top tether anchorages” 1-36.

▽ **To install a child restraint system using lower and tether anchorages**

To install a child restraint system using lower and tether anchorages, perform the following procedure.

WARNING

Before installing a child restraint system, be sure to confirm that the seatback is securely locked into place. Otherwise, in an accident, serious injury or death could result.

1. Shake the seatback slightly to confirm that it is securely locked into place.
 - It is possible to check whether the seatback is locked visually. If the seatback is locked into place, the red colored unlocking marker which is attached to the bottom of the lock release knob is invisible. For details, refer to “Folding down the rear seatback” 1-6.

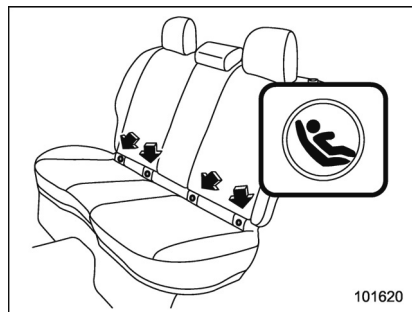

2. You will find marks “Ⓢ” at the bottom of the rear seat seatbacks. These marks indicate the positions of the lower anchorages (bars).

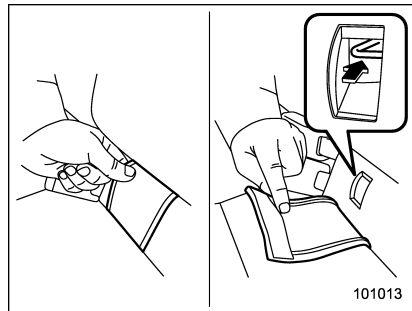

Remove the covers and locate the lower anchorages (bars).

3. Remove the rear seat head restraint. For details, refer to "Rear seats" ¶ 1-9.

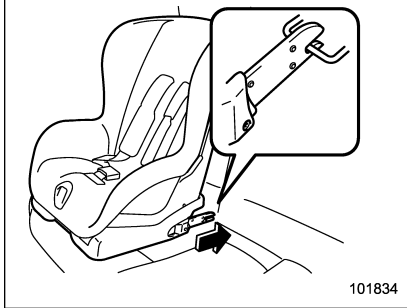

4. While following the instructions supplied by the child restraint system manufacturer, connect the lower hooks onto the lower anchorages located at "C" marks on the bottom of the rear seatback. When the hooks are connected, make sure the adjacent seatbelts are not caught.

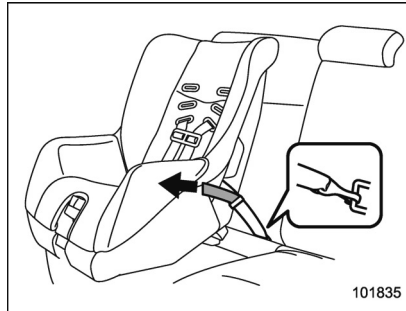

5. [If your child restraint system is of a flexible attachment type (which uses tether belts to connect the child restraint system properly to the lower anchorages)] While pushing the child restraint into the seat cushion, pull both left and right lower tether belts up to secure the child restraint system firmly by taking up the slack in the belt.

6. Latch the top tether hook onto the tether anchorage that is located behind the rear seat and tighten the top tether firmly. For additional instructions, refer to "Top tether anchorages" ¶ 1-36.

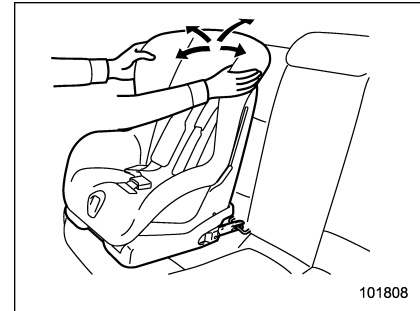

7. Before seating a child in the child restraint system, try to move it back and forth and right and left to verify that it is held securely in position.

8. To remove the child restraint system, follow the reverse procedures of installation.

If you have any question concerning this type of child restraint system, ask your SUBARU dealer.

■ Top tether anchorages

Your vehicle is equipped with three top tether anchorages so that a child restraint system having a top tether can be installed in the rear seat. When installing a child restraint system using top tether, proceed as follows, while observing the instructions by the child restraint system manufacturer.

Since a top tether can provide additional stability by offering another connection between a child restraint system and the vehicle, we recommend that you use a top tether whenever one is required or available.

▼ Anchorage location

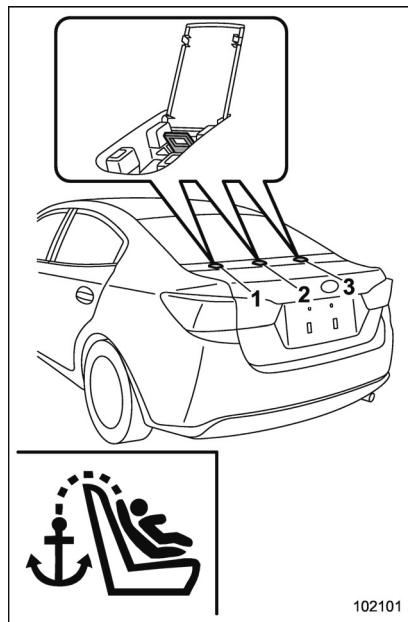

Sedan

- 1) For left seat
- 2) For center seat
- 3) For right seat

Three upper anchorages are installed on

the rear shelf behind the rear seat.

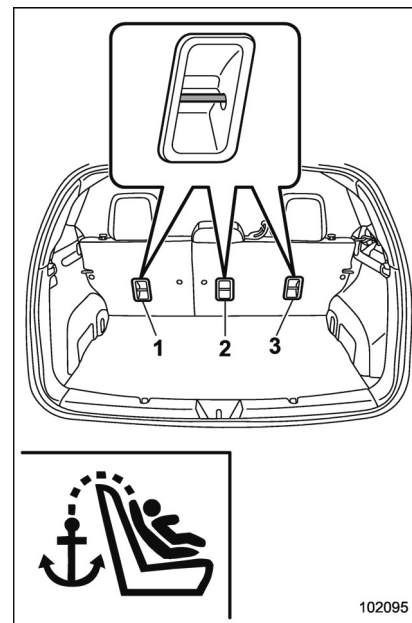

5-door models

- 1) For left seat
- 2) For center seat
- 3) For right seat

Three upper anchorages are installed on the back side of the rear seatback.

▼ To hook the top tether

CAUTION

- Except for the center seating position on 5-door models, remove the head restraint when mounting a child restraint system. Otherwise, it might be possible that the top tether cannot be fastened tightly.
- For the center seating position on 5-door models, raise the center head restraint to the extended position when mounting a child restraint system. Otherwise, it will be impossible to use the seatbelt guide that is attached to the head restraint correctly.

The seatbelt guide is essential for routing the belt webbing at the center seating position. For information about using the seatbelt guide, refer to "Rear center seatbelt on 5-door models" 1-16.

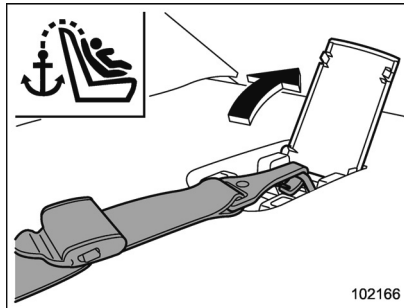

Sedan

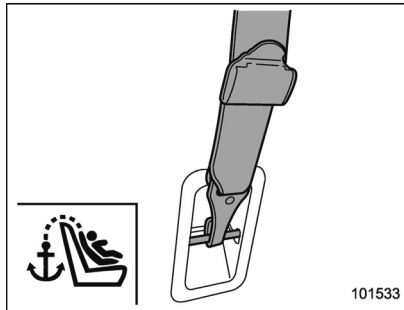

5-door models

1. Open the cover (sedan) and attach the top tether hook to the appropriate upper anchorage.

For the center seating position on 5-door models, route the top tether under the head restraint as illustrated below.

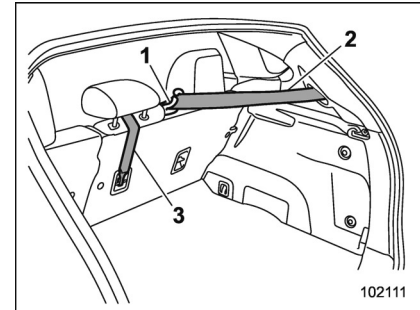

- 1) Seatbelt guide
- 2) Seatbelt of the center seating position
- 3) Top tether

2. Tighten the top tether securely.

Please contact your SUBARU dealer if you have any question regarding the installation of a child restraint system.

*SRS airbag (Supplemental Restraint System airbag)

*SRS: This stands for supplemental restraint system. This name is used because the airbag system supplements the vehicle's seatbelts.

Your vehicle is equipped with a supplemental restraint system in addition to a lap/shoulder belt at each front seating position and each rear window-side seating positions. The supplemental restraint system (SRS) consists of seven airbags. The configurations are as follows.

- Driver's and front passenger's **frontal airbags**
- Driver's and front passenger's **side airbags**
- **Curtain airbags** (for driver, front passenger, and window-side rear passengers)
- **Knee airbag** for driver

These SRS airbags are designed only as a supplement to the primary protection provided by the seatbelt.

The system also controls front seatbelt pretensioners. For operation instructions and precautions concerning the seatbelt pretensioner, refer to "Seatbelt pretensioners" 1-20.

■ General precautions regarding SRS airbag system

WARNING

- To obtain maximum protection in the event of an accident, the driver and all passengers must always wear seatbelts when in the vehicle. The SRS airbag is designed only to be a supplement to the primary protection provided by the seatbelt. It does not eliminate the need to fasten seatbelts. In combination with the seatbelts, it offers the best combined protection in case of a serious accident.

Not wearing a seatbelt increases the chance of severe injury or death in a crash even when the vehicle has the SRS airbag.

For instructions and precautions concerning the seatbelt system, refer to "Seatbelts" 1-11.

- The SRS side airbag and SRS curtain airbag are designed only to be a supplement to the primary protection provided by the seatbelt. They do not eliminate the need to fasten seatbelts. It is also important to wear your seatbelt

to help avoid injuries that can result when an occupant is not seated in a proper upright position.



100155

WARNING

- The SRS airbags deploy with considerable speed and force. Occupants who are out of proper position when the SRS airbag deploys could suffer very serious injuries. Because the SRS airbag needs enough space for deployment, the driver should always sit upright and well back in the seat as far from the steering wheel as practical while still maintaining full vehicle control

and the front passenger should move the seat as far back as possible and sit upright and well back in the seat.



WARNING

- Do not sit or lean unnecessarily close to either front door. The SRS side airbags are stored in both front seat seatbacks next to the door, and they provide protection by deploying rapidly (faster than the blink of an eye) in the event of a side impact or frontal collision. However, the force of SRS side airbag deployment may cause injuries if your head or other parts of the body are too

close to the SRS side airbag.

- Since your vehicle is equipped with SRS curtain airbags, do not sit or lean unnecessarily close to the front or rear door on either side. Also, do not put your head, arms or hands out of the window. The SRS curtain airbags on both sides of the cabin are stored in the roof side (between the front pillar and a point behind the rear quarter glass), and they provide protection by deploying rapidly (faster than the blink of an eye) in the event of a side impact, roll-over or frontal collision. However, the force of its deployment may cause injuries if your head is too close to it.
- Do not sit or lean unnecessarily close to the SRS airbag. Because the SRS airbag deploys with considerable speed – faster than the blink of an eye – and force to protect in high speed collisions, the force of an airbag can injure an occupant whose body is too close to SRS airbag.
It is also important to wear your seatbelt to help avoid injuries that can result when the SRS airbag contacts an occupant not

in proper position such as one thrown forward during pre-accident braking.

Even when properly positioned, there remains a possibility that an occupant may suffer minor injury such as abrasions and bruises to the face or arms because of the SRS airbag deployment force.



WARNING

- Do not rest your arm on either front door or its internal trim. You could be injured in the event of SRS side airbag deployment.
- Do not place any objects over or

near the SRS airbag cover or between you and the SRS airbag. If the SRS airbag deploys, these objects could interfere with its proper operation and could be propelled inside the vehicle, causing injury.

CAUTION

- When the SRS airbag deploys, some smoke will be released. This smoke could cause breathing problems for people with a history of asthma or other breathing trouble. If you or your passengers have breathing problems after SRS airbag deploys, get fresh air promptly.
- A deploying SRS airbag releases hot gas. Occupants could get burned if they come into direct contact with the hot gas.

NOTE

- When you sell your vehicle, we urge you to explain to the buyer that it is equipped with SRS airbags by alerting the buyer to the applicable section in this Owner's Manual.
- If the SRS airbag deploys, fuel

supply will be cut off to reduce the risk of fire caused by leaking fuel. For details about restarting of the engine, refer to "If your vehicle is involved in an accident" 9-21.

General precautions regarding SRS airbag system for accessories and any objects

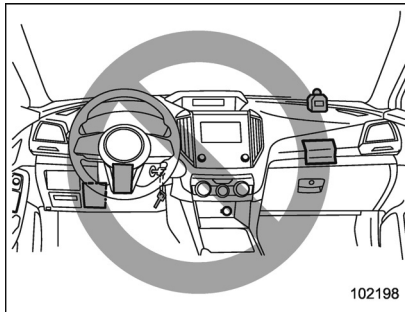

WARNING

- Do not put any objects over the steering wheel pad and dashboard. If the SRS frontal airbag deploys, these objects could interfere with its proper operation and could be propelled inside the vehicle, causing injury.

- Do not put any objects under the driver's side of the instrument panel. If the SRS knee airbag deploys, those objects could interfere with its proper operation and could be propelled inside the vehicle, causing injury.
- The key must not be attached to heavy, sharp or hard accessories, or another key. If the SRS knee airbag deploys, those objects could interfere with its proper operation and could be propelled inside the vehicle and cause injury.

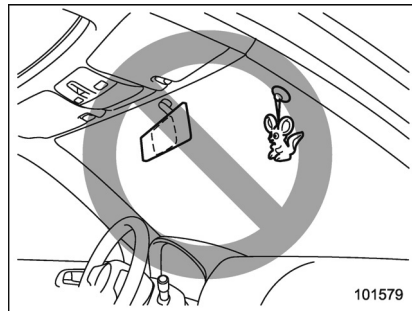

WARNING

Do not attach accessories to the windshield, or fit an extra-wide mirror over the inside rear view mirror. If the SRS airbag deploys, those objects could become projectiles that could seriously injure vehicle occupants.

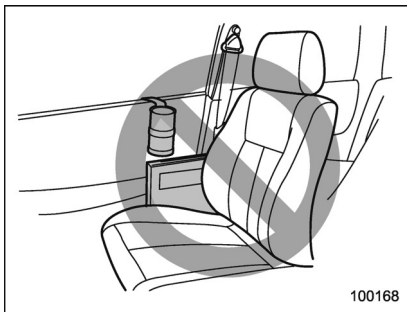

WARNING

- Do not attach accessories to the door trim or near either SRS side airbags and do not place objects near the SRS side airbags. In the event of SRS side airbag deployment, they could be propelled

dangerously toward the vehicle's occupants and cause injuries.

- Do not attach a hands-free microphone or any other accessory to a front pillar, a center pillar, a rear pillar, the windshield, a side window, an assist grip, or any other cabin surface that would be near a deploying SRS curtain airbag. A hands-free microphone or other accessory in such a location could be propelled through the cabin with great force by the curtain airbag, or it could prevent correct deployment of the curtain airbag. In either case, the result could be serious injuries.

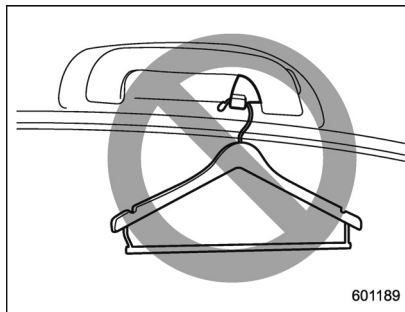

WARNING

Do not hang coat hangers or other hard or pointed objects on the coat hooks. If such items were hanging on the coat hooks during deployment of the SRS curtain airbags, they could cause serious injuries by coming off the coat hooks and being thrown through the cabin or by preventing deployment of the curtain airbags.

Before hanging clothing on the coat hooks, make sure there are no sharp objects in the pockets. Hang clothing directly on the coat hooks without using hangers.

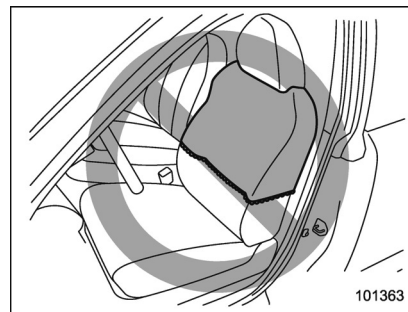

▲ WARNING

- Do not put any kind of clothes or other objects over either front seatback and do not attach labels or stickers to the front seat surface on or near the SRS side airbag. They could prevent proper deployment of the SRS side airbag, reducing protection available to the front seat's occupant.
- Do not install a seat cover unless it is a genuine SUBARU seat cover exclusively designed for use with the SRS airbag. Even when using a genuine SUBARU seat cover, the SRS side airbag system may not function normally if the seat cover is not installed correctly.

■ General precautions regarding SRS airbag system and children



▲ WARNING

Place children in the rear seat properly restrained at all times. The SRS airbag deploys with considerable speed and force and can injure or even kill children, especially if they are not restrained or improperly restrained. Because children are lighter and weaker than adults, their risk of being injured from deployment is greater.

For that reason, we strongly recommend that ALL children (including those in child seats and those that

have outgrown child restraint devices) sit in the REAR seat properly restrained at all times in a child restraint device or in a seatbelt, whichever is appropriate for the child's age, height and weight.

Secure ALL types of child restraint devices (including forward facing child seats) in the REAR seats at all times.

According to accident statistics, children are safer when properly restrained in the rear seating positions than in the front seating positions.

For instructions and precautions concerning the child restraint system, refer to "Child restraint systems" 1-25.

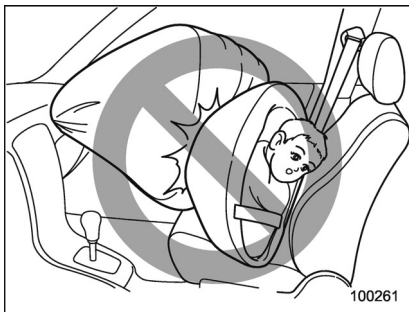

⚠ WARNING

NEVER INSTALL A FORWARD OR REARWARD FACING CHILD SEAT IN THE FRONT SEAT. DOING SO RISKS SERIOUS INJURY OR DEATH TO THE CHILD BY PLACING THE CHILD'S HEAD TOO CLOSE TO THE SRS AIRBAG.

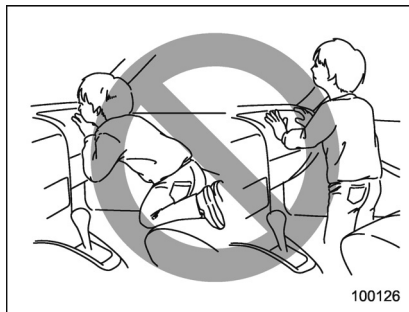

⚠ WARNING

Never allow a child to stand up or kneel on the front passenger's seat. The SRS airbag deploys with considerable force and can injure or even kill the child.

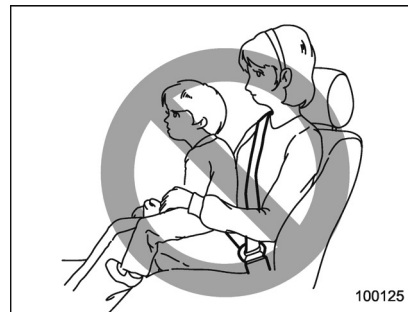

⚠ WARNING

Never hold a child on your lap or in your arms. The SRS airbag deploys with considerable force and can injure or even kill the child.

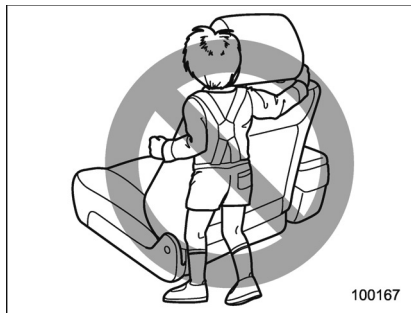
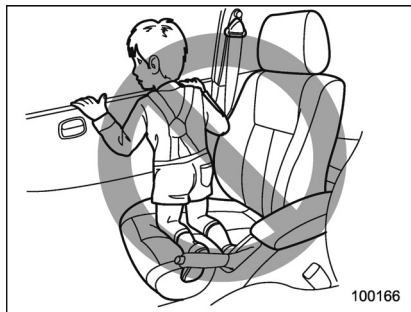

⚠ WARNING

- Never allow a child to do the following.
 - Kneel on any passenger's seat facing the side window
 - Wrap his/her arms around the front seat seatback
 - Put his/her head, arms or other parts of the body out of the window

In the event of an accident, the force of SRS side airbag and/or SRS curtain airbag deployment could injure the child seriously because his/her head, arms or other parts of the body are too close to the SRS side airbag and/or SRS curtain airbag.

- Since your vehicle is also equipped with a front passenger's SRS frontal airbag, children should be placed in the rear seat anyway and should be properly restrained at all times.

■ Components

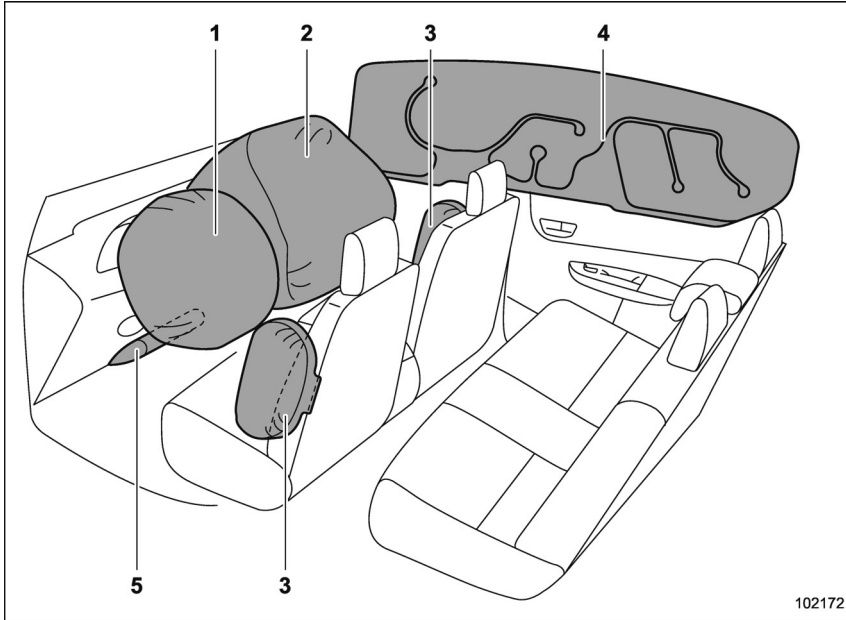

- 1) Driver's SRS frontal airbag
- 2) Front passenger's SRS frontal airbag
- 3) SRS side airbag
- 4) SRS curtain airbag
- 5) SRS knee airbag

The SRS airbags are stowed in the following locations.

Driver's SRS frontal airbag: in the center portion of the steering wheel
A "SRS AIRBAG" mark is located at the pad of the airbag.

Front passenger's SRS frontal airbag: near the top of the dashboard under the "SRS AIRBAG" mark

SRS side airbag: in the door side of each front seat seatback which bears an "SRS AIRBAG" label

SRS curtain airbag: in the roof side (between the front pillar and a point behind the rear quarter glass)
"SRS AIRBAG" marks are located at the top of each center pillar.

SRS knee airbag: under the steering column
A "SRS AIRBAG" mark is located at the door of the airbag.

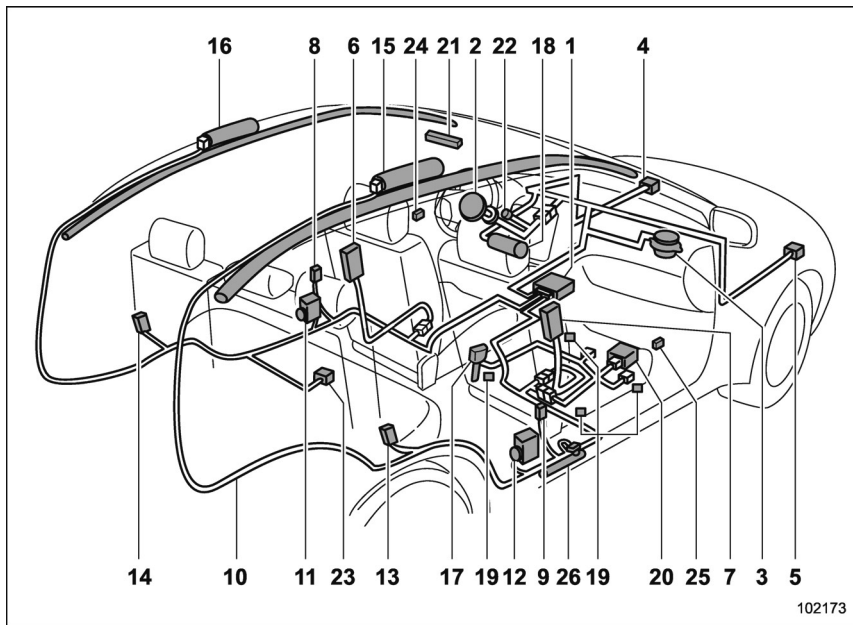

- 11) Seatbelt pretensioner (driver's side)
- 12) Seatbelt pretensioner and adaptive force limiter (front passenger's side)
- 13) Curtain airbag sensor (rear wheel house right-hand side)
- 14) Curtain airbag sensor (rear wheel house left-hand side)
- 15) Curtain airbag module (right-hand side)
- 16) Curtain airbag module (left-hand side)
- 17) Seatbelt buckle switch (front passenger's side)
- 18) Knee airbag module (driver's side)
- 19) Front passenger's occupant detection system sensor
- 20) Front passenger's occupant detection control module
- 21) Front passenger's frontal airbag ON and OFF indicator
- 22) SRS airbag system warning light
- 23) Satellite safing sensor (under the rear center seat)
- 24) Front door impact sensor (left-hand side)
- 25) Front door impact sensor (right-hand side)
- 26) Lap belt pretensioner (front passenger's side)

- 1) Airbag control module (including impact sensor and rollover sensor)
- 2) Frontal airbag module (driver's side)
- 3) Frontal airbag module (front passenger's side)
- 4) Front sub sensor (left-hand side)
- 5) Front sub sensor (right-hand side)
- 6) Side airbag module (driver's side)
- 7) Side airbag module (front passenger's side)
- 8) Side airbag sensor (center pillar left-hand side)
- 9) Side airbag sensor (center pillar right-hand side)
- 10) Airbag wiring

102173

■ SUBARU advanced frontal airbag system

Your vehicle is equipped with a SUBARU advanced frontal airbag system that complies with the new advanced frontal airbag requirements in the amended Federal Motor Vehicle Safety Standard (FMVSS) No. 208.

The SUBARU advanced frontal airbag system automatically determines the deployment force of the driver's SRS frontal airbag at the time of deployment as well as whether or not to activate the front passenger's SRS frontal airbag and, if activated, the deployment force of the SRS frontal airbag at the time of deployment.



Your vehicle has warning labels on the driver's and front passenger's sun visors

beginning with the phrase "EVEN WITH ADVANCED AIR BAGS" and a tag attached to the glove box lid beginning with the phrase "Even with Advanced Air Bags". Make sure that you carefully read the instructions on the warning labels and tag.

Always wear your seatbelt. The SUBARU advanced frontal airbag system is a supplemental restraint system and must be used in combination with a seatbelt. All occupants should wear a seatbelt or be seated in an appropriate child restraint system.

For the locations of the SRS airbags, refer to "Components" 1-45.

In a moderate to severe frontal collision, the following components deploy.

- SRS frontal airbag for driver
- SRS frontal airbag for front passenger
- SRS knee airbag for driver
- SRS curtain airbag*¹

*1: When an offset frontal collision that is severe enough to deploy the front airbag occurs.

These components supplement the seatbelts by reducing the impact to the occupant's head, chest and knees.

▼ Driver's SRS frontal airbag

The driver's SRS frontal airbag uses a dual stage inflator. The inflator operates in different ways depending on the severity of impact.

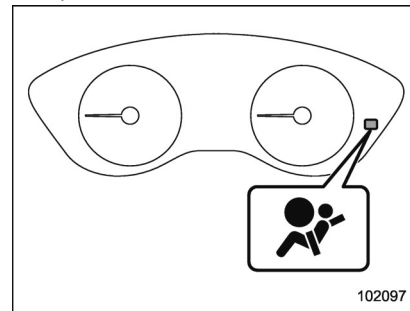

SRS airbag system warning light

Have the system inspected by your SUBARU dealer immediately if the SRS airbag system warning light illuminates.

NOTE

The driver's SRS side airbag and SRS curtain airbag are not controlled by the SUBARU advanced frontal airbag system.

▼ **Front passenger's SRS frontal airbag**

The front passenger's SRS frontal airbag uses a dual stage inflator. The inflator operates in different ways depending on the severity of impact.

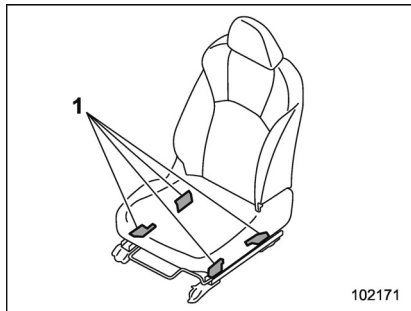

1) Occupant detection sensors

The occupant detection system sensors are installed between the seat and seat rails, and monitor the physique and posture of the front passenger. Using this information, the occupant detection system determines whether the front passenger's SRS frontal airbag should be deployed or not.

The occupant detection system may not inflate the front passenger's SRS frontal airbag even when the driver's SRS frontal

airbag deploys. This is normal. In this case, although the front passenger's SRS frontal airbag does not operate, the front passenger's seatbelt pretensioner operates with the driver's seatbelt pretensioner. For details about the seatbelt pretensioner, refer to "Seatbelt pretensioners" Ⓞ 1-20.

CAUTION

Observe the following precautions. Failure to do so may prevent the SUBARU advanced frontal airbag system from functioning correctly or cause the system to fail.

- Do not apply any strong impact to the front passenger's seat such as by kicking.
- Do not let rear passengers rest their feet between the front seatback and seat cushion.
- Do not spill liquid on the front passenger's seat. If liquid is spilled, wipe it off immediately.
- Do not remove or disassemble the front passenger's seat.
- Do not install any accessory (such as an audio amplifier) other than a genuine SUBARU accessory under the front passenger's

seat.

- Do not place anything (shoes, umbrella, etc.) under the front passenger's seat.
- Do not place any objects (books, etc.) around the front passenger's seat.
- Do not use the front passenger's seat with the head restraint removed.
- Do not leave any articles on the front passenger's seat or the seatbelt tongue and buckle engaged when you leave your vehicle.
- Do not put sharp object(s) on the seat or pierce the seat upholstery.
- Do not place a magnet near the seatbelt buckle and the seatbelt retractor.
- Do not use front seats with their forward-backward position and seatback not being locked into place securely. If any of them are not locked securely, adjust them again. For adjusting procedure, refer to "Forward and backward adjustment" Ⓞ 1-5 and "Reclining the seatback" Ⓞ 1-5.

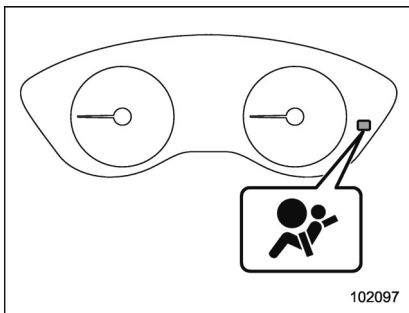

SRS airbag system warning light

If the seatbelt buckle switch and/or front passenger's occupant detection system have failed, the SRS airbag system warning light will illuminate. Have the system inspected by your SUBARU dealer immediately if the SRS airbag system warning light illuminates.

If your vehicle has sustained impact, this may affect the proper function of the SUBARU advanced frontal airbag system. Have your vehicle inspected at your SUBARU dealer. Do not use the front passenger's seat while driving the vehicle to your SUBARU dealer.

NOTE

The front passenger's SRS side airbag and SRS curtain airbag are not controlled by the SUBARU advanced frontal airbag system.

▼ **Passenger's frontal airbag ON and OFF indicators**



ON / : Front passenger's frontal airbag ON indicator

OFF / : Front passenger's frontal airbag OFF indicator

Refer to "Front passenger's frontal airbag ON and OFF indicators" 3-16.

▼ **Occupant detection system**

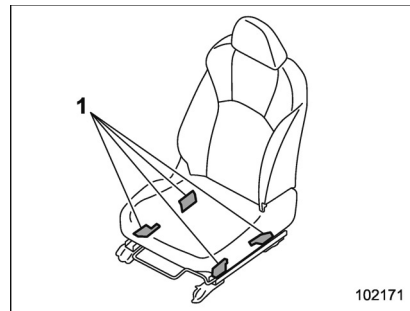

1) Occupant detection sensors

The occupant detection system sensors are installed between the seat and seat rails, and monitor the physique and posture of the front passenger. Using this information, the occupant detection system determines whether the front passenger's SRS frontal airbag should be deployed or not.

WARNING

Do not kick the front passenger seat or subject it to severe impact. Otherwise, the SRS airbag system warning light may illuminate to indicate a malfunction of the front passenger occupant detection sys-

tem. In this case, contact your SUBARU dealer immediately.

CAUTION

Electrical devices, such as cell phones, laptops, portable music players, or electronic games, especially when connected to the accessory power outlet and placed on the front passenger's seat or used by the person sitting in the front passenger's seat, may affect the operation of the occupant detection system. If either of the following situations occurs when using an electronic device in the vehicle, at first try to relocate that device to avoid it creating any interference.

- The SRS airbag system warning light
- The front passenger's frontal airbag ON and OFF indicators operate erratically.

If the device continues to cause interference, the use of that device in the vehicle should be discontinued.

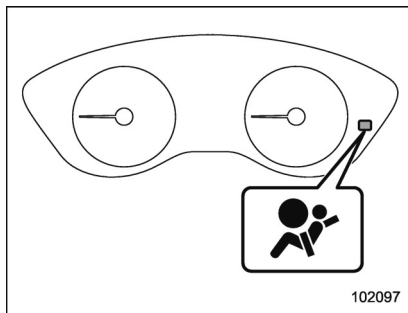

SRS airbag system warning light

If the front passenger's seat cushion is wet, this may adversely affect the ability of the system to determine deployment. Wipe off liquid from the seat, let the seat dry naturally and then check the SRS airbag system warning light.





ON / : Front passenger's frontal airbag ON indicator

OFF / : Front passenger's frontal airbag OFF indicator

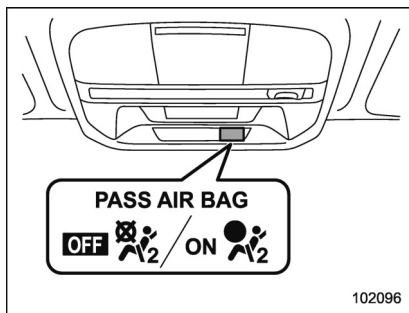
If the front passenger's frontal airbag ON and OFF indicators do not work properly even when the front passenger's seat is dry, do not allow anyone to sit on the front passenger's seat and have the occupant detection system checked by your SUBARU dealer.



ON / : Front passenger's frontal airbag ON indicator

OFF / : Front passenger's frontal airbag OFF indicator

Also, if luggage or electronic devices are placed on the front passenger's seat, this may adversely affect the ability of the system to determine deployment. This may prevent the front passenger's frontal airbag ON and OFF indicators from working properly. Check that the indicators work properly.

When the OFF indicator turns off and the ON indicator illuminates, the front passenger's frontal airbag may deploy during a collision. Remove luggage and electronic devices from the front passenger's seat.

▼ Conditions in which front passenger's SRS frontal airbag is not activated

The front passenger's SRS frontal airbag will not be activated when any of the following conditions are met regarding the front passenger's seat:

- The seat is empty.
- The seat is equipped with an appropriate child restraint system and an infant or a child is restrained in it. (See WARNING that follows.)
- The front passenger's occupant detection system is malfunctioning.

WARNING

NEVER INSTALL A FORWARD OR REARWARD FACING CHILD SEAT IN THE FRONT PASSENGER'S SEAT EVEN IF THE FRONT PASSENGER'S SRS FRONTAL AIRBAG IS DEACTIVATED. Be sure to install it in the REAR seat in a correct manner. Also, it is strongly recommended that any forward facing child seat or booster seat be installed in the REAR seat, and that even children who have outgrown a child restraint system be also seated in the REAR seat. This is because children sitting in the front

passenger's seat may be killed or severely injured should the front passenger's SRS frontal airbag deploy. REAR seats are the safest place for children.

CAUTION

When the front passenger's seat is occupied by an infant in an appropriate child restraint system, observe the following precautions. Failure to do so may interfere with the proper operation of the occupant detection system, activating the front passenger's SRS frontal airbag even though that seat is occupied by the infant in the child restraint system.

- Do not place any article (including electronic devices) on the seat other than the infant in the child restraint system.
- Do not place more than one infant in the child restraint system.

- ▽ If the front passenger's frontal airbag ON indicator illuminates and the OFF indicator turns off even when an infant or a small child is in a child restraint system (including booster seat)



ON / : Front passenger's frontal airbag ON indicator

OFF / : Front passenger's frontal airbag OFF indicator

1. Turn the ignition switch to the "LOCK"/"OFF" position.
2. Remove the child restraint system from the seat.
3. By referring to the child restraint manufacturer's recommendations as well as the child restraint system installation procedures in "Child restraint systems" ¶ 1-25, correctly install the child restraint

system.

4. Turn the ignition switch to the "ON" position and make sure that the front passenger's frontal airbag ON indicator turns off and the OFF indicator illuminates.

If still the ON indicator remains illuminated while the OFF indicator turns off, take the following actions.

- Ensure that no article is placed on the seat other than the child restraint system and the child occupant.
- Ensure that the backward-forward position and seatback of front passenger's seat are locked into place securely by moving the seat back and forth.

If the ON indicator still remains illuminated while the OFF indicator turns off after taking relevant corrective actions described above, relocate the child restraint system to the rear seat and immediately contact your SUBARU dealer for an inspection.

NOTE

When a child who has outgrown a child restraint system or a small adult is seated in the front passenger's seat, the SUBARU advanced frontal airbag system may or may not activate the front passenger's SRS frontal airbag

depending on the occupant's seating posture. Children should always wear a seatbelt when sitting in the seat irrespective of whether the airbag is deactivated or activated. If the front passenger's SRS frontal airbag is activated (the ON indicator remains illuminated while the OFF indicator turns off), take the following action.

- Ensure that no article is placed on the seat other than the occupant.

If the ON indicator still remains illuminated while the OFF indicator turns off despite the fact that the actions noted above have been taken, seat the child/small adult in the rear seat and immediately contact your SUBARU dealer for an inspection. Even if the system has passed the dealer inspection, it is recommended that on subsequent trips the child/small adult always take the rear seat.

Children who have outgrown a child restraint system should always wear the seatbelt irrespective of whether the airbag is deactivated or activated.

▼ Conditions in which front passenger's SRS frontal airbag is activated

The front passenger's SRS frontal airbag will be activated for deployment upon impact when any of the following conditions are met regarding the front passenger's seat.

- When the seat is occupied by an adult.
- When certain items (e.g. jug of water) are placed on the seat.

▽ If the passenger's frontal airbag OFF indicator illuminates and the ON indicator turns off even when the front passenger's seat is occupied by an adult

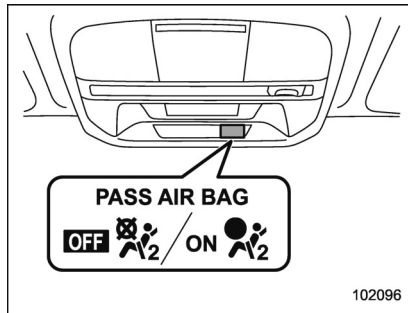

ON / : Front passenger's frontal airbag ON indicator

OFF / : Front passenger's frontal airbag OFF indicator

This can be caused by the adult incorrectly sitting in the front passenger's seat.

1. Turn the ignition switch to the "LOCK"/"OFF" position.
2. Ask the front passenger to set the seatback to the upright position, sit up straight in the center of the seat cushion, correctly fasten the seatbelt, position his/her legs out forward, and adjust the seat to the rearmost position.

3. Turn the ignition switch to the "ON" position.

If the OFF indicator remains illuminated while the ON indicator remains off, take the following actions.

1. Turn the ignition switch to the "LOCK"/"OFF" position.
2. Make sure that the front passenger does not use a blanket, seat cushion, seat cover, seat heater or massager, etc.
3. If wearing excessive layers of clothing, the front passenger should remove any unnecessary items before sitting in the front passenger's seat, or should sit in a rear seat.
4. Turn the ignition switch to the "ON" position and wait 6 seconds to allow the system to complete self-checking. Following the system check, both indicators turn off for 2 seconds. Now, the ON indicator should illuminate while the OFF indicator remains off.

If the OFF indicator still remains illuminated while the ON indicator remains off, ask the occupant to move to the rear seat and immediately contact your SUBARU dealer for an inspection.

▼ Operation

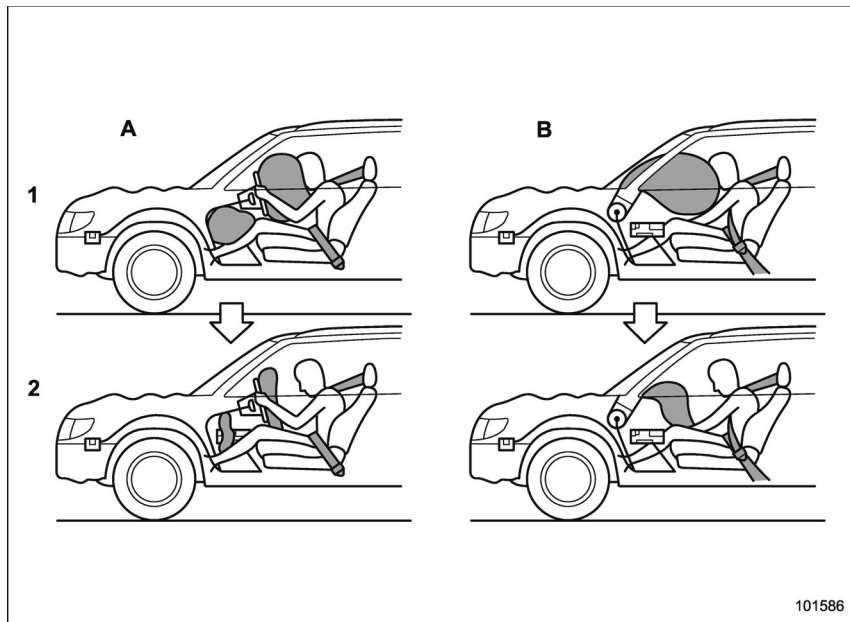

- A) Driver's side
- B) Passenger's side
- 1) SRS AIRBAGs deploy as soon as a collision occurs.
- 2) After deployment, SRS AIRBAGs start to deflate immediately so that the driver's vision is not obstructed.

The SRS airbags can function only when the ignition switch is in the "ON" position.

The SUBARU advanced frontal airbag system is designed to determine the activation or deactivation condition of the front passenger's SRS frontal airbag depending on the characteristic of item (s) or person on the front passenger's seat monitored by the front passenger's occupant detection system sensor. For this reason, only the driver's SRS frontal airbag may deploy in the event of a collision, but this does not mean failure of the system.

If the following sensors detect a predetermined amount of force during a frontal collision, the control module sends signals to the airbag module(s) (only driver's module or both driver's and front passenger's modules) instructing the module(s) to inflate the SRS frontal airbag(s).

- the front sub sensors
- the impact sensors in the airbag control module

On the driver's side, the SRS knee airbag also inflates with the SRS frontal airbag.

The driver's and front passenger's SRS frontal airbags use dual stage inflators. The two inflators of each airbag are triggered either sequentially or simultaneously, depending on the severity of impact, in the case of the driver's SRS frontal airbag and depending on the severity of impact and the characteristic of item(s) or person on the seat in the case of the front passenger's SRS frontal airbag.

▼ After deployment

After deployment, the SRS airbag immediately starts to deflate so that the driver's vision is not obstructed and the driver's ability to maintain control of the vehicle is not impaired. The time required from detecting impact to the deflation of the SRS airbag after deployment is shorter than the blink of an eye.

Both when only the driver's SRS frontal airbag deploys and the driver's and front passenger's SRS frontal airbags deploy, the driver's and front passenger's seatbelt pretensioners operate at the same time.

When the SRS airbag deploys, a sudden, fairly loud inflation noise will be heard and some smoke will be released. These occurrences are a normal result of the deployment. This smoke does not indicate a fire in the vehicle.

⚠ CAUTION

Do not touch the SRS airbag system components around the steering wheel and dashboard with bare hands right after deployment. Doing so can cause burns because the components can be very hot as a result of deployment.

▼ Example of the type of accident

The driver's SRS frontal airbag and front passenger's SRS frontal airbag are designed as follows.

- to deploy in the event of an accident involving a moderate to severe frontal collision
- to function on a one-time-only basis

The driver's SRS frontal airbag and front passenger's SRS frontal airbag are not designed as follows.

- to deploy in most lesser frontal impacts^{*1}
- to deploy in most side or rear impacts or in most rollover accidents^{*2}

*1: Because the necessary protection can be achieved by the seatbelt alone.

*2: Because deployment of only the driver's SRS frontal airbag or both the driver's and front

passenger's SRS frontal airbags would not protect the occupant in those situations.

SRS airbag deployment depends on the level of force experienced in the passenger compartment during a collision. That level differs from one type of collision to another, and it may have no bearing on the visible damage done to the vehicle itself.

▽ Example of accident in which the driver's/driver's and front passenger's SRS frontal airbag(s) will most likely deploy

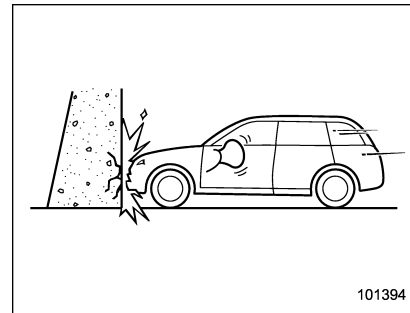

A head-on collision against a thick concrete wall at a vehicle speed of 12 to 19 mph (20 to 30 km/h) or higher activates only the driver's SRS frontal airbag or both driver's and front passenger's SRS frontal

airbags. The airbag(s) will also be activated when the vehicle is exposed to a frontal impact similar in fashion and magnitude to the collision described above.

▽ **Examples of the types of accidents in which it is possible that the driver's/driver's and front passenger's SRS frontal airbag(s) will deploy**

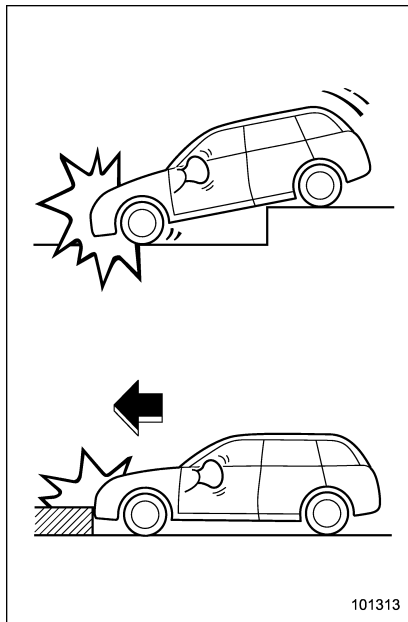

Only the driver's SRS frontal airbag or both driver's and front passenger's SRS frontal airbags may be activated when the vehicle sustains a hard impact in the undercarriage area from the road surface (such as when the vehicle plunges into a deep ditch, is severely impacted or knocked hard against an obstacle on the road such as a curb).

▽ **Examples of the types of accidents in which deployment of the driver's/ driver's and front passenger's SRS frontal airbag(s) is unlikely to occur**

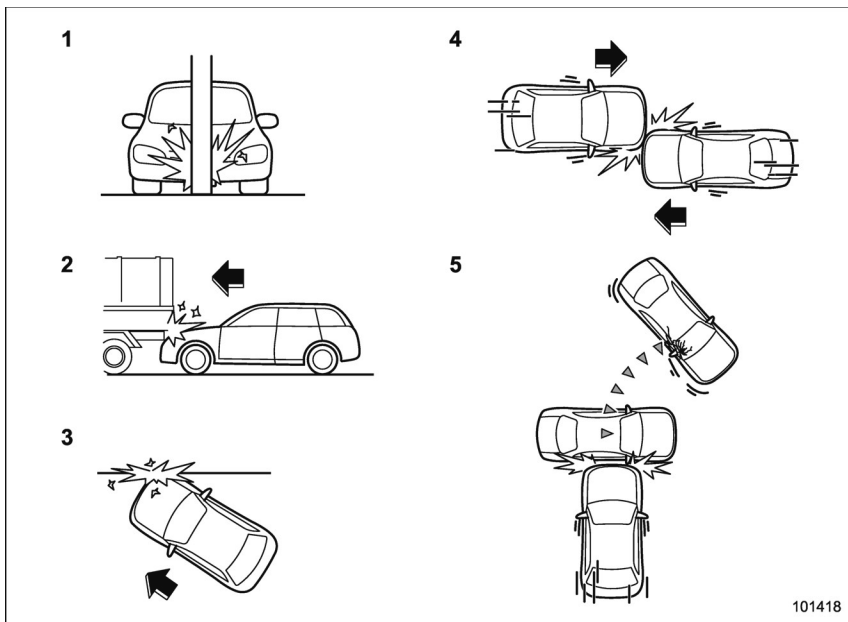

- 1) The vehicle strikes an object, such as a telephone pole or sign pole.
- 2) The vehicle slides under the load bed of a truck.
- 3) The vehicle sustains an oblique offset frontal impact.
- 4) The vehicle sustains an offset frontal collision.
- 5) The vehicle strikes an object that can move or deform, such as a parked vehicle.

There are many types of collisions which might not necessarily require deployment of driver's/driver's and front passenger's SRS frontal airbag(s). In the event of accidents like those illustrated, the driver's/driver's and front passenger's SRS frontal airbag(s) may not deploy depending on the level of accident forces involved.

- ▽ **Examples of the types of accidents in which the driver's/driver's and front passenger's SRS frontal airbag(s) are not designed to deploy in most cases**

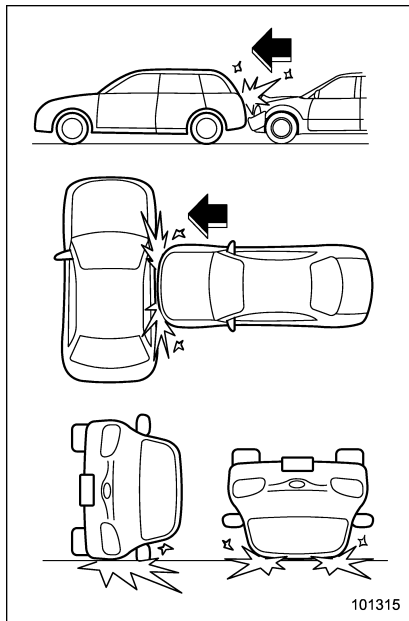

The driver's and front passenger's SRS

frontal airbags are not designed to deploy in most of the following cases.

- If the vehicle is struck from the side or from behind
- If the vehicle rolls onto its side or roof
- If the vehicle is involved in a low-speed frontal collision

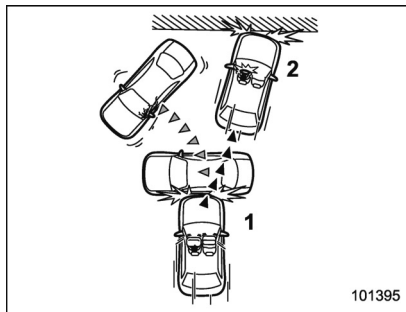

- 1) First impact
- 2) Second impact

In an accident where the vehicle is impacted more than once, the driver's and/or front passenger's SRS frontal airbag(s) will deploy only once on the first impact.

Example: In the case of a double collision, first with another vehicle, then against a concrete wall in immediate succession,

once either or both of the driver's and front passenger's SRS frontal airbags is/are activated on the first impact, it/they will not be activated on the second impact.

■ SRS side airbag and SRS curtain airbag



▼ SRS side airbag

The SRS side airbag is stored in the door side of each front seat seatback, which bears an "SRS AIRBAG" label.

In a moderate to severe side impact collision, the SRS side airbag on the impacted side of the vehicle deploys between the occupant and the door panel and supplements the seatbelt by reducing the impact on the occupant's chest and waist. The SRS side airbag operates only

for front seat occupants.

▼ SRS curtain airbag

Your vehicle is equipped with a SUBARU SRS curtain airbag system that complies with the Federal Motor Vehicle Safety Standard (FMVSS) No. 226.

The SRS curtain airbag on each side of the cabin is stored in the roof side (between the front pillar and a point over the rear seat). An "SRS AIRBAG" mark is located at the top of each center pillar.

In a moderate to severe side impact collision, the SRS curtain airbag on the impacted side of the vehicle deploys between the occupant and the side window and supplements the seatbelt by reducing the impact on the occupant's head.

In a rollover, SRS curtain airbags on both sides of the vehicle deploy between the occupant and the side window and supplement the seatbelt by reducing the impact to the occupant's head.

In an offset frontal collision, SRS curtain airbags on both sides of the vehicle deploy between the occupant and the side window and supplement the seatbelt by reducing the impact to the occupant's head and chest.

▼ Operation

The SRS side airbag and SRS curtain airbag can function only when the ignition switch is in the "ON" position.

The following airbags deploy independently of each other since each has its own impact sensor.

- Driver's SRS side airbag
- Front passenger's SRS side airbag
- SRS curtain airbag (right-hand side)
- SRS curtain airbag (left-hand side)

Therefore, they may not both deploy in the same accident. Also, the SRS side airbag and SRS curtain airbag deploys independently of the driver's and front passenger's SRS frontal airbags in the steering wheel and instrument panel.

An impact sensor, which senses impact force, is located in each of the following locations.

- In the left and right front doors
- In the left and right center pillars
- In the left and right rear wheel houses
- Under the rear center seat

A rollover sensor is also located inside the airbag control module.

▼ In cases of rollover accident or side collisions, the following components will operate simultaneously

Impact sensors affected		SRS side airbags		SRS curtain airbags		Seatbelt pretensioner (shoulder belt pretensioner only)	
		Impacted side	Non-impacted side	Impacted side	Non-impacted side	Impacted side	Non-impacted side
Both of the sensors together sense an impact force	Impact sensor in front doors	○	-	○	-	○	-
	Impact sensor under rear center seat						
Both of the sensors together sense an impact force	Impact sensor in center pillars	○	-	○	-	-	-
	Impact sensor under rear center seat						
Both of the sensors together sense an impact force	Impact sensor in rear wheel houses	-	-	○	-	-	-
	Impact sensor under rear center seat						
Rollover sensor in airbag control module		-		○	○	○	○

○: Activated
 -: Not activated

▼ After deployment

After the deployment, the SRS side airbag immediately starts to deflate. The time required from detection of an impact to deflation of an SRS side airbag after deployment is shorter than the blink of an eye.

The SRS curtain airbag remains inflated for a while following deployment then slowly deflates.

The SRS side airbag and SRS curtain airbag deploy even when no one occupies the seat on the side on which an impact is applied.

When the SRS side airbag and SRS curtain airbag deploy, a sudden, fairly loud inflation noise will be heard and some smoke will be released. These occurrences are a normal result of the deployment. This smoke does not indicate a fire in the vehicle.

CAUTION

Do not touch the SRS side airbag system components around the front seat seatback with bare hands right after deployment. Doing so can cause burns because the components can be very hot as a result of deployment.

After deployment, do not touch any part of the SRS curtain airbag system (from the front pillar to the part of the roof side over the rear seat). Doing so can cause burns because the components can be very hot as a result of deployment.

▼ Example of the type of accident

The SRS side airbag and SRS curtain airbag are designed as follows:

- to deploy in the event of an accident involving a moderate to severe side impact collision
- to function on a one-time-only basis.

The SRS side airbag and SRS curtain airbag are not designed to deploy in the following cases:

- in most lesser side impact
- in most frontal or most rear impacts (because the SRS side airbag and SRS curtain airbag deployment would not protect the occupant in those situations)

The SRS curtain airbags are also designed to deploy when the vehicle is in an extremely inclined state such as during a rollover. They are not designed to deploy in most lesser inclined state.

SRS side airbag and SRS curtain airbag deployment depend on the level of force

experienced in the passenger compartment during a side impact collision. That level differs from one type of collision to another, and it may have no bearing on the visible damage done to the vehicle itself.

- ▼ **Example of the type of accident in which the SRS side airbag will most likely deploy.**

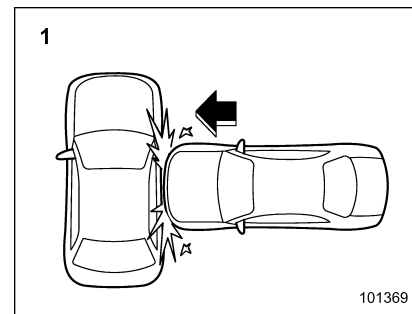

- 1) A severe side impact near the front seat.

▽ **Examples of the types of accidents in which the SRS curtain airbag will most likely deploy.**

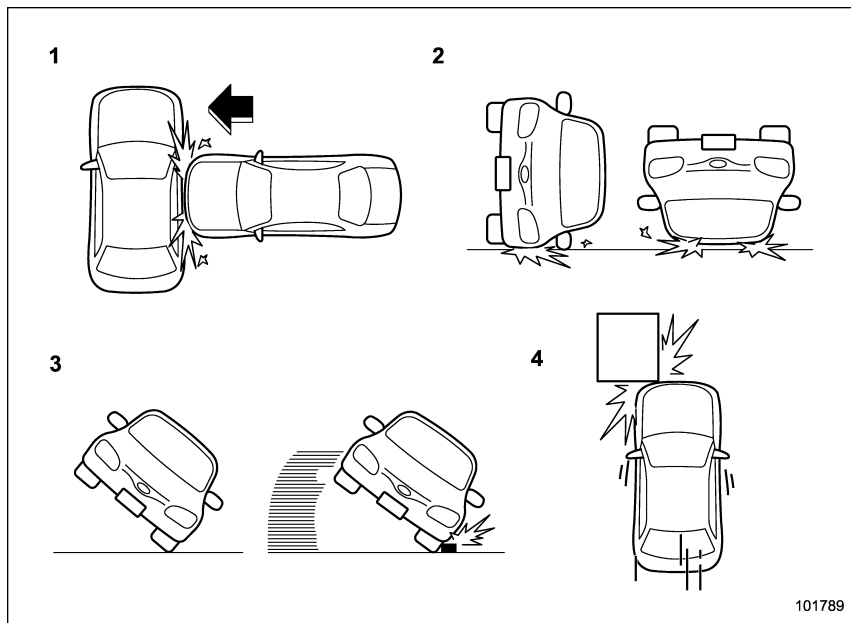

- 1) The vehicle is involved in a severe side impact near the front seat or the rear seat.
- 2) The vehicle rolls onto its side or the roof.
- 3) The angle of vehicle tip-up is marginal or the skidding vehicle's tires hit a curb-stone laterally.
- 4) An offset frontal collision that is severe enough to deploy the front airbag.

▽ Examples of the types of accidents in which it is possible that the SRS side airbag and the SRS curtain airbag will deploy.

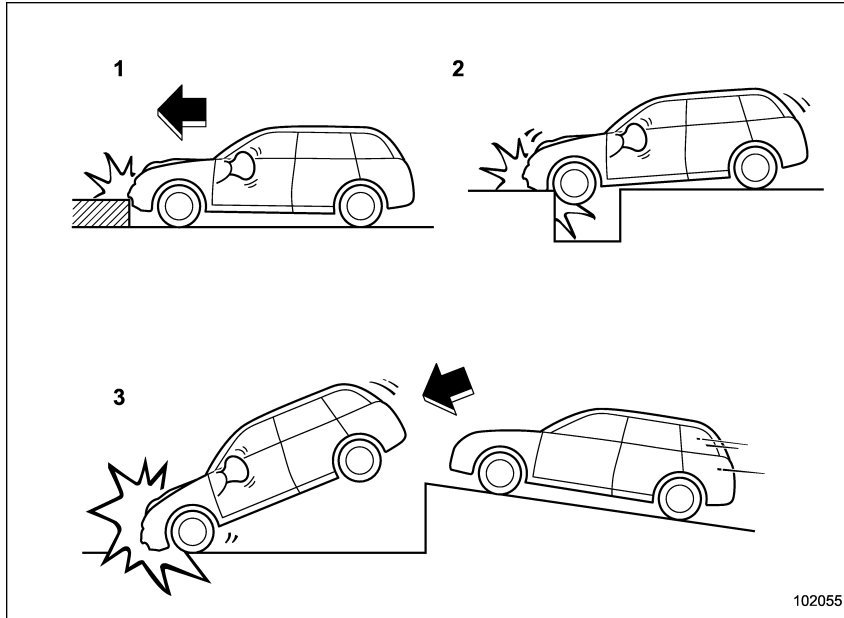

- 1) Hitting a curb, edge of pavement or hard surface
- 2) Falling into or jumping over a deep hole
- 3) Landing hard or vehicle falling

It is possible that the SRS side and curtain airbags will deploy if a serious impact occurs to the underside of your vehicle. Some examples are shown in the illustration.

▽ Examples of the types of accidents in which the SRS side airbag is unlikely to deploy.

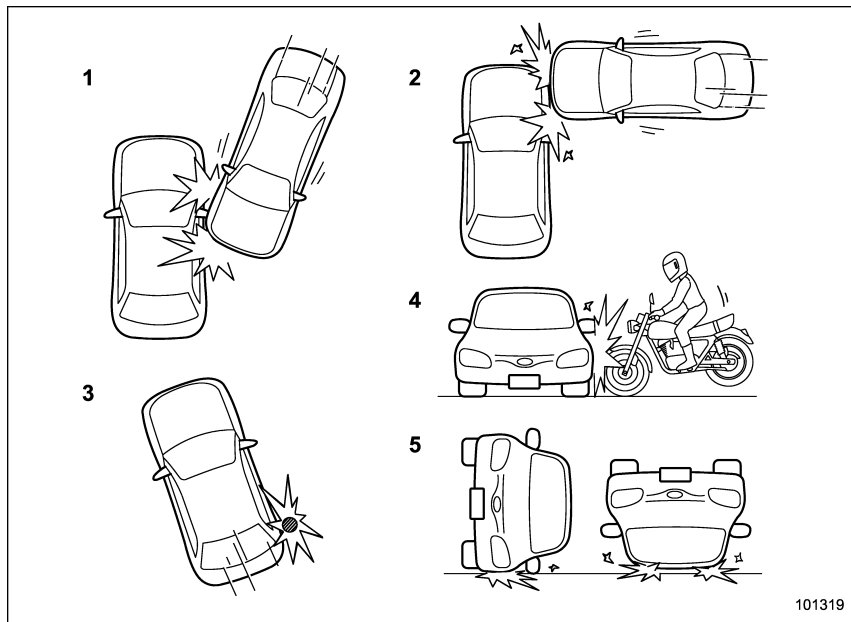

- 1) The vehicle is involved in an oblique side-on impact.
- 2) The vehicle is involved in a side-on impact in an area outside the vicinity of the passenger compartment.
- 3) The vehicle strikes a telephone pole or similar object.
- 4) The vehicle is involved in a side-on impact from a motorcycle.
- 5) The vehicle rolls onto its side or the roof.

There are many types of collisions which might not necessarily require SRS side airbag deployment. In the event of accidents like those illustrated, the SRS side airbag may not deploy depending on the level of accident forces involved.

▽ **Examples of the types of accidents in which the SRS curtain airbag is unlikely to deploy.**

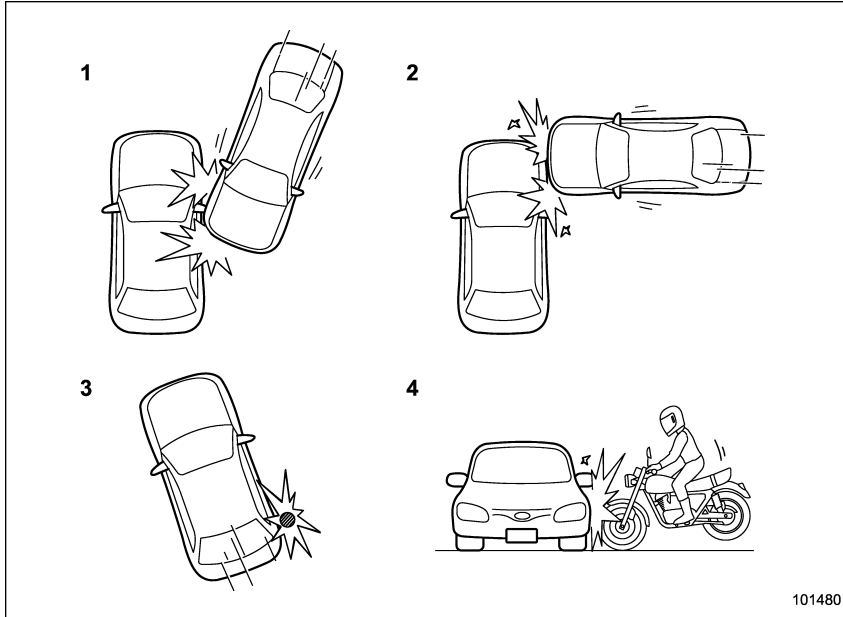

- 1) The vehicle is involved in an oblique side-on impact.
- 2) The vehicle is involved in a side-on impact in an area outside the vicinity of the passenger compartment.
- 3) The vehicle strikes a telephone pole or similar object.
- 4) The vehicle is involved in a side-on impact from a motorcycle.

There are many types of collisions which might not necessarily require SRS curtain airbag deployment. In the event of accidents like those illustrated, the SRS curtain airbag may not deploy depending on the level of accident forces involved.

▽ **Examples of the types of accidents in which the SRS side airbag and SRS curtain airbag are not designed to deploy in most cases**

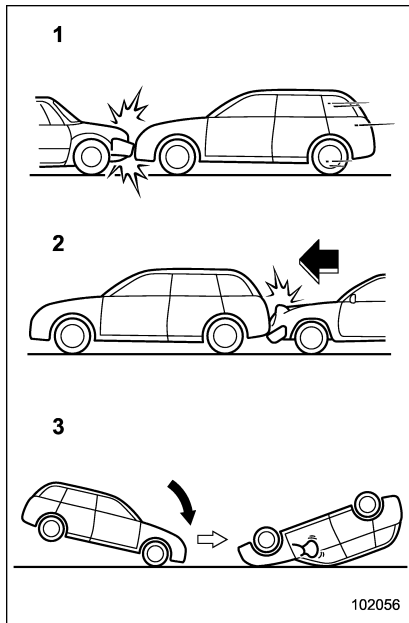

1) The vehicle is involved in frontal collision with another vehicle (moving or station-

- ary).
- 2) The vehicle is struck from behind.
- 3) The vehicle pitches end over end.

In the event of accidents like those illustrated, the SRS side airbag and SRS curtain airbag are not designed to deploy in most cases.

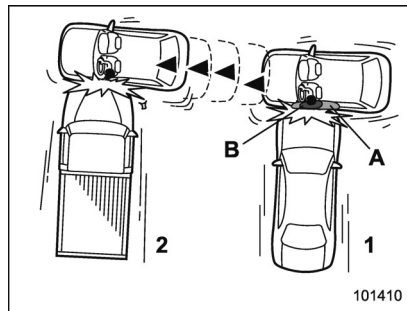

- 1) First impact
- 2) Second impact
- A) SRS curtain airbag
- B) SRS side airbag

In an accident where the vehicle is struck from the side more than once, the SRS side airbag and SRS curtain airbag deploy only once on the first impact.

Example: In the case of a double side impact collision, first with one vehicle and immediately followed by another from the

same direction, once the SRS side airbag and SRS curtain airbag are activated on the first impact, they will not be activated on the second.

■ SRS airbag system monitors

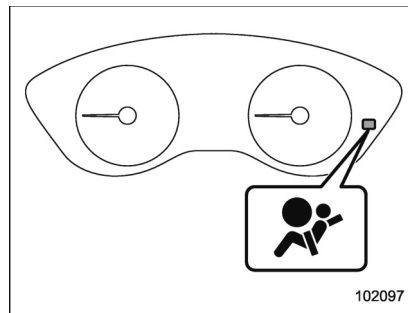

SRS airbag system warning light

A diagnostic system continually monitors the readiness of the SRS airbag system (including front seatbelt pretensioners) while the vehicle is being driven. The SRS airbag system warning light will show normal system operation by illuminating for approximately 6 seconds when the ignition switch is turned to the "ON" position.

The following components are monitored by the indicator:

- Front sub sensor
- Airbag control module (including impact sensor and rollover sensor)
- Frontal airbag module
 - Driver's side
 - Front passenger's side
- Knee airbag module (driver's side)
- Side airbag sensor
- Front door impact sensor
- Side airbag module
- Curtain airbag sensor
- Curtain airbag module
- Satellite safing sensor (under the rear center seat)
- Seatbelt pretensioner (driver's side)
- Seatbelt pretensioner and adaptive force limiter (front passenger's side)
- Lap belt pretensioner (front passenger's side)
- Seatbelt buckle switch (front passenger's side)
- Front passenger's occupant detection system sensor
- Front passenger's occupant detection control module
- Front passenger's frontal airbag ON and OFF indicator
- All related wiring



WARNING

If the warning light exhibits any of the following conditions, there may be a malfunction in the seatbelt pretensioners and/or SRS airbag system.

- Flashing or flickering of the warning light
- No illumination of the warning light when the ignition switch is first turned to the "ON" position
- Continuous illumination of the warning light
- Illumination of the warning light while driving

Immediately take your vehicle to your nearest SUBARU dealer to have the system checked. Unless checked and properly repaired, the seatbelt pretensioners and/or SRS airbag will not operate properly in the event of a collision, which may increase the risk of injury.

■ SRS airbag system servicing



WARNING

- When discarding an airbag module or scrapping the entire vehicle damaged by a collision, consult your SUBARU dealer.
- The SRS airbag has no user-serviceable parts. Do not use electrical test equipment on any circuit related to the SRS airbag system. For required servicing of the SRS airbag, consult your nearest SUBARU dealer. Tampering with or disconnecting the system's wiring could result in accidental inflation of the SRS airbag or could make the system inoperative, which may result in serious injury.



CAUTION

If you need service or repair in areas indicated in the following list, have the work performed by an authorized SUBARU dealer. The SRS airbag control module, impact sensors and airbag modules are stored in these areas.

- Under the center of the instrument panel
- On both the right and left sides at the front of the vehicle
- Steering wheel and column and nearby areas
- Bottom of the steering column and nearby areas
- Top of the dashboard on front passenger's side and nearby areas
- Each front seat and nearby area
- Inside each center pillar
- Inside each front door
- In each roof side (from the front pillar to a point over the rear seat)
- Between the rear seat cushion and rear wheel house on each side
- Under the rear center seat

In the event that the SRS airbag is deployed, replacement of the system should be performed only by an authorized SUBARU dealer. When the components of the SRS airbag system are replaced, use only genuine SUBARU parts.

NOTE

In the following cases, contact your SUBARU dealer as soon as possible.

- The front part of the vehicle was involved in an accident in which only the driver's SRS frontal airbag or both driver's and front passenger's SRS frontal airbags did not deploy.
- The pad of the steering wheel, the cover over the front passenger's SRS frontal airbag, or either roof side (from the front pillar to a point over the rear seat) is scratched, cracked, or otherwise damaged.
- The center pillar, front door, rear wheel house or rear sub frame, or an area near these parts, was involved in an accident in which the SRS side airbag and SRS curtain airbag did not deploy.
- The fabric or leather of either front seatback is cut, frayed, or otherwise damaged.
- The rear part of the vehicle was involved in an accident in which no SRS airbag was deployed.

■ Precautions against vehicle modification



WARNING

To avoid accidental activation of the system or rendering the system inoperative, which may result in serious injury, no modifications should be made to any components or wiring of the SRS airbag system.

This includes following modifications.

- Installation of custom steering wheels
- Attachment of additional trim materials to the dashboard
- Installation of custom seats
- Replacement of seat fabric or leather
- Installation of additional fabric or leather on the front seat
- Attachment of a hands-free microphone or any other accessory to a front pillar, a center pillar, a rear pillar, the windshield, a side window, an assist grip, or any other cabin surface that would be near a deploying SRS curtain airbag.

- Installation of additional electrical/electronic equipment such as a mobile two-way radio on or near the SRS airbag system components and/or wiring is not advisable. This could interfere with proper operation of the SRS airbag system.

 **CAUTION**

Do not perform any of the following modifications. Such modifications can interfere with proper operation of the SRS airbag system.

- Attachment of any equipment (bush bar, winches, snow plow, skid plate, etc.) other than genuine SUBARU accessory parts to the front end.
- Modification of the suspension system or front end structure.
- Installation of a tire of different size and construction from the tires specified on the vehicle placard attached to the driver's door pillar or specified for individual vehicle models in this Owner's Manual.
- Attachment of any equipment (side steps or side sill protectors,

etc.) other than genuine SUBARU accessory parts to the side body.

Always consult your SUBARU dealer if you want to install any accessory parts on your vehicle.

■ How to contact the vehicle manufacturer concerning modifications for persons with disabilities that may affect the advanced airbag system

Changing or moving any parts of the front seats, rear seat, seatbelts, front bumper, front side frame, radiator panel, instrument panel, combination meter, steering wheel, steering column, tire, suspension or floor panel can affect the operation of the SUBARU advanced airbag system. If you have any questions, you may contact the following SUBARU distributors.

<Continental U.S., Alaska and the District of Columbia>

Subaru of America, Inc.
Customer Dealer Services Department
P.O. Box 6000
Cherry Hill, NJ 08034-6000
1-800-SUBARU3 (1-800-782-2783)

<Hawaii>

Subaru Hawaii
2850 Pukoloa Street, Suite 202,
Honolulu, HI 96819-4467
808-839-2273

<Guam>

Shen's Corporation dba Prestige Automobile
491, East Marine Corps Drive, Route 1
Dededo, Guam 96921-6225
671-633-2698

<Puerto Rico>

Trebol Motors
P.O. Box 11204, San Juan, Puerto Rico
00910
787-793-2828

<Canada>

Subaru Canada, Inc.
Consumer Support Department
560 Suffolk Court, Mississauga, Ontario
L5R 4J7
1-800-894-4212

There are currently no SUBARU distributors in any other U.S. territories. If you are in such an area, please contact the SUBARU distributor or dealer from which you bought your vehicle.

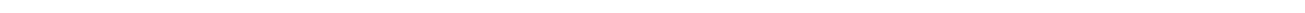
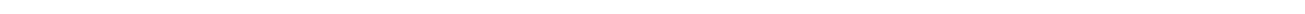
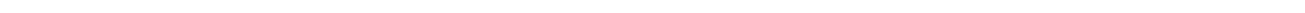
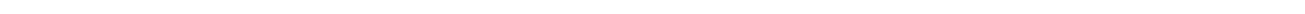
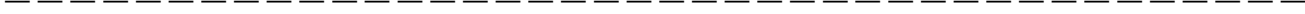
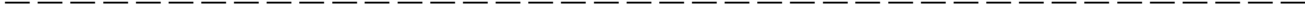
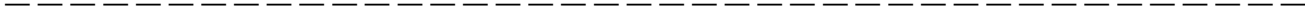
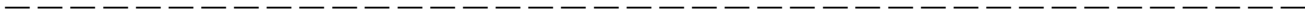
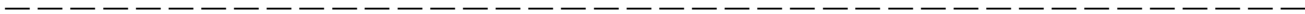
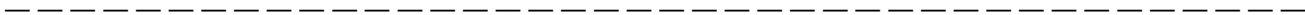

Keys	2-3	Selecting audible signal operation (models without “keyless access with push-button start system”)	2-21
Key number plate.....	2-3	Replacing the battery	2-22
Keyless access with push-button start system (if equipped)	2-3	Replacing lost transmitters	2-22
Safety precautions	2-4	Certification for remote keyless entry system	2-22
Locking and unlocking by holding the access key fob.....	2-8	Door locks	2-23
Unlock using PIN Code Access	2-12	Locking and unlocking from the outside.....	2-23
Power saving function.....	2-14	Locking and unlocking from the inside.....	2-24
Power saving function of access key fob	2-14	Key lock-in prevention function.....	2-25
Disabling keyless access function	2-14	Battery drainage prevention function.....	2-26
Selecting audible signal operation	2-16	Alarm system	2-26
Warning chimes and warning indicator	2-16	Alarm system operation.....	2-27
When access key fob does not operate properly	2-16	Arming the system	2-27
Replacing battery of access key fob	2-16	Disarming the system	2-28
Replacing access key fob.....	2-16	Alarm system setting.....	2-29
Certification for keyless access with push-button start system.....	2-16	If you have accidentally triggered the alarm system	2-29
Immobilizer	2-17	Valet mode	2-29
Security indicator light	2-18	Child safety locks	2-30
Key replacement	2-18	Windows	2-30
Certification for immobilizer system.....	2-18	Power window operation.....	2-30
Remote keyless entry system	2-19	Initialization of power window with one-touch auto up/down function	2-32
Locking the doors	2-21	Trunk lid (sedan)	2-33
Unlocking the doors	2-21	To open and close the trunk lid from outside.....	2-33
Opening the trunk lid (sedan)	2-21	To open the trunk lid from inside.....	2-33
Unlocking the rear gate (5-door models)	2-21	Internal trunk lid release handle	2-34
Vehicle finder function.....	2-21	Rear gate (5-door models)	2-35
Sounding a panic alarm.....	2-21	Lock/unlock.....	2-36
		Open/close	2-36

Keys and doors

Moonroof (if equipped)	2-37
 Moonroof switches	2-38

Sun shade	2-39
------------------------	-------------

Keys

NOTE

For models with “keyless access with push-button start system”, refer to “Keyless access with push-button start system” 2-3.

The following keys are provided with the vehicle.

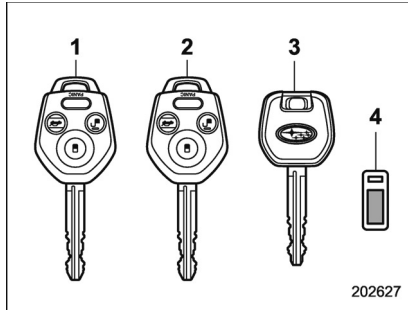

- 1) Master key (Main)
- 2) Master key (Sub)
- 3) Sub key
- 4) Key number plate

A key can be used in the following locations.

- Ignition switch
- Driver's door

- Glove box

NOTE

Locking/unlocking using the remote keyless entry system can also be controlled with the buttons on the key. For detailed information, refer to “Remote keyless entry system” 2-19.

CAUTION

Do not attach a large key holder or key case to either key. If it bangs against your knees while you are driving, it could turn the ignition switch from the “ON” position to the “ACC” or “LOCK” position, thereby stopping the engine.

■ Key number plate

The key number is stamped on the key number plate attached to the key set. Write down the key number and keep it in another safe place, not in the vehicle. This number is needed to make a replacement key if you lose your key or lock it inside the vehicle. Refer to “Key replacement” 2-18.

Keyless access with push-button start system (if equipped)

The following access key fobs are provided with the vehicle.

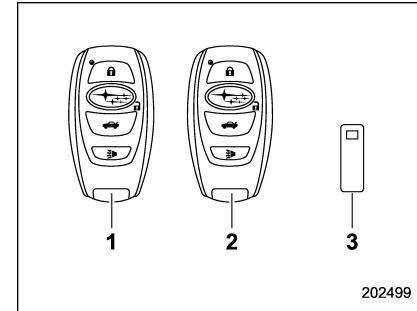

- 1) Access key fob (main)
- 2) Access key fob (sub)
- 3) Key number plate

The keyless access with push-button start system allows you to perform the following functions when you are carrying the access key fob.

- Locking and unlocking of the doors and rear gate (5-door models). Refer to “Locking and unlocking by holding the access key fob” 2-8.
- Opening the trunk (sedan). Refer to

“Locking and unlocking by holding the access key fob” 2-8.

- Starting and stopping the engine. For detailed information, refer to “Starting and stopping engine (models with push-button start system)” 7-12.

- Arming and disarming the alarm system. For detailed information, refer to “Alarm system” 2-26.

NOTE

- Locking/unlocking using the remote keyless entry system can also be controlled with the buttons on the access key fob. For detailed information, refer to “Remote keyless entry system” 2-19.

- Carefully store the key number plate supplied with the access key fob. It is necessary for vehicle repair and additional registration of access key fobs. For details, refer to “Key replacement” 2-18.

An emergency key is attached to each access key fob.

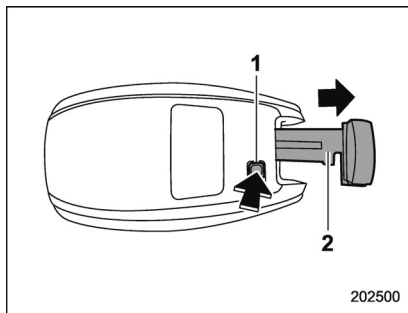

- 1) Release button
- 2) Emergency key

While pressing the release button of the access key fob, take out the emergency key.

The emergency key is used for the following operations.

- Locking and unlocking the driver's door
- Locking and unlocking the glove box

NOTE

The glove box can be kept locked when you leave your vehicle and the access key fob (with the emergency key removed) at a parking facility.

■ Safety precautions

⚠ WARNING

If you wear an implanted pacemaker or an implanted defibrillator, stay at least 8.7 in (22 cm) away from the transmitting antennas installed on the vehicle.

The radio waves from the transmitting antennas on the vehicle could adversely affect the operation of implanted pacemakers and implanted defibrillators.

If you wear electronic medical equipment other than an implanted pacemaker or an implanted defibrillator, before using the keyless access with push-button start system, refer to “Radio waves used for the keyless access with push-button start system” mentioned later, and contact the electronic medical equipment manufacturer for more information. The radio waves from the transmitting antennas on the vehicle could adversely affect the operation of the electronic medical equipment.

“Radio waves used for the keyless access with push-button start sys-

tem”

- The keyless access with push-button start system uses radio waves of the following frequency* in addition to the radio waves used for the remote keyless entry system. The radio waves are periodically output from the antennas installed on the vehicle as shown in the following illustrations.

* Radio frequency: 134 kHz

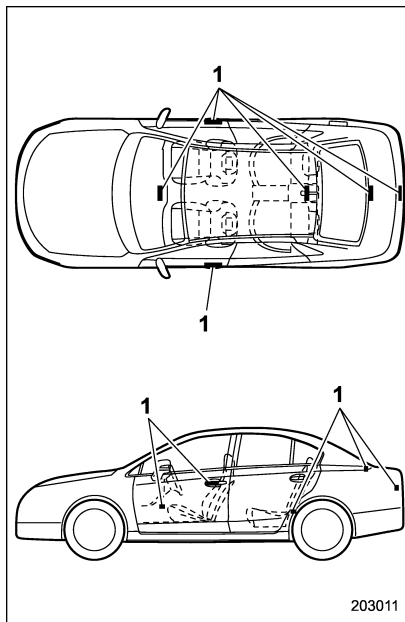

Sedan
1) Antenna

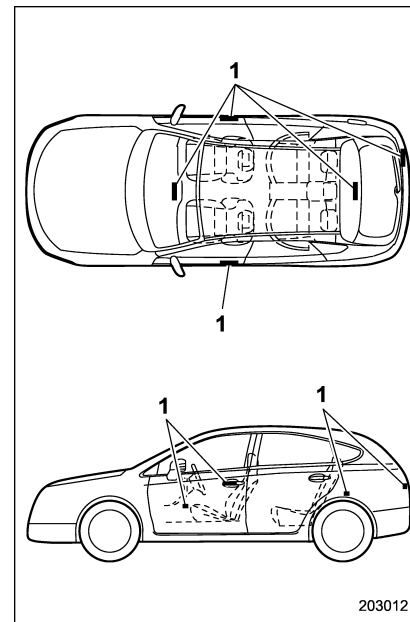

5-door models
1) Antenna

CAUTION

- Never leave or store the access key fob inside the vehicle or within 6.6 ft (2 m) around the vehicle (e.g., in the garage). The access key fob may be locked inside the vehicle, or the battery may discharge rapidly. Note that the push-button ignition switch may not turn on in some cases depending on the location of the access key fob.
- The access key fob contains electronic components. Observe the following precautions to prevent malfunctions.
 - Although you can replace the battery of the access key fob yourself, it is recommended that the battery be replaced by a SUBARU dealer to avoid the risk of damage at the time of replacement.
 - Do not get the access key fob wet. If the access key fob gets wet, wipe it off immediately and let it dry completely.
 - Do not apply strong impacts to the access key fob.
 - Keep the access key fob away

from magnetic sources.

- Never leave the access key fob in direct sunlight or anywhere that may become hot, such as on the dashboard. It may damage the battery or cause circuit malfunctions.
- Do not wash the access key fob in an ultrasonic washer.
- Do not leave the access key fob in humid or dusty locations. Doing so may cause malfunctions.
- Do not leave the access key fob near personal computers or home electric appliances. Doing so may cause the access key fob to malfunction, resulting in battery discharge.
- If the access key fob is dropped, the integrated emergency key inside may become loose. Be careful not to lose the emergency key.
- When you carry the access key fob on an airplane, do not press the button of the access key fob while in the airplane. When any button of the access key fob is pressed, radio waves are sent and may affect the operation of

the airplane. When you carry the access key fob in a bag on an airplane, take measures to prevent the buttons of the access key fob from being pressed.

NOTE

- The operational/non-operational setting for the keyless access function can be changed. For the setting procedure, refer to “Disabling keyless access function” 9-2-14.
- For detailed information about the operation method for the push-button ignition switch while the keyless access function is switched to the non-operational mode, refer to “Access key fob – if access key fob does not operate properly” 9-18.
- The keyless access with push-button start system uses weak radio waves. The status of the access key fob and environmental conditions may interfere with the communication between the access key fob and the vehicle under the following conditions, and it may not be possible to lock or unlock the doors or start the engine.
 - When operating near a facility where strong radio waves are transmitted, such as a broadcast station

and power transmission lines

- When products that transmit radio waves are used, such as an access key fob or a remote transmitter key of another vehicle
- When carrying the access key fob of your vehicle together with the access key fob or the remote transmitter of another vehicle
- When the access key fob is placed near wireless communication equipment such as a cell phone
- When the access key fob is placed near a metallic object
- When metallic accessories are attached to the access key fob
- When carrying the access key fob with electronic appliances such as a laptop computer
- When the battery of the access key fob is discharged
- The access key fob is always communicating with the vehicle and is continuously using the battery. Although the life of the battery varies depending on the operating conditions, it is approximately 1 to 2 years. If the battery becomes fully discharged, replace it with a new one.
- If an access key fob is lost, it is recommended that all of the remaining access key fobs be reregistered. For

reregistration of an access key fob, contact a SUBARU dealer.

- For a spare access key fob, contact a SUBARU dealer.
- Up to 7 access key fobs can be registered for one vehicle.
- Do not leave the access key fob in the storage spaces inside the vehicle, such as the door pocket, dashboard, inside the trunk and the corner of the cargo area. Vibrations may damage the key fob or turn on the switch, possibly resulting in a lockout.
- After the vehicle battery is discharged or replaced, initialization of the steering lock system may be required to start the engine. In this case, perform the following procedure to initialize the steering lock.

(1) Turn the push-button ignition switch to the "OFF" position. For details, refer to "Switching power status" 3-7.

(2) Open and close the driver's door.

(3) Wait for approximately 10 seconds.

When the steering is locked, the initialization is completed.

- Do not leave the access key fob in the following places.

- On the instrument panel
- On the floor
- Inside the glove box
- Inside the door trim pocket
- On the rear seat
- On the rear shelf (sedan)
- Inside the trunk (sedan)
- In the cargo area (5-door models)

If you do, the following situations may occur.

- The access key fob is mistakenly locked inside the vehicle.
- A false warning issues although no malfunction actually occurs.
- No warning issues even when any malfunction occurs.

■ Locking and unlocking by holding the access key fob

When the access key fob is carried within the operating range, the doors and the rear gate (5-door models) can be locked/unlocked just by touching the door handle.

NOTE

The vehicle can also be locked/unlocked with the remote keyless entry system. For details, refer to “Remote keyless entry system” 2-19.

▼ Operating ranges

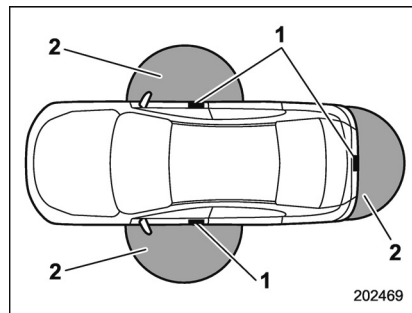

Sedan

- 1) Antenna
- 2) Operating range (approximately 16 to 32 in (40 to 80 cm))

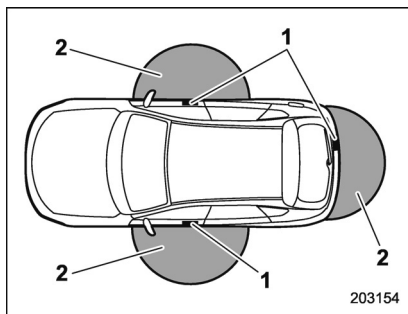

5-door models

- 1) Antenna
- 2) Operating range (approximately 16 to 32 in (40 to 80 cm))

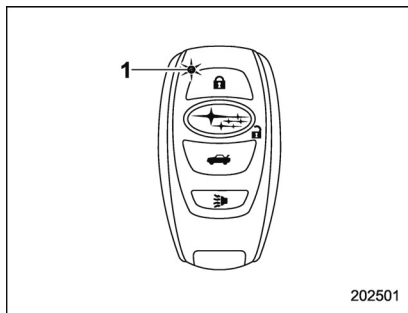

- 1) LED indicator

When the access key fob is within either of

the operating ranges of the front doors, the LED indicator on the access key fob flashes. When the keyless access functions are disabled, the LED indicator does not flash unless a button on the access key fob is pressed.

NOTE

- If the access key fob is placed too close to the vehicle body, the keyless access functions may not operate properly. If they do not operate properly, repeat the operation from further away.
- If the access key fob is placed near the ground or in an elevated location from the ground, even if it is in the indicated operating range, the keyless access function may not operate properly.
- When the access key fob is within the operating range, it is possible for anyone, even someone who is not carrying the access key fob, to operate the keyless access function. Note that the keyless access function can be operated only by the door handle, door lock sensor, rear gate opener button, trunk opener button or rear lock button in the operating range in which the access key fob is detected.
- It is not possible to lock the doors and rear gate using the keyless access

function when the access key fob is inside the vehicle. However, depending on the status of the access key fob and the environmental conditions, the access key fob may be locked inside the vehicle. Before locking the vehicle, make sure that you have the access key fob.

- When the battery of the access key fob is discharged, or when operating it in a location with strong radio waves or noise (e.g., near a radio tower, power plant, broadcast station or an area where wireless equipment is used), or while talking on a cell phone, the operating ranges may be reduced, or the keyless access function may not operate.

In such a case, perform the procedure described in “Locking and unlocking” [☞9-18](#).

- The doors may lock or unlock when the car is being washed or exposed to a significant amount of water that contacts the door handle while the key fob is still in the operating range.

▼ How to lock and unlock

It is possible to perform the following operations when you are carrying the access key fob.

- Lock and unlock the doors

- Unlock the trunk lid (sedan)
- Unlock and lock rear gate (5-door models)

NOTE

- The trunk can be opened without the access key fob if all doors are unlocked. When you begin driving the vehicle, the trunk lid will lock automatically.

- It is not possible to lock the doors and rear gate using the keyless access function when the push-button ignition switch is in the “ACC” or “ON” position. Refer to “Switching power status” [☞3-7](#).

- If the door handle is gripped with a gloved hand, the door lock may not be released.

- If the door lock sensor is touched three times or more repeatedly, the system will ignore the sensor operation.

- When performing the locking procedure too quickly, locking may not have been completed. After performing the locking procedure, it is recommended to pull the REAR door handle to confirm that the doors have been locked.

- If any of the doors (or the rear gate/trunk lid) are not fully closed, the following will occur to alert you that

the doors (or the rear gate/trunk lid) are not properly closed.

- an electronic chirp sounds five times.
- the hazard warning flashers flash five times.

- It is possible to lock the doors even when one of the doors is open. After performing the locking procedure, close the opened door or rear gate (5-door models) to lock it.

- Within 3 seconds after locking the doors and the rear gate by using the keyless access function, it is not possible to unlock doors and/or the rear gate (5-door models) by using the keyless access function.

- When locking, be sure to carry the access key fob to prevent locking the access key fob in the vehicle.

- The setting of the hazard warning flasher operation and the volume of the audible signal can be changed by your SUBARU dealer. Contact your SUBARU dealer for details. Also, for models with the combination meter display (color LCD), the setting of the hazard warning flasher operation can be changed by operating the combination meter display (color LCD). For details, refer to “Keyless Entry System” [☞3-43](#).

▽ Locking with the door lock sensor

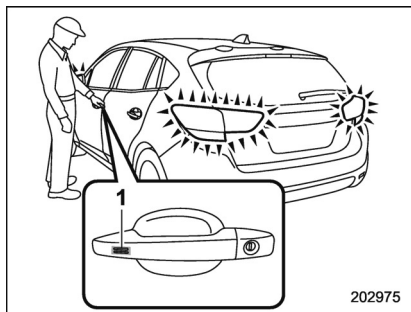

1) Door lock sensor

Carry the access key fob, close all doors including the rear gate (5-door models), and touch the door lock sensor on the door handle. All doors including the rear gate will be locked. Also, an electronic chirp will sound once and the hazard warning flashers will flash once.

▽ Locking with the rear lock button (5-door models)

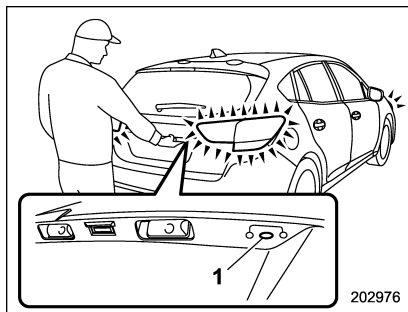

1) Rear lock button

Carry the access key fob, close all doors including the rear gate and press the rear lock button. The rear gate and all doors will be locked. Also, an electronic chirp will sound once and the hazard warning flashers will flash once.

▽ Unlocking

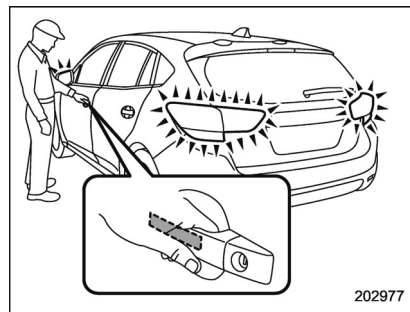

Carry the access key fob, and grip the following door handle.

- The driver's door handle:
Either only the driver's door will unlock, or all doors will unlock.
- The front passenger's door handle:
All doors and rear gate (5-door models) will be unlocked.

Also, an electronic chirp will sound twice and the hazard warning flashers will flash twice.

▽ Opening rear gate (5-door models)

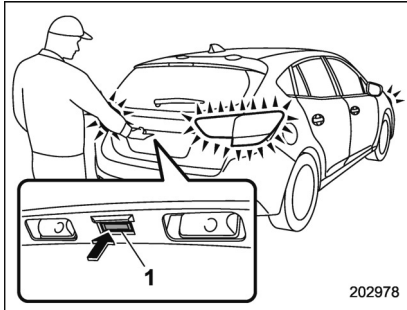

1) Rear gate opener button

Carry the access key fob, and press the rear gate opener button. Either only the rear gate will unlock, or all doors will unlock. Also, an electronic chirp will sound twice and the hazard warning flashers will flash twice.

▽ Opening trunk (sedan)

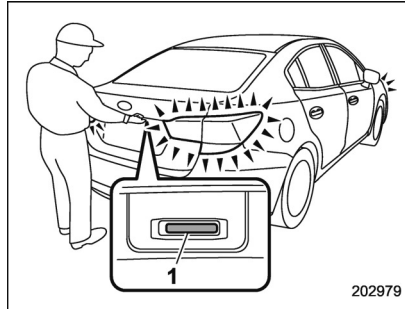

1) Trunk opener button

Carry the access key fob, and press the trunk opener button. The trunk will open. An electronic chirp will sound twice and the hazard warning flashers will flash twice.

NOTE

Under the following conditions, the trunk can be opened without the key fob.

- the trunk lock/unlock setting is set to on
- all doors are unlocked

The trunk lock/unlock setting can be changed by a SUBARU dealer. Contact your SUBARU dealer to change the

setting.

▼ Door unlock selection function

When the door is unlocked using the keyless access function, only the doors that were set can be unlocked.

The settings can be changed with the following methods.

- The setting can be changed by operating the combination meter display (color LCD) (if equipped). Refer to "Keyless Entry System" 3-43.
- The setting can be changed by a SUBARU dealer.

■ Unlock using PIN Code Access

When all doors including the rear gate (5-door models) are locked, you can unlock the doors (including rear gate) without a key by performing the following procedure.

- Sedan: press the trunk opener button
- 5-door models: press the rear lock button

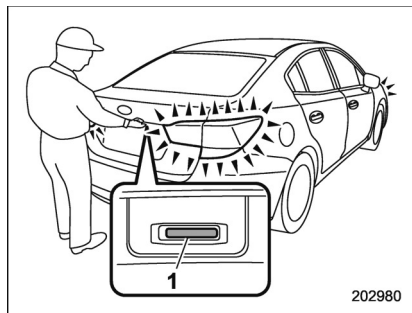

1) Trunk opener button (sedan)

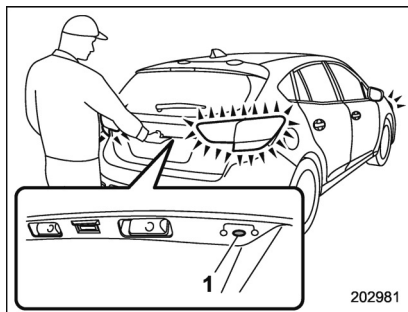





1) Rear lock button (5-door models)



NOTE

PIN Code Access will be helpful if the key fob is accidentally left in the vehicle. It is recommended that a 5-digit security code (PIN code) be registered.

▼ Preparation for registering a PIN code

1. Turn off the ignition switch.
 2. Close all doors (including trunk/rear gate).
 3. Press and hold the “” button on the access key fob. Then all doors (including rear gate) will be locked.
 4. Keep the “” button pressed, and press the trunk opener button (sedan)/rear lock button (5-door models) within 5 seconds after step 3.
 5. Press and hold the trunk opener button (sedan)/rear lock button (5-door models) for more than 5 seconds. Confirm a chirp sound.
 6. Release the “” button and trunk opener button (sedan)/rear lock button (5-door models).
 7. Press the “” button on the access key fob while the chirp sounds.
- Then the chirp will stop and the preparation is complete.

NOTE

Press the “” button within 30 seconds of step 6 to end the preparation mode and move on to the registration stage. Unless the “” button is pressed within 30 seconds after step 6, the PIN code

registration will be canceled.

▼ Registration for a PIN code

For example, to register “32468” as the PIN code, perform the following procedure.

1. Press the trunk opener button (sedan)/rear lock button (5-door models) three times.
2. After a chirp sounds once, press the trunk opener button (sedan)/rear lock button (5-door models) twice.
3. After a chirp sounds once, press the trunk opener button (sedan)/rear lock button (5-door models) four times.
4. After a chirp (ding) sounds once, press the trunk opener button (sedan)/rear lock button (5-door models) six times.
5. After a chirp (ding) sounds once, press the trunk opener button (sedan)/rear lock button (5-door models) eight times.
6. Perform steps 1 to 5 again within approximately 30 seconds after the chirp starts sounding intermittently.
7. All doors will be unlocked and locked. Then the PIN code will be registered.

NOTE

- Press the trunk opener button (sedan)/rear lock button (5-door models) ten times to enter “0”.
- Change the PIN code frequently to protect your vehicle from theft.
- If you have lent your vehicle to another person, confirm that the PIN code has not been changed or deleted. If the PIN code has been changed or deleted, reregister a new PIN code.
- If you make an error during the registration procedure, press the “

make sure that you can unlock the doors using the PIN code.

- The PIN code cannot be deleted while the keyless access function is disabled by operating the access key fob.
- Reregister the PIN code in the following case.
 - when you forget the PIN code
 - when you want to change the PIN code

▼ Unlocking

Perform steps 1 to 5 described in “Registration for a PIN code”.

NOTE

- You cannot unlock by PIN Code Access in the following cases.
 - when the access key fob is within the operating ranges
 - when the ignition switch is in the “ACC” or “ON” position
- If you make an operation error during the unlocking procedure, start over with the unlocking procedure after waiting for 5 seconds or longer.
- To protect your vehicle from theft, a buzzer will sound if incorrect PIN codes are entered five times continuously. If this occurs, you cannot unlock the doors by PIN Code Access for 5

minutes.

■ Power saving function

The keyless access function will be disabled in the following cases to protect the access key fob battery and the vehicle battery.

- **Case 1:** When the keyless access function and the remote keyless entry system have not been used for 2 weeks or longer while all doors are locked

Operate one of the following items to recover the keyless access function:

- Unlock the doors by operating any procedure other than gripping the front passenger's door handle
- Lock the doors
- Open a door and then close it

- **Case 2:** When the access key fob has been left in the operating range for 10 minutes or longer while all doors are locked



Operate one of the following items to recover the keyless access function:

- Unlock the doors by gripping the door handle
- Unlock the doors by pressing the rear gate opener button
- Lock the doors by touching the door lock sensor

- Lock or unlock the doors by using the remote keyless entry system
- Lock or unlock the doors by using the power door locking switch
- Open either of the front doors

■ Power saving function of access key fob

This function stops the access key fob from receiving signals and helps minimize the battery consumption of the access key fob.

1. Press the “” button twice while holding the “” button.

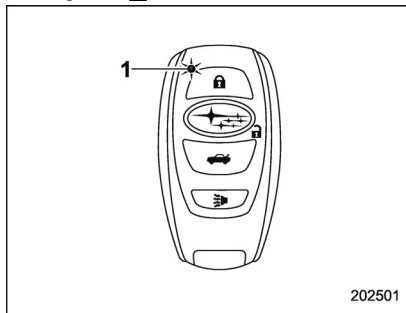

1) LED indicator



2. Confirm that the LED indicator blinks 4 times to notify that the setting is complete. When the access key fob is in the power

save mode, the keyless access function and push-button start system will not be available.

To cancel the power save mode, press one of the buttons on the access key fob.

■ Disabling keyless access function

WARNING

If you wear an implanted pacemaker or an implanted defibrillator, perform the procedure described in “By operating the driver’s door”  2-15 to disable the keyless access function. If you perform the procedure described in “By operating the access key fob”  2-15, the operation of an implanted pacemaker or implanted defibrillator may be affected by the radio waves from the transmitter antenna.

When the vehicle is not going to be used for a long time, or when you choose not to use the keyless access function, the keyless access function can be disabled.

NOTE

- The locking and unlocking function by the remote keyless entry system is

not disabled.

- To start the engine while the functions are disabled, perform the procedure described in “Starting engine” 9-19.

▼ **Disabling functions**

▽ **By operating the access key fob**

If you have registered a PIN code for PIN Code Access, you can disable the keyless access function by operating the access key fob. For details about registering a PIN code, refer to “Preparation for registering a PIN code” 2-12.

1. Open the driver’s door.
2. Rotate the lock lever toward the lock position.

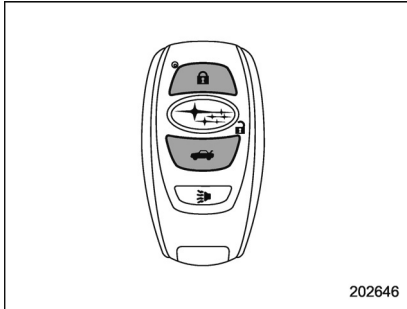

3. Press and hold the “” button and

“” button on the access key fob simultaneously for more than 5 seconds.

A chirp sound will be heard, and the function will be disabled.

▽ **By operating the driver’s door**

1. Sit in the driver’s seat, and close the door (5-door models).

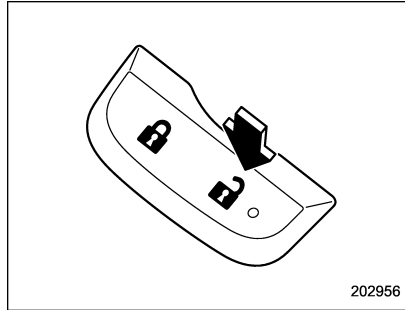

2. Push the unlock side of the power door locking switch.
3. Within 5 seconds after step 2 is performed, open the driver’s door.
4. Within 5 seconds after step 3 is performed, push the unlock side of the power door locking switch twice while the door is open.
5. Within 10 seconds after step 4 is performed, close and open the driver’s

door twice.

6. Within 10 seconds after step 5 is performed, push the unlock side of the power door locking switch twice while the door is open.
7. Within 10 seconds after step 6 is performed, close and open the driver’s door once.
8. Within 5 seconds after step 7 is performed, close the door.

A chirp sound will be heard, and the functions will be disabled.

NOTE

In steps 4 and 6, press the power door locking switch slowly. If the switch is pressed quickly, the functions may not be disabled.

▼ **Enabling functions**

When the procedure to disable the functions is performed again, a chirp sound will be heard, and the functions are enabled.

NOTE

- **The keyless access function will be enabled only if you perform the procedure in the same manner you disabled the function (for example, when disabling by operating the driver’s door, the function will not be enabled even if you operate the access key fob).**

- Press the push-button ignition switch if you do not know the procedure in which the keyless access function was disabled.

- When disabling by operating the driver's door: a chirp will not be heard
- When disabling by operating the access key fob: a chirp will be heard

■ Selecting audible signal operation

Using an electronic chirp, the system will give you an audible signal when the doors lock and unlock. If desired, you may turn the audible signal off. For more details, contact a SUBARU dealer.

NOTE

For models with the combination meter display (color LCD), the setting can be changed by operating the combination meter display (color LCD). For details, refer to "Vehicle Setting" 3-43.

■ Warning chimes and warning indicator

The keyless access with push-button start system sounds a warning chime and flashes the access key warning indicator on the combination meter in order to

minimize improper operations and help protect your vehicle from theft.

For details, refer to "Warning chimes and warning indicator of the keyless access with push-button start system" 3-25.

■ When access key fob does not operate properly

Refer to "Access key fob – if access key fob does not operate properly" 9-18.

■ Replacing battery of access key fob

Refer to "Replacing battery of access key fob" 11-45.

■ Replacing access key fob

Access key fobs can be replaced at SUBARU dealers. For more details, contact a SUBARU dealer.

■ Certification for keyless access with push-button start system

● U.S.-spec. models

FCC ID: HYQ14AHK

FCC ID: Y8PFJ16-1

FCC ID: Y8PSSPIMB02



CAUTION

FCC WARNING

Changes or modifications not expressly approved by the party responsible for compliance could void the user's authority to operate the equipment.

NOTE

This device complies with part 15 of the FCC Rules. Operation is subject to the following two conditions: (1) This device may not cause harmful interference, and (2) this device must accept any interference received, including interference that may cause undesired operation.

- Canada-spec. models

NOTE

This device complies with Industry Canada's licence-exempt RSSs. Operation is subject to the following two conditions: (1) This device may not cause interference; and (2) This device must accept any interference, including interference that may cause undesired operation of the device.

REMARQUE

Le présent appareil est conforme aux CNR d'Industrie Canada applicables aux appareils radio exempts de licence. L'exploitation est autorisée aux deux conditions suivantes: (1) l'appareil ne doit pas produire de brouillage; (2) l'utilisateur de l'appareil doit accepter tout brouillage radioélectrique subi, même si le brouillage est susceptible d'en compromettre le fonctionnement.

- Mexico-spec. models

Este equipo opera a título secundario, consecuentemente, debe aceptar interferencias perjudiciales incluyendo equipos de la misma clase y puede no causar interferencias a sistemas operando a título primario.

500612

IFT
RLVDE1415-1661
14AHK
DENSO

Immobilizer

The immobilizer system is designed to prevent an unauthorized person from starting the engine. Only keys registered with your vehicle's immobilizer system can be used to operate your vehicle. If engine start is attempted with an unregistered access key fob or key, the engine will not start. Even if the engine does start, it will stop after a few seconds. This system, however, is not a 100% anti-theft guarantee.



CAUTION

- Do not place the key under direct sunlight or anywhere it may become hot.
- Do not get the key wet. If the key gets wet, wipe it dry with a cloth immediately.
- Do not modify or remove the system. If modified or removed, the proper operation of the system cannot be guaranteed.

NOTE

- To protect your vehicle from theft, please pay close attention to the following security precautions:
 - Never leave your vehicle unattended with its keys inside.
 - Before leaving your vehicle, close all windows and the moonroof, and lock the doors, trunk (sedan) and rear gate (5-door models).
 - Do not leave spare keys or any record of your key number in the vehicle.
- The vehicle has a maintenance-free type immobilizer system.

■ Security indicator light

Refer to “Security indicator light” ☞3-30.

■ Key replacement

Your key number plate will be required if you ever need a replacement key made. Any new key must be registered for use with your vehicle’s immobilizer system before it can be used. The maximum number of keys that can be registered for use with one vehicle is as follows.

- Four (models without “keyless access with push-button start system”)
- Seven (models with “keyless access

with push-button start system”)

One key that has already been registered is required in order to register a new key.

NOTE

If you lose a key, the lost key’s ID code still remains in the memory of the vehicle’s immobilizer system. For security reasons, the lost key’s ID code should be erased from the memory. To erase the lost key’s ID code, all keys that will be used are required.

For details about new key registration and erasing the lost key’s ID code, contact your SUBARU dealer.

■ Certification for immobilizer system

- For models with “keyless access with push-button start system”:

Refer to “Certification for keyless access with push-button start system” ☞2-16.

- For models without “keyless access with push-button start system”:
 - U.S.-spec. models

FCC ID: Y8PFJ16-2



CAUTION

FCC WARNING

Changes or modifications not expressly approved by the party responsible for compliance could void the user’s authority to operate the equipment.

NOTE

This device complies with part 15 of the FCC Rules. Operation is subject to the following two conditions: (1) This device may not cause harmful interference, and (2) this device must accept any interference received, including interference that may cause undesired operation.

- Canada-spec. models

NOTE

This device complies with Industry Canada's licence-exempt RSSs. Operation is subject to the following two conditions: (1) This device may not cause interference; and (2) This device must accept any interference, including interference that may cause undesired operation of the device.

REMARQUE

Le présent appareil est conforme aux CNR d'Industrie Canada applicables aux appareils radio exempts de licence. L'exploitation est autorisée aux deux conditions suivantes: (1) l'appareil ne doit pas produire de brouillage; (2) l'utilisateur de l'appareil doit accepter tout brouillage radioélectrique subi, même si le brouillage est susceptible d'en compromettre le fonctionnement.

- Mexico-spec. models

Este equipo opera a título secundario, consecuentemente, debe aceptar interferencias perjudiciales incluyendo equipos de la misma clase y puede no causar interferencias a sistemas operando a título primario.

500612

Remote keyless entry system



CAUTION

- Do not expose the remote transmitter to severe shocks, such as those experienced as a result of dropping or throwing.
- Do not take the remote transmitter apart except when replacing the battery.
- Do not get the remote transmitter wet. If it gets wet, wipe it dry with a cloth immediately.
- When you carry the remote transmitter on an airplane, do not press the button of the remote transmitter while in the airplane. When any button of the remote transmitter is pressed, radio waves are sent and may affect the operation of the airplane. When you carry the remote transmitter in a bag on an airplane, take measures to prevent the buttons of the remote transmitter from being pressed.

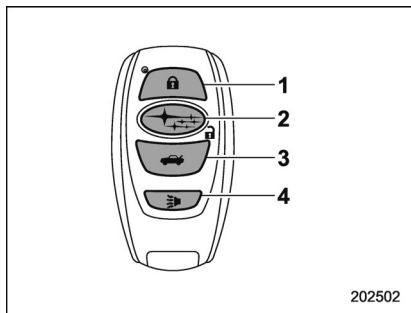

Access key fob

- 1) Lock/arm button
- 2) Unlock/disarm button
- 3) Trunk lid opener/rear gate unlock button
- 4) PANIC button

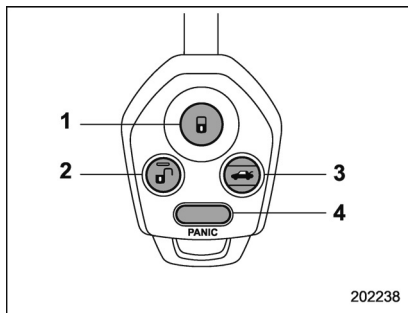

Transmitter

- 1) Lock/arm button
- 2) Unlock/disarm button
- 3) Trunk lid opener/rear gate unlock button
- 4) PANIC button

The remote keyless entry system has the following functions.

- Locking and unlocking the doors (and rear gate for 5-door models)
- Unlocking the trunk lid (sedan) or rear gate (5-door models)
- Sounding a panic alarm
- Arming and disarming the alarm system. For detailed information, refer to "Alarm system" 2-26.

The operable distance of the remote keyless entry system is approximately 30 feet (10 meters). However, this distance

will vary depending on environmental conditions. The system's operable distance will be shorter in areas near a facility or electronic equipment emitting strong radio waves such as a power plant, broadcast station, TV tower, or remote controller of home electronic appliances.

NOTE

- For models with "keyless access with push-button start system", the remote keyless entry system will not be activated when the push-button ignition switch is in any position other than the "OFF" position.
- For models without "keyless access with push-button start system", the remote keyless entry system will not be activated when the key is inserted in the ignition switch.
- The hazard warning flashers will flash once or twice when the access key fob/transmitter button is pressed in the following cases.
 - When locking the doors
 - When unlocking the doors
 - When opening the trunk lid (sedan)
 - When unlocking the rear gate (5-door models)

Operation of the hazard warning

flashers in the above cases can be set to “On” or “Off” by a SUBARU dealer. Consult your SUBARU dealer for details.

■ Locking the doors

Press the lock/arm button to lock all doors and rear gate (5-door models). An electronic chirp will sound once and the hazard warning flashers will flash once.

If any of the doors (or the rear gate/trunk lid) are not fully closed, the following will occur to alert you that the doors (or the rear gate/trunk lid) are not properly closed.

- an electronic chirp sounds five times.
- the hazard warning flashers flash five times.

When you close the door, it will automatically lock and then the following will occur.

- an electronic chirp sounds once.
- the hazard warning flashers flash once.

■ Unlocking the doors

Press the unlock/disarm button to unlock the driver's door. An electronic chirp will sound twice and the hazard warning flashers will flash twice. To unlock all doors and the rear gate (5-door models), briefly press the unlock/disarm button a

second time within 5 seconds.

NOTE

If the interval between the first and second presses of the unlock/disarm button (for unlocking of all of the doors and the rear gate) is extremely short, the system may not respond.

■ Opening the trunk lid (sedan)

Press and hold the trunk lid opener button to open the trunk lid. An electronic chirp will sound twice and the hazard warning flashers will flash twice.

■ Unlocking the rear gate (5-door models)

Press the rear gate unlock button to unlock the rear gate.

An electronic chirp will sound twice and the hazard warning flashers will flash twice.

■ Vehicle finder function

Use this function to find your vehicle parked among many vehicles in a large parking lot. Provided you are within 30 feet (10 meters) of the vehicle, pressing the lock/arm button three times in a 5-second period will cause your vehicle's horn to

sound once and its hazard warning flashers to flash three times.

NOTE

If the interval between presses is too short when you press the lock/arm button three times, the system may not respond to the signals from the remote transmitter.

■ Sounding a panic alarm

To activate the alarm, press the “PANIC” button once.

The horn will sound and the hazard warning flashers will flash.

To deactivate the panic alarm, press any button on the remote transmitter. Unless a button on the remote transmitter is pressed, the alarm will be deactivated after approximately 30 seconds.

■ Selecting audible signal operation (models without “keyless access with push-button start system”)

Using an electronic chirp, the system will give you an audible signal when the doors lock and unlock. If desired, you may turn the audible signal off.

Perform the following steps to deactivate

the audible signal. You can also use the same steps to restore the function.

1. Sit in the driver's seat and shut all doors and the rear gate (5-door models).

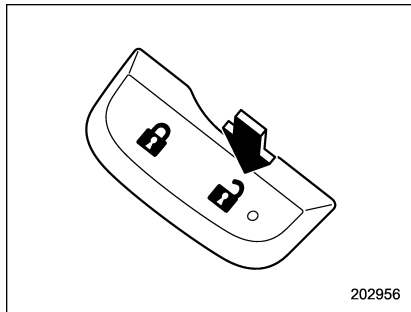

2. Hold down the unlock side of the power door locking switch.

3. While holding down the unlock side of the power door locking switch, pull the key out and re-insert it into the ignition switch at least 6 times within 10 seconds after Step 2.

4. Open and close the driver's door once within 10 seconds after Step 3.

5. The hazard warning flashers flash 3 times to indicate completion of the setting.

Your SUBARU dealer can perform the above procedure for you. Also, for models with a combination meter display (color

LCD), the setting can be changed using the display. For details, refer to "Vehicle Setting" 3-43.

■ Replacing the battery

Refer to "Replacing key battery" 11-45.

■ Replacing lost transmitters

If you lose a transmitter or want to purchase additional transmitters (up to four can be programmed), your transmitters should be reprogrammed for security reasons. For details, contact your SUBARU dealer and have the transmitters programmed into the remote keyless entry system.

■ Certification for remote keyless entry system

▼ U.S.-spec. models

⚠ CAUTION

FCC WARNING

Changes or modifications not expressly approved by the party responsible for compliance could void the user's authority to operate the equipment.

NOTE

This device complies with part 15 of the FCC Rules. Operation is subject to the following two conditions: (1) This device may not cause harmful interference, and (2) this device must accept any interference received, including interference that may cause undesired operation.

▼ Canada-spec. models

NOTE

This device complies with Industry Canada's licence-exempt RSSs. Operation is subject to the following two conditions: (1) This device may not cause interference; and (2) This device must accept any interference, including interference that may cause undesired operation of the device.

REMARQUE

Le présent appareil est conforme aux CNR d'Industrie Canada applicables aux appareils radio exempts de licence. L'exploitation est autorisée aux deux conditions suivantes: (1) l'appareil ne doit pas produire de brouillage; (2) l'utilisateur de l'appareil doit accepter tout brouillage radioélectrique subi, même si le brouillage est susceptible d'en compromettre le fonctionnement.

▼ Mexico-spec. models

La operación de este equipo está sujeta a las siguientes dos condiciones:

- (1) es posible que este equipo o dispositivo no cause interferencia perjudicial y
- (2) este equipo o dispositivo debe aceptar cualquier interferencia, incluyendo la que pueda causar su operación no deseada.

202642

IFETEL RLVSUTB15-1814
SUBARU
MODEL: TB1G077

IFETEL RLVSUTD15-1815
SUBARU
MODEL: TD1G049

Door locks

■ Locking and unlocking from the outside

NOTE

If you unlock the driver's door with a key (including an emergency key) and open the door while the alarm system is armed, the alarm system is triggered and the vehicle's horn sounds. In this case, perform any of the following operations:

- Models with "keyless access with push-button start system":
 - Press any button on the access key fob (except when the access key fob battery is discharged).
 - Press the push-button ignition switch to "ACC".
 - Carry the access key fob and perform either of the following procedures.
 - Grip the front door handle
 - Press the rear gate opener button
- Models without "keyless access with push-button start system":
 - Press any button on the remote transmitter (except when the transmitter battery is discharged).

- Insert the key into the ignition switch and turn the ignition switch to "ON".

For details about the alarm system, refer to "Alarm system" 2-26.

▼ How to lock and unlock the vehicle by using the key

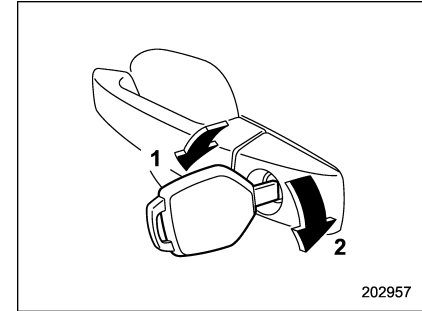

- 1) Rotate the key toward the front to lock.
- 2) Rotate the key toward the rear to unlock.

In this case, only the driver's side door is locked.

NOTE

Models with "keyless access with push-button start system":

The emergency key is directional. If the key cannot be inserted, change the

direction that the grooved side is facing and insert it again.

▼ How to lock the vehicle without using the key

To lock the door from outside without the key, the following methods are available.

▽ Locking using lock lever

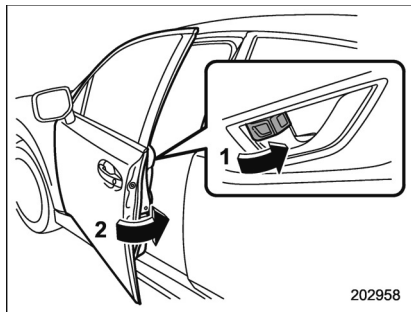

- 1) Rotate the lock lever forward.
- 2) Close the door.

In this way, only the door that was operated will be unlocked.

▽ Locking using power door locking switch

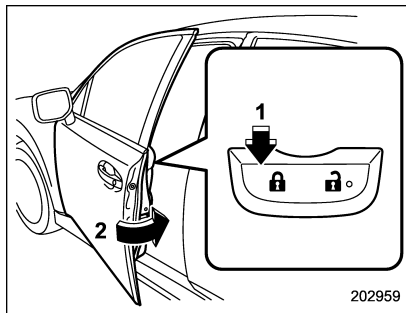

- 1) Press the lock side of the power door locking switch.*
- 2) Close the door.

*: For details about the power door locking switch, refer to "How to operate the power door locking switches" 2-25.

In this case, all closed doors and the rear gate (5-door models) are locked at the same time.

NOTE

Make sure that you do not leave the key inside the vehicle when locking the doors from the outside without the key.

■ Locking and unlocking from the inside

▼ How to use the lock lever

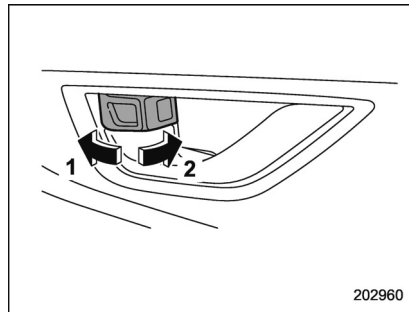

- 1) Rotate the lock lever rearward to unlock.
- 2) Rotate the lock lever forward to lock.

Always make sure that all doors and the rear gate (5-door models) are closed before starting to drive.

The red mark on the lock lever appears when the door is unlocked.

WARNING

Keep all doors locked when you drive, especially when small children are in your vehicle.

Along with the proper use of seat-

belts and child restraints, locking the doors reduces the chance of being thrown out of the vehicle in an accident.

It also helps prevent passengers from falling out if a door is accidentally opened, and intruders from unexpectedly opening doors and entering your vehicle.

▼ How to operate the power door locking switches

All doors and the rear gate (for 5-door models) can be locked and unlocked using the power door locking switches located at the driver's side and the front passenger's side doors.

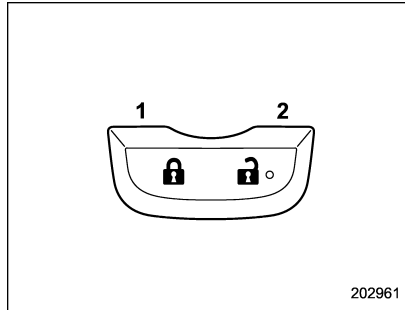

Example

- 1) Press to lock
- 2) Press to unlock

NOTE

Make sure that you do not leave the key inside the vehicle before locking the doors from the outside using the power door locking switches.

■ Key lock-in prevention function

This function prevents the doors from being locked under the following conditions.

- The key is still in the ignition switch (models without "keyless access with push-button start system")

- The ignition switch is in the "ON" position (models with "keyless access with push-button start system")
- With the driver's door open, the doors are automatically kept unlocked even if the power door locking switch is pressed to the lock position.

NOTE

- **When leaving the vehicle, make sure you are holding the key before locking the doors.**
- **The factory setting (default setting) for this function is set as "operational". This function's operational/non-operational setting can be changed by a SUBARU dealer. Contact a SUBARU dealer for details.**

▼ Non-operation of key lock-in prevention function

When the system is set so that it does not operate, the doors are locked by the following operation.

- If the lock lever is turned to the front ("LOCK") position with the driver's door open and the driver's door is then closed with the lock lever in that position, the driver's door is locked.
- If the spare key is used to lock the driver's door from the outside of the vehicle, the door is locked.

■ Battery drainage prevention function

If a door or the rear gate (5-door models) is not completely closed, the interior lights will remain illuminated as a result. However, several lights are automatically turned off by the battery drainage prevention function to prevent the battery from discharging. The following interior lights are affected by this function.

Item	Switch position	Automatically turning off
Map lights	DOOR	Approximately 20 minutes later
Dome light	DOOR	Approximately 20 minutes later
Ignition switch light	—	Approximately 20 minutes later
Cargo area light	DOOR	Approximately 20 minutes later

NOTE

- The default setting for this function is set as “operational”. The operational/non-operational setting of this function can be changed by a SUBARU dealer. Contact your SUBARU dealer to change the setting.
- When leaving the vehicle, please make sure that all doors and the rear gate (5-door models) are completely closed.
- The battery drainage prevention function does not operate while the key is in the ignition switch.

Alarm system

The alarm system helps to protect your vehicle and valuables from theft. The horn sounds and the hazard warning flashers flash if someone attempts to break into your vehicle.

For models with “keyless access with push-button start system”:

The system can be armed or disarmed with the keyless access function or access key fob.

The system will not be activated when the push-button ignition switch is in the “ACC” or “ON” position.

For models without “keyless access with push-button start system”:

The system can be armed or disarmed with the remote transmitter.

The system will not be activated when the key is inserted into the ignition switch.

Your vehicle’s alarm system has been set for activation at the time of shipment from the factory. You can set the system for deactivation yourself or have it done by your SUBARU dealer.

■ Alarm system operation

When the alarm system is armed, it is triggered by the opening any of the doors, the rear gate (5-door models) or trunk lid (sedan).

The alarm system will activate the following alarms when triggered.

- The vehicle's horn will sound for 30 seconds.
- The hazard warning flashers will flash for 30 seconds.

If any of the doors or the rear gate/trunk lid remains open after the 30-second period, the horn will continue to sound for a maximum of 3 minutes. If the door or the rear gate/trunk lid is closed while the horn is sounding, the horn will stop sounding with a delay of up to 30 seconds.

NOTE

The alarm system can be set to trigger the illumination of the following interior lights.

- **Map lights** (illuminates only when the map lights switch is in the "DOOR" position)
- **Dome light** (illuminates only when the dome light switch is in the "DOOR" position)
- **Cargo area light** (illuminates only when the cargo area light switch is in

the "DOOR" position)

The notifications regarding the map lights, dome light and cargo area light are deactivated as the factory setting. A SUBARU dealer can activate the system. Contact your SUBARU dealer for details.

■ Arming the system

The alarm system becomes armed when the following operation is performed.

1. Close all windows and the moonroof (if equipped) and turn the ignition switch to the "OFF" position.
2. Carry the key and get out of the vehicle.
3. Lock the doors using any of the following methods.
 - Locking using the remote keyless entry system. For details, refer to "Remote keyless entry system" 2-19.
 - Locking using the keyless access function (if equipped). For details, refer to "Locking with the door lock sensor" 2-10.
 - Locking using the power door locking switch. For details, refer to "Locking using power door locking switch" 2-24.

NOTE

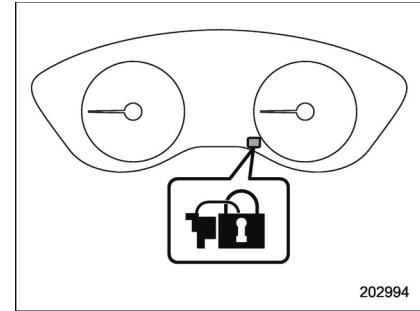

Security indicator light

All doors and the rear gate (5-door models) will lock, an electronic chirp will sound once, the hazard warning flashers will flash once, and the security indicator light will start flashing rapidly.

4. Approximately 30 seconds later, the system will enter surveillance state.

When the system is in surveillance state, the security indicator light will then flash slowly (twice approximately every 2 seconds), indicating that the system has been armed for surveillance.

NOTE

- The system can be armed even if the engine hood, windows and/or moonroof are open. Always make sure that they are fully closed before arming the system.
- When arming the system, if any of the doors or the rear gate/trunk lid is not fully closed, an electronic chirp sounds five times, the hazard warning flashers flash five times to alert you that the doors (or the rear gate/trunk lid) are not properly closed. When you close the door, doors will automatically lock and the system will automatically arm in 30 seconds.
- The 30-second standby time can be eliminated if you prefer. Have it performed by your SUBARU dealer.
- For sedan, if you open the trunk using the access key fob/remote transmitter's  button with the alarm system armed, the system will be temporarily placed in a standby state. The system will go back to the surveillance state upon locking the trunk.
- If any of the following actions is done during the standby period, the system will not switch to the surveillance state.
 - Doors (including the rear gate/trunk lid) are unlocked using the

access key fob/remote transmitter.

- Doors (including the rear gate/trunk lid) are unlocked using the keyless access function (models with “keyless access with push-button start system”).
- Any door (including the rear gate/trunk lid) is opened.
- The ignition switch is turned to the “ON” position (models without “keyless access with push-button start system”).
- Push-button ignition switch is turned to the “ACC” position (models with “keyless access with push-button start system”).

■ Disarming the system

Perform either of the following procedures.

- Briefly press a button (for less than 2 seconds) on the access key fob/remote transmitter.
- Carry the access key fob and perform either of the following procedures (models with “keyless access with push-button start system”).
 - Grip the front door handle.
 - Press the rear gate opener button (5-door models).
 - Unlock using the PIN code access.

The flashing of the security indicator light



will then change slowly (once approximately every 3 seconds from twice approximately every 2 seconds), indicating that the alarm system has been disarmed.

▼ Emergency disarming

If you cannot disarm the system using the access key fob/transmitter (i.e. the transmitter is lost, broken or the transmitter battery is too weak), you can disarm the system without using the access key fob/remote transmitter.

The system can be disarmed if you turn the ignition switch from the “LOCK”/“OFF” to the “ON” position with a registered key/access key fob.

NOTE

For models with “keyless access with push-button start system”, if the access key fob battery is discharged, perform the procedure described in “Switching power status”  9-18. In such a case, replace the battery immediately. Refer to “Replacing battery of access key fob”  11-45.

■ Alarm system setting

To change the setting of your vehicle's alarm system for activation or deactivation, do the following.

1. Disarm the alarm system. Refer to "Disarming the system" 2-28.
2. Sit in the driver's seat and shut all doors and the rear gate (5-door models).
3. Turn the ignition switch to the "ON" position.
4. Hold down the unlock side of the driver's power door locking switch, open the driver's door within the following 1 second, and wait 10 seconds without releasing the switch. The setting will then be changed as follows.

- Type A combination meter

Setting status	Combination meter display	Horn
Activate	AL on	Once
Deactivate	AL oF	Twice

- Type B combination meter

Setting status	Combination meter display	Horn
Activate	ALON	Once
Deactivate	ALOF	Twice

NOTE

You may have the above setting change done by your SUBARU dealer.

■ If you have accidentally triggered the alarm system

▼ To stop the alarm

Do any of the following operations:

- Press any button on the access key fob/remote transmitter.
- Turn the ignition switch to the "ON" position (models without "keyless access with push-button start system").
- Turn the push-button ignition to the "ACC" position (models with "keyless access with push-button start system").

NOTE

Only registered keys will stop the alarm. If the immobilizer transponder is not registered, the alarm will not stop.

■ Valet mode

When you choose the valet mode, the alarm system does not operate. In valet mode, the remote transmitter is used only for locking and unlocking the doors and rear gate (5-door models) and panic activation.

To enter the valet mode, change the setting of your vehicle's alarm system for deactivation mode. Refer to "Alarm system setting" 2-29. The security indicator light will continue to flash once every 3 seconds indicating that the system is in the valet mode.

To exit valet mode, change the setting of your vehicle's alarm system for activation mode. Refer to "Alarm system setting" 2-29.

Child safety locks

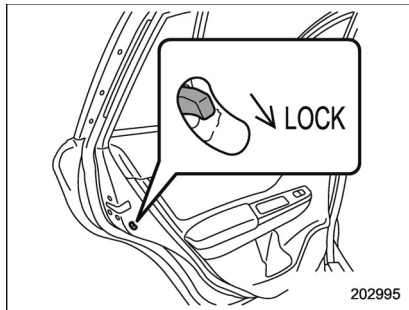

Each rear door has a child safety lock. When the child safety lock lever is in the lock position, the door cannot be opened from inside. The door can only be opened from the outside.

WARNING

Always turn the child safety locks to the "LOCK" position when children sit in the rear seat. Serious injury could result if a child accidentally opens the door and falls out.

Windows

WARNING

To avoid serious personal injury caused by entrapment, always conform to the following instructions without exception.

- When operating the power windows, be extremely careful to prevent anyone's fingers, arms, neck, head or other objects from being caught in the window.
- Always lock the passengers' windows using the lock switch when children are riding in the vehicle.
- Always carry the key when you leave the vehicle for safety reasons and never allow an unattended child to remain in the vehicle. Failure to follow this procedure could result in injury to a child operating the power window.

The power windows operate only when the ignition switch is in the "ON" position.

■ Power window operation

▼ Power window switches

- Driver's side power window switches:

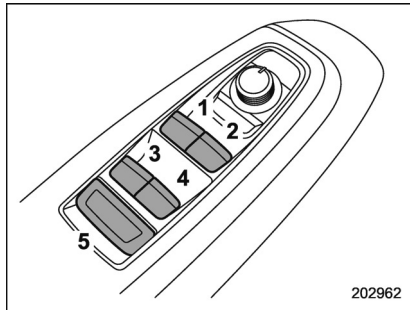

- 1) For front left window (with one-touch auto up and down feature)
- 2) For front right window (with one-touch auto up and down feature)
- 3) For rear left window
- 4) For rear right window
- 5) Lock switch

All door windows can be controlled by the power window switch cluster at the driver side door.

- Passenger's side power window switches:

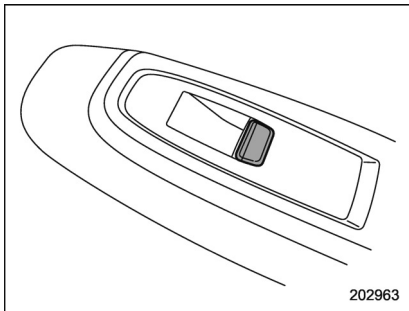

Each passenger window can be controlled by the power window switch located on the door.

▼ Operating the window

- With one-touch auto up and down feature:

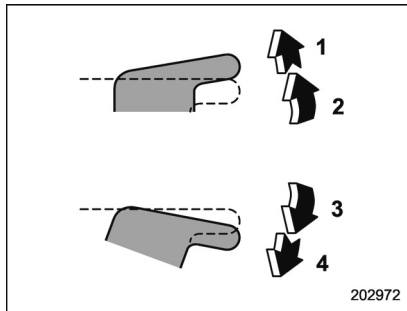

- 1) Automatically close*
- 2) Close
- 3) Open
- 4) Automatically open*

*: To stop the window halfway, operate the switch to opposite side.

NOTE

Avoid the following.

- After the driver's window is fully closed or fully opened, the switch is continuously operated in the same direction for a few seconds.
- After the windows for three or more seats are fully closed or fully opened, each switch is continuously operated

in the same direction simultaneously for a few seconds.

Either of the operations described above may cause the power window breaker to operate making it impossible to open or close the window. Be sure to initialize the power windows. If they are not initialized, the one-touch auto up/down function will not operate. Refer to "Initialization of power window with one-touch auto up/down function" 2-32.

- Without one-touch auto up and down feature:

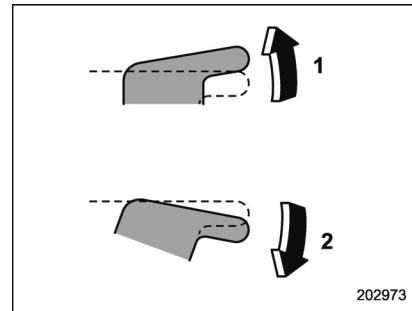

- 1) Close
- 2) Open

▼ Anti-entrapment function (windows with one-touch auto up/down function)

While closing the driver's and front passenger's windows automatically, if the window senses a substantial enough object trapped between the window and the window frame, it automatically moves down slightly and stops.

If a foreign object is caught while the driver's window or passenger's window is opening automatically, the window will stop.

CAUTION

- Never attempt to test this function using fingers, hands or other parts of your body.
- The anti-entrapment function may not operate properly if some object gets trapped just before the window fully closes.

NOTE

- If a window detects an impact similar to that caused by trapping an object (for example, when the vehicle encounters a deep pothole), the anti-entrapment function may operate.
- The window cannot be operated for

a few seconds after the anti-entrapment function operates.

▼ Off delay function (windows with one-touch auto up/down function)

The front windows can be operated for approximately 45 seconds even after the ignition switch is turned to the "ACC" or "OFF" position. If a front door is opened within 45 seconds, the off delay function is canceled.

▼ Locking the passengers' windows

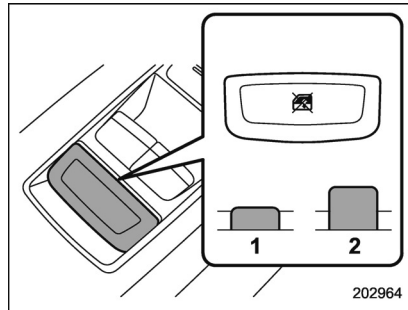

- 1) Lock
- 2) Unlock

When the lock switch is in the lock position, the passengers' windows cannot be opened or closed.

■ Initialization of power window with one-touch auto up/down function

If the power window automatic function (one-touch auto up and down function) does not operate properly, operate each window according to the following procedure in order to initialize the power window system.

1. Close the door.
2. Turn the ignition switch to the "ON" position.
3. Open the window completely and then press and hold down the power window switch for approximately 1 second.
4. Close the window completely and then pull and hold the power window switch for approximately 1 second.

Trunk lid (sedan)

WARNING

- To prevent dangerous exhaust gas from entering the vehicle, always keep the trunk lid closed while the engine is running.
- Help prevent children, adults or animals from locking themselves in the trunk. On hot or sunny days, the temperature in the trunk could quickly become high enough to cause death or serious heat-related injuries including brain damage to anyone locked inside, particularly for small children.
- When leaving the vehicle, either close all windows and lock all doors. Also make certain that the trunk is closed.

■ To open and close the trunk lid from outside

The trunk lid can be opened using the keyless access function or remote keyless entry system. For details, refer to the following section.

- For models with “keyless access with push-button start system”, refer to “Opening trunk (sedan)” 2-11 or “Opening the trunk lid (sedan)” 2-21.
- For models without “keyless access with push-button start system”, refer to “Opening the trunk lid (sedan)” 2-21.

To close the trunk lid, lightly press the trunk lid down until the latch engages.

NOTE

- Do not leave your valuables in the trunk when you leave your vehicle.
- Under the following conditions, the trunk can be opened without the access key fob.
 - the trunk lock/unlock setting is set to on
 - all doors are unlocked

The trunk lock/unlock setting can be changed by a SUBARU dealer. Contact your SUBARU dealer to change the setting.

■ To open the trunk lid from inside

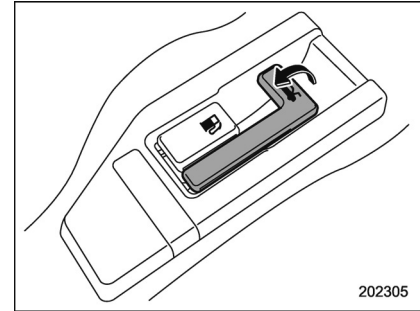

Pull the trunk lid release lever upward. The lever is on the floor at the left of the driver's seat.

■ Internal trunk lid release handle

The internal trunk lid release handle is a device designed to open the trunk lid from inside the trunk. In the event children or adults become locked inside the trunk, the handle allows them to open the lid. The handle is located on the inside of the trunk lid.

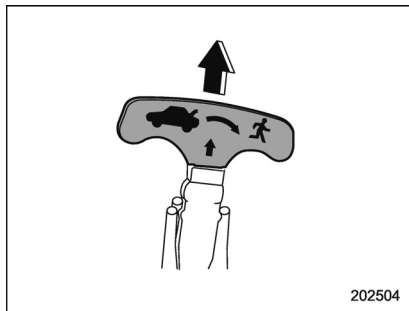

To open the trunk lid from inside the trunk, pull the trunk lid release handle upward as indicated by the arrow on the handle.

This operation unlocks the trunk lid. Then, push up the lid.

The handle is made of material that remains luminescent for approximately an hour in the dark trunk space after it is exposed to ambient light even for a short

time.

▲ WARNING

Never allow any child to get in the trunk and play with the release handle. If the driver starts the vehicle without knowing that a child is inside the trunk and the child opens the lid using the release handle, the child could fall out and be killed or seriously injured.

▲ CAUTION

- Do not close the lid while gripping the release handle. The handle may be damaged.
- Do not use the handle as a hook to fasten straps or ropes to secure your cargo in the trunk. Such use may result in damage of the handle.

- Load the trunk so that cargo can not strike the release handle. If the cargo hits the handle while the vehicle is being driven, the handle may be pulled up and the trunk lid may open. That may cause cargo to fall out of the trunk, which could create a traffic safety hazard.

▼ Inspection

Perform the following steps at least twice a year to check the release handle for correct operation.

1. Open the trunk lid.

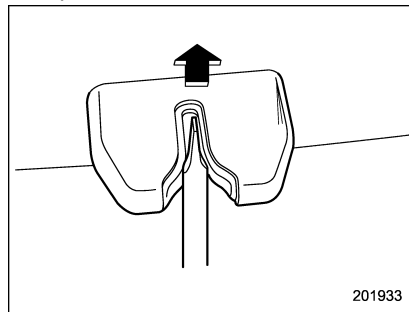

2. Use a flat-head screwdriver with a thin blade. Slide the flat-head screwdriver blade from the slit aperture of the lock

assembly fully to the end until you hear a click.

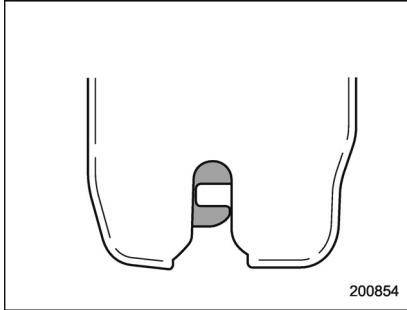

This places the latch in the locked position.

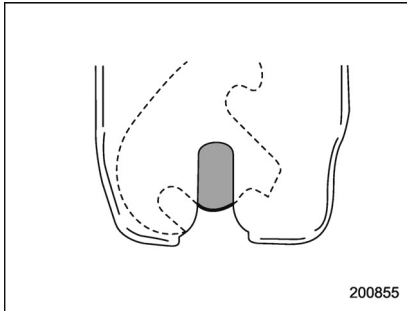

3. Pull the release handle upward and check that the latch is released.

If the latch is not released, contact your SUBARU dealer.

In this case, press the “” button on the key lug to release the latch, then close the trunk lid.

Also, if the movement of the trunk lid release handle feels restricted or not entirely smooth during operation, or the handle and/or handle base is cracked, contact your SUBARU dealer.

Rear gate (5-door models)

WARNING

- To prevent dangerous exhaust gas from entering the vehicle, always keep the rear gate closed while the engine is running.
- Do not attempt to shut the rear gate while holding the recessed grip. Also avoid closing the rear gate by pulling on the recessed grip from inside the cargo space. There is a danger of your hand being caught and injured.

NOTE

If the rear gate cannot be unlocked due to a discharged vehicle battery, a malfunction in the door locking/unlocking system or other causes, you can unlock it by manually operating the rear gate lock release lever.

For the procedure, refer to “Rear gate – if the rear gate cannot be opened”  9-20.

■ Lock/unlock

The rear gate can be locked and unlocked using any of the following systems.

- Power door locking switch: Refer to “How to operate the power door locking switches” 2-25.
- Keyless access with the push-button start system (if equipped): Refer to “Keyless access with push-button start system” 2-3.
- Remote keyless entry system: Refer to “Remote keyless entry system” 2-19.

■ Open/close

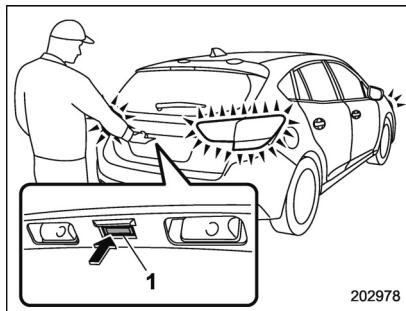

- 1) The rear gate opener button

To open:

First unlock the rear gate lock then push the rear gate opener button.

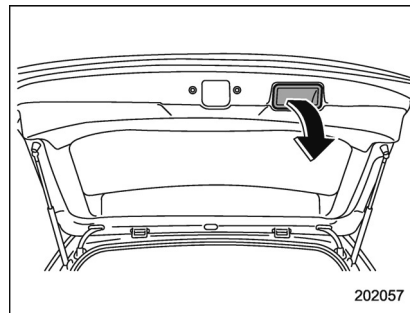

To close:

Lower the rear gate slowly and push down firmly until the latch engages.

The rear gate can be lowered easily if you pull it down holding the recessed grip.

▲ CAUTION

- Do not jam a plastic bag in or place cellophane tape on the rear gate stays or scratch the stays while loading or unloading cargo. That could cause leakage of gas from the stays, which may result in their inability to hold the rear gate open.
- Be careful not to hit your head or face on the rear gate when opening or closing the rear gate and

when loading or unloading cargo.

Moonroof (if equipped)

WARNING

Never let anyone's hands, arms, head or any objects protrude from the moonroof. A person could be seriously injured if any of the following conditions occur.

- The vehicle stops suddenly.
- The vehicle turns sharply.
- The vehicle is involved in an accident.
- Body parts protruding from the vehicle are struck by outside objects.

To avoid serious personal injury caused by entrapment, always conform to the following instructions without exception.

- Before closing the moonroof, make sure that no one's hands, arms, head or other objects will be accidentally caught in the moonroof.
- Always carry the key when you leave the vehicle for safety reasons and never allow an unattended child to remain in the

vehicle. Failure to follow this procedure could result in injury to a child operating the moonroof.

- Never try to check the anti-entrapment function by deliberately placing part of your body in the moonroof.

CAUTION

- Do not sit on the edge of the open moonroof.
- Do not operate the moonroof if falling snow or extremely cold conditions have caused it to freeze shut.
- The anti-entrapment function does not operate when the moonroof is being tilted down. Be sure to confirm that it is safe to do so before tilting the moonroof down.
- If the moonroof does not close, have the system checked by a SUBARU dealer.

The moonroof has both tilting and sliding functions.

The moonroof operates only when the ignition switch is in the "ON" position.

■ Moonroof switches

▼ Tilting moonroof

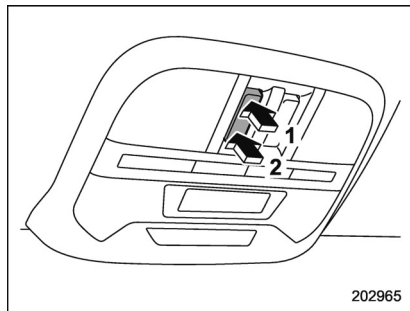

- 1) Up
- 2) Down

To raise the moonroof, press and hold the switch in the up side and release. To lower the moonroof, press and hold the switch in the down side.

NOTE

Release the switch after the moonroof has been raised or has been lowered completely. Pressing the switch continuously may cause damage to the moonroof.

▼ Sliding moonroof

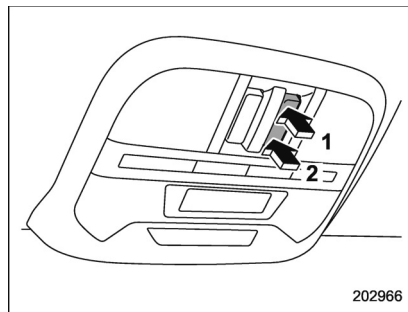

- 1) Open
- 2) Close

To open or close the moonroof using the automatic function, press and hold the switch toward the open/close side and release.

To stop the moonroof halfway, press a switch on the moonroof switch.

NOTE

After washing the vehicle or after it rains, wipe away water on the roof prior to opening the moonroof to prevent drops of water from falling into the passenger compartment.

▼ Anti-entrapment function

When the moonroof senses a substantial enough object trapped between its glass and the vehicle's roof during closure, it automatically moves back to the fully open position and stops there. The anti-entrapment function may also be activated by a strong shock on the moonroof even when there is nothing trapped.



CAUTION

Never attempt to test this function using fingers, hands or other parts of your body.

NOTE

For the sake of safety, it is recommended that you avoid driving with the moonroof fully opened.

■ Sun shade

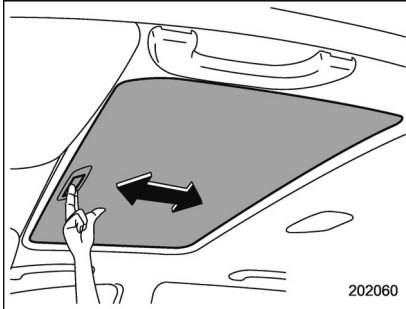

The sun shade can be slid forward or backward by hand while the moonroof is closed.

If the moonroof is opened, the sun shade also moves back.

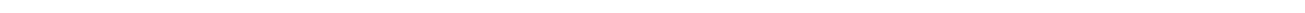
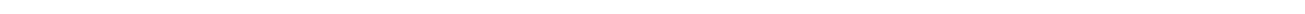
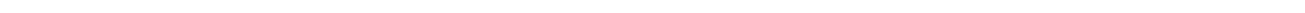
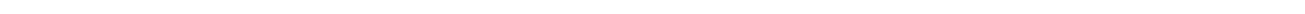
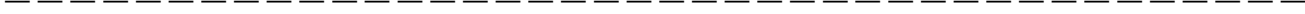
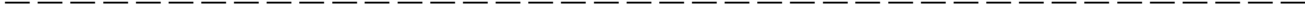
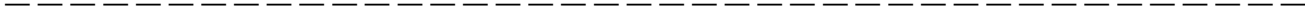
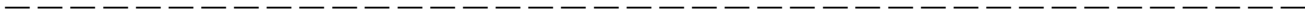
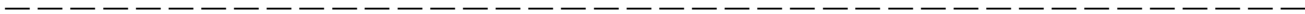
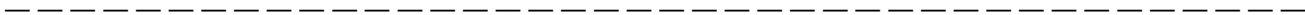

Ignition switch (models without “keyless access with push-button start system”).....	3-4	CHECK ENGINE warning light/Malfunction indicator light	3-16
Key positions	3-4	Coolant temperature low indicator light/Coolant temperature high warning light.....	3-17
Key reminder chime	3-5	Charge warning light.....	3-18
Ignition switch light (if equipped).....	3-5	Oil pressure warning light.....	3-18
Push-button ignition switch (models with “keyless access with push-button start system”).....	3-6	Engine low oil level warning light	3-18
Safety precautions	3-6	Windshield washer fluid warning light	3-19
Operating range for push-button start system	3-6	AT OIL TEMP warning light (CVT models)	3-19
Switching power status	3-7	Low tire pressure warning light (U.S.-spec. models)	3-19
When access key fob does not operate properly	3-8	ABS warning light.....	3-21
Hazard warning flasher	3-8	Brake system warning light (red).....	3-21
Meters and gauges.....	3-9	Low fuel warning light	3-22
Speedometer.....	3-9	Hill start assist warning light/Hill start assist OFF indicator light	3-23
Tachometer	3-9	Door open warning light	3-23
Odometer.....	3-9	All-Wheel Drive warning light (CVT models).....	3-23
Double trip meter	3-9	Power steering warning light.....	3-23
Fuel gauge.....	3-10	Vehicle Dynamics Control warning light/Vehicle Dynamics Control operation indicator light.....	3-24
ECO gauge (if equipped)	3-11	Vehicle Dynamics Control OFF indicator light.....	3-25
Combination meter settings.....	3-11	Warning chimes and warning indicator of the keyless access with push-button start system (if equipped)	3-25
Illumination brightness control	3-12	Security indicator light.....	3-30
Auto dimmer cancel function (if equipped).....	3-13	Select lever/gear position indicator (CVT models)	3-31
Warning and indicator	3-13	Turn signal indicator lights.....	3-31
Initial illumination for system check.....	3-13	High beam indicator light.....	3-31
Seatbelt warning light and chime	3-14	High beam assist indicator light (green) (if equipped)	3-31
SRS airbag system warning light.....	3-15		
Front passenger’s frontal airbag ON and OFF indicators.....	3-16		

High beam assist warning indicator (yellow) (if equipped).....	3-31	Multi-function display (black and white)	3-43
Cruise control indicator light (if equipped)	3-32	Driving information display	3-44
Cruise control set indicator light (if equipped).....	3-32	Outside temperature indicator	3-47
Automatic headlight beam leveler warning light (models with LED headlights)	3-32	Clock	3-48
LED headlight warning light (models with LED headlights).....	3-32	Multi-function display (color LCD) (if equipped)	3-48
Steering Responsive Headlight warning light/ Steering Responsive Headlight OFF indicator light (if equipped)	3-32	Features	3-49
Front fog light indicator light (if equipped)	3-32	Welcome screen	3-49
Headlight indicator light (if equipped)	3-32	Self-check screen	3-49
Steering responsive fog lights warning indicator/ Steering responsive fog lights OFF indicator (if equipped).....	3-32	Interruption screen	3-50
BSD/RCTA warning indicator (if equipped)	3-33	Basic operation	3-50
BSD/RCTA OFF indicator (if equipped)	3-33	Basic screens.....	3-51
RAB warning indicator (if equipped)	3-33	Setting screen	3-58
RAB OFF indicator light (if equipped).....	3-33	How to get the source code using the open source.....	3-63
Icy road surface warning indicator (if equipped).....	3-33	Clock	3-63
Combination meter display (color LCD) (if equipped).....	3-34	Preparation for clock adjustment setting	3-64
Basic operation.....	3-35	Clock setting with automatically	3-64
Welcome screen and Good-bye screen	3-35	Clock setting with manually	3-64
Warning screen.....	3-36	Regulatory information	3-65
Telltale screen.....	3-36	Light control switch.....	3-66
Basic screens	3-37	Precautions and tips.....	3-66
Menu screens	3-39	Headlights	3-66
		High/low beam change (dimmer)	3-68
		Headlight flasher	3-68
		High beam assist function (if equipped).....	3-68
		Daytime running light system.....	3-71
		Steering Responsive Headlight (SRH) (if equipped)	3-72
		Headlight beam leveler (models with LED headlights)	3-73

Fog light switch (if equipped)	3-73	Mirrors	3-79
Steering responsive fog lights system (if equipped).....	3-73	Inside mirror.....	3-79
Turn signal lever	3-75	Auto-dimming mirror/compass (if equipped)	3-79
One-touch lane changer	3-75	Auto-dimming mirror/compass with HomeLink® (if equipped)	3-80
Wiper and washer	3-75	Outside mirrors	3-87
Windshield wiper and washer switches	3-77	Defogger and deicer (if equipped)	3-88
Rear window wiper and washer switch (5-door models).....	3-78	Tilt/telescopic steering wheel	3-90
		Heated Steering Wheel system (if equipped).....	3-90
		Horn	3-91

Ignition switch (models without “keyless access with push-button start system”)

WARNING

- Never turn the ignition switch to the “LOCK” position while the vehicle is being driven or towed because that will lock the steering wheel, preventing steering control. And when the engine is turned off, it takes a much greater effort than usual to steer.
- Before leaving the vehicle, always remove the key from the ignition switch for safety and never allow an unattended child to remain in the vehicle. Failure to follow this procedure could result in injury to a child or others. Children could operate the power windows, the moon-roof or other controls or even make the vehicle move.

CAUTION

Do not attach a large key holder or key case to either key. If it banged against your knees or hands while you are driving, it could turn the ignition switch from the “ON” position to the “ACC” or “LOCK” position, thereby stopping the engine. Also, if the key is attached to a key holder or to a large bunch of other keys, centrifugal force may act on it as the vehicle moves, resulting in unwanted turning of the ignition switch.

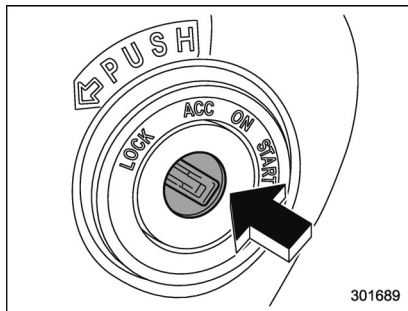

The ignition switch has four positions: LOCK, ACC, ON and START.

NOTE

- Keep the ignition switch in the “LOCK” position when the engine is not running.
- Using electrical accessories for a long time with the ignition switch in the “ON” or “ACC” position can cause the battery to go dead.
- If the ignition switch will not move from the “LOCK” position to the “ACC” position, turn the steering wheel slightly to the left and right as you turn the ignition switch.

Key positions

Position	Description
LOCK	The key can only be inserted or removed in this position. The ignition switch will lock the steering wheel when you remove the key.
ACC	In this position the electrical accessories (audio, accessory power outlet, etc.) can be used.
ON	This is the normal operating position after starting the engine.
START	The engine is started in this position.

CAUTION

Do not turn the ignition switch to the "START" position while the engine is running.

NOTE

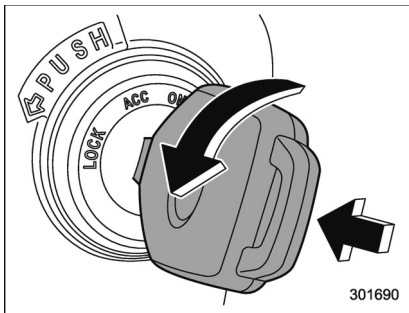

- To turn the key from the "ACC" to "LOCK" position, the select lever must be in the "P" position (CVT models) and the key must be pushed in and turned.
- If your registered key fails to start the engine, pull out the key once (the security indicator light will blink), and then insert the key again and turn it to the "START" position again to restart

the engine.

- The engine may not start in the following cases:

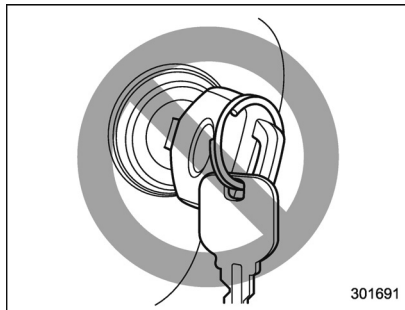

- The key grip is touching another key or a metallic key holder.

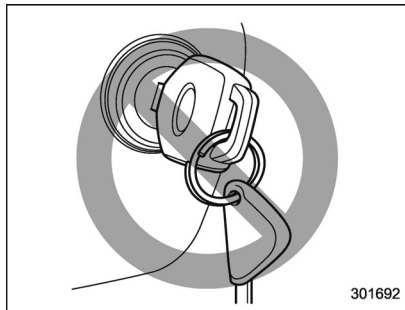

- The key is near another key that

contains an immobilizer transmitter.

- The key is near or touching another transmitter.

■ Key reminder chime

The reminder chime sounds when the driver's door is opened and the ignition switch is in the "LOCK" or "ACC" position.

The chime stops under the following conditions.

- when the ignition switch is turned to the "ON" position
- when the key is removed from the ignition switch
- when the driver's door is closed

■ Ignition switch light (if equipped)

For easy access to the ignition switch in the dark, the ignition switch light illuminates when the driver's door is opened or when the driver's door is unlocked using the remote keyless entry transmitter.

The light remains illuminated for several tens of seconds and then gradually turns off under the following conditions.

- when the driver's door is closed
- when the doors are unlocked using the

remote keyless entry transmitter

The light turns off immediately under the following conditions.

- when the ignition switch is turned to the “ON” position
- when all doors and the rear gate (5-door models) are locked using the remote keyless entry transmitter

Push-button ignition switch (models with “keyless access with push-button start system”)

■ Safety precautions

Refer to “Safety precautions” 2-4.

■ Operating range for push-button start system

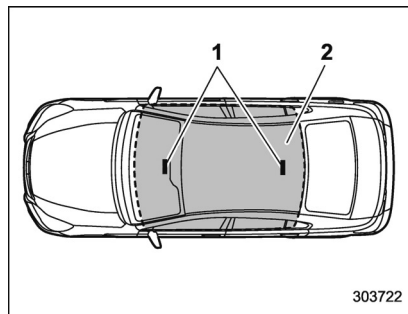

Sedan

- 1) Antenna
- 2) Operating range

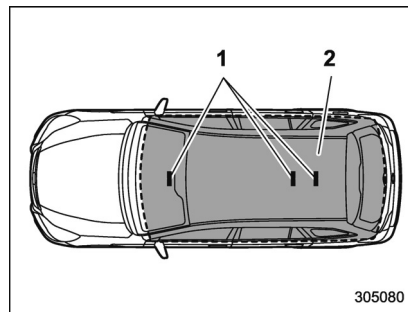

5-door models

- 1) Antenna
- 2) Operating range

NOTE

- If the access key fob is not detected within the operating range of the antennas inside the vehicle, the push-button ignition switch and the engine start cannot be operated.
- Even when the access key fob is outside the vehicle, if it is placed too close to the glass, it may be possible to switch the power or to start the engine.
- Do not leave the access key fob in the following places. It may become impossible to operate the push-button ignition switch and the engine start. It may also cause a false warning to

issue although no malfunction actually occurs, or not to issue a warning when any malfunction occurs.

- On the instrument panel
 - On the floor
 - Inside the glove box
 - Inside the door trim pocket
 - On the rear seat
 - On the rear shelf (sedan)
 - Inside the trunk (sedan)
 - In the cargo area (5-door models)
- When operating the push-button ignition switch or starting the engine, if the access key fob battery is discharged, perform the procedure described in "Access key fob – if access key fob does not operate properly" 9-18. In such a case, replace the battery immediately. Refer to "Replacing battery of access key fob" 11-45.

Switching power status

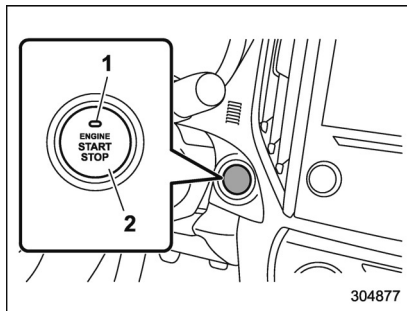

- 1) Operation indicator
- 2) Push-button ignition switch

The power is switched every time the push-button ignition switch is pressed.

1. Carry the access key fob, and sit in the driver's seat.
2. Shift the select lever (CVT models)/the shift lever (MT models) into the "P"/"N" position.
3. Press the push-button ignition switch without depressing the brake pedal. Every time the button is pressed, the power is switched in the sequence of "OFF", "ACC", "ON" and "OFF". When the engine is stopped and the push-button ignition switch is in "ACC" or "ON", the operation indicator on the push-button ignition

switch illuminates in orange.

Power status	Indicator color	Operation
OFF	Turned off	Power is turned off.
ACC	Orange	The following systems can be used: audio and accessory power outlet.
ON	Orange (while engine is stopped)	All electrical systems can be used.
	Turned off (while engine is running)	



CAUTION

- When the push-button ignition switch is left in "ON" (while the engine is not running) or "ACC" for a long time, it may result in vehicle battery discharge.
- Do not spill drinks or other liquids on the push-button ignition switch. It may cause a malfunction.
- Do not touch the push-button ignition switch with a hand soiled

with oil or other contaminants. It may cause a malfunction.

- If the push-button ignition switch does not operate smoothly, stop the operation. Contact a SUBARU dealer immediately.
- If the push-button ignition switch does not illuminate even when the instrument panel illumination is turned on, have the vehicle inspected at a SUBARU dealer.
- If the vehicle was left in the hot sun for a long time, the surface of the push-button ignition switch may get hot. Be careful not to burn yourself.

NOTE

- When operating the push-button ignition switch, firmly press it all the way.
- If the push-button ignition switch is pressed quickly, the power may not turn on or off.

- If the indicator light on the push-button ignition switch flashes in green when the push-button ignition switch is pressed, steering is locked. When this occurs, press the push-button ignition switch while turning the steering wheel left and right.

▼ Battery drainage prevention function

When the push-button ignition switch is left in the "ACC" or "ON" position for approximately 1 hour, the push-button ignition switch will be automatically switched to "OFF" to prevent the battery from going dead.

■ When access key fob does not operate properly

Refer to "Access key fob – if access key fob does not operate properly" 9-18.

Hazard warning flasher

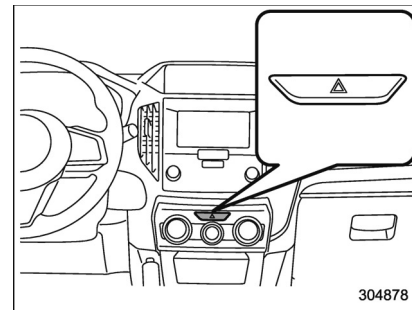

The hazard warning flasher is used to warn other drivers when you have to park your vehicle under emergency conditions. The hazard warning flasher works regardless of the position of the ignition switch.

To turn on the hazard warning flasher, push the hazard warning button on the instrument panel. All the turn signal lights and the turn signal indicator lights will flash. To turn off the flasher, push the button again.

NOTE

When the hazard warning flasher is on, the turn signals do not work.

Meters and gauges

NOTE

Some of the meters and gauges on the combination meter use liquid-crystal displays. You will find their indications hard to see if you wear polarized glasses.

Speedometer

The speedometer shows the vehicle speed.

Tachometer

The tachometer shows the engine speed in thousands of revolutions per minute.

CAUTION

Do not operate the engine with the pointer of the tachometer in the red zone. In this range, fuel injection will be cut by the engine control module to protect the engine from overrevving. The engine will resume running normally after the engine speed is reduced below the red zone.

NOTE

To protect the engine/transmission while the select lever is in the “P” or “N” position (CVT models) or the shift lever is in the neutral position (for MT models), the engine is controlled so that the engine speed may not become too high even if the accelerator pedal is pressed hard.

Odometer

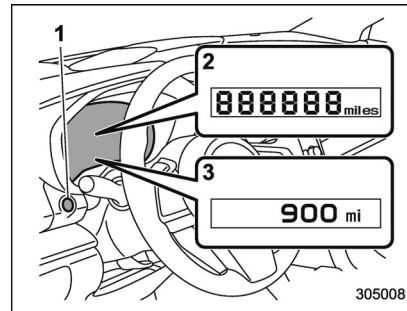

- 1) TRIP RESET switch
- 2) Type A combination meter
- 3) Type B combination meter

This meter displays the odometer when the ignition switch is in the “ON” position. The odometer shows the total distance that the vehicle has been driven.

NOTE

If you press the TRIP RESET switch when the ignition switch is in the “LOCK”/“OFF” or “ACC” position, the odometer/trip meter will light up.

The indicators will turn off when:

- The TRIP RESET switch is not operated for approximately 10 seconds.
- The driver’s door is opened and then closed.

Double trip meter

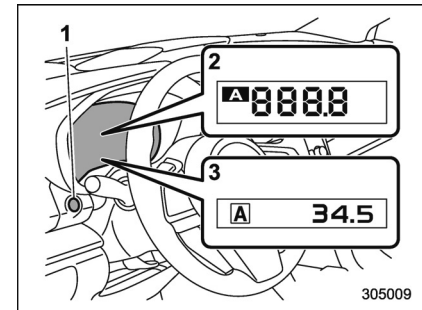

- 1) TRIP RESET switch
- 2) Type A combination meter
- 3) Type B combination meter

This meter displays the two trip meters when the ignition switch is in the “ON”

position.

The trip meter shows the distance that the vehicle has been driven since you last set it to zero.

The display can be switched as shown in the following sequence by pressing the TRIP RESET switch.

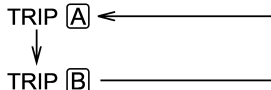

To set the trip meter to zero, select the A trip or B trip meter by pressing the TRIP RESET switch and keep the knob pressed for more than 2 seconds.

CAUTION

To ensure safety, do not attempt to change the function of the indicator during driving, as an accident could result.

NOTE

- If the connection between the combination meter and battery is broken for any reason such as vehicle maintenance or fuse replacement, the data recorded on the trip meter will be lost.
- If you press the TRIP RESET switch when the ignition switch is in the “LOCK”/“OFF” or “ACC” position, the odometer/trip meter will light up. It is possible to switch between the A trip meter and B trip meter indications while the odometer/trip meter is lit up. In addition, it is possible to reset the trip meter by pressing and holding the TRIP RESET switch.

The indicators will turn off when:

- The TRIP RESET switch is not operated for approximately 10 seconds.
- The driver’s door is opened and then closed.

Fuel gauge

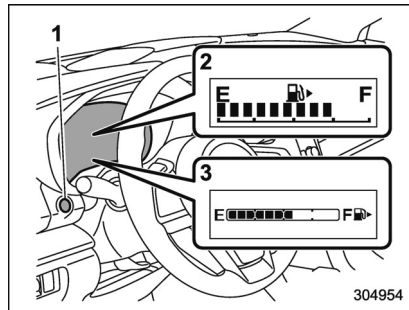

- 1) TRIP RESET switch
- 2) Type A combination meter
- 3) Type B combination meter

The fuel gauge is displayed when the ignition is in the “ON” position, and it shows the approximate amount of fuel remaining in the tank.

The gauge indication may change slightly during braking, turning or acceleration due to fuel level movement in the tank.

NOTE

- You will see the “▶” sign in the fuel gauge. This indicates that the fuel filler door (lid) is located on the right side of the vehicle.
- If you press the TRIP RESET switch

while the ignition switch is in the "LOCK"/"OFF" or "ACC" position, the fuel gauge will light up and indicate the amount of fuel remaining in the tank.

The indicators will turn off when:

- The TRIP RESET switch is not operated for approximately 10 seconds.
- The driver's door is opened and then closed.

■ ECO gauge (if equipped)

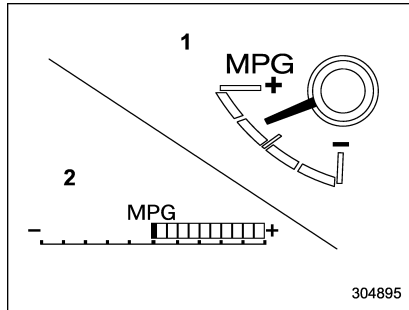

- 1) Type A combination meter
- 2) Type B combination meter

The ECO gauge shows the difference between the current rate of fuel consumption and the average rate of fuel consumption since the trip meter was last reset.

If the ECO gauge moves towards the + side, this indicates better fuel efficiency.

NOTE

- The ECO gauge shows only an approximate indication of fuel efficiency.
- After resetting the trip meter, the average rate of fuel consumption is not shown until you have driven for 1 mile (or 1 km). Before that time, the ECO gauge does not operate.

■ Combination meter settings

Meter and vehicle settings can be set on the combination meter.

▼ Type A combination meter

Various adjustments can be made, such as switching units shown on the combination meter and adjusting the warning tone volume.

While the ignition switch is in the "OFF" position, each press of TRIP RESET switch results in items shown in the table below being switched.

Item	Combination meter display	Possible settings
A trip	A 8888	—
B trip	B 5555	—
Gauge needle sweep function	1 on	On/Off
Changing the unit*	2 MPH	mile/km
Warning volume*	3Lv.2	Lv. 1/Lv. 2/Lv. 3

*: if available

NOTE

- If you switch the units on the combination meter, the units on the multi-function display (black and white) also switches accordingly.
- If either of the following conditions is met, the combination meter setting mode will be canceled.
 - The driver's door is opened.
 - The TRIP RESET switch is not operated for approximately 10 seconds or more.

▽ **Switching method**

1. Push the ignition switch in the "OFF" position.

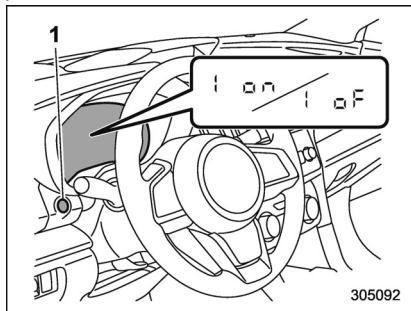

1) TRIP RESET switch

2. Press the TRIP RESET switch repeatedly until the item you want to change is displayed.
3. Press and hold the TRIP RESET switch while the item to be changed is displayed, the setting of the item will be switched.

▼ **Type B combination meter**

Meter and vehicle settings can be set on the combination meter display (color LCD). Refer to "Menu screens" 3-39.

Illumination brightness control

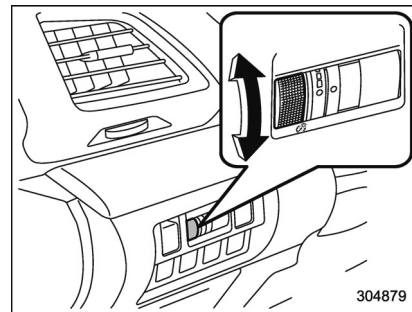

The illumination brightness of the instrument panel illuminates under the following conditions.

- when the light switch is in the "ON" or "D" position
- when the light control switch is in the "AUTO" position and the headlights illuminate automatically

You can adjust the illumination brightness for better visibility.

To brighten, turn the control dial upward.

To darken, turn the control dial downward.

NOTE

- When the control dial is turned fully upward, the illumination brightness becomes the maximum and the automatic dimming function does not work at all.
- The brightness setting is not canceled even when the ignition switch is turned to the “LOCK”/“OFF” position.

■ Auto dimmer cancel function (if equipped)





When the ambient light is bright, the illumination brightness is set to the maximum regardless of the position of the control dial. In this case, you cannot adjust the illumination brightness by using the control dial. When the ambient light is dark, you can dim the illumination brightness as described above.















The operational/non-operational setting and sensitivity of the auto dimmer cancel function can be changed by your SUBARU dealer. Contact your SUBARU dealer for details.

Warning and indicator**■ Initial illumination for system check**

Several of the warning and indicator lights illuminate when the ignition switch is initially turned to the “ON” position. This permits checking the operation of the bulbs.

Apply the parking brake and turn the ignition switch to the “ON” position. For the system check, several of the following lights illuminate and then turn off after several seconds or after the engine has started.

- : Seatbelt warning light
(The seatbelt warning light turns off only when the driver fastens the seatbelt.)
- PASSENGER : Front passenger's seatbelt warning light
(The seatbelt warning light turns off only when the front seat passenger fastens the seatbelt.)
- : SRS airbag system warning light
- ON / : Front passenger's frontal airbag ON indicator light
- OFF / : Front passenger's frontal airbag OFF indicator light

- CHECK-ENGINE : CHECK ENGINE warning light/Malfunction indicator light
- : Coolant temperature low indicator light/Coolant temperature high warning light
- : Charge warning light
- : Oil pressure warning light
- : Engine low oil level warning light
- : Windshield washer fluid warning light
- AT OIL-TEMP : AT OIL TEMP warning light (CVT models)
- : Low tire pressure warning light (U.S.- spec. models)
- ABS / : ABS warning light
- BRAKE / : Brake system warning light
- : Low fuel warning light
- : Hill start assist warning light/Hill start assist OFF indicator light
- : Door open warning light
- AWD: AWD warning light (CVT models)
- : Power steering warning light
- : Vehicle Dynamics Control warning light/Vehicle Dynamics Control operation indicator light

 Vehicle Dynamics Control OFF indicator light

 : Cruise control indicator light (if equipped)

 : Cruise control set indicator light (if equipped)

 : Automatic headlight beam leveler warning light (models with LED headlights)

 : Steering responsive fog lights warning indicator/Steering responsive fog lights OFF indicator (if equipped)

If any lights fail to illuminate, it indicates a burned-out bulb or a malfunction of the corresponding system.

Consult your authorized SUBARU dealer for repair.

■ Seatbelt warning light and chime



Your vehicle is equipped with a seatbelt warning device at the driver's and front passenger's seat, as required by current safety standards.

With the ignition switch turned to the "ON" position, this device reminds the driver and front passenger to fasten their seatbelts by illuminating the warning lights in the locations indicated in the following illustration and sounding a chime.

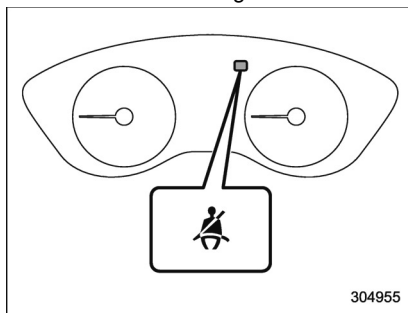

Driver's warning light

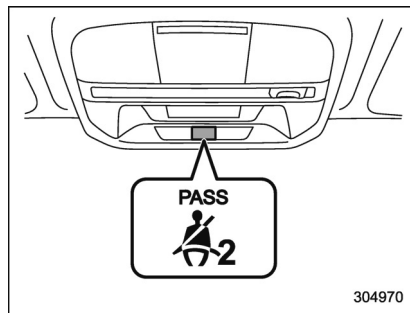

Front passenger's warning light

▼ Operation

If the driver and/or front passenger have/has not yet fastened the seatbelt(s) when the ignition switch is turned to the "ON" position, the seatbelt warning light(s) will flash for 6 seconds, to warn that the seatbelt(s) is/are unfastened. If the driver's seatbelt is not fastened, a chime will also sound simultaneously.

NOTE

- If the driver's and/or front passenger's seatbelt(s) are/is still not fastened 6 seconds later, the seatbelt warning device operates as follows according to the vehicle speed.
 - At speeds lower than approximately 9 mph (15 km/h)

The warning light(s) for unfastened seatbelt(s) will alternate between steady illumination and flashing at 15-second intervals. The chime will not sound.

– At speeds higher than approximately 9 mph (15 km/h)

The warning light(s) for unfastened seatbelt(s) will alternate between flashing and steady illumination at 15-second intervals and the chime will sound while the warning light(s) is/are flashing.

- It is possible to cancel the warning operation that follows the 6-second warning after turning ON the ignition switch. When the ignition switch is turned ON next time, however, the complete sequence of the warning operation resumes. For further details about canceling the warning operation, please contact your SUBARU dealer.

If there is no passenger on the front passenger's seat, the seatbelt warning device for the front passenger's seat will be deactivated. The front passenger's occupant detection system monitors whether or not there is a passenger on the front passenger's seat.

Observe the following precautions. Failure to do so may prevent the device from functioning correctly or cause the device

to fail.

- Do not install any accessory such as a table or TV onto the seatback.
- Do not store a heavy load in the seatback pocket.
- Do not allow the rear seat occupant to place his/her hands or legs on the front passenger's seatback, or allow him/her to pull the seatback.
- Do not use front seats with their backward-forward position and seatback not being locked into place securely. If any of them are not locked securely, adjust them again. For adjusting procedure, refer to "Manual seat" 1-5.

If the seatbelt warning device for the front passenger's seat does not function correctly (e.g., it is activated even when the front passenger's seat is empty or it is deactivated even when the front passenger has not fastened his/her seatbelt), take the following actions.

- Ensure that no article is placed on the seat other than a child restraint system and its child occupant, although we strongly recommend that all children sit in the rear seat properly restrained.
- Ensure that there is no article left in the seatback pocket.
- Ensure that the backward-forward position and seatback of front passenger's

seat are locked into place securely by moving the seat back and forth.

If still the seatbelt warning device for front passenger's seat does not function correctly after taking relevant corrective actions described above, immediately contact your SUBARU dealer for an inspection.

■ SRS airbag system warning light



WARNING

If the warning light exhibits any of the following conditions, there may be a malfunction in the seatbelt pretensioners and/or SRS airbag system. Immediately take your vehicle to your nearest SUBARU dealer to have the system checked. Unless checked and properly repaired, the seatbelt pretensioners and/or SRS airbag will not operate properly in the event of a collision, which may increase the risk of injury.

- Flashing or flickering of the warning light
- No illumination of the warning light when the ignition switch is first turned to the "ON" position

- Continuous illumination of the warning light
- Illumination of the warning light while driving

For details about the components monitored by the warning light, refer to "SRS airbag system monitors" 1-66.

■ Front passenger's frontal airbag ON and OFF indicators

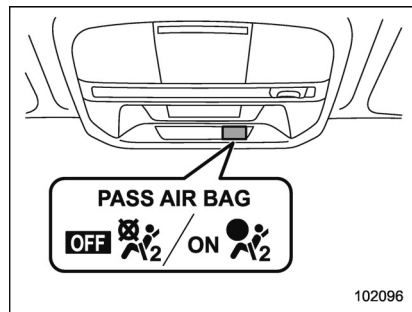

ON 2: Front passenger's frontal airbag ON indicator

OFF 2: Front passenger's frontal airbag OFF indicator

The front passenger's frontal airbag ON and OFF indicators show you the status of the front passenger's SRS frontal airbag.

The indicator is displayed near the map lights.

When the ignition switch is turned to the "ON" position, both the ON and OFF indicators illuminate for 6 seconds during which time the system is checked. Following the system check, both indicators turn off for 2 seconds. After that, one of the indicators illuminates depending on the status of the front passenger's SRS frontal airbag determined by the SUBARU advanced frontal airbag system monitoring.

If the front passenger's SRS frontal airbag is activated, the passenger's frontal airbag ON indicator will illuminate while the OFF indicator will remain off.

If the front passenger's SRS frontal airbag is deactivated, the passenger's frontal airbag ON indicator will remain off while the OFF indicator will illuminate.

With the ignition switch turned to the "ON" position, if both the ON and OFF indicators remain illuminated or off simultaneously even after the system check period, the system is malfunctioning. Contact your SUBARU dealer immediately for an inspection.

■ CHECK ENGINE warning light/Malfunction indicator light

CHECK ENGINE



CAUTION

If the CHECK ENGINE light illuminates while you are driving, have your vehicle checked/repared by your SUBARU dealer as soon as possible. Continued vehicle operation without having the emission control system checked and repaired as necessary could cause serious damage, which may not be covered by your vehicle's warranty.

If this light illuminates steadily or blinks while the engine is running, it may indicate that there is a problem or potential problem somewhere in the emission control system.

▼ If the light illuminates steadily

If the light illuminates steadily while driving or does not turn off after the engine starts, an emission control system malfunction has been detected.

You should have your vehicle checked by an authorized SUBARU dealer immediately.

NOTE

This light also illuminates when the fuel filler cap is not tightened until it clicks.

If you have recently refueled your vehicle, the cause of the CHECK ENGINE warning light/malfunction indicator light illuminating could be a loose or missing fuel filler cap. Remove the cap and retighten it until it clicks. Make sure nothing is interfering with the sealing of the cap. Tightening the cap will not make the CHECK ENGINE warning light turn off immediately. It may take several driving trips. If the light does not turn off, take your vehicle to your authorized SUBARU dealer immediately.

▼ **If the light is blinking**

If the light is blinking while driving, an engine misfire condition has been detected which may damage the emission control system.

To prevent serious damage to the emission control system, you should do the following.

- Reduce vehicle speed.
- Avoid hard acceleration.
- Avoid steep uphill grades.
- Reduce the amount of cargo, if possible.

The CHECK ENGINE warning light may stop blinking and illuminate steadily after

several driving trips. You should have your vehicle checked by an authorized SUBARU dealer immediately.

■ **Coolant temperature low indicator light/Coolant temperature high warning light**



 **CAUTION**

- **After turning the ignition switch to the "ON" position, if this indicator light/warning light behaves in any of the following ways, the electrical system may be malfunctioning. Contact your SUBARU dealer immediately for an inspection.**
 - **It remains blinking in RED.**
 - **It remains illuminated in RED for more than 2 seconds.**
 - **It remains blinking in RED and BLUE alternately.**
- **While driving, if this indicator light/warning light behaves in any of the following ways, take the specified appropriate measure listed below.**

- **Blinking or illuminated in RED:**
Safely stop the vehicle as soon as possible, and refer to the emergency steps to take in the case of engine overheating. After that, have the system checked by your nearest SUBARU dealer. Refer to "Engine overheating" 9-13.
- **Blinking in RED and BLUE alternately:**
The electrical system may be malfunctioning. Contact your SUBARU dealer for an inspection.

This coolant temperature low indicator light/coolant temperature high warning light has the following three functions.

- Illumination in **BLUE** indicates insufficient warming up of the engine
- Blinking in **RED** indicates that the engine is close to overheating
- Illumination in **RED** indicates overheating condition of the engine

For a system check, this indicator light/warning light illuminates in **RED** for approximately 2 seconds when the ignition switch is turned to the "ON" position.

After that, this indicator light/warning light changes to **BLUE** and maintains illumination in **BLUE**. This **BLUE** illuminated light turns off when the engine is warmed up sufficiently.

If the engine coolant temperature increases over the specified range, the indicator light/warning light blinks in **RED**. At this time, the engine is close to overheating.

If the engine coolant temperature increases further, the indicator light/warning light illuminates in **RED** continuously. At this time, the engine may be overheating.

When the indicator light/warning light blinks in **RED** or illuminates in **RED**, safely stop the vehicle as soon as possible, and refer to the emergency steps to take in the case of engine overheating. Refer to "Engine overheating" ¶9-13. After that, have the system checked by your nearest SUBARU dealer.

Also, if the indicator light/warning light often blinks in **RED**, the electrical system may be malfunctioning. Contact your SUBARU dealer for an inspection.

NOTE

If the engine is restarted after a certain driving condition, this indicator light/

warning light may illuminate in RED. However, this is not a malfunction if the indicator light/warning light turns off after a short time.

■ Charge warning light



If this light illuminates when the engine is running, it may indicate that the charging system is not working properly.

If the light illuminates while driving or does not turn off after the engine starts, stop the engine at the first safe opportunity and check the alternator belt. If the belt is loose, broken or if the belt is in good condition but the light remains illuminated, contact your nearest SUBARU dealer immediately.

■ Oil pressure warning light



If this light illuminates when the engine is running, it may indicate that the engine oil pressure is low and the lubricating system is not working properly.

If the light illuminates while driving or does not turn off after the engine starts, stop the engine at the first safe opportunity and check the engine oil level. If the oil level is low, add oil immediately. If the engine oil is at the proper level but the light remains

illuminated, contact your nearest SUBARU dealer immediately.

For details about checking the engine oil level or adding the engine oil, refer to "Engine oil" ¶11-8.



CAUTION

Do not operate the engine with the oil pressure warning light illuminated. This may cause serious engine damage.

■ Engine low oil level warning light



This light illuminates when the engine oil level decreases to the lower limit.

If the engine low oil level warning light illuminates while driving, park the vehicle in a safe and level location, and then check the engine oil level. When the engine oil level is not within the normal range, refill with engine oil. Refer to "Engine oil" ¶11-8.

If the warning light does not turn off after refilling the engine oil, or the warning light illuminates even though the engine oil level is within the normal range, have the vehicle checked by a SUBARU dealer.

NOTE

- The warning light may stay illuminated when the engine is started straight after topping up or changing the engine oil. In such cases, park the vehicle on a level surface and wait for more than a minute until the oil level settles, after which the warning light will turn off.
- The warning light may illuminate temporarily in the following conditions because a low oil level may be detected as a result of significant oil movement in the engine.
 - when the vehicle is considerably inclined on an uphill or steep slope
 - when the vehicle has continuously accelerated and decelerated
 - when the vehicle is continuously turned
 - when the vehicle is driven on a road that alternates continuously between uphill and downhill

■ Windshield washer fluid warning light

This light illuminates when the fluid level in the windshield washer fluid tank decreases to the lower limit (approximately 0.6 US qt, 0.6 liter, 0.5 Imp qt).

■ AT OIL TEMP warning light (CVT models)
AT OIL TEMP

If this light illuminates when the engine is running, it may indicate that the transmission fluid temperature is too hot.

If the light illuminates while driving, immediately stop the vehicle in a safe place and let the engine idle until the warning light turns off.

▼ Transmission control system warning

If the "AT OIL TEMP" warning light flashes after the engine has started, it may indicate that the transmission control system is not working properly. Contact your nearest SUBARU dealer for service immediately.

■ Low tire pressure warning light (U.S.-spec. models)

When the ignition switch is turned to the "ON" position, the low tire pressure warning light will illuminate for approximately 2 seconds to check that the tire pressure monitoring system (TPMS) is functioning properly. If there is no problem and all tires are properly inflated, the light will turn off. Each tire, including the spare (if provided),

should be checked monthly when cold and inflated to the inflation pressure recommended by the vehicle manufacturer on the vehicle placard or tire inflation pressure label. (If your vehicle has tires of a different size than the size indicated on the vehicle placard or tire inflation pressure label, you should determine the proper tire inflation pressure for those tires.)

As an added safety feature, your vehicle has been equipped with a tire pressure monitoring system (TPMS) that illuminates a low tire pressure telltale when one or more of your tires is significantly under-inflated. Accordingly, when the low tire pressure telltale illuminates, you should stop and check your tires as soon as possible, and inflate them to the proper pressure. Driving on a significantly under-inflated tire causes the tire to overheat and can lead to tire failure. Under-inflation also reduces fuel efficiency and tire tread life, and may affect the vehicle's handling and stopping ability.

Please note that the TPMS is not a substitute for proper tire maintenance, and it is the driver's responsibility to maintain correct tire pressure, even if under-inflation has not reached the level to trigger illumination of the TPMS low tire pressure telltale.

Your vehicle has also been equipped with a TPMS malfunction indicator to indicate when the system is not operating properly. The TPMS malfunction indicator is combined with the low tire pressure telltale. When the system detects a malfunction, the telltale will flash for approximately one minute and then remain continuously illuminated. This sequence will continue upon subsequent vehicle start-ups as long as the malfunction exists. When the malfunction indicator is illuminated, the system may not be able to detect or signal low tire pressure as intended. TPMS malfunctions may occur for a variety of reasons, including the installation of replacement or alternate tires or wheels on the vehicle that prevent the TPMS from functioning properly. Always check the TPMS malfunction telltale after replacing one or more tires or wheels on your vehicle to ensure that the replacement or alternate tires and wheels allow the TPMS to continue to function properly.

Should the warning light illuminate steadily after blinking for approximately one minute, have the system inspected by your nearest SUBARU dealer as soon as possible.

**WARNING**

If this light does not illuminate briefly after the ignition switch is turned ON or the light illuminates steadily after blinking for approximately one minute, you should have your Tire Pressure Monitoring System checked at a SUBARU dealer as soon as possible.

If this light illuminates while driving, never brake suddenly and keep driving straight ahead while gradually reducing speed. Then slowly pull off the road to a safe place. Otherwise an accident involving serious vehicle damage and serious personal injury could occur.

If this light still illuminates while driving after adjusting the tire pressure, a tire may have significant damage and a fast leak that causes the tire to lose air rapidly. If you have a flat tire, replace it with a spare tire as soon as possible.

When a spare tire is mounted or a wheel rim is replaced without the original pressure sensor/transmitter being transferred, the Low tire pressure warning light will illuminate steadily after blinking for approximately one minute. This indicates

the TPMS is unable to monitor all four road wheels. Contact your SUBARU dealer as soon as possible for tire and sensor replacement and/or system resetting.

If the light illuminates steadily after blinking for approximately one minute, promptly contact a SUBARU dealer to have the system inspected.

**CAUTION**

The tire pressure monitoring system is NOT a substitute for manually checking tire pressure. The tire pressure should be checked periodically (at least monthly) using a tire gauge. After any change to tire pressure(s), the tire pressure monitoring system will not re-check tire inflation pressures until the vehicle is first driven more than 20 mph (32 km/h). After adjusting the tire pressures, increase the vehicle speed to at least 20 mph (32 km/h) to start the TPMS re-checking of the tire inflation pressures. If the tire pressures are now above the severe low pressure threshold, the low tire pressure warning light should turn off a few minutes later. Therefore, be sure to install the specified size for

the front and rear tires.

■ ABS warning light ABS / (ABS)

CAUTION

- If any of the following conditions occur, we recommend that you have the ABS repaired at the first available opportunity by your SUBARU dealer.
 - The warning light does not illuminate when the ignition switch is turned to the “ON” position.
 - The warning light illuminates when the ignition switch is turned to the “ON” position, but it does not turn off even after the vehicle is started.
 - The warning light illuminates during driving.
- When the warning light is on (and the brake system warning light is off), the ABS function shuts down. However, the conventional brake system continues to operate normally.

The ABS warning light illuminates together with the brake system warning light

if the EBD system malfunctions. For further details of the EBD system malfunction warning, refer to “Electronic Brake Force Distribution (EBD) system warning” 3-22.

NOTE

If the warning light behavior is as described in the following conditions, the ABS may be considered normal.

- The warning light illuminates when the ignition switch is turned to the “ON” position and turns off approximately 2 seconds after the engine has started.
- The warning light illuminates right after the engine is started but turns off immediately, remaining off.
- The warning light remains illuminated after the engine has been started, but it turns off while driving.
- The warning light illuminates during driving, but it turns off immediately and remains off.

When driving with an insufficient battery voltage such as when the engine is jump started, the ABS warning light may illuminate. This is due to the low battery voltage and does not indicate a malfunction. When the battery becomes fully charged, the light will turn off.

■ Brake system warning light (red) BRAKE / (ⓘ)

This light illuminates with the parking brake applied while the ignition switch is in the “ON” position. It turns off when the parking brake is fully released.

WARNING

- Driving with the brake system warning light on is dangerous. This indicates your brake system may not be working properly. If the light remains illuminated, have the brakes inspected by a SUBARU dealer immediately.
- If at all in doubt about whether the brakes are operating properly, do not drive the vehicle. Have your vehicle towed to the nearest SUBARU dealer for repair.



The brake system warning light has the following functions.

▼ Brake fluid level warning BRAKE / (ⓘ)



This light illuminates when the brake fluid level has dropped to near the “MIN” level of the brake fluid reservoir with the ignition switch in the “ON” position and with the parking brake fully released.

If the brake system warning light should illuminate while driving (with the parking brake fully released and with the ignition switch positioned in "ON"), it could be an indication of leaking of brake fluid or worn brake pads. If this occurs, immediately stop the vehicle at the nearest safe location and check the brake fluid level. If the fluid level is below the "MIN" mark in the reservoir, do not drive the vehicle. Have the vehicle towed to the nearest SUBARU dealer for repair.

▼ Electronic Brake Force Distribution (EBD) system warning

The EBD system may be malfunctioning if the brake system warning light , Vehicle Dynamics Control warning light  and ABS warning light  illuminate simultaneously during driving.

Even if the EBD system fails, the conventional braking system will still function. However, the rear wheels will be more prone to locking when the brakes are applied harder than usual and the vehicle's motion may therefore become somewhat harder to control.

If the brake system warning light , Vehicle Dynamics Control warning light  and ABS warning light  illuminate simultaneously, take the following steps.

1. Stop the vehicle in the nearest safe,

flat location.

2. Shut down the engine, apply the parking brake and then restart it.
3. Fully release the parking brake.
4. Even if all the warning lights do not come back on, the EBD system may have a possible malfunction. Drive carefully to the nearest SUBARU dealer and have the system inspected.
5. If all the warning lights stay illuminated or come back on after approximately 2 seconds, shut down the engine, apply the parking brake and check the brake fluid level.

- If the brake fluid level is not below the "MIN" mark, the EBD system may be malfunctioning. Drive carefully to the nearest SUBARU dealer and have the system inspected.

- If the brake fluid level is below the "MIN" mark, DO NOT drive the vehicle. Instead, have the vehicle towed to the nearest SUBARU dealer for repair.

▼ Vacuum pressure system warning

The brake system warning light  will illuminate when the vacuum pressure sensor is malfunctioning or brake booster pressure is decreasing.

If the brake warning light continues to illuminate for several minutes after starting

the engine, there may be a malfunction in the vacuum system. In this case, drive the vehicle carefully and have the system inspected by a SUBARU dealer.

■ Low fuel warning light



The low fuel warning light illuminates when the tank is nearly empty, at approximately 2 US gal (7.5 liters, 1.65 Imp gal). It only operates when the ignition switch is in the "ON" position.



CAUTION

Promptly put fuel in the tank whenever the low fuel warning light illuminates. Engine misfires as a result of an empty tank could cause damage to the engine.

NOTE

This light does not turn off unless the tank is replenished up to an internal fuel quantity of approximately 2.1 US gal (8.1 liters, 1.8 Imp gal).

■ Hill start assist warning light/Hill start assist OFF indicator light

▼ Hill start assist warning light

While the engine is running, if there are any malfunctions in the Hill start assist system, the warning light will illuminate.



WARNING

When the Hill start assist warning light illuminates, have the vehicle inspected at an authorized SUBARU dealer.

▼ Hill start assist OFF indicator light

While the Hill start assist system is deactivated, the Hill start assist OFF indicator light illuminates continuously to inform the driver that the Hill start assist system is not operational.

■ Door open warning light

The warning light illuminates if any door, the rear gate (5-door models) or the trunk lid (sedan) is not fully closed. This function is effective even if the ignition switch is in the "LOCK"/"OFF" or "ACC" position, or

the key is removed from the ignition switch.

Always make sure this light is not illuminated before you start to drive.

■ All-Wheel Drive warning light (CVT models) **AWD**

This light blinks if the vehicle is driven with tires of differing diameters fitted on the wheels or with an excessively low air pressure in any of the tires.



WARNING

If the AWD warning light flashes, promptly park in a safe location then check whether all four tires are the same diameter and whether any of the tires has a puncture or has lost air pressure for some other reason. Continuing to drive with the AWD warning light flashing can lead to powertrain damage.

NOTE

If the temporary spare tire is used, the AWD warning light may flash. Use of the temporary spare tire should therefore be restricted to the minimum time necessary. Replace the temporary spare tire with a conventional tire as

soon as possible.

■ Power steering warning light

This warning light illuminates when the ignition switch is turned to the "ON" position and turns off after the engine has started. This indicates that the warning system is working properly.

While the engine is running, this warning light illuminates when a malfunction has been detected in the electric power steering system.



CAUTION

When the power steering warning light is illuminated, there may be more resistance when the steering wheel is operated. Drive carefully to the nearest SUBARU dealer and have the vehicle inspected immediately.

NOTE

If the steering wheel is operated in the following ways, the power steering control system may temporarily limit the power assist in order to prevent the system components, such as the con-

trol computer and drive motor, from overheating.

- The steering wheel is operated frequently and turned sharply while the vehicle is maneuvered at extremely low speeds, such as while frequently turning the steering wheel during parallel parking.
- The steering wheel remains in the fully turned position for a long period of time.

At this time, there will be more resistance when steering. However this is not a malfunction. Normal steering force will be restored after the steering wheel is not operated for a while and the power steering control system has an opportunity to cool down. However, if the power steering is operated in a non-standard way which causes power assist limitation to occur too frequently, that may result in a malfunction of the power steering control system.

■ Vehicle Dynamics Control warning light/ Vehicle Dynamics Control operation indicator light



▼ Vehicle Dynamics Control warning light



CAUTION

The Vehicle Dynamics Control system provides its ABS control through the electrical circuit of the ABS. Accordingly, if the ABS is inoperative, the Vehicle Dynamics Control system becomes unable to provide ABS control. As a result, the Vehicle Dynamics Control system also becomes inoperative, causing the warning light to illuminate. Although both the Vehicle Dynamics Control system and ABS are inoperative in this case, the ordinary functions of the brake system are still available. You will be safe while driving with this condition, but drive carefully and have your vehicle checked at a SUBARU dealer as soon as possible.

NOTE

- If the electrical circuit of the Vehicle Dynamics Control system itself malfunctions, the warning light only illuminates. At this time, the ABS (Anti-lock Brake System) remains fully operational.
- The warning light illuminates when the electronic control system of the ABS/Vehicle Dynamics Control system malfunctions.

The Vehicle Dynamics Control system is probably inoperative under any of the following conditions. Have your vehicle checked at a SUBARU dealer immediately.

- The warning light does not illuminate when the ignition switch is turned to the "ON" position.
- The warning light illuminates while the vehicle is running.

NOTE

If the warning light behavior is as described in the following examples, the Vehicle Dynamics Control system may be considered normal.

- The warning light illuminates when the ignition switch is turned to the "ON" position and turns off approximately 2 seconds after the engine has started.

- The warning light illuminates right after the engine is started but turns off immediately, remaining off.
- The warning light illuminates after the engine has started and turns off while the vehicle is subsequently being driven.
- The warning light illuminates during driving, but it turns off immediately and remains off.
- The warning light illuminates when the engine has stalled and continues to illuminate after the engine has been restarted. However, it will turn off once the vehicle starts moving.

▼ Vehicle Dynamics Control operation indicator light

The indicator light flashes during activation of the skid suppression function and during activation of the traction control function.

NOTE

- The light may remain illuminated for a short period of time after the engine has been started, especially in cold weather. This does not indicate the existence of a problem. The light should turn off as soon as the engine has warmed up.
- The indicator light illuminates when the engine has developed a problem

and the CHECK ENGINE warning light/malfunction indicator light is on.

The Vehicle Dynamics Control system is probably malfunctioning under the following condition. Have your vehicle checked at a SUBARU dealer as soon as possible.

- The light does not turn off even after the lapse of several minutes (the engine has warmed up) after the engine has started.

■ Vehicle Dynamics Control OFF indicator light



The light illuminates when the Vehicle Dynamics Control OFF switch is pressed to deactivate the Vehicle Dynamics Control system.

The Vehicle Dynamics Control system is probably malfunctioning under any of the following conditions. Have your vehicle checked at a SUBARU dealer immediately.

- The light does not illuminate when the ignition switch is turned to the "ON" position.
- The light does not turn off even once several seconds have elapsed after the ignition switch has been turned to the "ON" position.

■ Warning chimes and warning indicator of the keyless access with push-button start system (if equipped)

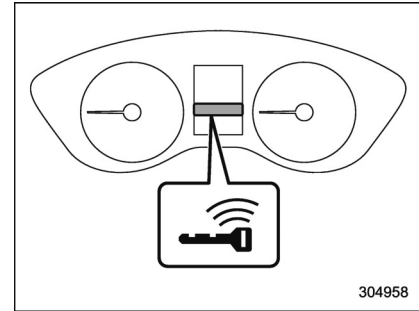

Access key warning indicator

The keyless access with push-button start system sounds a warning chime and flashes the access key warning indicator on the combination meter in order to minimize improper operations and help protect your vehicle from theft.

When the warning chime sounds and/or the warning indicator flashes, take the appropriate action.

 **WARNING**

Never drive the vehicle if the indicator on the push-button ignition switch is flashing in green when starting the engine. This indicates the status that the steering wheel is not released and could result in an accident involving serious injury or death.

 **CAUTION**

- When starting the engine again after the operation indicator on the push-button ignition switch flashes in green, if the operation indicator is still flashing in green, there could be a steering lock malfunction. Contact your SUBARU dealer as soon as possible.
- When the operation indicator on the push-button ignition switch flashes in orange, contact a SUBARU dealer immediately.

NOTE

- When doors are not locked because the access key fob is left inside the trunk, you cannot open the trunk lid by pushing the trunk opener button on the trunk lid. Pull the trunk lid release lever upward to open the trunk lid. Refer to “To open the trunk lid from inside” 2-33.
- Do not leave the access key fob inside the trunk. Depending on the status of the access key fob and situation, the trunk lockout protect function may not operate. Make sure that you carry the access key fob, and close the trunk lid.
- Even when the access key fob is within the operating ranges inside the vehicle, the access key warning for engine start may be provided depending on the status of the access key fob and the environmental conditions.
- When the access key fob is taken out of the vehicle through an open window, the access key fob takeout warning or passenger access key fob takeout warning will not be provided.

▼ List of warnings

 **CAUTION**

When any of the following warnings occurs even if the access key warning indicator does not appear, take the appropriate action.

Inside warning chime	Outside warning chime	Operation indicator on push-button ignition switch	Status	Action
Ding, ding ... (intermittent)	—	—	The driver's door was opened while the push-button ignition switch is "ACC" (in CVT models, when the select lever is in the "P" position).	Switch the push-button ignition switch to "OFF", or close the driver's door. *When exiting the vehicle, be sure to switch the push-button ignition switch to "OFF".
			The push-button ignition switch was switched to "OFF" while the driver's door is open.	Close the driver's door.
Ding	Short beep (2 seconds)	—	Lockout warning: An attempt was made to lock all doors while the access key fob is left inside the vehicle.	Take out the access key fob from the vehicle, and lock the doors. *The doors cannot be locked while the access key fob is inside the vehicle. *A chirp sound will be heard, and all doors will be unlocked.
—	Short beep (2 seconds)	—	Trunk lockout warning: The trunk was closed with the access key fob in it while all doors are locked (or during the automatic lock time period) (sedan).	Take out the access key fob from the trunk, and close the trunk. *By pressing the trunk opener button after this warning chime sounds, the trunk can be unlocked.
			Access key fob lock-in warning: The door lock sensor was touched while the push-button ignition switch is "OFF" and the access key fob is inside the vehicle.	Take out the access key fob from the vehicle, and lock the doors. *If the access key fob is inside the vehicle, the doors cannot be locked.
—	Beep, beep, beep, beep, beep (5 times)	—	Door ajar warning: The door lock sensor is touched while the ignition switch is in the "OFF" position and one of the doors including the rear gate is opened.	Close the doors securely and lock them. *If one of the doors including the rear gate is opened, the doors cannot be locked.

3-28 Instruments and controls/Warning and indicator

Inside warning chime	Outside warning chime	Operation indicator on push-button ignition switch	Status	Action
Ding	Long beep (60 seconds max.)	—	Power warning: The door lock sensor was touched while carrying the access key fob, the push-button ignition switch is in a position other than "OFF" (in CVT models, when the select lever is in the "P" position).	Return the access key fob inside the vehicle, or switch the push-button ignition switch to "OFF". *If the push-button ignition switch is not switched to "OFF", the doors cannot be locked.
Ding, ding ... (7 seconds)	—	—	Access key warning: The vehicle was driven while the access key fob is not inside the vehicle.	Carry the access key fob, and drive the vehicle.
Ding	—	—	Access key warning for engine start: The push-button ignition switch was pressed while the access key fob is not inside the vehicle.	Carry the access key fob, and press the push-button ignition switch.
Ding	Beep, beep, beep (3 times)	—	Access key takeout warning: The driver exited the vehicle with the access key fob and closed the driver's door while the push-button ignition switch is in a position other than "OFF" (in CVT models, when the select lever is in the "P" position).	Switch the push-button ignition switch to "OFF", and get out of the vehicle.
Ding	Beep, beep, beep (3 times)	—	Passenger access key takeout warning: A fellow passenger exited the vehicle with the access key fob and closed a door other than the driver's door while the push-button ignition switch is in a position other than "OFF".	Return the access key fob to inside the vehicle, or switch the push-button ignition switch to "OFF".

Inside warning chime	Outside warning chime	Operation indicator on push-button ignition switch	Status	Action
Long beep (continuous)	Long beep (continuous)	—	Access key takeout without P position warning (CVT models): The driver exited the vehicle with the access key fob and closed the driver's door while the push-button ignition switch is in a position other than "OFF" and the select lever is in a position other than the "P" position.	Shift the select lever to the "P" position, switch the push-button ignition switch to "OFF" and exit the vehicle.
Long beep (continuous)	—	—	Select lever position warning (CVT models): The engine is turned off by pressing the push-button ignition switch and the select lever is in a position other than the "P" position.	Start the engine, shift the select lever to the "P" position, switch the push-button ignition switch to "OFF" and exit the vehicle.
Long beep (continuous)	—	—	Select lever position warning (CVT models): The driver's door was opened while the push-button ignition switch is in a position other than "OFF" and the select lever is in a position other than the "P" position.	Shift the select lever to the "P" position, switch the push-button ignition switch to "OFF" and exit the vehicle.
Ding	—	—	The battery of the access key fob is low.	Replace the battery of the access key fob.
Ding	—	Flashes in green (15 seconds max.)	Steering lock warning: The engine start procedure was performed, but the steering is still locked.	While turning the steering wheel right and left lightly, depress the brake pedal and press the push-button ignition switch.
Ding	—	Flashes in orange (15 seconds max.)	System malfunction warning: A malfunction was detected in the power system or steering lock.	Contact a SUBARU dealer immediately and have the vehicle inspected.

■ Security indicator light

This indicator light shows the status of the alarm system. It also indicates operation of the immobilizer system.

▼ Alarm system

It blinks to show the driver the operational status of the alarm system. For detailed information, refer to “Alarm system” 2-26.

▼ Immobilizer system

The security indicator light starts blinking in the following conditions.

For models with “keyless access with push-button start system”:

- Immediately after the push-button ignition switch is turned to the “OFF” position.
- Immediately after the driver’s door is opened or closed when all of the following conditions are met.
 - The push-button ignition switch is in the “ON” or “ACC” position.
 - The access key fob is outside the vehicle.
 - The engine is not running.

In the event that an unauthorized key is used (for example, the key is unregistered or the ID code does not match), the power is not switched to “ON” and the security indicator light continues blinking.

For models without “keyless access with push-button start system”:

- Approximately 60 seconds after the ignition switch is turned from the “ON” position to the “ACC” or “LOCK” position.
- Immediately after the key is pulled out.

If the indicator light does not blink in the above conditions, it may indicate that immobilizer system may be malfunctioning. Contact your nearest SUBARU dealer immediately.

In the event that an unauthorized key (for example, an unauthorized duplicate) is used to start the engine, the security indicator light illuminates. For details about the immobilizer system, refer to “Immobilizer” 2-17.

NOTE

- **The security indicator light remains off in the following conditions. It means that the matching of the ID code is completed and the immobilizer system is deactivated, and it does not indicate a malfunction.**

Models with “keyless access with push-button start system”:

- while the engine is running
- the push-button ignition switch has been turned to the “ON” or

“ACC” position and the driver’s door has not been opened or closed

Models without “keyless access with push-button start system”:

- while the engine is running
- for approximately 60 seconds after the ignition switch is turned from the “ON” position to the “ACC” or “LOCK” position
- when the ignition switch is in the “ON” position.

- **Even if a malfunction occurs, such as the security indicator light flashes irregularly, it will not affect the functionality of the immobilizer system.**

■ Select lever/gear position indicator (CVT models)

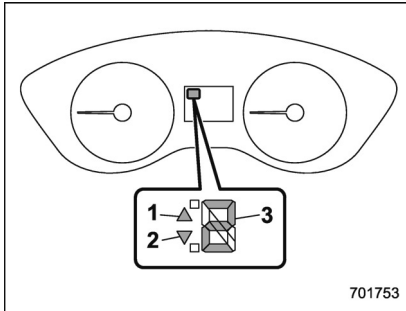

Type A

- 1) Upshift indicator
- 2) Downshift indicator
- 3) Select lever/gear position indicator

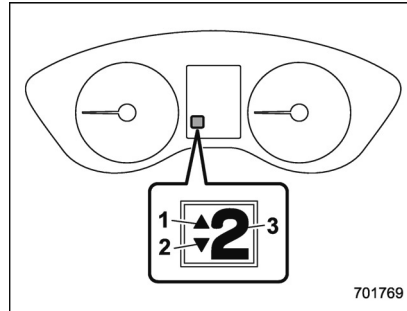

Type B

- 1) Upshift indicator
- 2) Downshift indicator
- 3) Select lever/gear position indicator

This indicator shows the position of the select lever.

For models with manual mode, when the manual mode is selected, the gear position indicator (which shows the current gear selection) and the upshift/downshift indicator light up. Refer to "Continuously variable transmission" ¶7-23.

■ Turn signal indicator lights ← →

These lights show the operation of the turn signal or lane change signal.

If the indicator lights do not blink or blink

rapidly, the turn signal bulb may be burned out. Replace the bulb as soon as possible. Refer to "Replacing bulbs" ¶11-37.

■ High beam indicator light

This light shows that the headlights are in the high beam mode.

This indicator light also illuminates when the headlight flasher is operated.

■ High beam assist indicator light (green) (if equipped)

This light illuminates when the high beam assist function is activated. For details about the high beam assist function, refer to "High beam assist function" ¶3-68.

■ High beam assist warning indicator (yellow) (if equipped)

This warning indicator appears when the high beam assist function malfunctions. When this warning indicator appears, have your vehicle inspected by your SUBARU dealer.

■ **Cruise control indicator light (if equipped)**



This light illuminates when the cruise control main button is pressed to activate the cruise control function. For details, refer to "To set cruise control" 7-44.

If this light blinks, do not use the cruise control. In addition, if it blinks frequently, contact your SUBARU dealer for an inspection.



CAUTION

If the CHECK ENGINE warning light/malfunction indicator light illuminates, the cruise control indicator light flashes at the same time. At this time, avoid driving at high speed and have your vehicle inspected at a SUBARU dealer as soon as possible.

■ **Cruise control set indicator light (if equipped)**



This light illuminates when vehicle speed has been set to use the cruise control function. Refer to "To set cruise control" 7-44.

■ **Automatic headlight beam leveler warning light (models with LED headlights)**



This light illuminates when the automatic headlight beam leveler does not operate normally.

If this light illuminates during driving, have your vehicle inspected at your SUBARU dealer.

■ **LED headlight warning light (models with LED headlights)**



This light illuminates if the LED headlights malfunction. Have your vehicle inspected at a SUBARU dealer as soon as possible.

■ **Steering Responsive Headlight warning light/Steering Responsive Headlight OFF indicator light (if equipped)**



This light illuminates when the Steering Responsive Headlight OFF switch is pressed to deactivate the Steering Responsive Headlight. Also, the light flashes when a malfunction occurs in the Steering Responsive Headlight. Refer to "Steering Responsive Headlight (SRH)" 3-72.

■ **Front fog light indicator light (if equipped)**



This indicator light illuminates while the front fog lights are illuminated.

■ **Headlight indicator light (if equipped)**



This indicator light illuminates under the following conditions.

- when the light switch is turned to the "DOE" or "DO" position
- when the light control switch is in the "AUTO" position and the headlights illuminate automatically

■ **Steering responsive fog lights warning indicator/Steering responsive fog lights OFF indicator (if equipped)**



NOTE

For details about the steering responsive fog lights system, refer to "Steering responsive fog lights system" 3-73.

▼ Steering responsive fog lights warning indicator

This indicator appears when the steering responsive fog lights system malfunctions. When this indicator appears while the system is activated, contact your SUBARU dealer for an inspection.

▼ Steering responsive fog lights OFF indicator

This indicator appears when the steering responsive fog lights system is deactivated. This indicator disappears when the system is activated.

■ BSD/RCTA warning indicator (if equipped)

This warning indicator appears when the BSD/RCTA is malfunctioning. In this case the BSD/RCTA warning indicator will be shown on the combination meter display (color LCD). When this indicator appears, have your vehicle inspected by your SUBARU dealer as soon as possible.

■ BSD/RCTA OFF indicator (if equipped)

The indicator appears when the BSD/RCTA OFF switch is pressed to deactivate the BSD/RCTA. In this case the BSD/RCTA OFF indicator will be shown on the

combination meter display (color LCD). For details, refer to "BSD/RCTA" 7-48.

■ RAB warning indicator (if equipped) **RAB**

This indicator illuminates if the Reverse Automatic Braking System malfunctions. Refer to "Reverse Automatic Braking System" 7-57.

■ RAB OFF indicator light (if equipped) **RAB OFF**

This indicator illuminates when the Reverse Automatic Braking System is turned OFF, or when the Reverse Automatic Braking System is suspended temporarily. Refer to "Reverse Automatic Braking System" 7-57.

■ Icy road surface warning indicator (if equipped)

When the outside temperature is 37°F (3°C) or less, the icy road surface warning will illuminate to inform the driver that the road surface may be frozen.

NOTE

- The outside temperature indicator shows the temperature in the area around the sensor. Therefore, the temperature indication may differ from the actual outside air temperature.
- The icy road surface warning screen should be treated only as a guide. Be sure to check the condition of the road surface before driving.
- Once the icy road surface warning screen appears, it will not disappear unless the outside temperature has increased to 41°F (5°C) or higher.

Combination meter display (color LCD) (if equipped)

WARNING

Always pay adequate attention to safe driving when operating the combination meter display (color LCD) while the vehicle is in motion. When operation of the combination meter display (color LCD) interferes with your ability to concentrate on driving, stop the vehicle before performing operations on the screen. Also, do not concentrate on the display while driving. Doing so may cause you to look away from the road and could result in an accident.

Various information will be shown on the combination meter display (color LCD). Also, a warning message will appear on the display if a malfunction, etc. is detected. In addition, several settings for the displayed content can be performed.

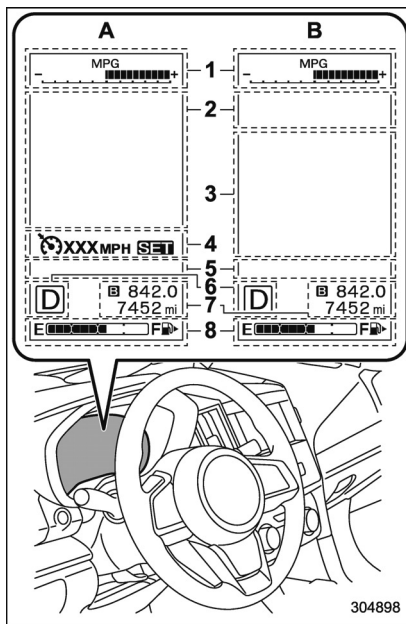

Combination meter display (color LCD)

- 1) ECO gauge
- 2) Warning screen (refer to "Warning screen" ¶3-36.)/Basic screen (refer to "Basic screens" ¶3-37.)
- 3) EyeSight screen
- 4) Cruise control information display

- 5) Telltale screen (refer to "Telltale screen" ¶3-36.)
 - 6) Select lever/gear position indicator (refer to "Select lever/gear position indicator (CVT models)" ¶3-31.)
 - 7) Odometer (refer to "Odometer" ¶3-9.)/
double trip meter (refer to "Double trip meter" ¶3-9.)
 - 8) Fuel gauge (refer to "Fuel gauge" ¶3-10.)
- A: Deactivating the Eyesight system or models without the Eyesight system
B: Activating the Eyesight system

304898

■ Basic operation

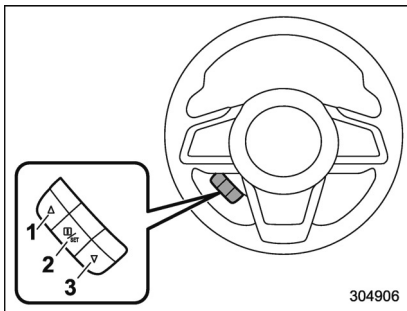

Control switch

- 1) ▲ (Up)
- 2) **I**/SET (enter)
- 3) ▼ (Down)

By operating “▲” or “▼” of the control switch, the screens and selection items can be switched. When the “**I**/SET” switch is pulled toward you, the item can be selected and set.

If there are some useful messages, such as vehicle information, warning information, etc., they will interrupt the current screen, and appear on the display accompanied by a beep. If such a screen is displayed, take proper action according to the message shown on the screen.

The warning screen will return to the

original screen after a few seconds. While the “**I**” information reminder is shown on the display, it may be possible to display the warning screen again. To recall the message marked with “**I**” on the display, pull the “**I**/SET” switch on the steering wheel toward you.

NOTE

When the multi-function display (color LCD) is set to the setting screen, the combination meter display (color LCD) cannot be controlled pressing on the “▲”, “▼” and “**I**/SET” on the control switch.

■ Welcome screen and Good-bye screen

When the driver’s door is opened and closed after unlocking the door, the welcome screen will appear on the combination meter display (color LCD) for approximately 20 seconds.

When the ignition switch is turned to the “LOCK”/“OFF” position, the combination meter display (color LCD) gradually turns off (Good-bye screen).

NOTE

- Once the welcome screen appears, it takes a certain period of time to display it again.
- If the ignition switch is operated after unlocking the driver’s door, the welcome screen will not appear even when the driver’s door is opened and closed.
- The welcome screen will disappear when you lock the driver’s door by using the remote keyless entry system (all models) or the keyless access function (if equipped) while the welcome screen is displayed.
- The welcome screen including the multi-function display (color LCD) (if equipped) and the audio/navigation unit can be set to on or off. For details, refer to “Welcome Screen” 3-42.

■ Warning screen



Example of warning

If there is a warning message or a maintenance notification, it will appear on this screen. Take the appropriate actions based on the messages indicated.

■ Telltale screen

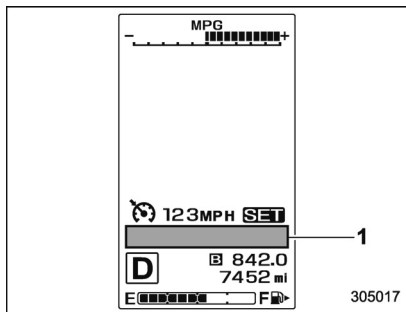

1) Telltale screen

When the corresponding situation occurs, the following telltales will be displayed on the telltale screen.

NOTE

When there is warning information to display, it will be displayed in five warning indicators, starting on the left in ascending order of severity. If there are six or more warning information displayed, pull the "I/SET" switch and check the item.

Mark	Name	Page
	Door open indicator	3-23
	LED headlight warning indicator (if equipped)	3-32
	High beam assist indicator (green) (if equipped)	3-31
SRH OFF	Steering Responsive Headlight warning light (if equipped)	3-32
	Engine low oil level warning indicator	3-18
RAB	RAB warning indicator (if equipped)	3-33
RAB OFF	RAB OFF indicator (if equipped)	3-33
	BSD/RCTA warning indicator (if equipped)	3-33
	BSD/RCTA OFF indicator (if equipped)	3-33
	Automatic headlight beam leveler system malfunction warning (models with LED headlights)	3-32

Mark	Name	Page
SRF OFF	Steering responsive fog lights OFF indicator (if equipped)	3-32
	High beam assist warning indicator (yellow) (if equipped)	3-31
	Windshield washer fluid warning indicator	3-19
	Icy road surface warning indicator	3-33

■ Basic screens

By operating the “▲” or “▼” switch on the steering wheel, you can change the screen that is always displayed.

Average fuel consumption screen:

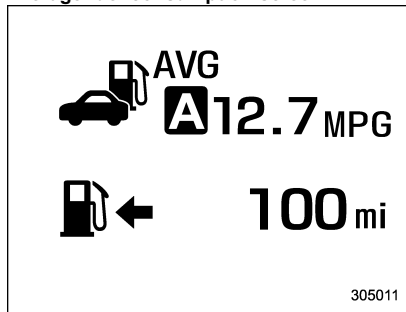

: Average fuel consumption

: Driving range on remaining fuel

This screen displays the average rate of fuel consumption since the trip meter was last reset.

Current fuel consumption screen:

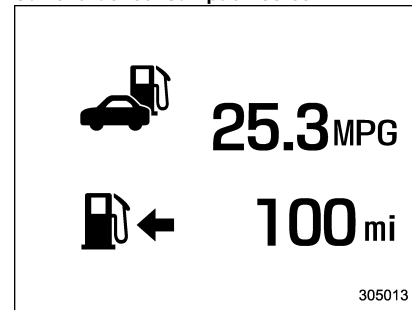



: Current fuel consumption

: Driving range on remaining fuel

This screen displays the rate of fuel consumption at the present moment.

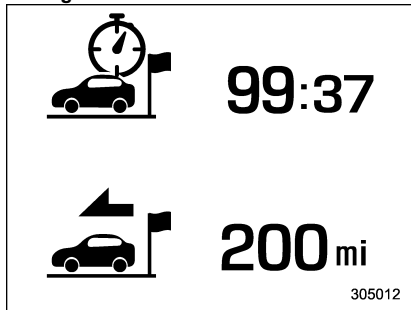
Driving information screen:



: Journey time

: Journey distance

This screen displays the journey time (the time that has elapsed since the ignition switch was turned to the "ON" position) and journey distance (the distance that has been driven since the ignition switch was turned to the "ON" position).

Digital speed screen:

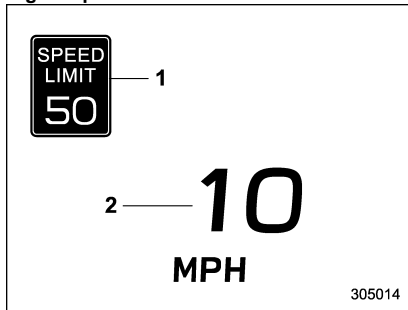

1) Speed limit (if equipped)

2) Vehicle speed

This screen displays the current vehicle speed.

TPMS screen (U.S.-spec. models):

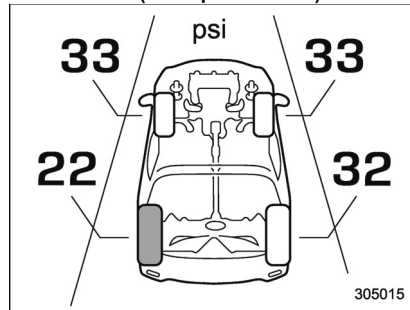

This screen displays each tire pressure.

When a tire is deflated, the deflated tire and the tire pressure will be displayed on the screen in yellow.

NOTE

The tire pressure values are displayed several minutes after driving.

Menu screen entering screen:

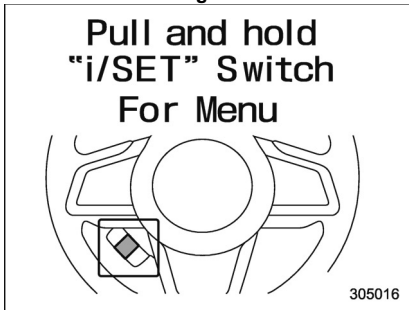

While this screen is selected, pull and hold the “i/SET” switch to enter the menu screen.

■ Menu screens

Pull and hold the “i/SET” switch to enter the menu screens when all of the following conditions are satisfied.

- The menu screen entering screen is selected.
- The “i” information reminder is off.

NOTE

While driving, the setting items available on the combination meter display (color LCD) are limited.

3-40 Instruments and controls/Combination meter display (color LCD)

The menu list is as follows.

1st menu	2nd menu	3rd menu
Screen Settings	Welcome Screen	—
	Good-bye Screen	—
	Gauge Initial Movement	—
	Units	—
	Tire Pressure Units (if equipped)	—
	Languages	—
Warning Volume* (if equipped)	—	—
EyeSight (models with EyeSight system)	Lead Vehicle Acquisition Sound	—
	Lead Vehicle Moving Monitor Function	—
	Cruise Control Acceleration Characteristics*	—
RAB (if equipped)	Sonar Audible Alarm	—

*: You can also set this while driving.

1st menu	2nd menu	3rd menu
Vehicle Setting	Keyless Entry System	Audible Signal (if equipped)
		Hazard Warning Flasher
		Security Relocking (if equipped)
		Driver Door Unlock (if equipped)
		Rear Gate/Trunk Unlock (if equipped)
	Defogger	—
	Interior Light	—
	Auto Light Sensor (if equipped)	—
	Welcome Lighting (if equipped)	Approaching Time Set
One-touch lane changer	—	
Default Settings	—	—

By operating the “▲” or “▼” switch on the steering wheel, you can select the menu. Pull the “**I**/SET” switch to enter the selected menu.

NOTE

If you enter the “Go Back” menu, the system will return to the previous screen.

▼ **Screen Settings**

After entering the “Screen Settings” menu, select one of the following menus.

▽ **Welcome Screen**

The combination meter display (color LCD), multi-function display (color LCD), and audio/navigation unit of welcome screen can be activated or deactivated.

▽ **Good-bye Screen**

The good-bye screen can be activated or deactivated.

▽ **Gauge Initial Movement**

The movement of the meter needles and gauge needles that occurs when the ignition switch is turned to the “ON” position can be activated or deactivated.

▽ **Units**

Changes the units displayed in the combination meter display (color LCD), the

type A multi-function display (black and white) and the type B multi-function display (color LCD).

▽ **Tire Pressure Units (if equipped)**

Changes the units displayed in the Tire Pressure Monitoring system.

▽ **Languages**

Changes the language displayed in the combination meter display (color LCD) and the multi-function display (color LCD).

▼ **Warning Volume (if equipped)**

Sets the EyeSight warning volume, the BSD/RCTA warning volume and the RAB warning volume.

▼ **EyeSight (models with EyeSight system)**

NOTE

For models with the EyeSight system, refer to the Owner’s Manual supplement for the EyeSight system.

After entering the “EyeSight” menu, select one of the following menus.

▽ **Lead Vehicle Acquisition Sound**

When adaptive cruise control is used, the buzzer that sounds if a vehicle is detected in front or if detection is not possible can be activated or deactivated.

▽ **Lead Vehicle Moving Monitor Function**

When adaptive cruise control is used, the buzzer that sounds if a vehicle in front has started can be activated or deactivated.

▽ **Cruise Control Acceleration Characteristics**

Adaptive Cruise Control acceleration characteristics can be set in four steps.

▼ **RAB (models with EyeSight system)**

The Sonar Audible Alarm can be set to on or off.

NOTE

For models with Reverse Automatic Braking system, refer to “Reverse Automatic Braking System” 7-57.

▽ **Sonar Audible Alarm**

When the Reverse Automatic Braking system is in operation, the warning sound to notify that an obstacle is detected in the rear can be activated or deactivated.

▼ Vehicle Setting

After entering the “Vehicle Setting” menu, select one of the following menus.

▼ Keyless Entry System

Sets the settings used when the keyless access function was operated.

- Audible Signal (if equipped)
Sets the electronic chirp that sounds when the door is locked or unlocked.

- Hazard Warning Flasher

Sets the operation of the hazard warning flasher that blinks when the door is locked or unlocked.

- Security Relocking (if equipped)

The automatic locking operation period can be set or customized. Select the preferred seconds to customize the operation period.

- Driver Door Unlock (if equipped)

Select only the driver’s door to unlock or all doors to unlock simultaneously when the driver’s door is unlocked.

- Rear Gate/Trunk Unlock (if equipped)

Select only the rear gate to unlock or all doors to unlock simultaneously when accessing from the cargo area.

▼ Defogger

Sets and customizes the operation of the defogger.

▼ Interior Light

Sets and customizes the interior light off delay timer.

▼ Auto Light Sensor (if equipped)

Sets and customizes the sensitivity of the auto light sensor.

▼ Welcome Lighting (if equipped)

Sets the leaving time and approaching time.

- Approaching time set

Sets the illumination time of the headlights that illuminate when you approach the vehicle.

- Leaving time set

Sets the time until the headlights turn off when you have moved away from the vehicle.

▼ One-touch lane changer

Sets the one-touch lane changer on/off.

▼ Default Settings

Select “Yes” to use the menu screen to restore customized settings to the factory default settings. Select “No” to return to the previous screen without restoring to the factory default settings.

Multi-function display (black and white)**NOTE**

For models with multi-function display (color LCD), refer to “Multi-function display (color LCD)” 3-48.

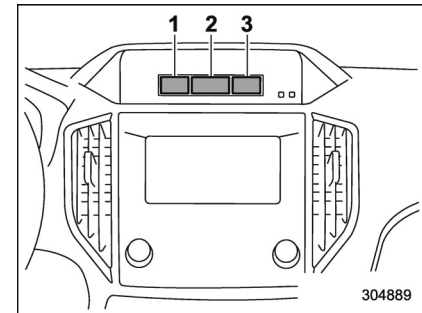

- 1) Outside temperature indicator
- 2) Driving information display
- 3) Clock

With the ignition switch in the “ACC” position, the clock appears on the display.

With the ignition switch in the “ON” position, the outside temperature indicator, driving information display and clock all appear on the display.

NOTE

The indicated values vary in accordance with changes in the vehicle's running conditions. Also, the indicated values may differ slightly from the actual values and should thus be treated only as a guide.

■ Driving information display

NOTE

You can set the units for both the multi-function display (black and white) and the combination meter at the same time. For details about setting the language and units, refer to "Type A combination meter" 3-11 or "Menu screens" 3-39.

▼ How to change the information display

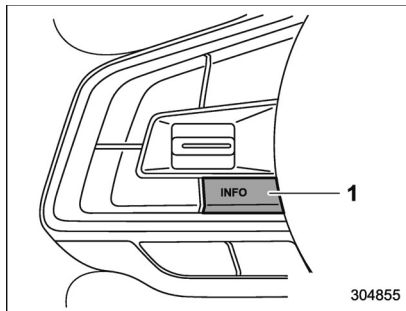

1) INFO button

Pressing the INFO button on the steering wheel switches the display in the following sequence.

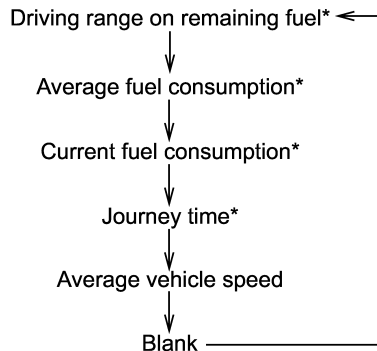

*: models without combination meter display (color LCD)

▼ **Driving range on remaining fuel (models without combination meter display (color LCD))**

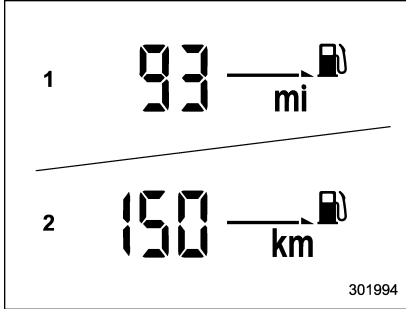

- 1) When setting the displayed unit as MPH
- 2) When setting the displayed unit as km/h

The driving range indicates the distance that can be driven taking into account the amount of fuel remaining in the tank and the average rate of fuel consumption.

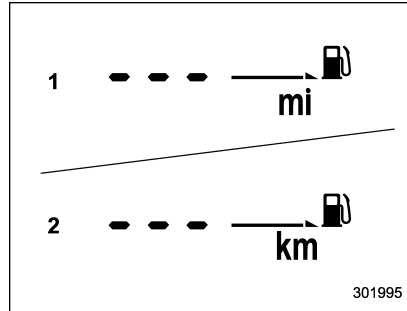

- 1) When setting the displayed unit as MPH
- 2) When setting the displayed unit as km/h

If the driving range is shown as “---”, there is only a tiny amount of fuel left in the tank.

NOTE

The driving range on remaining fuel is only a guide. The indicated value may differ from the actual driving range on remaining fuel, so you must immediately fill the tank when the low fuel warning light illuminates.

▼ **Average fuel consumption (models without combination meter display (color LCD))**

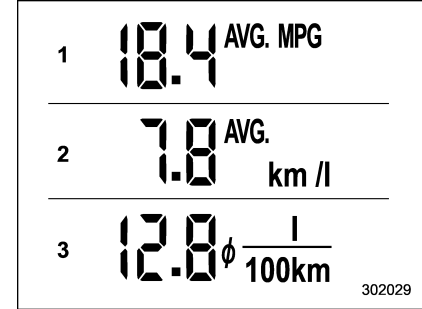

- 1) Displays the driving range per gallon of fuel
- 2) Displays the driving range per liter of fuel
- 3) Displays the fuel consumption per 100 km

This display shows the average rate of fuel consumption since the trip meter was last reset.

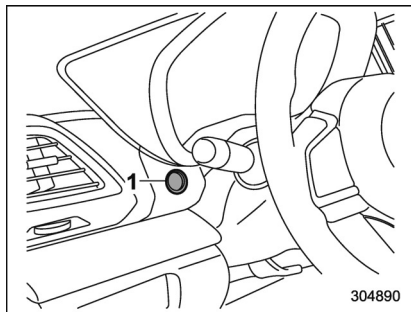

1) TRIP RESET switch

Press the TRIP RESET switch to switch between the displays for the average fuel consumption that corresponds to the A trip meter mileage and the average fuel consumption that corresponds to the B trip meter mileage.

When the trip meter displays is reset, the corresponding average fuel consumption value is also reset.

NOTE

- When the trip meter display is reset, the average fuel consumption corresponding to that trip meter display is not shown until the vehicle has subsequently covered a distance of 1 mile (or 1 km).
- The units for measuring average fuel

consumption cannot be changed.

▼ Current fuel consumption (models without combination meter display (color LCD))

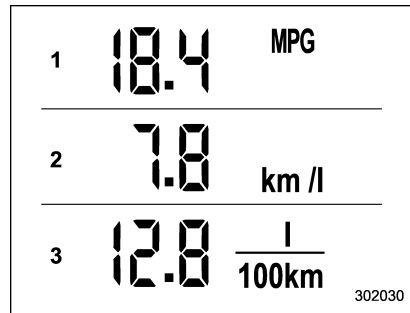

- 1) Displays the driving range per gallon of fuel
- 2) Displays the driving range per liter of fuel
- 3) Displays the fuel consumption per 100 km

This indication shows the rate of fuel consumption at the present moment.

▼ Journey time (models without combination meter display (color LCD))

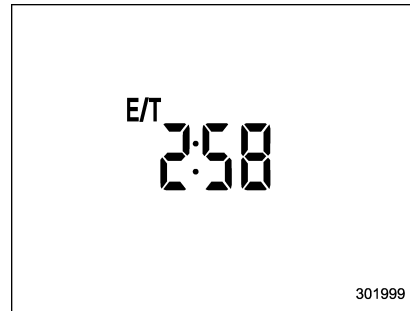

The journey time shows the time that has elapsed since the ignition switch was turned to the "ON" position.



The journey time indication flashes each time a complete hour has elapsed. If the display is giving a reading other than the journey time, the display switches to the journey time, flashes for 5 seconds, and returns to its original reading each time a complete hour has elapsed.

NOTE

The journey time is reset when the ignition switch is turned to the "ACC" or "LOCK"/"OFF" position.

▼ Average vehicle speed

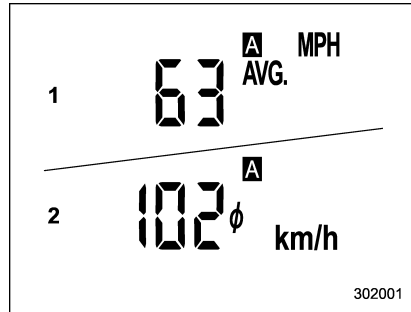

- 1) When units in miles is selected
- 2) When units in km is selected

This display shows the average vehicle speed since the trip meter was last reset. Pressing the TRIP RESET switch toggles

the display between the average vehicle speed corresponding to the A trip meter display and the average vehicle speed corresponding to the B trip meter display. When either of the trip meter displays is reset, the corresponding average vehicle speed value is also reset.

NOTE

When either trip meter display is reset, the average vehicle speed corresponding to that trip meter display is not shown until the vehicle has subsequently covered a distance of 1 mile (or 1 km).

▼ Turn off display of driving information display

Select the blank space in the menu to exit the driving information display selection.

NOTE

- The average fuel consumption and average vehicle speed are calculated even while the driving information display is not displayed.
- Even if you turn off the driving information display, the display will automatically turn on when the battery voltage is disconnected and then reconnected for battery replacement or fuse replacement.

■ Outside temperature indicator

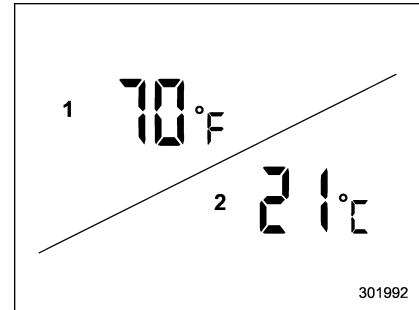

- 1) U.S.-spec. models
- 2) Except U.S.-spec. models

The outside temperature indicator shows.

NOTE

- The outside temperature indicator shows the temperature around the sensor. Therefore, the temperature indication may differ from the actual outside air temperature.
- The temperature unit cannot be changed.

▼ Road surface freeze warning indication

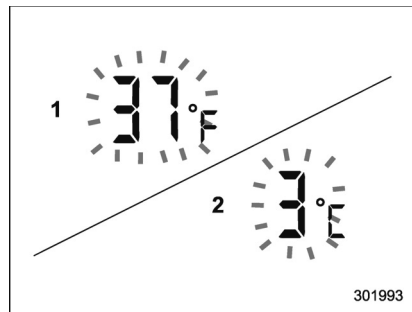

- 1) U.S.-spec. models
- 2) Except U.S.-spec. models

When the outside temperature drops to a certain temperature or lower, the temperature indication flashes for 5 seconds to show that the road surface may be frozen. If the display is already indicating that the outside temperature is low when the ignition switch is turned to the “ON” position, the indication does not flash.

NOTE

The outside temperature indication may differ from the actual outside temperature. The road surface freeze warning indication should be treated only as a guide. Be sure to check the

condition of the road surface before driving.

■ Clock

For details about clock setting, refer to “Clock” 3-63.

Multi-function display (color LCD) (if equipped)

NOTE

For models with multi-function display (black and white), refer to “Multi-function display (black and white)” 3-43.

WARNING

Always pay adequate attention to safe driving when operating the multi-function display (color LCD) while the vehicle is in motion. When operation of the multi-function display (color LCD) is disturbing your awareness and ability to concentrate on driving, stop the vehicle in a safe place before performing operations on the screen. Also, do not concentrate on the display while driving. Doing so may cause you to look away from the road and could result in an accident.

■ Features

The multi-function display (color LCD) has the following functions.

Description	Page
Displays useful messages, such as notification, etc.	3-50
Displays basic screens (e.g. fuel consumption screen, etc.)	3-51
Sets and adjusts maintenance notification	3-62

Also, the multi-function display (color LCD) can also be used to set and initialize the multi-function display (color LCD) itself.

NOTE

- When the vehicle is in motion, certain functions and selections may not be available.
- You can set the language and units for both the multi-function display (color LCD) and the combination meter at the same time. For details about setting the language and units, refer to “Menu screens” 3-39.
- The images displayed in this Owner’s Manual are sample images. The actual image may vary depending on the market and vehicle specifications.

■ Welcome screen

When the driver’s door is opened and closed, the welcome screen will appear for a short time.

NOTE

- The welcome screen will disappear when the ignition switch is turned to the “ON” position while the welcome screen is displayed.
- The welcome screen can be set to on or off. For details, refer to “Screen Settings” 3-42.
- For a certain period of time after the welcome screen has once appeared, it may not appear again even when the driver’s door is opened and closed again. This does not indicate a malfunction.

■ Self-check screen

NOTE

When the setting is “On”, the self check screen appears. For details about this setting, refer to “On/Off setting” 3-62.

When the ignition switch is turned to the “ON” position, the vehicle self-check will be performed. The screens corresponding to the following items will appear one after another for several seconds each.

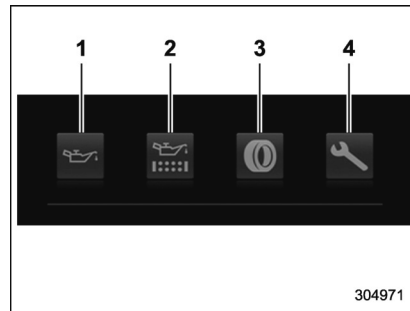

- 1) Engine oil: Checks the interval of engine oil replacement.
- 2) Oil filter: Checks the interval of oil filter replacement.
- 3) Tires: Checks the interval of tire rotation.
- 4) Inspection and maintenance: Checks the interval of inspection and maintenance.

When the checks are performed, the color

– CONTINUED –

of the icon corresponding to the checked item will change.

If there is a notification, the message will be displayed. Take the appropriate actions based on the message indicated.

After the self-check is completed, today's date, the stored birthday or the stored anniversary is displayed.

NOTE

- After performing the maintenance, change the setting of the corresponding maintenance item. For details, refer to "Maintenance settings" 3-62.

- The maintenance notification screen will be displayed under either of the following conditions.

- The period of time remaining until the registered notification date is 15 days or less.

- The total driving distance remaining until the registered notification distance is approximately 311 miles (500 km) or less.

- The maintenance notification screen will be displayed until either of the following conditions is satisfied.

- The period of time passed after the registered notification date is 15 days or more.

- The total distance driven after the registered notification distance is

approximately 311 miles (500 km) or more.

■ Interruption screen

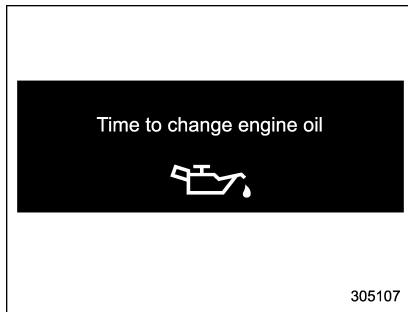

Example

Useful messages, such as reminder information, weather information (if equipped) and traffic information (if equipped) may interrupt the current screen and appear on the display accompanied by a beep. Take proper action according to the message.

The interruption screen will return to the original screen after a few seconds. Also, you can press the INFO button to skip the interruption screen.

■ Basic operation

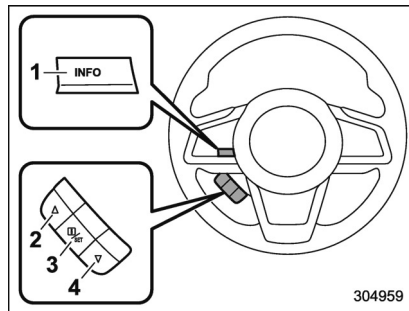

Control switch

1) INFO button

2) ▲

3) ⓘ/SET

4) ▼

Press the INFO button on the steering wheel to switch the item displayed on the basic screen. You can operate the items on the setting screen by using the "▲", "▼" and "ⓘ/SET" switches.

Basic screens

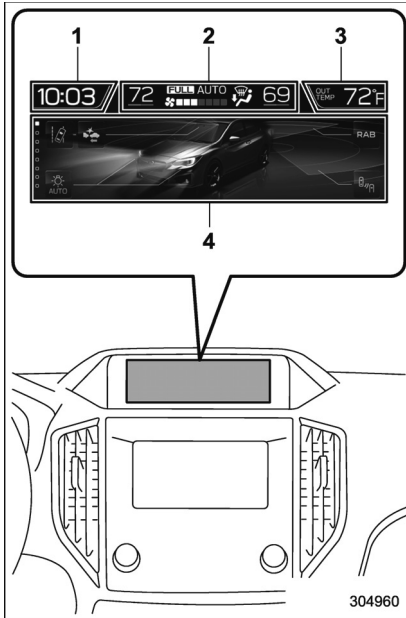

- 1) Clock
- 2) Climate control (if equipped)*
- 3) Outside temperature
- 4) Information screen

*: This is not displayed on the multi-function display (color LCD) when the ignition switch

is in the "ACC" position.

While the ignition switch is in the "ACC" or "ON" position, the basic screen will be displayed.

▼ Outside temperature indicator

The outside temperature is displayed on the multi-function display (color LCD).

NOTE

- The outside temperature indicator shows the temperature around the sensor. Therefore, the temperature indication may differ from the actual outside air temperature.
- The temperature unit cannot be changed.

▼ Climate control screen (if equipped)

The climate control status is displayed on the multi-function display (color LCD).

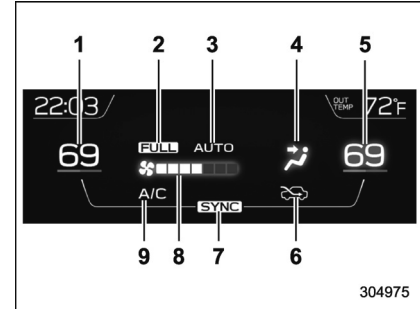

Climate control screen

- 1) Set temperature indicator (left-hand side)
- 2) FULL AUTO indicator
- 3) AUTO indicator
- 4) Airflow mode indicator
- 5) Set temperature indicator (right-hand side)*¹
- 6) Air inlet selection indicator
- 7) SYNC indicator*¹
- 8) Fan speed indicator
- 9) Air conditioner ON indicator

*¹: Models with the SYNC function only

When operating the climate control system, the basic screen switches to the climate control screen. For details about

climate control operation, refer to "Climate control panel" 4-2.

▼ **Clock**

The clock can be displayed in either 12-hour display or 24-hour display. For details about the setting, refer to "Clock" 3-63.

▼ Information screen

Press the INFO button on the steering wheel to switch the item displayed on the information screen.

Content	Description	Page
Electric components operating status screen	Displays the operating status of the electric components and equipment.	3-54
Prevention safety screen	Displays the status of your vehicle.	3-54
EyeSight screen*1	Displays the operating status of EyeSight.	3-55
Favorite screen	Displays up to 3 optional items.	3-55
Weather information screen*2	Displays weather information.	3-56
Traffic information*2/Navigation*3 screen	Displays information linked with the navigation system.	3-56
Audio screen	Displays audio system information.	3-57
Fuel consumption screen	Displays fuel consumption information.	3-57
Clock screen	Displays the clock.	3-57
Guidance screen	Moves to the setting screen.	3-58

*1: Models with EyeSight system

*2: Models with SiriusXM Satellite Radio

*3: Models with navigation system

▽ Electric components operation screen

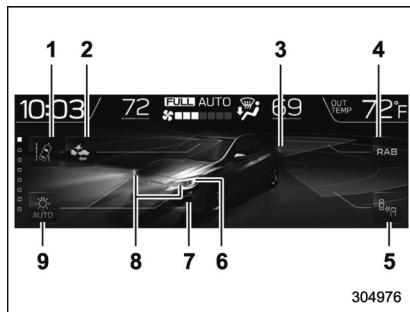

- 1) Lane Departure/Sway Warning indicator*1
- 2) Pre-Collision Braking System indicator*1
- 3) Stop lights
- 4) Reverse Automatic Braking (RAB)*1
- 5) BSD/RCTA*1
- 6) Headlights*2
- 7) Front fog lights*2
- 8) Turn signals
- 9) Auto on/off headlights*1

*1: If equipped

*2: The daytime running lights are not displayed.

This screen displays the electric components operation status of the vehicle.

NOTE

- Indicators do not display for functions that are not equipped to the vehicle.
- The indicators of functions that are not operating are displayed in grey.
- For models with auto on/off headlights; If the multi-function display (color LCD) unit, battery, or fuse is removed, the Auto on/off headlights indicator turns off on the multi-function display (color LCD). After reinstalling the removed multi-function display (color LCD) unit, battery, or fuse to the vehicle, the Auto on/off headlights indicator will appear once more if the light control switch is turned to the "AUTO" position.

▽ Prevention safety screen

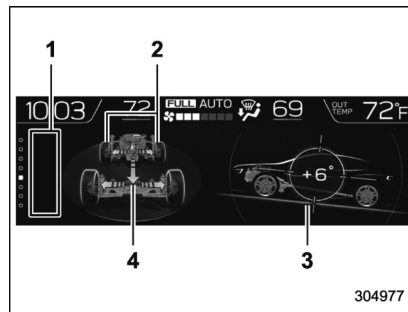

- 1) Telltale screen
- 2) Steering angle
- 3) Vehicle posture
- 4) Running condition

This screen displays the driving status of the vehicle and the operation status functions. For functions that are operating, the indicator will illuminate or flash.

NOTE

The vehicle posture indication may differ from the actual vehicle posture.

▽ EyeSight screen (models with EyeSight system)

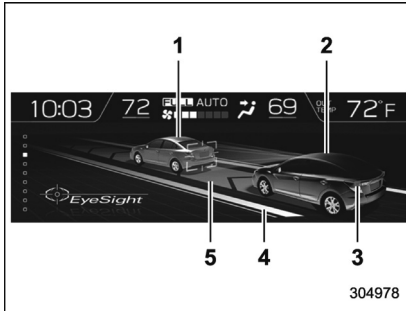

- 1) Lead vehicle indicator
- 2) Your own vehicle indicator
- 3) Stop lights
- 4) Road line indicator
- 5) Lane indicator

This screen displays the status of the EyeSight system. The lead vehicle indicator moves forward and backward depending on the distance with the vehicle in front. For details, refer to the Owner's Manual supplement for the EyeSight system.

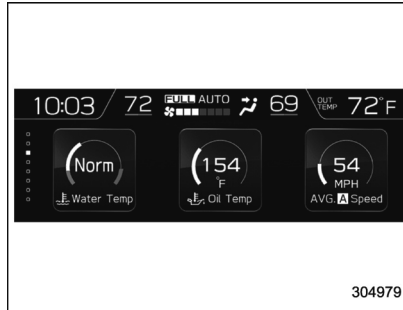

▽ Favorite screen



Favorite screen (display example)

This screen displays up to three optional pieces of information that can be selected from the following items.

Item	Details
	The engine coolant temperature is displayed.
	The engine oil temperature is displayed.
	The average vehicle speed is displayed.
	The accelerator opening ratio is displayed.
	The vehicle posture is displayed.
	The current rate of fuel consumption is displayed.
	The direction of the vehicle is displayed.*1
	The weather information is displayed.*2

Item	Details
	The posted speed limit of the road you are currently driving on is displayed.*1
	The calendar is displayed.
	Nothing is displayed.

*1: If equipped

*2: Models with SiriusXM Satellite Radio

NOTE

Some displayed items may be not displayed depending on the model and specifications.

The items shown in the favorite screen can be changed. For details, refer to "Favorite setting" 3-61.

▽ Weather information screen (if equipped)

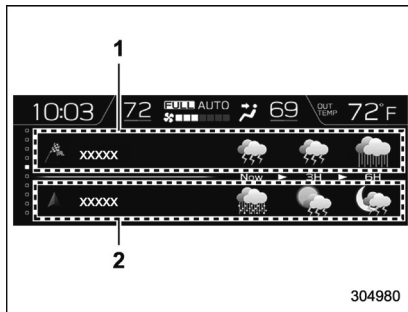

- 1) Weather information for the destination.*
- 2) Weather information for the current location.

*: Only when a destination is set in the navigation system

The weather information is displayed on the screen.

NOTE

- When all of the following conditions are satisfied, weather information is displayed.
 - The vehicle is equipped with an audio and navigation system for SiriusXM satellite radio.
 - You have a current SiriusXM

satellite radio subscription.

- The weather forecast for the set destination remains displayed until a new destination is set or until you reach the destination.
- Depending on the reception timing of XM, the display of weather information may be delayed.

▽ Navigation screen (models with navigation system)

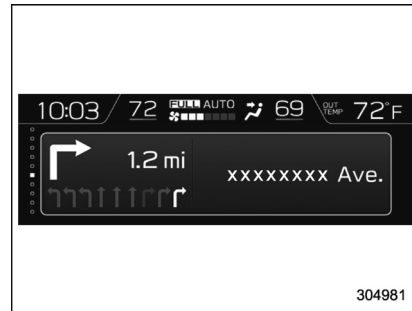

The navigation system information to the destination is displayed on the screen.

NOTE

When a destination is not set in the navigation system, the compass orientation, name, route sign and speed limit of the road the vehicle is traveling on

remain displayed on the screen.

▽ Audio screen



304982

The screen of the currently selected audio source is displayed.

For details about how to use the audio set, refer to the separate navigation/audio Owner's Manual.

▽ Fuel consumption screen

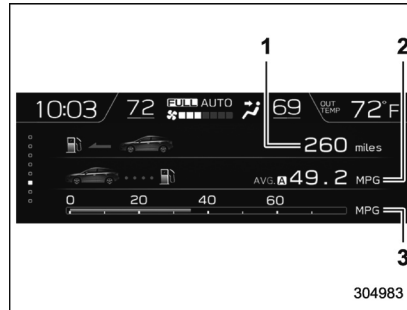

- 1) Driving range on remaining fuel
- 2) Average fuel consumption corresponding to the driving distance of each trip meter
- 3) Current fuel consumption

The fuel consumption information is displayed on the screen.

▽ Clock/date screen



304984

The time and date are displayed.

You can adjust the time and date. For details, refer to "Clock" 3-63.

▽ Guidance screen



When the INFO button on the steering wheel is pressed and held on this screen, the setting screen can be displayed.

For details, refer to "Setting screen" 3-58.

NOTE

When the combination meter display (color LCD) is displaying the menu screen entering screen, the system will not move to the setting screen even if the INFO button is pressed and held.

■ Setting screen

1. Press and hold the INFO button on the guidance screen. The top menu is displayed.
2. Operate the "▲" or "▼" switch to select the preferred menu from the top menu.
3. Pull the "i/SET" switch to enter the selected menu.
4. Operate the "▲" or "▼" switch to select the preferred menu from the 2nd menu.
5. Pull the "i/SET" switch to enter the selected menu.

The menu list is as follows.

Top menu	2nd menu	Description		Page
Time/Date	Time/Date*	Set and adjust the time and date. 12h or 24h format can be selected.		3-60
	Birthday	Set a birthday.		3-60
	Anniversary	Set an anniversary day.		3-60
	Go Back	Return to the 1st menu.		—
Display/Beep	Screen Off*	Turn the screen on or off.	Yes or No	3-60
	Favorite	Set and customize the triple meter.		3-61
	Bypass Screen	Set the bypass screen for each item.	On or Off	3-61
	Beep	Adjust the beep sound volume.	High, Low or Off	3-61
	Go Back	Return to the 1st menu.		—
Maintenance	Engine Oil	Set and adjust the oil maintenance notification date.		3-62
	Oil Filter	Set and adjust the oil filter maintenance notification date.		3-62
	Tires	Set and adjust the tire maintenance notification date.		3-62
	Maintenance Schedule	Set and adjust the vehicle maintenance notification date.		3-62
	ON/OFF	Turn on or off the self-check screen that is activated when the ignition switch is turned to the "ON" position.	On or Off	3-62
	Clear All Settings	Clear all settings for maintenance items.	Yes or No	3-62
	Go Back	Return to the 1st menu.		—
Initialize	—	Reset all settings to the default settings.	Yes or No	3-63
Go Back	—	Return to the setting screen.		—

*: You can also set this while driving.

▼ **Date and time settings**

You can set the date, time and 12h or 24h format settings.

▽ **Current date and time setting**

For details about clock setting, refer to “Clock” 3-63.

▽ **Birthday setting**

If a birthday or anniversary is approaching, a message will be displayed when the ignition switch is turned to the “ON” position. This function can be set to on or off. For details, refer to “Bypass screen setting” 3-61.

1. Select “Birthday” from the 2nd menu in the setting screen. Refer to “Setting screen” 3-58.

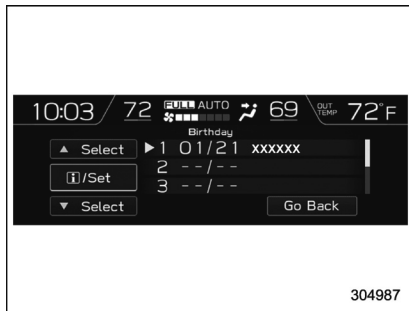

2. Select from the list the number that

you want to register.

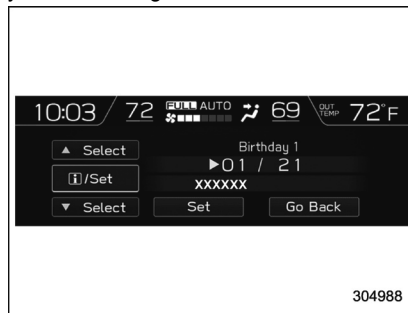

3. Enter the date and the text by using the control switches.

4. Select “Set” to exit settings. Select “Go Back” to return to the previous screen without applying the setting changes.

NOTE

You can store a maximum of 5 birthdays.

▽ **Anniversary setting**

1. The procedure for setting an anniversary is the same as “Birthday setting” 3-60, except that in step 1 “Anniversary” is selected.

NOTE

You can store a maximum of 5 anniversaries.

▼ **Display/Beep settings**

You can set the display settings and volume settings.

▽ **Screen OFF setting**

1. Select “Screen Off” from the 2nd menu in setting screen. Refer to “Setting screen” 3-58.



2. Select “Yes” to turn off the screen. Select “No” to return to the previous screen.

Restoring the screen

When the INFO button is operated after the ignition switch is turned to the “ON” or

“ACC” position, the screen will be restored. The screen will be restored with the basic screen that was displayed when the screen was turned off.

NOTE

While the screen is off, the screen switches to the climate control screen only when the climate control system is operating.

▽ Favorite setting

1. Select the “Favorite” from the 2nd menu in setting screen. Refer to “Setting screen” 3-58.

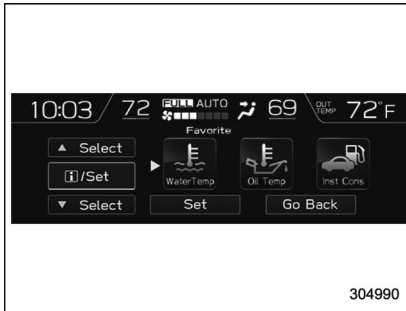

2. Set the desired items by using the control switches. For details about items, refer to “Favorite screen” 3-55.
3. Select “Set” to exit settings. Select “Go

Back” to return to the previous screen without applying the setting changes.

NOTE

- You can display a maximum of the 3 items.
- The same item cannot be selected for the left, center or right location.
- Weather information for 3 hours later or 6 hours later can be displayed.

▽ Bypass screen setting

1. Select “Bypass Screen” from the 2nd menu in the setting screen. Refer to “Setting screen” 3-58.



2. Select “On” or “Off” to turn the display of items on or off by using the control switches.

3. Select “Set” to exit settings. Select “Go Back” to return to the previous screen without applying the setting changes.

NOTE

Traffic information setting is only displayed for the audio unit with SiriusXM satellite radio.

▽ Beep setting

1. Select “Beep” from the 2nd menu in the setting screen. Refer to “Setting screen” 3-58.



2. Set the beep volume by using the control switches.
3. Select “Set” to exit settings. Select “Go Back” to return to the previous screen without applying the setting changes.

▼ Maintenance settings

You can set maintenance reminders.

▽ Engine oil setting

1. Select “Engine Oil” from the 2nd menu in the setting screen. Refer to “Setting screen” 3-58.

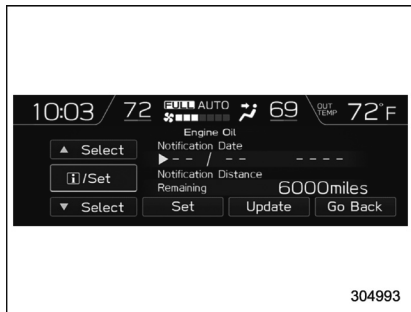

2. Set the date and distance of the reminder by using the control switches.
3. Select “Set” to exit settings. Select “Update” to change the notification distance to the default value. Select “Go Back” to return to the previous screen without applying the setting changes.

NOTE

- The reminder will be displayed by either date or distance in accordance with the setting.
- Even when either “Day” or “Distance” are displayed as “_ _” a pop-up screen will appear.
- The reminder will be displayed until either of the following conditions is satisfied.
 - The period of time passed after the registered notification date is 15 days or more.
 - The total distance driven after the registered notification distance is approximately 311 miles (500 km) or more.

▽ Oil filter setting

The setting procedure is the same as “Engine oil setting” 3-62, but select the “Oil Filter” item in step 1.

▽ Tires setting

The setting procedure is the same as “Engine oil setting” 3-62, but select the “Tires” item in step 1.

▽ Maintenance schedule setting

The setting procedure is the same as “Engine oil setting” 3-62, but select the “Maintenance Schedule” item in step 1.

▽ On/Off setting

1. Select “On/Off” from the 2nd menu on the setting screen. Refer to “Setting screen” 3-58.



2. Select “On” or “Off” to turn the opening screen on or off by using the control switches.
3. Select “Set” to exit settings. Select “Go Back” to return to the previous screen without applying the setting changes.

▽ Clear setting

1. Select “Clear All Settings” from the 2nd menu on the setting screen. Refer to “Setting screen” 3-58.

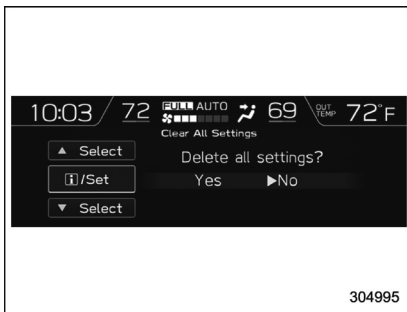

2. Select “Yes” or “No” by using the control switches.

▼ Initialize

You can initialize the items that have been set to your preference.

1. Select “Initialize” from the 2nd menu on the setting screen. Refer to “Setting screen” 3-58.



2. Select “Yes” or “No” by using the control switches.

■ How to get the source code using the open source

Free/Open Source Software Information

This product contains Free/Open Source Software (FOSS).

The license information and/or the source code of such FOSS can be found at the following URL.

<http://www.globaldenso.com/en/open-source/ivi/subaru/>

Clock

For models with a SUBARU genuine navigation and/or audio system, the clock can be adjusted using either “Auto” mode or “Manual” mode.

- Auto mode: automatic clock adjustment
- Manual mode: manual clock adjustment

■ Preparation for clock adjustment setting

Before setting the clock, the setting mode (“Auto” or “Manual”) will need to be selected.

To select the mode, perform the following procedure.

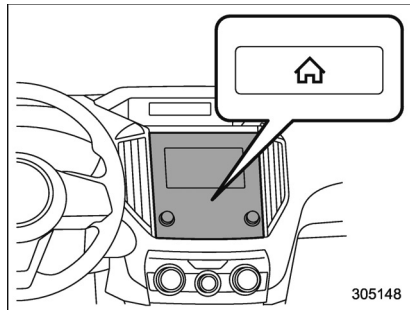

1. Press the  button.
2. Select “Settings”.
3. Select “Vehicle”.
4. Select “Clock adjustment” and then select either “Manual” or “Auto”.

■ Clock setting with automatically

To set the clock automatically, the “Auto” mode must be selected in the clock adjustment setting preparation procedure.

▼ Models with navigation system

The clock will be set automatically where a GPS signal is available.

▼ Models without navigation system

The clock will be set and adjusted automatically when a smartphone is connected via Bluetooth® for transferring phonebook data.

1. Register the smartphone to the audio system. For details, refer to “Bluetooth SETTINGS” in the supplemental Owner’s Manual for the audio/navigation system.
2. Transfer phonebook data to the system. For details, refer to “Bluetooth SETTINGS” in the supplemental Owner’s Manual for the audio/navigation system. The clock will be adjusted automatically.

■ Clock setting with manually

To set the clock in manual mode, “Manual” must be selected in the clock adjustment setting preparation procedure.

▼ Type A multi-function display (black and white)

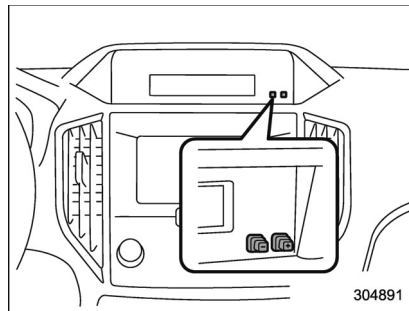

▽ Adjusting the clock

To adjust the clock, press the “+” button or the “-” button beside the clock.

▽ Setting 12-hour or 24-hour display

The clock can be set to 12-hour or 24-hour display. Perform the following procedure to switch the display format.

1. Place the ignition switch in the "LOCK"/"OFF" position.
2. Press and hold the "-" button located near the clock display for approximately 5 seconds. The clock display will then start to flash.
3. While the clock display is flashing, press and hold the "+" button for approximately 2 seconds. The clock format will then change.
4. The clock display will continue to flash for approximately 3 seconds to inform that the clock display has been changed.

▽ Type B multi-function display (color LCD)



▽ Adjusting the clock

1. Select "Time/Date" from the 2nd menu of the setting screen. Refer to "Setting screen" 3-58.
2. Use the control switch to set the date, time and 12-hour or 24-hour format.
3. Select "Set" to exit settings. Select "Go Back" to return to the previous screen without changing the settings.

NOTE

The Birthday/Anniversary and maintenance reminder system function based on the time and date on the multi-function display (color LCD).

■ Regulatory information



The Bluetooth® word mark and logos are registered trademarks owned by Bluetooth SIG, Inc.



Light control switch

■ Precautions and tips

⚠ CAUTION

- Use of any lights for a long period of time while the engine is not running can cause the battery to discharge.
- Before leaving the vehicle, make sure that the lights are turned off. If the vehicle is left unattended for a long time with the lights illuminated, the battery may be discharged.

NOTE

- Even if the key is removed from the ignition switch, the lights can be illuminated by operating the light control switch from the “O” (off) position to the “ ” or “ ” position.
- If the driver's door is opened while the lights are illuminated and the key is removed from the ignition switch, the chirp sound will inform the driver that the lights are illuminated.

■ Headlights

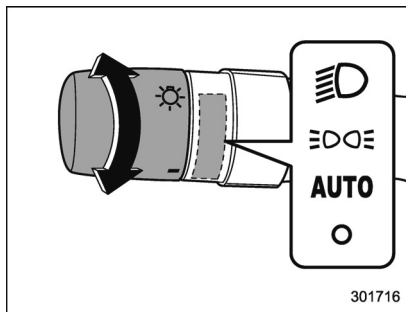

To turn on the headlights, turn the knob on the end of the turn signal lever.

“ ” position

Instrument panel illumination, headlights, parking lights, front side marker lights, rear side marker lights, tail lights and license plate lights are on.

“ ” position

Instrument panel illumination, parking lights, front side marker lights, rear side marker lights, tail lights and license plate lights are on.

“AUTO” position: auto on/off headlights (if equipped)

When the ignition switch is in the “ON” position, the instrument panel illumination, headlights, parking lights, front side marker lights, rear side marker lights, tail lights and license plate lights are automatically on or off depending on the level of the ambient light.

“O” position

The headlights are all off.

NOTE

The sensitivity of the auto on/off headlights can be changed by a SUBARU dealer. Consult your SUBARU dealer for details. Also, for models with a combination meter display (color LCD), the setting can be changed using the display. For details, refer to “Vehicle Setting”  3-43.

▼ Welcome lighting function (if equipped)

The welcome lighting function turns on the low beam headlight for smooth approaching to or exiting from the vehicle at night or in a dark place.

The function is activated while all of the following conditions are met.

- The light control switch is in the

“AUTO” position

- It is dark enough to turn on the auto on/off headlights

When approaching:

While the welcome lighting function is activated, the low beam headlights will automatically illuminate when unlocking the doors and the rear gate (5-door models) by using the remote keyless entry system.

The low beam headlights will remain illuminated for 30 seconds^{*1} and then turn off. However, if any of the following operations is done, the low beam headlights will turn off.

- The doors are locked.
- The light control switch is turned to a position other than “AUTO”.
- The ignition switch is turned to the “ON” position.

When exiting:

While the welcome lighting function is activated, the low beam headlights will remain illuminated even when either of the following operation is done.

- The push-button ignition switch is turned to the “OFF” status (models with “keyless access with push-button start system”)

- The key is pulled out from the ignition switch (models without “keyless access with push-button start system”)

The low beam headlights will turn off under any of the following conditions.

- 3 minutes have passed since the low beam headlights were illuminated by the welcome lighting function.
- 30 seconds have passed since the door is opened and closed.^{*1}
- The light control switch is turned to a position other than “AUTO”.
- The locking procedure is performed twice. When performing the unlocking procedure after performing the locking procedure, perform the locking procedure twice again.

*1: The setting for the period of time in which the low beam headlights remain on by the welcome lighting function can be changed by a SUBARU dealer. Contact your SUBARU dealer for details.

▼ Sensor for the auto on/off headlights (if equipped)

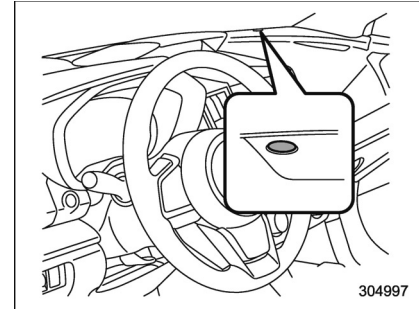

The sensor is on the instrument panel as shown in the illustration.

⚠ CAUTION

If any object is placed on or near the sensor, the sensor may not detect the level of the ambient light correctly and the auto on/off headlights may not operate properly.

■ High/low beam change (dimmer)

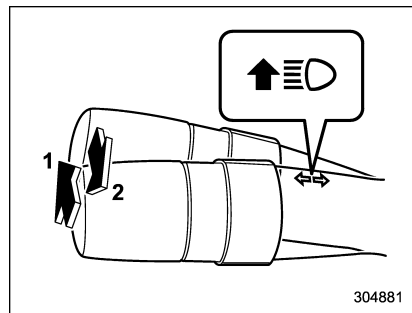

- 1) High beam
- 2) Low beam

When the headlights are on high beam, the high beam indicator light “≡●” on the combination meter is also on.

■ Headlight flasher

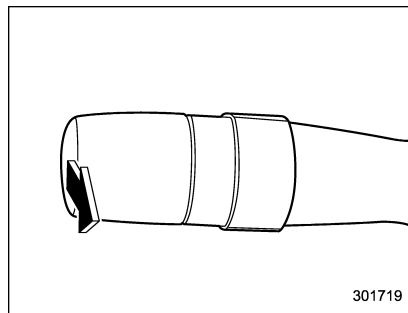

⚠ CAUTION

Do not hold the lever in the flashing position for more than just a few seconds.

To flash the headlights, pull the lever toward you and then release it. The high beam will stay on for as long as you hold the lever.

When the headlights are on high beam, the high beam indicator light “≡●” on the combination meter also illuminates.

■ High beam assist function (if equipped)

NOTE

- The high beam assist function utilizes the stereo camera installed at the position of the front map lights.
- For details on how to handle the stereo camera, refer to the Owner's Manual supplement for the EyeSight system.

The high beam assist function automatically changes the headlight from high beam to low beam (or vice versa).

When all of the following conditions are met, the headlight will change to high beam.

- When the vehicle speed increases to or above 20 mph (32 km/h).
- There is no preceding or oncoming vehicle.
- The forward area of the vehicle is dark.
- The road does not have a sharp curve.

When any of the following conditions is met, the headlight will change to low beam.

- When the vehicle speed decreases to or below 10 mph (16 km/h).
- When the forward area of the vehicle is bright.

- When there is a preceding or oncoming vehicle.
- When the EyeSight system is malfunctioning or is temporarily stopped.

NOTE

The factory setting (default setting) for this function is set as “operational”. This setting can be changed to OFF (non-operation) at SUBARU dealers. For more details, contact a SUBARU dealer.

▼ How to use the high beam assist function

The high beam assist function will be activated when all the following conditions are met.

- The light control switch is in the “AUTO” position and the low beam headlights are on automatically.
- The turn signal lever is pushed forward.

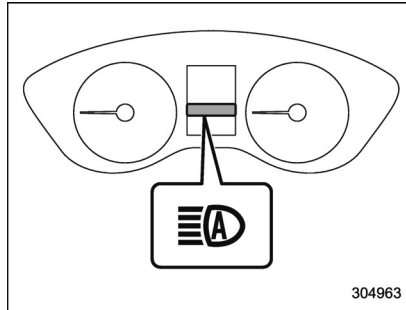

High beam assist indicator

When the high beam assist function is activated, the high beam assist indicator light (green) on the combination meter will illuminate.

NOTE

If the high beam assist function is malfunctioning or is temporarily stopped, the headlight will be fixed at low beam. For details, refer to the Owner's Manual supplement for the EyeSight system.

▼ How to temporarily lower the sensitivity of the high beam assist function

The sensitivity of the high beam assist function can be lowered by performing the following operations.

1. Before turning the ignition switch to the “ON” position, set the light control switch to the “AUTO” position and push the signal lever forward (high beam position).
2. Turn the ignition switch to the “ON” position and within approximately 15 seconds, press the “” (following distance setting) switch more than 10 times consecutively.

When the sensitivity of the high beam assist function is lowered, the high beam assist indicator light “” (yellow) on the combination meter will flash.

NOTE

- The sensitivity of the high beam assist function cannot be lowered in the following conditions.
 - Cruise control or Adaptive Cruise Control is in operation
 - The EyeSight warning indicator (yellow) is illuminated
- The sensitivity of the high beam assist function returns to normal level

the next time the ignition switch is turned to the “LOCK”/“OFF” position and the engine is restarted.

▼ **How to change the headlight mode manually**

Change to the low beam:

When you return the turn signal lever to the center position, the high beam assist function will turn off and the high beam assist indicator light (green) will turn off.

Change to the high beam:

When you turn the light control switch to the “ ” position, the headlight mode will be changed to the high beam.

At this time, the high beam assist function will turn off, the high beam assist indicator (green) will turn off and the high beam indicator light will turn on.

NOTE

- **After manually changing the headlight mode to the high beam, if you turn on the high beam assist function, return the light control switch to the “AUTO” position.**
- **When manually changing the headlight mode to the high beam, if you turn the light control switch to the “ ” position, the instrument panel illumination, parking lights, front side marker lights, rear side marker lights, tail lights**

and license plate lights will be on.

▼ **Tips for the high beam assist system**

- The high beam assist function recognizes the conditions surrounding the vehicle based on the brightness of illumination ahead of your vehicle, etc. Therefore, the headlight mode may switch in some situations that do not match to the driver’s sense.
- A bicycle or cargo cycle may not be detected.
- Under the following situations, the brightness of ambient illumination may not be detected correctly and the high beam assist function may not work properly. As a result, the glare of the high beam may disturb the oncoming vehicle or vehicle ahead. Also, the low beam mode may continue although there are no oncoming vehicles and vehicles ahead. In the such cases, change the headlight mode manually.
 - In bad weather (fog, snow, sand storm, heavy rain, etc.)
 - When the windshield glass is dirty or fogged
 - When the windshield is cracked or damaged
 - When the stereo camera is deformed or the stereo camera lenses

are dirty

- If there are lights similar to the headlights or the tail lights in the surrounding area
- When an oncoming vehicle or vehicle ahead is driven without its headlights and tail lights on
- If the headlights of an oncoming vehicle or the tail lights of a vehicle ahead are dirty or discolored, or if the light beams are not aimed correctly
 - When a rapid change of brightness continues while driving
 - When driving on a road with many ups and downs or uneven surfaces
 - When driving on a road with many curves
 - When there are some objects that reflect light strongly, such as a road sign or a mirror in vehicle ahead
 - When the rear part of the vehicle ahead, such as a container, reflects light strongly
 - When the headlights of your vehicle are damaged or dirty
 - When your vehicle is tilted, such as in case the vehicle has a flat tire or is being towed
 - Immediately after the engine has started
- In the following conditions, the headlight mode will not be automatically chan-

ged from the high beam to the low beam.

- When your vehicle passes an oncoming vehicle suddenly in a blind curve
- When another vehicle passes in front of your vehicle
- When an oncoming vehicle or vehicle ahead comes in and out of view because of continuous curves, median strips, roadside trees, etc.
- If the stereo camera detects the light of the front fog lights of an oncoming vehicle, the headlight mode may change from the high beam to the low beam automatically.
- The headlight mode may change from the high beam to the low beam, or the low beam mode may continue, when affected by a street light, traffic signal, illumination of an advertisement board, or a reflective object such as a road sign and signboard.
- The timing of the change of headlight mode may differ due to the following factors.
 - Color or brightness of the headlights of an oncoming vehicle or the tail lights of a vehicle ahead
 - The headlights of the oncoming vehicle or the tail lights of the vehicle ahead are covered with mud, snow, etc.
 - Movement and direction of an oncoming vehicle or a vehicle ahead

- When the headlights of an oncoming vehicle or the tail lights of a vehicle ahead illuminate on only one side
- When the oncoming vehicle or vehicle ahead is a motorcycle
- Conditions of a road (slope, curve, road surface, etc.)
- Number of passengers and weight of loaded cargo
- Limitation of the detection ability of the stereo camera

■ Daytime running light system

WARNING

When the daytime running lights are illuminated, the tail lights do not illuminate. When it becomes dark outside, turn the light switch to the  position to illuminate the headlights and tail lights. This will improve visibility and allow other drivers to see your vehicle more easily.

The daytime running lights will automatically illuminate when the following conditions are fulfilled.

- The engine is running.
- The parking brake is fully released.
- The light control switch is in the “AUTO” (if equipped), “” or off position.

- For CVT models, the select lever is in a position other than the “P” position.

NOTE

When the light switch is in the “” position, the instrument panel illumination, front side marker lights, tail lights and license plate lights are also illuminated.

Steering Responsive Headlight (SRH) (if equipped)

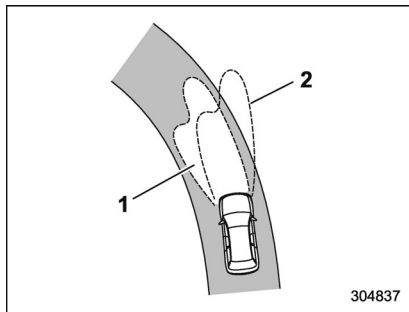

- 1) The target area of illumination when SRH is activated
- 2) The target area of illumination when SRH is not activated

SRH is a function that automatically moves the headlight beam to the left or right in accordance with the steering angle. This function helps to improve the visibility at night by illuminating the road ahead at corners and intersections.

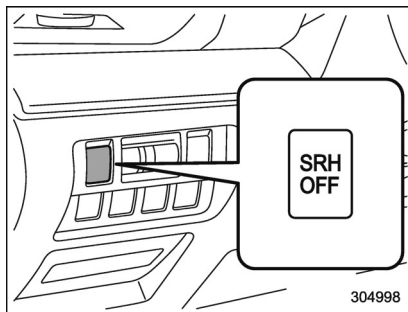

You can turn the SRH function on or off by pressing the SRH OFF switch.

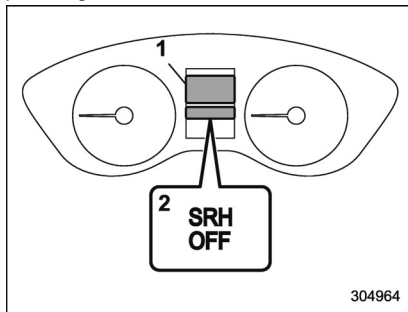

- 1) Warning screen
- 2) SRH OFF indicator

The SRH OFF indicator on the combination meter turns off when SRH is turned

on.

The SRH OFF indicator on the combination meter illuminates when SRH is turned off.

If SRH is malfunctioning, a message appears on the warning screen when the ignition switch is in the "ON" position. It indicates that SRH has been deactivated. Contact a SUBARU dealer for an inspection.

NOTE

- If you turn the ignition switch to the "OFF" position with SRH turned off and then start the engine again, SRH will automatically turn on.
- When you turn the ignition switch to the "ON" position, the SRH OFF indicator will illuminate and turn off after several seconds.
- SRH only activates when the vehicle is traveling forward at the speed of approximately 5 mph (8 km/h) or more.
- SRH may not activate when the shift lever (MT models) is selected in 1st gear.

Headlight beam leveler (models with LED headlights)

The LED headlights produce more light than conventional halogen headlights.

When the vehicle is carrying a heavy load and the headlight beams are angled upwards, the driver of an oncoming vehicle may experience glare.

To prevent this, the automatic headlight beam leveler adjusts the headlights to the optimum height automatically depending on the load the vehicle is carrying.

Fog light switch (if equipped)

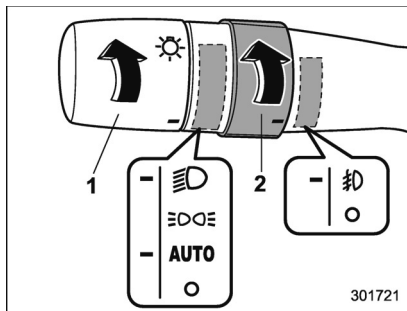

- 1) Headlight switch
- 2) Fog light switch

The front fog lights will turn on when the fog light switch is placed in the “” position while the headlights are in the following condition.

- while the headlight switch is in the “” position
- for models with the auto on/off headlights, while the headlight switch is in the “AUTO” position and the low beam headlights turn on automatically

To turn off the front fog lights, turn the switch back down to the “” position.

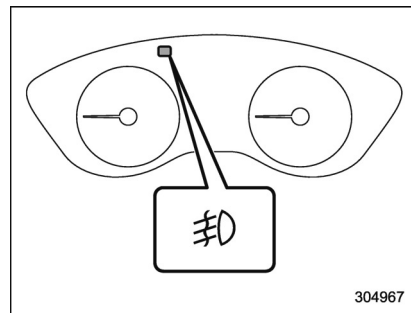

The indicator light on the combination meter will illuminate when the front fog lights are illuminated.

■ Steering responsive fog lights system (if equipped)

The steering responsive fog lights system automatically turns the front fog light on and off based on the steering angle and vehicle speed when entering a curve or driving on curved roads. The system is intended to help prevent accidents by enabling better visibility of curves ahead and early recognition of any disabled vehicles or other obstacles.

The front fog light on the inside of a curve will turn on if all of the following conditions are met.

- The light control switch is in the “

The front fog lights on both sides will turn on as usual if all of the following conditions are met.

- The light control switch is in either of the following conditions.
 - in the “

▼ **Steering responsive fog lights OFF switch**

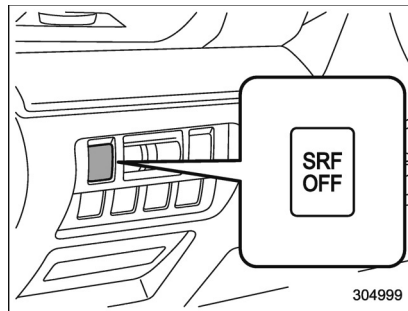

Steering responsive fog lights OFF switch

Press this switch to deactivate the steering responsive fog lights system. Press the switch again to activate the system.

▼ **Steering responsive fog lights OFF indicator**

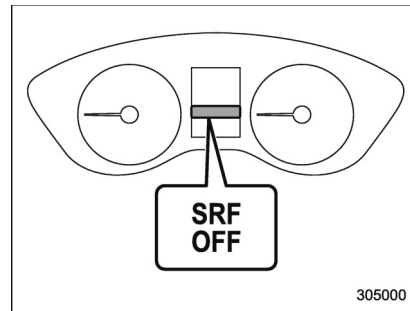

Steering responsive fog lights OFF indicator

This indicator appears when the steering responsive fog lights system is deactivated. This indicator disappears when the system is activated.

Turn signal lever

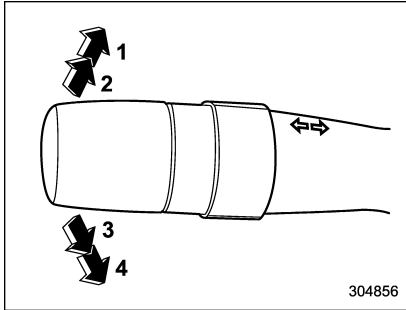

- 1) Right turn
- 2) Lane change right signal
- 3) Lane change left signal
- 4) Left turn

If the lever does not return after cornering, return the lever to the neutral position by hand.

To signal a lane change, push the turn signal lever up or down slightly and hold it during the lane change. The lever will return automatically to the neutral position when you release it.

■ One-touch lane changer

To flash the turn signal and turn signal indicator light three times, push the turn signal lever up or down slightly and immediately release it.

The operational/non-operational setting of the one-touch lane changer's can be changed by a SUBARU dealer. Contact the nearest SUBARU dealer for details.

Wiper and washer

⚠ WARNING

In freezing weather, do not use the windshield washer until the windshield is sufficiently warmed by the defroster.

Otherwise the washer fluid can freeze on the windshield, blocking your view.

⚠ CAUTION

- Do not operate the washer continuously for more than 10 seconds, or when the washer fluid tank is empty. This may cause overheating of the washer motor. Check the washer fluid level frequently, such as at fuel stops.
- Do not operate the wipers when the windshield or rear window is dry. This may scratch the glass, damage the blade rubbers and might cause the wiper motor to fail. Before operating the wiper on a dry windshield or rear window, always use the windshield washer.

- In freezing weather, be sure that the blade rubbers are not frozen to the windshield or rear window before switching on the wipers. Attempting to operate the wiper with the blades frozen to the window glass could cause not only the blade rubbers to be damaged but also might cause the wiper motor to fail. If the blade rubbers are frozen to the window glass, be sure to operate the defroster, windshield wiper deicer (if equipped) or rear window defogger before turning on the wiper.
- If the wipers stop during operation because of ice or some other obstruction on the window, this might cause the wiper motor to fail even if the wiper switch is turned off. If this occurs, promptly stop the vehicle in a safe place, turn the ignition switch to the "LOCK"/"OFF" position and clean the window glass to allow proper wiper operation.
- Use clean water if windshield washer fluid is unavailable. In areas where water freezes in winter, use SUBARU Windshield

Washer Fluid or the equivalent. Refer to "Windshield washer fluid" ¶11-29.

- Do not clean the blade rubbers with gasoline or a solvent, such as paint thinner or benzine. This will cause deterioration of the blade rubbers.

NOTE

- The windshield wiper motor is protected against overloads by a circuit breaker. If the motor operates continuously under an unusually heavy load, the circuit breaker may trip to stop the motor temporarily. If this happens, park your vehicle in a safe place, turn off the wiper switch, and wait for approximately 10 minutes. The circuit breaker will reset itself, and the wipers will again operate normally.
- Clean your blade rubbers and window glass periodically with a washer solution to prevent streaking, and to remove accumulations of road salt or road film. Operate the windshield washer for at least 1 second so that washer solution will be sprinkled all over the windshield or rear window.
- Grease, wax, insects or other material on the windshield or the blade

rubbers results in jerky wiper operation and streaking on the glass. If you cannot remove those streaks after operating the washer or if the wiper operation is jerky, clean the outer surface of the windshield or rear window and the blade rubbers using a sponge or soft cloth with a neutral detergent or mild-abrasive cleaner. After cleaning, rinse the window glass and blade rubbers with clean water. The glass is clean if no beads form on the glass when you rinse with water.

- If you cannot eliminate the streaking even after following this procedure, replace the blade rubbers with new ones. For replacement instructions, refer to "Replacement of wiper blades" ¶11-30.

■ Windshield wiper and washer switches

The wiper operates only when the ignition switch is in the "ON" or "ACC" position.

▼ Operating the wiper lever

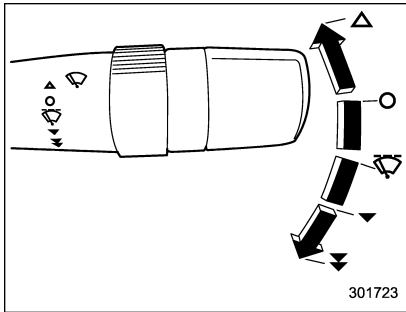

- △ : Mist operation (for a single wipe)
- : Off
- ☐ : Intermittent operation
- ▼ : Low speed operation
- ⚡ : High speed operation

For a single wipe of the wipers, push the lever up. The wipers operate until you release the lever.

▼ Wiper intermittent time control

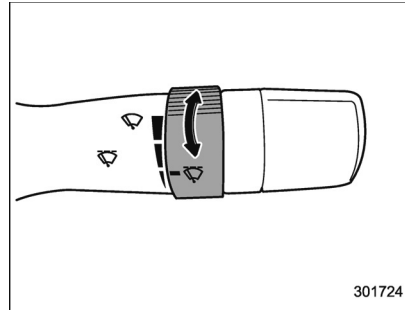

When the wiper switch is in the "☐" position, turn the dial to adjust the operating interval of the wiper. The operating interval can be adjusted in several steps from the shortest interval to the longest.

▼ Windshield washer

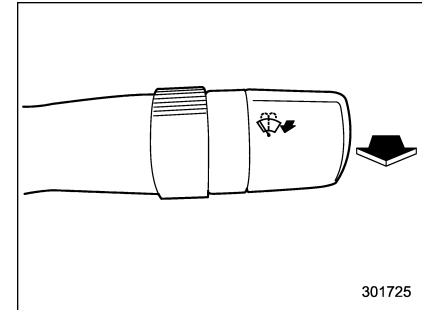

To wash the windshield, pull the wiper control lever toward you. The washer fluid sprays until you release the lever. The wipers operate while you pull the lever.

NOTE

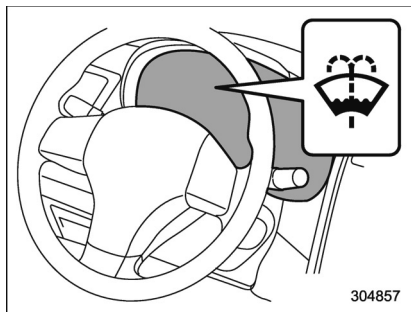

304857



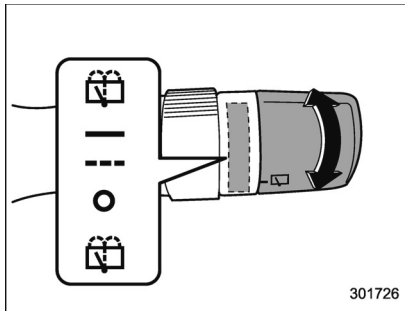

Windshield washer fluid warning light

The windshield washer fluid warning light illuminates when the washer fluid level in the tank has dropped to the lower limit. If the warning light illuminates, refill the tank with fluid. For the refilling procedure, refer to “Windshield washer fluid” 11-29.

■ Rear window wiper and washer switch (5-door models)



301726

-  : Washer operation (accompanied by wiper operation)
-  : Continuous operation
-  : Intermittent operation
-  : Off
-  : Washer operation (accompanied by wiper operation)

▼ Rear wiper

With the switch turned to the “---” position, the rear wiper will operate intermittently at intervals corresponding to the vehicle speed. In this position, when you move the select lever to the “R” position

(CVT models) or the shift lever to the reverse position (MT models), the rear wiper will switch to continuous operation. When you move the select lever/shift lever from the “R” (reverse) position to another position, the rear wiper will return to intermittent operation.

Reverse gear interlocked rear wiper:

Even if the rear wiper switch is in the off “○” position, if the front windshield wiper is operating continuously, the rear wiper will operate intermittently when you move the select lever/shift lever to the “R” (reverse) position.

The factory setting (default setting) of the reverse gear interlocked rear wiper is as follows.

- U.S.-spec. models: Non-operational
- Other models: Operational

This setting can be changed by a SUBARU dealer. Consult your SUBARU dealer for details.



CAUTION

Do not attach anything that disturbs the rear wiper operation on the rear gate. Doing so may damage the rear wiper when it operates.

▼ Washer

To wash the rear window, turn the knob to the "☔" position. The washer fluid sprays and the wiper operates until you release the knob.

Mirrors

Always check that the inside and outside mirrors are properly adjusted before you start driving.

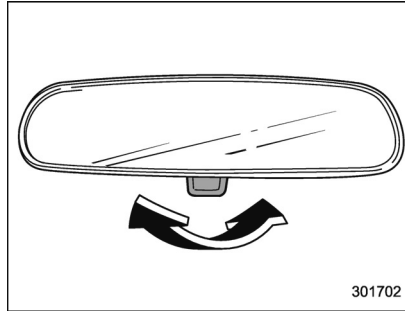
■ Inside mirror

The inside mirror has a day and night position. Pull the tab at the bottom of the mirror toward you for the night position. Push it away for the day position. The night position reduces glare from headlights.

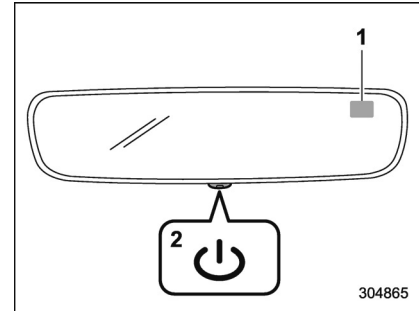
■ Auto-dimming mirror/compass (if equipped)

- 1) Display
- 2) Switch

Congratulations! Your new automobile is equipped with an automatic dimming mirror manufactured by Gentex Corporation. During nighttime driving, the auto-dimming feature senses distracting glare from vehicle headlights behind you and automatically dims to eliminate the glare and preserve your vision.

▼ **To Operate the Auto-Dimming Feature**

Press the “⏻” switch to turn the auto-dimming feature on/off. The auto-dimming feature is enabled when the switch’s green LED indicator is on. The auto-dimming feature will default to on with each ignition cycle.

▼ **To Operate the Compass Feature**

1. To turn the compass feature on/off, press and hold the “⏻” switch for more than 3 seconds or until the display turns on/off. The compass feature will default to on with each ignition cycle.
2. If the display reads “C”, slowly drive the vehicle in circles until compass is calibrated.

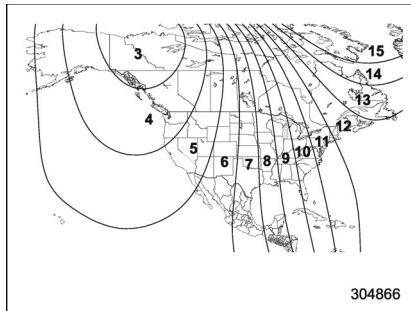

Compass calibration zones

3. To adjust for compass zone variance:
 - (1) Find your current location and zone number on the map.
 - (2) Press and hold the “⏻” switch for more than 6 seconds or until a zone number appears in the display.
 - (3) Once the zone number appears in the display, toggle the “⏻” switch again until your current location zone number appears. After you stop pressing the switch, your new zone number will be saved. Within a few seconds, the display will show a compass direction.
4. If the vehicle’s magnetics have changed or if the compass appears inaccurate, recalibrate the compass. Press and hold the “⏻” switch for more than 9 seconds or until a “C” appears in the display. Once a “C” appears in the display, slowly drive the vehicle in circles until compass is calibrated.

■ **Auto-dimming mirror/compass with HomeLink® (if equipped)**

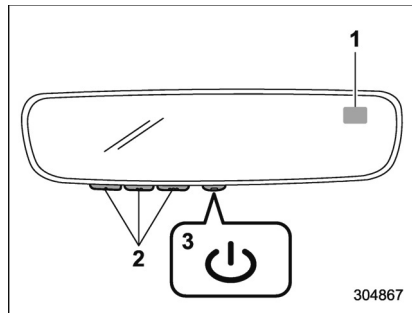

- 1) Display
- 2) HomeLink Buttons
- 3) Switch

Your new automobile is equipped with an automatic dimming mirror manufactured by Gentex Corporation. During nighttime driving, the auto-dimming feature senses distracting glare from vehicle headlights behind you and automatically dims to eliminate the glare and preserve your vision.

▼ To Operate the Auto-Dimming Feature

Press the “☺” switch to turn the auto-dimming feature on/off. The auto-dimming feature is enabled when the switch’s green LED indicator is on. The auto-dimming feature will default to on with each ignition cycle.

▼ To Operate the Compass Feature

1. To turn the compass feature on/off, press and hold the “☺” switch for more than 3 seconds or until the display turns on/off. The compass feature will default to on with each ignition cycle.
2. If the display reads “C”, slowly drive the vehicle in circles until compass is calibrated.

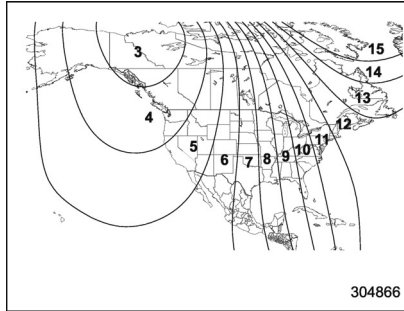

Compass calibration zones

3. To adjust for compass zone variance:
 - (1) Find your current location and zone number on the map.
 - (2) Press and hold the “☺” switch for more than 6 seconds or until a zone number appears in the display.
 - (3) Once the zone number appears in the display, toggle the “☺” switch again until your current location zone number appears. After you stop pressing the switch, your new zone number will be saved. Within a few seconds, the display will show a compass direction.
4. If the vehicle’s magnetics have changed or if the compass appears inaccurate, recalibrate the compass. Press and hold the “☺” switch for more than 9 seconds or

until a “C” appears in the display. Once a “C” appears in the display, slowly drive the vehicle in circles until compass is calibrated.

▼ HomeLink® Wireless Control System

The HomeLink® Wireless Control System provides a convenient way to replace up to three hand-held radio-frequency remotes used to activate devices such as gate operators, garage door openers, entry door locks, security systems, even home lighting. The below steps are generic programming instructions; for Genie and Sommer garage door openers please go directly to the HomeLink website. Additional information and programming videos can be found at www.HomeLink.com and www.youtube.com/HomeLinkGentex.

CAUTION

- Before programming HomeLink to a garage door opener or gate operator, make sure that people and objects are out of the way of the device to prevent potential harm or damage.
- When programming a garage door opener, it is advised to park

outside of the garage.

- Do not use HomeLink with any garage door opener that lacks safety stop and reverse features as required by U.S. federal safety standards (this includes any garage door opener model manufactured before April 1, 1982). A garage door that cannot detect an object signaling the door to stop and reverse does not meet current U.S. federal safety standards.
- It is also recommended that a new battery be placed in the hand-held remote (garage door opener remote) of the device for quicker and more accurate training.
- Some vehicles may require the ignition switch to be turned to the "ON" or "ACC" position for programming and/or operation of HomeLink.
- Keep the hand-held remote (garage door opener remote) of the device you are programming for use in other vehicles as well as for future HomeLink programming. It is also suggested that upon the sale of the vehicle, the

programmed HomeLink buttons be erased for security purposes. Refer to "Erasing HomeLink Buttons" ¶3-85.

▽ Programming a New HomeLink Button

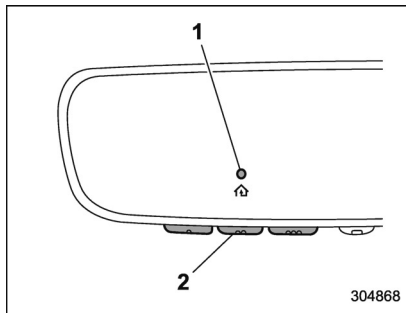

- 1) Indicator Light
- 2) HomeLink Buttons

1. Press and release the HomeLink button that you would like to program. The HomeLink indicator light will flash orange slowly (if not, refer to "Erasing HomeLink Buttons" ¶3-85).

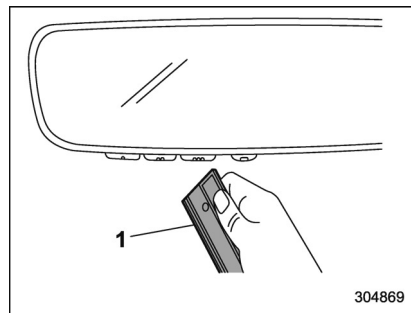

- 1) Garage door opener remote

2. Position the hand-held remote (garage door opener remote) 1 to 3 inches (2 to 8 cm) away from the HomeLink button that you would like to program.

NOTE

Some hand-held remotes (garage door opener remotes) may actually train better at a distance of 6 to 12 inches (15 to 20 cm). Keep this in mind if you have difficulty with the programming process.

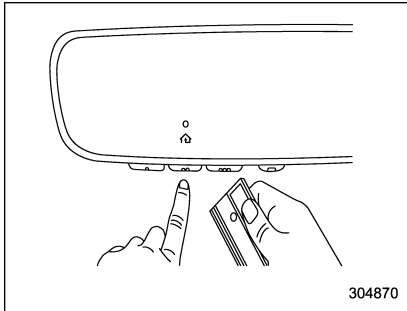

3. While the HomeLink indicator light is flashing orange, press and hold the hand-held remote button. Continue pressing the hand-held remote button until the HomeLink indicator light changes from orange to green. You may now release the hand-held remote button.

NOTE

Some devices may require you to replace this “Programming a New HomeLink Button” step 3 with procedures noted in the “Gate Operator / Canadian Programming” section. Refer to “Gate Operator / Canadian Programming” 3-84.

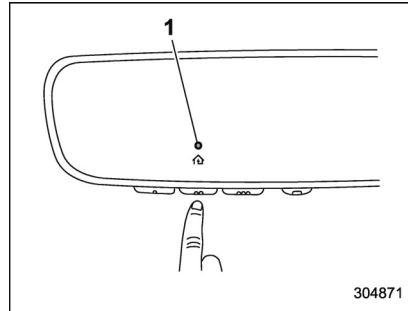

1) Indicator Light

4. Press the HomeLink button that you would like to program and observe the indicator light.

- If the indicator light remains constant green, your device should operate when the HomeLink button is pressed. At this point, if your device operates, programming is complete.
- If the indicator light rapidly flashes green, firmly press, hold for two seconds and release the HomeLink button up to three times to complete the programming process. At this point if your device operates, programming is complete. If the device does not operate, continue with the next step of the programming instructions.

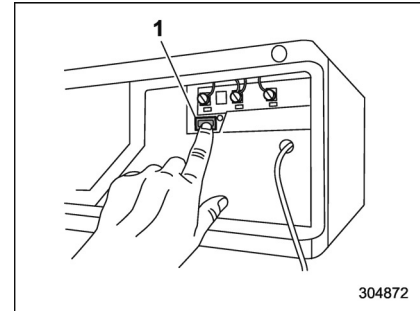

1) “Learn” button

5. At the garage door opener motor, (security gate motor, etc...) locate the “Learn”, “Smart”, or “Program” button. This can usually be found where the hanging antenna wire is attached to the motor-head unit (see the device’s manual to identify this button). The name and color of the button may vary by manufacturer.

NOTE

A ladder and/or second person may simplify the following steps.

6. Firmly press and release the “Learn”, “Smart”, or “Program” button. You now have 30 seconds in which to complete step 7.

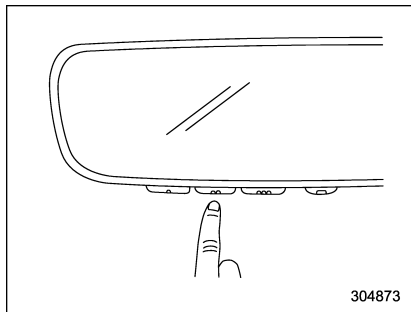

7. Return to the vehicle and firmly press, hold for two seconds and release the HomeLink button up to three times. At this point programming is complete and your device should operate when the HomeLink button is pressed and released.

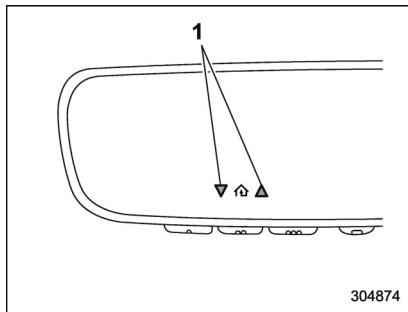

1) Status Indicators

8. If status indicator arrows appear next to the indicator light, please refer to “Garage Door Two-Way Communication” 3-85.

In the event that there are still programming difficulties or questions, additional HomeLink information and programming videos can be found at www.HomeLink.com and www.youtube.com/HomeLinkGentex. For Genie and Sommer garage door openers please go directly to the HomeLink website.

▽ Gate Operator / Canadian Programming

Canadian radio-frequency laws require transmitter remote signals to “time-out” (or quit) after several seconds of transmission, which may not be long enough for HomeLink to pick up the signal during programming. Similar to this Canadian law, some U.S. gate operators are designed to “time-out” in the same manner. The indicator LED on the hand-held remote will go off when the device times out, indicating that it has finished transmitting.

If you live in Canada or you are having difficulties programming a gate operator or garage door opener by using the programming procedures, replace “Programming a New HomeLink Button” step 3 with the following:

While the HomeLink indicator light is flashing orange, press and release (“cycle”) your device’s hand-held remote every two seconds until the HomeLink indicator light changes from orange to green. You may now release the hand-held remote button.

NOTE

If programming a garage door opener or gate operator, it is advised to unplug the device during the “cycling” process to prevent possible overheating.

Proceed with “Programming a New HomeLink Button” step 4 to complete.

▽ Using HomeLink

To operate, simply press and release the programmed HomeLink button. Activation will now occur for the trained device (i.e. garage door opener, gate operator, security system, entry door lock, home/office lighting, etc.). For convenience, the hand-held remote of the device may also be used at any time.

▽ Erasing HomeLink Buttons

To erase programming from the three buttons (individual buttons cannot be erased but can be “reprogrammed” as outlined below), follow the step noted:

Press and hold the two outer HomeLink buttons for at least 10 seconds. The LED indicator will change from continuously lit to rapidly flashing. Release both buttons. Do not hold for longer than 20 seconds. HomeLink is now ready to be programmed at any time beginning with “Programming a New HomeLink Button” - step 1.

▽ Reprogramming a Single HomeLink Button

To program a previously trained button, follow these steps:

1. Press and hold the desired HomeLink button. DO NOT release the button.
2. The indicator light will begin to slowly flash orange after 20 seconds. The HomeLink button can be released at this point. Proceed with “Programming a New HomeLink Button” - step 3.
3. If you do not complete the programming of a new device to the button, it will revert to the previously stored programming.

▽ Garage Door Two-Way Communication

HomeLink has the capability of communicating with your garage door opener. HomeLink can receive and display “closing” or “opening” status messages from compatible garage door opener systems. At any time, HomeLink can also recall and display the last recorded status communicated by the garage door opener to indicate your garage door being “closed” or “opened”.

HomeLink has the capability of receiving this communication from the garage door opener at a range up to 820 feet (250 m).

Range may be reduced by obstacles such as houses or trees. You may have to slow your vehicle speed to successfully receive the garage door opener communication.

▽ Programming Two-Way Communication

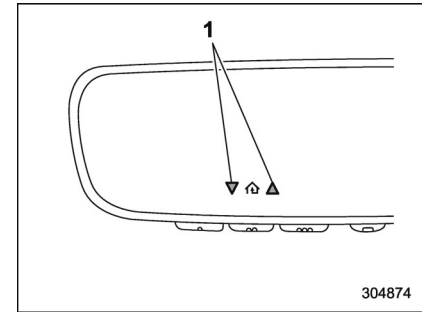

1) Status Indicators

Within five seconds after programming a new HomeLink button, both of HomeLink’s garage door status indicators will flash rapidly green indicating that the garage door two-way communication has been enabled. If your garage door status indicators flashed, two-way communication programming is complete.

If the garage door status indicators do not flash, additional HomeLink information and programming videos can be found

online at www.HomeLink.com and www.youtube.com/HomeLinkGentex.

▽ Using Two-Way Communication

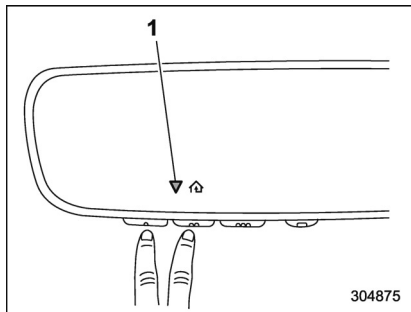

1) Status Indicators

Recall and display (at any time) the last recorded garage door status message communicated to HomeLink by simultaneously pressing HomeLink buttons 1 and 2 for two seconds. HomeLink will display the last recorded status for three seconds.

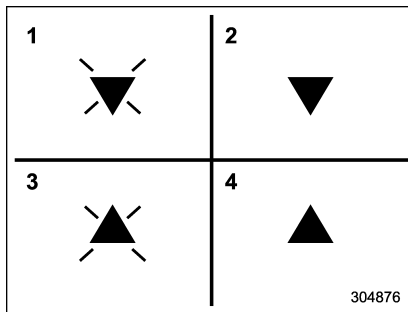

- 1) Garage Door Opener CLOSING (Blinking Orange)
- 2) Garage Door Opener CLOSED (Solid Green)
- 3) Garage Door Opener OPENING (Blinking Orange)
- 4) Garage Door Opener OPENED (Solid Green)

If two-way communication programming is successful, HomeLink will display the status of your garage door opener with arrow indicators.

▽ Certification

In the event that there are still programming difficulties or questions, additional HomeLink information and programming videos can be found at www.HomeLink.com, www.youtube.com/HomeLinkGentex, or by calling the toll-free HomeLink-hotline at 1-800-355-3515.

- U.S.-spec. models

FCC ID: NZLAECHL5



FCC WARNING

Changes or modifications not expressly approved by the party responsible for compliance could void the user's authority to operate the equipment.

This device complies with part 15 of the FCC Rules. Operation is subject to the following two conditions: (1) This device may not cause harmful interference, and (2) this device must accept any interference received, including interference that may cause undesired operation.

- Canada-spec. models

NOTE

This device complies with Industry Canada's licence-exempt RSSs. Operation is subject to the following two conditions: (1) This device may not cause interference; and (2) This device must accept any interference, including interference that may cause undesired operation of the device.

REMARQUE

Le présent appareil est conforme aux CNR d'Industrie Canada applicables aux appareils radio exempts de licence. L'exploitation est autorisée aux deux conditions suivantes: (1) l'appareil ne doit pas produire de brouillage; (2) l'utilisateur de l'appareil doit accepter tout brouillage radioélectrique subi, même si le brouillage est susceptible d'en compromettre le fonctionnement.

HomeLink® and the HomeLink® house are registered trademarks of Gentex Corporation.

WARNING

- When programming the HomeLink® Wireless Control System, you may be operating a garage door opener or other device. Make sure that people and objects are out of the way of the garage door or other device to prevent potential harm or damage.
- Do not use the HomeLink® Wireless Control System with a garage door opener that lacks the safety stop and reverse feature as required by applicable safety standards. A garage door opener which cannot detect an object, signaling the door to stop and reverse, does not meet these safety standards. Using a garage door opener without these features increases risk of serious injury or death. For more information, consult the HomeLink® website at www.homelink.com or call 1-800-355-3515.

■ Outside mirrors

- ▼ Convex mirror (passenger side)

WARNING

Objects look smaller in a convex mirror and farther away than when viewed in a flat mirror. Do not use the convex mirror to judge the distance of vehicles behind you when changing lanes. Use the inside mirror (or glance backwards) to determine the actual size and distance of objects that you view in convex mirror.

▼ Remote control mirror switch

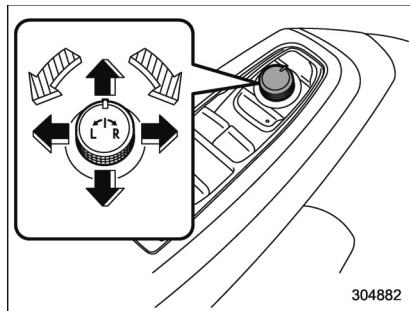

↔: Select side to adjust

➡: Direction control

The remote control mirrors operate only when the ignition switch is in the "ON" or "ACC" position.

1. Turn the control switch to the side that you want to adjust. "L" is for the left mirror, "R" is for the right mirror.
2. Move the control switch in the direction you want to move the mirror.
3. Return the control switch to the neutral position to prevent unintentional operation.

The mirrors can also be adjusted manually.

Defogger and deicer (if equipped)

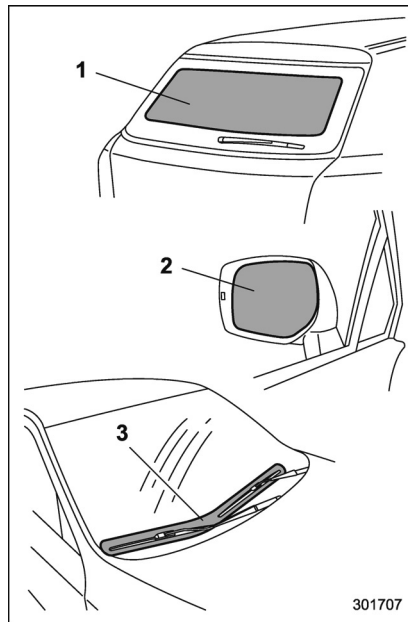

- 1) Rear window defogger
- 2) Outside mirror defogger (if equipped)
- 3) Windshield wiper deicer (if equipped)

The vehicle is equipped with the defogger and the deicer (if equipped) system. The defogger and deicer system is activated only when the ignition switch is in the "ON" position.

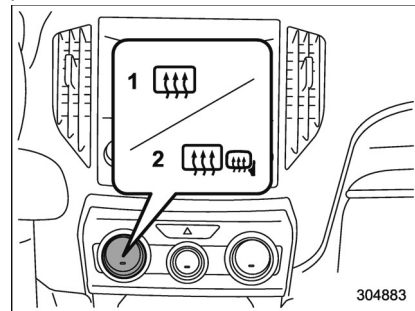

Climate control system type A

- 1) Models without outside mirror defogger
- 2) Models with outside mirror defogger

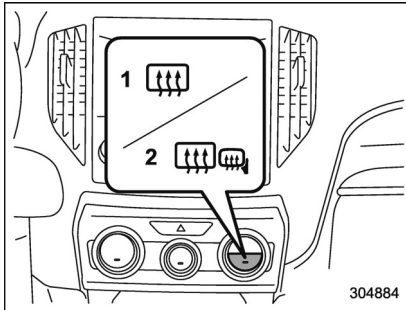

Climate control system type B and C

- 1) Models without outside mirror defogger
- 2) Models with outside mirror defogger

To activate simultaneously the rear window defogger, outside mirror defogger (if equipped) and windshield wiper deicer (if equipped), press the control switch that is located on the climate control panel. The indicator light on the control switch illuminates while the defogger and deicer system is activated.

To turn them off, press the control switch again. They also turn off when the ignition switch is turned to the "ACC" or "LOCK"/"OFF" position.

The defogger and deicer system will automatically shut off after approximately 15 minutes. If the rear window and the

outside mirrors have been cleared and the windshield blade rubbers have been deiced completely before that time, press the control switch to turn them off.

For climate control system (type B and C), it is possible for the defogger and deicer system to be set to continuous operation mode by a SUBARU dealer. Consult your SUBARU dealer for details.

CAUTION

- To prevent the battery from being discharged, do not operate the defogger and deicer system continuously for any longer than necessary.
- Do not use sharp instruments or window cleaner containing abrasives to clean the inner surface of the rear window. They may damage the conductors printed on the window.

NOTE

- Turn on the defogger and deicer system if the wipers are frozen to the windshield.
- If the windshield is covered with snow, remove the snow so that the windshield wiper deicer works effectively.
- While the defogger and deicer system is in the continuous operation mode:
 - If the vehicle speed remains at 9 mph (15 km/h) or lower for 15 minutes, the windshield wiper deicer system automatically stops operating. However, the rear window defogger system and outside mirror defogger system maintain continuous operation in this condition.
 - If the vehicle battery voltage drops below the permissible level, continuous operation of the defogger system and deicer system is canceled and the system stops operating.

Tilt/telescopic steering wheel

⚠ WARNING

- Do not adjust the steering wheel tilt/telescopic position while driving. This may cause loss of vehicle control and result in personal injury.
- If the lever cannot be raised to the fixed position, adjust the steering wheel again. It is dangerous to drive without locking the steering wheel. This may cause loss of vehicle control and result in personal injury.

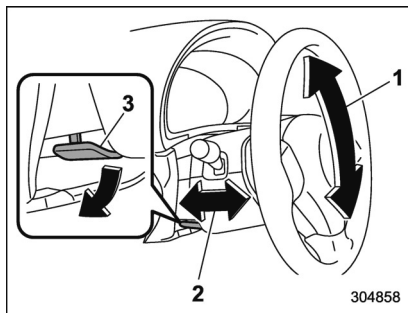

- 1) Tilt adjustment
- 2) Telescopic adjustment
- 3) Tilt/telescopic lock lever

1. Adjust the seat position. Refer to "Front seats" 1-5.
2. Pull the tilt/telescopic lock lever down.
3. Move the steering wheel to the desired level.
4. Pull the lever up to lock the steering wheel in place.
5. Make sure that the steering wheel is securely locked by moving it up and down, and forward and backward.

■ Heated Steering Wheel system (if equipped)

The Heated Steering Wheel system is a function that warms the surface temperature of the steering wheel at a constant temperature.

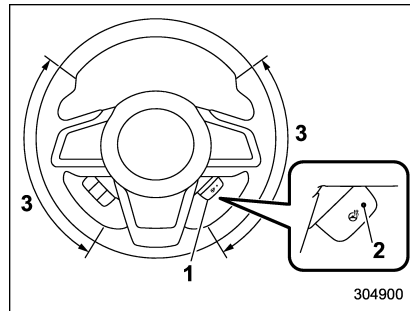

- 1) Heated Steering Wheel switch
- 2) Indicator light
- 3) Heated area

Pull the Heated Steering Wheel switch to warm the steering wheel when the ignition switch is in the "ON" or "ACC" position. Then, the indicator light on the switch will illuminate.

Pull the switch again to turn the Heated Steering Wheel system off manually. The indicator light will turn off.

CAUTION

- If you use the Heated Steering Wheel system without the engine running, the battery voltage may drop below the permissible level and it may not be possible to start the engine.
- There is a possibility that people with delicate skin may suffer slight burns even at low temperatures if they use the Heated Steering Wheel for a long period of time. When using the Heated Steering Wheel, always be sure to warn the persons concerned.
- Do not cover the Heated Steering Wheel with an object such as a steering wheel cover. Doing so may cause the Heated Steering Wheel to overheat.

NOTE

- If the surface temperature of the steering wheel is approximately above 104°F (40°C) when the switch is turned on, the system will not heat the steering wheel. Then, the indicator light will continue to illuminate.
- The Heated Steering Wheel system is equipped with a 30-minute timer. The system will automatically turn off approximately 30 minutes after the switch has been turned on.

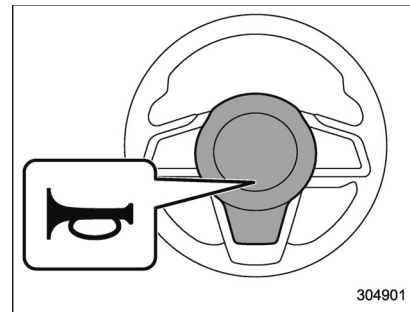
Horn

To sound the horn, push the horn pad.

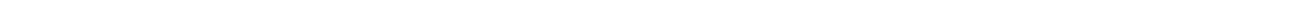
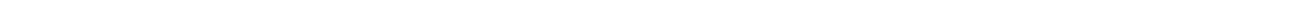
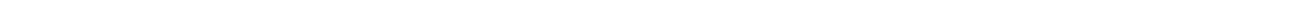
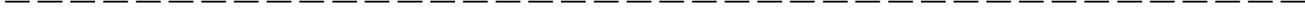
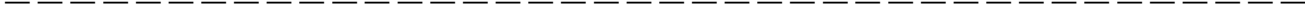
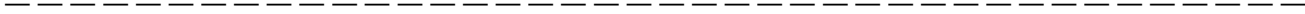
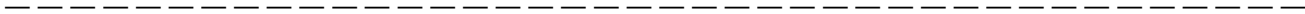
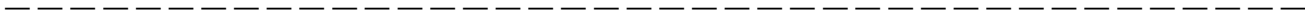
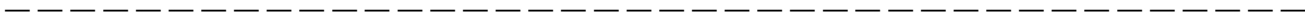

Ventilator control	4-2	Defrosting	4-10
Center ventilators.....	4-2	Operating tips for heater and air conditioner	4-10
Side ventilators.....	4-2	Cleaning ventilation grille.....	4-10
Climate control panel	4-2	Efficient cooling after parking in direct sunlight.....	4-10
Type A.....	4-3	Lubrication oil circulation in the refrigerant circuit.....	4-11
Type B.....	4-4	Checking air conditioning system before summer season.....	4-11
Type C.....	4-5	Cooling and dehumidifying in high humidity and low temperature weather conditions.....	4-11
Automatic climate control operation (type B and C)	4-6	Air conditioner compressor shut-off when engine is heavily loaded.....	4-11
Sensors.....	4-6	Refrigerant for your climate control system.....	4-11
Manual climate control operation	4-7	Air filtration system	4-11
Airflow mode selection.....	4-7	Replacing a cabin air filter.....	4-12
MAX A/C mode (for type B and C).....	4-8		
Temperature control.....	4-8		
Fan speed control.....	4-9		
Air conditioner control.....	4-9		
Air inlet selection.....	4-9		
To turn off the climate control system.....	4-9		

Ventilator control

■ Center ventilators

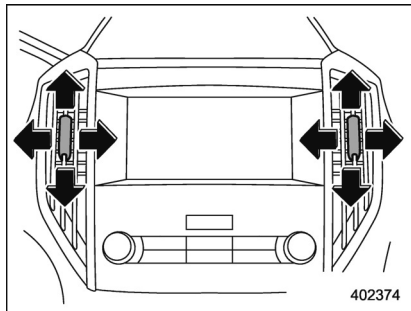

Center ventilators

To adjust the airflow direction, move the tab. To close the ventilator, move the tab all the way down.

■ Side ventilators

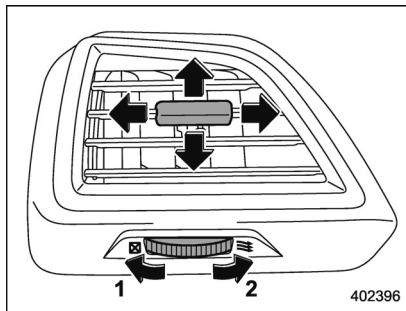

Side ventilators

- 1) Close
- 2) Open

To adjust the flow direction, move the tab.

Climate control panel

⚠ WARNING

- The cooling function operates only when the engine is running.
- Do not leave children or adults who would normally require the support of others alone in your vehicle. Pets should not be left alone either. On hot, sunny days, temperatures in a closed vehicle could quickly become high enough to cause severe or possibly fatal injuries to people or animals.

■ Type A

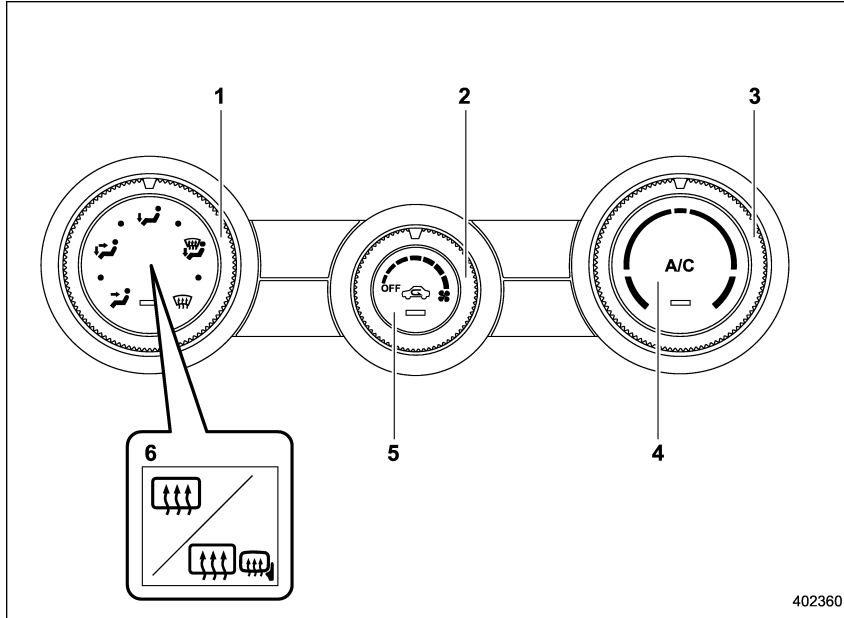

- 1) Airflow mode selection dial (Refer to "Airflow mode selection" ¶4-7.)
- 2) Fan speed control dial (Refer to "Fan speed control" ¶4-9.)
- 3) Temperature control dial (Refer to "Temperature control" ¶4-8.)
- 4) Air conditioner button (Refer to "Air conditioner control" ¶4-9.)
- 5) Air inlet selection button (Refer to "Air inlet selection" ¶4-9.)
- 6) Rear window defogger button and mirror heater button (if equipped) (Refer to "Defogger and deicer" ¶3-88.)

■ Type B

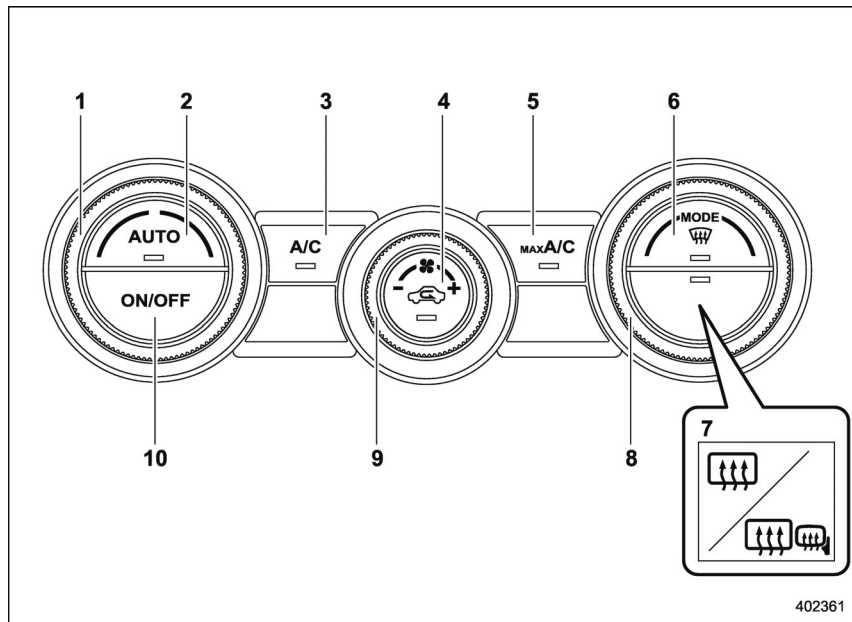

- 1) Temperature control dial (Refer to “Automatic climate control operation (type B and C)” 4-4-6 and/or “Temperature control” 4-8.)
- 2) AUTO button (Refer to “Automatic climate control operation (type B and C)” 4-6.)
- 3) Air conditioner button (Refer to “Air conditioner control” 4-9.)
- 4) Air inlet selection button (Refer to “Air inlet selection” 4-9.)
- 5) MAX A/C button (Refer to “MAX A/C mode (for type B and C)” 4-8.)
- 6) Defroster button (Refer to “Defrosting” 4-10.)
- 7) Rear window defogger button and mirror heater button (if equipped) (Refer to “Defogger and deicer” 3-88.)
- 8) Airflow mode selection dial (Refer to “Airflow mode selection” 4-7.)
- 9) Fan speed control dial (Refer to “Fan speed control” 4-9.)
- 10) ON/OFF button (Refer to “Automatic climate control operation (type B and C)” 4-6.)

NOTE

The climate control screen is displayed on the multi-function display (color LCD). Refer to “Climate control screen” 3-51.

■ Type C

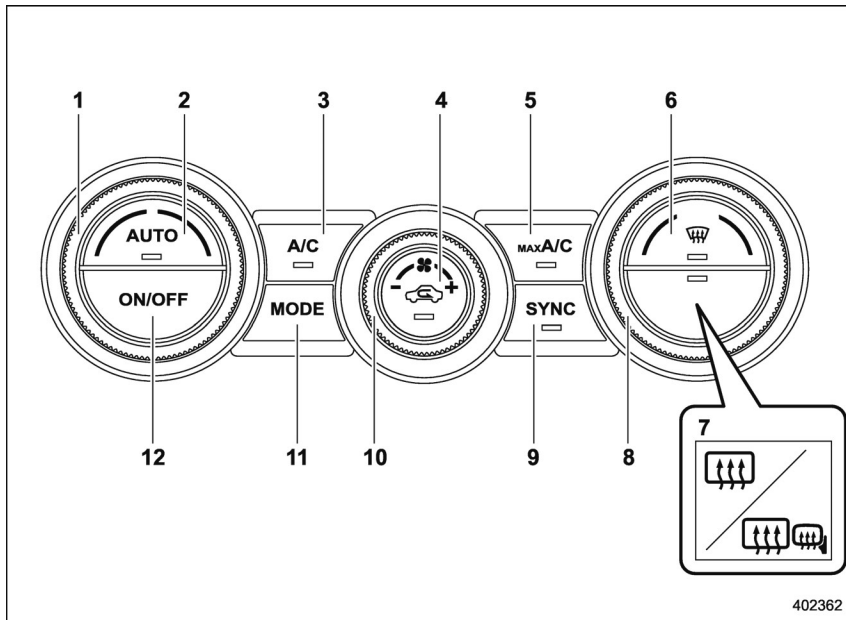

- 1) Driver's side temperature control dial (Refer to "Automatic climate control operation (type B and C)" 4-6 and/or "Temperature control" 4-8.)
- 2) AUTO button (Refer to "Automatic climate control operation (type B and C)" 4-6.)
- 3) Air conditioner button (Refer to "Air conditioner control" 4-9.)
- 4) Air inlet selection button (Refer to "Air inlet selection" 4-9.)
- 5) MAX A/C button (Refer to "MAX A/C mode (for type B and C)" 4-8.)
- 6) Defroster button (Refer to "Defrosting" 4-10.)
- 7) Rear window defogger button and mirror heater button (if equipped) (Refer to "Defogger and deicer" 3-88.)
- 8) Passenger's side temperature control dial (Refer to "Temperature control" 4-8.)
- 9) SYNC button (Refer to "SYNC mode (type C)" 4-8.)
- 10) Fan speed control dial (Refer to "Fan speed control" 4-9.)
- 11) Airflow mode selection button (Refer to "Airflow mode selection" 4-7.)
- 12) ON/OFF button (Refer to "Automatic climate control operation (type B and C)" 4-6.)

NOTE

The climate control screen is displayed on the multi-function display (color LCD). Refer to "Climate control screen" 3-51.

Automatic climate control operation (type B and C)

When this mode is selected, the fan speed, airflow distribution, air-inlet control, and air conditioner compressor operation are automatically controlled. To activate this mode, perform the following.

1. Press the AUTO button. The indicator light “FULL AUTO” on the multi-function display (color LCD) illuminates.
2. Set the preferred temperature using the temperature control dial.

NOTE

- Operate the automatic climate control system when the engine is running.
- Even when cooling is not necessary, the air conditioner compressor will automatically turn on if the temperature is set much lower than the current outlet air temperature. Even in this case, the “A/C” indicator light on the control panel illuminates.
- The controllable temperature range may vary depending on the regional specifications of the vehicle.
- If you operate any of the buttons on the control panel other than the ON/OFF button, rear window defogger button, SYNC button and temperature control dial(s) during FULL AUTO

mode operation, the “FULL” indicator light on the multi-function display (color LCD) will turn off and the “AUTO” indicator light will remain illuminated. You can then manually control the system as desired using the button you operated. To change the system back to the FULL AUTO mode, press the AUTO button.

To turn off the climate control system, press the ON/OFF button. Then the air inlet selection will be set to the following.

- When the air inlet selection is set to auto mode: Outside air circulation
- When the air inlet selection is set to manual mode: No change

■ Sensors

The sensors are located as follows.

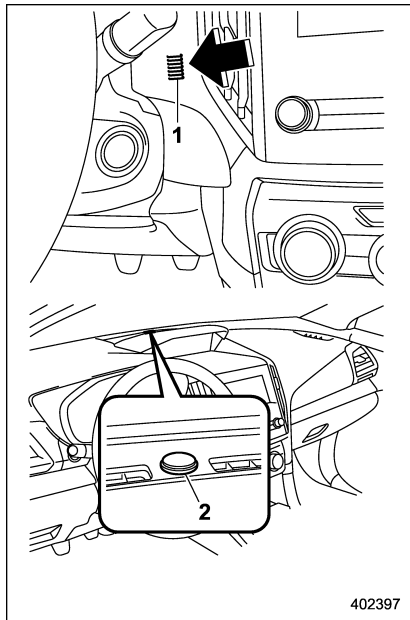

- 1) Interior air temperature sensor
- 2) Solar sensor

The automatic climate control system employs several sensors. These sensors

are delicate. If they are not treated properly and become damaged, the system may not be able to control the interior temperature correctly. To avoid damaging the sensors, observe the following precautions.

- Do not subject the sensors to impact.
- Keep water away from the sensors.
- Do not cover the sensors.

Manual climate control operation

■ Airflow mode selection

Select the airflow mode by using the airflow mode selection dial (type A and B) or the airflow mode selection button (type C).

Airflow modes are as follows.

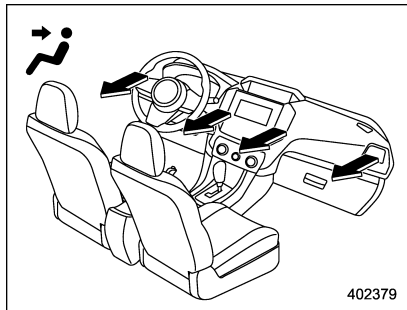

(Ventilation): Instrument panel outlets

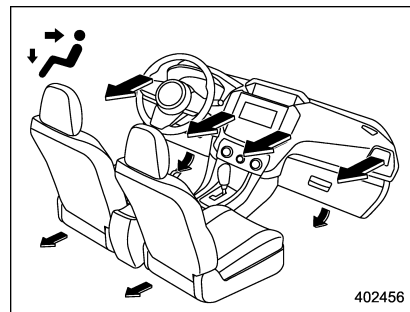

(Ventilation 2 for type B and C): Instrument panel outlets and foot outlets

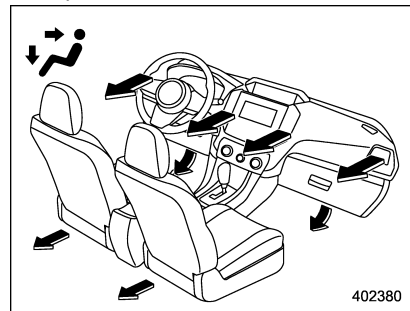

(Bi-level): Instrument panel outlets and foot outlets

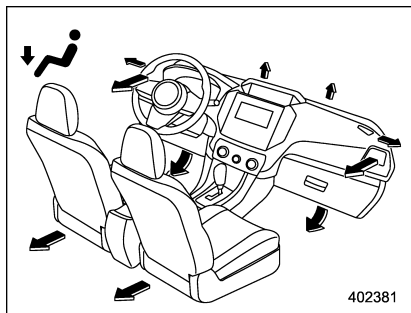

(Heat): Foot outlets, both side outlets of the instrument panel and some through windshield defroster outlets (A small amount of air flows to the windshield and both side windows to prevent fogging.)

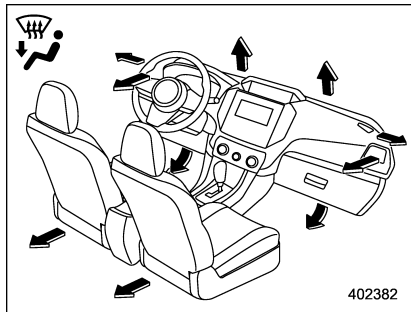

(Heat-def): Windshield defroster outlets,

foot outlets and both side outlets of the instrument panel (Refer to “Defrosting” ¶ 4-10.)

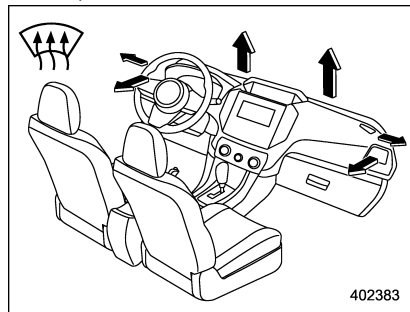

(Defrost): Windshield defroster outlets and both side outlets of the instrument panel (Refer to “Defrosting” ¶ 4-10.)

■ MAX A/C mode (for type B and C)

For quicker cooling, press the MAX A/C button.

When the MAX A/C mode is on, the following settings will be changed automatically.

- The air conditioner will turn on.
- The temperature will be set on the lowest.
- The fan speed will be set on the

maximum speed.

- The air inlet will be set to recirculation.
- The air flow mode setting will be set to ventilation mode.

To turn off MAX A/C mode and return the previous setting, press the MAX A/C button again.

■ Temperature control

Turn the temperature control dial to set the preferred interior temperature.

NOTE

The controllable temperature range may vary depending on the regional specifications of the vehicle.

▼ SYNC mode (type C)

When the SYNC mode is turned on, both the driver’s and passenger’s side temperatures are synchronized using the driver’s side temperature control dial.

Press the SYNC button to turn on the SYNC mode. The SYNC button indicator will illuminate.

Press the SYNC button again or turn the passenger’s side temperature control dial to cancel the SYNC mode. The SYNC button indicator will not illuminate. In this case, temperature control on the driver’s side and passenger’s side is separate.

The temperature will be controlled individually using the driver's and passenger's temperature control dials.

■ Fan speed control

Select the preferred fan speed by turning the fan speed control dial.

■ Air conditioner control

The air conditioner operates only when the engine is running.

Press the air conditioner button while the fan is in operation to turn on the air conditioner. When the air conditioner is on, the "A/C" indicator light illuminates.

To turn off the air conditioner, press the button again.

NOTE

For efficient defogging or dehumidifying in cold weather, turn on the air conditioner. If the ambient temperature decreases to approximately 32°F (0°C), the air conditioner and dehumidification system may not operate properly.

■ Air inlet selection

Select the air inlet by pressing the air inlet selection button.

- Recirculation:

When the indicator light on the air inlet selection button illuminates, interior air is recirculated inside the vehicle. Press the air inlet selection button to the ON position for fast cooling with the air conditioner or when driving on a dusty road.

- Outside air circulation:

When the indicator light on the air inlet selection button does not illuminate, outside air is drawn into the passenger compartment. Press the air inlet selection button to the OFF position when the interior has cooled to a comfortable temperature and the road is no longer dusty.



WARNING

Continued operation in the ON position may fog up the windows. Switch to the OFF position as soon as the outside conditions are no longer dusty.



■ To turn off the climate control system

To turn off the climate control system:

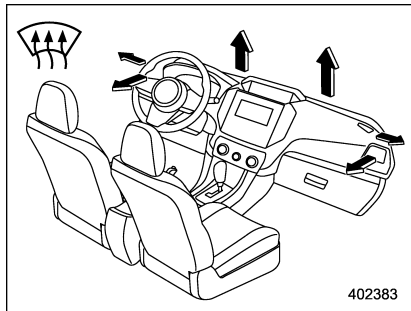

- Type A: select the "OFF" position using the fan speed control dial.
- Type B and C: press the ON/OFF button.

Defrosting



Select the “” or “” mode to defrost or dehumidify the windshield and front door windows.

NOTE

- When the “” or “” mode is selected, the air conditioner compressor operates automatically regardless of the position of the air conditioner button to defrost the windshield more quickly. However the indicator on the air conditioner button will not illuminate. At the same time, the air inlet selection is automatically set to the outside air mode.

For type A climate control system, in this state:

- You cannot stop the air conditioner compressor by pressing the air conditioner button.
- You cannot select the recirculation mode by pressing the air inlet selection button.
- For types B and C climate control system, after defrosting the windshield by pressing the defroster button “”, pressing the button again returns the system to the setting that had been selected before the defroster was activated.

Operating tips for heater and air conditioner

■ Cleaning ventilation grille

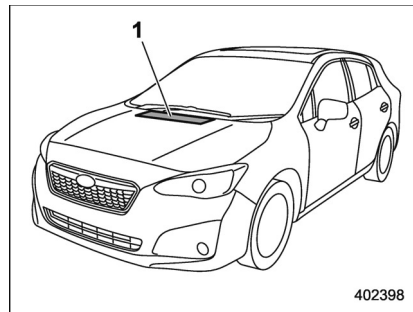

- 1) Front ventilation inlet grille

Always keep the front ventilation inlet grille free of snow, leaves, or other obstructions to ensure efficient heating and defrosting. Since the condenser is located in front of the radiator, this area should be kept clean because cooling performance is impaired by any accumulation of insects and leaves on the condenser.

■ Efficient cooling after parking in direct sunlight

After parking in direct sunlight, drive with the windows open for a few minutes to

allow outside air to circulate into the heated interior. This results in quicker cooling by the air conditioner. Keep the windows closed during the operation of the air conditioner for maximum cooling efficiency.

■ Lubrication oil circulation in the refrigerant circuit

Operate the air conditioner compressor at a low engine speed (at idle or low driving speeds) a few minutes each month during the off-season to circulate its oil.

■ Checking air conditioning system before summer season

Check the air conditioner unit for refrigerant leaks, hose conditions, and proper operation each spring. Have the air conditioning system checked by your SUBARU dealer.

■ Cooling and dehumidifying in high humidity and low temperature weather conditions

Under certain weather conditions (high relative humidity, low temperatures, etc.) a small amount of water vapor emission from the air outlets may be noticed. This condition is normal and does not indicate

any problem with the air conditioning system.

■ Air conditioner compressor shut-off when engine is heavily loaded

To improve acceleration and gas mileage, the air conditioner compressor is designed to temporarily shut off during air conditioner operation whenever the accelerator is fully depressed such as during rapid acceleration or when driving on a steep upgrade.

■ Refrigerant for your climate control system

Your air conditioner uses ozone friendly refrigerant HFC134a. Therefore, the method of adding, changing or checking the refrigerant is different from the method for CFC12 (freon). Consult your SUBARU dealer for service. Repairs needed as a result of using the wrong refrigerant are not covered under warranty.

Air filtration system

Your vehicle's air conditioning system is equipped with an air filtration system. Replace the cabin air filter according to the replacement schedule found in the "Warranty and Maintenance Booklet". This schedule should be followed to maintain the filter's dust collection ability. Under extremely dusty conditions, the filter should be replaced more frequently. Have your filter checked or replaced by your SUBARU dealer. For replacement, use only a genuine SUBARU air filter kit.



CAUTION

Contact your SUBARU dealer if the following occurs, even if it is not yet time to change the filter:

- Reduction of the airflow through the vents.
- Windshield gets easily fogged or misted.

NOTE

The filter can influence the air conditioning, heating and defroster performance if not properly maintained.

■ Replacing a cabin air filter

1. Remove the glove box.

NOTE

We recommend that you take measures to protect the center console with masking tape first, so that you avoid scratching the center console with the glove box.

- (1) Open the glove box.

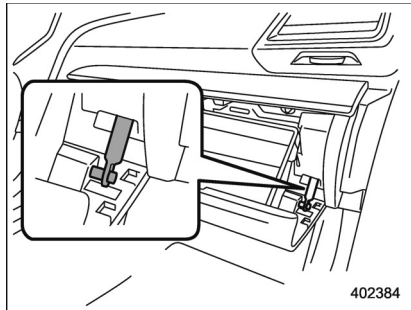

- (2) Remove the damper shaft from the glove box.

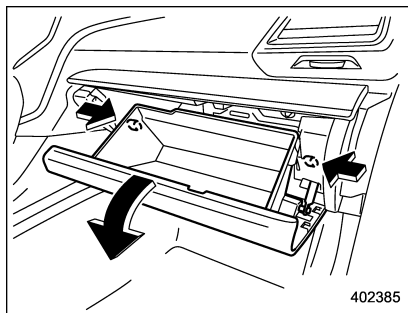

- (3) Push in the stoppers located on both sides of the glove box and then pull down the glove box as far as it will go.

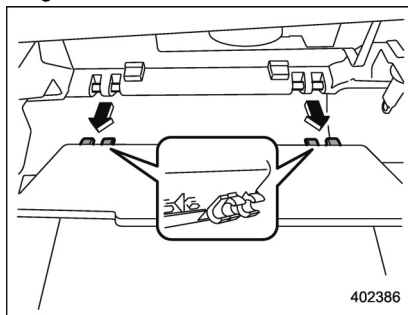

- (4) Pull out the glove box horizontally and remove the hinge portion. When

doing this, be careful not to damage the hinge.

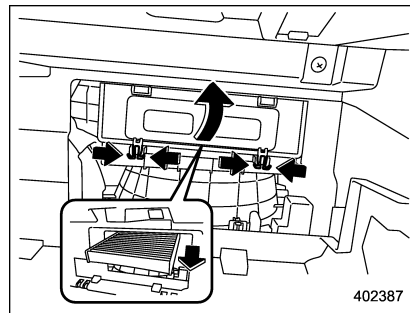

2. Remove the cabin air filter according to the following procedure in order to prevent dust on the air cleaner from falling to the inside of its housing.

- (1) Pinch both tabs and remove the filter cover.
- (2) Gently tilt down the end of the filter and slowly pull it out 0.4 in (1 cm).
- (3) Slowly pull out the rest of the filter.

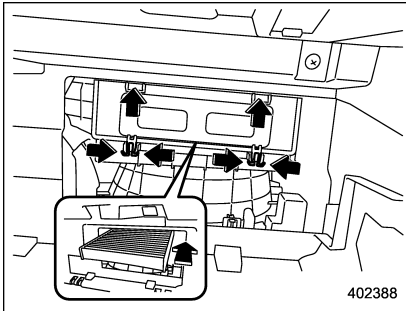

3. Replace the cabin air filter with a new one and then reinstall the cover.

CAUTION

The arrow mark on the filter must point UP.

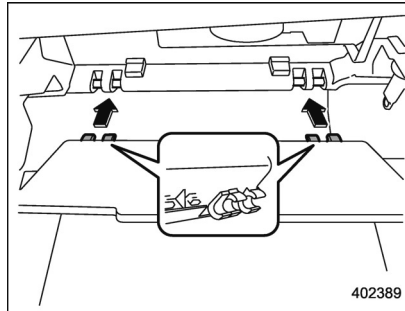

4. Reinstall the glove box, and connect the damper shaft.
5. Close the glove box.

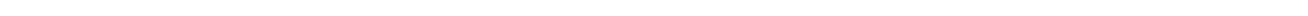
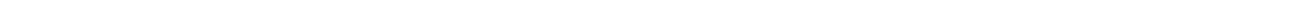
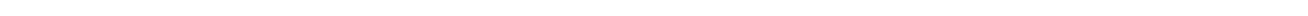
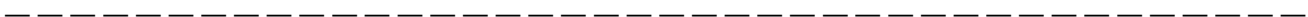
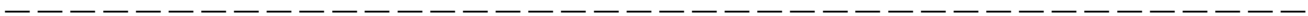
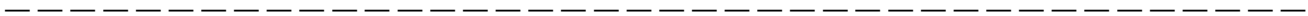

Antenna.....	5-2
Roof antenna (for Rod type)	5-2

Roof antenna (for Shark fin type)	5-2
Audio set.....	5-3

Antenna

■ Roof antenna (for Rod type)

⚠ CAUTION

- Be sure to remove the antenna rod before entering garages, parking towers and other locations with low ceilings.
- Remove the antenna rod before washing your car at a car wash. If the antenna rod remains attached, it may scratch the roof.
- When reinstalling the removed antenna rod, be sure to fully tighten it.

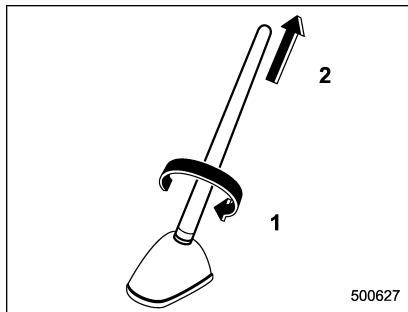

- 1) Unscrew
- 2) Remove

The roof antenna is installed in the center at the rear part of the roof.

The antenna rod can be removed by unscrewing it from its base.

■ Roof antenna (for Shark fin type)

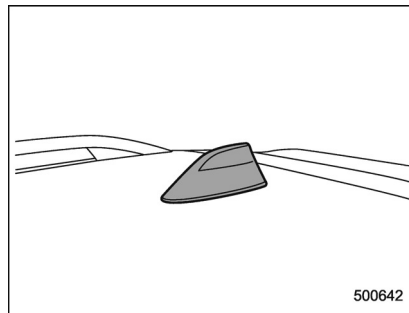

The roof antenna is installed in the center of the roof at the rear.

Audio set

If your vehicle is equipped with a genuine SUBARU navigation system or audio system, refer to the separate navigation/audio Owner's Manual for details.

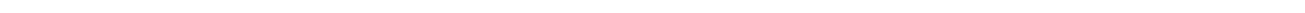
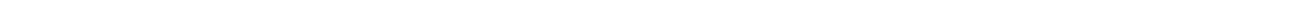
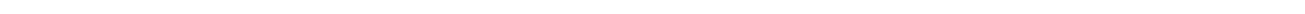
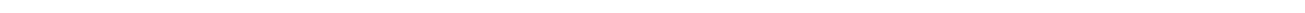
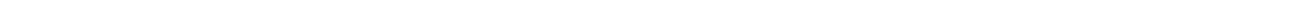
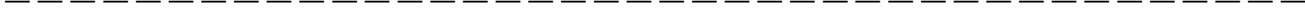
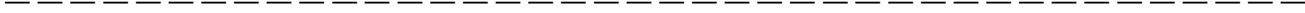
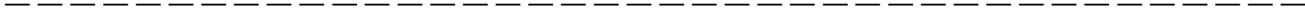
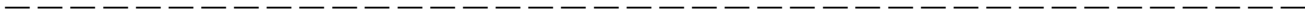
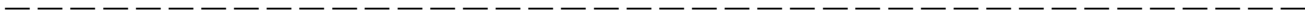
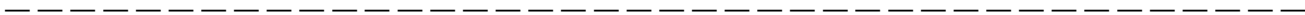

Interior lights	6-2	Ashtray (dealer option)	6-9
Map lights	6-2	Floor mat	6-10
Dome light	6-2	Coat hook	6-10
Cargo area light (5-door models)	6-3	Shopping bag hook (5-door models)	6-11
OFF delay timer	6-3	Cargo area cover (5-door models – if equipped)	6-11
Sun visors	6-3	Using the cover	6-11
Sun visor extension plate (if equipped)	6-4	To remove the cover housing.....	6-12
Vanity mirror	6-4	Stowage of the cargo area cover.....	6-12
Vanity mirror with light (if equipped)	6-5	To install the cover housing.....	6-13
Storage compartment	6-5	Cargo tie-down hooks (5-door models – if equipped)	6-13
Glove box	6-5	Under-floor storage compartment (sedan – if equipped)	6-14
Center console.....	6-6		
Cup holders	6-6		
Bottle holders	6-6		
Accessory power outlets	6-7		
Use with a cigarette lighter (dealer option)	6-8		

Interior lights



When leaving your vehicle, make sure the lights are turned off to avoid battery discharge.

■ Map lights

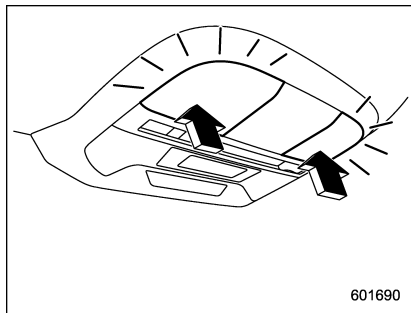

To turn on the map light, push the switch.
To turn it off, push the switch again.

▼ Automatic illumination

When the map light switch is “DOOR” position, the map lights illuminate automatically in the following cases.

- Any of the doors other than the rear gate (if equipped) is opened.
- The doors are unlocked using the keyless access function (if equipped). Refer to “Locking and unlocking by holding the access key fob” 2-8.
- The doors are unlocked using the remote keyless entry system. Refer to “Remote keyless entry system” 2-19.
- The ignition switch is turned from the “ACC” position to the “LOCK”/“OFF” position.

■ Dome light

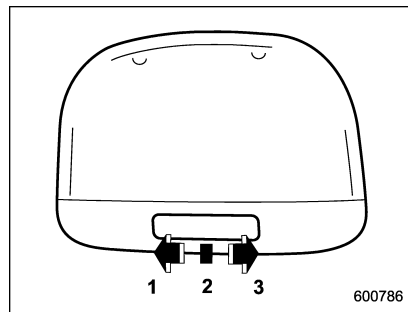

- 1) ON
- 2) DOOR
- 3) OFF

The dome light switch has the following positions.

ON: The light remains on continuously.

OFF: The light remains off.

DOOR: The dome light illuminates automatically in the following cases.

- Any of the doors or the rear gate (5-door models) is opened.
- The doors or the rear gate (5-door models) are unlocked using the keyless access function (if equipped). Refer to “Locking and unlocking by holding the access key fob” 2-8.

- The doors or the rear gate (5-door models) are unlocked using the remote keyless entry transmitter. Refer to “Remote keyless entry system” 2-19.
- The ignition switch is turned from the “ACC” position to the “LOCK”/“OFF” position.

■ Cargo area light (5-door models)

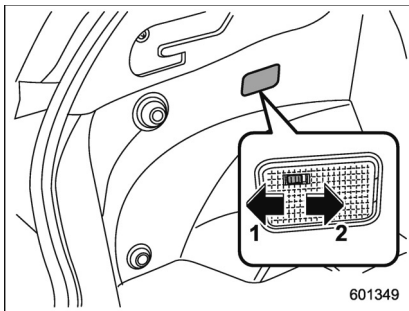

- 1) DOOR
- 2) OFF

DOOR: The light illuminates when the rear gate is opened. The light remains illuminated for several seconds and gradually turns off after the rear gate is closed.

OFF: The light remains off.

■ OFF delay timer

The following lights have an automatic illumination function.

- dome light
- map light
- cargo area light (5-door models)

When the interior light switch is set to the “DOOR” position, the light will automatically turn on and turn off depending on the locking and unlocking of the doors, the opening and closing of the doors, as well as the position of the ignition switch.

NOTE

The setting for the period of time in which the lights remain on (OFF delay timer) can be changed by a SUBARU dealer. Contact your SUBARU dealer for details. For models with the combination meter display (color LCD), the setting can also be changed by operating the combination meter display (color LCD). For details, refer to “Vehicle Setting” 3-43.

Sun visors

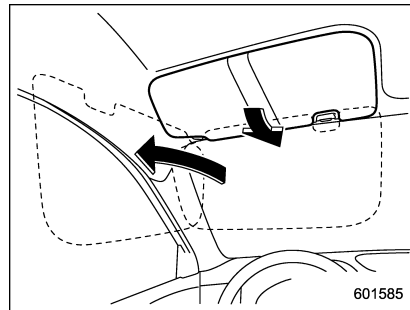

To block out glare, swing down the visors. To use the sun visor at a side window, swing it down and move it sideways.

■ Sun visor extension plate (if equipped)

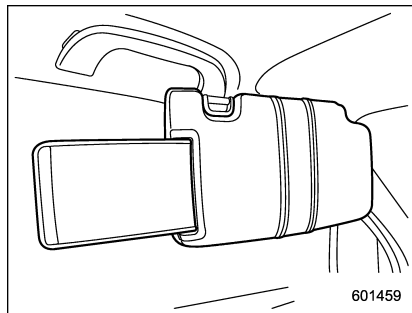

With the sun visor positioned over the side window, you can use the sun visor extension plate to prevent glare through the gap between the sun visor and center pillar. To use the extension plate, pull it toward the rear of the vehicle. When you have finished using it, stow it by pushing it toward the front of the vehicle.

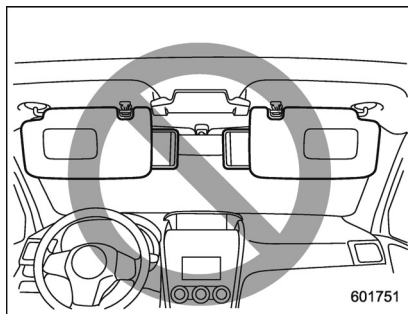

▲ CAUTION

Do not pull out the extension plate with the sun visor positioned over the windshield. The extension plate would obstruct your view of the rearview mirror.

■ Vanity mirror

▲ CAUTION

Keep the vanity mirror cover closed while the car is being driven to avoid being temporarily blinded by the glare of bright light.

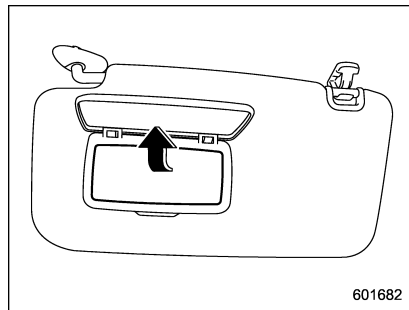

To use the vanity mirror, swing down the sun visor and open the vanity mirror cover.

■ Vanity mirror with light (if equipped)

⚠ CAUTION

Keep the vanity mirror cover closed while the car is being driven to avoid being distracted by the light.

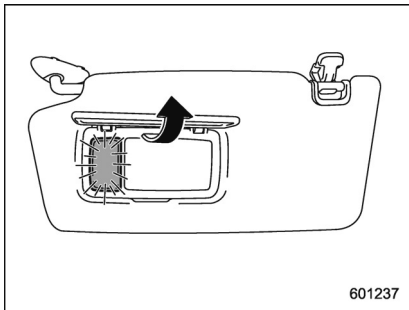

To use the vanity mirror, swing down the sun visor and open the vanity mirror cover. The light beside the vanity mirror illuminates when the mirror cover is opened.

NOTE

Use of the vanity mirror light for a long period of time while the engine is not running can cause battery discharge.

Storage compartment

⚠ CAUTION

- Always keep the storage compartment closed while driving to reduce the risk of injury in the event of a sudden stop or an accident.
- Do not store spray cans, containers with flammable or corrosive liquids or any other dangerous items in the storage compartment.

■ Glove box

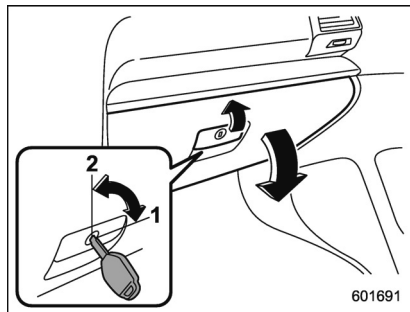

- 1) Rotate the key clockwise to lock.
- 2) Rotate the key counterclockwise to unlock.

To open the glove box, pull the handle.
To close it, push the lid firmly upward.

NOTE

- The emergency key is directional. If the key cannot be inserted, change the direction that the grooved side is facing and insert it again.
- For models with the “keyless access with push-button start system”, use the emergency key to lock or unlock the glove box.

■ Center console

The center console box provides a storage space.

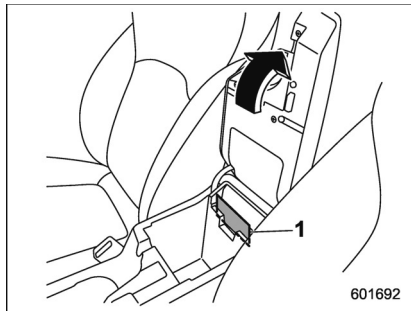

1) Card holder

The top of the console can be used as an armrest.

■ Cup holders

CAUTION

- Do not pick up a cup from the cup holder or put a cup in the holder while you are driving, as this may distract you and lead to an accident.
- Take care to avoid spills. Beverages, if hot, might scald you

and/or your passengers. Spilled beverages may also damage upholstery or carpets.

- When a cup in the rear passenger's cup holder contains a beverage, do not fold down the rear seatback. Otherwise, the beverage could spill and, if the beverage is hot, it could scald you and/or your passengers.

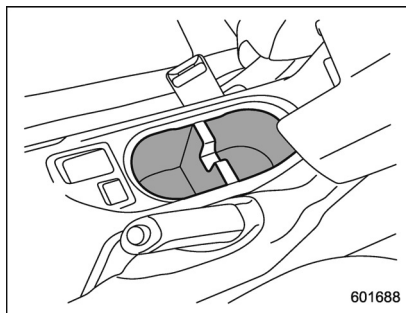

Front passenger's cup holder

A dual cup holder is built into the center console.

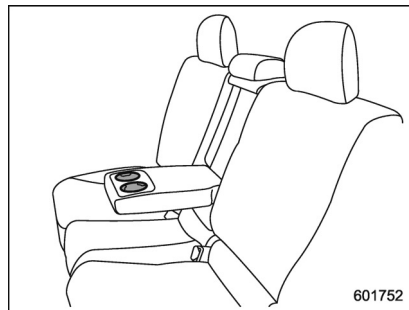

Rear passenger's cup holder (if equipped)
A dual cup holder is built into the armrest.

■ Bottle holders

CAUTION

- Do not pick up a bottle from the bottle holder or put a bottle in the holder while you are driving, as this may distract you and lead to an accident.
- When placing a beverage in a bottle holder, make sure it is capped. Otherwise, the beverage could spill when opening/closing the door or while driving and, if the beverage is hot, it could scald you and/or your passengers.

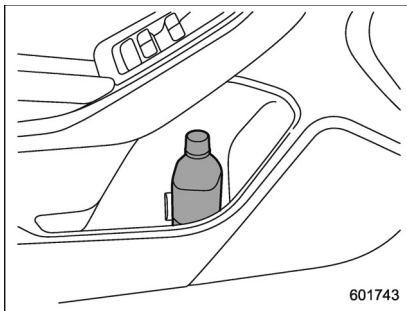

The bottle holder equipped on each door trim can be used to hold beverage bottles and other items.

Accessory power outlets

Electrical power (12V DC) is available at any of the accessory power outlets when the ignition switch is in either the "ACC" or "ON" position. Accessory power outlets are located in the following places.

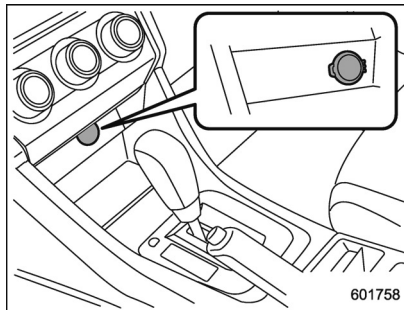

Power outlet below the climate control dials

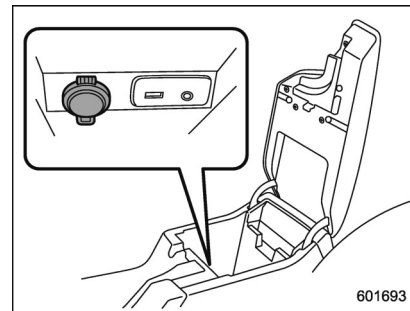

Power outlet in the center console

You can use an in-vehicle electrical appliance by connecting it to an outlet. The maximum power rating of an appliance that can be connected is **120W**.

CAUTION

- Do not attempt to use a cigarette lighter in the accessory power outlets.
- Do not place any foreign objects, especially metal ones such as coins or aluminum foil, into the accessory power outlet. That could cause a short circuit. Always put the cap on the accessory power outlet when it is not in use.

- Use only electrical appliances which are designed for 12V DC.

The maximum power rating of an appliance that can be connected is 120W. Do not use an appliance which exceeds the indicated wattage for each outlet.

- When using appliances connected to two outlets simultaneously, the total power consumed by them must not exceed 120W. Overloading the accessory power outlet can cause a short circuit. Do not use double adapters or more than one electrical appliance.
- If the plug on your electric appliance is either too loose or too tight for the accessory power outlet, this can result in a poor contact or cause the plug to get stuck. Only use plugs that fit properly.
- Use of an electric appliance in the accessory power outlet for a long period of time while the engine is not running can cause battery discharge.
- Before driving your vehicle, make sure that the plug and the cord on your electrical appliance will

not interfere with your shifting gears and operating the accelerator and brake pedals. If they do, do not use the electrical appliance while driving.

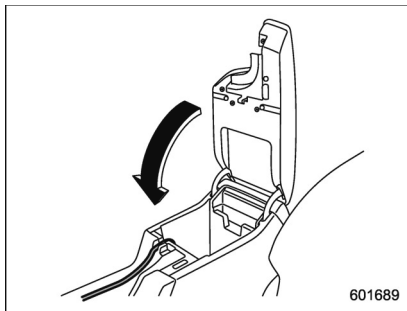

NOTE

When the lid of the center console is closed, an opening remains between the center console and the lid to allow the power outlet in the center console to be used. Pass the cord of the electrical appliance through this opening.

■ Use with a cigarette lighter (dealer option)

To use the accessory power outlet as a cigarette lighter socket, purchase a cigarette lighter plug, which is an optional accessory. A cigarette lighter plug is available from your SUBARU dealer.

The cigarette lighter operates only when the ignition switch is in the "ON" or "ACC" position.

To use the cigarette lighter, push in the knob and wait a few moments. It will automatically spring up when ready for use.



WARNING

To avoid being burned, never grasp the lighter by the end with the heating element. Doing so could result in injury and could also damage the heating element.



CAUTION

- Do not hold the lighter pushed in, because it will overheat.
- The electrical power socket is originally designed to use a genuine SUBARU cigarette lighter plug. Do not use a non-genuine

cigarette lighter plug in the socket. Doing so may cause a short-circuit and overheating, resulting in a fire.

- If the socket is ever used for a plug-in accessory such as a cell phone, that may damage the portion of the socket's internal mechanism that causes a cigarette lighter plug to "pop out" after its lighter element is heated. Therefore, do not place a cigarette lighter plug in a socket that has been used, even once, to power a plug-in accessory. Doing so may cause the plug to stick and overheat, creating a potential fire hazard.

Ashtray (dealer option)

CAUTION

- Do not use ashtrays as waste receptacles or leave a lighted cigarette in an ashtray. This could cause a fire.
- Always extinguish matches and cigarettes before putting them into the ashtray, and then close the ashtray securely. If you keep the ashtray open, the fire of the cigarette may spread to another cigarette butt and start a fire.
- Do not put flammable material in the ashtray.
- Do not leave a lot of cigarette butts in the ashtray.

NOTE

Particles of ash and tobacco will accumulate around the hinges of the ashtray's inner lid. Clean them off using a toothbrush or a similar narrow-ended implement.

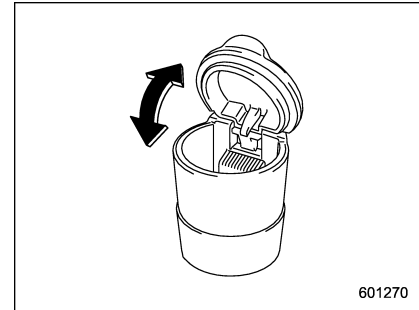

The portable ashtray can be installed in each cup holder or bottle holder. For the locations of the cup holders, refer to "Cup holders" ¶6-6. For the locations of the bottle holders, refer to "Bottle holders" ¶6-6.

When using the ashtray, open the lid of the ashtray. Fully close the lid after using the ashtray to help reduce residual smoke.

Floor mat

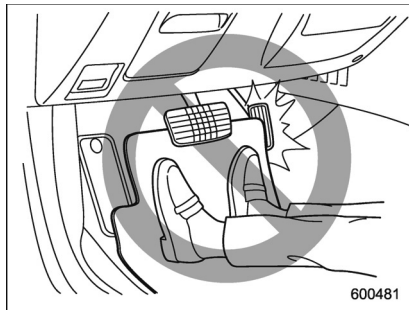

CAUTION

If the floor mat slips forward and interferes with the movement of the pedals during driving, it could cause an accident. Observe the following precautions to prevent the floor mat from slipping forward.

- Be sure to use a genuine SUBARU floor mat or an equivalent designed with grommets in the correct locations.
- Make sure that the driver's floor mat is placed in its proper location and is correctly secured on its retaining pins.

- Do not use more than one floor mat.

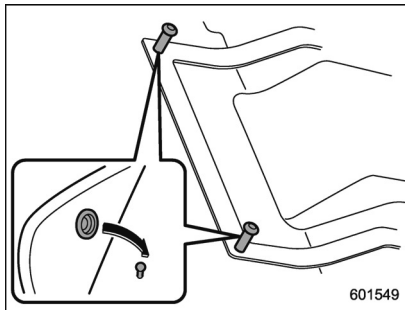

Retaining pins are located on the driver's side floor.

The floor mat should be properly secured using the built-in grommets, by placing the grommets over the pins and pushing them downward.

Coat hook

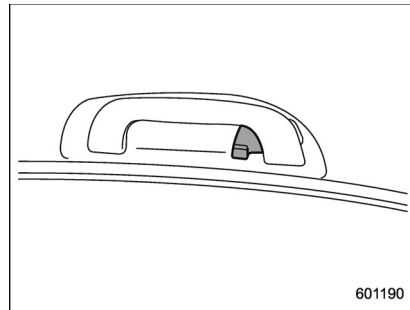

A coat hook is attached to the rear passenger's hand grip.

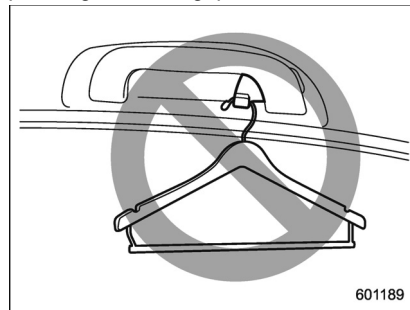

⚠ WARNING

Obey the following instructions.

- Do not hang coat hangers or other hard or pointed objects on the coat hooks. Hang clothing directly on the coat hooks without using hangers.
- Before hanging clothing on the coat hooks, make sure there are no pointed objects in the pockets.

If these instructions are ignored, the following may occur in sudden stops or in a collision.

- serious injuries by the items thrown through the cabin.
- incorrect SRS curtain airbag deployment

⚠ CAUTION

Never hang anything on the coat hook that might obstruct the driver's view or that could cause injury in sudden stops or in a collision. And do not hang items on the coat hook that weigh 11 lbs (5 kg) or more.

**Shopping bag hook
(5-door models)****⚠ CAUTION**

Do not hang items on the shopping bag hook that weigh 6 lbs (3 kg) or more.

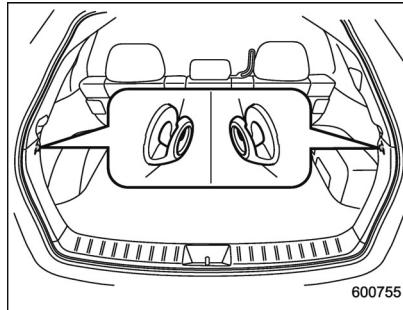

A shopping bag hook is attached to each side of the cargo area.

Cargo area cover (5-door models – if equipped)

The cargo area cover is provided for covering the cargo area and to protect its contents from direct sunlight. This cover is detachable to make room for additional cargo.

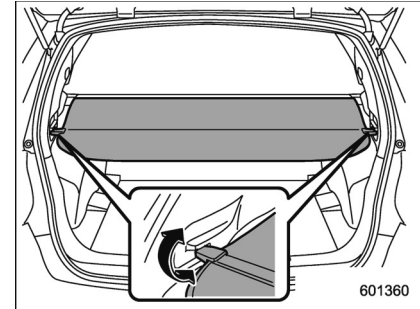
■ Using the cover

To extend the cover, pull the end of the cover out of the housing, then insert its hooks into the catches as shown. To rewind it, unhook it from the catches and it will rewind automatically. You should hold on to the cover and guide it back into the cover housing while it is rewinding.

⚠ WARNING

Do not place anything on the extended cover. Putting excessive weight on the extended cover can break it and an object on the cover could tumble forward in the event of a sudden stop or collision. This could cause serious injury.

⚠ CAUTION

Be careful not to scratch the rear gate stays while extending and rewinding the cover.

Scratches on the stays could cause leakage of gas from the stays, which may result in their inability to hold the rear gate open.

■ To remove the cover housing

1. Rewind the cover.

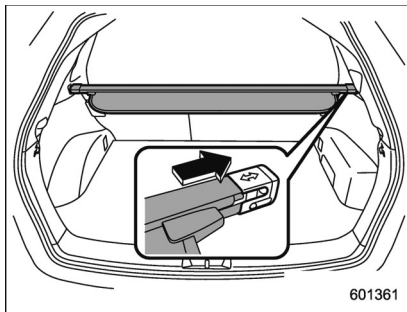

2. Push the cover housing to the right side and shorten it.
3. Take it off the retainer.

■ Stowage of the cargo area cover

The cargo area cover can be stowed under the cargo floor.

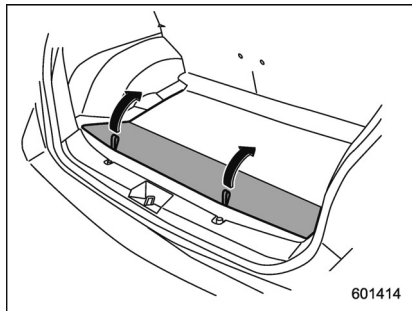

1. Raise and fold the rear end of the cargo floor board.

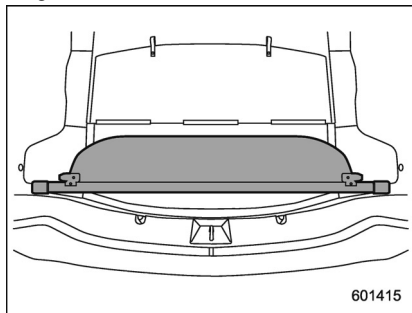

2. Stow the cover housing in the cargo area end.

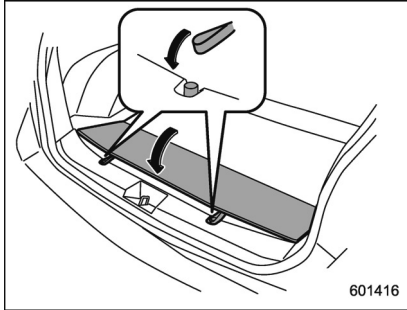

3. Put the cargo floor board back while hanging two retaining straps on the hooks that are located on the rear wall of cargo area.

■ To install the cover housing

1. Shorten the cover housing.

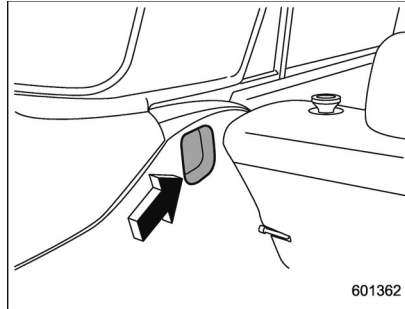

2. Insert both ends of the cover housing into the recesses of the retainers.

Cargo tie-down hooks (5-door models – if equipped)

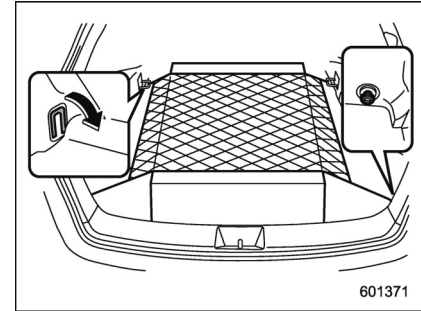

The cargo area is equipped with four tie-down hooks so that cargo can be secured with a cargo net or ropes.

When using the front tie-down hooks, turn them down out of the storing recesses.

⚠ CAUTION

The cargo tie-down hooks are designed only for securing light cargo. Never try to secure cargo that exceeds the capacity of the hooks. The maximum load capacity is 22 lbs (10 kg) per hook.

Under-floor storage compartment (sedan – if equipped)

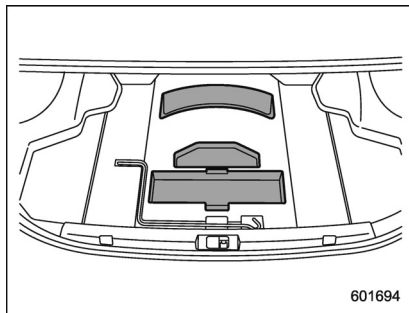

The storage compartments are located under the floor of the trunk. They can be used to store small items.

NOTE

- The shape of the storage compartment may be different depending on the model.
- When storing a flat tire, put the storage tray in the trunk.

CAUTION

- Always keep the lids closed while driving to reduce the risk of injury in the event of a sudden stop or an accident.
- Do not store spray cans, containers with flammable or corrosive liquids or any other dangerous items in the storage compartment.

Fuel	7-3	System maintenance.....	7-19
Fuel requirements	7-3	Manual transmission	7-21
Fuel filler lid and cap.....	7-4	Shifting speeds.....	7-22
State emission testing (U.S. only)	7-7	Driving tips.....	7-22
Preparing to drive	7-8	Continuously variable transmission	7-23
Starting and stopping the engine (models without push-button start system)	7-9	Continuously variable transmission features	7-23
Starting engine.....	7-9	Select lever	7-24
Stopping the engine	7-11	Selection of manual mode (if equipped).....	7-26
Starting and stopping engine (models with push-button start system)	7-12	Selection of “L” (if equipped).....	7-27
Safety precautions	7-12	Shift lock function	7-28
Operating range for push-button start system.....	7-12	Driving tips.....	7-29
Starting engine.....	7-12	Power steering	7-29
Stopping engine.....	7-14	Power steering warning light.....	7-29
When access key fob does not operate properly	7-14	Power steering system features	7-29
Remote engine start system (dealer option)	7-15	Braking	7-30
Remote engine starter transceiver (fob)	7-15	Braking tips.....	7-30
Alternate operation method for models with “keyless access with push-button start system”	7-18	Brake system	7-31
Entering the vehicle while it is running via remote start.....	7-18	Disc brake pad wear warning indicators	7-32
Entering the vehicle following remote engine start shutdown.....	7-19	ABS (Anti-lock Brake System)	7-32
Pre-heating or pre-cooling the interior of the vehicle	7-19	ABS self-check	7-33
Remote transmitter program (Remote engine starter transceiver).....	7-19	ABS warning light.....	7-33
		Electronic Brake Force Distribution (EBD) system	7-33
		Steps to take if EBD system malfunctions	7-33
		Vehicle Dynamics Control system	7-34
		Safety precautions	7-34
		System features.....	7-35
		Vehicle Dynamics Control system monitor.....	7-36
		Vehicle Dynamics Control OFF switch	7-36

Tire pressure monitoring system (TPMS)	
(U.S.-spec. models)	7-37
Parking your vehicle	7-39
Parking brake	7-39
Parking tips	7-39
Hill start assist system	7-41
To activate/deactivate the Hill start assist system	7-42
Hill start assist warning light/Hill start assist OFF indicator light	7-43
Cruise control (if equipped)	7-44
To set cruise control	7-44
To temporarily cancel the cruise control	7-45
To turn off the cruise control	7-46
To change the cruising speed	7-46
BSD/RCTA (if equipped)	7-48
System features	7-48
System operation	7-50

BSD/RCTA approach indicator light/warning	
buzzer	7-52
BSD/RCTA warning indicator	7-53
BSD/RCTA OFF switch	7-54
Certification for the BSD/RCTA	7-55
Handling of radar sensors	7-56
Reverse Automatic Braking System (if equipped)	7-57
Reverse Automatic Braking System overview	7-57
Operating conditions	7-58
Reverse Automatic Braking System operation	7-60
Canceling the Reverse Automatic Braking system operation	7-63
Reverse Automatic Braking system ON/OFF setting	7-63
RAB warning indicator	7-64
Handling of the sonar sensors	7-65

Fuel

CAUTION

Use of a fuel which is low in quality or use of an inappropriate fuel additive may cause damage to the engine and/or fuel system.

■ Fuel requirements

The engine is designed to operate using **unleaded gasoline** with an octane rating of **87 AKI (90 RON) or higher**.

▼ Fuel octane rating

Using a gasoline with a lower octane rating can cause persistent and heavy knocking, which can damage the engine. Do not be concerned if your vehicle sometimes knocks lightly when you drive up a hill or when you accelerate. Contact your SUBARU dealer if you use a fuel with the specified octane rating and your vehicle knocks heavily or persistently.

▽ RON

This octane rating is the Research Octane Number.

▽ AKI

This octane rating is the average of the Research Octane and Motor Octane numbers and is commonly referred to as the Anti Knock Index (AKI).

▼ Unleaded gasoline

The neck of the fuel filler pipe is designed to accept only an unleaded gasoline filler nozzle. Under no circumstances should leaded gasoline be used because it will damage the emission control system and may impair driveability and fuel economy.

▼ Gasoline for California-certified LEV

If your vehicle was certified to California's low emission vehicle (LEV) standards as indicated on the underhood tune-up label, it is designed to optimize engine and emission performance with gasoline that meets the clean burning low-sulfur California gasoline specifications. If you live in any other state than California, your vehicle will operate on gasoline meeting Federal specifications. Gasoline sold outside California is permitted to have higher sulfur levels, which may affect the performance of your vehicle's catalytic converter and may produce a sulfur exhaust odor or smell. SUBARU recommends that you try a different brand of unleaded gasoline having lower sulfur to determine if the

problem is fuel related before returning your vehicle to an authorized dealer for service.

▼ MMT

Some gasoline contains an octane-enhancing additive called MMT (Methylcyclopentadienyl Manganese Tricarbonyl). If you use such fuels, your emission control system performance may deteriorate and the CHECK ENGINE warning light/Malfunction indicator light may turn on. If this happens, return to your authorized SUBARU Dealer for service. If it is determined that the condition is caused by the type of fuel used, repairs may not be covered by your warranty.

▼ Gasoline for cleaner air

Your use of gasoline with detergent additives will help prevent deposits from forming in your engine and fuel system. This helps keep your engine in tune and your emission control system working properly, and is a way of doing your part for cleaner air. If you continuously use a high quality fuel with the proper detergent and other additives, you should never need to add any fuel system cleaning agents to your fuel tank.

Many gasolines are now blended with materials called oxygenates. Use of these fuels can also help keep the air cleaner.

Oxygenated blend fuels, such as MTBE (Methyl Tertiary Butyl ether) or ethanol (ethyl or grain alcohol) may be used in your vehicle, but should contain no more than 15% MTBE or 10% ethanol for the proper operation of your SUBARU.

Do not use any gasoline that contains more than 10% ethanol, including from any pump labeled E15, E30, E50 or E85 (which are only some examples of fuel containing more than 10% ethanol).

In addition, some gasoline suppliers are now producing reformulated gasolines, which are designed to reduce vehicle emissions. SUBARU approves the use of reformulated gasoline.

If you are not sure what the fuel contains, you should ask your service station operators if their gasolines contain detergents and oxygenates and if they have been reformulated to reduce vehicle emissions.

As additional guidance, only use fuels suited for your vehicle as explained in the following description.

- Fuel should be unleaded and have an octane rating no lower than that specified in this manual.
- Methanol (methyl or wood alcohol) is sometimes mixed with unleaded gasoline.

Methanol can be used in your vehicle **ONLY** if it does not exceed 5% of the fuel mixture **AND** if it is accompanied by sufficient quantities of the proper cosolvents and corrosion inhibitors required to prevent damage to the fuel system. Do not use fuel containing methanol **EXCEPT** under these conditions.

- If undesirable driveability problems are experienced and you suspect they may be fuel related, try a different brand of gasoline before seeking service at your SUBARU dealer.
- Fuel system damage or driveability problems which result from the use of improper fuel are not covered under the SUBARU Limited Warranty.

CAUTION

Do not let fuel spill on the exterior surfaces of the vehicle. Because fuel may damage the paint, be sure to wipe off any spilled fuel quickly. Paint damage caused by spilled fuel is not covered under the SUBARU Limited Warranty.

■ Fuel filler lid and cap

▼ Locations of the fuel filler lid and the lid release lever

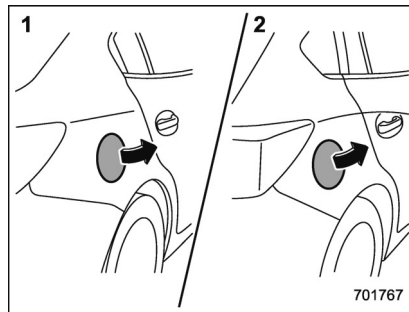

Fuel filler lid

- 1) Sedan
- 2) 5-door models

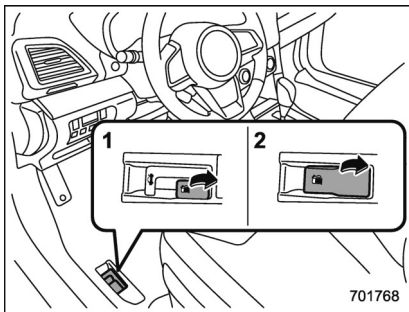

Fuel filler lid release lever

- 1) Sedan
- 2) 5-door models

▼ Refueling

Only one person should be involved in refueling. Do not allow others to approach the area of the vehicle near the fuel filler pipe while refueling is in progress.

Be sure to observe any other precautions that are posted at the service station.

1. Stop the vehicle and turn the ignition switch to the "LOCK"/"OFF" position and turn off all the other electrical components.
2. To open the fuel filler lid, pull the lid release lever up. The lever is on the floor at the left of the driver's seat.

⚠ WARNING

Before opening the fuel filler cap, first touch the vehicle body or a metal portion of the fuel pump or similar object to discharge any static electricity that may be present on your body. If your body is carrying an electrostatic charge, there is a possibility that an electric spark could ignite the fuel, which could burn you. To avoid acquiring a new static electric charge, do not get back into the vehicle while refueling is in progress.

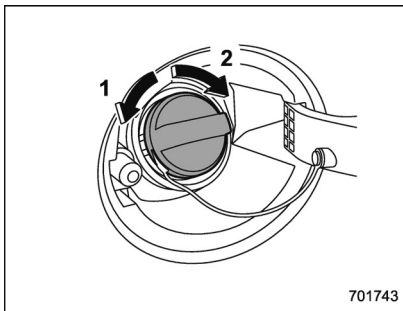

- 1) Open
- 2) Close

3. Remove the fuel filler cap by turning it

slowly counterclockwise.

⚠ WARNING

- Gasoline vapor is highly flammable. Before refueling, always turn the ignition switch to the "LOCK"/"OFF" position first and then close all vehicle doors and windows. Make sure that there are no lighted cigarettes, open flames or electrical sparks in the adjacent area. Only handle fuel outdoors. Quickly wipe up any spilled fuel.
- When opening the cap, grasp it firmly and turn it slowly to the left. Do not remove the cap quickly. Fuel may be under pressure and spray out of the fuel filler neck, especially in hot weather. If you hear a hissing sound while you are removing the cap, wait for the sound to stop and then slowly open the cap to prevent fuel from spraying out and creating a fire hazard.

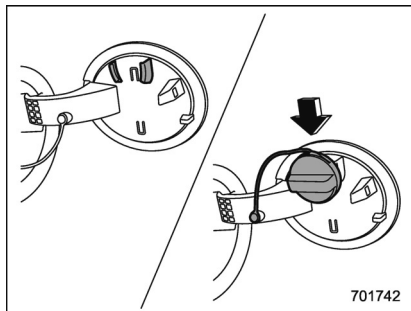

701742

4. Set the fuel filler cap on the cap holder inside the fuel filler lid.

WARNING

- When refueling, insert the fuel nozzle securely into the fuel filler pipe. If the nozzle is lifted or not fully inserted, its automatic stopping mechanism may not function, causing fuel to overflow the tank and creating a fire hazard.

- Stop refueling when the automatic stop mechanism on the fuel nozzle activates. If you continue to add fuel, temperature changes or other conditions may cause fuel to overflow from the tank and create a fire hazard.

5. Stop filling the tank after the fuel filler pump automatically stops. Do not add any more fuel.

6. Put the cap back on, turn it clockwise until you hear a clicking noise. Be certain not to catch the tether under the cap while tightening.

CAUTION



Make sure that the cap is tightened until it clicks to prevent fuel spillage in the event of an accident.

7. Close the fuel filler lid completely.

CAUTION

If you spill any fuel on the painted surface, rinse it off immediately. Otherwise, the painted surface could be damaged.

NOTE

- You will see the “” sign in the fuel gauge. This indicates that the fuel filler door (lid) is located on the right side of the vehicle.
- If the fuel filler cap is not tightened until it clicks or if the tether is caught under the cap, the CHECK ENGINE warning light/malfunction indicator light may illuminate. Refer to “CHECK ENGINE warning light/Malfunction indicator light”  3-16.

CAUTION

- Never add any cleaning agents to the fuel tank. The addition of a cleaning agent may cause damage to the fuel system.
- After refueling, turn the cap to the right until it clicks to ensure that it is fully tightened. If the cap is not securely tightened, fuel may leak out while the vehicle is being driven or fuel spillage could occur in the event of an accident, creating a fire hazard.
- Do not let fuel spill on the exterior surfaces of the vehicle. Because fuel may damage the paint, be sure to wipe off any spilled fuel quickly. Paint damage caused by

spilled fuel is not covered under the SUBARU Limited Warranty.

- Always use a genuine SUBARU fuel filler cap. If you use the wrong cap, it may not fit or have proper venting and your fuel tank and emission control system may be damaged. It could also lead to fuel spillage and a fire.
- Immediately put fuel in the tank whenever the low fuel warning light illuminates. Engine misfires as a result of an empty tank could cause damage to the engine. Continuing to operate your vehicle at an extremely low fuel level may result in a reduction of engine performance.

State emission testing (U.S. only)

WARNING

Only use a four-wheel dynamometer when testing an AWD model.

Testing of an All-Wheel Drive model must NEVER be performed on a single two-wheel dynamometer. Attempting to do so will result in uncontrolled vehicle movement and may cause an accident or injuries to persons nearby.

CAUTION

- At state inspection time, remember to tell your inspection or service station in advance not to place your SUBARU AWD vehicle on a two-wheel dynamometer. Otherwise, serious transmission damage will result.
- Resultant vehicle damage due to improper testing is not covered under the SUBARU Limited Warranty and is the responsibility of the state inspection program or its contractors or licensees.

California and a number of federal states have Inspection/Maintenance programs to inspect your vehicle's emission control system. If your vehicle does not pass this test, some states may deny renewal of your vehicle's registration.

Your vehicle is equipped with a computer that monitors the performance of the engine's emission control system. Certified emission inspectors will inspect the On-Board Diagnostic (OBDII) system as part of the state emission inspection process. The OBDII system is designed to detect engine and transmission problems that might cause the vehicle emissions to exceed allowable limits. OBDII inspections apply to all 1996 model year and newer passenger cars and trucks. Over 30 states plus the District of Columbia have implemented emission inspection of the OBDII system.

- The inspection of the OBDII system consists of a visual operational check of the "CHECK ENGINE" warning light/malfunction indicator light (MIL) and an examination of the OBDII system with an electronic scan tool.
- A vehicle passes the OBDII system inspection if proper operation of the "CHECK ENGINE" warning light is observed, there are no stored diagnostic trouble codes, and the OBDII readiness

monitors are all complete.

- A vehicle fails the OBDII inspection if the “**CHECK ENGINE**” warning light is not properly operating (light is illuminated or is not working due to faulty LED [Light Emitting Diode]) or there is one or more diagnostic trouble codes stored in the vehicle’s computer.

- A state emission inspection may reject (not pass or fail) a vehicle if the number of OBDII system readiness monitors “**NOT READY**” is greater than one. If the vehicle’s battery has been recently replaced or disconnected, the OBDII system inspection may indicate that the vehicle is not ready for the emission test. Under this condition, the vehicle driver should be instructed to drive his/her vehicle for a few days to reset the readiness monitors and return for an emission re-inspection.

- Owners of rejected or failing vehicles should contact their SUBARU Dealer for service.

Some states still use dynamometers in their emission inspection program. A dynamometer is a treadmill or roller-like testing device that allows your vehicle’s wheels to turn while the vehicle remains in one place. Prior to your vehicle being put on a dynamometer, tell your emission inspector not to place your SUBARU

AWD vehicle on a two-wheel dynamometer. **Otherwise, serious transmission damage will result.**

The U.S. Environmental Protection Agency (EPA) and states using two-wheel dynamometers in their emission testing program have EXEMPTED SUBARU AWD vehicles from the portion of the testing program that involves a two-wheel dynamometer. There are some states that use four-wheel dynamometers in their testing program. When properly used, this equipment should not damage a SUBARU AWD vehicle.

Under no circumstances should the rear wheels be jacked off the ground, nor should the driveshaft be disconnected in attempt to cancel AWD for state emission testing. AWD vehicles must be tested with all 4 wheels driven and loaded.

Preparing to drive

You should perform the following checks and adjustments every day before you start driving.

1. Check that all windows, mirrors, and lights are clean and unobstructed.
2. Check the appearance and condition of the tires. Also check tires for proper inflation.
3. Look under the vehicle for any sign of leaks.
4. Check that no small animals enter the engine compartment.
5. Check that the hood, trunk (sedan) and rear gate (5-door models) are fully closed.
6. Check the adjustment of the seat.
7. Check the adjustment of the inside and outside mirrors.
8. Fasten your seatbelt. Check that your passengers have fastened their seatbelts.
9. Check the operation of the warning and indicator lights when the ignition switch is turned to the “ON” position.
10. Check the gauges, indicator and warning lights after starting the engine.

 **CAUTION**

Trapping small animals in the cooling fan and belts of the engine may result in a malfunction. Check that no small animal enters the engine compartment and under the vehicle before starting the engine.

NOTE

Engine oil, engine coolant, brake fluid, washer fluid and other fluid levels should be checked daily, weekly or at fuel stops.

Starting and stopping the engine (models without push-button start system)

 **CAUTION**

Do not operate the starter motor continuously for more than 10 seconds. If the engine fails to start after operating the starter for 5 to 10 seconds, wait for 10 seconds or more before trying again.

NOTE

It may be difficult to start the engine when the battery has been disconnected and reconnected (for maintenance or other purposes). This difficulty is caused by the electronically controlled throttle's self-diagnosis function. To overcome it, keep the ignition switch in the "ON" position for approximately 10 seconds before starting the engine.

■ **Starting engine**

▼ **General precautions when starting engine**

 **WARNING**

- Never start the engine from outside the vehicle (except when using the remote engine start system). It may result in an accident.
- Do not leave the engine running in locations with poor ventilation, such as a garage and indoors. The exhaust gas may enter the vehicle or indoors, and it may result in carbon monoxide poisoning.
- Do not start the engine near dry foliage, paper, or other flammable substances. The exhaust pipe and exhaust emissions can create a fire hazard at high temperatures.

 **CAUTION**

- If the engine is stopped during driving, the catalyst may overheat and burn.

- When starting the engine, be sure to sit in the driver's seat (except when using the remote engine start system).

NOTE

- Avoid rapid racing and rapid acceleration immediately after the engine has started.
- For a short time after the engine has started, the engine speed is kept high. When the warm-up is completed, the engine speed lowers automatically.
- On rare occasions, it may be difficult to start the engine depending on the fuel and the usage condition (repeated driving of a distance in which the engine has not warmed up sufficiently). In such a case, it is recommended that you change to a different brand of fuel.
- On rare occasions, transient knocking may be heard from the engine when the accelerator is operated rapidly such as a rapid start-up and a rapid acceleration. This is not a malfunction.
- The engine starts more easily when the headlights, air conditioner and rear window defogger are turned off.

▼ MT models

1. Apply the parking brake.
2. Turn off unnecessary lights and accessories.
3. Depress the clutch pedal to the floor and shift the shift lever into neutral. Hold the clutch pedal to the floor while starting the engine.

The starter motor will only operate when the clutch pedal is depressed fully to the floor.

4. Turn the ignition switch to the "ON" position and check the operation of the warning and indicator lights. Refer to "Warning and indicator" 3-13.
5. Turn the ignition switch to the "START" position **without** depressing the accelerator pedal. Release the key immediately after the engine has started.

If the engine does not start, try the following procedure.

- (1) Turn the ignition switch to the "LOCK"/"OFF" position and wait for at least 10 seconds. After checking that the parking brake is firmly set, turn the ignition switch to the "START" position while depressing the accelerator pedal slightly (approximately a quarter of the full stroke). Release the accelerator pedal as soon as the engine starts.
- (2) If this fails to start the engine, turn

the ignition switch back to the "LOCK"/"OFF" position and wait for at least 10 seconds. Then fully depress the accelerator pedal and turn the ignition switch to the "START" position. If the engine starts, quickly release the accelerator pedal.

(3) If this fails to start the engine, turn the ignition switch again to the "LOCK"/"OFF" position. After waiting for 10 seconds or longer, turn the ignition switch to the "START" position without depressing the accelerator pedal.

(4) If the engine still fails to start, contact your nearest SUBARU dealer for assistance.

6. Confirm that all warning and indicator lights have turned off after the engine has started. The fuel injection system automatically lowers the idle speed as the engine warms up.

▼ CVT models

1. Apply the parking brake.
2. Turn off unnecessary lights and accessories.
3. Shift the select lever to the "P" or "N" position (preferably the "P" position). The starter motor will only operate when the select lever is at the "P" or "N" position.

4. Turn the ignition switch to the "ON" position and check the operation of the warning and indicator lights. Refer to "Warning and indicator" 3-13.
5. Turn the ignition switch to the "START" position **without** depressing the accelerator pedal. Release the key immediately after the engine has started.

If the engine does not start, try the following procedure.

(1) Turn the ignition switch to the "LOCK"/"OFF" position and wait for at least 10 seconds. After checking that the parking brake is firmly set, turn the ignition switch to the "START" position while depressing the accelerator pedal slightly (approximately a quarter of the full stroke). Release the accelerator pedal as soon as the engine starts.

(2) If this fails to start the engine, turn the ignition switch back to the "LOCK"/"OFF" position and wait for at least 10 seconds. Then fully depress the accelerator pedal and turn the ignition switch to the "START" position. If the engine starts, quickly release the accelerator pedal.

(3) If this fails to start the engine, turn the ignition switch again to the "LOCK"/"OFF" position. After waiting for 10 seconds or longer, turn the ignition switch to the "START" position

without depressing the accelerator pedal.

(4) If the engine still refuses to start, contact your nearest SUBARU dealer for assistance.

6. Confirm that all warning and indicator lights have turned off after the engine has started. The fuel injection system automatically lowers the idle speed as the engine warms up.

While the engine is warming up, make sure that the select lever is at the "P" or "N" position and that the parking brake is applied.

CAUTION

If you restart the engine while the vehicle is moving, shift the select lever into the "N" position. Do not attempt to place the select lever of a moving vehicle into the "P" position.

■ Stopping the engine

The ignition switch should be turned off only when the vehicle is stopped and the engine is idling.

WARNING

Do not stop the engine when the vehicle is moving. This will cause loss of power to the power steering and the brake booster, making steering and braking more difficult. It could also result in accidental activation of the "LOCK"/"OFF" position on the ignition switch, causing the steering wheel to lock.

Starting and stopping engine (models with push-button start system)

■ Safety precautions

Refer to "Safety precautions" 2-4.

■ Operating range for push-button start system

Refer to "Operating range for push-button start system" 3-6.

■ Starting engine



WARNING

- There are some general precautions when starting the engine. Carefully read the precautions described in "Starting engine" 7-9.
- If the indicator on the push-button ignition switch flashes in green after the engine has started, never drive the vehicle. The steering is still locked, and it may result in an accident.



CAUTION

- When the operation indicator on the push-button ignition switch is flashing in orange, there may be a malfunction with the vehicle. Contact a SUBARU dealer immediately.
- If the indicator on the push-button ignition switch is flashing in green after the engine has started, it means that the steering is still locked. Depress the brake pedal while moving the steering wheel to the right and left, and press the push-button ignition switch.
- Do not continue pushing the push-button ignition switch for more than 10 seconds. Doing so could cause a malfunction. If the engine does not start, stop pushing the push-button ignition switch. Instead, press the push-button ignition switch without depressing the brake pedal to switch the power status to "OFF". Wait 10 seconds, and then push the push-button ignition switch to start the engine.

NOTE

- For a short time after the engine has started, the engine speed is kept high. When the warm-up is completed, the engine speed lowers automatically.
- When the push-button ignition switch is pressed while depressing the clutch pedal (MT models) or the brake pedal (CVT models), the engine starter operates for a maximum of 10 seconds and after starting the engine, the starter stops automatically.
- When the push-button ignition switch is pressed while depressing the clutch pedal (MT models) or the brake pedal (CVT models), the engine can be started regardless of the status of the push-button ignition switch.
- If the security indicator light illuminates when you attempt to start the engine but the engine does not start, press the push-button ignition switch to switch the power to "OFF" and then try to start the engine again.
- If the engine does not start, press the push-button ignition switch without depressing the clutch pedal (MT models) or the brake pedal (CVT models) to switch the power to "OFF". Then, while depressing the clutch pedal (MT models) or the brake pedal (CVT models) more forcefully, press the push-button

ignition switch.

- The engine start procedures may not function depending on the radio wave conditions around the vehicle. In such a case, refer to “Starting engine” 9-19.

- If the vehicle battery is discharged, the steering cannot be unlocked. Charge the battery.

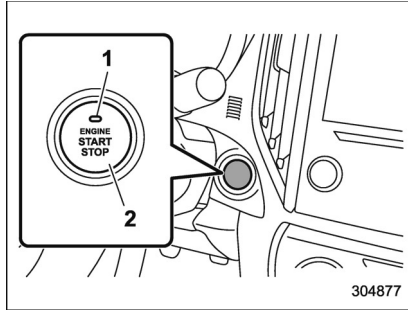

- 1) Operation indicator
- 2) Push-button ignition switch

When the push-button ignition switch is pressed while depressing the clutch pedal (MT models) or the brake pedal (CVT models), the engine will start. The starting procedure for the engine is as follows.

▼ MT models

1. Carry the access key fob, and sit in the driver's seat.
2. Apply the parking brake.
3. Shift the shift lever in neutral.
4. Depress the brake pedal.
5. Depress the clutch pedal until the indicator on the push-button ignition switch turns green.
6. While depressing the clutch pedal, press the push-button ignition switch.

NOTE

In case the engine does not start by the normal engine start procedure, move the shift lever to the neutral position, and switch the power to “ACC”. Depress the clutch pedal, and press the push-button ignition switch for at least 15 seconds. The engine may start. Only use this engine start procedure in case of emergency.

▼ CVT models

1. Carry the access key fob, and sit in the driver's seat.
2. Apply the parking brake.
3. Shift the select lever into the “P” position. The engine can also start when the select lever is in the “N” position,

however, for safety reasons, start in the “P” position.

4. Depress the brake pedal until the operation indicator on the push-button ignition switch turns green. When starting with the select lever in the “N” position, the indicator does not turn green.
5. While depressing the brake pedal, press the push-button ignition switch.

NOTE

- While pressing the select lever button in, the indicator on the push-button ignition switch will not turn green even when the select lever is in the “P” position.

- In case the engine does not start by the normal engine start procedure, move the select lever to the “P” position, and switch the power to “ACC”. Depress the brake pedal, and press the push-button ignition switch for at least 15 seconds. The engine may start. Only use this engine start procedure in case of emergency.

- When the engine is not started, the brake pedal may feel stiff. In such a case, depress the brake pedal more forcefully than usual. Check that the operation indicator on the push-button ignition switch turns green, and press the push-button ignition switch to start

the engine.

■ Stopping engine

1. Stop the vehicle completely.
2. Move the select lever to the “P” position (CVT models).
3. Press the push-button ignition switch. The engine will stop, and the power will be switched off.

WARNING

- Do not touch the push-button ignition switch during driving.

When the push-button ignition switch is operated as follows, the engine will stop.

- The switch is pressed and held for 3 seconds or longer.
- The switch is pressed briefly 3 times or more in succession.

When the engine stops, the brake booster will not function. A greater foot pressure will be required on the brake pedal.

The power steering system will not operate either. A greater force will be required to steer, and it may result in an accident.

- If the engine stops during driving,

do not operate the push-button ignition switch or open any of the doors until the vehicle is stopped in a safe location. It is dangerous because the steering lock may be activated. Stop the vehicle in a safe place, and contact a SUBARU dealer immediately.

CAUTION

For CVT models

- Do not stop the engine while the select lever is in a position other than the “P” position.
- If the engine is stopped while the select lever is in a position other than the “P” position, the power will be in “ACC”. If the vehicle is left in this condition, the battery may be discharged.

NOTE

Although you can stop the engine by operating the push-button ignition switch, do not stop the engine during driving except in an emergency.

■ When access key fob does not operate properly

Refer to “Access key fob – if access key fob does not operate properly” 9-18.

Remote engine start system (dealer option)

WARNING

- There are some general precautions when starting the engine. Carefully read the precautions described in “General precautions when starting engine” 7-9.
- Do not remote start a vehicle in an enclosed environment (e.g. closed garage). Prolonged operation of a motor vehicle in an enclosed environment can cause a harmful build-up of Carbon Monoxide. Carbon Monoxide is harmful to your health. Exposure to high levels of Carbon Monoxide can cause headaches, dizziness or in extreme cases unconsciousness and/or death.

The remote engine start system allows you to start the engine from outside the vehicle. In addition, the remote engine start system can activate the heater or air conditioner, providing you with a comfortable cabin upon entry. For more details, refer to the Owner's Manual supplement

for the remote engine start system.

NOTE

- The length of time for which it is acceptable to allow the engine to remain idling may be bound by local laws and regulations. Check the local rules when using the remote engine start system.
- When taking your vehicle in for service, it is recommended that you inform the service personnel that your vehicle is equipped with a remote engine start system.

Remote engine starter transceiver (fob)

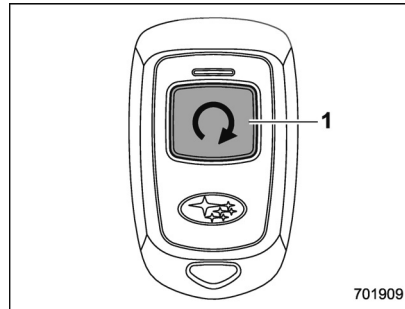

1) Fob button

Starting the engine

NOTE

All vehicle doors (including rear gate/trunk lid) and the engine hood must be closed prior to activating the remote engine start system. Any open entry point will prevent starting or cause the engine to stop.

The remote engine start system is activated by pressing the fob button on your remote engine starter transceiver (fob) twice within 3 seconds. If the fob is within operating range of the system and the start request is received, the following phenomena will occur.

- The fob flashes and beeps once.
- The horn sounds once.
- The side marker lights, tail lights, and parking lights flash once.

If the fob is not within range (the user is too far away from the vehicle), the fob will indicate two long flashes without beeping.

The system will check certain safety preconditions before starting, and if all conditions are met, the engine will start within 5 seconds. After the engine starts, the following phenomena will occur.

- The fob flashes and beeps twice.
- The horn sounds once.

- The side marker lights, tail lights, and parking lights flash once.

While the engine is idling via the remote engine start system, the following phenomena will occur.

- The side marker lights, tail lights, and parking lights remain illuminated.
- The fob button flashes once every 3 seconds.
- The power windows are disabled.

If the engine turns over but does not start (or starts and stalls) the remote engine start system will power off and then attempt to start the engine 3 additional times. The system will not attempt to restart the engine if it determines a vehicle malfunction is preventing starting. If the engine does not start after 3 additional attempts, the remote engine start request will be aborted.

▼ Stopping the engine

Press and hold the fob button for at least 2 seconds to stop the engine. The fob will flash and beep three times, indicating the engine has stopped. If the stop request is not received (for example, if the user is too far away from the vehicle), the fob will continue to flash once every 3 seconds. The system will automatically stop the engine after 15 minutes.

▼ Remote start safety features

For safety and security reasons, the remote engine start system will prevent starting (or stop the engine if running) and sound the horn twice if any of the following conditions is detected. In addition, the fob will flash and beep 3 times.

- The total run-time has exceeded 20 minutes
- The brake pedal is depressed
- A key is in the ignition switch
- The engine hood is open
- The engine idle speed exceeds 3,500 RPM
- The security alarm is triggered
- The select lever is not in the "P" position (CVT models)

If the system detects any door (including the rear gate/trunk lid) open during operation, it will prevent starting or stop the engine, and sound the horn and flash side marker lights, tail lights, and parking lights 6 times.

In addition to the items above, if the vehicle's engine management system determines there is a safety risk due to a vehicle-related problem, the vehicle will power down and the horn will sound 3 times.

NOTE

- **If the alarm system is armed at the time of remote engine starter activation (the security indicator light on the combination meter is flashing), the alarm system will remain armed throughout the remote start run cycle.**
- **If the alarm system is disarmed at the time of remote engine starter activation (the security indicator light on the combination meter is not flashing), the alarm system will remain disarmed throughout the remote start run cycle.**

▼ Remote start operation - fob confirmation

Your remote engine starter fob is a bidirectional transceiver that can confirm system operation with several different visual and audible indications. The fob's LED-backlit button and internal piezo buzzer will indicate status of the system using the following flash and beep sequences, provided the fob is within operational range of the system.

Precondition	Fob Indication		Meaning
	Flash	Beep	
Fob start button is being pressed	Continuous while button is held down	—	The fob is transmitting an RF signal
User attempts to start engine by pressing fob button twice within 3 sec	1 flash	1 beep	Engine start request received
	2 flashes	2 beeps	Engine started successfully
	1 flash every 3 sec	—	Engine idling
	3 flashes	3 beeps	Vehicle is in range but engine not started
	2 long flashes	—	Vehicle not in range (engine not started)
Engine idling by remote engine start operation	1 flash every 3 sec	—	Engine idling
	3 flashes	3 beeps	Engine stopped by system timeout or for safety reasons (see sections above)
User attempts to stop engine by pressing and holding fob button for at least 2 sec.	3 flashes	3 beeps	Engine stopped by user request
	1 flash every 3 sec	—	Stop request not received. Engine still idling.

■ **Alternate operation method for models with “keyless access with push-button start system”**

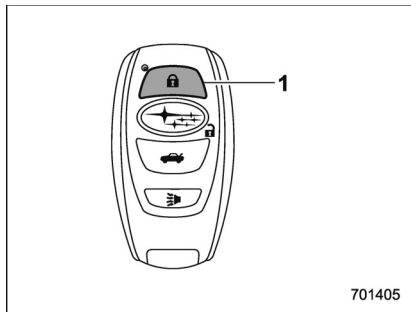

Access key fob

- 1) Lock button

An access key fob can be used as the remote engine start transmitter. Operate the lock button to start or stop the engine as follows.

▼ **Before starting the engine**

Before using the remote engine start system to start the engine, confirm the following conditions.

- The select lever is in the “P” position (CVT models).
- All doors including the rear gate are

closed.

- The engine hood is closed.
- The push-button ignition switch is in the “OFF” position.

▼ **When starting the engine**

To start the engine with remote engine start system, briefly press the lock button twice within 2 seconds, then press and hold the lock button for 3 seconds.

1. Press the lock button briefly. The hazard warning flashers then flash once and the keyless buzzer chirps once.
2. Within 2 seconds, press the lock button briefly again. The hazard warning flashers then flash once again, and the keyless buzzer chirps once again.
3. After step 2, immediately press and hold the lock button. The hazard warning flashers then flash three times, and the horn will honk once.
4. Approximately 3 seconds after step 3, release the lock button. The engine will then start successfully.

▼ **When stopping the engine**

Press and hold the lock button to stop the engine with remote engine start system.

▼ **Remote start safety features**

For details, refer to “Remote start safety features” 7-16.

■ **Entering the vehicle while it is running via remote start**

1. Unlock the vehicle doors using the keyless access function (if equipped) or remote keyless entry system.

If the vehicle’s doors are unlocked manually using the key, the vehicle’s alarm system will trigger (if the alarm system is armed prior to activating the remote engine start system) and the engine will turn off. Perform either of the following procedures to disarm the alarm system. Refer to “Alarm system” 2-26.

- Insert the key into the ignition switch and turn it to the “ON” position (models without “keyless access with push-button start system”)
 - Turn the push-button ignition switch to the “ACC” or “ON” position (models with “keyless access with push-button start system”)
 - Press any button on the access key fob/remote keyless entry transmitter.
2. Enter the vehicle.
 3. The engine will shut down when any door or trunk/rear gate is opened.
 4. Insert the key into the ignition switch

and turn to the "START" position to restart the engine.

■ Entering the vehicle following remote engine start shutdown

An alarm trigger may occur if the vehicle is opened by the remote keyless entry transmitter within a few seconds immediately following remote engine start shutdown.

■ Pre-heating or pre-cooling the interior of the vehicle

Before exiting the vehicle, set the temperature controls to the desired setting and operation. After the system starts the engine, the heater or air conditioning will activate and heat or cool the interior to your setting.

■ Remote transmitter program (Remote engine starter transceiver)

New transmitters can be programmed to the remote engine start system in the event that a transmitter is lost, stolen, damaged or additional transmitters are desired (the system will accept up to eight transmitters). New remote engine start transmitters can be programmed accord-

ing to the following procedure.

1. Open the driver's door (the driver's door must remain opened throughout the entire process).
2. Depress and hold the brake pedal.
3. Turn the ignition switch to "ON" then "LOCK"/"OFF", back to "ON" then "LOCK"/"OFF", back to "ON" then "LOCK"/"OFF", then back to "ON" again and leave the ignition "ON" throughout the programming process.
4. The system will flash the side marker lights, tail lights and parking lights and honk the horn three times, indicating that the system has entered the transmitter learn mode.
5. Press and release the "Q" button on the transmitter that you want to program.
6. The system will flash the side marker lights, tail lights and parking lights and honk the horn one time, indicating that the system has learned the transmitter. Upon successful programming, the remote start confirmation transmitter button will flash one time.
7. Repeat step 5 for any additional transmitters (the system will accept up to eight transmitters).
8. The system will exit the transmitter learn mode if the key is turned to the "LOCK"/"OFF" position, the door is closed

or after 2 minutes.

■ System maintenance NOTE

For remote engine starter transceiver:
In the event that the vehicle's battery is replaced, discharged or disconnected, it will be necessary to start the vehicle a minimum of one time using the key prior to activating the remote engine start system. This is required to allow the vehicle electronic systems to re-synchronize.

▼ Changing the battery



CAUTION

- Do not let dust, oil or water get on or in the remote engine start transmitter when replacing the battery.
- Be careful not to damage the printed circuit board in the remote engine start transmitter when replacing the battery.
- Be careful not to allow children to touch the battery and any removed parts; children could swallow them.
- There is a danger of explosion if

an incorrect replacement battery is used. Replace only with the same or equivalent type of battery.

- Battery should not be exposed to excessive heat such as sunshine, fire or the like.

For models with “keyless access with push-button start system”:

Perform the procedure described in “Replacing battery of access key fob” 11-45.

For remote engine starter transceiver:

The 3-volt lithium battery (model CR-2450) supplied in your remote engine start transmitter should last approximately one year, depending on usage. When the battery begins to weaken, you will notice a decrease in range (distance from the vehicle that your remote control operates). Follow the instructions below to change the remote engine start transmitter battery.

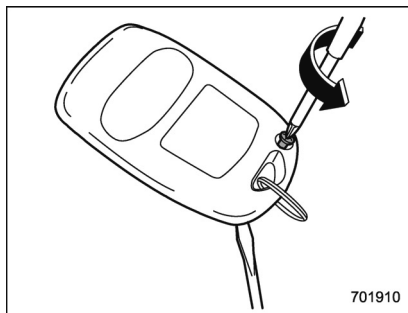

1. Remove the small Phillips screw located on the back side lower left corner of the transmitter.
2. Carefully pry the remote engine start transmitter halves apart using a small flat-head screwdriver.

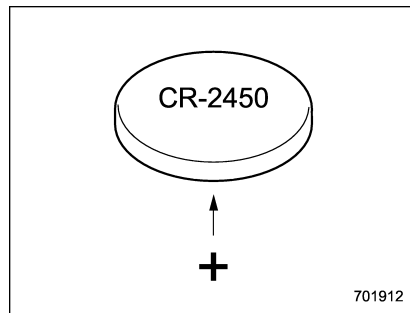
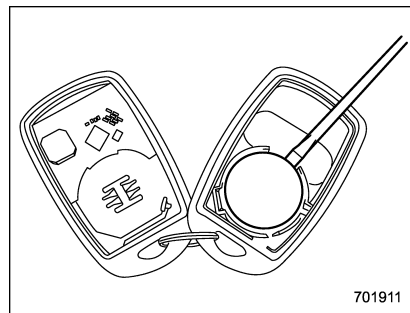

3. Remove the circuit board from the bottom half of the case and remove the battery and replace with new one. Be sure to observe the (+) sign on the old battery before removing it to ensure that the new battery is inserted properly (battery “+”

should be pointed away from the transmitter circuit board on battery).

4. Carefully snap the case halves back together, reinstall the phillips screw and test the remote engine start system.

NOTE

• This device complies with Part 15 of the FCC Rules and with RSS-210 of Industry Canada. Operation is subject to the following two conditions: (1) This device may not cause harmful interference, and (2) this device must accept any interference received, including interference that may cause undesired operation.

Changes or modifications not expressly approved by the party responsible for compliance could void the user's authority to operate the equipment and void warranty.

• To comply with the FCC RF exposure compliance requirements, no change to the antenna or the device is permitted. Any change to the antenna or the device could result in the device exceeding the RF exposure requirements and void user's authority to operate the device.

Manual transmission

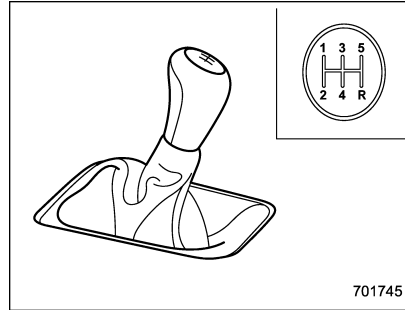

The manual transmission is a fully synchromeshed, 5-forward-speed and 1-reverse-speed transmission.

The shift pattern is shown on the shift lever knob. When shifting from 5th gear to reverse gear, first return the shift lever to the neutral position then shift into reverse gear.

To change gears, fully depress the clutch pedal, move the shift lever, and gradually let up on the clutch pedal.

If it is difficult to shift into gear, put the transmission in neutral, release the clutch pedal momentarily, and then try again.

WARNING

- Do not drive the vehicle with the clutch disengaged (i.e., when the clutch pedal is depressed) or with the shift lever in the neutral position. Engine braking has no effect in either of these conditions and the risk of an accident is consequently increased.
- Do not engage the clutch (i.e., release the clutch pedal) suddenly when starting the vehicle. By doing so the vehicle might unexpectedly accelerate or the transmission could malfunction.

CAUTION

Shift into reverse **ONLY** when the vehicle has completely stopped. It may cause damage to the transmission to try shifting into reverse when the vehicle is moving.

■ Shifting speeds

▼ Recommended shifting speeds

The best compromise between fuel economy and vehicle performance during normal driving is ensured by shifting up at the speeds listed in the following table.

Shift up	mph (km/h)
1st to 2nd	15 (24)
2nd to 3rd	25 (40)
3rd to 4th	40 (64)
4th to 5th	45 (72)

▼ Maximum allowable speeds

The following table shows the maximum speeds that are possible with each different gear. The tachometer's needle will enter the red area if these speeds are exceeded.

With the exception of cases where sudden acceleration is required, the vehicle should not be driven with the tachometer's needle inside the red area. Failure to observe this precaution can lead to excessive engine wear and poor fuel economy.

Gear	mph (km/h)
1st	28 (46)
2nd	53 (85)
3rd	77 (124)
4th	Legal speed limit (Posted limit speed)
5th	



WARNING

When shifting down a gear, ensure that the vehicle is not travelling at a speed exceeding the Maximum Allowable Speed for the gear which is about to be selected. Failure to observe this precaution can lead to engine over-revving and this in turn can result in engine damage.

In addition, sudden application of engine brakes when the vehicle is travelling on a slippery surface can lead to wheel locking; as a consequence, control of the vehicle may be lost and the risk of an accident increased.

NOTE

Never exceed the posted speed limit.

■ Driving tips



CAUTION

If the accelerator and brake pedals are depressed at the same time, driving torque may be restrained. This is not a malfunction.

Do not drive with your foot resting on the clutch pedal and do not use the clutch to hold your vehicle at a standstill on an upgrade. Either of those actions may cause clutch damage.

Do not drive with your hand resting on the shift lever. This may cause wear on the transmission components.

When it is necessary to reduce vehicle speed due to slow traffic, turning corners, or driving up steep hills, downshift to a lower gear before the engine starts to labor.

On steep downgrades, downshift the transmission to 4th, 3rd or 2nd gear as necessary; this helps to maintain a safe speed and to extend brake pad life.

In this way, the engine provides a braking effect. Remember, if you "ride" (over use) the brakes while descending a hill, they may overheat and not work properly.

The engine may, on rare occasions, knock when the vehicle rapidly accelerates or rapidly pulls away from a standstill. This phenomenon is not an indication of a problem in your vehicle.

Continuously variable transmission

WARNING

Do not shift from the “P” or “N” position into the “D” or “R” position while depressing the accelerator pedal. This may cause the vehicle to jump forward or backward.

CAUTION

- Shift into the “P” or “R” position only after the vehicle is completely stopped. Shifting while the vehicle is moving may cause damage to the transmission.
- Do not race the engine for more than 5 seconds in any position except the “N” or “P” position when the brake is applied or when chocks are used in the wheels. This may cause the transmission fluid to overheat.
- Never move the vehicle rearward by inertia with the select lever set in a forward driving position or move the vehicle forward by inertia with the select lever set

in the “R” position. Doing so may result in an unexpected accident or malfunction.

- Do not shift from the “D” position into the “R” position or vice versa until the vehicle has completely stopped. Such shifting may cause damage to the transmission.
- When parking the vehicle, first securely apply the parking brake and then place the select lever in the “P” position. Do not park for a long time with the select lever in any other position as doing so could result in a dead battery.

■ Continuously variable transmission features

The continuously variable transmission is electronically controlled and provides an infinite number of forward speeds and 1 reverse speed. For some models, it also has a manual mode or an “L” position.

NOTE

- When the engine coolant temperature is still low, the transmission will upshift or downshift at higher engine speeds than when the coolant temperature is sufficiently high in order to

shorten the warm-up time and improve driveability. The gearshift timing will automatically shift to the normal timing after the engine has warmed up.

- Immediately after transmission fluid is replaced, you may feel that the transmission operation is somewhat unusual. This results from invalidation of data which the on-board computer has collected and stored in memory to allow the transmission to shift at the most appropriate times for the current condition of your vehicle. Optimized shifting will be restored as the vehicle continues to be driven for a while.

- When driving a CVT model under continuous heavy load conditions such as when climbing a long, steep hill, the engine speed or the vehicle speed may automatically be reduced. This is not a malfunction. This phenomenon results from the engine control function maintaining the cooling performance of the vehicle. The engine and vehicle speed will return to a normal speed when the engine is able to maintain the optimum cooling performance after the heavy load decreases. Driving under a heavy load must be performed with extreme care. Do not try to pass a vehicle in front when driving on an uphill slope while under heavy load conditions.

- The continuously variable transmission is a chain type system that provides superior transmission efficiency for maximum fuel economy. At times, depending on varying driving conditions, a chain operating sound may be heard that is characteristic of this type of system.

■ Select lever

▼ Select lever positions

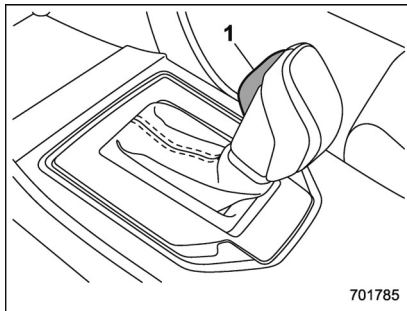

1) Select lever button

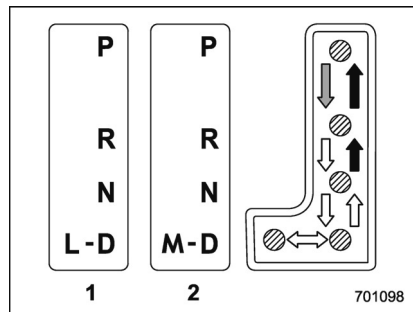

- Models with "L" position
- Models with manual mode

- ➡: With the brake pedal depressed, shift while pressing the select lever button in.
- ➡➡: Shift while pressing the select lever button in.
- ➡⬅: Shift without pressing the select lever button.

The select lever has four positions, "P", "R", "N", "D" and it also has an "L" or "M" gate.

NOTE

For some models, to protect the engine while the select lever is in the "P" or "N" position, the engine is controlled so that the engine speed may not become too high even if the accelerator

pedal is depressed hard.

▼ P (Park)

This position is for parking the vehicle and starting the engine. In this position, the transmission is mechanically locked to prevent the vehicle from rolling freely.

When you park the vehicle, first apply the parking brake firmly, then shift into the “P” position. Do not hold the vehicle with only the mechanical friction of the transmission.

To shift the select lever from the “P” position to any other position, you should depress the brake pedal fully then move the select lever. This prevents the vehicle from lurching when it is started.

▼ R (Reverse)

This position is for backing the vehicle. To shift from the “N” to “R” position, stop the vehicle completely then move the lever to the “R” position while pressing the select lever button in.

When the ignition switch has been turned to the “LOCK”/“OFF” position, movement of the select lever from the “N” to “R” position is possible for a limited time period by depressing the brake pedal, and then it becomes impossible. For details, refer to “Shift lock function” 7-28.

▼ N (Neutral)

This position is for restarting a stalled engine. In this position, the transmission is neutral, meaning that the wheels and transmission are not locked. Therefore, the vehicle will roll freely, even on the slightest incline unless the parking brake or foot brake is applied.

Avoid coasting with the transmission in neutral. Engine braking has no effect in this condition.



WARNING

Do not drive the vehicle with the select lever in the “N” (neutral) position. Engine braking has no effect in this condition and the risk of an accident is consequently increased.

NOTE

If the select lever is in the “N” position when you stop the engine for parking, you may not subsequently be able to move it to the “R” and “P” positions. If this happens, turn the ignition switch to the “ON” position. You will then be able to move the select lever to the “P” position.

▼ D (Drive)

This position is for normal driving. The transmission shifts automatically and continuously into a suitable gear according to the vehicle speed and the acceleration you require. Also, while driving up and down a hill, the transmission assists and controls the driving performance and engine braking while corresponding to the road grade.

When more acceleration is required in “D” position, depress the accelerator pedal fully to the floor and hold that position. The transmission will automatically downshift. In this case, the transmission will operate like a conventional automatic transmission. When you release the pedal, the transmission will return to the original gear position.

For models with manual mode, if one of the shift paddles behind the steering

wheel is operated while driving in the “D” position, the transmission will temporarily switch to the manual mode. In this mode, you can shift into any gear position using the shift paddles. For details about the manual mode, refer to “Selection of manual mode” ¶7-26. Once the vehicle speed stabilizes, the transmission will switch from the manual mode back to the “D” position for normal driving.

■ **Selection of manual mode (if equipped)**

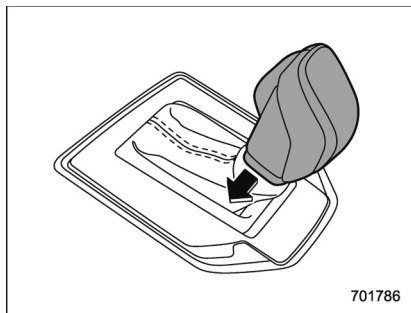

701786

With the vehicle either moving or stationary, move the select lever from the “D” position to the “M” position to select the manual mode.

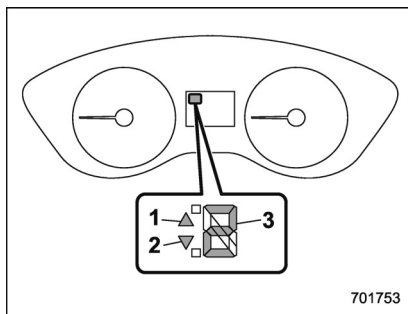

701753

Type A

- 1) Upshift indicator
- 2) Downshift indicator
- 3) Gear position indicator

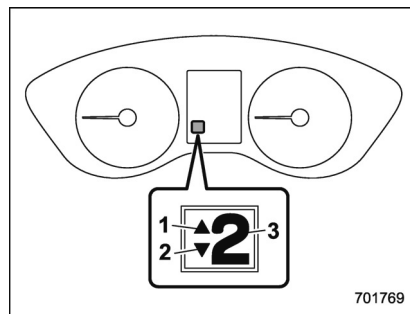

701769

Type B

- 1) Upshift indicator
- 2) Downshift indicator
- 3) Gear position indicator

When the manual mode is selected, the gear position indicator and upshift indicator and/or downshift indicator on the combination meter illuminate.

The gear position indicator shows the currently selected gear in the 1st-to-7th-gear range. The upshift and downshift indicators show when a gear shift is possible. When the upshift indicator “▲” illuminates, upshifting is possible. When the downshift indicator “▼” illuminates, downshifting is possible. When both indicators illuminate, upshifting and downshifting are both possible. When the vehicle stops (for example, at traffic

signals) the gear will be automatically shifted to the 1st position and the down-shift indicator will turn off.

Gearshifts can be performed using the shift paddle behind the steering wheel.

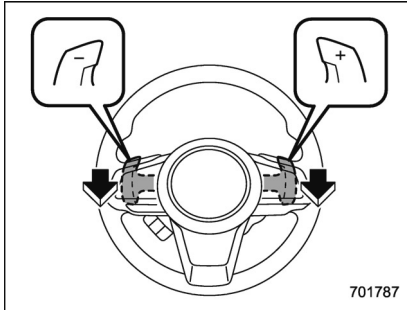

To upshift to the next higher gear position, pull the shift paddle that has "+" indicated on it. To downshift to the next lower gear position, pull the shift paddle that has "-" indicated on it.

To deselect the manual mode, return the select lever to the "D" position from the "M" position.

CAUTION

Do not place or hang anything on the shift paddles. Doing so may

result in accidental gear shifting.

NOTE

Please read the following points carefully and bear them in mind when using the manual mode.

- If you attempt to shift down when the engine speed is too high, i.e., when a downshift would push the tachometer needle beyond the red zone, beeps will be emitted to warn you that the downshift is not possible.
- If you attempt to shift up when the vehicle speed is too low, the transmission will not respond.
- You can perform a skip-shift (for example, from 4th to 2nd) by operating the shift paddle twice in rapid succession.
- The transmission automatically selects 1st gear when the vehicle stops moving.
- If the temperature of the transmission fluid becomes too high, the "AT OIL TEMP" warning light on the combination meter will illuminate. Immediately stop the vehicle in a safe location and let the engine idle until the warning light turns off.

■ Selection of "L" (if equipped)

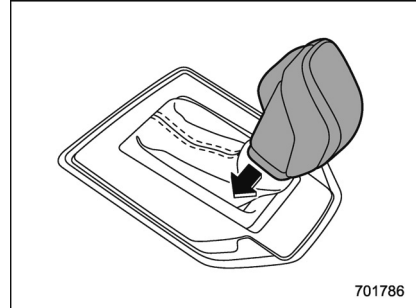

"L" is for using engine braking when going down a hill, etc. To select this mode, move the select lever from the "D" position to the "L" position.

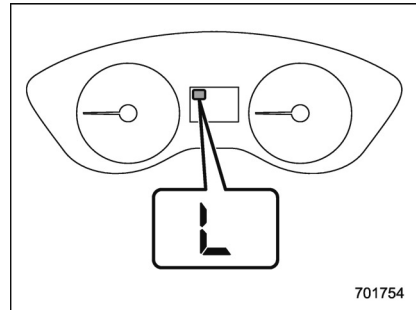

When selected, the indicator "L" will

illuminate on the combination meter.

To deselect "L", move the select lever to the "D" position.

■ Shift lock function

The shift lock function helps prevent the improper operation of the select lever.

- The select lever cannot be operated unless the ignition switch is turned to the "ON" position and the brake pedal is depressed.
- The select lever cannot be moved from the "P" position to any other position before the brake pedal is depressed. Depress the brake pedal first, and then operate the select lever.
- Only the "P" position allows you to turn the ignition switch from the "ACC" position to the "LOCK"/"OFF" position and remove the key from the ignition switch.
- If the ignition switch is turned to the "LOCK"/"OFF" position while the select lever is in the "N" position, the select lever may not be moved to the "P" position after a period of time. Therefore, move the select lever to the "P" position with the brake pedal depressed soon after the ignition switch is turned to the "LOCK"/"OFF" position.

▼ Shift lock release

If the select lever cannot be operated, turn the ignition switch back to the "ON" position then move the select lever to the "P" position with the select lever button pressed and brake pedal depressed.

If the select lever does not move after performing the above procedure, perform the following steps.

● When the select lever cannot be shifted from "P" to "N":

Refer to "Shift lock release using the shift lock release button" 7-28.

● When the select lever cannot be shifted from "N" to "R", "P":

Within 60 seconds after placing the ignition switch in the "ACC" position, move the select lever to the "P" position with the select lever button pressed and brake pedal depressed.

If you must perform the above procedure, the shift lock system (or the vehicle control system) may be malfunctioning. Contact a SUBARU dealer for an inspection as soon as possible.

If the select lever does not move after performing the above procedure, refer to "Shift lock release using the shift lock release button" 7-28.

▼ Shift lock release using the shift lock release button

Perform the following procedure to release the shift lock.

1. Apply the parking brake and turn the ignition switch to the "LOCK"/"OFF" position.

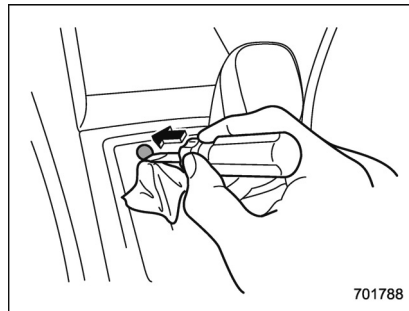

2. Wrap the tip of a flat-head screwdriver with vinyl tape or a cloth and use it to remove the shift lock cover. The shift lock release button is located under the shift lock cover.

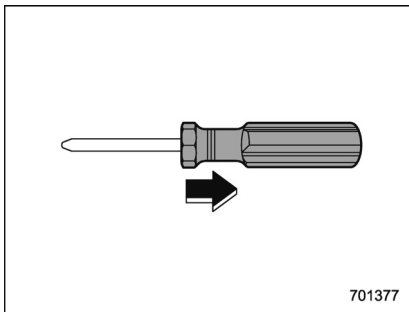

701377

3. Remove the grip portion of the screwdriver.

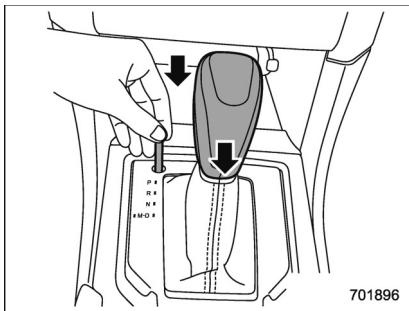

701896

4. While depressing the brake pedal, insert a screwdriver into the hole, move it right and left while pushing the shift lock release button using a screwdriver, and

then move the select lever.

If the select lever does not move after performing the above procedure, the shift lock system may be malfunctioning. Contact a SUBARU dealer for an inspection as soon as possible.

■ Driving tips



If the accelerator and brake pedals are depressed at the same time, driving torque may be restrained. This is not a malfunction.

- Always apply the foot or parking brake when the vehicle is stopped in the "D" or "R" position.
- Always apply the parking brake when parking your vehicle. Do not hold the vehicle with only the mechanical friction of the transmission.
- Do not keep the vehicle in a stationary position on an uphill grade by using the "D" position. Use the brake instead.
- The engine may, on rare occasions, knock when the vehicle rapidly accelerates or rapidly pulls away from a standstill. This phenomenon does not indicate a malfunction.

Power steering

■ Power steering warning light

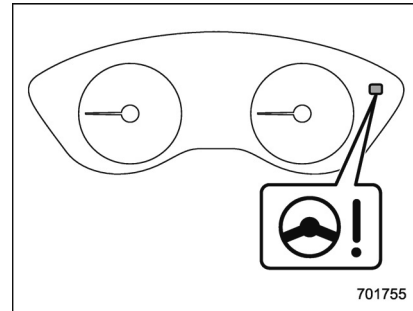

701755

■ Power steering system features

The vehicle is equipped with an electric power steering system. When the ignition switch is turned to the "ON" position, the power steering warning light on the combination meter illuminates to inform the driver that the warning system is functioning properly. Then, if the engine started, the warning light turns off to inform the driver that the steering power assist is operational.

CAUTION

When the power steering warning light is illuminated, there may be more resistance when the steering wheel is operated. Drive carefully to the nearest SUBARU dealer and have the vehicle inspected immediately.

NOTE

If the steering wheel is operated in the following ways, the power steering control system may temporarily limit the power assist in order to prevent the system components, such as the control computer and drive motor, from overheating.

- The steering wheel is operated frequently and turned sharply while the vehicle is maneuvered at extremely low speeds, such as while frequently turning the steering wheel during parallel parking.
- The steering wheel remains in the fully turned position for a long period of time.

At this time, there will be more resistance when steering. However this is not a malfunction. Normal steering force will be restored after the steering

wheel is not operated for a while and the power steering control system has an opportunity to cool down. However, if the power steering is operated in a non-standard way which causes power assist limitation to occur too frequently, this may result in a malfunction of the power steering control system.

Braking**Braking tips****WARNING**

Never rest your foot on the brake pedal while driving. This can cause dangerous overheating of the brakes and needless wear on the brake pads and linings.

▼ When the brakes get wet

When driving in rain or after washing the vehicle, the brakes may get wet. As a result, brake stopping distance will be longer. To dry the brakes, drive the vehicle at a safe speed while lightly depressing the brake pedal to heat up the brakes.

▼ Use of engine braking

Remember to make use of engine braking in addition to foot braking. When descending a grade, if only the foot brake is used, the brakes may start working improperly because of brake fluid overheating, caused by overheated brake pads. To help prevent this, shift into a lower gear to get stronger engine braking.

▼ Braking when a tire is punctured

Do not depress the brake pedal suddenly when a tire is punctured. This could cause

a loss of control of the vehicle. Keep driving straight ahead while gradually reducing speed. Then slowly pull off the road to a safe location.

■ Brake system

▼ Two separate circuits

Your vehicle has two separate circuit brake systems. Each circuit works diagonally across the vehicle. If one circuit of the brake system should fail, the other half of the system still works. If one circuit fails, the brake pedal will go down much closer to the floor than usual and you will need to press it down much harder. And a much longer distance will be needed to stop the vehicle.

▼ Brake booster

The brake booster uses engine manifold vacuum to assist braking force. Do not turn off the engine while driving because that will turn off the brake booster, resulting in poor braking power.

The brakes will continue to work even when the brake booster completely stops functioning. If this happens, you will have to depress the pedal much harder than during normal braking, and the braking distance will increase.

▼ Supplemental booster function when vacuum pressure fails

While the ignition switch is turned "ON" and the engine is running, the supplemental booster function operates when the brake booster performance is decreased due to insufficient vacuum boost. When the brake pedal is depressed while the supplemental booster function is operating, an operation sound and brake pedal vibration may be generated. This is not a malfunction.

▼ Brake assist system



WARNING

Do not be overconfident about the brake assist. It is not a system that brings more braking ability to the vehicle beyond its braking capability. Always use the utmost care when driving regarding vehicle speed and safe distance.



CAUTION

When you need to brake suddenly, continue depressing the brake pedal strongly to bring the effect of the brake assist.

Brake assist is a driver assistance system. It assists the brake power when the driver cannot depress the brake pedal strongly and the brake power is insufficient.

Brake assist generates the brake power according to the speed at which the driver depresses the brake pedal.

NOTE

When you depress the brake pedal strongly or suddenly, the following phenomena occur. However, even though these occur, they do not indicate any malfunctions, and the brake assist system is operating properly.

- You might feel that the brake pedal is applied by lighter force and generates a greater braking force.
- You might hear an ABS operating noise from the engine compartment.

■ Disc brake pad wear warning indicators

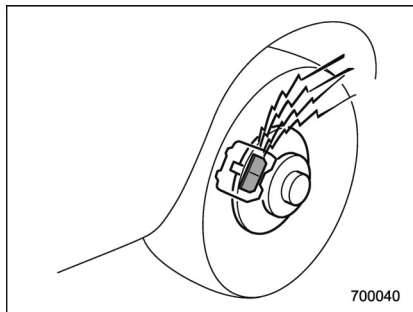

The disc brake pad wear warning indicators on the disc brakes give a warning noise when the brake pads are worn.

If a squeaking or scraping noise is heard from the disc brakes while braking, immediately have your vehicle checked by your SUBARU dealer.

ABS (Anti-lock Brake System)

The ABS prevents the lock-up of wheels which may occur during sudden braking or braking on slippery road surfaces. This helps prevent the loss of steering control and directional stability caused by wheel lock-up.

When the ABS is operating, you may hear a chattering noise or feel a slight vibration in the brake pedal. This is normal when the ABS operates.

The ABS will not operate when the vehicle speed is below approximately 6 mph (10 km/h).

WARNING

Always use the utmost care in driving – overconfidence because you are driving a vehicle with the ABS could easily lead to a serious accident.

CAUTION

- The ABS does not always decrease stopping distance. You should always maintain a safe

following distance from other vehicles.

- When driving on badly surfaced roads, gravel roads, icy roads, or over deep newly fallen snow, stopping distances may be longer for a vehicle with the ABS than one without. When driving under these conditions, therefore, reduce your speed and leave ample distance from other vehicles.
- When tire chains are installed, stopping distances may be longer for a vehicle with the ABS than one without. Be sure to reduce your speed and maintain a safe distance from the vehicle in front.
- When you feel the ABS operating, you should maintain constant brake pedal pressure. Do not pump the brake pedal since doing so may defeat the operation of the ABS.

■ ABS self-check

Just after the vehicle is started, you may feel on the brake pedal a vibration similar to when the ABS operates, and you may also hear the sound of the ABS working from the engine compartment. This is caused by an automatic functional test of the ABS being carried out and does not indicate a malfunction.

■ ABS warning light

Refer to “ABS warning light” 3-21.

Electronic Brake Force Distribution (EBD) system

The EBD system maximizes the effectiveness of the brakes by allowing the rear brakes to supply a greater proportion of the braking force. It functions by adjusting the distribution of braking force to the rear wheels in accordance with the vehicle's loading condition and speed.

The EBD system is an integral part of the ABS and uses some of the ABS components to perform its function of optimizing the distribution of braking force. If any of the ABS components used by the EBD system malfunction, the EBD system also stops working.

When the EBD system is operating, you may hear a chattering noise or feel a slight vibration in the brake pedal. This is normal and does not indicate a malfunction.

■ Steps to take if EBD system malfunctions

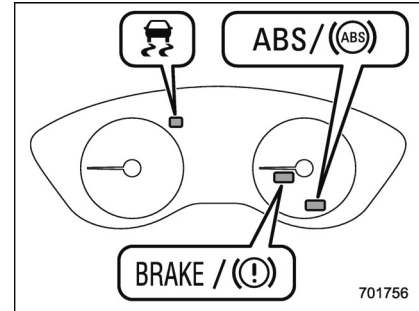

If a malfunction occurs in the EBD system, the system stops working and the following warning lights illuminate simultaneously.

- Brake system warning light
- ABS warning light
- Vehicle Dynamics Control warning light

The EBD system may be malfunctioning if all the warning lights illuminate simultaneously during driving.

Even if the EBD system malfunctions, the conventional braking system will still function. However, the rear wheels will be more prone to locking when the brakes are applied harder than usual and the vehicle's motion may therefore become

somewhat harder to control.

If all the warning lights illuminate simultaneously, take the following steps.

1. Stop the vehicle in the nearest safe, flat location.
2. Apply the parking brake and turn off the engine.
3. Restart the engine.
4. Release the parking brake.

If all the warning lights do not come back on:

The EBD system have a possible malfunction. Drive carefully to the nearest SUBARU dealer and have the system inspected.

If all the warning lights stay illuminated or come back on after approximately 2 seconds:

1. Turn off the engine again.
 2. Apply the parking brake.
 3. Check the brake fluid level. For details about checking the brake fluid level, refer to "Checking the fluid level" 11-15.
- If the brake fluid level is not below the "MIN" mark, the EBD system may be malfunctioning. Drive carefully to the nearest SUBARU dealer and have the system inspected.
 - If the brake fluid level is below the

"MIN" mark, DO NOT drive the vehicle. Instead, have the vehicle towed to the nearest SUBARU dealer for repair.

 **WARNING**

- **Driving with the brake system warning light illuminated is dangerous. This indicates your brake system may not be working properly. If the light remains illuminated, have the brakes inspected by a SUBARU dealer immediately.**
- **If at all in doubt about whether the brakes are operating properly, do not drive the vehicle. Have your vehicle towed to the nearest SUBARU dealer for repair.**

Vehicle Dynamics Control system

■ Safety precautions

 **WARNING**

Always use the utmost care in driving – overconfidence because you are driving a vehicle with the Vehicle Dynamics Control system could easily lead to a serious accident.

 **CAUTION**

- **Even if your vehicle is equipped with Vehicle Dynamics Control system, winter tires should be used when driving on snow-covered or icy roads; in addition, vehicle speed should be reduced considerably. Simply having a Vehicle Dynamics Control system does not guarantee that the vehicle will be able to avoid accidents in any situation.**
- **Activation of the Vehicle Dynamics Control system is an indication that the road being travelled on has a slippery sur-**

face; since having Vehicle Dynamics Control is no guarantee that full vehicle control will be maintained at all times and under all conditions, its activation should be seen as a sign that the speed of the vehicle should be reduced considerably.

- Whenever suspension components, steering components, or an axle are removed from a vehicle, have an inspection of that system performed by an authorized SUBARU dealer.
- The following precautions should be observed in order to ensure that the Vehicle Dynamics Control system is operating properly:
 - All four wheels should be fitted with tires of the same size, type, and brand. Furthermore, the amount of wear should be the same for all four tires.
 - Keep the tire pressure at the proper level as shown on the vehicle placard attached to the driver's side door pillar.
 - Use only the specified temporary spare tire to replace a flat tire. With a temporary

spare tire, the effectiveness of the Vehicle Dynamics Control system is reduced and this should be taken into account when driving the vehicle in such a condition.

- If non-matching tires are used, the Vehicle Dynamics Control system may not operate correctly.
- The Vehicle Dynamics Control system helps prevent unstable vehicle motion such as skidding using control of the brakes and engine power. Do not turn off the Vehicle Dynamics Control system unless it is absolutely necessary. If you must turn off the Vehicle Dynamics Control system, drive very carefully according to the road surface conditions.

■ System features

In the event of wheelspin and/or skidding on a slippery road surface and/or during cornering and/or an evasive maneuver, the Vehicle Dynamics Control system adjusts the engine's output and the wheels' respective braking forces to help

maintain traction and directional control.

● Traction Control Function

The traction control function is designed to prevent spinning of the driving wheels on slippery road surfaces, thereby helping to maintain traction and directional control. Activation of this function is shown by flashing the Vehicle Dynamics Control operation indicator light.

● Skid Suppression Function

The skid suppression function is designed to help maintain directional stability by suppressing the wheels' tendency to slide sideways during steering operations. Activation of this function is shown by flashing the Vehicle Dynamics Control operation indicator light.

NOTE

- The Vehicle Dynamics Control system may be considered normal when the following conditions occur.
 - Slight twitching of the brake pedal is felt.
 - The vehicle or steering wheel shakes to a small degree.
 - An operating sound from the engine compartment is heard briefly when starting the engine and when driving off after starting the engine.

- The brake pedal seems to jolt when driving off after starting the engine.
- In the circumstances shown in the following list, the vehicle may be less stable than it feels to the driver. The Vehicle Dynamics Control System may therefore operate. Such operation does not indicate a system malfunction.
 - on gravel-covered or rutted roads
 - on unfinished roads
 - when the vehicle is fitted with snow tires or winter tires
- Activation of the Vehicle Dynamics Control system will cause operation of the steering wheel to feel slightly different compared to that for normal conditions.
- It is always important to reduce speed when approaching a corner, even if your vehicle is equipped with the Vehicle Dynamics Control system.
- Always turn off the engine before replacing a tire. Failure to do so may render the Vehicle Dynamics Control system unable to operate correctly.

■ Vehicle Dynamics Control system monitor

Refer to “Vehicle Dynamics Control warning light/Vehicle Dynamics Control operation indicator light” ¶3-24 and “Vehicle Dynamics Control OFF indicator light” ¶3-25.

■ Vehicle Dynamics Control OFF switch

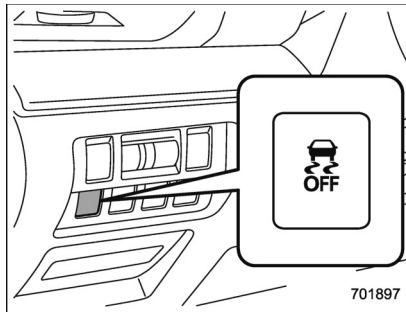

Press the Vehicle Dynamics Control OFF switch to deactivate the Vehicle Dynamics Control system. Creating adequate driving wheel slip by deactivating the Vehicle Dynamics Control system may help to recover from the loss of traction. Use the Vehicle Dynamics Control OFF switch as necessary.

- a standing start on a steeply sloping road with a snowy, gravel-covered, or otherwise slippery surface
- extrication of the vehicle when its wheels are stuck in mud or deep snow

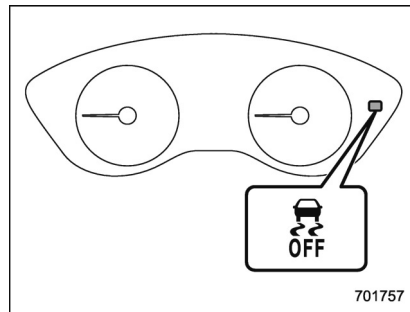

When the switch is pressed during engine operation, the Vehicle Dynamics Control OFF indicator light “OFF” on the combination meter illuminates. The Vehicle Dynamics Control system will be deactivated and the vehicle will behave like a model not equipped with the Vehicle Dynamics Control system. When the switch is pressed again to reactivate the Vehicle Dynamics Control system, the Vehicle Dynamics Control OFF indicator light turns off.

With the Vehicle Dynamics Control system deactivated, traction and stability en-

hancement offered by Vehicle Dynamics Control system is unavailable. Therefore you should not deactivate the Vehicle Dynamics Control system except under above-mentioned situations.

NOTE

- When the switch has been pressed to deactivate the Vehicle Dynamics Control system, the Vehicle Dynamics Control system automatically reactivates itself the next time the ignition switch is turned to the “LOCK”/“OFF” position and the engine is restarted.
- If the switch is held down for 30 seconds or longer, the indicator light turns off, the Vehicle Dynamics Control system is activated, and the system ignores any further pressing of the switch. To make the switch usable again, turn the ignition switch to the “LOCK”/“OFF” position and restart the engine.
- When the switch is pressed to deactivate the Vehicle Dynamics Control system, the vehicle’s running performance is comparable with that of a vehicle that does not have a Vehicle Dynamics Control system. Do not deactivate the Vehicle Dynamics Control system except when absolutely necessary.

- Even when the Vehicle Dynamics Control system is deactivated, components of the brake control system may still activate. When the brake control system is activated, the Vehicle Dynamics Control operation indicator light flashes.

Tire pressure monitoring system (TPMS) (U.S.-spec. models)

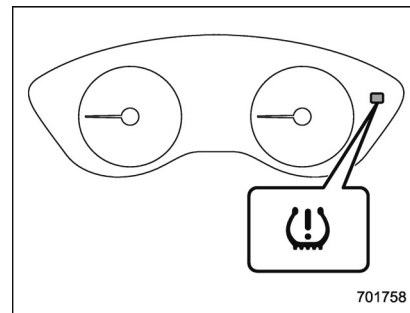

The tire pressure monitoring system provides the driver with a warning message when tire pressure is severely low.

The tire pressure monitoring system will activate only when the vehicle is driven at speeds above 20 mph (32 km/h). Also, this system may not react immediately to a sudden drop in tire pressure (for example, a blow-out caused by running over a sharp object).



WARNING

- If the low tire pressure warning light illuminates while driving,

never brake suddenly. Instead, perform the following procedure. Otherwise, an accident involving serious vehicle damage and serious personal injury could occur.

- (1) Keep driving straight ahead while gradually reducing speed.
- (2) Slowly pull off the road to a safe location.
- (3) Check the pressure for all four tires and adjust the pressure to the COLD tire pressure shown on the tire placard. The tire placard is located on the door pillar on the driver's side.

Even when the vehicle is driven a very short distance, the tires get warm and their pressures increase accordingly. Be sure to let the tires cool thoroughly before adjusting their pressures to the standard values shown on the tire placard. Refer to "Tires and wheels" 11-21. The tire pressure monitoring system does not function when the vehicle is stationary. After adjusting the tire pressures, increase the vehicle speed to at least 20 mph

(32 km/h) to start the TPMS rechecking of the tire inflation pressures. If the tire pressures are now above the severe low pressure threshold, the low tire pressure warning light should turn off a few minutes later.

If this light still illuminates while driving after adjusting the tire pressure, a tire may have significant damage and a fast leak that causes the tire to lose air rapidly. If you have a flat tire, replace it with a spare tire as soon as possible.

- When a spare tire is mounted or a wheel rim is replaced without the original pressure sensor/transmitter being transferred, the low tire pressure warning light will illuminate steadily after blinking for approximately one minute. This indicates the TPMS is unable to monitor all four road wheels. Contact your SUBARU dealer as soon as possible for tire and sensor replacement and/or system resetting.
- When a tire is repaired with liquid sealant, the tire pressure warning valve and transmitter may not operate properly. If a liquid sea-

lant is used, contact your nearest SUBARU dealer or other qualified service shop as soon as possible. Make sure to replace the tire pressure warning valve and transmitter when replacing the tire. You may reuse the wheel if there is no damage to it and if the sealant residue is properly cleaned off. Do not inject any tire liquid or aerosol tire sealant into the tires, as this may cause a malfunction of the tire pressure sensors. If the light illuminates steadily after blinking for approximately one minute, promptly contact a SUBARU dealer to have the system inspected.



CAUTION

Do not place metal film or any metal parts in the trunk. This may cause poor reception of the signals from the tire pressure sensors, and the tire pressure monitoring system will not function properly.

FCC ID: CWT1G049

NOTE

This device complies with part 15 of the FCC Rules. Operation is subject to the following two conditions: (1) This device may not cause harmful interference, and (2) this device must accept any interference received, including interference that may cause undesired operation.

FCC CAUTION

Changes or modifications not expressly approved by the party responsible for compliance could void the user's authority to operate the equipment.

Parking your vehicle**■ Parking brake**

To set the parking brake, depress the brake pedal firmly and hold it down until the parking brake lever is fully pulled up.

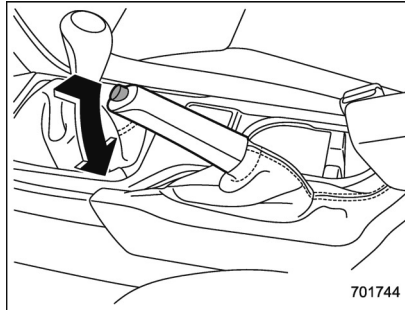

701744

To release the parking brake, pull the lever up slightly, press the release button, then lower the lever while keeping the button pressed.

When the parking brake is set while the engine is running, the parking brake warning light illuminates. After starting the vehicle, be sure that the warning light has turned off before the vehicle is driven. Refer to "Brake system warning light (red)" 3-21.

⚠ CAUTION

Never drive while the parking brake is set because this will cause unnecessary wear on the brake linings. Before starting to drive, always make sure that the parking brake has been fully released.

■ Parking tips

When parking your vehicle, always perform the following items.

- Apply the parking brake firmly.
- For MT models, put the shift lever in the "1" (1st) for upgrade or "R" (Reverse) for a downgrade.
- For CVT models, put the select lever in the "P" (Park) position.

Never rely on the mechanical friction of the transmission alone to hold the vehicle.

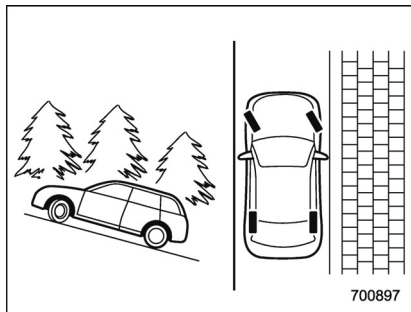

When parking on a hill, always turn the steering wheel. When the vehicle is headed up the hill, the front wheels should be turned away from the curb.

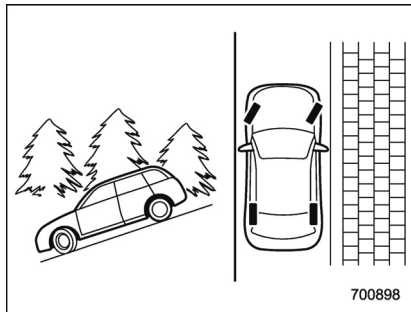

When facing downhill, the front wheels should be turned into the curb.

WARNING

- Never leave unattended children or pets in the vehicle. They could accidentally injure themselves or others through inadvertent operation of the vehicle. Also, on hot or sunny days, the temperature in a closed vehicle could quickly become high enough to cause severe or possibly fatal injuries to people.
- Do not park the vehicle over flammable materials such as dry grass, waste paper or rags, as they may burn easily if they come near hot engine or exhaust system parts.
- Be sure to stop the engine if you take a nap in the vehicle. If engine exhaust gas enters the passenger compartment, occupants in the vehicle could die from carbon monoxide (CO) contained in the exhaust gas.

CAUTION

If your vehicle has a front under spoiler (optional), pay attention to blocks and other obstructions on

the ground when parking. The under spoiler could be damaged by contact with them.

Hill start assist system

WARNING

- The Hill start assist system is a device only for helping the driver to **START** the vehicle on an uphill grade. To prevent accidents when the vehicle is parked on a slope, be sure to firmly set the parking brake. When setting the parking brake, make sure that the vehicle remains stationary when the clutch pedal (MT models) and brake pedal (both MT and CVT models) are released.
- Do not turn the ignition switch to the “LOCK”/“OFF” position while the Hill start assist system is operating. The Hill start assist system will be deactivated and may lead to an accident.

The Hill start assist system is a device to make the following vehicle operations easier.

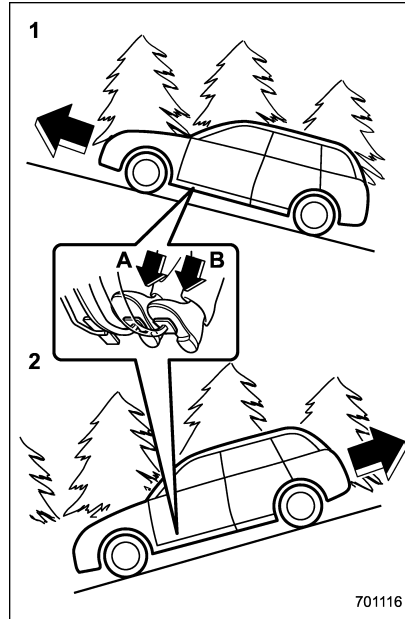

- 1) Starting forward facing uphill
 - 2) Starting backward facing downhill
- A) Brake pedal (both MT models and CVT models)
B) Clutch pedal (MT models only)

In both these cases, the Hill start assist system operates under the following con-

ditions.

- when the clutch pedal is depressed while the brake pedal is also depressed (MT models)
- when the vehicle has stopped with the brake pedal depressed (CVT models)

Braking power is maintained temporarily (for approximately 2 seconds) by the Hill start assist system after the brake pedal is released. The driver is therefore able to start the vehicle in the same way as on a level grade, just using the clutch pedal (MT models only) and accelerator pedal (all models).

If the braking power of the Hill start assist system is insufficient after the brake pedal is released, apply more braking power by depressing the brake pedal again.

The Hill start assist system may not operate on slight grades. Also, the Hill start assist system does not operate in the following cases.

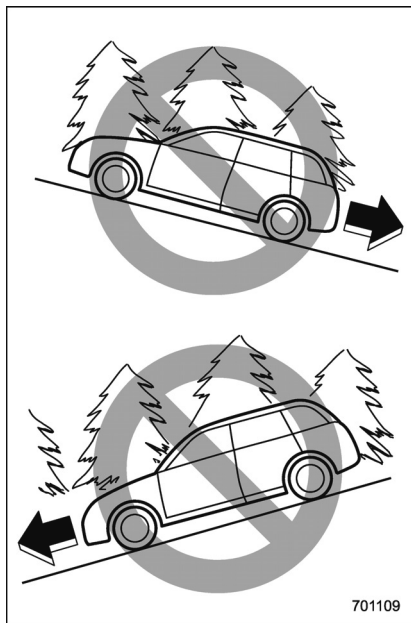

701109

- when starting backward facing uphill
- when starting forward facing downhill
- while the parking brake is applied
- while the ignition switch is in the “ACC” or “LOCK”/“OFF” position
- while the Hill start assist warning light/

Hill start assist OFF indicator light is illuminated. Refer to “Hill start assist warning light/Hill start assist OFF indicator light” 3-23.

When using the Hill start assist system, a braking effect may be felt even after the brake pedal has been released. However, for MT models, this braking effect should disappear once the clutch pedal is released.

NOTE

A slight jolt may be felt when the vehicle begins to move forward after being reversed.

■ To activate/deactivate the Hill start assist system

⚠ CAUTION

While the Hill start assist system is deactivated, when starting on an uphill grade, braking power is not maintained if the brake pedal is released. Start on an uphill grade by using the parking brake.

You can activate/deactivate the Hill start assist system according to the following procedure.

NOTE

If you make an error when performing any steps in the following procedure, place the ignition switch in the “LOCK”/“OFF” position once and then start over again.

▼ To deactivate

1. Park your vehicle in a flat and safe location and apply the parking brake.
2. Turn the ignition switch to the “LOCK”/“OFF” position.
3. Restart the engine.

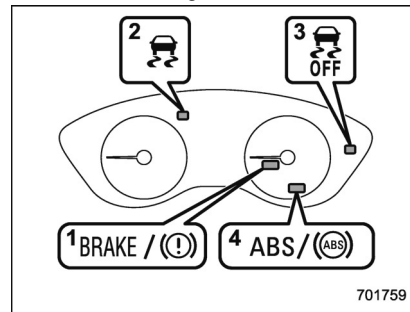

701759

4. Confirm the following items.
 - (1) The brake system warning light illuminates.
 - (2) The Vehicle Dynamics Control warning light turns off.

- (3) The Vehicle Dynamics Control OFF indicator light turns off.
- (4) The ABS warning light turns off.

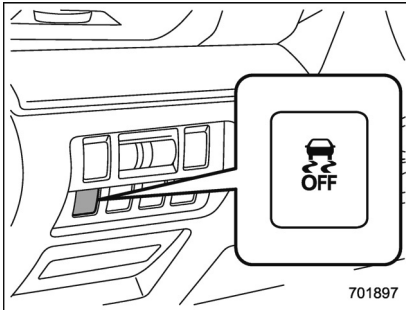

5. Press the Vehicle Dynamics Control OFF switch and hold it until the Vehicle Dynamics Control OFF indicator light "OFF" on the combination meter illuminates for 30 seconds and then turns off.
6. Within 5 seconds after the Vehicle Dynamics Control OFF indicator light turns off, release the Vehicle Dynamics Control OFF switch.

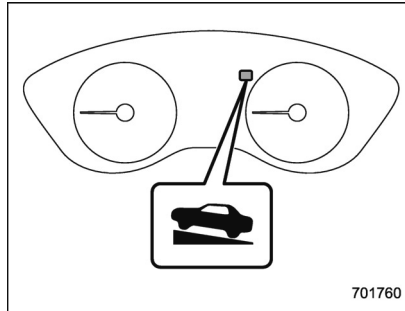

Hill start assist OFF indicator

7. Within 2 seconds after releasing the Vehicle Dynamics Control OFF switch, press the Vehicle Dynamics Control OFF switch once again. Then the Hill start assist OFF indicator light illuminates and turns off.
8. Turn the ignition switch to the "LOCK"/"OFF" position. The hill start assist system has now been deactivated.

NOTE

While the Hill start assist system is deactivated, the Hill start assist OFF indicator light illuminates.

▼ To activate

When the procedure to deactivate the Hill start assist system is performed again, the system is activated. When the Hill start assist system is activated, the Hill start assist OFF indicator light turns off.

■ Hill start assist warning light/Hill start assist OFF indicator light

Refer to "Hill start assist warning light/Hill start assist OFF indicator light" 3-23.

Cruise control (if equipped)

NOTE

For models with EyeSight system: Refer to the Owner's Manual supplement for the EyeSight system.

Cruise control enables you to maintain a constant vehicle speed without holding your foot on the accelerator pedal and it is operative when the vehicle speed is 20 mph (30 km/h) or more.

WARNING

Do not use the cruise control under any of the following conditions. These may cause loss of vehicle control.

- driving up or down a steep grade
- driving on slippery or winding roads
- driving in heavy traffic

NOTE

Make sure the cruise control system is turned off when the cruise control is not in use to avoid unintentionally setting of the cruise control.

To set cruise control

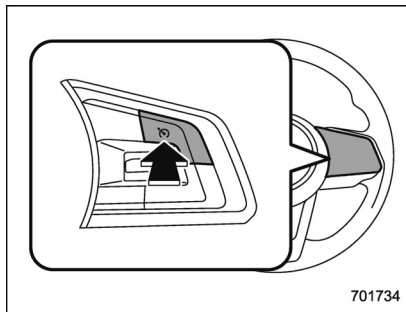

Cruise control main button

1. Press the cruise control main button.

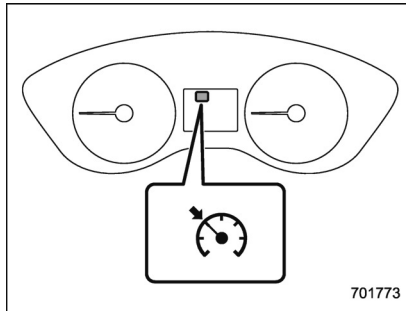

Cruise control indicator light (type A)

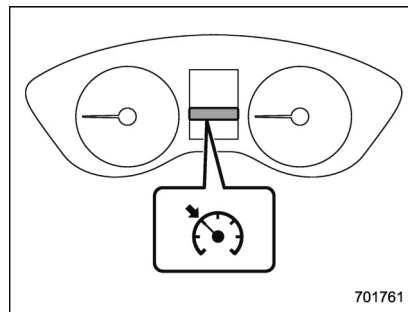

Cruise control indicator light (type B)

- The cruise control indicator light on the combination meter will illuminate.
2. Depress the accelerator pedal until the vehicle reaches the desired speed.

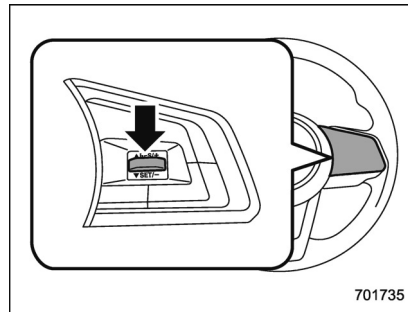

3. Press the "RES/SET" switch to the

“SET” side and release it. Then release the accelerator pedal.

NOTE

If the set vehicle speed has not been memorized (other than when it has been temporarily canceled), the vehicle speed can be set even if the “RES/SET” switch is pressed to the “RES” side.

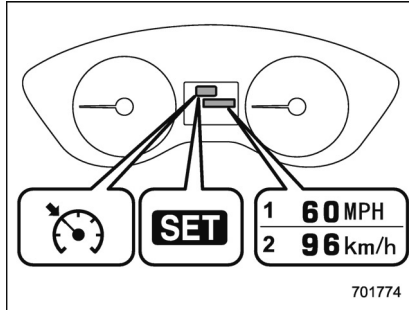

Cruise control set indicator light (type A)

- 1) When setting the displayed unit as “MPH”.
- 2) When setting the displayed unit as “km/h”.

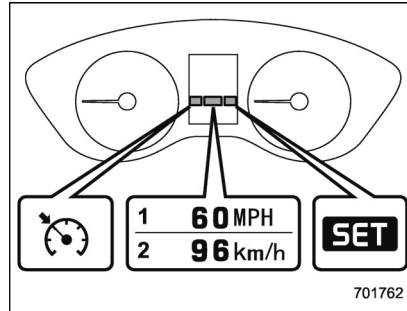

Cruise control set indicator light (type B)

- 1) When setting the displayed unit as “MPH”.
- 2) When setting the displayed unit as “km/h”.

At this time, the cruise control set indicator light is illuminated in the combination meter. The set speed will be shown on the combination meter. You can change the displayed unit by operating the combination meter display.

- For type A meter details, refer to “Combination meter settings” 3-11.
- For type B meter details, refer to “Screen Settings” 3-42.

The vehicle will maintain the desired speed.

Vehicle speed can be temporarily in-

creased while driving with the cruise control activated. Simply depress the accelerator pedal to accelerate the vehicle. When the accelerator pedal is released, the vehicle will return to and maintain the previous cruising speed.

■ To temporarily cancel the cruise control

The cruise control can be temporarily canceled in the following ways.

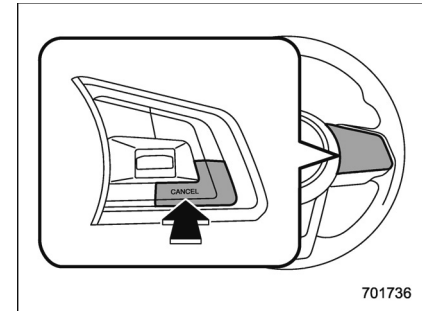

- Press the “CANCEL” button.
- Depress the brake pedal.
- Depress the clutch pedal (MT models only).

⚠ WARNING

For CVT models, you can cancel the cruise control by shifting the select lever into the “N” position. However, do not shift the lever into the “N” position while driving except in case of emergency. If the select lever is shifted into the “N” position, the engine brake will no longer work. This could result in an accident.

The cruise control set indicator light in the combination meter turns off when the cruise control is canceled.

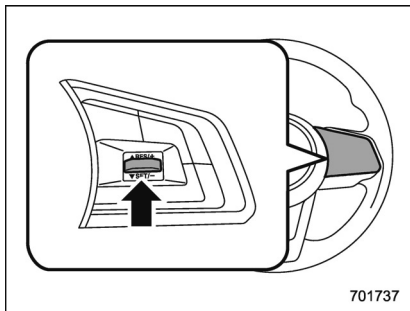

To resume the cruise control after it has been temporarily canceled and with vehicle speed of approximately 20 mph (30 km/h) or more, press the “RES/SET”

switch to the “RES” side to return to the original cruising speed automatically. The cruise control set indicator light in the combination meter will automatically illuminate at this time.

■ To turn off the cruise control

There are two ways to turn off the cruise control:

- Press the cruise control main button again.
- Turn the ignition switch to the “ACC” or “LOCK”/“OFF” position (but only when the vehicle is completely stopped).

■ To change the cruising speed

- ▼ To increase the speed (by the “RES/SET” switch)

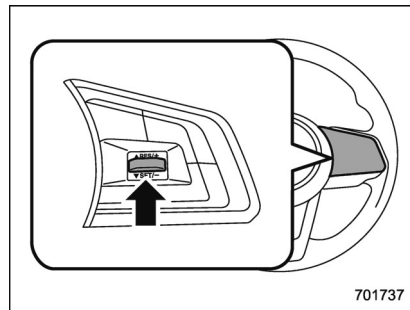

Press the “RES/SET” switch to the “RES” side and hold it until the vehicle reaches the desired speed. Then, release the switch. The vehicle speed at that moment will be memorized and treated as the new set speed.

When setting the displayed unit as “MPH”:

The set speed can be increased 1 mph (1.6 km/h) each time by pressing the “RES/SET” switch to the “RES” side.

When setting the displayed unit as "km/h":

The set speed can be increased 1 km/h each time by pressing the "RES/SET" switch to the "RES" side.

▼ To increase the speed (by accelerator pedal)

1. Depress the accelerator pedal to accelerate the vehicle to the desired speed.

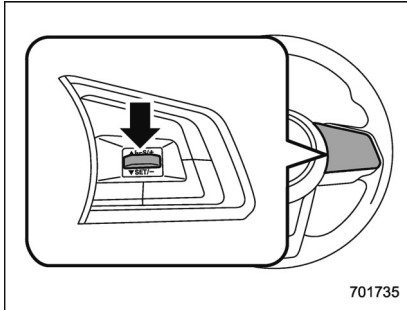

2. Press the "RES/SET" switch to the "SET" side once. Now the desired speed is set and the vehicle will keep running at that speed without depressing the accelerator pedal.

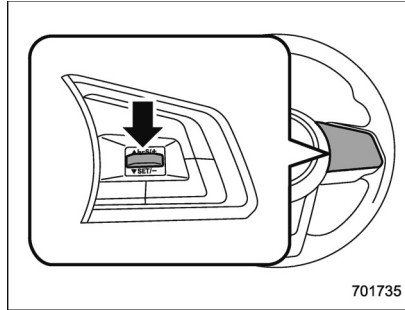
▼ To decrease the speed (by the "RES/SET" switch)

Press the "RES/SET" switch to the "SET" side and hold it until the vehicle reaches the desired speed. Then, release the switch. The vehicle speed at that moment will be memorized and treated as the new set speed.

When setting the displayed unit as "MPH":

The set speed can be decreased 1 mph (1.6 km/h) each time by pressing the "RES/SET" switch to the "SET" side.

When setting the displayed unit as "km/h":

The set speed can be decreased 1 km/h each time by pressing the "RES/SET" switch to the "SET" side.

BSD/RCTA (if equipped)

The BSD/RCTA consists of rear radar with Blind Spot Detection and Rear Cross Traffic Alert.

These functions enable the system to detect objects or vehicles to the rear, drawing attention to the driver when changing a lane or when driving in reverse.



WARNING

The driver is responsible for driving safely. Always be sure to check the surroundings with your eyes when changing lanes or reversing the vehicle.

The system is designed to assist the driver by monitoring the rear and side areas of the vehicle during a lane change or reversing. However, you cannot rely on this system alone in assuring the safety during a lane change or reversing. Overconfidence in this system could result in an accident and lead to serious injury or death. Since the system operation has various limitations, the flashing or illumination of the BSD/RCTA approach indicator

light may be delayed or it may not operate at all even when a vehicle is present in a neighboring lane or approaching from either side.

The driver is responsible for paying attention to the rear and side areas of the vehicle.

System features

BSD/RCTA consists of the following functions.

- To detect a vehicle in a blind spot on an adjacent lane or a vehicle approaching at high speed while driving the vehicle (Blind Spot Detection)
- To detect a vehicle approaching from the right or left while reversing the vehicle (Rear Cross Traffic Alert)

The system uses radar sensors for the above functions.

NOTE

The BSD/RCTA radar sensor has been certified by the radio wave related laws of the U.S. and Canada. When driving in other countries, certification of the country where the vehicle is driven must be obtained. For certification in the U.S. and Canada, refer to “Certification for the BSD/RCTA” 7-55.

▼ Blind Spot Detection (BSD)

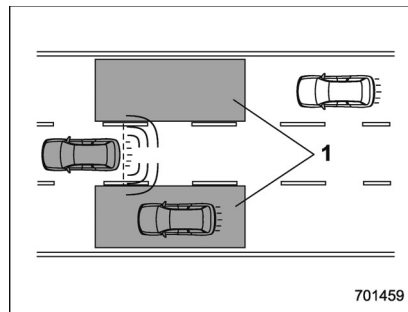

- 1) Operating range

The system notifies the driver of the presence of vehicles in its blind spot.

If the system detects a vehicle in its blind spot, it warns the driver by illuminating the BSD/RCTA approach indicator light(s) on the outside mirror(s).

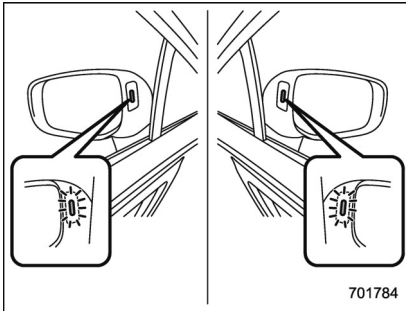

BSD/RCTA approach indicator light

If the driver operates the turn signal lever in the direction where the BSD/RCTA approach indicator light is illuminating, the system warns the driver of dangers by flashing the BSD/RCTA approach indicator light.

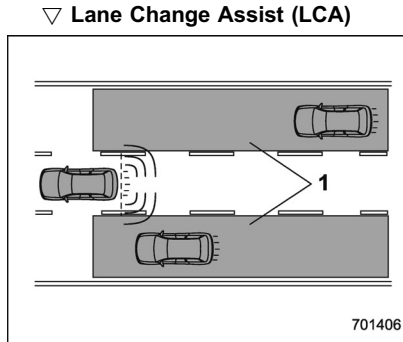

1) Operating range

The system notifies the driver of vehicles approaching at a high speed in the neighboring lanes.

- If the system detects vehicles approaching at a high speed in the neighboring lanes, it warns the driver of dangers by illuminating the BSD/RCTA approach indicator light(s) on the outside mirror(s).
- If the driver operates the turn signal lever in the direction where the BSD/RCTA approach indicator light is illuminating, the system warns the driver of dangers by flashing the BSD/RCTA approach indicator light.

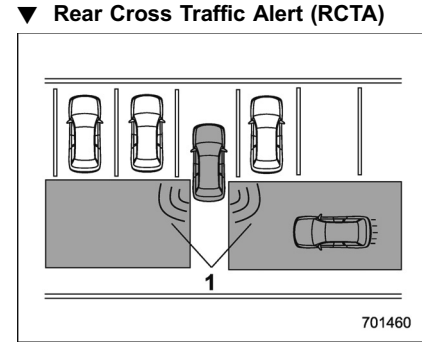

1) Operating range

The system notifies the driver of another vehicle approaching from either side when driving in reverse. This feature helps the driver check the rear and side areas of the vehicle when moving backward.

If the system detects a vehicle approaching from either side while moving backward, it warns the driver of dangers in the following way.

- The BSD/RCTA approach indicator light(s) on the outside mirror(s) flashes.
- A warning buzzer sounds.
- An icon appears on the rear view camera screen (audio/navigation monitor)

▽ Limitations of the detectability of RCTA

Since the detectability of RCTA is limited, the RCTA may not operate properly in parking spaces in which the parking spaces are drawn diagonally to the driving lanes.

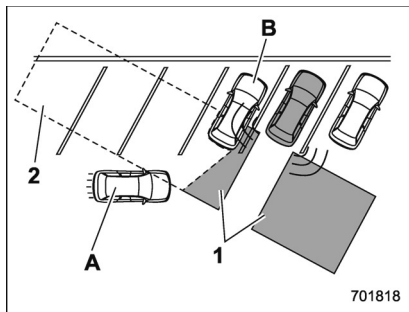

Example 1

- 1) The detection range of the radar sensors
 - 2) Area out of detection range of the radar sensors
- A) Vehicle that may not be detected
B) Parked vehicle



WARNING

An approaching vehicle (A) may not be detected because the detection range is limited by the parked

vehicle (B). Always be sure to check the surroundings with your eyes when reversing the vehicle.

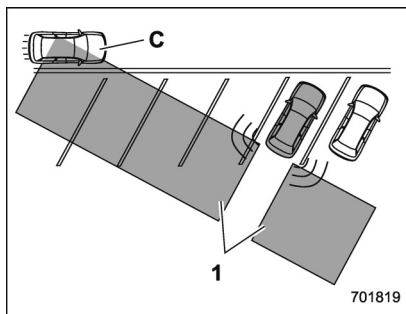

Example 2

- 1) The detection range of the radar sensors
- C) Vehicle that may be detected

NOTE

The system may detect that a vehicle (C) is passing in front of your vehicle. Always be sure to check the surroundings with your eyes when reversing the vehicle.

■ System operation

▽ Operating conditions

The BSD/RCTA will operate when all of the following conditions are met.

- The ignition switch is in the “ON” position.
- The BSD/RCTA warning indicator and BSD/RCTA OFF indicator are turned off.
- The vehicle is driven at speeds above 6 mph (10 km/h) (except when reversing).
- The shift lever/select lever is in the “R” position (when reversing).

The BSD/RCTA will not operate in the following situations.

- The BSD/RCTA OFF indicator is on.
- The vehicle speed is below 6 mph (10 km/h) even when the BSD/RCTA OFF indicator remains off (except when reversing).

NOTE

• In the following case, the BSD/RCTA will stop operating and the BSD/RCTA warning indicator will appear. If the BSD/RCTA warning indicator appears, have your vehicle inspected at a SUBARU dealer as soon as possible.

- When a malfunction occurs in the system, including the BSD/RCTA approach indicator light

- In the following cases, the BSD/RCTA will temporarily stop operating (or may stop operating) and the BSD/RCTA warning indicator will appear.

- When the radar sensor becomes significantly misaligned (If the orientation of the radar sensor is shifted for any reason, readjustment is required. Have the sensor adjusted at a SUBARU dealer.)
- When a large amount of snow or ice sticks to the rear bumper surface around the radar sensors
- When the vehicle is driven on a snow-covered road or in an environment in which there are no objects around (such as in a desert) for a long time
- When the temperature around the radar sensors increased excessively due to long driving on uphill grades in summer, etc.
- When the temperature around the radar sensors becomes extremely low
- When the vehicle battery voltage lowers
- When the vehicle battery becomes overvoltage

When the above conditions are corrected, the BSD/RCTA will resume

operation and the BSD/RCTA warning indicator will disappear. However, if the BSD/RCTA warning indicator has appeared for a prolonged time, have the system inspected at a SUBARU dealer as soon as possible.

- The detectability of the radar sensors is restricted. The BSD/RCTA detection may be impaired and the system may not operate properly under the following conditions.

- When the rear bumper around the radar sensors is distorted
- When ice, snow or mud adheres to the rear bumper surface around the radar sensors
- When stickers, etc. are affixed on the areas of the radar sensors on the rear bumper
- During adverse weather conditions such as rain, snow or fog
- When driving on wet roads such as snow-covered roads and through puddles
- The radar sensors may not detect or may have difficulty detecting the following.
 - Small motorcycles, bicycles, pedestrians, stationary objects on the road or road side, etc.
 - Vehicles with body shapes that the radar may not reflect (vehicles

with a low body height such as sports cars or a trailer with no cargo)

- Vehicles that are not approaching your vehicle even though they are in the detection area (either on a neighboring lane to the rear or beside your vehicle when reversing) (The system determines the presence of approaching vehicles based on data detected by the radar sensors.)

- Vehicles traveling at significantly different speeds
- Vehicles driving in parallel at almost the same speed as your vehicle for a prolonged time
- Oncoming vehicles
- Vehicles in a lane beyond the neighboring lane
- Vehicles travelling at a significantly lower speed that you are trying to overtake

- On a road with extremely narrow lanes, the system may detect vehicles driving in a lane next to the neighboring lane.

- When the 8-inch audio/navigation system is performing a software update, the RCTA warning icons may not be displayed on the audio/navigation screen until the update is complete.

■ BSD/RCTA approach indicator light/warning buzzer

When the BSD/RCTA is active, the BSD/RCTA approach indicator light will operate to alert the driver when there are vehicles in the neighboring lanes. When reversing the vehicle, the BSD/RCTA approach indicator light and warning buzzer will operate to alert the driver that a vehicle is approaching from the left or right side.

▼ BSD/RCTA approach indicator light

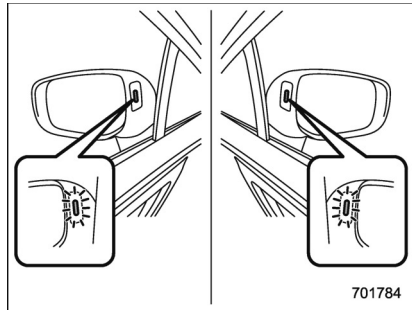

BSD/RCTA approach indicator light

It is mounted in each side of the outside mirrors and will illuminate when a vehicle approaching from behind is detected. If an indicator light is illuminated and the turn signal lever is operated toward the side in which this light turned on, the indicator

light flashes to warn the driver of dangers. When reversing the vehicle, the indicator light flashes when the system detects a vehicle approaching from either side.

▼ BSD/RCTA approach indicator light dimming function

When the headlights are turned on, the brightness of the BSD/RCTA approach indicator light will be reduced.

NOTE

- When affected by direct sunlight, you may have difficulty recognizing the BSD/RCTA approach indicator light.
- When affected by the headlight beams from the vehicles behind, you may have difficulty recognizing the BSD/RCTA approach indicator light.
- While the illumination brightness control dial is in the fully upward position, even if the headlights are turned on, the brightness of the BSD/RCTA approach indicator light will not be reduced. For details about the illumination brightness control dial, refer to “Illumination brightness control” 3-12.

▼ BSD/RCTA approach warning buzzer (only when reversing)

A warning buzzer sounds along with flashing of the BSD/RCTA approach indicator light to warn the driver of dangers.

The setting of the warning buzzer volume can be changed by operating the combination meter display (color LCD). For details, refer to “Menu screens” 3-39.

▼ Safety tips regarding the BSD/RCTA approach indicator light/warning buzzer

- In the following cases, operation of the BSD/RCTA approach indicator light and the warning buzzer may be delayed or the system may fail to issue these warnings.
 - When a vehicle moves to the neighboring lane from a lane next to the neighboring lane
 - When driving on a steep incline or on repeated sharp uphill and downhill grades
 - When going beyond a pass
 - When both your vehicle and a vehicle driving on a neighboring lane are driving on the far side of each lane.
 - When several narrowly-spaced vehicles are approaching in a row
 - In low radius bends (tight bends or when making turns at an intersection)

- When there is a difference in height between your lane and the neighboring lane
- Immediately after the BSD/RCTA is activated by pressing the BSD/RCTA OFF switch
- Immediately after the shift lever/select lever is shifted to the “R” position
- When extremely heavy cargo is loaded in the trunk or cargo area
- During reversing, operation of the BSD/RCTA approach indicator light and the warning buzzer may be delayed or the system may fail to issue these warnings under the following conditions.
 - When backing out of an angled parking space
 - When a large-sized vehicle is parked next to your vehicle (That vehicle prevents the propagation of radar waves.)
 - When reversing on sloped roads
 - When reversing at a high speed

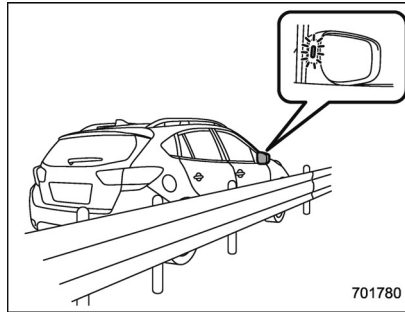

- The BSD/RCTA approach indicator light may illuminate when driving close to solid objects on the road or road side (such as guardrails, tunnels and side-walls).
- The BSD/RCTA approach indicator light may flash when turning at an intersection in urban areas or a multilane intersection.
- The BSD/RCTA approach indicator light may flash and the warning buzzer may sound if a building or a wall exists in the reversing direction.
- In the following cases, the system may detect a vehicle driving two lanes away from your vehicle.
 - When you are driving on the near side of its lane from the corresponding vehicle

- When the vehicle driving two lanes away is driving on the near side of its lane from your vehicle

■ BSD/RCTA warning indicator

▼ System temporary stop indicator

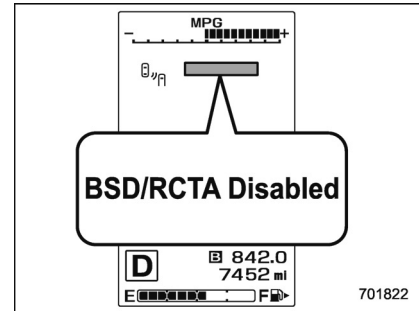

System temporary stop indicator

This indicator appears when the system is used under the following conditions.

- Extremely high or low temperatures
- When abnormal voltage exists for the vehicle battery
- When the radar sensor is significantly misaligned

Once the above conditions are corrected, the system will recover from the temporary stop condition and the indicator will

disappear. If the indicator remains displayed for a prolonged time, have the system inspected at a SUBARU dealer.

▼ **System temporary stop indicator due to reduced radar sensitivity**

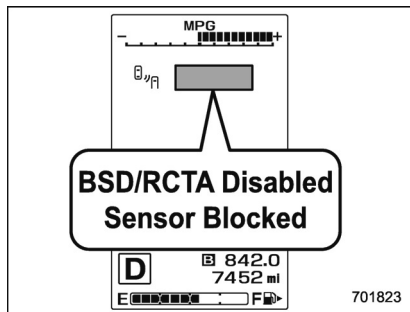

System temporary stop indicator due to reduced radar sensitivity

This indicator appears when the detectability of the radar sensors is reduced. Once the condition is corrected, the system will recover from the temporary stop condition and the indicator will disappear. If the indicator remains displayed for a prolonged time, have the system inspected at a SUBARU dealer.

▼ **System malfunction indicator**

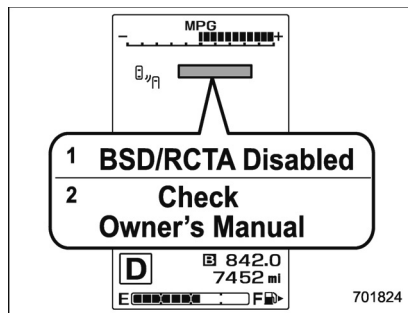

System malfunction indicator

- 1) At first, this message will appear
- 2) Then this message will appear

This indicator appears when a malfunction occurs in the system. Contact a SUBARU dealer and have the system inspected.

■ **BSD/RCTA OFF switch**

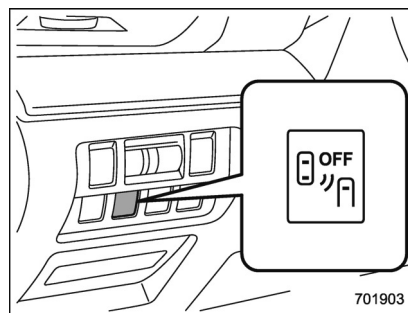

BSD/RCTA OFF switch

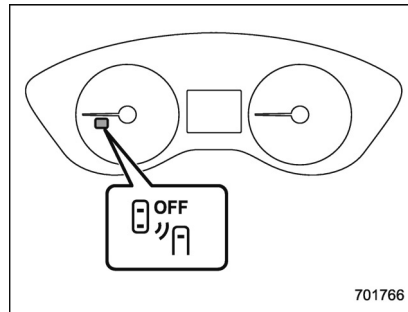

BSD/RCTA OFF indicator (type A)

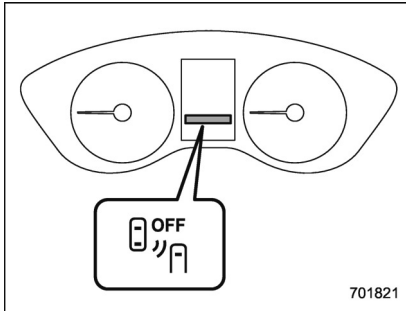

BSD/RCTA OFF indicator (type B)

If the BSD/RCTA OFF switch is pressed, the BSD/RCTA OFF indicator appears on the combination meter, and the BSD/RCTA is deactivated.

Press the switch again to activate the BSD/RCTA. The BSD/RCTA OFF indicator will disappear.

When this occurs, the BSD/RCTA approach indicator light on the side of the rearview mirror illuminates for a few seconds and then turns off.

NOTE

- In the following cases, the system may not operate properly due to blocked radar waves. Press the BSD/RCTA OFF switch to deactivate the system.

- When a bicycle carrier or other item is fitted to the rear of the vehicle
- When using a chassis dynamometer or free roller device, etc.
- When running the engine and making the wheels rotate while lifting up the vehicle

- If the ignition switch is turned to the “LOCK”/“OFF” position, the last known status of the system is maintained. For example, if the ignition switch is turned to the “LOCK”/“OFF” position with the BSD/RCTA deactivated, the BSD/RCTA will remain deactivated the next time the ignition switch is turned to the “ON” position.

- If the vehicle battery is disconnected due to situations such as battery terminal or fuse replacement, after the battery is reconnected, the BSD/RCTA will be activated.

■ Certification for the BSD/RCTA

- U.S.-spec. models

FCC ID: OAYSRR3A



CAUTION

FCC WARNING

Changes or modifications not expressly approved by the party responsible for compliance could void the user's authority to operate the equipment.

This device complies with part 15 of the FCC Rules. Operation is subject to the following two conditions: (1) This device may not cause harmful interference, and (2) this device must accept any interference received, including interference that may cause undesired operation.

- Canada-spec. models

NOTE

This device complies with Industry Canada's licence-exempt RSSs. Operation is subject to the following two conditions: (1) This device may not cause interference; and (2) This device must accept any interference, including interference that may cause undesired operation of the device.

REMARQUE

Le présent appareil est conforme aux CNR d'Industrie Canada applicables aux appareils radio exempts de licence. L'exploitation est autorisée aux deux conditions suivantes: (1) l'appareil ne doit pas produire de brouillage; (2) l'utilisateur de l'appareil doit accepter tout brouillage radioélectrique subi, même si le brouillage est susceptible d'en compromettre le fonctionnement.

■ Handling of radar sensors

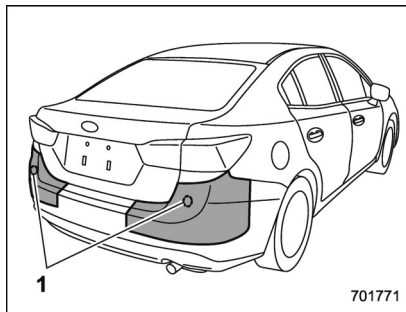

1) Radar sensors (sedan)

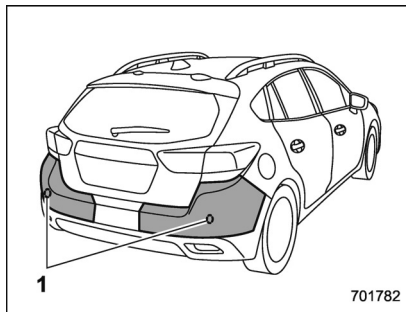

1) Radar sensors (5-door models)

The radar sensors, one on each side of the vehicle, are mounted inside the rear

bumper.

To ensure correct operation of the BSD/RCTA, observe the following precautions.

- Always keep the bumper surface near the radar sensors clean.
- Do not affix any stickers or other items on the bumper surface near the radar sensors.
- Do not modify the bumper near the radar sensors.
- Do not paint the bumper near the radar sensors.
- Do not expose the bumper near the radar sensors to strong impacts. If a sensor becomes misaligned, a system malfunction may occur, including the inability to detect vehicles entering the detection areas. If any strong shock is applied to the bumper, be sure to contact your SUBARU dealer for inspection.
- Do not disassemble the radar sensors.

NOTE

If the radar sensors require repair or replacement, or the bumper area around the radar sensors requires repair, paintwork or replacement, contact your SUBARU dealer for assistance.

Reverse Automatic Braking System (if equipped)

Reverse Automatic Braking is a system designed to help avoid collisions or reduce collision damage when reversing the vehicle. If a wall or an obstacle is detected in the reversing direction, the system will notify the driver with a warning sound and may activate the vehicle's brakes automatically.



WARNING

- Reverse Automatic Braking is not a system intended to replace the driver's responsibility to check surrounding areas for vehicles or obstacles to avoid a collision.
- The driver is responsible for driving safely. Always be sure to check the surroundings visually when reversing the vehicle.
- Since the system operation has various limitations, the warning sound or automatic braking may be delayed or may not operate at all even when an obstacle is present in the reversing direction.
- The system is not designed to

detect people (including children), animals or other moving objects.

- Depending on the vehicle condition or the surrounding environment, the sonar sensor's ability to detect objects may be compromised.

NOTE

The Reverse Automatic Braking System records and stores the following data when automatic braking operates. It does not record conversations, personal information or other audio data.

- Distance from the object
- Vehicle speed
- Accelerator pedal operation status
- Brake pedal operation status
- Select lever position
- Outside temperature
- The sensitivity setting of the sonar sensors

SUBARU and third parties contracted by SUBARU may acquire and use the recorded data for the purpose of vehicle research and development. SUBARU and third parties contracted by SUBARU will not disclose or provide the acquired data to any other

third party except under the following conditions.

- The vehicle owner has given his/her consent.
- The disclosure/provision is based on a court order or other legally enforceable request.
- Data that has been modified so that the user and vehicle cannot be identified is provided to a research institution for statistical processing or similar purposes.

■ Reverse Automatic Braking System overview

The system detects objects using sonar sensors installed in the rear bumper.

- If the system determines a possible collision with an object in the reversing direction, automatic deceleration will be activated. Also, beeping sounds will activate.
- If the vehicle is further reversed, automatic hard braking will be applied and a continuous beeping sound will activate.

▼ Detecting range

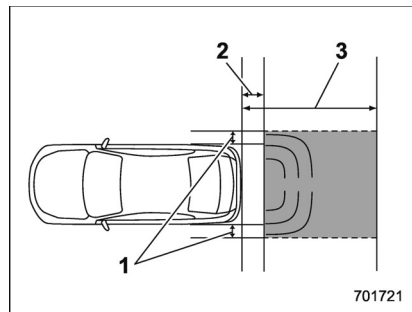

- 1) Detecting range (width): Approximately 6 in (15 cm) outside of the vehicle width
- 2) Range that the system cannot detect: Approximately 20 in (50 cm) behind the rear of the vehicle
- 3) Detecting range (length): Approximately 5 ft (1.5 m) from the rear of the vehicle

**WARNING**

If your vehicle is trapped on a railroad crossing and you are trying to escape by reversing through the crossing gate, the system may recognize the crossing gate as an obstacle and the brake may activate. In this case, remain calm and either continue to depress the accelerator pedal or cancel the system. To

cancel the system, refer to “Canceling the Reverse Automatic Braking system operation” 7-63.

■ Operating conditions

The Reverse Automatic Braking system will operate when all of the following conditions are met.

- The ignition switch is in the “ON” position
- The EyeSight warning indicator is off
- The Reverse Automatic Braking fail indicator is off
- HALT (Reverse Automatic Braking system OFF) indicator is off
- The Reverse Automatic Braking system is set to on
- The select lever is in the “R” position
- The vehicle speed is between 1 to 9 mph (1.5 to 15 km/h)

NOTE

- In the following cases, the Reverse Automatic braking system will not operate. Promptly contact a SUBARU dealer to have the system inspected.
 - The EyeSight warning indicator is illuminated
 - The Reverse Automatic Braking fail indicator is illuminated

- When the Reverse Automatic Braking system OFF indicator is illuminated, the Reverse Automatic braking system cannot be operated.

- In the following cases, the system may not be able to properly detect an obstacle. Promptly contact a SUBARU dealer to have the system inspected.

- A sticker, paint, or a chemical is applied to the rear bumper near the sonar sensor
- The rear bumper is modified
- The rear bumper has been removed and reattached
- The ground clearance is changed due to the vehicle’s loading condition or modification
- Ice, snow or mud is adhered to the rear bumper near the sonar sensor
- The rear bumper is exposed to strong impact, or the rear bumper is deformed

- When the 8-inch audio/navigation system is performing a software update, the Reverse Automatic Braking System may not display the following items on the audio/navigation screen until the update is complete.

- Display Icon on/off Function
- Distance Indicator Image
- Warning Message

- On a steep hill, the system's automatic braking ability will be reduced.
- The system is designed to avoid collisions by automatic hard braking when the vehicle's reversing speed is less than approximately 3 mph (5 km/h). However, the system does not guarantee that the vehicle will be able to avoid collisions in any situation.
- If the vehicle is reversed at an extremely slow speed, the driver's operation may be prioritized. In this case, automatic braking will not operate.
- The system may not be able to detect the following objects
 - Sharp or thin objects such as poles, fences and ropes which may not reflect the sound wave emitted from the sonar sensor
 - Objects that are too close to the rear bumper when the select lever is set to the "R" position
 - Objects with a surface which may not reflect the sound wave emitted from the sonar sensor such as a chain link fence.
- Objects the system is not designed to detect
 - Pedestrians
 - Moving objects including moving vehicles

- Objects which absorb sound waves such as cloth or snow
- Objects whose surface has a diagonal angle
- Objects that are low to the ground such as parking blocks
- Objects that are high above the ground such as objects hanging from above
- The system may not be able to properly detect objects or may cause a system malfunction when the following conditions exist

High frequency sound from other sources are nearby

- Horn sound from another vehicle
- Engine sound from other vehicles
- Sound of an air brake
- Vehicle detection equipment or a sonar from another vehicle
- A sound wave with a frequency similar to the vehicle's system is transmitted nearby
- A vehicle equipped with the same system is reversing toward your reversing direction

Weather conditions

- Extremely high or extremely low temperatures in which the area near

the sonar sensor becomes too hot or too cold to operate

- The rear bumper near the sonar sensors is exposed to heavy rain or a significant amount of water
- Fog, snow or sandstorm, etc.
- Air is moving rapidly such as when a strong wind is blowing

Parts attached to the rear bumper near the sonar sensor

- Commercial electronic parts (fog light, fender pole, radio antenna) or commercial attachment parts (trailer hitch, bicycle carrier, bumper guard) are attached
- Parts that emit high frequency sound, such as a horn or speaker, are attached

Vehicle conditions

- The vehicle is significantly inclined
- The ground clearance is significantly reduced due to the vehicle's loading condition, etc.
- When the sonar sensor is misaligned due to a collision or an accident

Surrounding environment

- A cloth banner, flag, hanging branch or railroad crossing bars are present in the reversing direction
- When reversing on a gravel or grassy area
- When reversing in an area where objects or walls are adjacent to the vehicle such as narrow tunnels, narrow bridges, narrow roads or narrow garages
- Wheel tracks or a hole is present in the ground of the reversing direction
- When reversing over a drainage cover (grate cover)

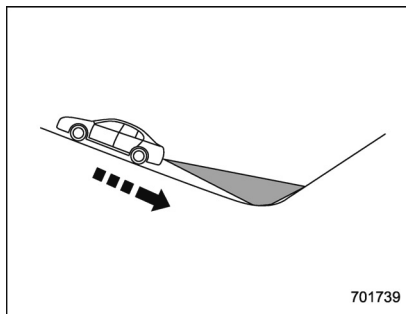

- The path of the reversing direction is inclined such as on a steep uphill
- A curb is present in the reversing direction
- When reversing downhill

Reverse Automatic Braking System operation

When the Reverse Automatic Braking System is in operation, the range between the vehicle and the detected object will be indicated on the audio/navigation monitor. Also, warning sounds will activate in 3 levels to warn the driver of a potential collision.

While the RAB is operating, a warning message is displayed on the audio/navigation monitor and the combination meter display (color LCD).

Guideline of detecting range

Alert level	Range of detected object*	Distance indicator	Alarm pattern
Long proximity (object detected)	35 inches (90 cm) or more	Green	No warning sound
Medium proximity alert (approaching the object)	28 to 35 inches (70 to 90 cm)	Yellow	Short beeps
Short proximity alert (approaching closer to the object)	20 to 28 inches (50 to 70 cm)	Orange	Rapid short beeps
Closest proximity alert (too close to the object)	20 inches (50 cm) or less	Red	Continuous beep

*: Range of detection may vary depending on the environmental condition.

▼ Obstacle detected and alert level

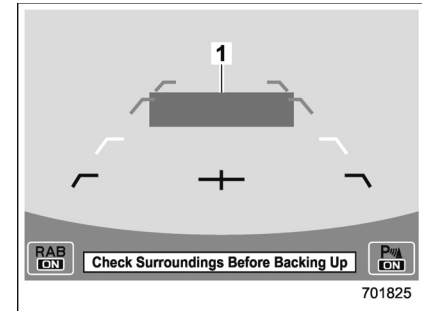
**Long proximity alert (object detected)**

- 1) Green: 35 inches (90 cm) or more

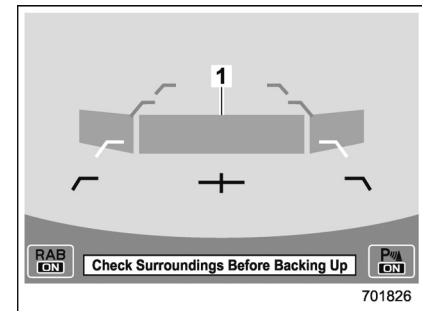
**Medium proximity alert (approaching the object)**

- 1) Yellow: 28 to 35 inches (70 to 90 cm)

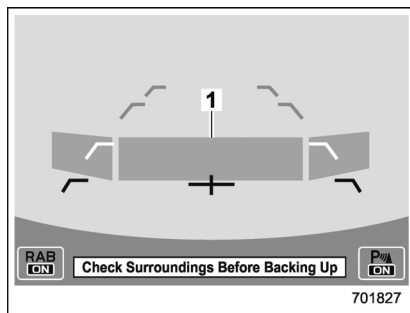

Short proximity alert (approaching the object closer)

1) Orange: 20 to 28 inches (50 to 70 cm)

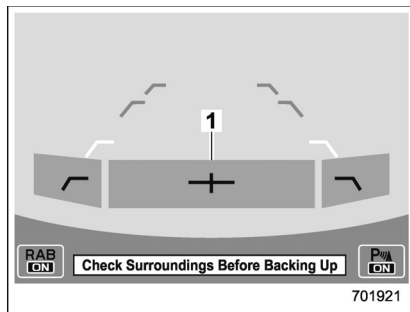

Closest proximity alert (too close to the object)

1) Red: 20 inches (50 cm) or less

When an object is detected in the reversing direction, the range of detected object will be shown on the audio/navigation monitor.

A warning alarm will sound and, depending on the speed, either torque control to generate engine braking or automatic braking will be applied.

▼ **Object close behind warning**

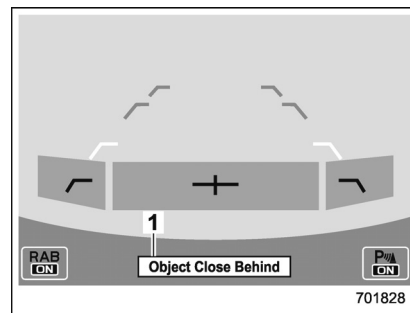

Automatic braking warning

1) Warning message

If the vehicle continues to go in reverse, the system may determine the risk of collision with the object. In this case, short warning beeps or continuous warning beeps will sound and either strong automatic braking or torque control will be applied to prevent collision.

▼ **When the vehicle is being stopped by the system**

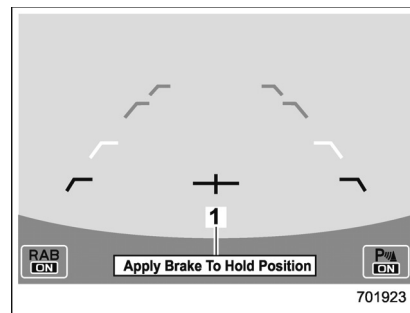

Depress brake pedal warning

1) Warning message

Make sure to depress the brake pedal once the vehicle has been stopped by automatic braking. Until the brake pedal is depressed, a message will be displayed on the audio/navigation monitor and the continuous beep will remain sounding.

At this time, a warning message is also displayed on the combination meter display (color LCD).

- ▼ After the vehicle is stopped by the system

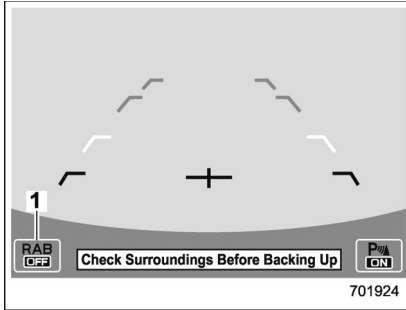

- 1) Reverse Automatic Braking system OFF indicator

After the brake pedal is depressed, the Reverse Automatic Braking system OFF indicator will illuminate and the system will temporarily stop operating. The Reverse Automatic Braking system OFF indicator will turn off when the select lever is shifted to a position other than the "R" position.

The system will operate again the next time the select lever is shifted to "R" position.

NOTE

Automatic braking only holds the vehicle for 2 seconds. Before the automatic brake is released, a warning

sound (3 short beeps followed by a long beep) will activate to alert the driver that the automatic will be released.

■ Canceling the Reverse Automatic Braking system operation

The Reverse Automatic Braking system can be temporarily canceled by any of the following operations.

- While the vehicle is stopped by the operation of automatic braking, the brake pedal is depressed
- While the vehicle is stopped by the operation of automatic braking, the accelerator pedal is depressed
- The accelerator pedal is depressed hard (In this case, limited acceleration will be canceled and the vehicle will continue reversing.)
- The select lever is shifted to a position other than the "R" position

NOTE

The system will be canceled if the object is no longer detected.

■ Reverse Automatic Braking system ON/OFF setting

While the select lever is shifted to the "R" position, the below functions of the Reverse Automatic Braking system can be set by operating the audio/navigation monitor.

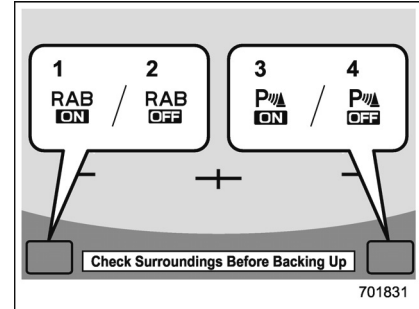

- 1) ON setting key of Reverse Automatic Braking
- 2) OFF setting key of Reverse Automatic Braking
- 3) ON setting key of the object detection warning beeping sound
- 4) OFF setting key of the object detection warning beeping sound

When the ON setting key is shown, the corresponding setting is ON.

Touch and hold the ON setting key to turn the setting OFF.

When the OFF setting is shown, the corresponding setting is OFF.

Touch and hold the OFF setting key to turn the setting ON.

When the Reverse Automatic Braking system is turned OFF, the following indicator will illuminate.

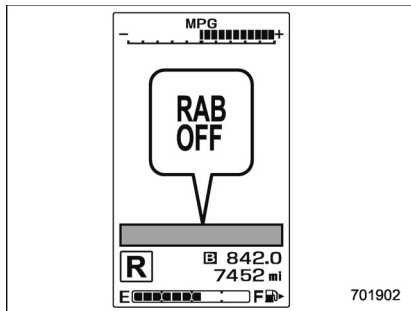

RAB OFF indicator: illuminates when the Reverse Automatic Braking system is turned OFF.

RAB OFF indicator will turn off when the Reverse Automatic Braking system is turned ON.

NOTE

- When the settings cannot be changed, the ON/OFF setting key will be grayed out.
- The ON/OFF setting key may be greyed out if the Reverse Automatic Braking system malfunctions, etc. In this case, turn the ignition switch to the "LOCK"/"OFF" position and then turn it to the "ON" position again. If the setting cannot be changed even after turning the ignition switch to the "ON" position again, consult your SUBARU dealer.
- The settings will be restored as follows when the select lever is shifted to the "R" position next time.
 - Reverse Automatic Braking system settings: default (ON setting)
 - Object detection warning beeping sound: the setting selected by operating the combination meter display (color LCD)

Also, the following settings can be changed by operating the combination meter display (color LCD).

- Warning volume
- Sonar audible alarm ON/OFF

For details, refer to "Menu screens" 3-39.

■ RAB warning indicator

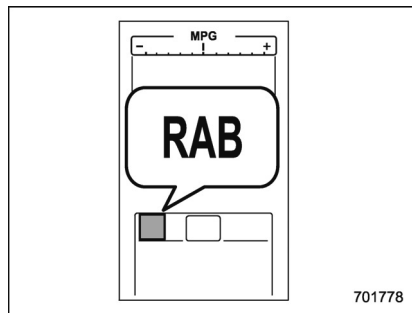

If the Reverse Automatic Braking System malfunctions, the above indicator illuminates on the combination meter. Contact the nearest SUBARU dealer for details.

■ Handling of the sonar sensors

The 4 sonar sensors are located in the rear bumper. To ensure the proper operation of the Reverse Automatic Braking system, observe the following precautions.

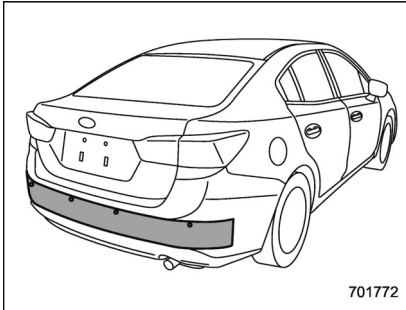

701772

Sedan

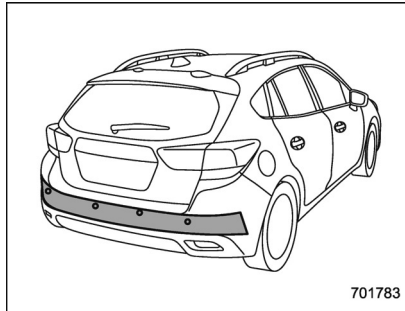

701783

5-door models

- Do not affix any stickers or other items on the bumper surface near the sonar sensors.
- Always keep the rear bumper surface near the sonar sensors clean.
- Do not modify the rear bumper.
- Do not paint the bumper near the sonar sensors.
- Do not apply strong impacts to the rear bumper near the sonar sensors. If a sensor becomes misaligned, a system malfunction may occur, including inability to detect objects in the reversing direction. If any strong impact is applied to the rear bumper, contact a SUBARU dealer to have the system inspected.
- Do not disassemble the sonar sensors.

NOTE

If the sonar sensors require repair or replacement, or if the area of the rear bumper near the sonar sensors requires repair, paintwork or replacement, contact your SUBARU dealer for assistance.

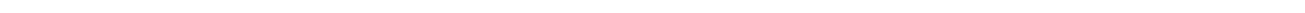
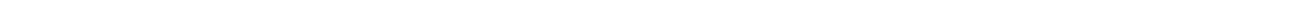
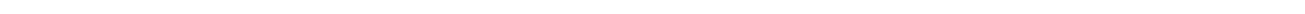
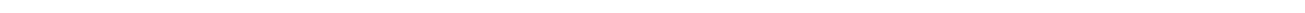
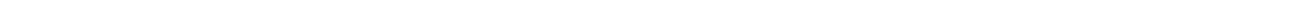
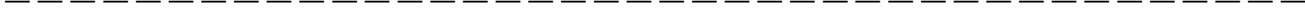
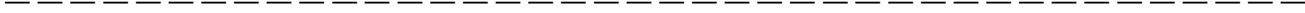
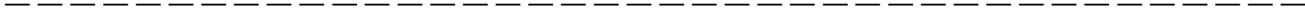
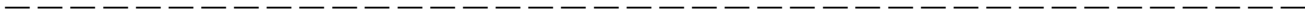
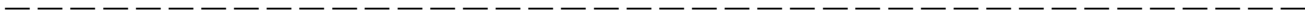
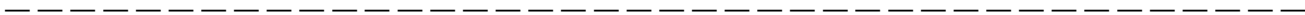

New vehicle break-in driving – the first 1,000 miles (1,600 km)	8-2	Corrosion protection	8-8
Fuel economy hints	8-2	Snow tires	8-8
Engine exhaust gas (carbon monoxide)	8-2	Tire chains	8-9
Catalytic converter	8-3	Rocking the vehicle	8-9
Periodic inspections	8-4	Loading your vehicle	8-10
Driving in foreign countries	8-4	Vehicle capacity weight	8-10
Driving tips for AWD models	8-4	GVWR and GAWR (Gross Vehicle Weight Rating and Gross Axle Weight Rating)	8-11
Winter driving	8-6	Roof rail (if equipped)	8-12
Operation during cold weather	8-6	Roof molding and crossbar (if equipped)	8-12
Driving on snowy and icy roads	8-7	Trailer towing	8-14

New vehicle break-in driving – the first 1,000 miles (1,600 km)

The performance and long life of your vehicle are dependent on how you handle and care for your vehicle while it is new. Follow these instructions during the first 1,000 miles (1,600 km):

- Do not race the engine. And do not allow engine speed to exceed 4,000 rpm except in an emergency.
- Do not drive at one constant engine or vehicle speed, either fast or slow.
- Avoid starting suddenly and rapid acceleration, except in an emergency.
- Avoid hard braking, except in an emergency.

The same break-in procedures should be applied to an overhauled engine, newly mounted engine or when brake pads or brake linings are replaced with new ones.

Fuel economy hints

The following suggestions will help to save fuel.

- Select the proper gear position for the speed and road conditions.
- Avoid sudden acceleration or deceleration. Always accelerate gently until you reach the desired speed. Then try to maintain that speed for as long as possible.
- Do not pump the accelerator and avoid racing the engine.
- Avoid unnecessary engine idling.
- Keep the engine properly tuned.
- Keep the tires inflated to the correct pressure shown on the tire placard, which is located under the door latch on the driver's side. Low pressure will increase tire wear and fuel consumption.
- Use the air conditioner only when necessary.
- Keep the front and rear wheels in proper alignment.
- Avoid carrying unnecessary luggage or cargo.

Engine exhaust gas (carbon monoxide)



WARNING

- **Never inhale engine exhaust gas. Engine exhaust gas contains carbon monoxide, a colorless and odorless gas which is dangerous, or even lethal, if inhaled.**
- **Always properly maintain the engine exhaust system to prevent engine exhaust gas from entering the vehicle.**
- **Never run the engine in a closed space, such as a garage, except for the brief time needed to drive the vehicle in or out of it.**
- **Avoid remaining in a parked vehicle for a lengthy time while the engine is running. If that is unavoidable, then use the ventilation fan to force fresh air into the vehicle.**
- **Always keep the front ventilator inlet grille free from snow, leaves or other obstructions to ensure that the ventilation system always works properly.**
- **If at any time you suspect that**

exhaust fumes are entering the vehicle, have the problem checked and corrected as soon as possible. If you must drive under these conditions, drive only with all windows fully open.

- Keep the trunk lid (sedan) or rear gate (5-door models) closed while driving to prevent exhaust gas from entering the vehicle.

NOTE

Due to the expansion and contraction of the metals used in the manufacture of the exhaust system, you may hear a crackling sound coming from the exhaust system for a short time after the engine has been shut off. This sound is normal.

Catalytic converter

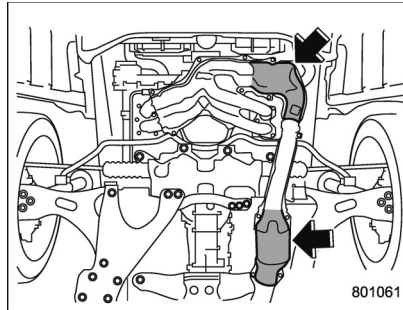

The catalytic converter is installed in the exhaust system. It serves as a catalyst to reduce HC, CO and NO_x in exhaust gases, thus providing cleaner exhaust.

To avoid damage to the catalytic converter:

- Use only unleaded fuel. Even a small amount of leaded fuel will damage the catalytic converter.
- Never start the engine by pushing or pulling the vehicle.
- Avoid racing the engine.
- Never turn the ignition switch to the "OFF" position while the vehicle is moving.
- Keep your engine tuned-up. If you feel the engine running rough (misfiring, back-

firing or incomplete combustion), have your vehicle checked and repaired by an authorized SUBARU dealer.

- Do not apply undercoating or rust prevention treatment to the heat shield of catalytic converter and the exhaust system.
- Do not drive with an extremely low fuel level.



WARNING

- **Avoid fire hazards. Do not drive or park the vehicle anywhere near flammable materials (e.g., grass, paper, rags or leaves), because the catalytic converter operates at very high temperatures.**
- **Keep everyone and flammable materials away from the exhaust pipe while the engine is running. The exhaust gas is very hot.**

Periodic inspections

To keep your vehicle in the best condition at all times, always have the recommended maintenance services listed in the maintenance schedule in the “Warranty and Maintenance Booklet” performed at the specified time or mileage intervals.

Driving in foreign countries

When planning to use your vehicle in another country:

- Confirm the availability of the correct fuel. Refer to “Fuel requirements” 7-3.
- Comply with all regulations and requirements of each country.

Driving tips for AWD models



WARNING

- **Always maintain a safe driving speed according to the road and weather conditions in order to avoid having an accident on a sharp turn, during sudden braking or under other similar conditions.**
- **Always use the utmost care in driving – overconfidence because you are driving an All-Wheel Drive vehicle could easily lead to a serious accident.**
- **When replacing or installing tire (s), all four tires must be the same for following items.**
 - (a) Size
 - (b) Circumference
 - (c) Speed symbol
 - (d) Load index
 - (e) Construction
 - (f) Manufacturer
 - (g) Brand (tread pattern)
 - (h) Degrees of wear

For the items (a) to (d), you must obey the specification that is

printed on the tire placard. The tire placard is located on the driver's door pillar.

If all of four tires are not the same for items (a) to (h), serious mechanical damage could occur to the drive train of your car, and affect the following.

- Ride
- Handling
- Braking
- Speedometer/Odometer calibration
- Clearance between the body and tires

It also may be dangerous and lead to loss of vehicle control, and it can lead to an accident.

CAUTION

If you use a temporary spare tire to replace a flat tire, be sure to use the original temporary spare tire stored in the vehicle. Using other sizes may result in severe mechanical damage to the drive train of your vehicle.

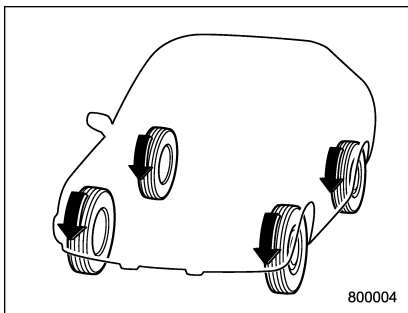

All-Wheel Drive distributes the engine power to all four wheels. AWD models provide better traction when driving on slippery, wet or snow-covered roads and when moving out of mud, dirt and sand. By shifting power between the front and rear wheels, SUBARU AWD can also provide added traction during acceleration and added engine braking force during deceleration.

Therefore, your SUBARU AWD vehicle may handle differently than an ordinary two wheel drive vehicle and it contains some features unique to AWD. For safety purposes as well as to avoid damaging the AWD system, you should keep the following tips in mind.

- An AWD model is better able to climb steeper roads under snowy or slippery

conditions than a two wheel drive vehicle. There is little difference in handling, however, during extremely sharp turns or sudden braking. Therefore, when driving down a slope or turning corners, be sure to reduce your speed and maintain an ample distance from other vehicles.

- Always check the cold tire pressure before starting to drive. The recommended tire pressure is provided on the tire placard, which is located under the door latch on the driver's side.
- Never attempt to drive through pools and puddles, or roads flooded with water. Water entering the engine air intake or the exhaust pipe or water splashing onto electrical parts may damage your vehicle and may cause it to stall.
- There are some precautions that you must observe when towing your vehicle. For detailed information, refer to "Towing" 9-14.

Winter driving

■ Operation during cold weather

▼ Maintenance

Carry some emergency equipment, such as a window scraper, a bag of sand, flares, a small shovel and jumper cables.

Check the battery and cables. Cold temperatures reduce battery capacity. The battery must be in good condition to provide enough power for cold winter starts.

It normally takes longer to start the engine in very cold weather conditions. Use an engine oil of a proper grade and viscosity for cold weather. Using heavy summer oil will make it harder to start the engine.

Keep the door locks from freezing by squirting them with deicer or glycerin.

Forcing a frozen door open may damage or separate the rubber weather strips around the door. If the door is frozen, use hot water to melt the ice, and afterwards thoroughly wipe the water away.

Use a windshield washer fluid that contains an antifreeze solution. Do not use engine antifreeze or other substitutes because they may damage the paint of

the vehicle.

SUBARU Windshield Washer Fluid contains 58.5% methyl alcohol and 41.5% surfactant, by volume. Its freezing temperature varies according to how much it is diluted, as indicated in the following table.

Washer Fluid Concentration	Freezing Temperature
30%	10.4°F (-12°C)
50%	-4°F (-20°C)
100%	-49°F (-45°C)

In order to prevent freezing of washer fluid, check the freezing temperatures in the table above when adjusting the fluid concentration to the outside temperature.

If you fill the reservoir tank with a fluid with a different concentration from the one used previously, purge the old fluid from the piping between the reservoir tank and washer nozzles by operating the washer for a certain period of time. Otherwise, if the concentration of the fluid remaining in the piping is too low for the outside temperature, it may freeze and block the nozzles.



CAUTION

- Adjust the washer fluid concentration appropriately for the outside temperature. If the concentration is inappropriate, sprayed washer fluid may freeze on the windshield and obstruct your view, and the fluid may freeze in the reservoir tank.
- State or local regulations on volatile organic compounds may restrict the use of methanol, a common windshield washer antifreeze additive. Washer fluids containing non-methanol antifreeze agents should be used only if they provide cold weather protection without damaging your vehicle's paint, wiper blades or washer system.

▼ Before driving your vehicle

Before entering the vehicle, remove any snow or ice from your shoes because that could make the pedals slippery and driving dangerous.

While warming up the vehicle before driving, check that the accelerator pedal, brake pedal, and all other controls operate smoothly.

Clear away ice and snow that has accumulated under the fenders to avoid making steering difficult. During severe winter driving, stop when and where it is safe to do so and check under the fenders periodically.

▼ Parking in cold weather

WARNING

Snow can trap dangerous exhaust gases under your vehicle. Keep snow clear of the exhaust pipe and from around your vehicle if you park the vehicle in snow with the engine running.

CAUTION

- Do not use the parking brake when parking for long periods in cold weather since it could freeze in that position.
- When the vehicle is parked in snow or when it snows, raise the wiper blades off the glass to prevent damage to them.
- When the vehicle has been left parked after use on roads heavily covered with snow, or has been left parked during a snowstorm,

icing may develop on the brake system, which could cause poor braking action. Check for snow or ice buildup on the suspension, disc brakes and brake hoses underneath the vehicle. If there is caked snow or ice, remove it, being careful not to damage the disc brakes and brake hoses and ABS harness.

When parking for long periods in cold weather, you should observe the following tips.

1. For MT models, place the shift lever in the “1” or “R” position. For CVT models, place the select lever in the “P” position.
2. Use tire stops under the tires to prevent the vehicle from moving.

▼ Refueling in cold weather

To help prevent moisture from forming in the fuel system and the risk of its freezing, use of an antifreeze additive in the fuel tank is recommended during cold weather. Use only additives that are specifically designed for this purpose. When an antifreeze additive is used, its effect lasts longer if the tank is refilled whenever the fuel level reaches half empty.

If your SUBARU is not going to be used

for an extended period, it is best to have the fuel tank filled to capacity.

■ Driving on snowy and icy roads

To prevent skidding and slipping, avoid sudden braking, abrupt acceleration, high-speed driving, and sharp turning when driving on snowy or icy roads.

Always maintain ample distance between your vehicle and the vehicle ahead of you to avoid the need for sudden braking.

To supplement the foot brake, use the engine brake effectively to control the vehicle speed. (Shift into a lower gear when necessary.)

Avoid shifting down abruptly. Such behavior can cause the wheels to lock, possibly leading to loss of vehicle control.

An anti-lock brake system (ABS) enhances your vehicle's braking performance on snowy and icy roads. For information on braking on slippery surfaces, refer to “ABS (Anti-lock Brake System)” ¶7-32 and “Vehicle Dynamics Control system” ¶7-34.

WARNING

**For models with cruise control:
Do not use the cruise control on slippery roads such as snowy or icy**

roads. This may cause loss of vehicle control.

 **CAUTION**

Avoid prolonged continuous driving in snowstorms. Snow will enter the engine's intake system and may hinder the airflow, which could result in engine shutdown or even breakdown.

▼ **Wiper operation when snowing**

Before driving in cold weather, make sure the wiper blade rubbers are not frozen to the windshield or rear window.

If the wiper blade rubbers are frozen to the windshield or rear window, perform the following procedure.

- To thaw the windshield wiper blade rubbers, use the defroster with the airflow selection in “” and the temperature set for maximum warmth until the wiper blade rubbers are completely thawed. Refer to “Climate control” ¶4-1.
- If your vehicle is equipped with a wiper deicer, use it. It is helpful to thaw the windshield wiper blade rubbers. Refer to “Defogger and deicer” ¶3-88.
- To thaw the rear wiper blade rubbers,

use the rear window defogger. Refer to “Defogger and deicer” ¶3-88.

When driving in snow, if frozen snow starts to stick on the surface of the windshield despite wiper operation, use the defroster with the airflow selection in “” and the temperature set for maximum warmth. After the windshield gets warmed enough to melt the frozen snow on it, wash it away using the windshield washer. Refer to “Windshield washer” ¶3-77.

Snow stuck on the wiper arm prevents the wiper from working effectively. If snow is stuck on the wiper arm, pull off the road to a safe place, then remove it. If you stop the vehicle at road side, use the hazard warning flasher to alert other drivers. Refer to “Hazard warning flasher” ¶3-8.

■ Corrosion protection

Refer to “Corrosion protection” ¶10-4.

■ Snow tires

 **WARNING**

- **When replacing or installing winter tire(s), all four tires must be the same for following items.**
 - (a) Size

- (b) Circumference
- (c) Speed symbol
- (d) Load index
- (e) Construction
- (f) Manufacturer
- (g) Brand (tread pattern)
- (h) Degrees of wear

For the items (a) to (d), you must obey the specification that is printed on the tire placard. The tire placard is located on the driver's door pillar.

If all of four winter tires are not the same for items (a) to (h), serious mechanical damage could occur to the drive train of your car, and affect the following.

- Ride
- Handling
- Braking
- Speedometer/Odometer calibration
- Clearance between the body and tires

It also may be dangerous and lead to loss of vehicle control, and it can lead to an accident.

- **Do not use a combination of**

radial, belted bias or bias tires since it may cause dangerous handling characteristics and lead to an accident.

Your vehicle is equipped with “all season tires” as original equipment, which are designed to provide an adequate measure of traction, handling and braking performance in year-round driving. In winter, it may be possible to enhance performance through use of tires designed specifically for winter driving conditions.

When you choose to install winter tires on your vehicle, be sure to use the correct tire size and type. You must install four winter tires that are of the same size, construction, brand and load range and you should never mix radial, belted bias or bias tires since this may result in dangerous handling characteristics. When you choose a tire, make sure that there is enough clearance between the tire and vehicle body.

Remember to drive with care at all times regardless of the type of tires on your vehicle.

■ Tire chains



CAUTION

Tire chains cannot be used on your vehicle because of the lack of clearance between the tires and vehicle body.

NOTE

When tire chains cannot be used, use of another type of traction device (such as spring chains) may be acceptable if use on your vehicle is recommended by the device manufacturer, taking into account tire size and road conditions. Follow the device manufacturer's instructions, especially regarding maximum vehicle speed.

To help avoid damage to your vehicle, drive slowly, readjust or remove the device if it is contacting your vehicle, and do not spin your wheels. Damage caused to your vehicle by use of a traction device is not covered under warranty.

Make certain that any traction device you use is an SAE class S device, and use it on the front wheels only. Always use the utmost care when driving with a traction device. Overconfidence be-

cause you are using a traction device could easily lead to a serious accident.

■ Rocking the vehicle

If you must rock the vehicle to free it from snow, sand, or mud, depress the accelerator pedal slightly and move the shift lever/select lever back and forth between “1”/“D” and “R” repeatedly. Do not race the engine. For the best possible traction, avoid spinning the wheels when trying to free the vehicle.

When the road surface is extremely slippery, you can obtain better traction by starting the vehicle with the transmission in 2nd than 1st (both for MT and CVT models).

If your vehicle is a CVT model, for information about holding the transmission in the 2nd position, refer to “Selection of manual mode” ¶7-26.

Loading your vehicle

⚠ WARNING

- Never allow passengers to ride on a folded rear seatback, in the trunk or in the cargo area. Doing so may result in serious injury.
- Never stack luggage or other cargo higher than the top of the seatback because it could tumble forward and injure passengers in the event of a sudden stop or accident. Keep luggage or cargo low, as close to the floor as possible.

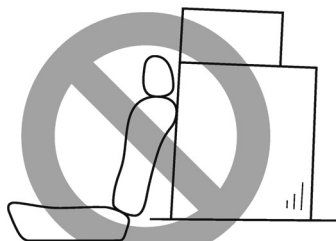

100094

⚠ WARNING

- When you carry something inside the vehicle, secure it whenever you can to prevent it from being thrown around inside the vehicle during sudden stops, sharp turns or in an accident.
- Do not pile heavy loads on the roof. These loads raise the vehicle's center of gravity and make it more prone to tip over.
- Secure lengthy items properly to prevent them from shooting forward and causing serious injury during a sudden stop.
- Never exceed the maximum load limit. If you do, some parts on your vehicle can break, or it can change the way your vehicle handles. This could result in loss of control and cause personal injury. Also, overloading can shorten the life of your vehicle.
- Do not place anything on the rear shelf behind the rear seatback (for sedan) or the extended cargo area cover (for 5-door models). Such items could tumble forward in the event of a sudden stop or a collision. This could cause ser-

ious injury.

⚠ CAUTION

Do not carry spray cans, containers with flammable or corrosive liquids or any other dangerous items inside the vehicle.

NOTE

For better fuel economy, do not carry unneeded cargo.

■ Vehicle capacity weight

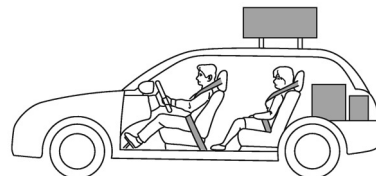

800440

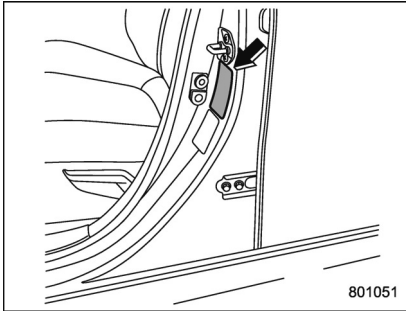

Vehicle placard

The load capacity of your vehicle is determined by weight, not by available cargo space. The maximum load you can carry in your vehicle is shown on the vehicle placard attached to the driver's side door pillar. It includes the total weight of the driver and all passengers and their belongings, any optional equipment such as a roof rack or bike carrier, etc.,

■ GVWR and GAWR (Gross Vehicle Weight Rating and Gross Axle Weight Rating)

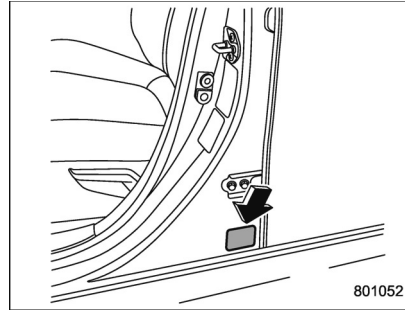

Certification label

The certification label attached to the bottom of driver's side door pillar shows GVWR (Gross Vehicle Weight Rating) and GAWR (Gross Axle Weight Rating).

The GVW (Gross Vehicle Weight) must never exceed the GVWR. GVW is the combined total of weight of the vehicle, fuel, driver, all passengers, luggage, any optional equipment and trailer tongue load. Therefore, the GVW changes depending on the situation. The GVWR equals Curb Weight (actual weight of your vehicle – including standard equipment, fluids, emergency tools and spare tire

assembly) plus the vehicle capacity weight.

In addition, the total weight applied to each axle (GAW) must never exceed the GAWR. The front and rear GAWs can be adjusted by relocating luggage inside the vehicle.

Even if the total weight of your luggage is lower than the vehicle capacity weight, either front or rear GAW may exceed the GAWR, depending on the distribution of the luggage.

When possible, the load should be evenly distributed throughout the vehicle.

If you carry heavy loads in the vehicle, you should confirm that GVW and front and rear GAWs are within the GVWR and GAWR by putting your vehicle on a vehicle scale, found at a commercial weighing station.

Do not use replacement tires with a lower load range than the originals because they may lower the GVWR and GAWR limitations. Replacement tires with a higher load range than the originals do not increase the GVWR and GAWR limitations.

■ Roof rail (if equipped)

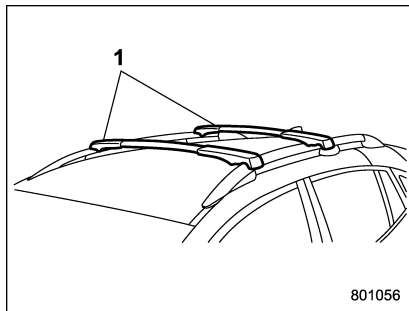

1) Crossbar

Cargo can be carried on the roof after securing the crossbars to the roof rails and installing an appropriate carrying attachment. When installing crossbars and a carrying attachment, follow the manufacturer's instructions. The roof rail system is designed to carry loads (cargo, crossbars and carrying attachment) of no more than **150 lbs (68 kg)**. Be sure not to exceed your vehicle's GVWR and GAWR.



CAUTION

- When using a carrying attachment, make sure that the total carrying load of the cargo, crossbars and carrying attachment

does not exceed 150 lbs (68 kg). Overloading may cause damage to the vehicle.

- For cargo carrying purposes, the roof rails must be used together with the crossbars and any appropriate carrying attachment that may be needed. The roof rails must never be used alone to carry cargo. Otherwise, damage to the roof or paint, or a dangerous road hazard due to loss of cargo could result.

NOTE

Remember that the vehicle's center of gravity is altered with the weight of the load on the roof, thus affecting driving characteristics.

Drive carefully. Avoid rapid starts, hard cornering and abrupt stops. Crosswind effects will be increased.

■ Roof molding and crossbar (if equipped)

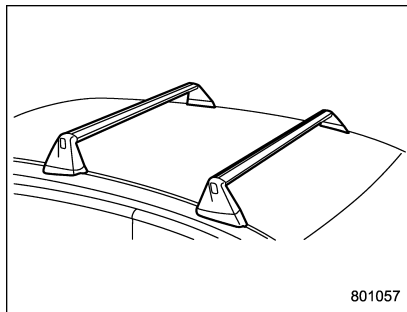

CAUTION

- For cargo carrying purposes, the roof molding must be used together with a roof crossbar kit and the appropriate carrying attachment. Otherwise, damage to the roof or paint or a dangerous road hazard due to loss of cargo could result.
- When using the roof crossbar kit, make sure that the total weight of the crossbars, carrying attachment and cargo does not exceed the maximum load limit. Overloading may cause damage to

the vehicle and create a safety hazard.

Cargo can be carried after securing the roof crossbar kit to the roof molding and installing the appropriate carrying attachment. When installing the roof crossbar kit, follow the manufacturer's instructions.

When carrying cargo on the roof using the roof crossbar kit and carrying attachments, never exceed the maximum load limit as explained below. You should also be careful that the vehicle does not exceed the Gross Vehicle Weight Rating (GVWR) and front and rear Gross Axle Weight Rating (GAWR). For information about loading cargo into or onto your vehicle, refer to "Loading your vehicle" 8-10. The maximum total load on the roof (including crossbars, carrying attachments and cargo) must not exceed **176 lbs (80 kg)**. Refer to the crossbar installation instructions for the maximum crossbar capacity. Place the heaviest load at the bottom, close to the roof, and evenly distribute the cargo. Always properly secure all cargo.

▼ **Installing carrying attachments on the crossbars**

When installing any carrying attachments such as the load carriers, crossbars, bike carrier, ski carrier, kayak carrier, cargo basket, etc., follow the manufacturer's instructions of the load capacity and make sure that the attachments are securely installed. Use only attachments designed specifically for the crossbars. Before operating the vehicle, make sure that the cargo is properly secured on the attachment.

NOTE

Remember that the vehicle's center of gravity is altered with the weight of the load on the roof, thus affecting the driving characteristics.

Drive carefully. Avoid rapid starts, hard cornering and abrupt stops. Crosswind effects will be increased.

▼ **Removal and installation of the crossbars**

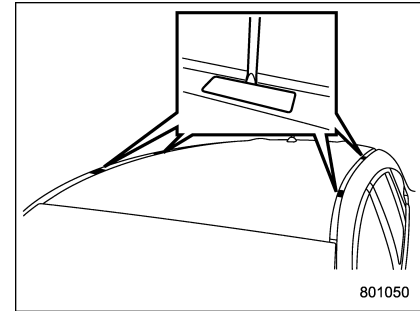

Each of the two roof moldings has two mounting points for crossbars. Each mounting point is fitted with a cover. Use a screwdriver to remove the covers. When installing the crossbars on the roof molding, follow the manufacturer's instructions.

Trailer towing



CAUTION

Your vehicle is neither designed nor intended to be used for trailer towing. Therefore, never tow a trailer with your vehicle.

SUBARU assumes no responsibility for injuries or vehicle damage that may result from trailer towing, from any trailer towing equipment or from any errors or omissions in the instructions accompanying such equipment. SUBARU warranties do not apply to vehicle damage or malfunction caused by trailer towing.

If you park your vehicle in case of an emergency	9-2	If no steam is coming from the engine compartment	9-13
Temporary spare tire	9-2	Towing	9-14
Maintenance tools	9-3	Towing hooks and tie-down hooks/holes	9-14
Tool locations	9-4	Using a flat-bed truck	9-16
Using the jack	9-5	Towing with all wheels on the ground	9-17
Flat tires	9-6	Access key fob – if access key fob does not operate properly	9-18
Changing a flat tire	9-6	Locking and unlocking	9-18
Tire pressure monitoring system (TPMS) (U.S.-spec. models)	9-9	Switching power status	9-18
Jump starting	9-10	Starting engine	9-19
How to jump start	9-11	Rear gate – if the rear gate cannot be opened	9-20
Engine overheating	9-13	Moonroof (if equipped) – if the moonroof does not close	9-20
If steam is coming from the engine compartment	9-13	If your vehicle is involved in an accident	9-21

If you park your vehicle in case of an emergency

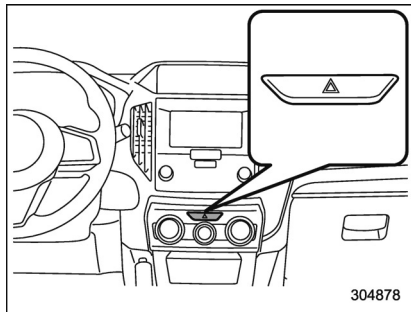

The hazard warning flasher should be used in day or night to warn other drivers when you have to park your vehicle under emergency conditions.

Avoid stopping on the road. It is best to safely pull off the road if a problem occurs.

The hazard warning flasher can be activated regardless of the ignition switch position.

Turn on the hazard warning by pushing the hazard warning flasher switch. Turn it off by pushing the switch again.

NOTE

When the hazard warning flasher is on, the turn signals do not work.

Temporary spare tire

WARNING

When a spare tire is mounted or a wheel rim is replaced without the original pressure sensor/transmitter being transferred, the low tire pressure warning light will illuminate steadily after blinking for approximately one minute. This indicates the tire pressure monitoring system (TPMS) is unable to monitor all four road wheels. Contact your SUBARU dealer as soon as possible for tire and sensor replacement and/or system resetting.

CAUTION

Never use any temporary spare tire other than the original. Using other sizes may result in severe mechanical damage to the drive train of your vehicle.

The temporary spare tire is smaller and lighter than a conventional tire and is designed for emergency use only. Remove the temporary spare tire and reinstall the conventional tire as soon as

possible because the spare tire is designed only for temporary use.

Check the inflation pressure of the temporary spare tire periodically to keep the tire ready for use. The correct pressure is **60 psi (420 kPa, 4.2 kgf/cm²)**.

When using the temporary spare tire, note the following.

- Drive with caution when the temporary spare tire is installed. Avoid hard acceleration and braking, or fast cornering, as control of the vehicle may be lost.
- Do not exceed 50 mph (80 km/h).
- Do not put a tire chain on the temporary spare tire. Because of the smaller tire size, a tire chain will not fit properly.
- Do not use two or more temporary spare tires at the same time.
- Do not drive over obstacles. This tire has a smaller diameter, so road clearance is reduced.

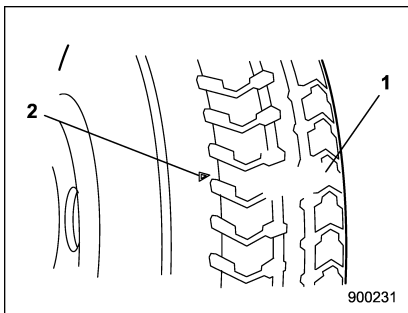

- 1) Tread wear indicator bar
- 2) Indicator location mark

- When the wear indicator appears on the tread, replace the tire.
- The temporary spare tire must be used only on a rear wheel. If a front wheel tire gets punctured, replace the wheel with a rear wheel and install the temporary spare tire in place of the removed rear wheel.

Maintenance tools

Your vehicle is equipped with the following maintenance tools.

- Jack
- Jack handle
- Screwdriver
- Towing hook (eye bolt)
- Wheel nut wrench

■ Tool locations

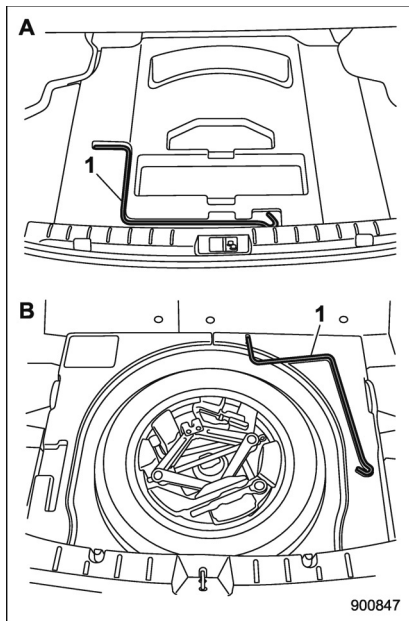

- 1) Jack handle
- A) Sedan
- B) 5-door models

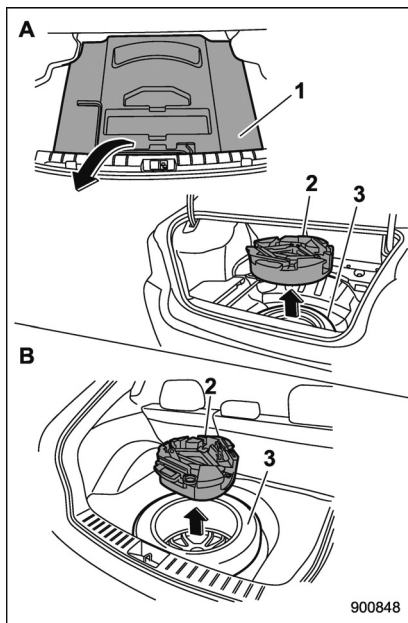

- 1) Under-floor storage compartment (if equipped) (Refer to "Under-floor storage compartment (sedan - if equipped)" 6-14.)
- 2) Tool bucket
- 3) Spare tire
- A) Sedan
- B) 5-door models

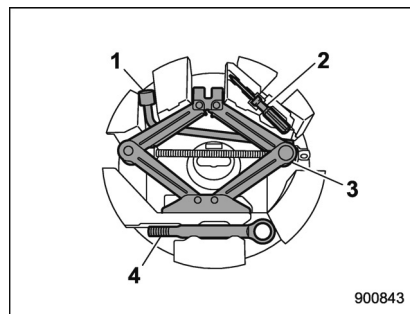

- 1) Wheel nut wrench
- 2) Screwdriver
- 3) Jack
- 4) Towing hook (eye bolt)

A jack handle is stored under the floor of the trunk (sedan) or the cargo area (5-door models). A jack and a towing hook are stored in the tool bucket that is located in the recess of the spare tire wheel.

Also, a tool bag that contains a wheel nut wrench and a screwdriver is equipped with the vehicle. Open the tool bag and store the tools in the tool bucket as illustrated in order that all tools are ready for use at any time.

■ Using the jack

1. Park on a hard, level surface, whenever possible, then stop the engine.
2. Apply the parking brake securely and shift the shift lever in reverse (MT models) or the select lever to the "P" (Park) position (CVT models).
3. Turn on the hazard warning flasher and have everyone get out of the vehicle.

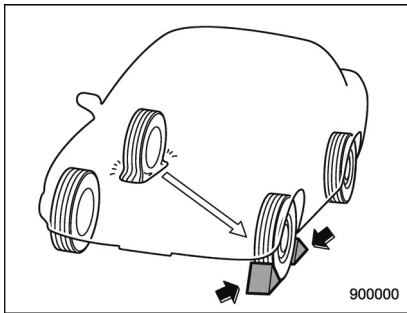

4. Put wheel blocks at the front and rear of the tire diagonally opposite the tire that you are going to replace.
5. Take out the jack and jack handle.

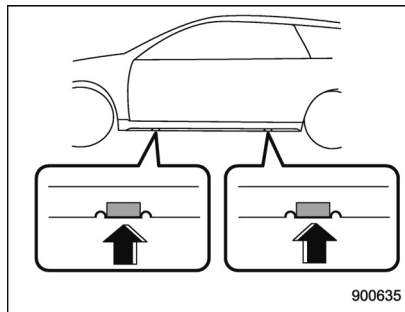

Jack-up points (type A models)

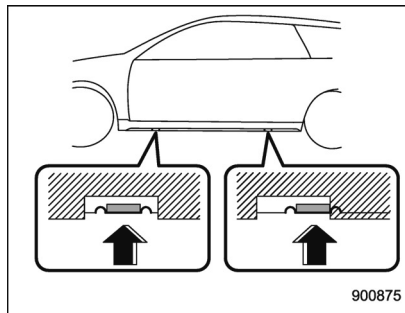

Jack-up points (type B models)

6. Place the jack under the side sill at the front or rear jack-up point closest to the tire that you are going to replace.

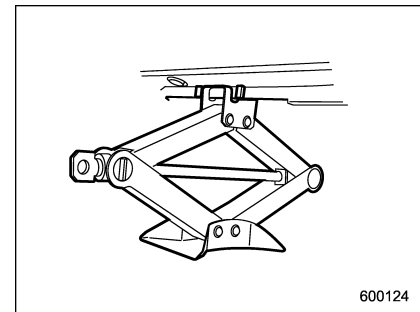

Turn the jackscrew by hand until the jack head engages firmly into the jack-up point.

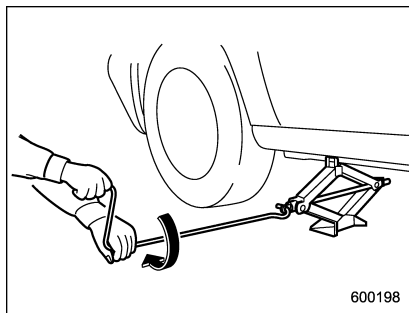

7. Insert the jack handle into the jack-screw, and turn the handle until the tire clears the ground. Do not raise the vehicle higher than necessary.

Flat tires

If you have a flat tire while driving, never brake suddenly; keep driving straight ahead while gradually reducing speed. Then slowly pull off the road to a safe place.

■ Changing a flat tire

WARNING

- Do not jack up the vehicle on an incline or a loose road surface. The jack can come out of the jacking point or sink into the ground and this can result in a severe accident.
- Use only the jack provided with your vehicle. The jack supplied with the vehicle is designed only for changing a tire. Never get under the vehicle while supporting the vehicle with this jack.
- Always turn off the engine before raising the flat tire off the ground using the jack. Never swing or push the vehicle supported with the jack. The jack can come out of the jacking point due to a jolt and this can result in a severe

accident.

1. Park on a hard, level surface, whenever possible, then stop the engine.
2. Apply the parking brake securely and shift the shift lever in reverse (MT models) or the select lever to the "P" (Park) position (CVT models).
3. Turn on the hazard warning flasher and have everyone get out of the vehicle.

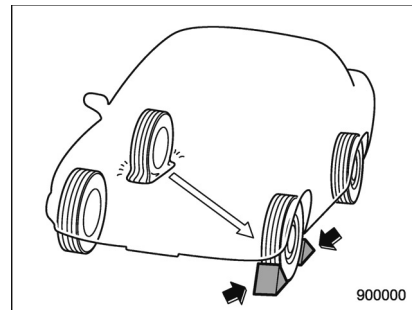

4. Put wheel blocks at the front and rear of the tire diagonally opposite the flat tire.
5. Take out the jack, jack handle and wheel nut wrench.

The tools and the spare tire are stored under the floor of the trunk (sedan) or the cargo area (5-door models). Refer to "Maintenance tools" 9-3.

NOTE

Make sure that the jack is well lubricated before using it.

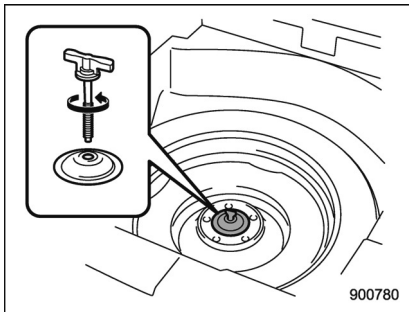

6. Take out the tool bucket and turn the attaching bolt counterclockwise, then take the spare tire out.

NOTE

If the spare tire provided in your vehicle is a temporary spare tire, carefully read "Temporary spare tire" 9-2 and strictly follow the instructions.

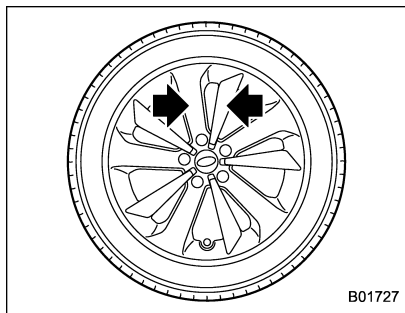

7. If your vehicle has wheel covers, remove them by holding and pulling the areas indicated in the illustration.

CAUTION

Use gloves to protect your hands when removing wheel covers.

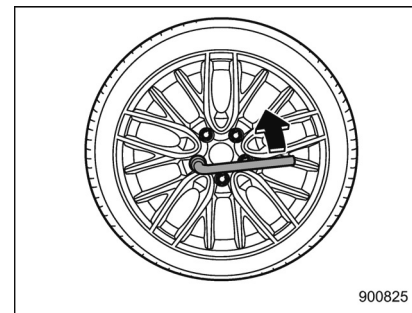

8. Loosen the wheel nuts using the wheel nut wrench but do not remove the nuts.

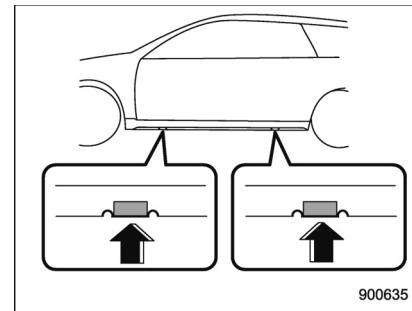

Jack-up points (type A models)

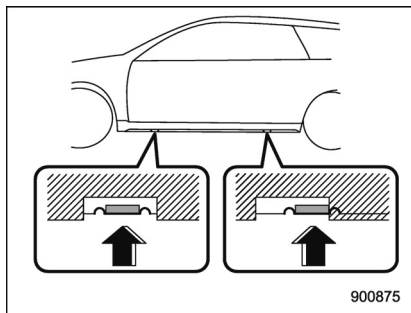

Jack-up points (type B models)

9. Place the jack under the side sill at the front or rear jack-up point closest to the flat tire.

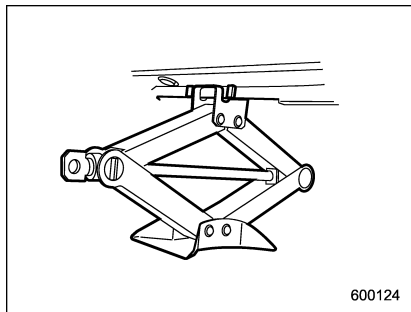

Turn the jackscrew by hand until the jack head engages firmly into the jack-up point.

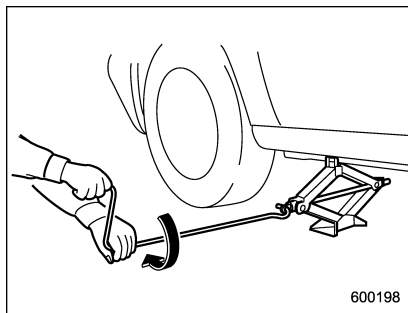

10. Insert the jack handle into the jackscrew, and turn the handle until the tire clears the ground. Do not raise the vehicle higher than necessary.

11. Remove the wheel nuts and the flat tire.

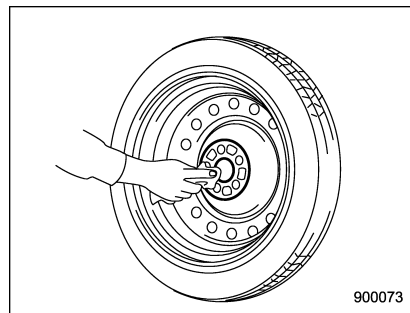
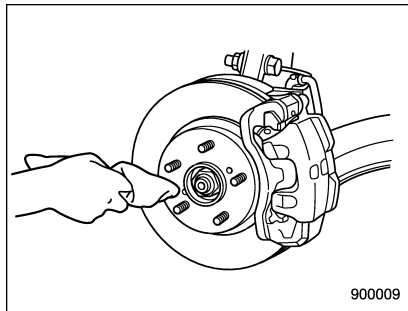

12. Before putting the spare tire on, clean the mounting surface of the wheel and hub with a cloth.

13. Put on the spare tire. Replace the wheel nuts. Tighten them by hand.

WARNING

Do not use oil or grease on the wheel studs or nuts when the spare tire is installed. This could cause the nuts to become loose and lead to an accident.

14. Turn the jack handle counterclockwise to lower the vehicle.

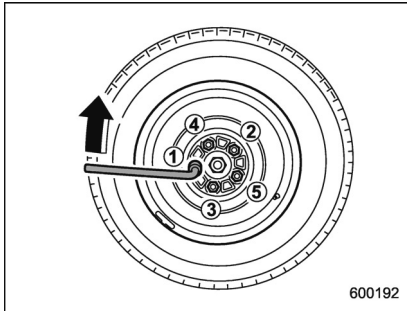

600192

15. Use the wheel nut wrench to securely tighten the wheel nuts to the specified torque, following the tightening order in the illustration.

For the wheel nut tightening torque, refer to "Tires" 12-8. Never use your foot on the wheel nut wrench or a pipe extension on the wrench because you may exceed the specified torque. Have the wheel nut torque checked at the nearest automotive service facility.

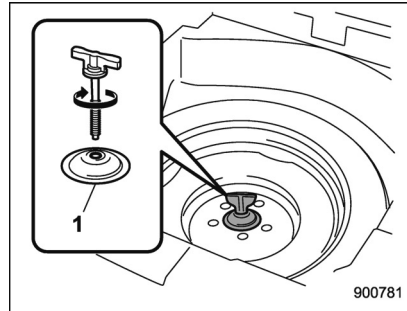

900781

1) Support holder

16. Store the flat tire in the spare tire compartment. Install with the support holder facing upward and secure the flat tire by firmly tightening the attaching bolt.

NOTE

If you cannot fix the flat tire firmly, try turning the support holder upside down.

17. Store the jack, jack handle and wheel nut wrench in their storage locations.

WARNING

Never place a tire or tire changing tools in the passenger compartment after changing wheels. In a sudden

stop or collision, loose equipment could strike occupants and cause injury. Store the tire and all tools in the proper place.

■ Tire pressure monitoring system (TPMS) (U.S.-spec. models)

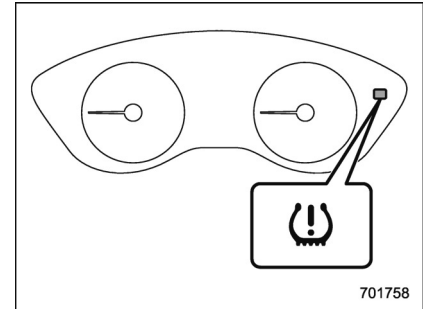

701758

The tire pressure monitoring system provides the driver with the warning message indicated by sending a signal from a sensor that is installed in each wheel when tire pressure is severely low.

The tire pressure monitoring system will activate only when the vehicle is driven. Also, this system may not react immediately to a sudden drop in tire pressure (for example, a blow-out caused running over

a sharp object).

 **WARNING**

- If the low tire pressure warning light illuminates while driving, never brake suddenly. Instead, perform the following procedure.

(1) Keep driving straight ahead while gradually reducing speed.

(2) Slowly pull off the road to a safe place. Otherwise an accident involving serious vehicle damage and serious personal injury could occur.

(3) Check the pressure for all four tires and adjust the pressure to the COLD tire pressure shown on the vehicle placard on the door pillar on the driver's side.

If this light still illuminates while driving after adjusting the tire pressure, a tire may have significant damage and a fast leak that causes the tire to lose air rapidly. If you have a flat tire, replace it with a spare tire as soon as possible.

- When a spare tire is mounted or a

wheel rim is replaced without the original pressure sensor/transmitter being transferred, the low tire pressure warning light will illuminate steadily after blinking for approximately one minute. This indicates the TPMS is unable to monitor all four road wheels. Contact your SUBARU dealer as soon as possible for tire and sensor replacement and/or system resetting.

- When a tire is repaired with liquid sealant, the tire pressure warning valve and transmitter may not operate properly. If a liquid sealant is used, contact your nearest SUBARU dealer or other qualified service shop as soon as possible. Make sure to replace the tire pressure warning valve and transmitter when replacing the tire. You may reuse the wheel if there is no damage to it and if the sealant residue is properly cleaned off.

If the light illuminates steadily after blinking for approximately one minute, promptly contact a SUBARU dealer to have the system inspected.

Jump starting

 **WARNING**

- Battery fluid is SULFURIC ACID. Do not let it come in contact with the eyes, skin, clothing or the vehicle.

If battery fluid gets on you, thoroughly flush the exposed area with water immediately. Get medical help if the fluid has entered your eyes.

If battery fluid is accidentally swallowed, immediately drink a large amount of milk or water, and obtain immediate medical help.

Keep everyone including children away from the battery.

- The gas generated by a battery explodes if a flame or spark is brought near it. Do not smoke or light a match while jump starting.
- Never attempt jump starting if the discharged battery is frozen. It could cause the battery to burst or explode.
- Whenever working on or around a battery, always wear suitable

eye protectors, and remove metal objects such as rings, bands or other metal jewelry.

- Be sure the jumper cables and clamps on them do not have loose or missing insulation.

Do not jump start unless cables in suitable condition are available.

- A running engine can be dangerous. Keep your fingers, hands, clothing, hair and tools away from the cooling fan, belts and any other moving engine parts. Removing rings, watches and ties is advisable.
- Jump starting is dangerous if it done incorrectly. If you are unsure about the proper procedure for jump starting, consult a competent mechanic.

When your vehicle does not start due to a run down (discharged) battery, the vehicle may be jump started by connecting your battery to another battery (called the booster battery) with jumper cables.

■ How to jump start

1. Make sure the booster battery is 12 volts and the negative terminal is grounded.
2. If the booster battery is in another vehicle, do not let the two vehicles touch.
3. Turn off all unnecessary lights and accessories.
4. Connect the jumper cables exactly in the sequence illustrated.

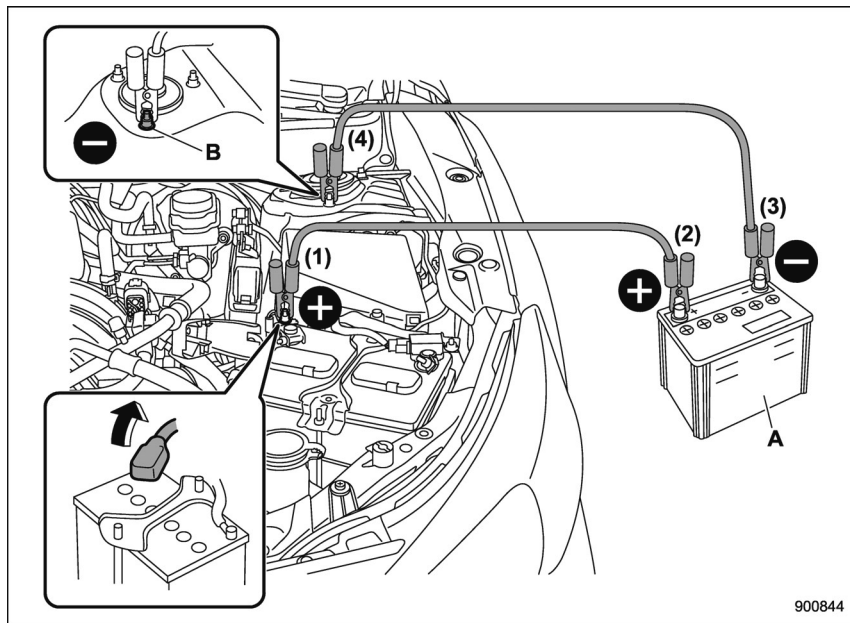

A) Booster battery
B) Strut mounting nut

(1) Connect one jumper cable to the positive (+) terminal on the discharged battery.

(2) Connect the other end of the jumper cable to the positive (+) terminal of the booster battery.

(3) Connect one end of the other cable to the negative (-) terminal of the booster battery.

(4) Connect the other end of the cable to the strut mounting nut of the vehicle with the discharged battery.

Make sure that the cables are not near any moving parts and that the cable clamps are not in contact with any other metal.

5. Start the engine of the vehicle with the booster battery and run it at moderate speed. Then start the engine of the vehicle that has the discharged battery.

6. When finished, carefully disconnect the cables in exactly the reverse order.

900844

Engine overheating

WARNING

Never attempt to remove the radiator cap until the engine has been shut off and has fully cooled down. When the engine is hot, the coolant is under pressure. Removing the cap while the engine is still hot could release a spray of boiling hot coolant, which could burn you very seriously.

If the engine overheats, safely pull off the road and stop the vehicle in a safe location.

■ If steam is coming from the engine compartment

- Turn the ignition switch to the “LOCK”/“OFF” position and get everyone away from the vehicle until it cools down.
- Contact an authorized SUBARU dealer.

■ If no steam is coming from the engine compartment

1. Keep the engine running at idling speed.
2. Open the engine hood to ventilate the engine compartment. Refer to “Engine hood” ☞ 11-5.

Confirm that the cooling fan is turning. If the fan is not turning, immediately turn off the engine and contact an authorized SUBARU dealer for repair.

3. After the coolant temperature high warning light that has blinked or illuminated in **RED** turns off, turn off the engine. For details about the warning light, refer to “Coolant temperature low indicator light/ Coolant temperature high warning light” ☞ 3-17.

4. After the engine has fully cooled down, check the coolant level in the reserve tank. If the coolant level is below the “LOW” mark, add coolant up to the “FULL” mark.

NOTE

For details about how to check the coolant level or how to add coolant, refer to “Engine coolant” ☞ 11-11.

5. If there is no coolant in the reserve tank, add coolant to the reserve tank. Then remove the radiator cap and fill the

radiator with coolant.

If you remove the radiator cap from a hot radiator, first wrap a thick cloth around the radiator cap, then turn the cap counter-clockwise slowly without pressing down until it stops. Release the pressure from the radiator. After the pressure has been fully released, remove the cap by pressing down and turning it.

Towing

If towing is necessary, it is best done by your SUBARU dealer or a commercial towing service. Observe the following procedures for safety.

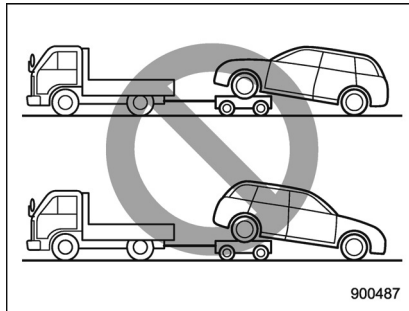

900487

WARNING

Never tow AWD models with the front wheels raised off the ground while the rear wheels are on the ground, or with the rear wheels raised off the ground while the front wheels are on the ground. This will cause the vehicle to spin away due to the operation or deterioration of the center differential.

■ Towing hooks and tie-down hooks/holes

The towing hooks should be used only in an emergency (e.g., to free a stuck vehicle from mud, sand or snow).

CAUTION

- Use only the specified towing hooks and tie-down hooks/holes. Never use suspension parts or other parts of the body for towing or tie-down purposes.
- To prevent deformation to the front bumper and the towing hook, do not apply excessive lateral load to the towing hooks.

▼ Front towing hook

1. Take the towing hook and screwdriver out of the tool bucket. Take the jack handle out of the trunk (sedan) or cargo area (5-door models).

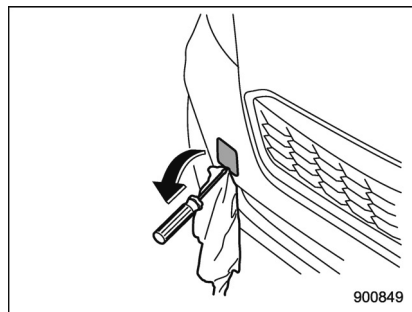

900849

2. Cover the tip of a flat-head screwdriver with vinyl tape or cloth so that it will not scratch the bumper. Insert the flat-head screwdriver into the cutout of the cover and pry open the cover.

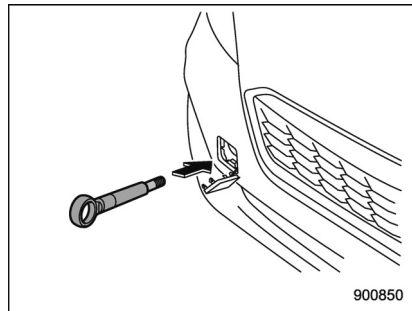

900850

3. Screw the towing hook into the thread

hole until its thread can no longer be seen.

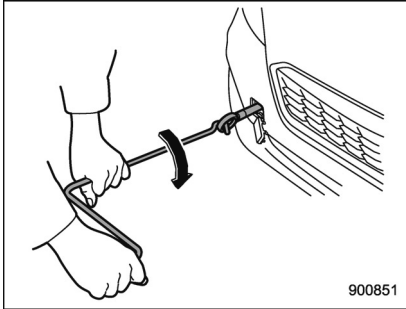

4. Tighten the towing hook securely using the jack handle.

After towing, remove the towing hook from the vehicle and stow it in the tool bucket. Fit the towing hook cover on the bumper.

⚠ WARNING

- Do not use the towing hook except when towing your vehicle.
- Be sure to remove the towing hook after towing. Leaving the towing hook mounted on the vehicle could interfere with proper operation of the SRS airbag system in a frontal collision.

▼ **Rear towing hook**

1. Take the towing hook and screwdriver out of the tool bucket. Take the jack handle out of the trunk (sedan) or cargo area (5-door models).

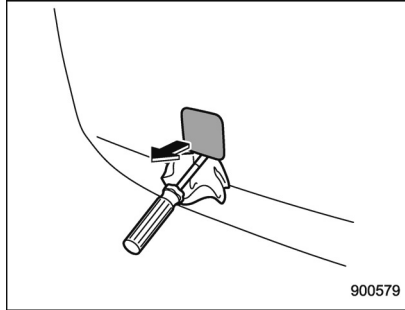

2. Cover the tip of a flat-head screwdriver with vinyl tape or cloth so that it will not scratch the bumper. Pry off the cover on the rear bumper using a screwdriver, and you will find a threaded hole for attaching the towing hook.

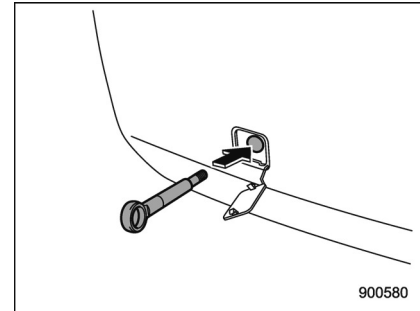

3. Screw the towing hook into the thread hole until its thread can no longer be seen.

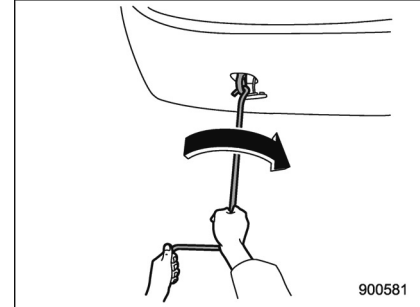

4. Tighten the towing hook securely using the jack handle.

After towing, remove the towing hook from

the vehicle and stow it in the tool bucket. Fit the towing hook cover on the bumper.

WARNING

- Do not use the towing hook except when towing your vehicle.
- Be sure to remove the towing hook after towing. Leaving the towing hook mounted on the vehicle could interfere with proper operation of the fuel pump shut off function when the vehicle is struck from behind.

▼ Front tie-down hooks

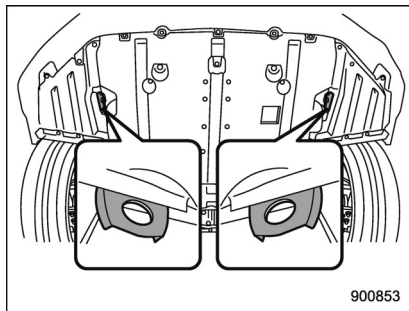

The front tie-down hooks are located between each of the front tires and the front bumper.

▼ Rear tie-down holes

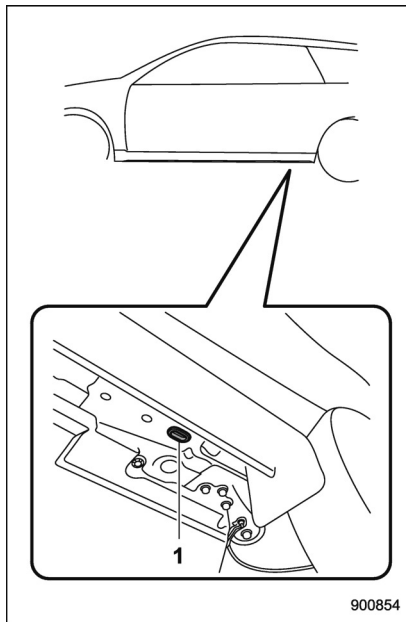

1) Rear tie-down hole

The rear tie-down holes are located near each of the jack-up reinforcements. There is a plug in each rear tie-down hole. To use the rear tie-down holes, remove

the plugs. After using the rear tie-down holes, return the plugs to their original places.

WARNING

Use the rear tie-down holes only for downward anchoring. If they are used to anchor the vehicle in any other direction, cables may slip out of the holes, possibly causing a dangerous situation.

■ Using a flat-bed truck

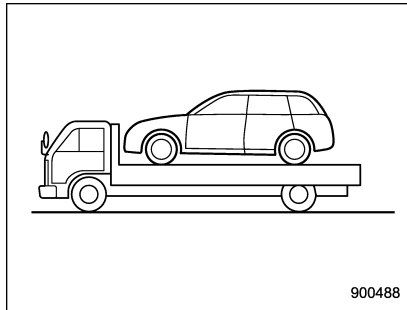

This is the best way to transport your vehicle. Use the following procedures to ensure safe transportation.

1. Shift the select lever into the "P" position for CVT models. Shift the shift

- lever into the "1st" position for MT models.
2. Pull up the parking brake lever firmly.
 3. Secure the vehicle onto the carrier properly with safety chains. Each safety chain should be equally tightened and care must be taken not to pull the chains so tightly that the suspension bottoms out.

CAUTION

If your vehicle has a front under-spoiler (optional), be careful not to scrape it when placing the vehicle on the carrier and when removing the vehicle from the carrier.

Towing with all wheels on the ground

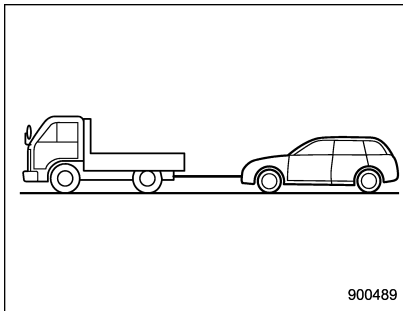

1. Release the parking brake and put the transmission in the "N" position.
2. The ignition switch should be in the "ON" position while the vehicle is being towed.
3. Take up slack in the towline slowly to prevent damage to the vehicle.

WARNING

- Never turn the ignition switch to the "LOCK"/"OFF" position while the vehicle is being towed because the steering wheel and the direction of the wheels will be locked.

- Remember that the brake booster and power steering do not function when the engine is not running. Because the engine is turned off, it will take greater effort to operate the brake pedal and steering wheel.

CAUTION

- If transmission failure occurs, transport your vehicle on a flat-bed truck.
- For CVT models, the traveling speed must be limited to less than 20 mph (30 km/h) and the traveling distance to less than 31 miles (50 km). For greater speeds and distances, transport your vehicle on a flat-bed truck.

Access key fob – if access key fob does not operate properly

CAUTION

Keep metallic objects, magnetic sources and signal transmitters away from the area between the access key fob and the push-button ignition switch. They may interfere with the communication between the access key fob and the push-button ignition switch.

The following functions may be inoperable because of strong radio signals in the surrounding area or a low battery condition of the access key fob.

- Locking/unlocking doors (including the rear gate for 5-door models)
- Switching power status
- Starting engine

In such cases, perform the following procedure. When the battery of the access key fob is discharged, replace it with a new one. Refer to “Replacing battery of access key fob” 2-11-45.

Locking and unlocking

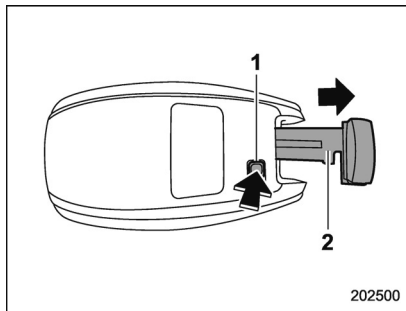

- 1) Release button
- 2) Emergency key

While pressing the release button of the access key fob, take out the emergency key.

Lock or unlock the driver's door with the emergency key in the procedure described in “Locking and unlocking from the outside” 2-23.

NOTE

After locking or unlocking, be sure to attach the emergency key back to the access key fob.

Switching power status

1. Apply the parking brake.
2. Shift the shift lever to neutral (MT models) or the select lever to the “P” (Park) position (CVT models).
3. Depress the clutch pedal (MT models) or brake pedal (CVT models).

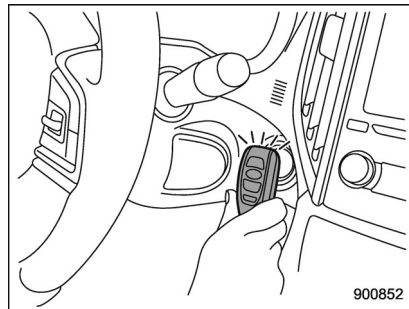

4. Hold the access key fob with the buttons facing you, and touch the push-button ignition switch with it.

When the communication between the access key fob and the vehicle is completed, a chime (ding) will sound. At the same time, the status of the push-button ignition switch changes to either of the following.

- When the keyless access with push-button start system is deactivated:

“ACC”

- Under other conditions: “ON”

5. When the keyless access with push-button start system is deactivated, press the push-button ignition switch with the clutch pedal (MT models) or brake pedal (CVT models) released. The status of the push-button ignition switch then changes to “ON”.

NOTE

If the power does not switch even though the above procedure was followed precisely, contact your SUBARU dealer.

■ Starting engine

1. Apply the parking brake.
2. Shift the shift lever to neutral (MT models) or the select lever to the “P” (Park) position (CVT models).
3. Depress the brake pedal.
4. Depress the clutch pedal (MT models).

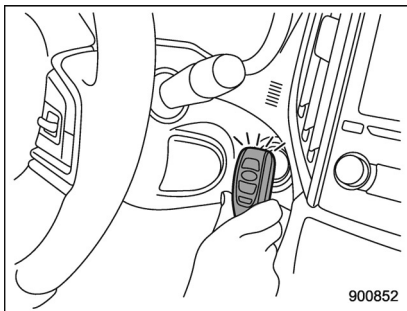

5. Hold the access key fob with the buttons facing you, and touch the push-button ignition switch with it.

When the communication between the access key fob and the vehicle is completed, a chime (ding) will sound. At the same time, the push-button ignition switch turns to the “ACC” or “ON” position.

6. After the push-button ignition switch turns to the “ACC” or “ON” position, while depressing the brake pedal (all models) and the clutch pedal (MT models), press the push-button ignition switch.

NOTE

If the engine does not start even though the above procedure was followed precisely, contact your SUBARU dealer.

Rear gate – if the rear gate cannot be opened

In the event that you cannot open the rear gate by operating the rear gate opener button, you can open it from inside the cargo area.

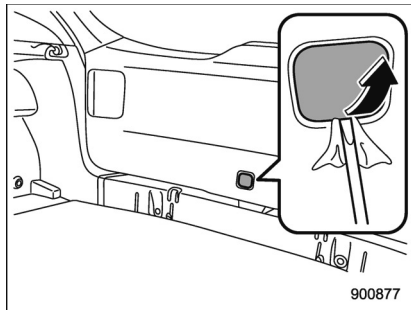

1. Remove the access cover at the bottom-center of the rear gate trim using a flat-head screwdriver wrapped with vinyl tape or a cloth.
2. Locate the rear gate open lever behind the rear gate trim panel.

CAUTION

Never operate the rear gate open lever with fingers because doing so may cause an injury. Always use a flat-head screwdriver or a similar tool.

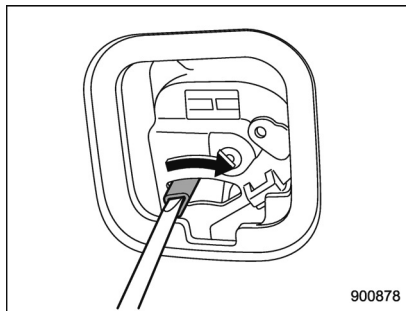

3. To open the rear gate, turn the lever to the right position using a flat-head screwdriver or a similar tool.

Moonroof (if equipped) – if the moonroof does not close

If the moonroof does not close, we recommend that you have the system checked by a SUBARU dealer.

If your vehicle is involved in an accident

 **CAUTION**

If your vehicle is involved in an accident, be sure to inspect the ground under the vehicle before restarting the engine. If you find that fuel has leaked on the ground, do not try to restart the engine. The fuel system has been damaged and is in need of repair. Immediately contact the nearest automotive service facility. We recommend that you consult your SUBARU dealer.

Your vehicle has a fuel pump shut off system. When the vehicle sustains an impact in an accident, etc., the fuel pump shut off system stops supplying the fuel in order to minimize fuel leakage. However, depending on the impact conditions at the time of collision, the fuel pump shut-off system may not operate.

Perform the following procedures to restart the engine after the system is activated.

Models without “keyless access with push-button start system”:

1. Turn the ignition switch to the “LOCK” or “ACC” position.
2. Restart the engine.

Models with “keyless access with push-button start system”:

1. Turn the push-button ignition switch to the “ACC” or “OFF” position.
2. Restart the engine.

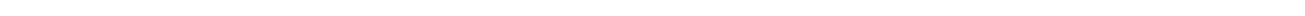
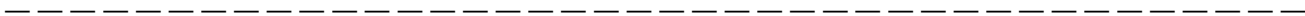
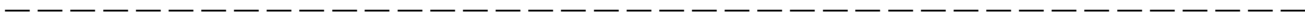

Exterior care	10-2	Cleaning the interior	10-5
Washing.....	10-2	Seat fabric.....	10-5
Waxing and polishing.....	10-3	Leather seat materials.....	10-6
Cleaning aluminum wheels.....	10-4	Synthetic leather upholstery.....	10-6
Corrosion protection	10-4	Seatbelt.....	10-6
Most common causes of corrosion.....	10-4	Climate control panel, audio panel, instrument panel, console panel, and switches	10-6
To help prevent corrosion.....	10-5	Monitor.....	10-7

Exterior care

■ Washing

CAUTION

- When washing the vehicle, the brakes may get wet. As a result, the brake stopping distance will be longer. To dry the brakes, drive the vehicle at a safe speed while lightly depressing the brake pedal to heat up the brakes.
- Do not wash the engine compartment and area adjacent to it. If water enters the engine air intake or electrical parts, it will cause engine trouble or a malfunction of electrical equipment.
- When washing inner fenders, underbody, bumpers and protruding objects such as exhaust pipes and exhaust finishers, be careful to prevent injuries from contacting sharp ends.
- Do not use any organic solvents when washing the surface of the bulb assembly cover. However, if a detergent with organic solvents is used to wash the cover surface, completely rinse off the

detergent with water. Otherwise, the cover surface may be damaged.

- For 5-door models, since your vehicle is equipped with a rear wiper, automatic car-wash brushes could become tangled around it, damaging the wiper arm and other components. Ask the automatic car-wash operator not to let the brushes touch the wiper arm or to fix the wiper arm on the rear window glass with adhesive tape before operating the machine.
- For models with a rod-type roof antenna, remove the antenna rod before washing your car at a car wash. If the antenna rod remains attached, it may scratch the roof. When reinstalling the removed antenna rod, be sure to fully tighten it.

NOTE

- When having your vehicle washed in an automatic car wash, make sure beforehand that the car wash is of suitable type.
- The rear view camera lens has a hard coating to help prevent scratches.

However, when washing the vehicle or cleaning the camera lens, be careful not to scratch the camera lens. Do not use a washing brush directly on the camera lens. The image quality of the rear view camera may deteriorate.

The best way to preserve your vehicle's beauty is frequent washing. Wash the vehicle at least once a month to avoid contamination by road grime.

Wash dirt off with a wet sponge and plenty of lukewarm or cold water. Do not wash the vehicle with hot water and in direct sunlight.

Salt, chemicals, insects, tar, soot, tree sap, and bird droppings should be washed off by using a light detergent, as required. If you use a light detergent, make certain that it is a neutral detergent. Do not use strong soap or chemical detergents. All cleaning agents should be promptly flushed from the surface and not allowed to dry there. Rinse the vehicle thoroughly with plenty of lukewarm water. Wipe the remaining water off with a chamois or soft cloth. Wear rubber gloves and use a hand brush when washing down underbody, inner fenders and suspension to effectively remove mud and dirt off.

▼ Washing the underbody

Chemicals, salts and gravel used for deicing road surfaces are extremely corrosive, accelerating the corrosion of underbody components, such as the exhaust system, fuel and brake lines, brake cables, floor pan and fenders, and suspension.

Thoroughly flush the underbody and inside of the fenders with lukewarm or cold water at frequent intervals to reduce the harmful effects of such agents.

Mud and sand adhering to the underbody components may accelerate their corrosion.

After driving off-road or on muddy or sandy roads, wash the mud and sand off the underbody. Carefully flush the suspension and axle parts, as they are particularly prone to mud and sand buildup. Do not use a sharp-edged tool to remove caked mud.

 **CAUTION**

- **Be careful not to damage brake hoses, sensor harnesses, and other parts when washing suspension components.**
- **Be careful not to flush the engine bottom for a long time. It may**

cause damage of some electrical parts.

▼ Using a warm water washer

- Keep a good distance of 12 in (30 cm) or more between the washer nozzle and the vehicle.
- Do not wash the same area continuously.
- If a stain will not come out easily, wash by hand. Some warm water washers are of the high temperature, high pressure type, and they can damage or deform the resin parts such as moldings, or cause water to leak into the vehicle.

■ Waxing and polishing

Always wash and dry the vehicle before waxing and polishing.

Use a good quality polish and wax and apply them according to the manufacturer's instructions. Wax or polish when the painted surface is cool.

Be sure to polish and wax the chrome trim, as well as the painted surfaces. Loss of wax on a painted surface leads to loss of the original luster and also quickens the deterioration of the surface. It is recommended that a coat of wax be applied at least once a month, or whenever the surface no longer repels water.

If the appearance of the paint has diminished to the point where the luster or tone cannot be restored, lightly polish the surface with a fine-grained compound. Never polish just the affected area, but include the surrounding area as well. Always polish in only one direction. A No. 2000 grain compound is recommended. Never use a coarse-grained compound. Coarse-grained compounds have a smaller grain-size number and could damage the paint. After polishing with a compound, coat with wax to restore the original luster. Frequent polishing with a compound or an incorrect polishing technique will result in removing the paint layer and exposing the undercoat. When in doubt, it is always best to contact your SUBARU dealer or an auto paint specialist.

 **CAUTION**

Do not use any agents with organic solvents on the surface of the bulb assembly cover. However, if a polish or wax with organic solvents is applied to the cover surface, completely wipe off the polish or wax. Otherwise, the cover surface may be damaged.

NOTE

- Be careful not to block the windshield washer nozzles with wax when waxing the vehicle.
- Do not wipe the rear view camera with alcohol, benzine or paint thinner. Otherwise, discoloration may occur. To remove contamination, wipe the camera with a cloth moistened with diluted neutral detergent and then wipe it with a soft, dry cloth.
- When waxing the vehicle, be careful not to apply the wax to the rear view camera. If it comes in contact with the camera, moisten a clean cloth with diluted neutral detergent to remove the wax.

■ Cleaning aluminum wheels

- Promptly wipe the aluminum wheels clean of any kind of grime or agent. If dirt is left on too long, it may be difficult to clean off.
- Do not use soap containing grit to clean the wheels. Be sure to use a neutral cleaning agent, and later rinse thoroughly with water. Do not clean the wheels with a stiff brush or expose them to a high-speed washing device.
- Clean the vehicle (including the aluminum wheels) with water as soon as

possible when it has been splashed with sea water, exposed to sea breezes, or driven on roads treated with salt or other agents.

Corrosion protection

Your SUBARU has been designed and built to resist corrosion. Special materials and protective finishes have been used on most parts of the vehicle to help maintain fine appearance, strength, and reliable operation.

■ Most common causes of corrosion

The most common causes of corrosion are:

- The accumulation of moisture retaining dirt and debris in body panel sections, cavities, and other areas.
- Damage to paint and other protective coatings caused by gravel and stone chips or minor accidents.

Corrosion is accelerated on the vehicle when:

- It is exposed to road salt or dust control chemicals, or used in coastal areas where there is more salt in the air, or in areas where there is considerable industrial pollution.
- It is driven in areas of high humidity, especially when temperatures range just above freezing.
- Dampness in certain parts of the

vehicle remains for a long time, even though other parts of the vehicle may be dry.

- High temperatures will cause corrosion to parts of the vehicle which cannot dry quickly due to lack of proper ventilation.

■ To help prevent corrosion

Wash the vehicle regularly to prevent corrosion of the body and suspension components. Also, wash the vehicle promptly after driving on any of the following surfaces.

- roads that have been salted to prevent them from freezing in winter
- mud, sand, or gravel
- coastal roads

After the winter has ended, it is recommended that the underbody be given a very thorough washing.

Before the beginning of winter, check the condition of underbody components, such as the exhaust system, fuel and brake lines, brake cables, suspension, steering system, floor pan, and fenders. If any of them are found to be rusted, they should be given an appropriate rust prevention treatment or should be replaced. Contact your SUBARU dealer to perform this kind of maintenance and treatment if you need

assistance.

Repair chips and scratches in the paint as soon as you find them.

Check the interior of the vehicle for water and dirt accumulation under the floor mats because that could cause corrosion. Occasionally check under the mats to make sure the area is dry.

Keep your garage dry. Do not park your vehicle in a damp, poorly ventilated garage. In such a garage, corrosion can be caused by dampness. If you wash the vehicle in the garage or put the vehicle into the garage when wet or covered with snow, that can cause dampness.

If your vehicle is operated in cold weather and/or in areas where road salts and other corrosive materials are used, the door hinges and locks, trunk lid lock, and hood latch should be inspected and lubricated periodically.

Cleaning the interior

Use a soft, damp cloth to clean the climate control panel, audio equipment, instrument panel, center console, combination meter panel, and switches. (Do not use organic solvents.)



CAUTION

Do not use sharp instruments or window cleaner containing abrasives to clean the inner surface of the rear window. They may damage the conductors printed on the window.

■ Seat fabric

Remove loose dirt, dust or debris with a vacuum cleaner. If the dirt is caked on the fabric or hard to remove with a vacuum cleaner, use a soft brush then vacuum it. Wipe the fabric surface with a tightly wrung cloth and dry the seat fabric thoroughly. If the fabric is still dirty, wipe using a solution of mild soap and lukewarm water then dry thoroughly.

If the stain does not come out, try a commercially-available fabric cleaner. Use the cleaner on a hidden place and make

sure it does not affect the fabric adversely. Use the cleaner according to its instructions.



CAUTION

When cleaning the seat, do not use benzine, paint thinner, or any similar materials. Doing so could damage the surface and cause the color to deteriorate.

■ **Leather seat materials**

The leather used by SUBARU is a high quality natural product which will retain its distinctive appearance and feel for many years with proper care.

Allowing dust or road dirt to build up on the surface can cause the material to become brittle and to wear prematurely. Regular cleaning with a soft, moist, natural fiber cloth should be performed monthly, taking care not to soak the leather or allow water to penetrate the stitched seams.

A mild detergent suitable for cleaning woolen fabrics may be used to remove difficult dirt spots, rubbing with a soft, dry cloth afterwards to restore the luster. If your SUBARU is to be parked for a long time in bright sunlight, it is recommended that the seats and head restraints be

covered, or the windows shaded, to prevent fading or shrinkage.

Minor surface blemishes or bald patches may be treated with a commercial leather spray lacquer. You will discover that each leather seat section will develop soft folds or wrinkles, which is characteristic of genuine leather.

■ **Synthetic leather upholstery**

The synthetic leather material used on the SUBARU may be cleaned using mild soap or detergent and water, after first vacuuming or brushing away loose dirt. Allow the soap to soak in for a few minutes and wipe off with a clean, damp cloth. Commercial foam-type cleaners suitable for synthetic leather materials may be used when necessary.



CAUTION

Strong cleaning agents such as solvents, paint thinners, window cleaner or fuel must never be used on leather or synthetic interior materials. Doing so could damage the surface and cause the color to deteriorate.

■ **Seatbelt**

For details about how to clean the seatbelt, refer to "Seatbelt maintenance" ¶ 1-20.

■ **Climate control panel, audio panel, instrument panel, console panel, and switches**

Use a soft, damp cloth to clean the climate control panel, audio equipment, instrument panel, center console, combination meter panel, and switches.



CAUTION

- **Do not use organic solvents such as paint thinners or fuel, or strong cleaning agents that contain those solvents. Doing so could damage the surface and cause the color to deteriorate.**
- **Do not use chemical solvents that contain silicone on the vehicle audio system, electrical components of the air-conditioner or any switches. If silicone adheres to these parts, it may cause damage to electrical components.**

■ Monitor

To clean the audio/navigation/multi function display monitor, wipe it with a silicone cloth or with a soft cloth. If the monitor is extremely dirty, clean it with a soft cloth moistened with neutral detergent then carefully wipe off any remaining detergent.



CAUTION

- Do not spray neutral detergent directly onto the monitor. Doing so could damage the monitor's components.
- Do not wipe the monitor with a hard cloth. Doing so could scratch the monitor.
- Do not use cleaning fluid that contains thinner, fuel, or any other volatile substance. Such cleaning fluid could erase the lettering on the switches at the bottom of the monitor.

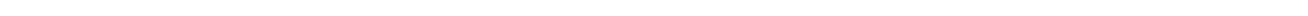
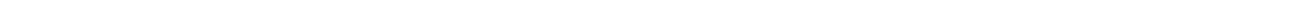
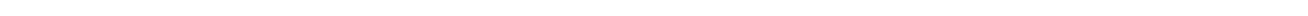
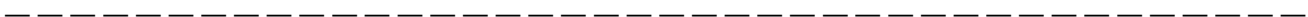
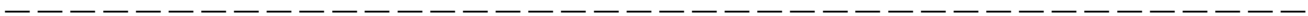
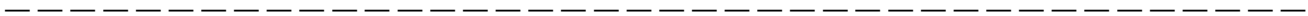

Maintenance schedule	11-3	Front differential gear oil (CVT models) and rear differential gear oil.....	11-15
Maintenance precautions.....	11-3	Recommended grade and viscosity.....	11-15
Before checking or servicing in the engine compartment.....	11-4	Brake fluid.....	11-15
When checking or servicing in the engine compartment.....	11-4	Checking the fluid level.....	11-15
When checking or servicing in the engine compartment while the engine is running.....	11-5	Recommended brake fluid	11-16
Engine hood	11-5	Clutch fluid (MT models).....	11-16
Engine compartment overview.....	11-7	Checking the fluid level.....	11-16
Engine oil.....	11-8	Recommended clutch fluid.....	11-17
Engine oil consumption.....	11-8	Brake booster	11-17
Locations of the oil level gauge, oil filler cap and oil filter	11-8	Brake pedal	11-18
Checking the oil level.....	11-8	Checking the brake pedal free play	11-18
Changing the oil and oil filter.....	11-9	Checking the brake pedal reserve distance.....	11-18
Recommended grade and viscosity	11-10	Clutch pedal (MT models)	11-18
Synthetic oil.....	11-10	Checking the clutch function.....	11-18
Cooling system	11-10	Checking the clutch pedal free play.....	11-19
Safety precautions	11-10	Hill start assist system.....	11-19
Cooling fan, hose and connections.....	11-11	Replacement of brake pad and lining	11-19
Engine coolant.....	11-11	Breaking-in of new brake pads and linings	11-20
Air cleaner element.....	11-12	Parking brake stroke	11-20
Replacing the air cleaner element	11-13	Tires and wheels.....	11-21
Spark plugs	11-14	Types of tires.....	11-21
Recommended spark plugs	11-14	Tire pressure monitoring system (TPMS) (if equipped)	11-21
Drive belts	11-14	Tire inspection.....	11-22
Manual transmission oil	11-14	Tire pressures and wear	11-23
Recommended grade and viscosity	11-14	Wheel balance	11-24
Continuously variable transmission fluid.....	11-15	Wear indicators	11-25
		Tire rotation direction mark.....	11-25
		Tire rotation.....	11-25

Tire replacement	11-26
Wheel replacement.....	11-27
Wheel covers (if equipped)	11-27
Aluminum wheels (if equipped)	11-28
Windshield washer fluid	11-29
Adding the windshield washer fluid	11-29
Windshield washer fluid	11-29
Replacement of wiper blades	11-30
Windshield wiper blade assembly	11-30
Window wiper blade rubber	11-31
Rear window wiper blade assembly	11-32
Rear window wiper blade rubber.....	11-33
Battery.....	11-34
Fuses	11-35
Installation of accessories.....	11-36
Replacing bulbs	11-37
Headlights (models with LED headlights)	11-37

Headlights (models with halogen headlights)	11-37
Front turn signal light	11-39
Parking light.....	11-39
Front fog light (if equipped).....	11-39
Rear combination lights	11-39
Backup light.....	11-41
License plate light	11-43
Map light	11-44
Vanity mirror light (if equipped).....	11-44
Dome light and cargo area light	11-44
Trunk light.....	11-44
Other bulbs	11-44
Replacing key battery.....	11-45
Safety precautions.....	11-45
Replacing battery of access key fob.....	11-45
Replacing transmitter battery	11-46

Maintenance schedule

U.S. models

The scheduled maintenance items required to be serviced at regular intervals are shown in the "Warranty and Maintenance Booklet". For details, read the separate "Warranty and Maintenance Booklet".

Canada models

The scheduled maintenance items required to be serviced at regular intervals are shown in the "Warranty and Service Booklet". For details, read the separate "Warranty and Service Booklet".

Except for U.S. and Canada models

Some items of your vehicle are required to be serviced at scheduled intervals. For details about your maintenance schedule, read the separate "Warranty and Maintenance Booklet".

NOTE

For models with a multi-function display (color LCD), you can set a reminder to be displayed when a scheduled maintenance item is almost due. For details, refer to "Maintenance settings" ☞ 3-62.

Maintenance precautions

When maintenance and service are required, it is recommended that all work be done by an authorized SUBARU dealer.

If you perform maintenance and service by yourself, you should familiarize yourself with the information provided in this section on general maintenance and service for your SUBARU.

Incorrect or incomplete service could cause improper or unsafe vehicle operation. Any problems caused by improper maintenance and service performed by you are not eligible for warranty coverage.



WARNING

- Always select a safe area when performing maintenance on your vehicle.
- Always be very careful to avoid injury when working on the vehicle. Remember that some of the materials in the vehicle may be hazardous if improperly used or handled, for example, battery acid.
- Your vehicle should only be serviced by persons fully competent to do so. Serious personal injury

may result to persons not experienced in servicing vehicles.

- Always use the proper tools and make certain that they are well maintained.
- Never get under the vehicle supported only by a jack. Always use safety stands to support the vehicle.
- Never keep the engine running in a poorly ventilated area, such as a garage or other closed areas.
- Do not smoke or allow open flames around the fuel or battery. This will cause a fire.
- Because the fuel system is under pressure, replacement of the fuel filter should be performed only by your SUBARU dealer.
- Wear adequate eye protection to guard against getting oil or fluids in your eyes. If something does get in your eyes, thoroughly wash them out with clean water.
- Do not tamper with the wiring of the SRS airbag system or seat-belt pretensioner system, or attempt to take its connectors apart, as that may activate the system or it can render it inop-

erative. NEVER use a circuit tester for this wiring. If your SRS airbag or seatbelt pretensioner needs service, consult your nearest SUBARU dealer.

NOTE

SUBARU does not endorse the use of non-SUBARU approved flushing systems and strongly advises against performing these services on a SUBARU vehicle. Non-SUBARU approved flushing systems use chemicals and/or solvents which have not been tested or approved by SUBARU. SUBARU warranties do not cover any part of the vehicle which is damaged by adding or applying chemicals and/or solvents other than those approved or recommended by SUBARU.

■ Before checking or servicing in the engine compartment

WARNING

- Always stop the engine and apply the parking brake firmly to prevent the vehicle from moving.
- Always let the engine cool down. Engine parts become very hot

when the engine is running and remain hot for some time after the engine has stopped.

- Do not spill engine oil, engine coolant, brake fluid or any other fluid on hot engine components. This may cause a fire.
- When the ignition switch is in the "ON" position, the cooling fan may operate suddenly even when the engine is stopped. If your body or clothes come into contact with a rotating fan, that could result in serious injury. To avoid risk of injury, perform the following precautions.
 - Models with push-button start system:
Always turn the push-button ignition switch to the "OFF" position and confirm that the operation indicator on the switch is turned off. Then take the access key fob out from the vehicle.
 - Models without push-button start system:
Always remove the key from the ignition switch.
- Before performing any servicing on a vehicle equipped with a

remote engine start system (a dealer option), temporarily place the remote engine start system in service mode to prevent it from unexpectedly starting the engine.

■ When checking or servicing in the engine compartment

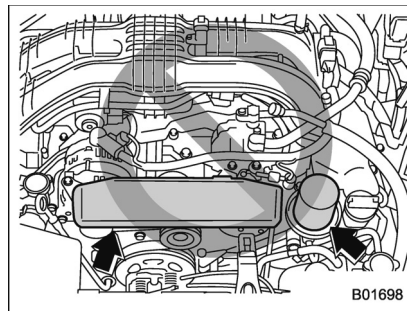

CAUTION

- Do not contact the drive belt cover while checking the components in the engine compartment. Doing so may cause your hand to slip off the cover and result in an unexpected injury.
- Do not touch the oil filter until the

engine has cooled down completely. Doing so may result in a burn or other injury. Note that the oil filter becomes very hot when the engine is running and remains hot for some time after the engine has stopped.

■ **When checking or servicing in the engine compartment while the engine is running**

WARNING

A running engine can be dangerous. Keep your fingers, hands, clothing, hair and tools away from the cooling fan, drive belt and any other moving engine parts. Removing rings, watches and ties is advisable.

Engine hood

CAUTION

- When you open the engine hood, do not stand the wiper blades up. Furthermore, while the hood is open, do not operate the windshield wipers. Doing so could result in damage to the engine hood and wiper blades.
- Be extremely careful not to catch fingers or other objects when closing the engine hood.
- Do not push the hood forcibly to close it. It could deform the metal.
- Be extremely careful opening the engine hood when the wind is strong. The engine hood could close suddenly, possibly causing injuries from slamming.
- Do not install accessories other than genuine SUBARU parts to the engine hood. If the engine hood becomes too heavy, the stay may not be able to support holding it open.

To open the hood:

1. If the wiper blades are lifted off the windshield, return them to their original position.

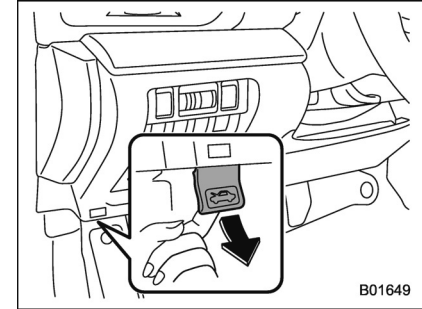

2. Pull the hood release knob under the instrument panel.

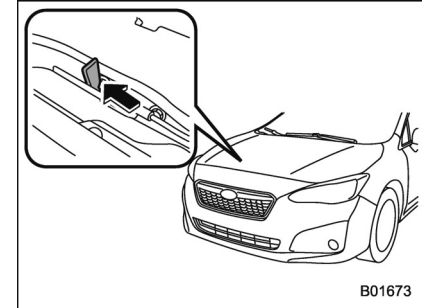

3. Release the secondary hood release by moving the lever between the front grille and the hood toward the left.

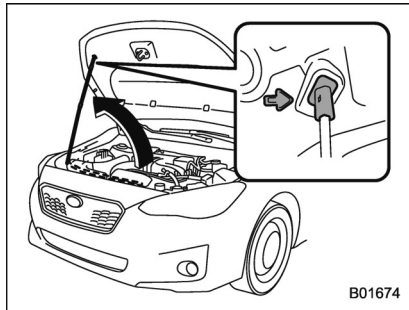

4. Lift up the hood, release the hood prop from its retainer and put the end of the hood prop into the slot in the hood.

To close the hood:

1. Lift the hood slightly and remove the hood prop from the slot in the hood and return the prop to its retainer.
2. Lower the hood to a height of approximately 5.9 in (15 cm) above its closed position and then let it drop.
3. After closing the hood, be sure the hood is securely locked.

If this does not close the hood, release it from a slightly higher position.



WARNING

Always check that the hood is properly locked before you start driving. If it is not, it might fly open while the vehicle is moving and block your view, which may cause an accident and serious bodily injury.

Engine compartment overview

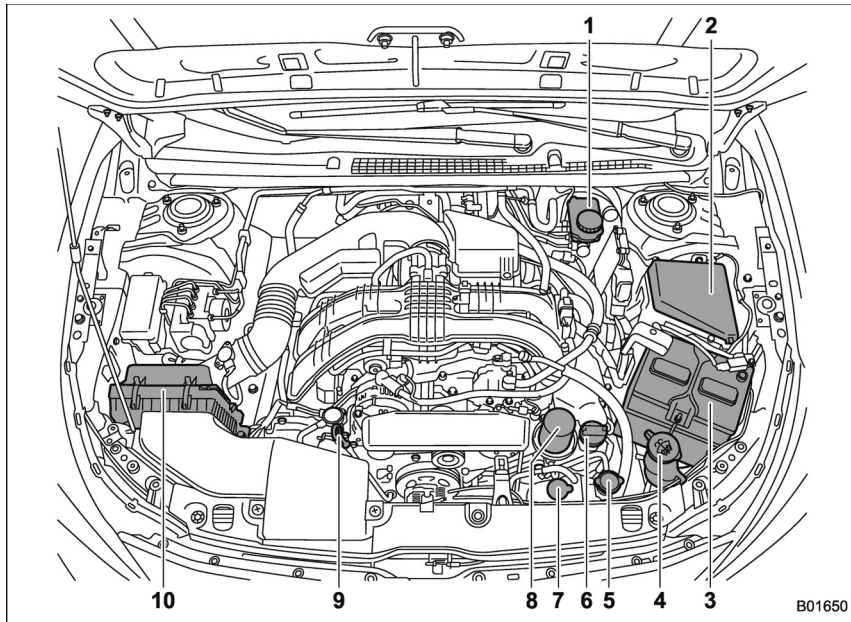

- 1) Brake fluid reservoir/Clutch fluid reservoir (MT models) (page 11-15)
- 2) Fuse box (page 11-35)
- 3) Battery (page 11-34)
- 4) Windshield washer tank (page 11-29)
- 5) Radiator cap (page 11-11)
- 6) Engine oil filler cap (page 11-8)
- 7) Engine coolant reservoir (page 11-11)
- 8) Engine oil filter (page 11-9)
- 9) Engine oil level gauge (page 11-8)
- 10) Air cleaner case (page 11-12)

B01650

Engine oil

CAUTION

- If the level gauge cannot be pulled out easily, twist the level gauge right and left, then gently pull it out. Otherwise, you may be injured accidentally straining yourself.
- Use only engine oil with the recommended grade and viscosity.
- Be careful not to spill engine oil when adding it. If oil touches the exhaust pipe, it may cause a bad smell, smoke, and/or a fire. If engine oil gets on the exhaust pipe, be sure to wipe it off.

■ Engine oil consumption

Some engine oil will be consumed while driving. The rate of consumption can be affected by such factors as transmission type, driving style, terrain and temperature. Under the following conditions, oil consumption can be increased and thus require refilling between maintenance intervals:

- When the engine is new and within the

break-in period

- When the engine oil is of lower quality
- When the incorrect oil viscosity is used
- When engine braking is employed (repeatedly)
- When the engine is operated at high engine speeds (for extended periods of time)
- When the engine is operated under heavy loads (for extended periods of time)
- When the engine idles for extended periods of time
- When the vehicle is operated in stop and go and/or heavy traffic situations
- When the vehicle is used under severe thermal conditions
- When the vehicle accelerates and decelerates frequently

Under these or similar conditions, you should check your oil at least every 2nd fuel fill-up and change your engine oil more frequently. Different drivers in the same car may experience different results. If your oil consumption rate is greater than expected, contact your authorized SUBARU retailer who may perform a test under controlled conditions.

■ Locations of the oil level gauge, oil filler cap and oil filter

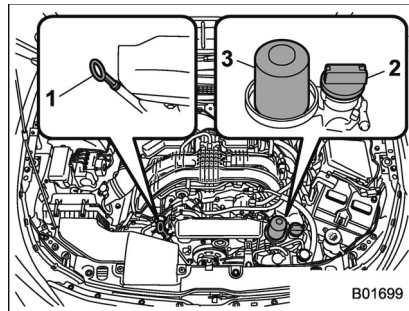

- 1) Oil level gauge
- 2) Oil filler cap
- 3) Oil filter

■ Checking the oil level

1. Park the vehicle on a level surface and turn the ignition switch to the "LOCK"/"OFF" position. If you check the oil level just after turning the ignition switch to the "LOCK"/"OFF" position, wait a few minutes for the oil to drain back into the oil pan before checking the level.

CAUTION

If the level gauge cannot be pulled out easily, twist the level gauge right and left, then gently pull it out. Otherwise, you may be injured accidentally straining yourself.

2. Pull out the level gauge, wipe it clean, and insert it again.
3. Be sure the level gauge is correctly inserted until it stops.

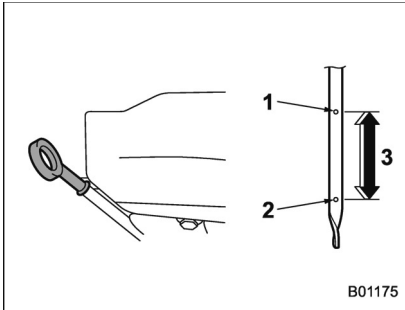

- 1) Full level
 - 2) Low level
 - 3) Approximately 1.1 US qt (1.0 liter, 0.9 Imp qt) from low level to full level
4. Pull out the oil level gauge again.
 5. Check the oil levels on both sides of the level gauge. The engine oil level must

be judged by the lowest of the two levels. If the oil level is below the low level mark, add oil so that the full level is reached.

CAUTION

- Be careful not to touch the engine oil filter when removing the oil filler cap. Doing so may result in a burn, a pinched finger, or may cause some other injury.
- Use only engine oil with the recommended grade and viscosity.
- Be careful not to spill engine oil when adding it. If oil touches the exhaust pipe, it may cause a bad smell, smoke, and/or a fire. If engine oil gets on the exhaust pipe, be sure to wipe it off.

To add engine oil, remove the engine oil filler cap and slowly pour engine oil through the filler neck. After pouring oil into the engine, you must use the level gauge to confirm that the oil level is correct.

NOTE

- To prevent overfilling the engine oil, do not add any additional oil above the upper level when the engine is cold.

- The engine low oil level warning light may stay illuminated when the engine is started straight after topping up or changing the engine oil. In such cases, park the vehicle on a level surface and wait for more than a minute until the oil level settles, after which the warning light will turn off. Refer to "Engine low oil level warning light" 3-18.

Changing the oil and oil filter

Change the oil and oil filter according to the maintenance schedule in the "Warranty and Maintenance Booklet".

The engine oil and oil filter must be changed more frequently than listed in the maintenance schedule when driving on dusty roads, when short trips are frequently made, or when driving in extremely cold weather.

NOTE

- Changing the engine oil and oil filter should be performed by a well-trained expert. Contact your SUBARU dealer for changing the engine oil and oil filter. Fully trained mechanics are on standby at a SUBARU dealer to utilize the special tools, spare parts and recommended oil for this work, and also, used oils are properly disposed of.

- If performing oil replacement yourself, observe the local regulations and dispose of waste oil properly.

■ Recommended grade and viscosity



Use only engine oil with the recommended grade and viscosity.

Refer to "Engine oil" 12-4.

NOTE

Engine oil viscosity (thickness) affects fuel economy. Oils of lower viscosity provide better fuel economy. However, in hot weather, oil of higher viscosity is required to properly lubricate the engine.

■ Synthetic oil

You should use synthetic engine oil that meets the same requirements given for conventional engine oil. When using synthetic oil, you must use oil of the same classification, viscosity and grade shown in this Owner's Manual. Refer to "Engine oil" 12-4. Also, you must follow the oil and filter changing intervals shown in the

Warranty and Maintenance booklet.

NOTE

Synthetic oil of the grade and viscosity noted in chapter 12 is the recommended engine oil for optimum engine performance. Conventional oil may be used if synthetic oil is unavailable.

Cooling system

■ Safety precautions



Never attempt to remove the radiator cap until the engine has been shut off and has cooled down completely. Since the coolant is under pressure, you may suffer serious burns from a spray of boiling hot coolant when the cap is removed.



- Vehicles are filled at the factory with SUBARU Super Coolant that does not require the first change for 11 years/137,500 miles (11 years/220,000 km). This coolant should not be mixed with any other brand or type of coolant during this period. Mixing with a different coolant will reduce the life of the coolant. Should it be necessary to top up the coolant for any reason, use only SUBARU Super Coolant.

If the SUBARU Super Coolant is

diluted with another brand or type, the maintenance interval is shortened to that of the mixing coolant.

- **Do not splash the engine coolant over painted parts. The alcohol contained in the engine coolant may damage the paint surface.**

■ Cooling fan, hose and connections

Your vehicle employs an electric cooling fan which is thermostatically controlled to operate when the engine coolant reaches a specific temperature.

If the radiator cooling fan does not operate even when the coolant temperature high warning light blinks or illuminates in **RED**, the cooling fan circuit may be defective. Refer to "Coolant temperature low indicator light/Coolant temperature high warning light" 3-17.

Check the fuse and replace it if necessary. Refer to "Fuses" 11-35 and "Fuse panel located in the engine compartment" 12-12.

If the fuse is not blown, have the cooling system checked by your SUBARU dealer.

If frequent addition of coolant is neces-

sary, there may be a leak in the engine cooling system. It is recommended that the cooling system and connections be checked for leaks, damage, or looseness.

■ Engine coolant

▼ Checking the coolant level

WARNING

Never attempt to remove the radiator cap until the engine has been shut off and has cooled down completely. Since the coolant is under pressure, you may suffer serious burns from a spray of boiling hot coolant when the cap is removed.

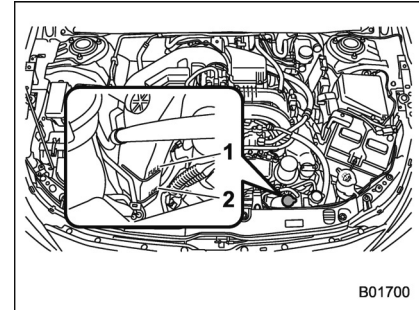

- 1) "FULL" level mark
- 2) "LOW" level mark

Check the coolant level at each fuel stop.

1. Check the coolant level on the outside of the reservoir while the engine is cool.

2. If the level is close to or lower than the "LOW" level mark, add coolant up to the "FULL" level mark. If the reserve tank is empty, remove the radiator cap and refill coolant up to just below the filler neck as shown in the following illustration.

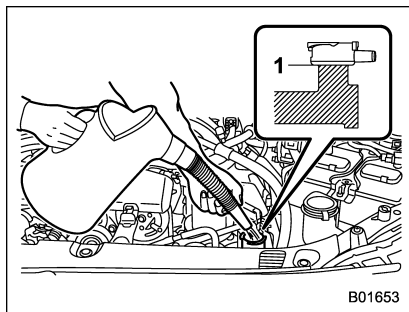

1) Fill up to this level

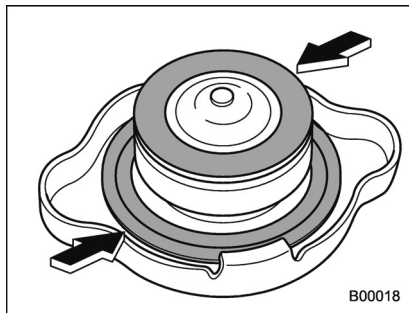

3. After refilling the reserve tank and the radiator, reinstall the cap and check that the rubber gaskets inside the radiator cap are in the proper position.

CAUTION

- Be careful not to spill engine coolant when adding it. If coolant touches the exhaust pipe, it may cause a bad smell, smoke, and/or a fire. If engine coolant gets on the exhaust pipe, be sure to wipe it off.
- Do not splash the engine coolant over painted parts. The alcohol contained in the engine coolant may damage the paint surface.

▼ Changing the coolant

It may be difficult to change the coolant. Have the coolant changed by your SUBARU dealer if necessary.

The coolant should be changed according to the maintenance schedule in the "Warranty and Maintenance Booklet".

Air cleaner element

WARNING

Do not operate the engine with the air cleaner element removed. The air cleaner element not only filters intake air but also stops flames if the engine backfires. If the air cleaner element is not installed when the engine backfires, you could be burned.

CAUTION

When replacing the air cleaner element, use a genuine SUBARU air cleaner element. If it is not used, there is the possibility of causing a negative effect to the engine.

The air cleaner element functions as a filter screen. When the element is perforated or removed, engine wear will be excessive and engine life shortened.

It is not necessary to clean or wash the air cleaner element.

■ Replacing the air cleaner element

Replace the air cleaner element according to the maintenance schedule in the "Warranty and Maintenance Booklet". Under extremely dusty conditions, replace it more frequently. It is recommended that you always use genuine SUBARU parts.

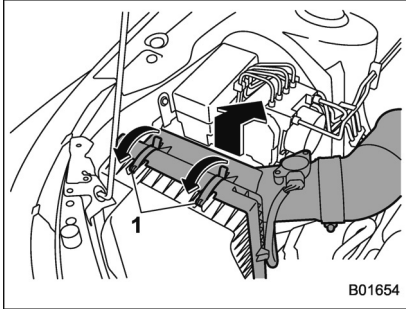

1) Clip

1. Unsnap the two clips holding the air cleaner case (rear).
2. Open the air cleaner case and pull the cover rearward while lifting it up.

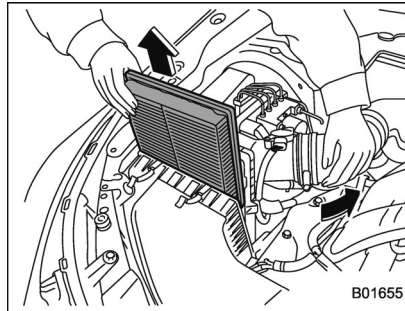

3. Remove the air cleaner element.
4. Clean the inside of the air cleaner case (both front and rear) with a damp cloth and install a new air cleaner element.

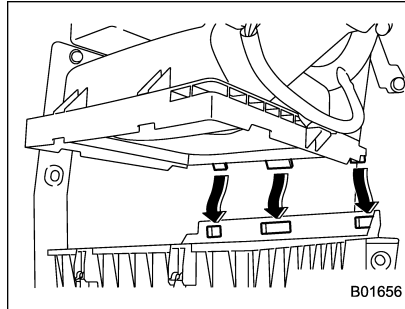

5. To install the air cleaner case (rear), insert the three projections on the air

cleaner case (rear) into the slits on the air cleaner case (front).

6. Install in the reverse order of removal.

NOTE

Install the air cleaner element so that the surface with "UPR" printed on it faces upward.

Spark plugs

It may be difficult to replace the spark plugs. It is recommended that you have the spark plugs replaced by your SUBARU dealer.

The spark plugs should be replaced according to the maintenance schedule in the "Warranty and Maintenance Booklet".



CAUTION

Make sure the cables are replaced in the correct order.

■ Recommended spark plugs

For the recommended spark plugs, refer to "Electrical system" 12-8.

Drive belts

It is unnecessary to check the deflection of the drive belt periodically because your engine is equipped with an automatic belt tension adjuster. However, replacement of the belt should be done according to the maintenance schedule in the "Warranty and Maintenance Booklet". Consult your SUBARU dealer for replacement.

If the drive belt is loose, cracked or worn, contact your SUBARU dealer.

Manual transmission oil

It is not necessary to check the transmission oil level. Check that there are no cracks, damage or leakage. However, the oil inspection should be performed according to the maintenance schedule in the "Warranty and Maintenance Booklet". Consult your SUBARU dealer for details.

■ Recommended grade and viscosity

Each oil manufacturer has its own base oils and additives. Never use different brands together. For details, refer to "Manual transmission, front differential and rear differential gear oil" 12-6.

Continuously variable transmission fluid

It is not necessary to check the transmission fluid level. Check that there are no cracks, damage or leakage. However, the fluid inspection should be performed according to the maintenance schedule in the "Warranty and Maintenance Booklet". Consult your SUBARU dealer for details.

Front differential gear oil (CVT models) and rear differential gear oil

It is not necessary to check the gear oil level. Check that there are no cracks, damage or leakage. However, the oil inspection should be performed according to the maintenance schedule in the "Warranty and Maintenance Booklet". Consult your SUBARU dealer for details.

■ Recommended grade and viscosity

Each oil manufacturer has its own base oils and additives. Never use different brands together. For details, refer to "Manual transmission, front differential and rear differential gear oil" ^① 12-6.



CAUTION

Using a differential gear oil other than the specified oil may cause a decline in vehicle performance.

Brake fluid

■ Checking the fluid level



WARNING

- Never let brake fluid contact your eyes because brake fluid can be harmful to your eyes. If brake fluid gets in your eyes, immediately flush them thoroughly with clean water. For safety, when performing this work, wearing eye protection is advisable.
- Brake fluid absorbs moisture from the air. Any absorbed moisture can cause a dangerous loss of braking performance.
- If the vehicle requires frequent refilling, there may be a leak. If you suspect a problem, have the vehicle checked at your SUBARU dealer.



CAUTION

- When adding brake fluid, be careful not to allow any dirt into the reservoir.
- Never splash the brake fluid over painted surfaces or rubber parts.

Alcohol contained in the brake fluid may damage them.

- Be careful not to spill brake fluid when adding it. If brake fluid touches the exhaust pipe, it may cause a bad smell, smoke, and/or a fire. If brake fluid gets on the exhaust pipe, be sure to wipe it off.

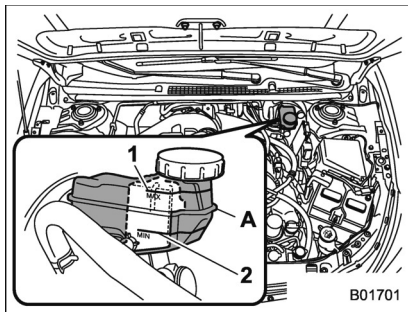

- 1) "MAX" level line
 - 2) "MIN" level line
- A) The brake fluid level must be checked in this area.

Check the fluid level monthly.

Check the fluid level on the outside of the reservoir. Be sure to check the fluid level for the brake system at the **shaded area in the illustration**. For MT models, this

reservoir is used for both the brake and clutch systems and has chambers for each system.

If the fluid level is below "MIN", add the recommended brake fluid to "MAX". Use only brake fluid from a sealed container.

■ Recommended brake fluid

Refer to "Fluids" 12-7.

▲ CAUTION

Never use different brands of brake fluid together. Also, avoid mixing DOT 3 and DOT 4 brake fluids even if they are the same brand.

Clutch fluid (MT models)

■ Checking the fluid level

▲ WARNING

Never let clutch fluid contact your eyes because clutch fluid can be harmful to your eyes. If clutch fluid gets in your eyes, immediately flush them thoroughly with clean water. For safety, when performing this work, wearing eye protection is advisable.

▲ CAUTION

- Clutch fluid absorbs moisture from the air. Any absorbed moisture can cause improper clutch operation.
- If the vehicle requires frequent refilling, there may be a leak. If you suspect a problem, have the vehicle checked at your SUBARU dealer.
- When clutch fluid is added, be careful not to allow any dirt into the tank.
- Never splash the clutch fluid over painted surfaces or rubber parts.

Alcohol contained in the clutch fluid may damage them.

- Be careful not to spill clutch fluid when adding it. If clutch fluid touches the exhaust pipe, it may cause a bad smell, smoke, and/or a fire. If clutch fluid gets on the exhaust pipe, be sure to wipe it off.
- The fluid level for the clutch system must be checked at the inboard side of the reservoir. It cannot be checked at the outboard side of the reservoir.

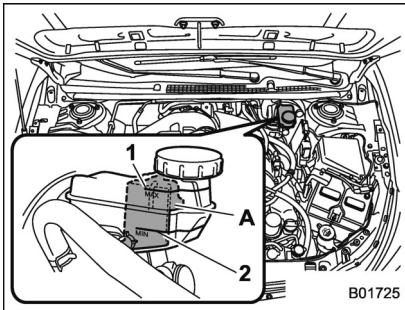

- 1) "MAX" level line
 - 2) "MIN" level line
- A) The clutch fluid level must be checked in this area.

Check the fluid level monthly.

Check the fluid level on the outside of the reservoir. Because this reservoir is used for both the brake and clutch systems and has chambers for each system, be sure to check the fluid level for the clutch system at the **shaded area in the illustration**. If the fluid level is below "MIN", add the recommended clutch fluid to "MAX".

Use only clutch fluid from a sealed container.

■ Recommended clutch fluid

Refer to "Fluids" 12-7.



Never use different brands of clutch fluid together. Also, avoid mixing DOT 3 and DOT 4 brake fluids even if they are the same brand.

Brake booster

If the brake booster does not operate as described in the following, have it checked by your SUBARU dealer.

1. With the ignition switch in the "LOCK"/"OFF" position, depress the brake pedal several times, applying the same pedal force each time. The distance the pedal travels should not vary.
2. With the brake pedal depressed, start the engine. The pedal should move slightly down to the floor.
3. With the brake pedal depressed, stop the engine and keep the pedal depressed for 30 seconds. The pedal height should not change.
4. Start the engine again and run for approximately one minute then turn it off. Depress the brake pedal several times to check the brake booster. The brake booster operates properly if the pedal stroke decreases with each depression.

Brake pedal

Check the brake pedal free play and reserve distance according to the maintenance schedule in the "Warranty and Maintenance Booklet".

■ Checking the brake pedal free play

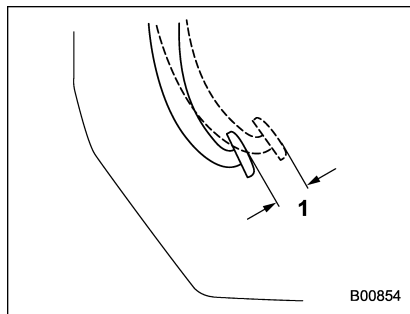

- 1) 0.02 – 0.11 in (0.5 – 2.7 mm)

Turn the ignition switch to the "LOCK"/"OFF" position and firmly depress the brake pedal several times. Lightly pull the brake pedal up with one finger to check the free play with a force of less than 2 lbf (10 N, 1 kgf).

If the free play is not within proper specification, contact your SUBARU deal-

er.

■ Checking the brake pedal reserve distance

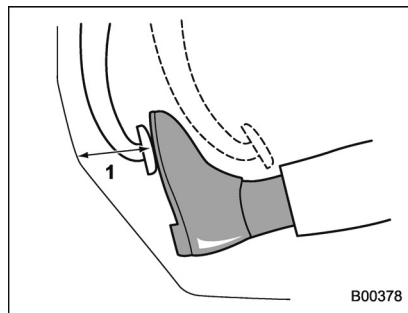

- 1) More than 2.56 in (65 mm)

Depress the pedal with a force of approximately 66 lbf (294 N, 30 kgf) and measure the distance between the upper surface of the pedal pad and the floor.

When the measurement is smaller than the specification, or when the pedal does not operate smoothly, contact with your SUBARU dealer.

Clutch pedal (MT models)

Check the clutch pedal free play according to the maintenance schedule in the "Warranty and Maintenance Booklet".

■ Checking the clutch function

Check the clutch engagement and disengagement.

1. With the engine idling, check that there are no abnormal noises when the clutch pedal is depressed, and that shifting into 1st or reverse feels smooth.
2. Start the vehicle by releasing the pedal slowly to check that the engine and transmission smoothly couple without any sign of slippage.

■ Checking the clutch pedal free play

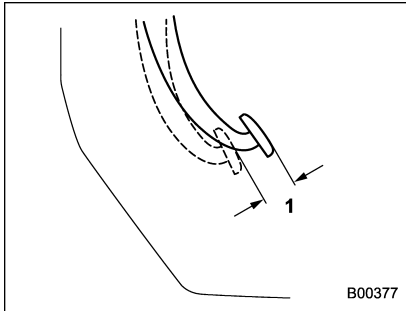

1) 0.16 – 0.43 in (4.0 – 11.0 mm)

Lightly depress the clutch pedal down with your finger until you feel resistance, and check the free play.

If the free play is not within proper specification, contact your SUBARU dealer.

Hill start assist system

Ensure that the Hill start assist system operates properly under the following circumstances.

1. Stop the vehicle on an uphill grade by depressing the brake pedal (all models) and clutch pedal (MT models only), with the engine running.
2. Make sure that the vehicle does not move backward for several seconds after the brake pedal is released.
3. Then make sure the vehicle starts climbing the grade by following the normal starting procedures.

If the Hill start assist system does not operate as described above, contact your SUBARU dealer.

Replacement of brake pad and lining

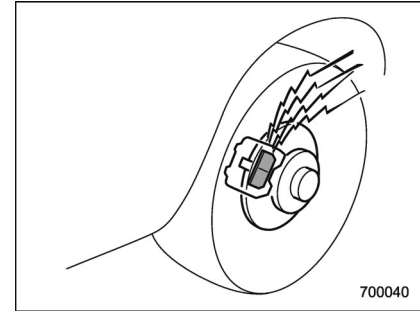

The disc brakes have audible wear indicators on the brake pads. If the brake pads wear close to their service limit, the wear indicator makes a very audible scraping noise when the brake pedal is applied.

If you hear this scraping noise each time you apply the brake pedal, have the brake pads serviced by your SUBARU dealer as soon as possible.



CAUTION

If you continue to drive despite the scraping noise from the audible

brake pad wear indicator, it will result in the need for costly brake rotor repair or replacement.

■ Breaking-in of new brake pads and linings

When replacing the brake pad or lining, use only genuine SUBARU parts. After replacement, the new parts must be broken in as follows.

▼ Brake pad and lining

While maintaining a speed of 30 to 40 mph (50 to 65 km/h), step on the brake pedal lightly. Repeat this five or more times.

▼ Parking brake lining

1. Drive the vehicle at a speed of approximately 22 mph (35 km/h).
2. With the parking brake release button pushed in, pull the parking brake lever SLOWLY and GENTLY (pulling with a force of approximately 33.7 lbf [150 N, 15.3 kgf]).
3. Drive the vehicle for approximately 220 yards (200 meters) in this condition.
4. Wait 5 to 10 minutes for the parking brake to cool down. Repeat this procedure.
5. Check the parking brake stroke. If the

parking brake stroke is out of the specified range, adjust it by turning the adjusting nut located on the parking brake lever.

Parking brake stroke:

7 – 8 notches / 45 lbf (200 N, 20.4 kgf)



WARNING

A safe location and situation should be selected for break-in driving.



CAUTION

Pulling the parking brake lever too forcefully may cause the rear wheels to lock. To avoid this, be certain to pull the lever up slowly and gently.

Parking brake stroke

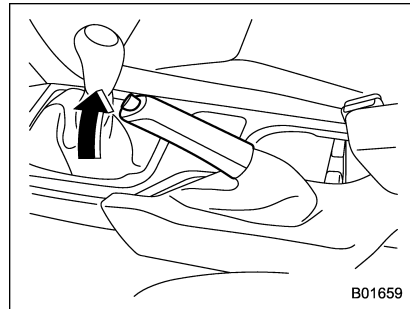

Check the parking brake stroke according to the maintenance schedule in the “Warranty and Maintenance Booklet”. When the parking brake is properly adjusted, braking power is fully applied by pulling the lever up 7 to 8 notches gently but firmly (approximately 45 lbf [200 N, 20.4 kgf]). If the parking brake lever stroke is not within the specified range, have the brake system checked and adjusted at your SUBARU dealer.

Tires and wheels

■ Types of tires

You should be familiar with type of tires present on your vehicle.

▼ All season tires

All season tires are designed to provide an adequate measure of traction, handling and braking performance in year-round driving including snowy and icy road conditions. However all season tires do not offer as much traction performance as winter (snow) tires in heavy or loose snow or on icy roads.

All season tires are identified by "ALL SEASON" and/or "M+S" (Mud & Snow) on the tire sidewall.

▼ Summer tires

Summer tires are high-speed capability tires best suited for highway driving under dry conditions.

Summer tires are inadequate for driving on slippery roads such as on snow-covered or icy roads.

If you drive your vehicle on snow-covered or icy roads, we strongly recommend the use of winter (snow) tires.

When installing winter tires, be sure to replace all four tires.

▼ Winter (snow) tires

Winter tires are best suited for driving on snow-covered and icy roads. However winter tires do not perform as well as summer tires and all season tires on roads other than snow-covered and icy roads.

■ Tire pressure monitoring system (TPMS) (if equipped)

The tire pressure monitoring system provides the driver with a warning message by sending a signal from a sensor that is installed in each wheel when tire pressure is severely low. The tire pressure monitoring system will activate only when the vehicle is driven. Also, this system may not react immediately to a sudden drop in tire pressure (for example, a blow-out caused by running over a sharp object).

If you adjust the tire pressures in a warm garage and will then drive the vehicle in cold outside air, the resulting drop in tire pressures may cause the low tire pressure warning light to illuminate. To avoid this problem when adjusting the tire pressures in a warm garage, inflate the tires to pressures higher than those shown on the tire placard. Specifically, inflate them by an extra 1 psi (6.9 kPa, 0.07 kgf/cm²) for every difference of 10°F (5.6°C) between the temperature in the garage and the

temperature outside. By way of example, the following table shows the required tire pressures that correspond to various outside temperatures when the temperature in the garage is 60°F (15.6°C).

Example:

Tire size: P205/55R16 89V, 205/50R17 89V and P225/40R18 88V

Standard tire pressures:

Front: 33 psi (230 kPa, 2.3 kgf/cm²)

Rear: 32 psi (220 kPa, 2.2 kgf/cm²)

Garage temperature: 60°F (15.6°C)

Outside temperature	Adjusted pressure [psi (kPa, kgf/cm ²)]	
	Front	Rear
30°F (-1°C)	36 (250, 2.5)	35 (240, 2.4)
10°F (-12°C)	38 (265, 2.65)	37 (255, 2.55)
-10°F (-23°C)	40 (280, 2.8)	39 (270, 2.7)

If the low tire pressure warning light illuminates when you drive the vehicle in cold outside air after adjusting the tire pressures in a warm garage, re-adjust the tire pressures using the method described above. Then, increase the vehicle speed to at least 20 mph (32 km/h) and check to see that the low tire pressure warning light turns off a few minutes later. If the low tire pressure warning light does not turn off,

the tire pressure monitoring system may not be functioning normally. In this event, go to a SUBARU dealer to have the system inspected as soon as possible.

While the vehicle is driven, friction between tires and the road surface causes the tires to warm up. After illumination of the low tire pressure warning light, any increase in the tire pressures caused by an increase in the outside air temperature or by an increase in the temperature in the tires can cause the low tire pressure warning light to turn off.

System resetting is necessary when the wheels are changed (for example, a switch to snow tires) and new TPMS valves are installed on the newly fitted wheels. Have this work performed by a SUBARU dealer following wheel replacement.

It may not be possible to install TPMS valves on certain wheels that are on the market. Therefore, if you change the wheels (for example, a switch to snow tires), use wheels that have the same part number as the standard-equipment wheels. Without four operational TPMS valve/sensors on the wheels, the TPMS will not fully function and the warning light on the combination meter will illuminate steadily after blinking for approximately

one minute.

When a tire is replaced, adjustments are necessary to ensure continued normal operation of the tire pressure monitoring system. As with wheel replacement, therefore, you should have the work performed by a SUBARU dealer.

**WARNING**

If the low tire pressure warning light does not illuminate briefly after the ignition switch is turned ON or the light illuminates steadily after blinking for approximately one minute, you should have your Tire Pressure Monitoring System checked at a SUBARU dealer as soon as possible.

If this light illuminates while driving, never brake suddenly and keep driving straight ahead while gradually reducing speed. Then slowly pull off the road to a safe place. Otherwise an accident involving serious vehicle damage and serious personal injury could occur.

If this light still illuminates while driving after adjusting the tire pressure, a tire may have significant damage and a fast leak that causes the tire to lose air rapidly. If you have

a flat tire, replace it with a spare tire as soon as possible.

When a spare tire is mounted or a wheel rim is replaced without the original pressure sensor/transmitter being transferred, the low tire pressure warning light will illuminate steadily after blinking for approximately one minute. This indicates the TPMS is unable to monitor all four road wheels. Contact your SUBARU dealer as soon as possible for tire and sensor replacement and/or system resetting. If the light illuminates steadily after blinking for approximately one minute, promptly contact a SUBARU dealer to have the system inspected.

■ Tire inspection

Check on a daily basis that the tires are free from serious damage, nails, and stones. At the same time, check the tires for abnormal wear.

Contact your SUBARU dealer immediately if you find any problem.

NOTE

- **When the wheels and tires strike curbs or are subjected to harsh treatment as when the vehicle is driven on a**

rough surface, they can suffer damage that cannot be seen with the naked eye. This type of damage does not become evident until time has passed. Try not to drive over curbs, potholes or on other rough surfaces. If doing so is unavoidable, keep the vehicle's speed down to a walking pace or less, and approach the curbs as squarely as possible. Also, make sure the tires are not pressed against the curb when you park the vehicle.

- If you feel unusual vibration while driving or find it difficult to steer the vehicle in a straight line, one of the tires and/or wheels may be damaged. Drive slowly to the nearest authorized SUBARU dealer and have the vehicle inspected.

■ Tire pressures and wear

Maintaining the correct tire pressures helps to maximize the tires' service lives and is essential for good running performance. Check and, if necessary, adjust the pressure of each tire (including the spare - if equipped) at least once a month (for example, during a fuel stop) and before any long journey.

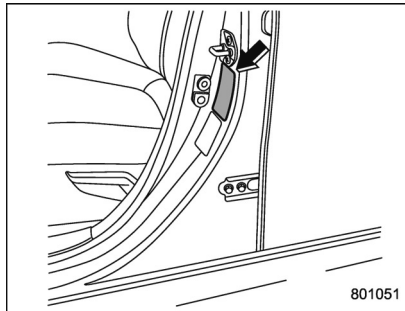

Tire placard

Check the tire pressures when the tires are cold. Use a pressure gauge to adjust the tire pressures to the values shown on the tire placard. The tire placard is located on the door pillar on the driver's side.

Driving even a short distance warms up the tires and increases the tire pressures. Also, the tire pressures are affected by the outside temperature. It is best to check tire pressure outdoors before driving the vehicle.

When a tire becomes warm, the air inside it expands, causing the tire pressure to increase. Be careful not to mistakenly release air from a warm tire to reduce its pressure.

NOTE

- The air pressure in a tire increases by approximately 4.3 psi (30 kPa, 0.3 kgf/cm²) when the tire becomes warm.
- The tires are considered cold when the vehicle has been parked for at least three hours or has been driven less than one mile (1.6 km).



WARNING

Do not let air out of warm tires to adjust pressure. Doing so will result in low tire pressure.

Incorrect tire pressures detract from controllability and ride comfort, and they cause the tires to wear abnormally.

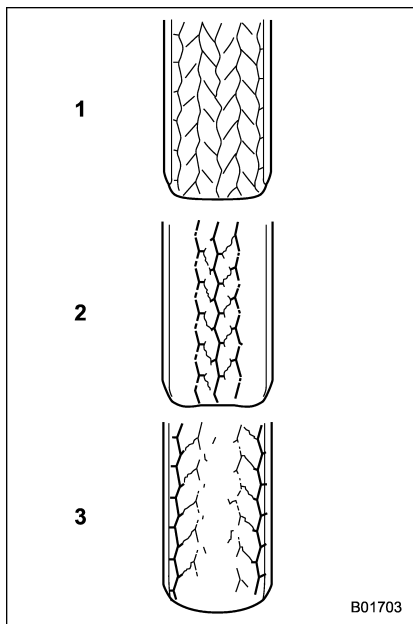

- 1) Correct tire pressure (tread worn evenly)
Roadholding is good, and steering is responsive. Rolling resistance is low, so fuel consumption is also lower.
- 2) Abnormally low tire pressure (tread worn at shoulders)
Rolling resistance is high, so fuel consumption is also higher.

- 3) Abnormally high tire pressure (tread worn in center)
Ride comfort is poor. Also, the tire magnifies the effects of road-surface bumps and dips, possibly resulting in vehicle damage.

If the tire placard shows tire pressures for the vehicle when fully loaded, adjust the tire pressures to the values that match current loading conditions.

WARNING

Driving at high speeds with excessively low tire pressures can cause the tires to deform severely and to rapidly become hot. A sharp increase in temperature could cause tread separation, and destruction of the tires. The resulting loss of vehicle control could lead to an accident.

Wheel balance

Each wheel was correctly balanced when your vehicle was new, but the wheels will become unbalanced as the tires become worn during use. Wheel imbalance causes the steering wheel to vibrate slightly at certain vehicle speeds and detracts from the vehicle's straight-line stability. It can also cause steering and suspension sys-

tem problems and abnormal tire wear. If you suspect that the wheels are not correctly balanced, have them checked and adjusted by your SUBARU dealer. Also have them adjusted after tire repairs and after tire rotation.

CAUTION

Loss of correct wheel alignment causes the tires to wear on one side and reduces the vehicle's running stability. Contact your SUBARU dealer if you notice abnormal tire wear.

NOTE

The suspension system is designed to hold each wheel at a certain alignment (relative to the other wheels and to the road) for optimum straight-line stability and cornering performance.

■ Wear indicators

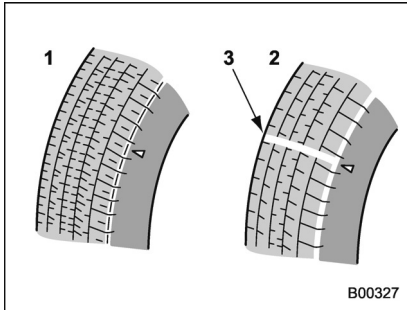

B00327

- 1) New tread
- 2) Worn tread
- 3) Tread wear indicator

Each tire incorporates a tread wear indicator, which becomes visible when the depth of the tread grooves decreases to 0.063 in (1.6 mm). A tire must be replaced when the tread wear indicator appears as a solid band across the tread.

WARNING

When a tire's tread wear indicator becomes visible, the tire is worn beyond the acceptable limit and must be replaced immediately. With a tire in this condition, driving at high speeds in wet weather can

cause the vehicle to hydroplane. The resulting loss of vehicle control can lead to an accident.

NOTE

For safety, inspect tire tread regularly and replace the tires before their tread wear indicators become visible.

■ Tire rotation direction mark

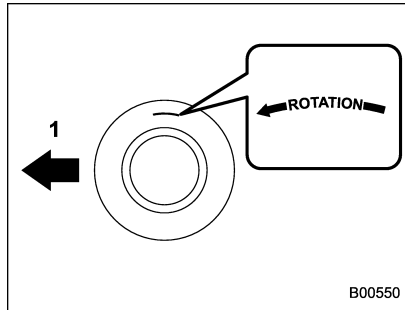

B00550

Example of tire rotation direction mark

- 1) Front

If the tire has the rotation direction specification, the tire rotation direction mark is placed on its sidewall.

When you install a tire that has the tire rotation direction mark, install the tire with

the direction mark facing forward.

■ Tire rotation

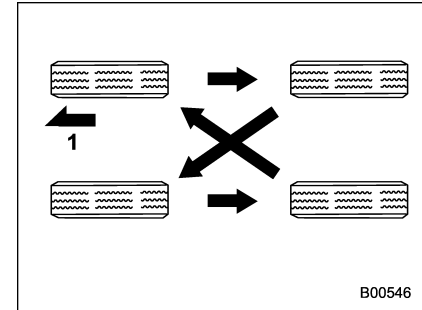

B00546

Vehicles equipped with 4 non-unidirectional tires

- 1) Front

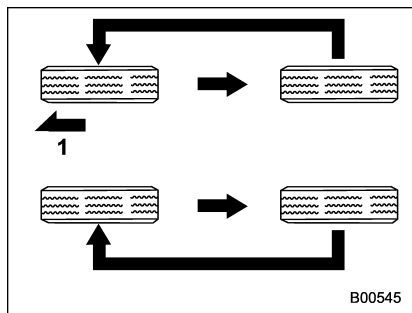

Vehicles equipped with unidirectional tires

1) Front

Tire wear varies from wheel to wheel. Move the tires to the positions shown in the illustration each time they are rotated. For the tire rotation schedule, refer to the "Warranty and Maintenance Booklet".

Replace any damaged or unevenly worn tires at the time of rotation. After tire rotation, adjust the tires pressures and make sure the wheel nuts are correctly tightened.

After driving approximately 600 miles (1,000 km), check the wheel nuts again and retighten any nut that has become loose.

For handling aluminum wheels (if equipped), refer to "Aluminum wheels"

11-28.

■ Tire replacement

The wheels and tires are important and integral parts of your vehicle's design; they cannot be changed arbitrarily. The tires fitted as standard equipment are optimally matched to the characteristics of the vehicle and were selected to give the best possible combination of running performance, ride comfort, and service life. It is essential for every tire to have a size and construction matching those shown on the tire placard and to have a speed symbol and load index matching those shown on the tire placard.

Using tires of a non-specified size detracts from controllability, ride comfort, braking performance, speedometer accuracy and odometer accuracy. It also creates incorrect body-to-tire clearances and inappropriately changes the vehicle's ground clearance.

All four tires must be the same in terms of manufacturer, brand (tread pattern), construction, and size. You are advised to replace the tires with new ones that are identical to those fitted as standard equipment.

For safe vehicle operation, SUBARU

recommends replacing all four tires at the same time.



WARNING

- **When replacing or installing tire (s), all four tires must be the same for following items.**

- (a) Size
- (b) Circumference
- (c) Speed symbol
- (d) Load index
- (e) Construction
- (f) Manufacturer
- (g) Brand (tread pattern)
- (h) Degrees of wear

For the items (a) to (d), you must obey the specification that is printed on the tire placard. The tire placard is located on the driver's door pillar.

If all of four tires are not the same for items (a) to (h), serious mechanical damage could occur to the drive train of your car, and affect the following.

- Ride
- Handling
- Braking

— Speedometer/Odometer calibration

— Clearance between the body and tires

It also may be dangerous and lead to loss of vehicle control, and it can lead to an accident.

- Use only radial tires. Do not use radial tires together with belted bias tires and/or bias-ply tires. Doing so can dangerously reduce controllability, resulting in an accident.

■ Wheel replacement

When replacing wheels due, for example, to damage, make sure the replacement wheels match the specifications of the wheels that are fitted as standard equipment. Replacement wheels are available from SUBARU dealers.

⚠ WARNING

Use only those wheels that are specified for your vehicle. Wheels not meeting specifications could interfere with brake caliper operation and may cause the tires to rub against the wheel well housing during turns. The resulting loss of vehicle control could lead to an accident.

NOTE

When any of the wheels are removed and replaced for tire rotation or for any other reason, always check the tightness of the wheel nuts after driving approximately 600 miles (1,000 km). If any nut is loose, tighten it to the specified torque.

■ Wheel covers (if equipped)

▼ Removing the wheel cover

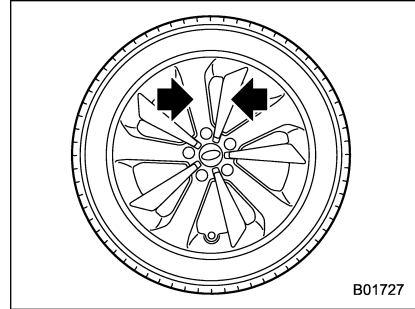

If your vehicle has wheel covers, remove them by holding and pulling the areas indicated in the illustration.

⚠ CAUTION

Use gloves to protect your hands when removing wheel covers.

▼ Installing the wheel cover

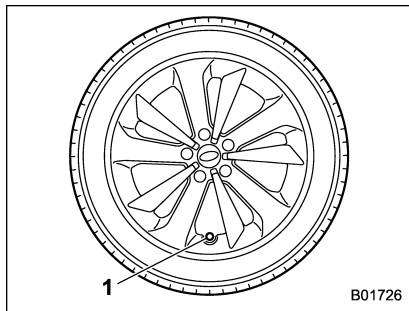

1) Valve hole

B01726

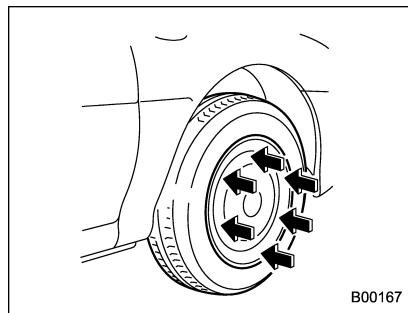

B00167

Align the valve with the valve hole in the cover, then fit the cover on the wheel by tapping your hand evenly around the circumference of the cover.

Aluminum wheels (if equipped)

Aluminum wheels can be scratched and damaged easily. Handle them carefully to maintain their appearance, performance, and safety.

- When any of the wheels are removed and replaced for tire rotation or to change a flat tire, always check the tightness of the wheel nuts after driving approximately 600 miles (1,000 km). If any nut is loose, tighten it to the specified torque.
- Never apply oil to the threaded parts, wheel nuts, or tapered surface of the wheel.
- Never let the wheel rub against sharp protrusions or curbs.
- When wheel nuts, balance weights, or the center cap is replaced, be sure to replace them with genuine SUBARU parts designed for aluminum wheels.
- When stacking and storing removed tires, place shock-absorbing material between the tires to protect the wheels from becoming scratched.

Windshield washer fluid

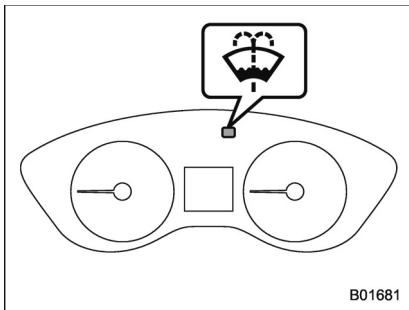

B01681

Windshield washer fluid warning light (type A)

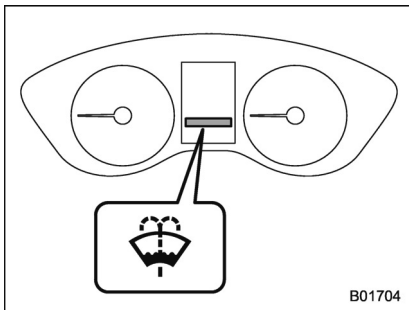

B01704

Windshield washer fluid warning light (type B)

When there is only a small amount of washer fluid remaining, the windshield washer fluid warning light will illuminate. When this occurs, refill the washer fluid.

■ Adding the windshield washer fluid



CAUTION

Never use engine coolant as washer fluid because it could cause paint damage.

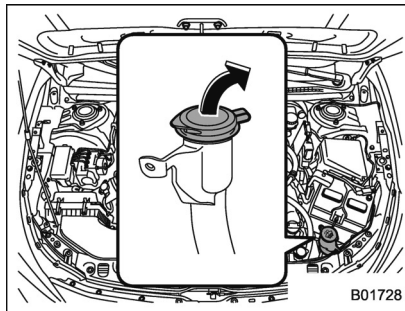

B01728

Remove the washer tank filler cap, then add windshield washer fluid.

■ Windshield washer fluid

Use windshield washer fluid. If windshield washer fluid is unavailable use clean water.

In areas where water freezes in winter, use an anti-freeze type windshield washer fluid. SUBARU Windshield Washer Fluid contains 58.5% methyl alcohol and 41.5% surfactant, by volume. Its freezing temperature varies according to how much it is diluted, as indicated in the following table.

Washer Fluid Concentration	Freezing Temperature
30%	10.4° F (-12° C)
50%	-4° F (-20° C)
100%	-49° F (-45° C)

In order to prevent freezing of washer fluid, check the freezing temperatures in the table above when adjusting the fluid concentration to the outside temperature.

If you fill the reservoir tank with a fluid with a different concentration from the one used previously, purge the old fluid from the piping between the reservoir tank and washer nozzles by operating the washer for a certain period of time. Otherwise, if the concentration of the fluid remaining in the piping is too low for the outside

temperature, it may freeze and block the nozzles.

CAUTION

- **Adjust the washer fluid concentration appropriately for the outside temperature. If the concentration is inappropriate, sprayed washer fluid may freeze on the windshield and obstruct your view, and the fluid may freeze in the reservoir tank.**
- **State or local regulations on volatile organic compounds may restrict the use of methanol, a common windshield washer anti-freeze additive. Washer fluids containing non-methanol anti-freeze agents should be used only if they provide cold weather protection without damaging your vehicle's paint, wiper blades or washer system.**

Replacement of wiper blades

Grease, wax, insects, or other material on the windshield or the wiper blade results in jerky wiper operation and streaking on the glass. If you cannot remove the streaks after operating the windshield washer or if the wiper operation is jerky, clean the outer surface of the windshield (or rear window) and the wiper blades using a sponge or soft cloth with a neutral detergent or mild-abrasive cleaner. After cleaning, rinse the windshield and wiper blades with clean water. The windshield is clean if beads do not form when you rinse the windshield with water.

CAUTION

- **Do not clean the wiper blades with gasoline or a solvent, such as paint thinner or benzene. This will cause deterioration of the wiper blades.**
- **While removing the wiper blades from the wiper arms, do not return the wiper arms to the original positions. Otherwise, the windshield surface may be scratched.**
- **When returning the raised wiper arms to the original positions,**

carefully return the wiper arms on the windshield by hand. You should not return the wiper arms to the windshield only by the return spring. Otherwise, the wiper arms may be deformed and/or the windshield surface may be scratched.

If you cannot eliminate the streaking even after following this method, replace the wiper blades using the following procedures.

Windshield wiper blade assembly

1. **Raise the wiper arm off the windshield.**

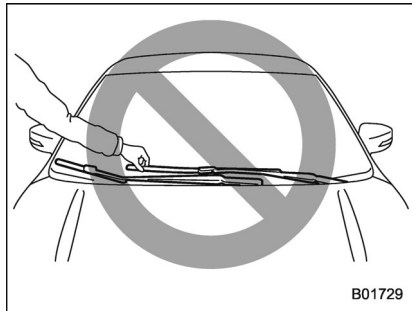

B01729

CAUTION

Hold the wiper arm when replacing the wiper blade. Holding the wiper blade, may result in blade deformation.

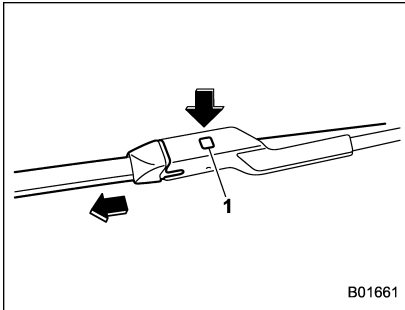

B01661

1) Lock knob

2. Hold the wiper blade connection by hand, push the lock knob to release the lock, and then pull out the wiper blade assembly.

NOTE

Do not use a hard object to push the lock knob. The lock knob may be scratched.

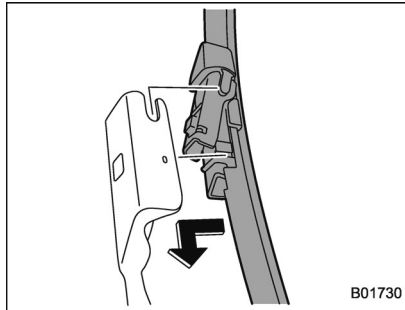

B01730

3. When installing the wiper blade assembly, align it with the wiper arm connection part and then slide it in the opposite direction of removal to install. After installing the wiper blade assembly, check that the connection part is locked completely.

4. Hold the wiper arm by hand and slowly lower it in position.

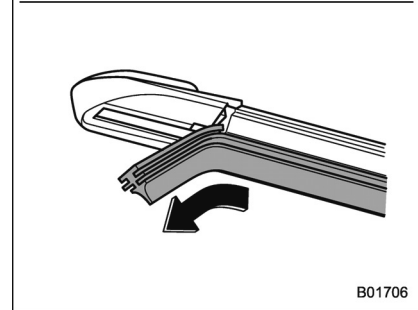
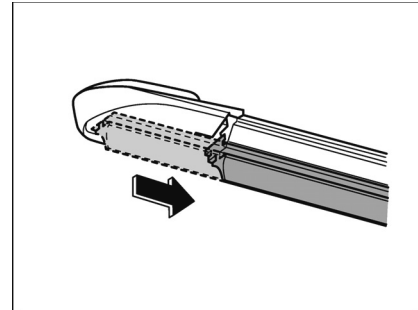
Window wiper blade rubber

B01706

Replace the wiper blade rubber according to the following procedure.

1. Pull the wiper blade rubber until the slit on the underside of the wiper blade is in the removal position, as shown in the

illustration, so that it can be removed.

2. Pull the end of the wiper blade rubber through the slit to remove it.
3. To install a new wiper blade rubber, perform the removal procedure in the reverse order. After installation, check that the tip of the wiper rubber has reached the end of the cap.

NOTE

It may be difficult to perform the wiper blade rubber replacement. We recommend that you contact your SUBARU dealer for wiper blade rubber replacement if necessary.

■ Rear window wiper blade assembly

1. Raise the wiper arm off the rear window.

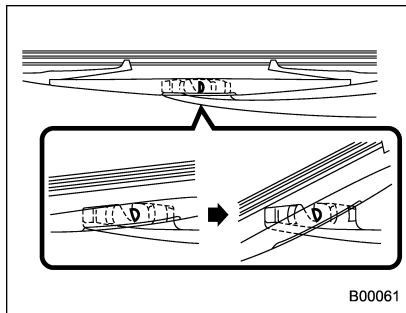

2. Turn the wiper blade assembly counterclockwise.

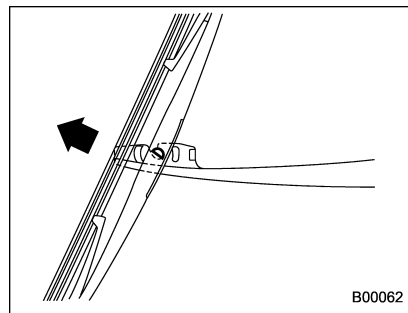

3. Pull the wiper blade assembly toward you to remove it from the wiper arm.
4. Install the wiper blade assembly to the wiper arm. Make sure that it locks in place.
5. Hold the wiper arm by hand and slowly lower it in position.

■ **Rear window wiper blade rubber**

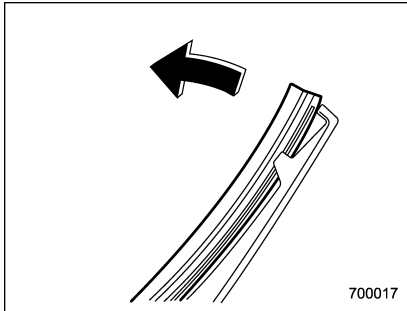

1. Pull out the end of the blade rubber assembly to unlock it from the plastic support.

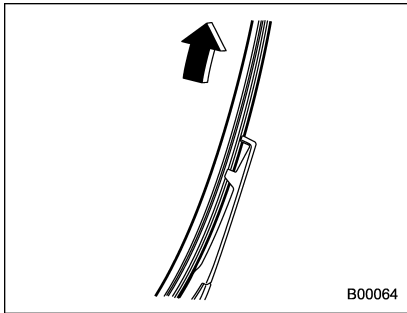

2. Pull the blade rubber assembly out of the plastic support.

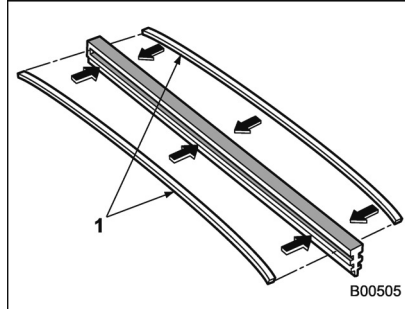

1) Metal spines

3. If the new blade rubber is not provided with two metal spines, remove the metal spines from the old blade rubber and install them in the new blade rubber.

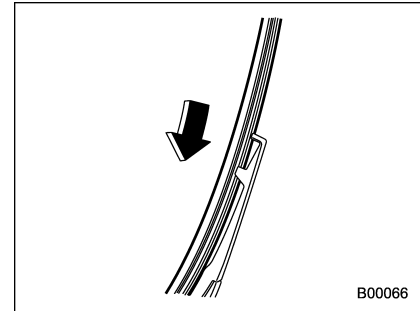

4. Align the claws of the plastic support with the grooves in the blade rubber assembly, then slide the blade rubber assembly into place.

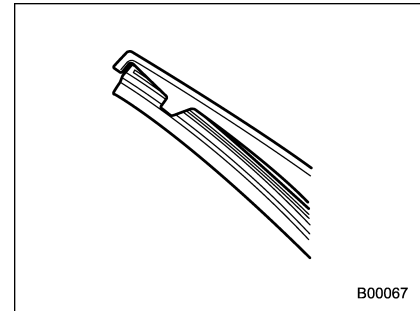

Securely retain both ends of the rubber with the stoppers on the plastic support

ends. If the rubber is not retained properly, the wiper may scratch the rear window glass.

5. Install the wiper blade assembly to the wiper arm. Make sure that it locks in place.

6. Hold the wiper arm by hand and slowly lower it in position.

Battery

WARNING

- Before beginning work on or near any battery, be sure to extinguish all cigarettes, matches, and lighters. Never expose a battery to an open flame or electric sparks. Batteries give off a gas which is highly flammable and explosive.
- For safety, in case an explosion does occur, wear eye protection or shield your eyes when working near any battery. Never lean over a battery.
- Do not let battery fluid contact eyes, skin, fabrics, or paint because battery fluid is a corrosive acid. If battery fluid gets on your skin or in your eyes, immediately flush the area with water thoroughly. Seek medical help immediately if acid has entered the eyes.

If battery fluid is accidentally swallowed, immediately drink a large amount of milk or water, and seek medical attention immediately.

- To lessen the risk of sparks, remove rings, metal watchbands, and other metal jewelry. Never allow metal tools to contact the positive battery terminal and anything connected to it WHILE you are at the same time in contact with any other metallic portion of the vehicle because a short circuit will result.
- Keep everyone including children away from the battery.
- Charge the battery in a well-ventilated area.
- Battery posts, terminals and related accessories contain lead and lead compounds, chemicals known to the State of California to cause cancer and reproductive harm. Batteries also contain other chemicals known to the State of California to cause cancer. *Wash hands after handling.*

CAUTION

Never use more than 10 amperes when charging the battery because it will shorten battery life.

It is unnecessary to periodically check the

battery fluid level or periodically refill with distilled water.

Fuses

CAUTION

Never replace a fuse with one having a higher rating or with material other than a fuse because serious damage or a fire could result.

The fuses are designed to melt during an overload to prevent damage to the wiring harness and electrical equipment. The fuses are located in two fuse boxes.

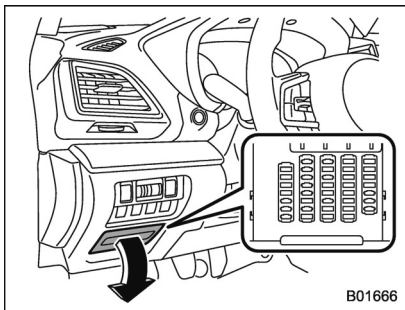

One is located under the instrument panel behind the fuse box cover on the driver's seat side. To remove the cover, pull it out.

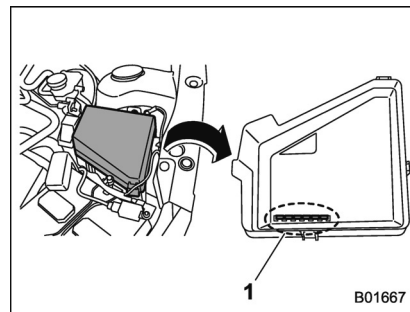

1) Spare fuses

The other one (main fuse box) is housed in the engine compartment. Also, the spare fuses are stored in the fuse box cover.

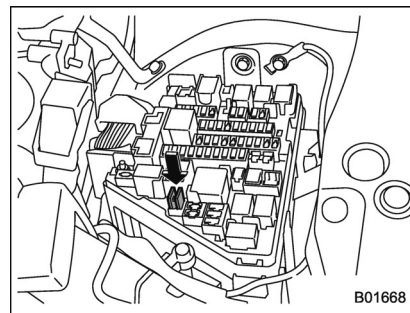

The fuse puller is stored in the main fuse

box in the engine compartment.

Pinch the upper part of the fuse puller when removing it from the main fuse box.

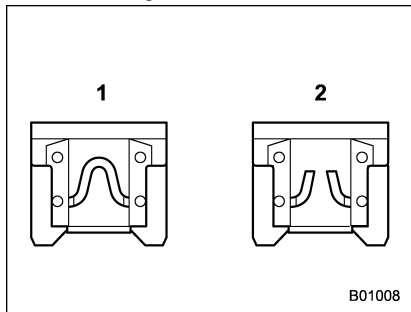

- 1) Good
- 2) Blown

If any lights, accessories or other electrical controls do not operate, inspect the corresponding fuse. If a fuse has blown, replace it.

1. Turn the ignition switch to the "LOCK"/"OFF" position and turn off all electrical accessories.
2. Remove the cover.
3. Determine which fuse may be blown. Look at the back side of each fuse box cover and refer to "Fuses and circuits"  12-10.

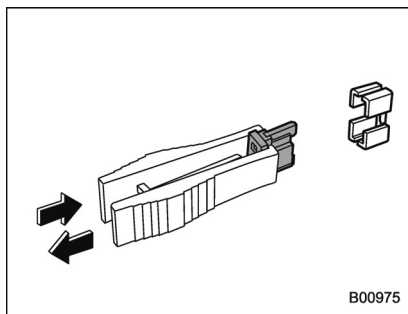

4. Pull out the fuse with the fuse puller.
5. Inspect the fuse. If it has blown, replace it with a spare fuse of the same rating.
6. If the same fuse blows again, this indicates that its system has a problem. Contact your SUBARU dealer for repairs.

Installation of accessories

Always consult your SUBARU dealer before installing fog lights or any other electrical equipment in your vehicle. Such accessories may cause the electronic system to malfunction if they are incorrectly installed or if they are not suited for the vehicle.

Replacing bulbs

WARNING

Bulbs may become very hot while illuminated. Before replacing bulbs, turn off the lights and wait until the bulbs cool down. Otherwise, there is a risk of sustaining a burn injury.

CAUTION

Replace any bulb only with a new bulb of the specified wattage. Using a bulb of different wattage could result in a fire. For the specified wattage of each bulb, refer to "Bulb chart" 12-14.

NOTE

For models with type B combination meter, if SRH is malfunctioning, the SRH OFF indicator appears on the combination meter when the ignition switch is in the "ON" position. It indicates that SRH has been deactivated. Contact a SUBARU dealer for an inspection.

Headlights (models with LED headlights)

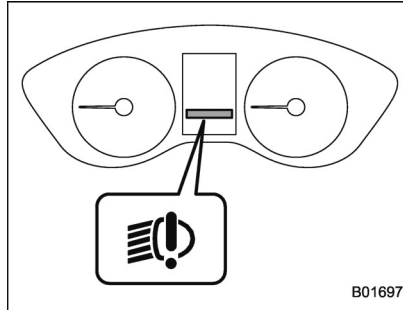

B01697

LED headlight warning light (type B)

The LED headlight warning light illuminates if the LED headlights malfunction. Have your vehicle inspected at a SUBARU dealer as soon as possible.

Headlights (models with halogen headlights)

CAUTION

Halogen headlight bulbs become very hot while in use. If you touch the bulb surface with bare hands or greasy gloves, fingerprints or grease on the bulb surface will develop into hot spots, causing the bulb to break. If there are fingerprints or grease on the bulb surface, wipe them away with a soft cloth moistened with alcohol.

NOTE

- If headlight aiming is required, consult your SUBARU dealer for proper adjustment of the headlight aim.
- It may be difficult to replace the bulbs. Have the bulbs replaced by your SUBARU dealer if necessary.

Perform the following steps to replace the bulbs.

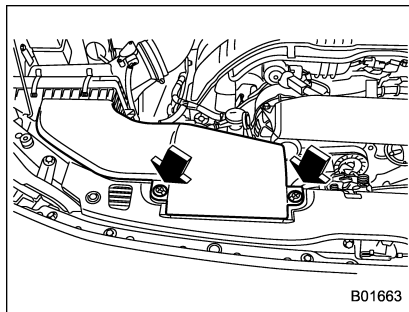

Right-hand side

1. Use a screwdriver to undo the clips on the air intake duct, then remove the air intake duct.

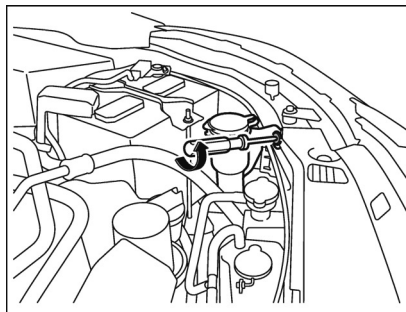

Left-hand side

2. Use a screwdriver to remove the secured clip of the washer tank. To make it easy to access the bulb, turn the neck of the washer fluid filler pipe as illustrated.

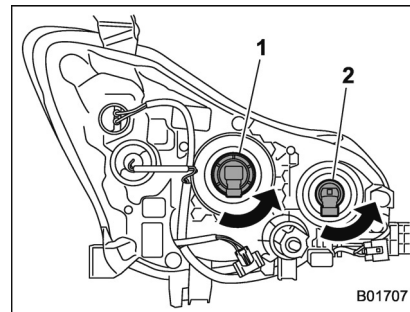

- 1) Low beam bulb
- 2) High beam bulb

- 3. Disconnect the electrical connector from the bulb and remove the bulb from the headlight assembly by turning it counterclockwise.
- 4. Replace the bulb with new one. At this time, use care not to touch the bulb surface.
- 5. To install the bulb to the headlight assembly, turn it clockwise until it clicks.
- 6. Reconnect the electrical connector.
- 7. Install the air intake duct with clips (right-hand side).
- 8. Set the washer fluid filler pipe to the original place and secure it by clip (left-hand side).

■ Front turn signal light

It may be difficult to replace the bulbs. Have the bulbs replaced by your SUBARU dealer if necessary.

■ Parking light

It may be difficult to replace the bulbs. Have the bulbs replaced by your SUBARU dealer if necessary.

■ Front fog light (if equipped)

It may be difficult to replace the bulbs. Have the bulbs replaced by your SUBARU dealer if necessary.

■ Rear combination lights

▼ Sedan

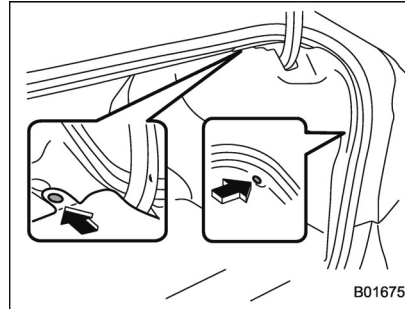

1. Remove the clips from the trunk trim with a flat-head screwdriver.

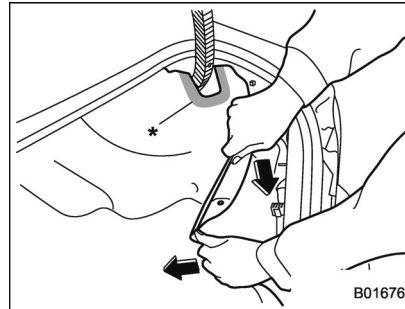

2. Open the rear portion of the trunk trim

panel as illustrated.

NOTE

Make sure that the “*” part of the trunk trim in the illustration does not contact the trunk lid stay. If the “*” part is bent, the trunk trim may be torn.

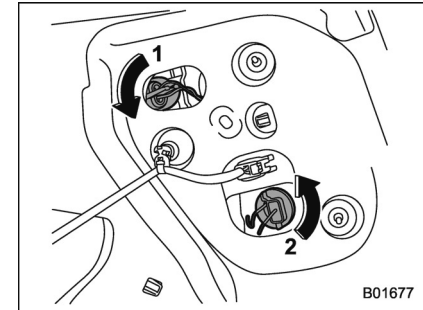

- 1) Tail and rear side marker light
- 2) Rear turn signal light

3. Remove the bulb socket from the rear combination light assembly by turning it counterclockwise.

4. Pull the bulb out of the bulb socket and replace it with a new one.

5. Set the bulb socket into the rear combination light assembly and turn it clockwise until it locks.

6. Secure the rear trunk trim panel with

the clips.

▼ 5-door models

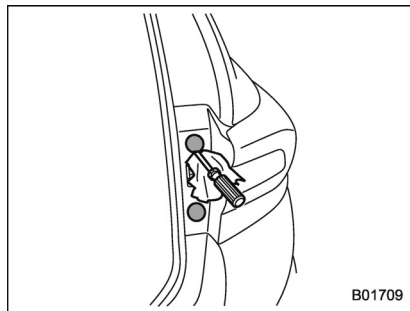

1. Remove the covers.

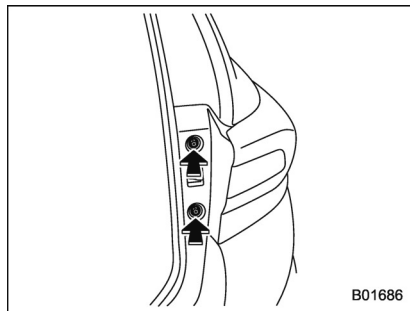

2. Using a Phillips screwdriver, remove the upper and lower screws that secure

the rear combination light assembly.

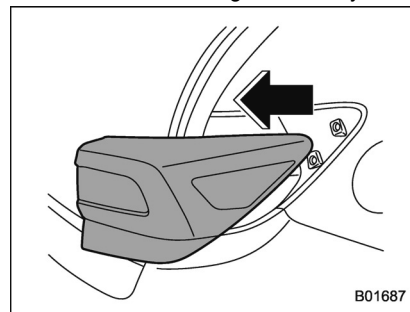

3. Slide the rear combination light assembly rearward and remove it from the vehicle.

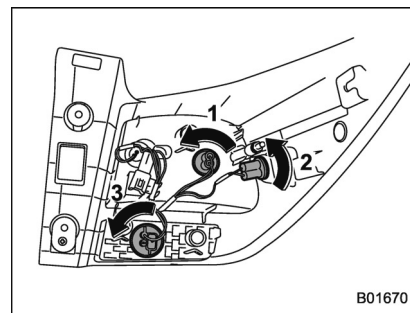

- 1) Tail light
- 2) Rear side marker light
- 3) Rear turn signal light

4. Remove the bulb socket from the rear combination light assembly by turning it counterclockwise.

5. Pull the bulb out of the bulb socket and replace it with a new one.

6. Set the bulb socket into the rear combination light assembly and turn it clockwise until it locks.

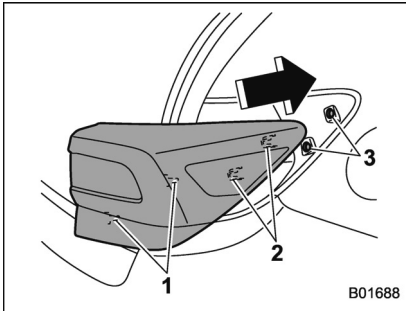

- 1) Guide pins
- 2) Catch
- 3) Clip

7. Put the rear combination light assembly into place while aligning the 2 guide pins and a catch with the guide holes and a clip on the vehicle.

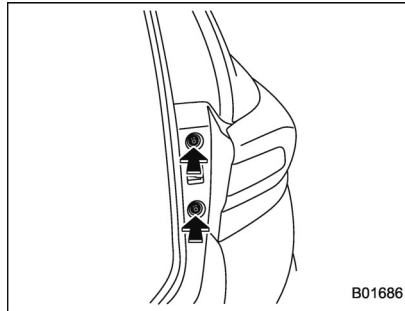

8. Tighten the upper and lower screws.
9. Reinstall the covers.

■ Backup light

▼ Sedan

NOTE

It may be difficult to replace the bulbs. We recommend that you have the bulbs replaced by your SUBARU dealer if necessary.

1. Open the trunk.

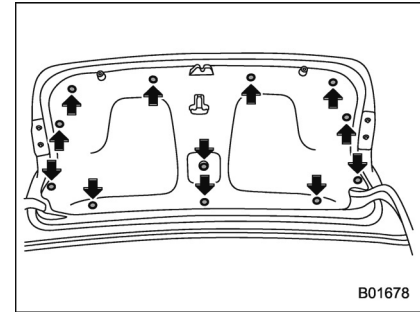

2. Remove the trunk trim lining by removing the clips indicated in the illustration.

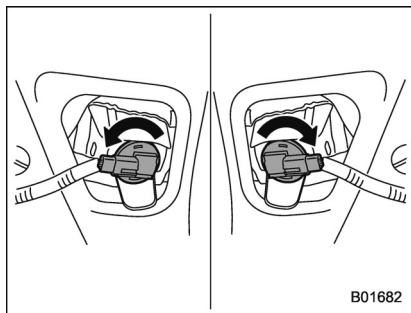

3. For left side light, turn the bulb socket clockwise and remove it.
For right side light, turn the bulb socket counterclockwise and remove it.
4. Pull the bulb out of the bulb socket and replace it with a new one.
5. Install the bulb socket by turning it clockwise.
6. Reconnect the electrical connector.
7. Reinstall the trunk trim lining.

▼ **5-door models**

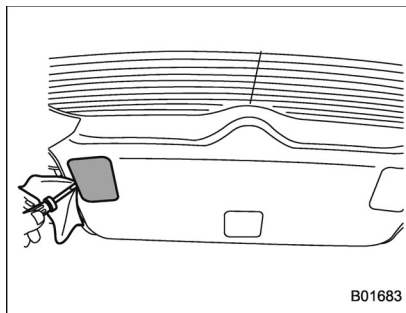

1. Apply a flat-head screwdriver to the light cover as shown in the illustration, and pry the light cover off from the rear gate trim.

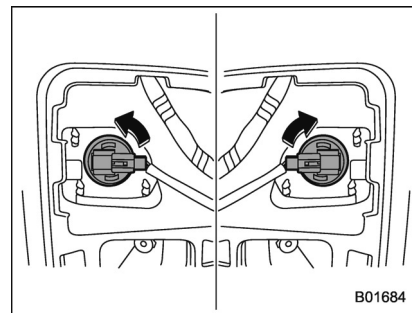

2. For left side light, turn the bulb socket clockwise and remove it.
For right side light, turn the bulb socket counterclockwise and remove it.

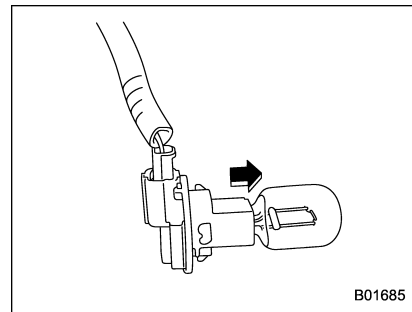

3. Pull the bulb out of the bulb socket and replace it with a new one.

4. Install the bulb socket by turning it clockwise.
5. Install the light cover on the rear gate.

■ License plate light

▼ Sedan

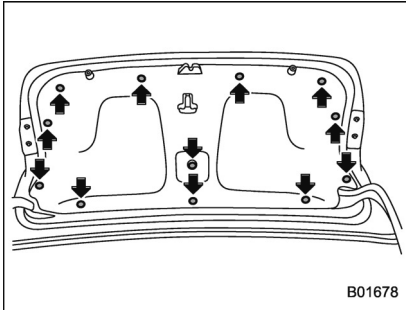

1. Open the trunk and remove the clips from the trunk lid trim with a flat-head screwdriver.

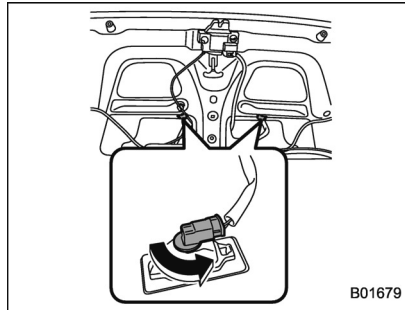

2. Turn the bulb socket counterclockwise and pull out the socket.
3. Pull the bulb out of the socket.
4. Install a new bulb.
5. Reinstall the bulb socket and the trunk lid trim.

▼ 5-door models

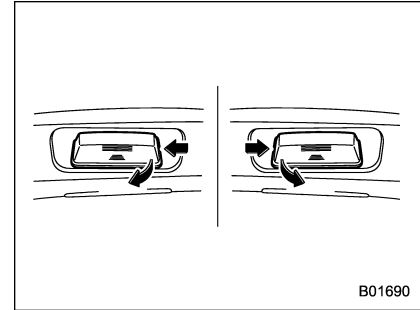

1. The license plate lights must be pushed outwards, and then pulled out to be removed.

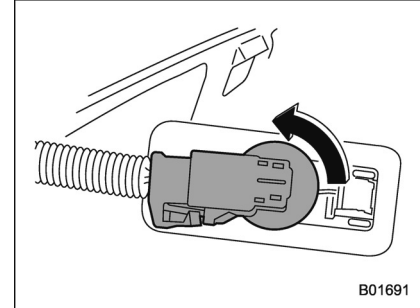

2. Turn the bulb socket counterclockwise and pull out the socket.

3. Pull the bulb out of the socket.
4. Install a new bulb.
5. Reinstall the bulb socket and the license plate light cover.

■ Map light

CAUTION

Replacing the bulb could cause burns since the bulb may be very hot. Have the bulb replaced by your SUBARU dealer.

■ Vanity mirror light (if equipped)

CAUTION

Replacing the bulb could cause burns since the bulb may be very hot. Have the bulb replaced by your SUBARU dealer.

■ Dome light and cargo area light

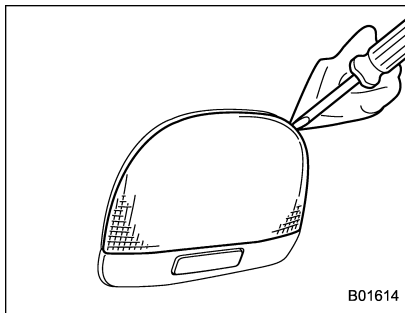

Dome light

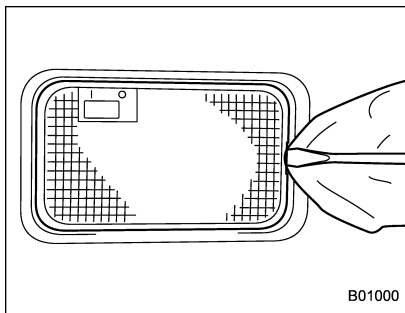

Cargo area light

1. Remove the lens by prying the edge of

- the lens with a flat-head screwdriver.
2. Pull the bulb out of the socket.
3. Install a new bulb.
4. Reinstall the lens.

■ Trunk light

CAUTION

Replacing the bulb could cause burns since the bulb may be very hot. Have the bulb replaced by your SUBARU dealer.

■ Other bulbs

It may be difficult to replace the bulbs. Have the bulbs replaced by your SUBARU dealer if necessary.

Replacing key battery

The access key fob/transmitter battery may be discharged under the following conditions.

- The operation of the keyless access function is unstable
- The operating distance of the remote keyless entry system is unstable
- The transmitter does not operate properly when used within the standard distance

Replace the battery with a new one.

■ Safety precautions

⚠ CAUTION

- Do not let dust, oil or water get on or in the access key fob/transmitter when replacing battery.
- Be careful not to touch or damage the printed circuit board in the access key fob/transmitter when replacing the battery.
- Be careful not to allow children to touch the battery and any removed parts; children could swallow them.
- There is a danger of an explosion

if the battery is incorrectly replaced. Replace only with the same or equivalent type of the battery.

- Batteries should not be exposed to excessive heat such as bright sunlight, fire or the like.

NOTE

- Replace only with the same or equivalent type of battery recommended by the manufacturer.
- Dispose of used batteries according to local laws.
- Mount the battery in the correct orientation to prevent fluid leakage. Be careful not to bend the terminals. It may result in a malfunction.
- It is recommended that the battery be replaced by a SUBARU dealer.
- Use a new battery.
- After replacing the battery, confirm that the transmitter functions properly.

■ Replacing battery of access key fob

⚠ CAUTION

When removing or reinstalling the access key fob cover, make sure that the plastic part does not come off or become misaligned.

Battery: Button battery CR2032

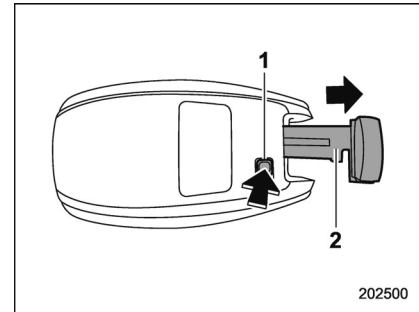

- 1) Release button
- 2) Emergency key

1. Take out the emergency key.

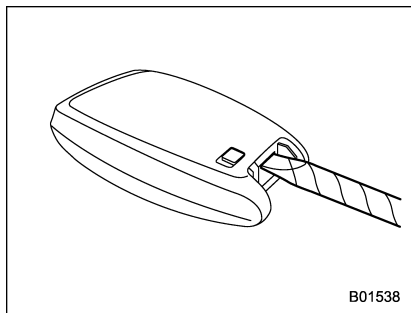

2. Wrap a flat-head screwdriver with vinyl tape or a cloth, and insert it in the gap to remove the cover.

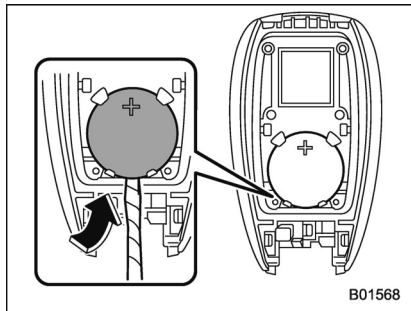

3. Take out the battery using a flat-head screwdriver with vinyl tape or a cloth.

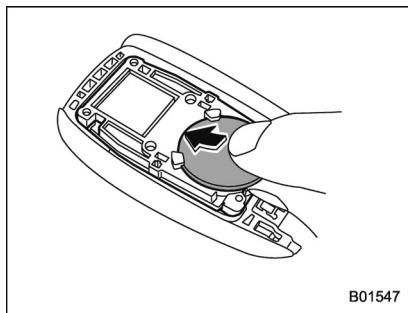

4. Insert a new battery with its positive (+) side facing upward as shown in the figure.

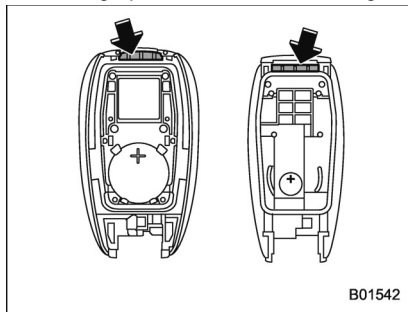

5. Attach the cover to the access key fob by fitting the projections and recesses together.

■ Replacing transmitter battery

Battery: Button battery CR1620 or equivalent

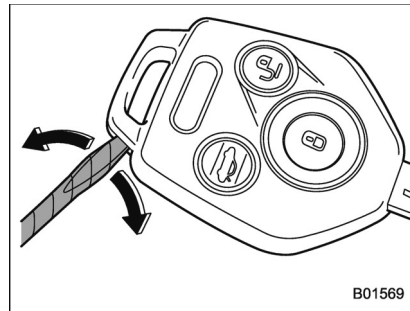

1. Wrap a flat-head screwdriver with vinyl tape or a cloth. Open the key head using a flat-head screwdriver.

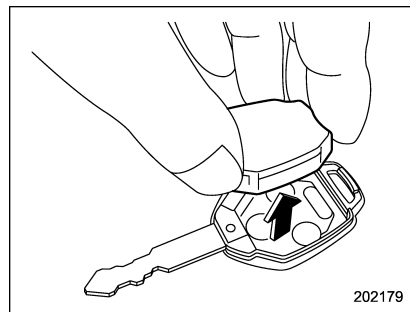

2. Remove the transmitter case from the key head.

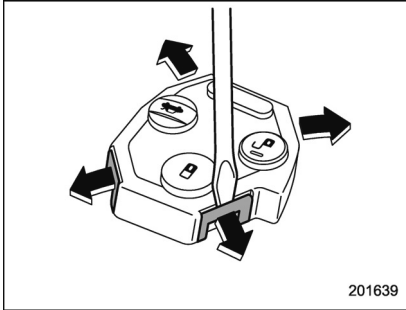

3. Open the transmitter case by releasing the hooks.

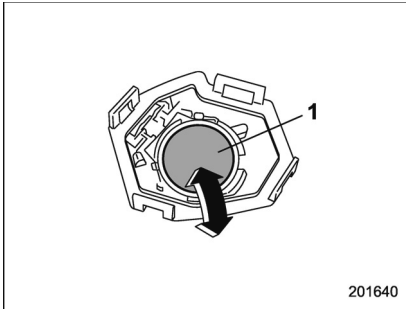

1) Negative (-) side facing up

4. Replace the old battery with a new battery making sure to install the new battery with the negative (-) side facing up.

5. Put together the transmitter case by fitting the hooks on the case.

6. Reinstall the transmitter case in the key head.

7. Refit the removed half of the key head.

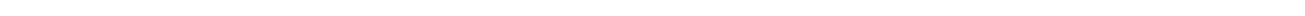
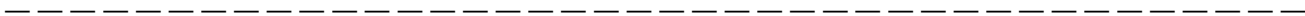
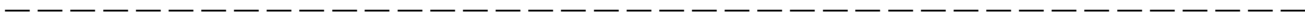

Specifications	12-2	Brake disc	12-9
Dimensions	12-2	Fuses and circuits	12-10
Engine	12-3	Fuse panel located in the passenger compartment	12-10
Fuel	12-3	Fuse panel located in the engine compartment	12-12
Engine oil	12-4	Bulb chart	12-14
Manual transmission, front differential and rear differential gear oil	12-6	Safety precautions	12-14
Fluids	12-7	Bulb chart	12-15
Engine coolant	12-7	Vehicle identification	12-18
Electrical system	12-8		
Tires	12-8		
Temporary spare tires	12-9		

Specifications

These specifications are subject to change without notice.

■ Dimensions

		in (mm)	
Item		5-door models	Sedan
Overall length		175.6 (4,460)	182.1 (4,625)
Overall width		70.0 (1,775)	
Overall height	Models with roof rails	58.9 (1,495)	57.3 (1,455)
	Models without roof rails	58.3 (1,480)* ¹ 57.3 (1,455)* ²	
Wheel base		105.1 (2,670)	
Tread	Front	60.6 (1,540)	
	Rear	60.8 (1,545)	
Ground clearance* ³		5.1 (130)	

*1: Models with shark fin type roof antenna

*2: Models with monopole roof antenna

*3: Measured with vehicle empty

■ Engine

Engine model	FB20 (2.0 L, DOHC, non-turbo)
Engine type	Horizontally opposed, liquid cooled 4 cylinder, 4-stroke direct injection gasoline engine
Displacement cu-in (cc)	121.7 (1,995)
Bore × Stroke in (mm)	3.31 × 3.54 (84.0 × 90.0)
Compression ratio	12.5 : 1
Firing order	1 – 3 – 2 – 4

■ Fuel

Fuel requirement	Fuel tank capacity
Unleaded gasoline with 87 AKI (90 RON) or higher	13.2 US gal (50 liters, 11.0 Imp gal)

For more details, refer to "Fuel" ☞ 7-3.

■ **Engine oil**

For the checking, adding and replacing procedure or other details, refer to “Engine oil” 11-8.

NOTE

The procedure for changing the engine oil and oil filter should be performed by a properly-trained expert. It is recommended that you have this service performed by your SUBARU dealer.

▼ **Approved engine oil**



Always use the SUBARU approved engine oil. For further details, please contact your SUBARU dealer.
If the approved engine oil is unavailable, use the alternative engine oil described on the next page.

▼ **Alternative engine oil**

If the SUBARU approved oil is unavailable, the following alternative oil can be used.

NOTE

Each quantity indicated here is only a guideline. The necessary quantity for replacement may differ slightly depending on the temperature and other factors.

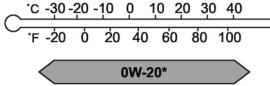
Oil grade	SAE viscosity No. and applicable temperature	Engine oil capacity
<div style="display: flex; justify-content: space-around; align-items: center;"> <div style="text-align: center;">  <p>ZOM0377</p> <p>API (American Petroleum Institute) classification SN with the words "RESOURCE CONSERVING"</p> </div> <div style="text-align: center;"> <p>or</p>  <p>ZOM0293</p> <p>ILSAC (International Lubricant Specification Advisory Committee) GF-5, which can be identified with the ILSAC certification mark (Starburst mark)</p> </div> </div>	<p>0W-20 synthetic oil is the required oil for optimum engine performance and protection. Conventional oil may be used if synthetic oil is unavailable.</p> <p>*: If 0W-20 synthetic oil is not available, 5W-30 conventional oil may be used if replenishment is needed but should be changed to 0W-20 synthetic oil at the next oil change.</p> <div style="text-align: center;">  <p>ZOM0294</p> </div>	<ul style="list-style-type: none"> - Adding the oil from low level to full level: 1.1 US qt (1.0 liter, 0.9 Imp qt) - Changing the oil and oil filter: 4.7 US qt (4.4 liters, 3.9 Imp qt)

Manual transmission, front differential and rear differential gear oil

Oil	Manual transmission oil	Front differential gear oil (CVT models)	Rear differential gear oil (CVT models)	Rear differential gear oil (MT models)
Oil grade	<ul style="list-style-type: none"> SUBARU Extra MT*³ API classification GL-5 (75W-90)*⁴ 	<ul style="list-style-type: none"> SUBARU Extra MT*³ API classification GL-5 (75W-90) 		API classification GL-5
SAE viscosity No. and applicable temperature	—			<ul style="list-style-type: none"> 75W-90* 90 <p style="text-align: right;">ZOM0450</p>
Oil capacity* ¹	3.7 US qt (3.5 liters, 3.1 Imp qt)	1.4 US qt (1.3 liters, 1.1 Imp qt)	0.8 US qt (0.8 liters, 0.7 Imp qt)	
Remarks* ²	"Manual transmission oil" ☞ 11-14	"Front differential gear oil (CVT models) and rear differential gear oil" ☞ 11-15		

*1: The indicated oil quantity is only a guideline. The necessary quantity for replacement may differ slightly depending on the temperature and other factors. After refilling the gearbox with oil, the oil level should be checked.

*2: For more details about maintenance and service, refer to the indicated section.

*3: The vehicle is filled at the factory with this type of oil.

*4: You may use this type of manual transmission oil. However, using this type of oil will detract from driveability and fuel efficiency.

■ Fluids

Fluid	Fluid type*1	Fluid capacity*2	Remarks*3
Continuously variable transmission fluid (CVT models)	Consult your SUBARU dealer.	11.3 US qt (10.7 liters, 9.4 Imp qt)	"Continuously variable transmission fluid" ☞ 11-15
Brake fluid	FMVSS No. 116, fresh DOT 3 or DOT 4 brake fluid	–	"Brake fluid" ☞ 11-15
Clutch fluid (MT models)	FMVSS No. 116, fresh DOT 3 or DOT 4 brake fluid	–	"Clutch fluid (MT models)" ☞ 11-16

*1: Use one of the indicated types of fluid.

*2: The indicated fluid quantity is only a guideline. The necessary quantity for replacement may differ slightly depending on the temperature and other factors.

*3: For more details about maintenance and service, refer to the indicated section.

■ Engine coolant

Vehicle model	Coolant capacity	Coolant type
MT models	8.0 US qt (7.6 liters, 6.7 Imp qt)	SUBARU Super Coolant
CVT models	8.2 US qt (7.8 liters, 6.9 Imp qt)	

The indicated coolant quantity is only a guideline. The necessary quantity for replacement may differ slightly depending on the temperature and other factors. For more details about maintenance and service, refer to "Cooling system" ☞ 11-10.

■ Electrical system

Battery type	75D23L
Alternator	12V-130A
Spark plugs	DILKAR7B8 (NGK)

■ Tires

Tire size	P205/55R16 89V	205/50R17 89V	P225/40R18 88V
Wheel size	16 × 6 1/2 J	17 × 7 J	18 × 7 1/2 J
Pressure	Front	33 psi (230 kPa, 2.3 kgf/cm ²)	
	Rear	32 psi (220 kPa, 2.2 kgf/cm ²)	
Wheel nut tightening torque	89 lbf-ft (120 N·m, 12 kgf·m)*1		

*1: This torque is equivalent to applying approximately 88 to 110 lbf (40 to 50 kgf) at the end of the wheel nut wrench. If you have tightened the wheel nuts by yourself, have the tightening torque checked at the nearest automotive service facility as soon as possible. For the wheel nut tightening procedure, refer to "Changing a flat tire" 9-6.

■ Temporary spare tires

	U.S.-spec. models and Canada-spec. models	Other models	
Temporary spare tire size	T135/80 D16	P205/55 R16 89V	205/50 R17 89V
Temporary spare tire inflation pressure (recommended cold tire inflation pressure)	60 psi (420 kPa, 4.2 kgf/cm ²)	33 psi (230 kPa, 2.3 kgf/cm ²)	

■ Brake disc

If you need information on the usage limit value of brake discs and the method for measuring them, we recommend that you consult your SUBARU dealer.

Fuses and circuits

■ Fuse panel located in the passenger compartment

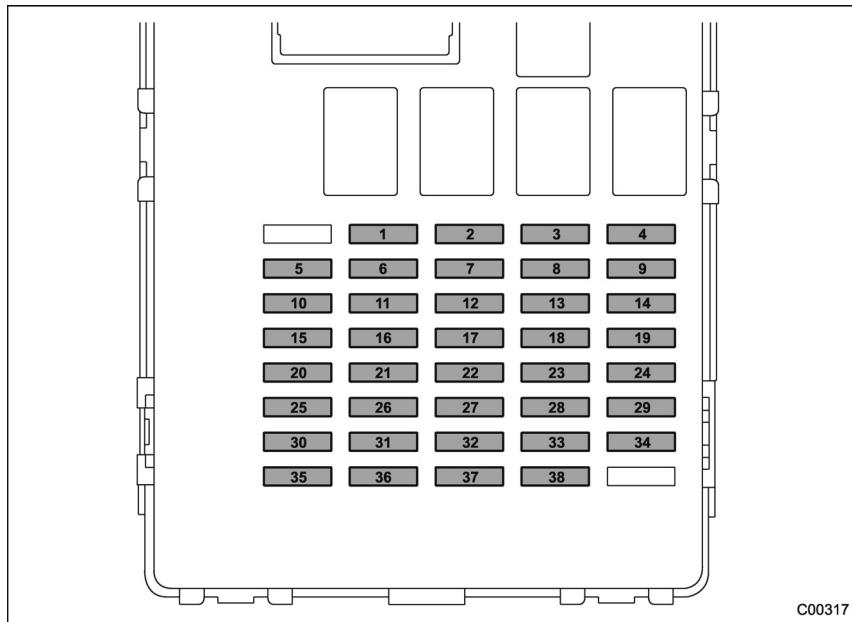

C00317

Fuse panel	Fuse rating	Circuit
1	Empty	
2	20A	CIGAR SEAT/H
3	7.5A	IG A-1
4	15A	AUDIO NAVI
5	15A	IG B-2
6	Empty	
7	15A	12V SOCKET
8	15A	A/C IG
9	7.5A	ACC
10	7.5A	IG B-1
11	Empty	
12	Empty	
13	7.5A	IG A-3
14	7.5A	UNIT +B
15	7.5A	METER IG
16	Empty	
17	7.5A	MIRROR
18	7.5A	LAMP IG
19	10A	IG A-2
20	10A	SRS AIR BAG
21	Empty	
22	15A	STRG/H

Fuse panel	Fuse rating	Circuit
23	10A	DRL
24	Empty	
25	Empty	
26	10A	BACK UP
27	Empty	
28	20A	TRAIL R.FOG
29	Empty	
30	Empty	
31	Empty	
32	7.5A	ILLUMI
33	7.5A	KEY SW A
34	Empty	
35	Empty	
36	7.5A	KEY SW B
37	7.5A	STOP
38	7.5A	EYE SIGHT

■ Fuse panel located in the engine compartment

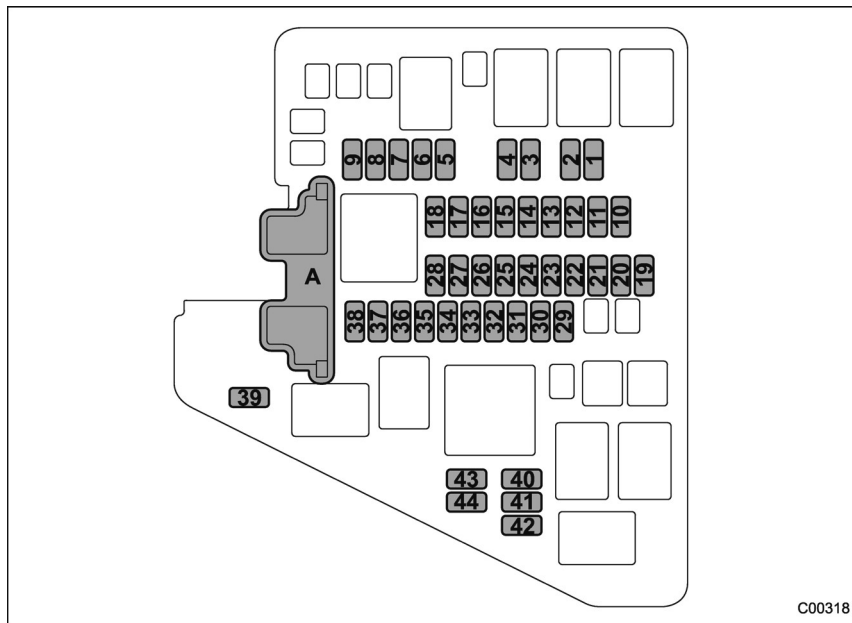

A) Main fuse

C00318

Fuse panel	Fuse rating	Circuit
1	7.5A	HORN 2
2	7.5A	HORN 1
3	15A	H/L LO RH
4	15A	H/L LO LH
5	7.5A	ACTGS
6	10A	H/L HI RH
7	10A	H/L HI LH
8	10A	TAIL
9	10A	ODS
10	7.5A	OBD
11	7.5A	PU B/UP
12	30A	JB-B
13	15A	HAZARD
14	20A	FUEL
15	7.5A	D-OP+B
16	10A	MB-B
17	15A	D/L
18	10A	DCM
19	20A	TCU
20	7.5A	CVT SSR
21	15A	IG COIL
22	10A	AVCS

Fuse panel	Fuse rating	Circuit
23	10A	E/G2
24	Empty	
25	Empty	
26	20A	O2 HTR
27	15A	E/G1
28	Empty	
29	30A	BACKUP
30	25A	R. DEF
31	20A	AUDIO
32	30A	VDC SOL
33	25A	MAIN FAN
34	25A	SUB FAN
35	10A	DEICER
36	15A	F. FOG
37	15A	BLOWER
38	15A	BLOWER
39	Empty	
40	30A	F. WIPER
41	15A	F. WASH
42	15A	R. WIPER
43	Empty	
44	Empty	

Bulb chart

■ Safety precautions



WARNING

Bulbs may become very hot while illuminated. Before replacing bulbs, turn off the lights and wait until the bulbs cool down. Otherwise, there is a risk of sustaining a burn injury.



CAUTION

Replace any bulb only with a new bulb of the specified wattage. Using a bulb of different wattage could result in a fire.

■ Bulb chart

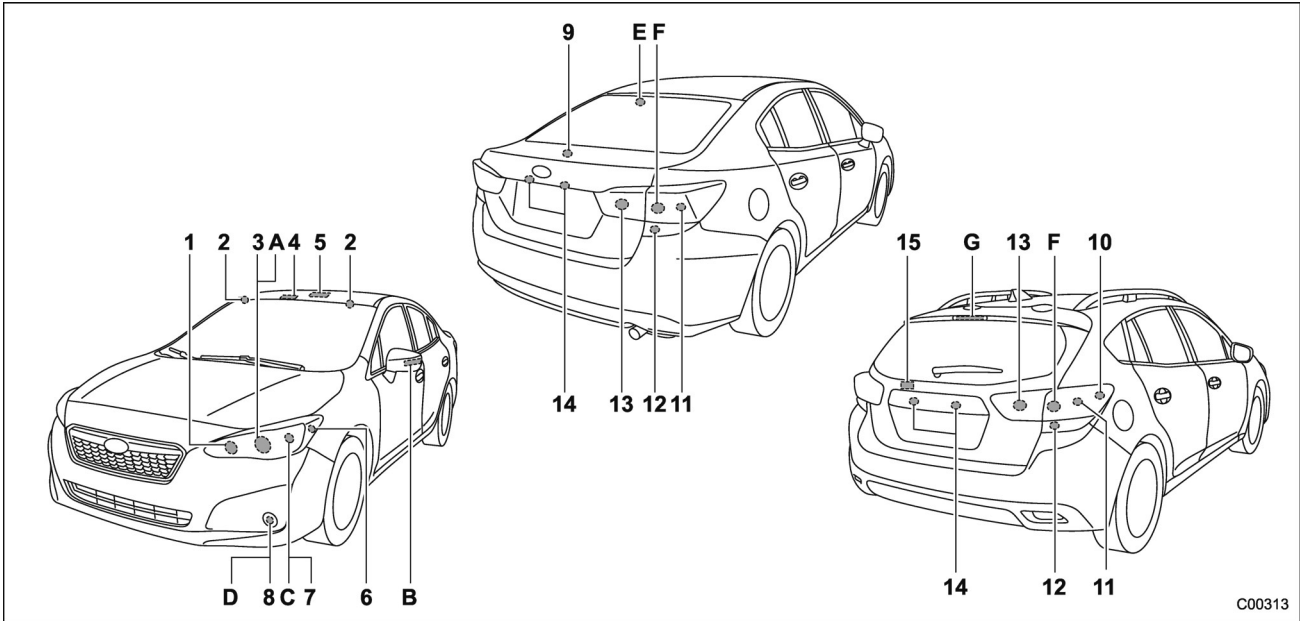

C00313

NOTE

Lights A, B, C, D, E, F and G are the LED (Light Emitting Diode) type. Consult your SUBARU dealer for replacement.

12-16 Specifications/Bulb chart

	Wattage	Bulb No.
1) High beam headlight (models with halogen headlight)	12V-60W	HB3
Front turn signal light (models with LED headlight)	12V-8/28W	7444NA
2) Vanity mirror light (if equipped)	12V-2W	—
3) Low beam headlight (models with halogen headlight)	12V-55W	H11
4) Map light	12V-8W	—
5) Dome light	12V-8W	—
6) Front side marker light	12V-5W	W5W
7) Parking light/Front turn signal light (models with halogen headlight)	12V-5/28W	7444NA
8) Front fog light		
Models without steering responsive fog lights system	12V-19W	H16
Models with steering responsive fog lights system	12V-55W	H11
9) Trunk light (sedan)	12V-3.8W	SAE#194
10) Rear side marker light (5-door models)	12V-5W	W5W
11) Tail light (5-door models)	12V-5W	W5W
Tail and rear side marker light (sedan)	12V-5W	W5W
12) Rear turn signal light	12V-21W	WY21W
13) Backup light	12V-21W	W21W
14) License plate light	12V-5W	W5W
15) Cargo area light (5-door models)	12V-5W	—

	Wattage	Bulb No.
A) Low and high beam headlight (models with LED headlight)	—	—
B) Side turn signal light (if equipped)	—	—
C) Front position light/Daytime running light (models with LED headlight)	—	—
D) Daytime running light (if equipped, models with halogen headlight)	—	—
E) High-mounted stop light (sedan)	—	—
F) Stop light	—	—
G) High-mounted stop light (5-door models)	—	—

Vehicle identification

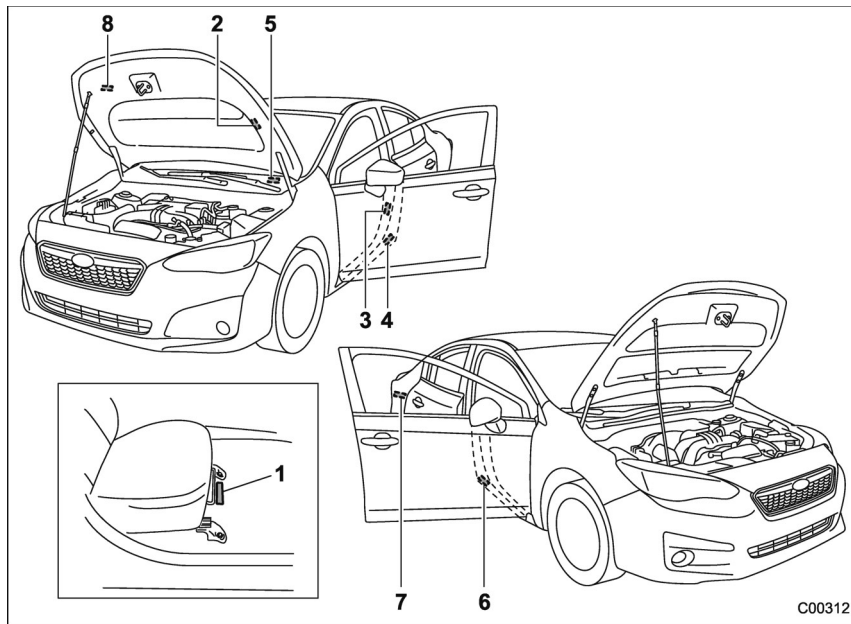

- 1) Vehicle identification number (under the floor carpet of the right-hand front seat)
- 2) Emission control label
- 3) Tire inflation pressure label
- 4) Certification label
- 5) Vehicle identification number plate
- 6) Model number label
- 7) Fuel label
- 8) Air conditioner label

C00312

Consumer information and Reporting safety defects

For U.S.A.	13-2	Steps for Determining Correct Load Limit.....	13-11
Tire information.....	13-2	Vehicle load limit – how to determine.....	13-11
Tire labeling.....	13-2	Calculating total and load capacities varying seating configurations	13-12
Recommended tire inflation pressure.....	13-4	Uniform tire quality grading standards	13-15
Glossary of tire terminology	13-5	Treadwear	13-15
Tire care – maintenance and safety practices.....	13-10	Traction AA, A, B, C.....	13-15
Determining compatibility of tire and vehicle load capacities.....	13-10	Temperature A, B, C.....	13-16
Adverse safety consequences of overloading on handling and stopping and on tires.....	13-10	Reporting safety defects (U.S.A.)	13-16

For U.S.A.

The following information has been compiled according to Code of Federal Regulations "Title 49, Part 575".

Tire information

■ Tire labeling

Many markings (e.g. Tire size, Tire Identification Number or TIN) are placed on the sidewall of a tire by tire manufacturers. These markings can provide you with useful information on the tire.

▼ Tire size

Your vehicle comes equipped with P-Metric tire size. It is important to understand the sizing system in selecting the proper tire for your vehicles. Here is a brief review of the tire sizing system with a breakdown of its individual elements.

▽ P Metric

With the P-Metric system, Section Width is measured in millimeters. To convert millimeters into inches, divide by 25.4. The Aspect Ratio (Section Height divided by Section Width) helps provide more dimensional information about the tire size.

Example:

P **205** / **55** **R** **16**
(1) (2) (3) (4) (5)

- (1) P = Certain tire type used on light duty vehicles such as passenger cars
- (2) Section Width in millimeters
- (3) Aspect Ratio (= section height ÷ section width).
- (4) R = Radial Construction
- (5) Rim diameter in inches

▽ Load and Speed Rating Descriptions

The load and speed rating descriptions will appear following the size designation.

They provide two important facts about the tire. First, the number designation is its load index. Second, the letter designation indicates the tire's speed rating.

Example:

P 205 / 55 R 16 89 V
 Size designation (6) (7)

(6) Load Index: A numerical code which specifies the maximum load a tire can carry at the speed indicated by its speed symbol, at maximum inflation pressure.

For example, "90" means 1,323 lbs (600 kg), "89" means 1,278 lbs (580 kg).

 **WARNING**

Load indices apply only to the tire, not to the vehicle. Putting a load rated tire on any vehicle does not mean the vehicle can be loaded up to the tire's rated load.

(7) Speed Rating: An alphabetical system describing a tire's capability to travel at established and predetermined speeds.

For example, "V" means 149 mph (240 km/h)

 **WARNING**

- **Speed ratings apply only to the tire, not to the vehicle. Putting a speed rated tire on any vehicle does not mean the vehicle can be operated at the tire's rated speed.**
- **The speed rating is void if the tires are worn out, damaged, repaired, retreaded, or otherwise altered from their original condition. If tires are repaired, retreaded, or otherwise altered, they may not be suitable for original equipment tire designed loads and speeds.**

 **Tire Identification Number (TIN)**

Tire Identification Number (TIN) is marked on the intended outboard sidewall. The TIN is composed of four groups. Here is a brief review of the TIN with a breakdown of its individual elements.

DOT XX XX XXX XXXX
 (1) (2) (3) (4)

(1) Manufacturer's Identification Mark

(2) Tire Size

(3) Tire Type Code

(4) Date of Manufacture

The first two figures identify the week, starting with "01" to represent the first full week of the calendar year; the second two figures represent the year. For example, 0101 means the 1st week of 2001.

 **Other markings**

The following markings are also placed on the sidewall.

 **Maximum permissible inflation pressure**

The maximum cold inflation pressure to which this tire may be inflated. For example, "300 kPa (44 PSI) MAX. PRESS"

▽ **Maximum load rating**

The load rating at the maximum permissible weight load for this tire. For example, “MAX. LOAD 580 kg (1279 LBS) @ 300 kPa (44 PSI) MAX. PRESS.”

WARNING

Maximum load rating applies only to the tire, not to the vehicle. Putting a load rated tire on any vehicle does not mean the vehicle can be loaded up to the tire’s rated load.

▽ **Construction type**

Applicable construction of this tire. For example, “TUBELESS STEEL BELTED RADIAL”

▽ **Construction**

The generic name of each cord material used in the plies (both sidewall and tread area) of this tire. For example, “PLIES: TREAD 2

STEEL + 2 POLYESTER SIDE-WALL 2 POLYESTER”

▽ **Uniform Tire Quality Grading (UTQG)**

For details, refer to “Uniform tire quality grading standards” ¶ 13-15.

■ **Recommended tire inflation pressure**

▼ **Recommended cold tire inflation pressure**

For recommended cold tire inflation pressure for your vehicle’s tires, refer to “Tires” ¶ 12-8.

▼ **Vehicle placard**

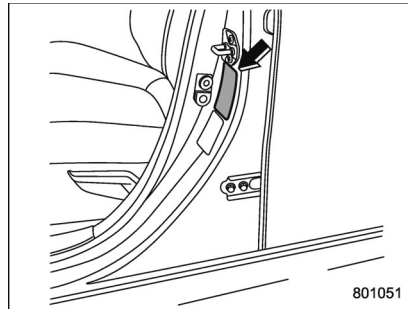

The vehicle placard is attached to the driver’s side door pillar.

Example:

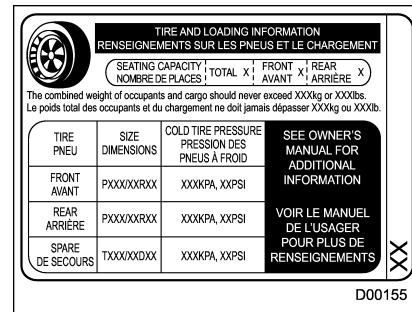

The vehicle placard shows original tire size, recommended cold tire inflation pressure on each tire at maximum loaded vehicle weight, seating capacity and loading information.

▼ **Adverse safety consequences of under-inflation**

Driving at high speeds with excessively low tire pressures can cause the tires to flex severely and to rapidly become hot. A sharp in-

crease in temperature could cause tread separation, and failure of the tire(s). Possible resulting loss of vehicle control could lead to an accident.

▼ **Measuring and adjusting air pressure to achieve proper inflation**

Check and, if necessary, adjust the pressure of each tire (including the spare) at least once a month and before any long journey. Check the tire pressures when the tires are cold. Use a pressure gauge to adjust the tire pressures to the specific values. Driving even a short distance warms up the tires and increases the tire pressures. Also, the tire pressures are affected by the outside temperature. It is best to check tire pressure outdoors before driving the vehicle. When a tire becomes warm, the air inside it expands, causing the tire pressure to increase. Be careful not to mistakenly release air from a warm tire to reduce its pressure.

■ **Glossary of tire terminology**

● **Accessory weight**

The combined weight (in excess of those standard items which may be replaced) of automatic transmission, power steering, power brakes, power windows, power seats, radio, and heater, to the extent that these items are available as factory-installed equipment (whether installed or not).

● **Bead**

The part of the tire that is made of steel wires, wrapped or reinforced by ply cords and that is shaped to fit the rim.

● **Bead separation**

A breakdown of the bond between components in the bead.

● **Bias ply tire**

A pneumatic tire in which the ply cords that extend to the beads are laid at alternate angles substantially less than 90 degrees to the centerline of the tread.

● **Carcass**

The tire structure, except tread and

sidewall rubber which, when inflated, bears the load.

● **Chunking**

The breaking away of pieces of the tread or sidewall.

● **Cold tire pressure**

The pressure in a tire that has been driven less than 1 mile or has been standing for three hours or more.

● **Cord**

The strands forming the plies in the tire.

● **Cord separation**

The parting of cords from adjacent rubber compounds.

● **Cracking**

Any parting within the tread, sidewall, or inner liner of the tire extending to cord material.

● **Curb weight**

The weight of a motor vehicle with standard equipment including the maximum capacity of fuel, oil and coolant, and if so equipped, air conditioning and additional weight optional engine.

- **Extra load tire**

A tire designed to operate at higher loads and higher inflation pressure than the corresponding standard tire.

- **Groove**

The space between two adjacent tread ribs.

- **Innerliner**

The layer(s) forming the inside surface of a tubeless tire that contains the inflating medium within the tire.

- **Innerliner separation**

The parting of the innerliner from cord material in the carcass.

- **Intended outboard sidewall**

(1) The sidewall that contains a whitewall, bears white lettering or bears manufacturer, brand, and/or model name molding that is higher or deeper than the same molding on the other sidewall of the tire, or

(2) The outward facing sidewall of an asymmetrical tire that has a particular side that must always face outward when mount-

ing on a vehicle.

- **Light truck (LT) tire**

A tire designated by its manufacturer as primarily intended for use on lightweight trucks or multipurpose passenger vehicles.

- **Load rating**

The maximum load that a tire is rated to carry for a given inflation pressure.

- **Maximum inflation pressure**

The maximum cold inflation pressure to which a tire may be inflated.

- **Maximum load rating**

The load rating for a tire at the maximum permissible inflation pressure for that tire.

- **Maximum loaded vehicle weight**

The sum of:

- (a) Curb weight
- (b) Accessory weight
- (c) Vehicle capacity weight
- (d) Production options weight

- **Maximum permissible inflation pressure**

The maximum cold inflation pressure to which a tire may be inflated.

- **Measuring rim**

The rim on which a tire is fitted for physical dimension requirements.

- **Normal occupant weight**

150 lbs (68 kg) times the number of occupants specified in the second column of Table 1 that is appended to the end of this section.

- **Occupant distribution**

Distribution of occupants in a vehicle as specified in the third column of Table 1 that is appended to the end of this section.

- **Open splice**

Any parting at any junction of tread, sidewall, or innerliner that extends to cord material.

- **Outer diameter**

The overall diameter of an inflated new tire.

- **Overall width**

The linear distance between the exteriors of the sidewalls of an inflated tire, including elevations due to labeling, decorations, or protective bands or ribs.

- **Passenger car tire**

A tire intended for use on passenger cars, multipurpose passenger vehicles, and trucks, that have a gross vehicle weight rating (GVWR) of 10,000 lbs (4,535 kg) or less.

- **Ply**

A layer of rubber-coated parallel cords.

- **Ply separation**

A parting of rubber compound between adjacent plies.

- **Pneumatic tire**

A mechanical device made of rubber, chemicals, fabric and steel or other materials, that, when mounted on an automotive wheel, provides the traction and contains the gas or fluid that sustains the load.

- **Production options weight**

The combined weight of those installed regular production options weighing over 5.1 lbs (2.3 kg) in excess of those standard items which they replace, not previously considered in curb weight or acces-

sory weight, including heavy duty brakes, ride levelers, roof rack, heavy duty battery, and special trim.

- **Radial ply tire**

A pneumatic tire in which the ply cords that extend to the beads are laid at substantially 90 degrees to the centerline of the tread.

- **Recommended inflation pressure**

The cold inflation pressure recommended by a vehicle manufacturer.

- **Reinforced tire**

A tire designed to operate at higher loads and at higher inflation pressures than the corresponding standard tire.

- **Rim**

A metal support for a tire or a tire and tube assembly upon which the tire beads are seated.

- **Rim diameter**

Nominal diameter of the bead seat.

- **Rim size designation**

Rim diameter and width.

- **Rim type designation**

The industry of manufacturer's designation for a rim by style or code.

- **Rim width**

Nominal distance between rim flanges.

- **Section width**

The linear distance between the exteriors of the sidewalls of an inflated tire, excluding elevations due to labeling, decoration, or protective bands.

- **Sidewall**

That portion of a tire between the tread and bead.

- **Sidewall separation**

The parting of the rubber compound from the cord material in the sidewall.

- **Test rim**

The rim on which a tire is fitted for testing, and it may be any rim listed as appropriate for use with that tire.

- **Tread**

That portion of a tire that comes into contact with the road.

- **Tread rib**

A tread section running circumferentially around a tire.

- **Tread separation**

Pulling away of the tread from the tire carcass.

- **Treadwear indicators (TWI)**

The projections within the principal grooves designed to give a visual indication of the degrees of wear of the tread.

- **Vehicle capacity weight**

The rated cargo and luggage load plus 150 lbs (68 kg) times the vehicle's designated seating capacity.

- **Vehicle maximum load on the tire**

Load on an individual tire that is determined by distributing to each axle its share of the maximum loaded vehicle weight and dividing by two.

- **Vehicle normal load on the tire**

Load on an individual tire that is determined by distributing to each axle its share of the curb weight,

accessory weight, and normal occupant weight (distributed in accordance with Table 1 that is appended to the end of this section) and dividing by 2.

- **Wheel-holding fixture**

The fixture used to hold the wheel and tire assembly securely during testing.

Table 1 — Occupant loading and distribution for vehicle normal load for various designated seating capacities

Designated seating capacity, number of occupants	Vehicle normal load, number of occupants	Occupant distribution in a normally loaded vehicle
2 through 4	2	2 in front.
5 through 10	3	2 in front, 1 in second seat.
11 through 15	5	2 in front, 1 in second seat, 1 in third seat, 1 in fourth seat.
16 through 22	7	2 in front, 2 in second seat, 2 in third seat, 1 in fourth seat.

■ **Tire care – maintenance and safety practices**

- Check on a daily basis that the tires are free from serious damage, nails, and stones. At the same time, check the tires for abnormal wear.
- Inspect the tire tread regularly and replace the tires before their tread wear indicators become visible. When a tire's tread wear indicator becomes visible, the tire is worn beyond the acceptable limit and must be replaced immediately. With a tire in this condition, driving at even low speeds in wet weather can cause the vehicle to hydroplane. Possible resulting loss of vehicle control can lead to an accident.
- To maximize the life of each tire and ensure that the tires wear uniformly, it is best to rotate the tires every 7,500 miles (12,000 km). For information about the tire rotation order, refer to "Tire rotation" ¶ 11-25. Replace any damaged or unevenly worn tires at the time of

rotation. After tire rotation, adjust the tire pressures and make sure the wheel nuts are correctly tightened. For information about the tightening torque and tightening sequence for the wheel nuts, refer to "Flat tires" ¶ 9-6.

■ **Determining compatibility of tire and vehicle load capacities**

The sum of four tires' maximum load ratings must exceed the maximum loaded vehicle weight ("GVWR"). In addition, sum of the maximum load ratings of two front tires and of two rear tires must exceed each axle's maximum loaded capacity ("GAWR"). Original equipment tires are designed to fulfill those conditions.

The maximum loaded vehicle weight is referred to Gross Vehicle Weight Rating (GVWR). And each axle's maximum loaded capacity is referred to Gross Axle Weight Rating (GAWR). The GVWR and each

axle's GAWR are shown on the vehicle certification label located at the bottom of driver's side door pillar.

The GVWR and front and rear GAWRs are determined by not only the maximum load rating of tires but also loaded capacities of the vehicle's suspension, axles and other parts of the body.

Therefore, this means that the vehicle cannot necessarily be loaded up to the tire's maximum load rating on the tire sidewall.

■ **Adverse safety consequences of overloading on handling and stopping and on tires**

Overloading could affect vehicle handling, stopping distance, and vehicle and tire performance in the following ways. This could lead to an accident and possibly result in severe personal injury.

- Vehicle stability will deteriorate.
- Heavy and/or high-mounted

loads could increase the risk of rollover.

- Stopping distance will increase.
- Brakes could overheat and fail.
- Suspension, bearings, axles and other body parts could break or experience accelerated wear that will shorten vehicle life.
- Tires could fail.
- Tread separation could occur.
- Tire could separate from its rim.

■ Steps for Determining Correct Load Limit

1. Locate the statement “The combined weight of occupants and cargo should never exceed XXX kg or XXX lbs.” on your vehicle’s placard.
2. Determine the combined weight of the driver and passengers that will be riding in your vehicle.
3. Subtract the combined weight of the driver and passengers from XXX kg or XXX lbs.
4. The resulting figure equals the available amount of cargo and

luggage load capacity. For example, if the “XXX” amount equals 1400 lbs. and there will be five 150 lb passengers in your vehicle, the amount of available cargo and luggage load capacity is 650 lbs. ($1400 - 750 (5 \times 150) = 650$ lbs.)

5. Determine the combined weight of luggage and cargo being loaded on the vehicle. That weight may not safely exceed the available cargo and luggage load capacity calculated in Step 4.
6. If your vehicle will be towing a trailer, load from your trailer will be transferred to your vehicle. Consult this manual to determine how this reduces the available cargo and luggage load capacity of your vehicle.

Vehicle load limit – how to determine

The load capacity of your vehicle is determined by weight, not by available cargo space. The load limit of your vehicle is shown on the vehicle placard attached to the driver’s side door pillar. Locate the statement “The combined weight of occupants and cargo should never exceed XXX kg or XXX lbs” on your vehicle’s placard.

The vehicle placard also shows seating capacity of your vehicle.

The total load capacity includes the total weight of driver and all passengers and their belongings, any cargo, any optional equipment such as a trailer hitch, roof rack or bike carrier, etc., and the tongue load of a trailer. Therefore cargo capacity can be calculated by the following method.

Cargo capacity = Load limit – (total weight of occupants + total weight

of optional equipment + tongue load of a trailer (if applicable))

For information about vehicle loading, refer to “Loading your vehicle” 8-10.

CAUTION

Your vehicle is neither designed nor intended to be used for trailer towing. Therefore, never tow a trailer with your vehicle.

■ Calculating total and load capacities varying seating configurations

Calculate the available load capacity as shown in the following examples:

Example 1A

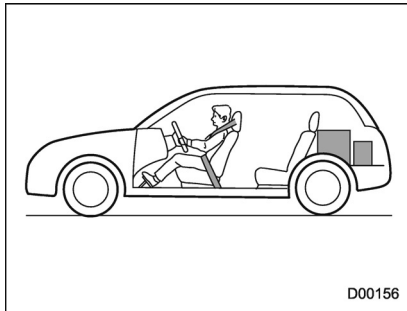

Vehicle capacity weight of the vehicle is 900 lbs (408 kg), which is indicated on the vehicle placard with the statement “The combined weight of occupants and cargo should never exceed 900 lbs or 408 kg”.

For example, if the vehicle has one

occupant weighing 154 lbs (70 kg) plus cargo weighing 662 lbs (300 kg).

1. Calculate the total weight.

Total weight

$$= \frac{154 \text{ lbs (70 kg)}}{\text{(Occupant)}} + \frac{662 \text{ lbs (300 kg)}}{\text{(Cargo)}}$$

$$= \mathbf{816 \text{ lbs (370 kg)}}$$

2. Calculate the available load capacity by subtracting the total weight from the vehicle capacity weight of 900 lbs (408 kg).

Available Load Capacity

$$= \frac{900 \text{ lbs (408 kg)}}{\text{(Vehicle capacity weight)}} - \frac{816 \text{ lbs (370 kg)}}{\text{(Total weight)}}$$

$$= \mathbf{84 \text{ lbs (38 kg)}}$$

3. The result of step 2 shows that a further 84 lbs (38 kg) of cargo can be carried.

Example 1B

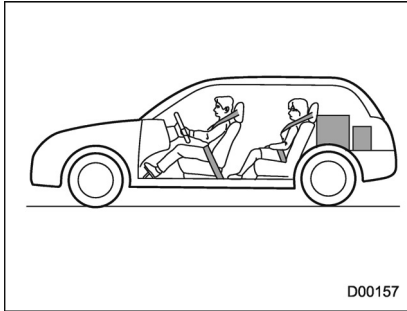

For example, if a person weighing 176 lbs (80 kg) now enters the same vehicle (bringing the number of occupants to two), the calculations are as follows.

1. Calculate the total weight.

Total weight

$$= \frac{154 \text{ lbs (70 kg)} + 176 \text{ lbs (80 kg)}}{\text{(Occupant)}}$$

$$+ \frac{662 \text{ lbs (300 kg)}}{\text{(Cargo)}}$$

$$= \mathbf{992 \text{ lbs (450 kg)}}$$

2. Calculate the available load capacity.

Available Load Capacity

$$= \frac{900 \text{ lbs (408 kg)}}{\text{(Vehicle capacity weight)}} - \frac{992 \text{ lbs (450 kg)}}{\text{(Total weight)}}$$

$$= \mathbf{-92 \text{ lbs (-42 kg)}}$$

3. The total weight now exceeds the capacity weight by 92 lbs (42 kg), so the cargo weight must be reduced by 92 lbs (42 kg) or more.

Example 2A



Your vehicle is neither designed nor intended to be used for trailer towing. Therefore, never tow a trailer with your vehicle.

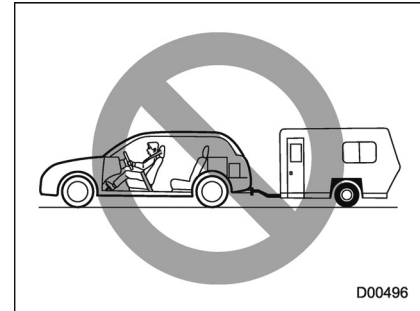

Vehicle capacity weight of the vehicle is 900 lbs (408 kg), which is indicated on the vehicle placard with the statement “The combined weight of occupants and cargo should never exceed 408 kg or 900 lbs”.

For example, the vehicle has one occupant weighing 165 lbs (75 kg) plus cargo weighing 375 lbs (170 kg). In addition, the vehicle is fitted with a trailer hitch weighing 22 lbs (10 kg), to which is attached a trailer weighing 1,764 lbs (800 kg). 10% of the trailer weight is applied to the trailer tongue (i.e. Tongue

load = 176 lbs (80 kg)).

1. Calculate the total weight.

Total weight

$$= \frac{165 \text{ lbs (75 kg)}}{\text{(Occupant)}} + \frac{375 \text{ lbs (170 kg)}}{\text{(Cargo)}}$$

$$+ \frac{22 \text{ lbs (10 kg)}}{\text{(Trailer hitch)}} + \frac{176 \text{ lbs (80 kg)}}{\text{(Tongue load)}}$$

= 738 lbs (335 kg)

2. Calculate the available load capacity.

Available Load Capacity

$$= \frac{900 \text{ lbs (408 kg)}}{\text{(Vehicle capacity weight)}} - \frac{738 \text{ lbs (335 kg)}}{\text{(Total weight)}}$$

= 162 lbs (73 kg)

3. The result of step 2 shows that a further 162 lbs (73 kg) of cargo can be carried.

Example 2B



Your vehicle is neither designed nor intended to be used for trailer towing. Therefore, never tow a trailer with your vehicle.

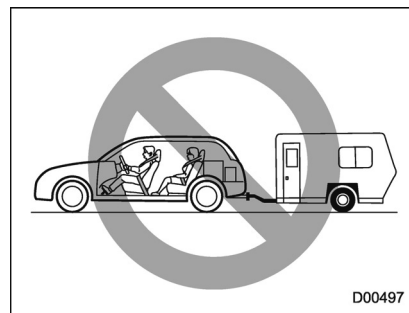

For example, if a person weighing 143 lbs (65 kg) and a child weighing 40 lbs (18 kg) now enter the same vehicle (bringing the number of occupants to three), and a child restraint system weighing 11 lbs (5 kg) is installed in the vehicle for the

child to use, the calculations are as follows.

1. Calculate the total weight.

Total weight

$$= \frac{165 \text{ lbs (75 kg)}}{\text{(Occupant)}} + \frac{143 \text{ lbs (65 kg)}}{\text{(Cargo)}}$$

$$+ \frac{40 \text{ lbs (18 kg)}}{\text{(Occupant)}}$$

$$+ \frac{11 \text{ lbs (5 kg)}}{\text{(Child restraint)}} + \frac{375 \text{ lbs (170 kg)}}{\text{(Cargo)}}$$

$$+ \frac{22 \text{ lbs (10 kg)}}{\text{(Trailer hitch)}} + \frac{176 \text{ lbs (80 kg)}}{\text{(Tongue load)}}$$

= 932 lbs (423 kg)

2. Calculate the available load capacity.

Available Load Capacity

$$= \frac{900 \text{ lbs (408 kg)}}{\text{(Vehicle capacity weight)}} - \frac{932 \text{ lbs (423 kg)}}{\text{(Total weight)}}$$

= -32 lbs (-15 kg)

3. The total weight now exceeds the capacity weight by 32 lbs (15 kg), so the cargo weight must be

reduced by 32 lbs (15 kg) or more.

Uniform tire quality grading standards

This information indicates the relative performance of passenger car tires in the area of treadwear, traction, and temperature resistance. This is to aid the consumer in making an informed choice in the purchase of tires.

Quality grades can be found where applicable on the tire sidewall between tread shoulder and maximum section width.

For example:

Treadwear 200 Traction AA Temperature A

The quality grades apply to new pneumatic tires for use on passenger cars. However, they do not apply to deep tread, winter type snow tires, space-saver or temporary use spare tires, tires with nominal rim diameters of 12 inches or less, or to some limited production tires.

All passenger car tires must conform to Federal Safety Requirements in addition to these grades.

■ Treadwear

The treadwear grade is a comparative rating based on the wear rate of the tire when tested under controlled conditions on a specified government test course.

For example, a tire graded 150 would wear one and one-half (1-1/2) times as well on the government course as a tire graded 100. The relative performance of tires depends upon the actual conditions of their use, however, and may depart significantly from the norm due to variations in driving habits, service practices and differences in road characteristics and climate.

■ Traction AA, A, B, C

The traction grades, from highest to lowest, are AA, A, B and C. Those grades represent the tire's ability to stop on wet pavement as measured

under controlled conditions on specified government test surfaces of asphalt and concrete.

A tire marked C may have poor traction performance.



WARNING

The traction grade assigned to this tire is based on straight-ahead braking traction tests, and does not include acceleration, cornering, hydroplaning, or peak traction characteristics.

■ **Temperature A, B, C**

The temperature grades are A (the highest), B, and C, representing the tire's resistance to the generation of heat and its ability to dissipate heat when tested under controlled conditions on a specified indoor laboratory test wheel.

Sustained high temperature can cause the material of the tire to degenerate and reduce tire life, and

excessive temperature can lead to sudden tire failure.

The grade C corresponds to a level of performance which all passenger car tires must meet under the Federal Motor Vehicle Safety Standards No. 109.

Grades B and A represent higher levels of performance on the laboratory test wheel than the minimum required by law.



WARNING

The temperature grade for this tire is established for a tire that is properly inflated and not overloaded. Excessive speed, underinflation, or excessive loading, either separately or in combination, can cause heat buildup and possible tire failure.

Reporting safety defects (U.S.A.)

If you believe that your vehicle has a defect which could cause a crash or could cause injury or death, you should immediately inform the National Highway Traffic Safety Administration (NHTSA) in addition to notifying Subaru of America, Inc.

If NHTSA receives similar complaints, it may open an investigation, and if it finds that a safety defect exists in a group of vehicles, it may order a recall and remedy campaign. However, NHTSA cannot become involved in individual problems between you, your dealer, or Subaru of America, Inc.

To contact NHTSA, you may call the Vehicle Safety Hotline toll-free at 1-888-327-4236 (TTY: 1-800-424-9153); go to <http://www.safercar.gov>; or write

to: Administrator, NHTSA, 1200
New Jersey Avenue, SE, West
Building, Washington, DC 20590.
You can also obtain other informa-
tion about motor vehicle safety
from <http://www.safercar.gov>.

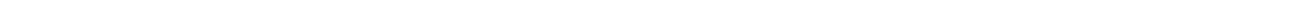
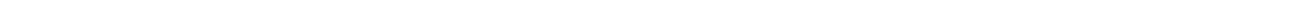
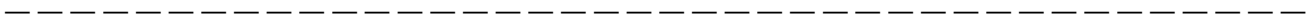
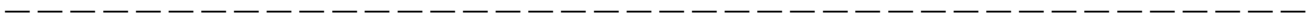
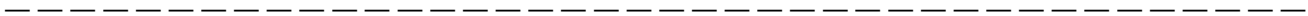

- A**
- Abbreviation 3
 - ABS (Anti-lock Brake System) 7-32
 - Warning light 3-21
 - Access key fob 2-3
 - Warning light 3-25
 - Accessories 11-36
 - Accessory power outlet 6-7
 - Air cleaner element 11-12
 - Air conditioner
 - Automatic climate control 4-6
 - Manual climate control 4-7
 - Air filtration system 4-11
 - Air flow mode 4-7
 - Alarm system 2-26
 - All-Wheel Drive warning light 3-23
 - Aluminum wheel 11-28
 - Cleaning 10-4
 - Antenna 5-2
 - Anti-lock Brake System (ABS) 7-32
 - Arming the system 2-27
 - Ashtray 6-9
 - AT OIL TEMP warning light 3-19
 - Auto on/off headlights 3-66
 - Auto-dimming mirror/compass 3-79, 3-80
 - Automatic headlight beam leveler
 - Warning light 3-32
 - Automatic Locking Retractor/Emergency Locking Retractor (ALR/ELR) 1-13
- B**
- Battery
 - Drainage prevention function 2-26
 - Jump starting 9-10
 - Replacement (access key fob) 11-45
 - Replacement (transmitter) 11-46
 - Vehicle battery 11-34
 - Booster seat 1-32
 - Brake
 - Assist 7-31
 - Booster 7-31, 11-17
 - Disc 12-9
 - Fluid 11-15, 12-7
 - Pad and lining 11-20
 - Parking 7-39, 11-20
 - Pedal 11-18
 - System 7-31
 - Brake system 7-31
 - Warning light 3-21
 - Braking 7-30
 - Tips 7-30
 - Breaking-in of new brake pads and linings 11-20
 - BSD/RCTA 7-48
 - Approach indicator light/warning buzzer 7-52
 - OFF indicator 3-33
 - OFF switch 7-54
 - Warning indicator 3-33, 7-53
 - Warning volume 7-52
 - Bulb
 - Chart 12-14
 - Replacement 11-37

C

- Cargo area
 - Cover 6-11
 - Light 6-3, 11-44
 - Tie-down hooks 6-13
- Catalytic converter 8-3
- Center console 6-6
- Changing
 - Coolant 11-12
 - Flat tire 9-6
 - Oil and oil filter 11-9
- Charge warning light 3-18
- CHECK ENGINE warning light/Malfunction indicator light 3-16
- Checking
 - Brake pedal free play 11-18
 - Brake pedal reserve distance 11-18
 - Clutch function 11-18
 - Clutch pedal free play 11-19
 - Coolant level 11-11
 - Fluid level (brake fluid) 11-15
 - Fluid level (clutch fluid) 11-16
 - Fluid level (washer fluid) 11-29
 - Oil level (engine oil) 11-8
- Child restraint systems 1-25
 - Installation of a booster seat 1-32
 - Installation with ALR/ELR seatbelt 1-28
 - Lower and tether anchorages 1-33
 - Top tether anchorages 1-36
- Child safety 5
 - Locks 2-30
- Chime
 - Key 3-5
 - Light 3-66
 - Seatbelt 3-14
- Cigarette lighter 6-8
- Cleaning
 - Aluminum wheels 10-4
 - Interior 10-5
 - Ventilation grille 4-10
- Climate control system 4-2
 - Automatic 4-6
 - Manual 4-7
- Clock 3-48, 3-52, 3-63
- Clutch
 - Fluid 11-16
 - Pedal 11-18
- Coat hook 6-10
- Combination meter display (color LCD) 3-34
- Compass 3-79, 3-80
- Continuously variable transmission (CVT) 7-23
 - Fluid 11-15, 12-7
 - Oil temperature warning light (AT OIL TEMP) 3-19
- Coolant 11-11, 12-7
 - Temperature high warning light 3-17
 - Temperature low indicator light 3-17
- Cooling system 11-10
- Corrosion protection 10-4
- Cruise control 7-44
 - Indicator light 3-32
 - Set indicator light 3-32

- D**
- Daytime running light system..... 3-71
 - Defogger..... 3-88
 - Defrosting 4-10
 - Deicer 3-88
 - Differential gear oil
 - Front 11-15, 12-6
 - Rear..... 11-15, 12-6
 - Dimensions 12-2
 - Disarming the alarm system 2-28
 - Disc brake pad wear warning indicators 7-32
 - Dome light 6-2, 11-44
 - Door
 - Locks 2-23
 - Open warning light..... 3-23
 - Unlock selection function 3-43
 - Drive belts..... 11-14
 - Driving
 - AWD vehicles 8-4
 - Drinking 6
 - Drugs 6
 - Foreign countries 8-4
 - Pets 7
 - Snowy and icy roads 8-7
 - Tips..... 7-22, 7-29, 8-2, 8-4
 - Tired or sleepy..... 7
 - Winter 8-6
- E**
- ECO gauge..... 3-11
 - Electrical system..... 12-8
 - Electronic Brake Force Distribution (EBD) system..... 7-33
 - Warning 3-22
 - Emergency Locking Retractor (ELR) 1-13
 - Engine
 - Compartment overview..... 11-7
 - Coolant 11-11, 12-7
 - Exhaust gas (carbon monoxide) 6, 8-2
 - Hood 11-5
 - Low oil level warning light..... 3-18
 - Oil 11-8, 12-4
 - Overheating 9-13
 - Starting & stopping 7-9, 7-12
 - Event data recorder 9
 - Exterior care 10-2
- F**
- Flat tires 9-6
 - Floor mat..... 6-10
 - Fluid level
 - Brake..... 11-15
 - Clutch 11-16
 - Continuously variable transmission 11-15
 - Fog light
 - Bulb..... 11-39, 12-14
 - Indicator light 3-32
 - Switch..... 3-73
 - Front
 - Differential gear oil..... 11-15, 12-6
 - Seatbelt pretensioners 1-20
 - Turn signal light..... 11-39
 - Fuel..... 7-3

Consumption indicator	3-44
Economy hints	8-2
Filler lid and cap	7-4
Gauge	3-10
Requirements	7-3, 12-3
Fuses	11-35
Fuses and circuits	12-10

G

GAWR (Gross Axle Weight Rating)	8-11
Glove box	6-5
GVWR (Gross Vehicle Weight Rating)	8-11

H

Hazard warning flasher	3-8, 9-2
Headlight	
Beam leveler	3-73
Bulb replacing	11-37
Bulb wattage	12-14
Control switch	3-66
Flasher	3-68
Indicator light	3-32
Welcome lighting function	3-66
High Beam Assist	3-68
High beam assist function	3-68
Indicator light	3-31
Warning indicator	3-31
High beam indicator light	3-31
High/low beam change (dimmer)	3-68
Hill start assist	7-41, 11-19
OFF indicator light	3-23

Warning light	3-23
HomeLink®	3-80
Hook	
Cargo tie-down	6-13
Coat	6-10
Shopping bag	6-11
Towing and tie-down	9-14
Horn	3-91
Hose and connections	11-11

I

Ignition switch	3-4
Light	3-5
Illumination brightness control	3-12
Immobilizer	2-17
Indicator light (security indicator light)	3-30
Indicator light	
BSD/RCTA OFF	3-33, 3-36
BSD/RCTA warning	3-33, 3-36
Coolant temperature low	3-17
Cruise control	3-32
Cruise control set	3-32
Front fog light	3-32
Headlight	3-32
High beam	3-31
High beam assist	3-31
High beam assist warning	3-31
Hill start assist OFF	3-23
Immobilizer	3-30
Security	3-30
Select lever/Gear position	3-31

Steering responsive fog lights OFF.....	3-32
Turn signal.....	3-31
Vehicle Dynamics Control OFF.....	3-25
Vehicle Dynamics Control operation.....	3-24
Inside mirror.....	3-79
Interior lights.....	6-2
Internal trunk lid release handle.....	2-34

J

Jack-up point.....	9-6
Jump starting.....	9-10

K

Key.....	2-3
Number plate.....	2-3
Reminder chime.....	3-5
Replacement.....	2-18
Keyless access with push-button start system.....	2-3
Disabling keyless access functions.....	2-14
Warning chimes and warning indicator.....	3-25
When access key fob does not operate properly.....	9-18
Keyless entry system.....	2-19

L

Lap belt pretensioner.....	1-22
Leather seat materials.....	10-6
License plate light.....	11-43
Light	
Backup.....	11-41
Cargo area.....	6-3, 11-44
Control switch.....	3-66

Daytime running.....	3-71
Dome.....	6-2, 11-44
Front fog.....	3-73, 11-39
Front side marker.....	3-66, 12-14
Ignition switch.....	3-5
License plate.....	11-43
Map.....	6-2, 11-44
Parking.....	11-39
Rear combination.....	11-39
Rear side marker light.....	11-39
Stop.....	11-39
Tail.....	11-39
Trunk.....	11-44
Turn signal.....	3-75, 11-39
Vanity mirror.....	6-5, 11-44
Loading your vehicle.....	8-10
Low fuel warning light.....	3-22
Low tire pressure warning light.....	3-19
Lower and tether anchorage.....	1-33

M

Maintenance	
Precautions.....	11-3
Schedule.....	11-3
Seatbelt.....	1-20
Tools.....	9-3
Malfunction indicator light (check engine warning light)....	3-16
Manual	
Transmission.....	7-21
Transmission oil.....	11-14
Manual mode.....	7-26

Map light.....	6-2, 11-44
Meters and gauges	3-9
Mirror defogger	3-88
Mirrors.....	3-79
Moonroof	2-37, 9-20
Multi-function display (black and white).....	3-43
Multi-function display (color LCD).....	3-48

N

New vehicle break-in driving.....	8-2
-----------------------------------	-----

O

Odometer.....	3-9
Oil filter.....	11-9
Oil level	
Engine.....	11-8
Front differential gear	11-15
Rear differential gear.....	11-15
Warning light	3-18
Oil pressure warning light.....	3-18
Outside	
Mirror defogger.....	3-88
Mirrors.....	3-87
Temperature indicator	3-47, 3-51
Overheating engine.....	9-13

P

Parking	
Brake	7-39
Brake stroke.....	11-20
Light.....	11-39

Tips	7-39
Periodic inspections.....	8-4
Petrol fuel.....	7-3
Power	
Outlets.....	6-7
Outside mirrors	3-88
Steering	7-29
Steering warning light.....	3-23
Windows	2-30
Precautions against vehicle modification.....	1-24, 1-68
Preparing to drive.....	7-8
Push-button	
Ignition switch	3-6
Starting and stopping engine.....	7-9, 7-12

R

RAB (Reverse Automatic Braking)	
OFF indicator.....	3-33
Warning indicator.....	3-33
Rear	
Combination lights	11-39
Differential gear oil.....	11-15, 12-6
Gate	2-35, 9-20
Turn signal light.....	11-39
Rear window	
Defogger	3-88
Wiper and washer switch.....	3-78
Wiper blades.....	11-32

- Recommended
 - Brake fluid..... 12-7
 - Continuously variable transmission fluid..... 12-7
 - Engine oil..... 12-4
 - Front differential gear oil..... 12-6
 - Rear differential gear oil..... 12-6
 - Spark plugs..... 12-8
 - Refueling..... 7-5
 - Remote engine start system..... 7-15
 - Remote keyless entry system..... 2-19
 - Replacement
 - Access key fob battery..... 11-45
 - Air cleaner element..... 11-13
 - Brake pad and lining..... 11-19
 - Lost transmitters (remote keyless entry system)..... 2-22
 - Remote keyless entry transmitter battery..... 11-46
 - Wiper blades..... 11-30
 - Replacing bulbs..... 11-37, 12-14
 - Backup light..... 11-41
 - Cargo area light..... 11-44
 - Dome light..... 11-44
 - Front fog light..... 11-39
 - Front turn signal light..... 11-39
 - Halogen headlight..... 11-37
 - Headlight..... 11-37
 - License plate light..... 11-43
 - Map light..... 11-44
 - Parking light..... 11-39
 - Rear combination light..... 11-39
 - Rear side marker light..... 11-39
 - Rear turn signal light..... 11-39
 - Stop light..... 11-39
 - Tail light..... 11-39
 - Trunk light..... 11-44
 - Vanity mirror light..... 11-44
 - Rocking the vehicle..... 8-9
 - Roof molding and crossbar..... 8-12
 - Roof rails..... 8-12
- S**
- Safety
 - Precautions when driving..... 4
 - Symbol..... 3
 - Warnings..... 2
 - Seat
 - Fabric..... 10-5
 - Heater..... 1-10
 - Seatbelt..... 4, 1-11
 - Fastening..... 1-14
 - Maintenance..... 1-20
 - Pretensioners..... 1-20
 - Safety tips..... 1-11
 - Warning light and chime..... 3-14
 - Security
 - Alarm system..... 2-26
 - Immobilizer..... 2-17
 - Indicator light..... 3-30
 - Select lever
 - Position indicator..... 3-31
 - Shift lock function..... 7-28
 - Shopping bag hook..... 6-11
 - Shoulder pretensioners..... 1-21

Snow tires.....	8-8, 11-21
Snowy and icy roads.....	8-7
Sounding a panic alarm.....	2-21
Spark plugs.....	11-14, 12-8
Specifications.....	12-2
Speedometer.....	3-9
SRS	
Curtain airbag.....	1-58
Frontal airbag.....	1-47
Side airbag.....	1-58
SRS airbag (Supplemental Restraint System airbag) ...	4, 1-38
SRS airbag system	
Monitors.....	1-66
Servicing.....	1-67
Warning light.....	3-15
Starting & stopping engine.....	7-9, 7-12
State emission testing (U.S. only).....	7-7
Steering responsive fog lights system.....	3-73
OFF indicator.....	3-32
Steering Responsive Headlight.....	3-72
Steering wheel	
Heater.....	3-90
Power.....	7-29
Tilt/telescopic.....	3-90
Stop light.....	11-39
Storage compartment.....	6-5
Sun shade.....	2-39
Sun visors.....	6-3
Supplemental Restraint System airbag (SRS).....	1-38
Synthetic leather upholstery.....	10-6

T

Tachometer.....	3-9
Temperature warning light	
AT OIL TEMP.....	3-19
Coolant.....	3-17
Temporary spare tire.....	9-2, 12-9
Tether (child restraint system).....	1-33, 1-36
Tie-down hooks/holes.....	9-14
Tire.....	11-21, 12-8
Chains.....	8-9
Inspection.....	11-22
Pressures and wear.....	11-23
Replacement.....	11-26
Rotation.....	11-25
Size and pressure.....	12-8
Types.....	11-21
Tire pressure monitoring system (TPMS).....	7-37, 9-9, 11-21
Warning light.....	3-19
Tires and wheels.....	11-21
Tools.....	9-3
Top tether anchorages.....	1-33, 1-36
Towing.....	9-14
All wheels on the ground.....	9-17
Flat-bed truck.....	9-16
Hooks.....	9-14
Trailer towing.....	8-14
Trip meter.....	3-9
Trunk lid.....	2-33
Release handle.....	2-34
Trunk light.....	11-44

- Turn signal
Indicator lights 3-31
Lever 3-75
- U**
- Under-floor storage compartment 6-14
- V**
- Valet mode 2-29
Vanity mirror 6-4, 11-44
Light 11-44
- Vehicle
Capacity weight 8-10
Identification 12-18
Symbols 4
- Vehicle Dynamics Control
OFF indicator light 3-25
OFF switch 7-36
Operation indicator light 3-24
System 7-34
Warning light 3-24
- Ventilator 4-2
- W**
- Warning and indicator lights 3-13
Warning chimes
Keyless access with push-button start system 3-25
Seatbelt 3-14
- Warning light
ABS 3-21
Access key 3-25
- All-Wheel Drive 3-23
AT OIL TEMP 3-19
Automatic headlight beam leveler 3-32
Brake system 3-21
BSD/RCTA 3-33
Charge 3-18
CHECK ENGINE 3-16
Coolant temperature high 3-17
Door open 3-23
Engine low oil level 3-18
High beam assist 3-31
Hill start assist 3-23
Icy road surface 3-33
Keyless access with push-button start system 3-25
LED headlight 3-32
Low fuel 3-22
Low tire pressure 3-19
Oil pressure 3-18
Power steering 3-23
RAB 3-33
Seatbelt 3-14
SRS airbag system 3-15
Steering responsive fog lights 3-32
Steering Responsive Headlight 3-32
Vehicle Dynamics Control 3-24
Windshield washer fluid 3-19
- Warranties 1
Washing 10-2
Waxing and polishing 10-3
Wear indicators 11-25
Welcome lighting function 3-66

Wheel	
Aluminum.....	11-28
Balance	11-24
Covers.....	11-27
Nut tightening torque	12-8, 12-9
Replacement	11-27
Windows	2-30
Windshield	
Washer fluid	11-29
Wiper and washer switches.....	3-77
Wiper blades	11-30
Wiper deicer.....	3-88
Winter	
Driving.....	8-6
Tires.....	8-8, 11-21
Wiper and washer.....	3-75
Wiper deicer.....	3-88

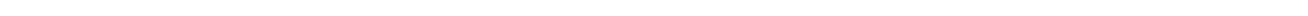
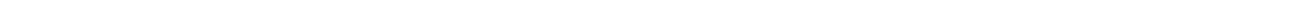
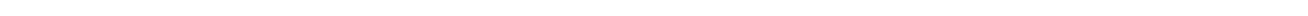
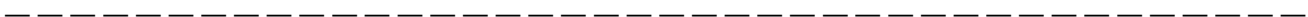
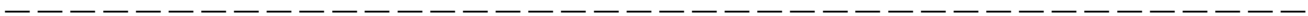
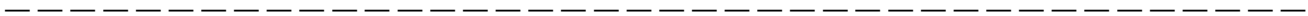

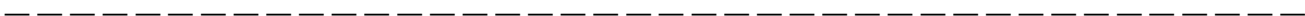
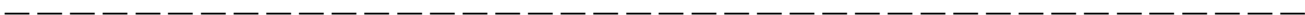
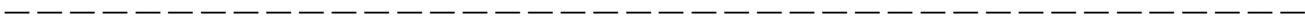
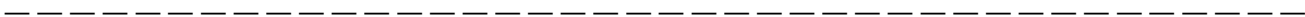
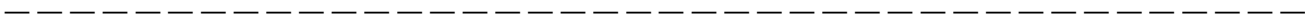
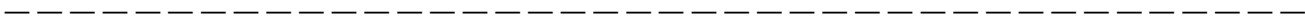
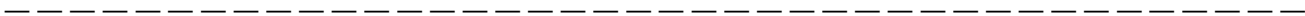
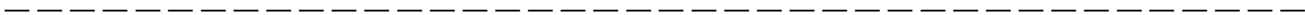

GAS STATION REFERENCE

■ Fuel:

Use only **unleaded gasoline** with an octane rating of **87 AKI (90 RON) or higher**.

■ Fuel octane rating:

▼ RON

This octane rating is the Research Octane Number.

▼ AKI

This octane rating is the average of the Research Octane and Motor Octane numbers and is commonly referred to as the Anti Knock Index (AKI).

■ Fuel capacity:

13.2 US gal (50 liters, 11.0 Imp gal)

■ Engine oil:

Use only the following oils.

- API classification SN with the words “RESOURCE CONSERVING”
- or ILSAC GF-5, which can be identified with the ILSAC certification mark (Starburst mark)

For the complete viscosity requirements, refer to “Engine oil” [☞12-4](#).

■ Engine oil capacity:

4.7 US qt (4.4 liters, 3.9 Imp qt)

The indicated oil quantity is only a guideline and is estimated based on a case when the engine oil is changed with an oil filter. After refilling the engine with oil, the oil level should be checked using the oil level gauge. For more details about maintenance and service, refer to “Engine oil” [☞11-8](#).

■ Cold tire pressure:

Refer to “Tires” [☞12-8](#).