

---

## Important safety notice

---

- Providing appropriate service and repair is a matter of great importance in the serviceman's safety maintenance and safe operation, function and performance which the SUBARU vehicle possesses.
- In case the replacement of parts or replenishment of consumables is required, genuine SUBARU parts whose parts numbers are designated or their equivalents must be utilized.
- It must be made well known that the safety of the serviceman and the safe operation of the vehicle would be jeopardized if the used any service parts, consumables, special tools and work procedure manuals which are not approved or designated by SUBARU.

All right reserved. This book may not be reproduced or copied, in whole or in part, without the written permission of FUJI HEAVY INDUSTRIES LTD., TOKYO JAPAN.

SUBARU,  and  are trademarks of FUJI HEAVY INDUSTRIES LTD.

© Copyright 1994 FUJI HEAVY INDUSTRIES LTD.

---

## How to use this manual

---

- This Service Manual is divided into four volumes by section so that it can be used with ease at work. Refer to the Table of Contents, select and use the necessary section.

- GENERAL INFORMATION SECTION
- REPAIR SECTION
- TROUBLESHOOTING SECTION
- WIRING DIAGRAM SECTION

- Each chapter in the manual is basically made of the following four types of areas.

- S SPECIFICATIONS AND SERVICE DATA
- C COMPONENT PARTS
- W SERVICE PROCEDURE
- (X SERVICE PROCEDURE)
- (Y SERVICE PROCEDURE)
- K DIAGNOSTICS

- The description of each area is provided with four types of titles different in size as shown below. The Title No. or Symbol prefixes each title in order that the construction of the article and the flow of explanation can be easily understood.

[Example of each title]

- Area title: W SERVICE PROCEDURE (one of the four types of areas)
- Large title (Heading): 1. Oil Pump (to denote the main item of explanation)
- Medium title (Section): A: REMOVAL (to denote the type of work in principle)
- Small title (Sub-section): 1. INNER ROTATOR (to denote a derivative item of explanation)

- The Title Index No. is indicated on the top left (or right) side of the page as the book is opened. This is useful for retrieving the necessary portion.

(Example of usage)

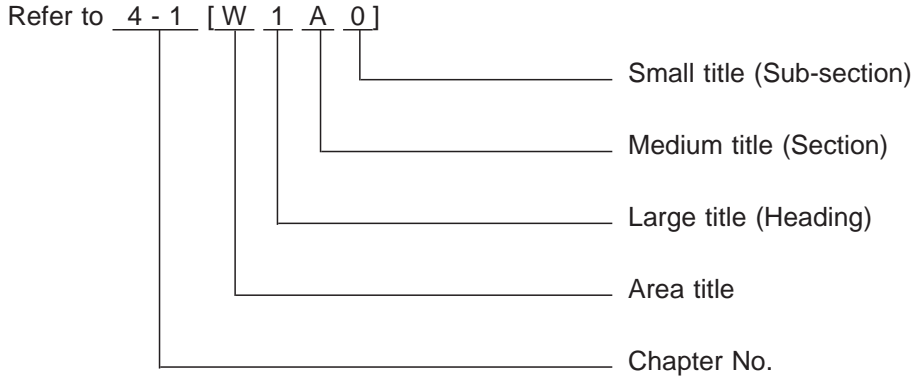

Medium title      Large title      Title index No.      Example of title placement

**SERVICE PROCEDURE**

---

[W1A2] 4-1  
1. On-car Service

**1. On-car Service**  
**A: WHEEL ALIGNMENT**  
Check adjust and/or measure wheel alignment in accordance with procedures indicated below:

**1. WHEEL ARCH HEIGHT**

↓

**2. CAMBER & CASTER**

↓

**3. REAR TOE-IN**

↓

**4. THRUST ANGLE**

↓

**5. FRONT TOE-IN**

↓

**6. STEERING ANGLE**

M4A0056

Wheel arch height

**1. WHEEL ARCH HEIGHT**

- 1) Inflate tire pressure to specifications.
- 2) Set vehicle under "curb weight" conditions. (Empty luggage compartment, install spare tire, jack, service tools, and top up fuel tank).
- 3) Set steering wheel in a wheel-forward position.
- 4) Suspend thread from wheel arch to determine a point directly above center of spindle.
- 5) Measure distance between measuring point and center of spindle.

Small title

- In this manual, the following symbols are used.

\* : Selective part

★ : Replacement part

 : Should be lubricated with oil.

 : Should be lubricated with grease.

 : Sealing point

 : Tightening torque

- WARNING, CAUTION, NOTE

- **WARNING:** Indicates the item which must be observed precisely during performance of maintenance services in order to avoid injury to the mechanics and other persons.
- **CAUTION:** Indicates the item which must be followed precisely during performance of maintenance services so as to avoid damage and breakage to the vehicle and its parts and components.
- **NOTE:** Indicates the hints, knacks, etc. which make the maintenance job easier.

- **SPECIAL TOOLS**

When any special tool is required to perform the job, it is identified by “ST” in the applicable illustration and its part number is shown in the manual.

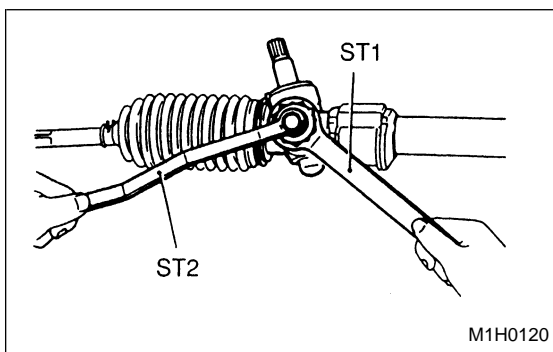

## 1. Procedures for adjusting backlash

- 1) Set steering wheel to the straight-ahead position.
- 2) Remove the exhaust pipe
- 3) Loosen the lock nut with ST. ←

{	ST1	921650000	STEERING GEARBOX WRENCH
{	ST2	921550000	STEERING GEARBOX WRENCH

Description  
(of job method)

Shows the part name

Shows the part number

Tells that two kinds of special tools are required.  
When two or more kinds of special tools are required to do a job, they are identified by ST1, ST2,.....respectively.

## 1. Front Catalytic Converter

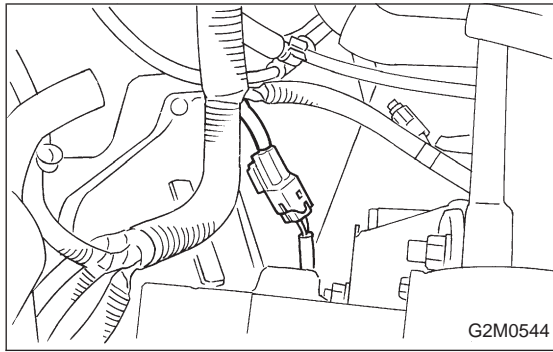

## 1. Front Catalytic Converter

## A: REMOVAL

1) Disconnect front oxygen sensor connector.

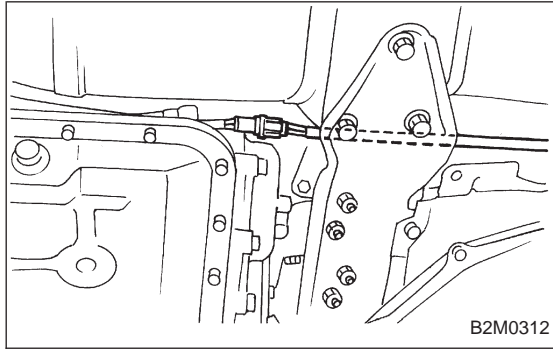

2) Lift-up the vehicle.

3) Disconnect rear oxygen sensor connector.

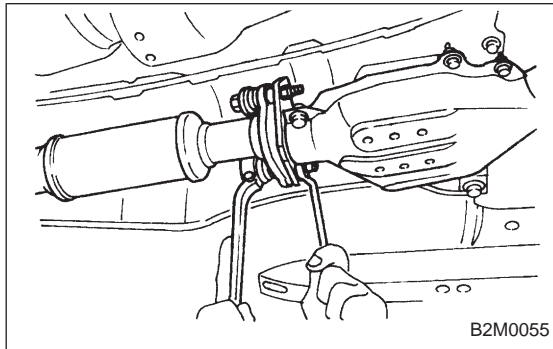

4) Separate center exhaust pipe from rear exhaust pipe.

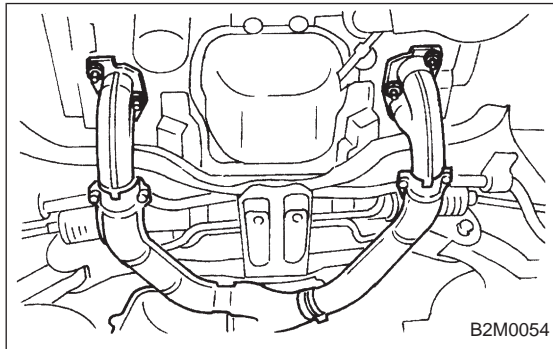

5) Remove bolts which hold front exhaust pipe onto cylinder heads.

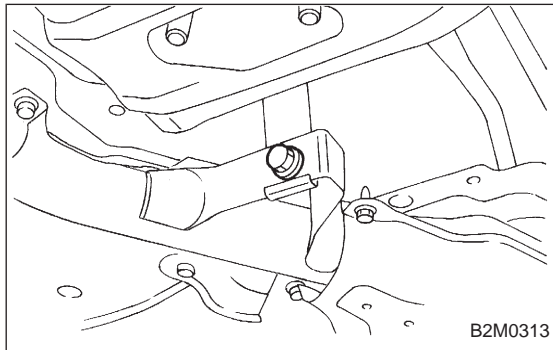

6) Remove front exhaust pipe and center exhaust pipe from hanger bracket.

**CAUTION:**

**Be careful not to pull down front exhaust pipe and center exhaust pipe.**

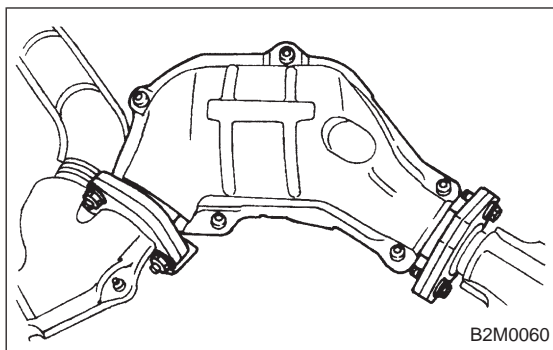

7) Separate front catalytic converter from front exhaust pipe and center exhaust pipe.

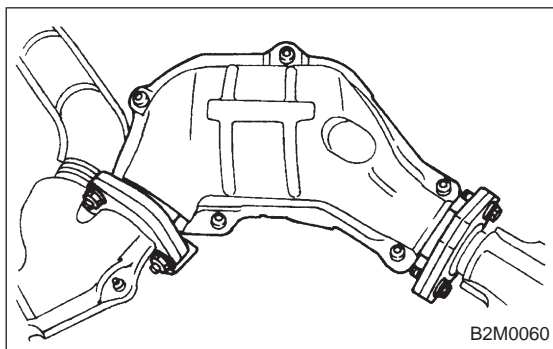

**B: INSTALLATION**

**CAUTION:**

Replace gaskets with new ones.

1) Install front catalytic converter to front exhaust pipe and center exhaust pipe.

**Tightening torque:**

**$30\pm 5$  N·m ( $3.1\pm 0.5$  kg·m,  $22.4\pm 3.6$  ft·lb)**

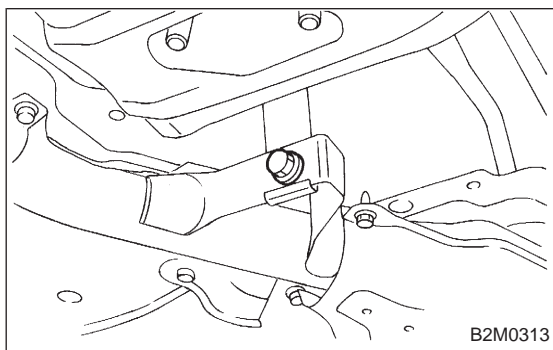

2) Install front exhaust pipe and center exhaust pipe. And temporarily tighten bolt which installs center exhaust pipe to hanger bracket.

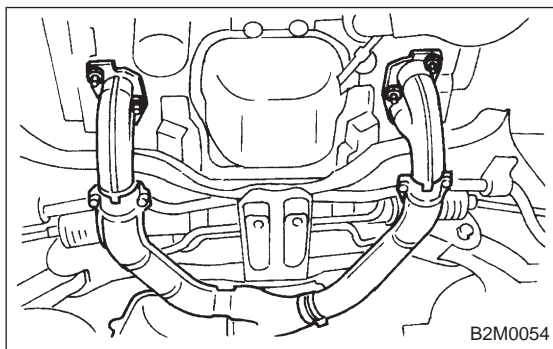

3) Tighten bolts which hold front exhaust pipe onto cylinder heads.

**Tightening torque:**

**$30\pm 5$  N·m ( $3.1\pm 0.5$  kg·m,  $22.4\pm 3.6$  ft·lb)**

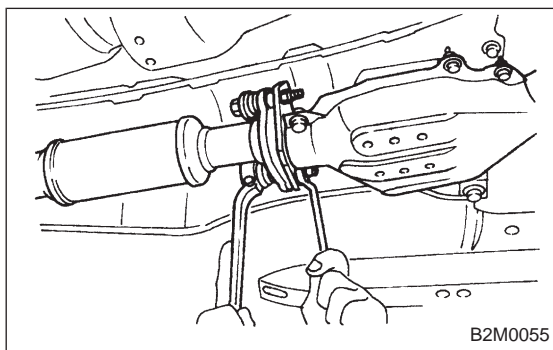

4) Install center exhaust pipe to rear exhaust pipe.

**Tightening torque:**

**$18\pm 5$  N·m ( $1.8\pm 0.5$  kg·m,  $13.0\pm 3.6$  ft·lb)**

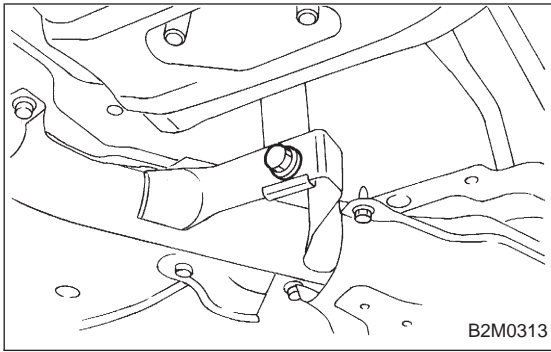

5) Tighten bolt which holds center exhaust pipe to hanger bracket.

**Tightening torque:**

**$35\pm 5$  N·m ( $3.6\pm 0.5$  kg-m,  $26.0\pm 3.6$  ft-lb)**

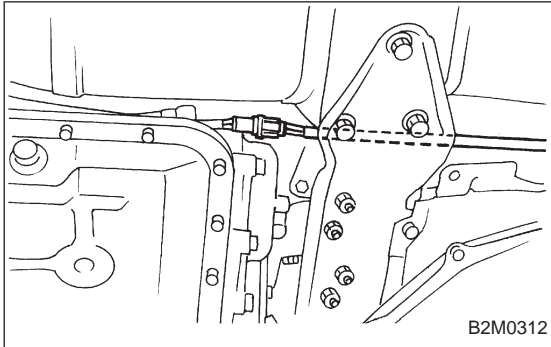

6) Connect rear oxygen sensor connector.

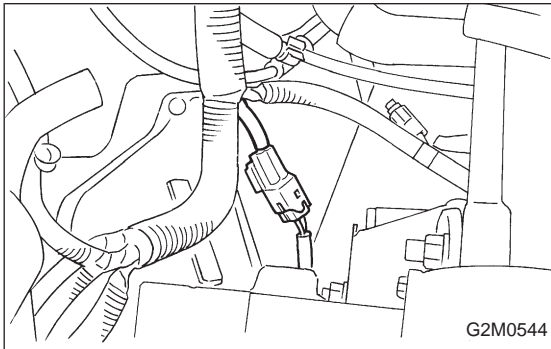

7) Lower the vehicle.

8) Connect front oxygen sensor connector.

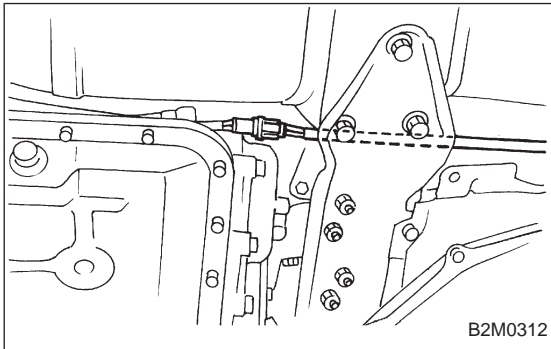

## 2. Rear Catalytic Converter

### A: REMOVAL

1) Lift-up the vehicle.

2) Disconnect rear oxygen sensor connector.

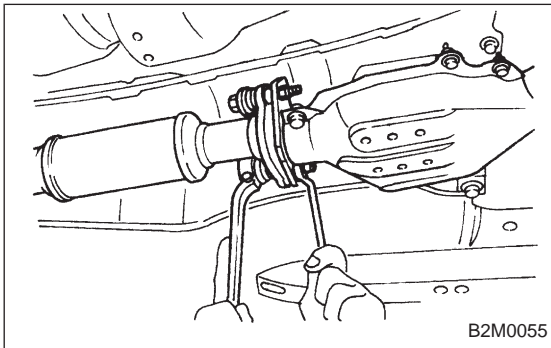

3) Separate center exhaust pipe and rear catalytic converter assembly from rear exhaust pipe.

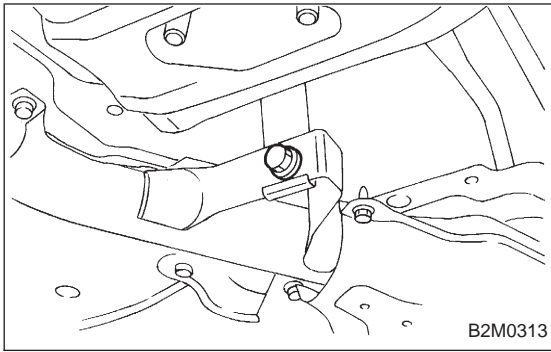

5) Tighten bolt which holds center exhaust pipe to hanger bracket.

**Tightening torque:**

**$35\pm 5$  N·m ( $3.6\pm 0.5$  kg-m,  $26.0\pm 3.6$  ft-lb)**

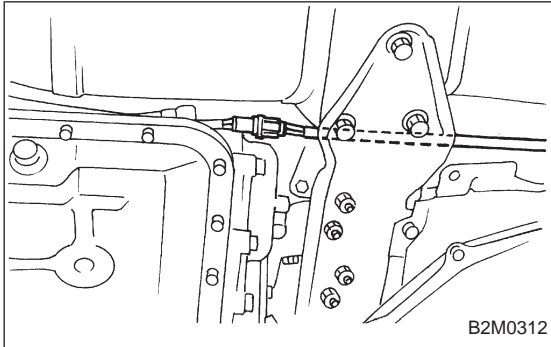

6) Connect rear oxygen sensor connector.

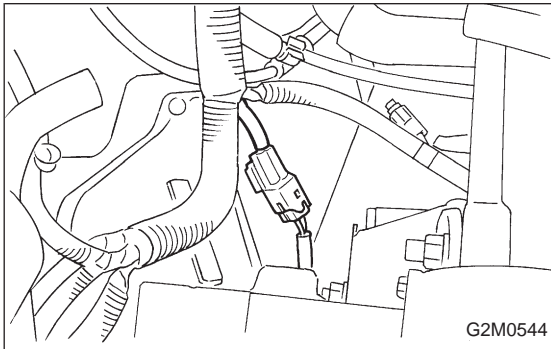

7) Lower the vehicle.

8) Connect front oxygen sensor connector.

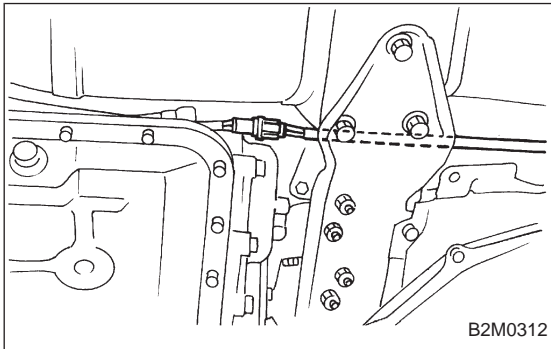

## 2. Rear Catalytic Converter

### A: REMOVAL

1) Lift-up the vehicle.

2) Disconnect rear oxygen sensor connector.

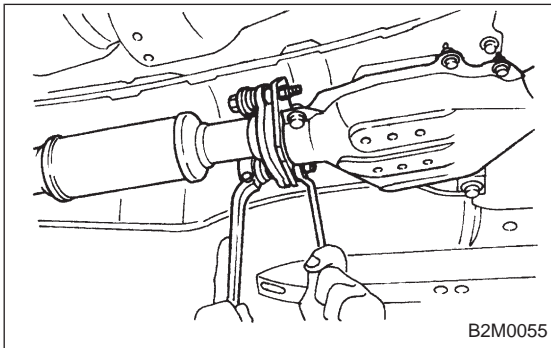

3) Separate center exhaust pipe and rear catalytic converter assembly from rear exhaust pipe.



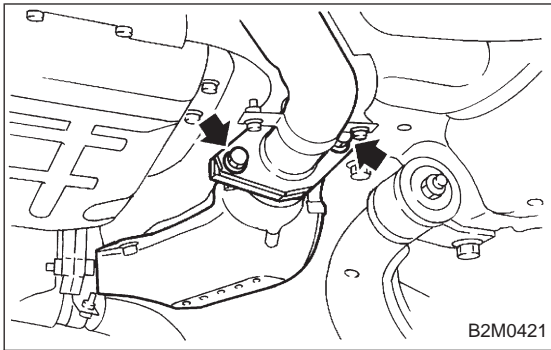

4) Separate center exhaust pipe and rear catalytic converter assembly from front catalytic converter.

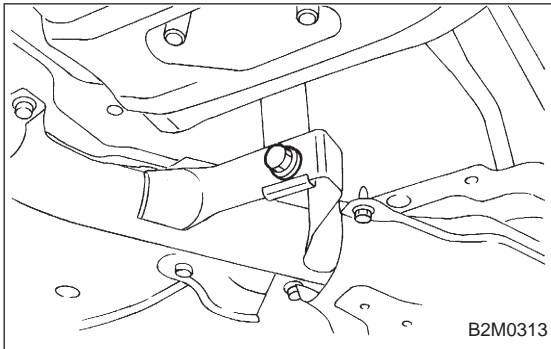

5) Remove center exhaust pipe and rear catalytic converter assembly from hanger bracket.

**CAUTION:**

- Be careful not to pull down center exhaust pipe.
- After removing center exhaust pipe, do not apply excessive pulling force on front catalytic converter and front exhaust pipe.

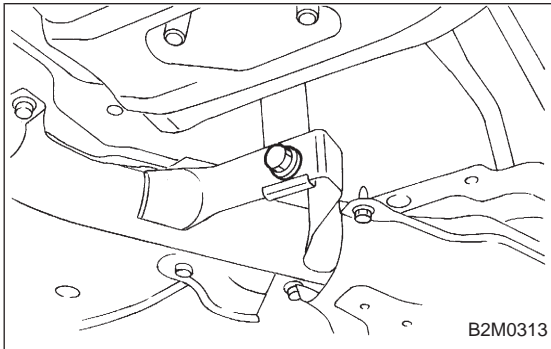

**B: INSTALLATION**

**CAUTION:**

Replace gaskets with new ones.

1) Install center exhaust pipe and rear catalytic converter assembly.

Temporarily tighten bolt which installs center exhaust pipe to hanger bracket.

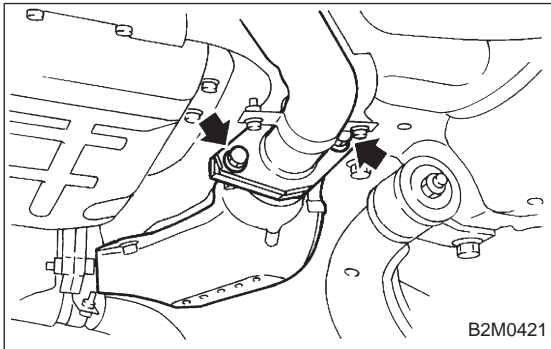

2) Install center exhaust pipe to front catalytic converter.

**Tightening torque:**

$35\pm 5 \text{ N}\cdot\text{m}$  ( $3.6\pm 0.5 \text{ kg}\cdot\text{m}$ ,  $26.0\pm 3.6 \text{ ft}\cdot\text{lb}$ )

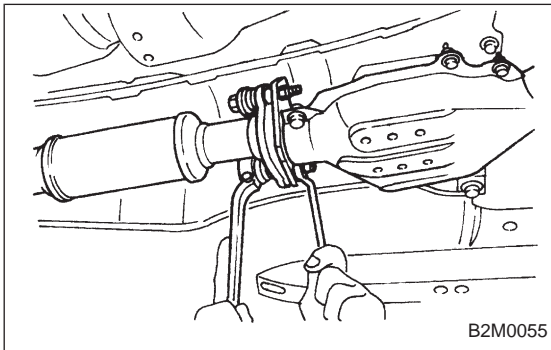

3) Install center exhaust pipe to rear exhaust pipe.

**Tightening torque:**

$18\pm 5 \text{ N}\cdot\text{m}$  ( $1.8\pm 0.5 \text{ kg}\cdot\text{m}$ ,  $13.0\pm 3.6 \text{ ft}\cdot\text{lb}$ )

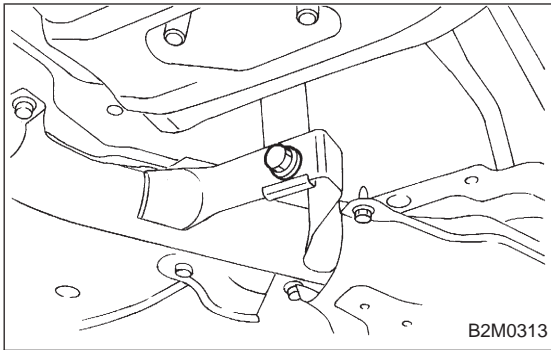

4) Tighten bolt which holds center exhaust pipe to hanger bracket.

**Tightening torque:**

**$35\pm 5$  N·m ( $3.6\pm 0.5$  kg-m,  $26.0\pm 3.6$  ft-lb)**

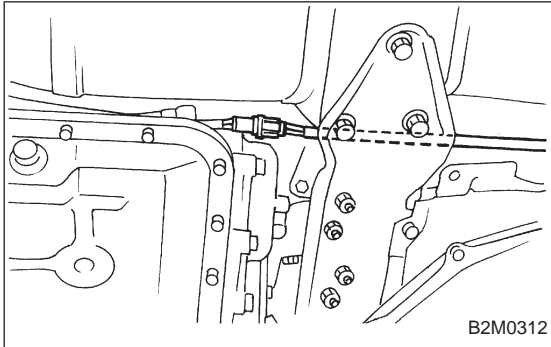

5) Connect rear oxygen sensor connector.

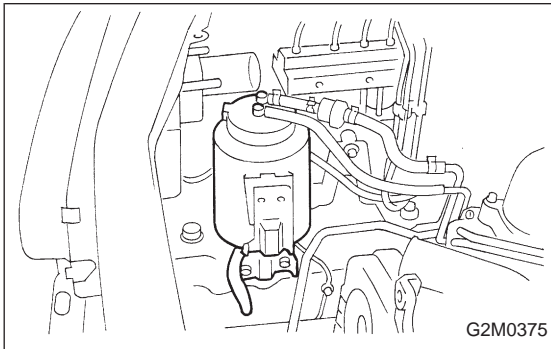

### 3. Canister

#### A: REMOVAL AND INSTALLATION

- 1) Disconnect canister hoses from evaporation pipes.
- 2) Remove canister with bracket.

3) Installation is in the reverse order of removal.

**CAUTION:**

**Insert air vent hose of canister into the hole on body.**

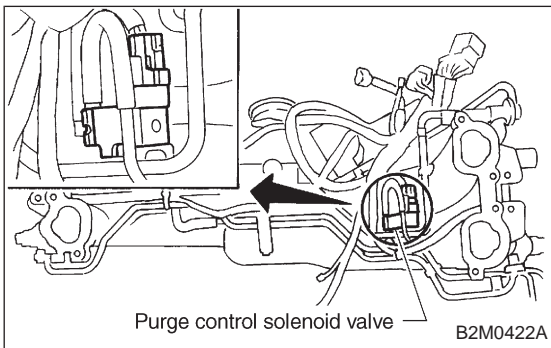

### 4. Purge Control Solenoid Valve

#### A: REMOVAL AND INSTALLATION

- 1) Remove bolt which installs purge control solenoid valve onto intake manifold.

**NOTE:**

This figure shows the rear side of intake manifold.

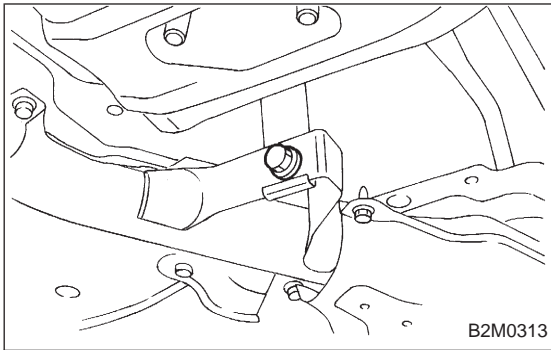

4) Tighten bolt which holds center exhaust pipe to hanger bracket.

**Tightening torque:**

**$35\pm 5$  N·m ( $3.6\pm 0.5$  kg-m,  $26.0\pm 3.6$  ft-lb)**

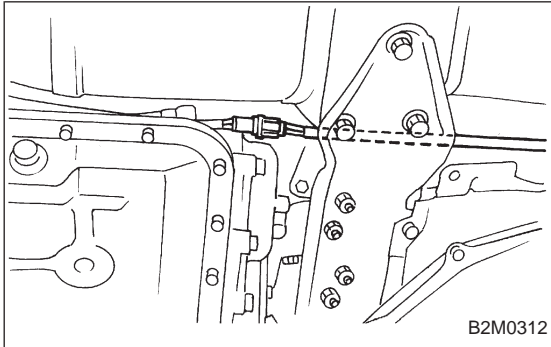

5) Connect rear oxygen sensor connector.

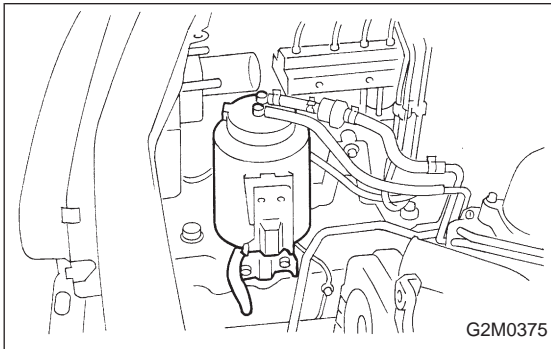

### 3. Canister

#### A: REMOVAL AND INSTALLATION

- 1) Disconnect canister hoses from evaporation pipes.
- 2) Remove canister with bracket.

3) Installation is in the reverse order of removal.

**CAUTION:**

**Insert air vent hose of canister into the hole on body.**

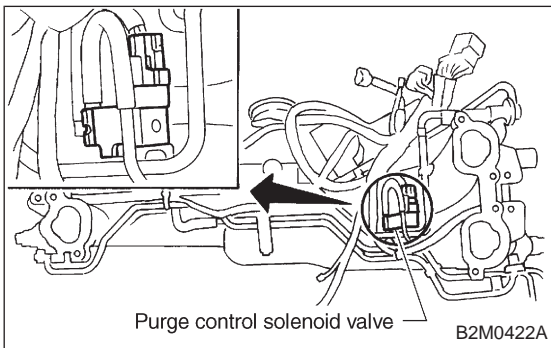

Purge control solenoid valve

B2M0422A

### 4. Purge Control Solenoid Valve

#### A: REMOVAL AND INSTALLATION

- 1) Remove bolt which installs purge control solenoid valve onto intake manifold.

**NOTE:**

This figure shows the rear side of intake manifold.

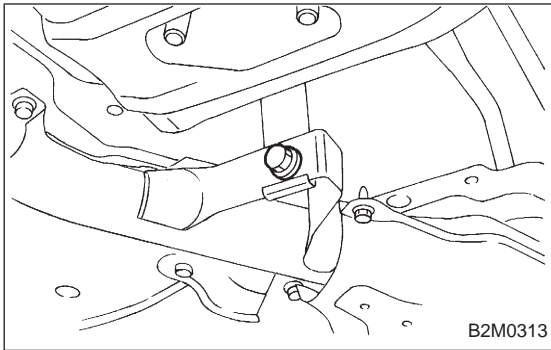

4) Tighten bolt which holds center exhaust pipe to hanger bracket.

**Tightening torque:**

**$35 \pm 5 \text{ N}\cdot\text{m}$  ( $3.6 \pm 0.5 \text{ kg}\cdot\text{m}$ ,  $26.0 \pm 3.6 \text{ ft}\cdot\text{lb}$ )**

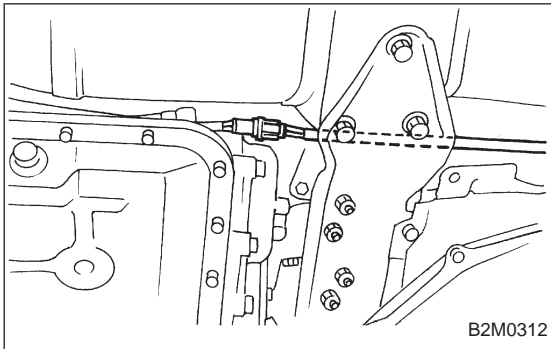

5) Connect rear oxygen sensor connector.

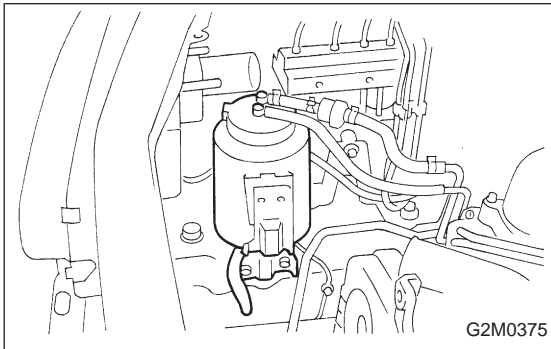

### 3. Canister

#### A: REMOVAL AND INSTALLATION

- 1) Disconnect canister hoses from evaporation pipes.
- 2) Remove canister with bracket.

3) Installation is in the reverse order of removal.

**CAUTION:**

**Insert air vent hose of canister into the hole on body.**

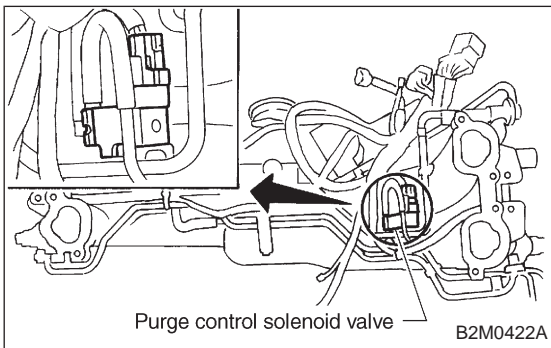

Purge control solenoid valve

B2M0422A

### 4. Purge Control Solenoid Valve

#### A: REMOVAL AND INSTALLATION

- 1) Remove bolt which installs purge control solenoid valve onto intake manifold.

**NOTE:**

This figure shows the rear side of intake manifold.

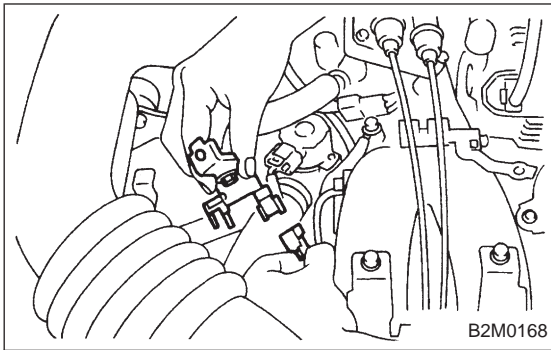

- 2) Take out purge control solenoid valve through the bottom of the intake manifold.
- 3) Disconnect connector and hoses from purge control solenoid valve.

4) Installation is in the reverse order of removal.

**Tightening torque:**

**$16 \pm 1.5 \text{ N}\cdot\text{m}$  ( $1.6 \pm 0.15 \text{ kg}\cdot\text{m}$ ,  $11.6 \pm 1.1 \text{ ft}\cdot\text{lb}$ )**

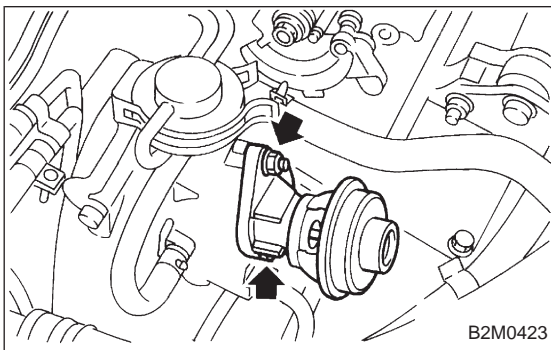

**5. EGR Valve**

**A: REMOVAL AND INSTALLATION**

- 1) Disconnect vacuum hose from EGR valve.
- 2) Remove bolts which install EGR valve onto intake manifold.

3) Installation is in the reverse order of removal.

**CAUTION:**

**Replace gasket with a new one.**

**Tightening torque:**

**$17.1 - 20.1 \text{ N}\cdot\text{m}$  ( $1.74 - 2.05 \text{ kg}\cdot\text{m}$ ,  $12.6 - 14.8 \text{ ft}\cdot\text{lb}$ )**

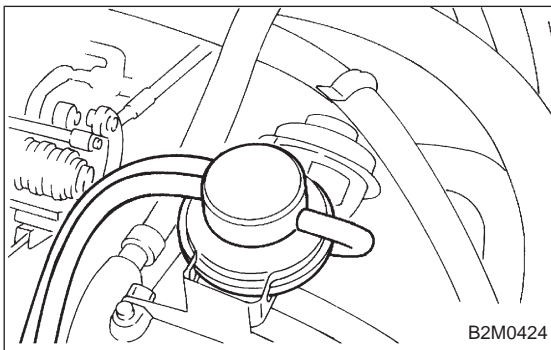

**6. Back-Pressure Transducer (BPT)**

**A: REMOVAL AND INSTALLATION**

- 1) Disconnect vacuum hoses from BPT.
- 2) Remove BPT from bracket.
- 3) Installation is in the reverse order of removal.

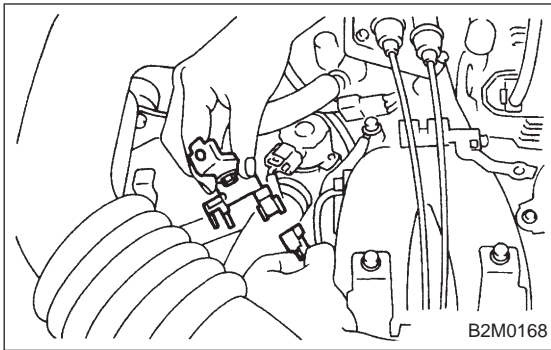

- 2) Take out purge control solenoid valve through the bottom of the intake manifold.
- 3) Disconnect connector and hoses from purge control solenoid valve.

4) Installation is in the reverse order of removal.

**Tightening torque:**

**$16 \pm 1.5 \text{ N}\cdot\text{m}$  ( $1.6 \pm 0.15 \text{ kg}\cdot\text{m}$ ,  $11.6 \pm 1.1 \text{ ft}\cdot\text{lb}$ )**

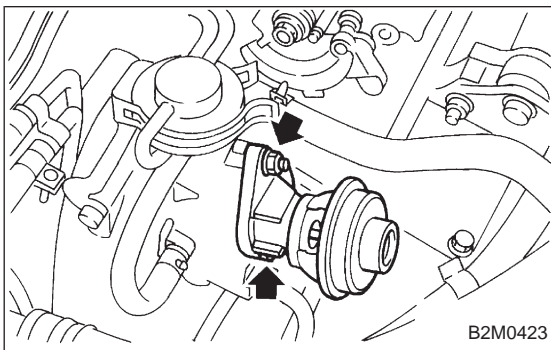

**5. EGR Valve**

**A: REMOVAL AND INSTALLATION**

- 1) Disconnect vacuum hose from EGR valve.
- 2) Remove bolts which install EGR valve onto intake manifold.

3) Installation is in the reverse order of removal.

**CAUTION:**

**Replace gasket with a new one.**

**Tightening torque:**

**$17.1 - 20.1 \text{ N}\cdot\text{m}$  ( $1.74 - 2.05 \text{ kg}\cdot\text{m}$ ,  $12.6 - 14.8 \text{ ft}\cdot\text{lb}$ )**

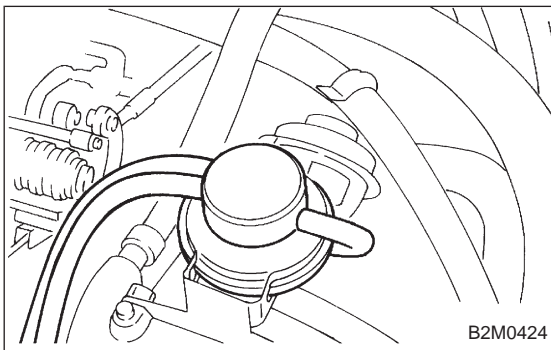

**6. Back-Pressure Transducer (BPT)**

**A: REMOVAL AND INSTALLATION**

- 1) Disconnect vacuum hoses from BPT.
- 2) Remove BPT from bracket.
- 3) Installation is in the reverse order of removal.

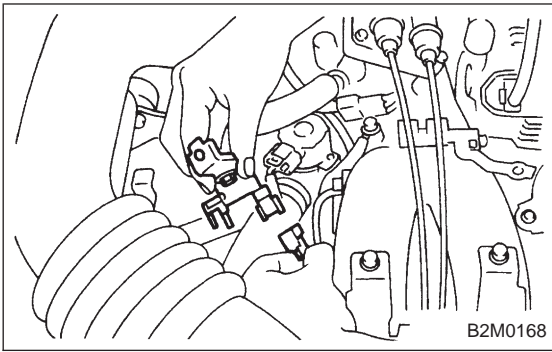

- 2) Take out purge control solenoid valve through the bottom of the intake manifold.
- 3) Disconnect connector and hoses from purge control solenoid valve.

4) Installation is in the reverse order of removal.

**Tightening torque:**

**$16 \pm 1.5 \text{ N}\cdot\text{m}$  ( $1.6 \pm 0.15 \text{ kg}\cdot\text{m}$ ,  $11.6 \pm 1.1 \text{ ft}\cdot\text{lb}$ )**

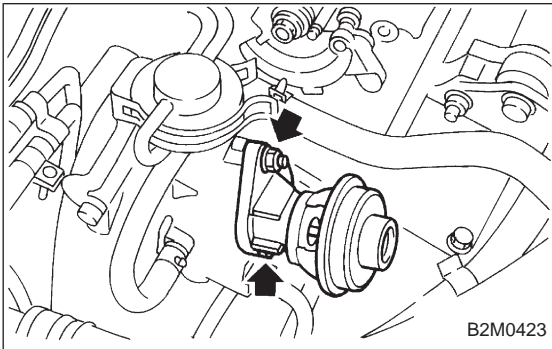

**5. EGR Valve**

**A: REMOVAL AND INSTALLATION**

- 1) Disconnect vacuum hose from EGR valve.
- 2) Remove bolts which install EGR valve onto intake manifold.

3) Installation is in the reverse order of removal.

**CAUTION:**

**Replace gasket with a new one.**

**Tightening torque:**

**$17.1 - 20.1 \text{ N}\cdot\text{m}$  ( $1.74 - 2.05 \text{ kg}\cdot\text{m}$ ,  $12.6 - 14.8 \text{ ft}\cdot\text{lb}$ )**

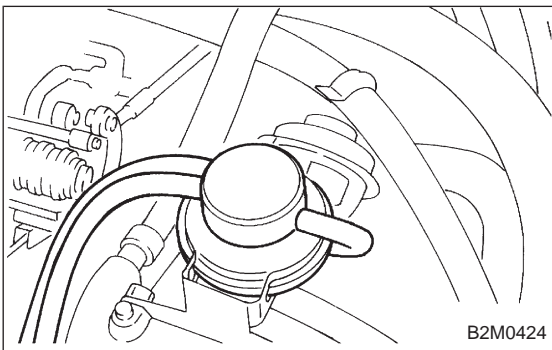

**6. Back-Pressure Transducer (BPT)**

**A: REMOVAL AND INSTALLATION**

- 1) Disconnect vacuum hoses from BPT.
- 2) Remove BPT from bracket.
- 3) Installation is in the reverse order of removal.

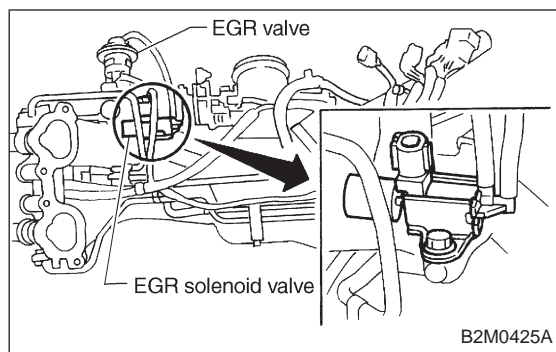

## 7. EGR Solenoid Valve

### A: REMOVAL AND INSTALLATION

- 1) Remove bolt which installs EGR solenoid valve onto intake manifold.
- 2) Disconnect hoses and connector from EGR solenoid valve.

**NOTE:**

This figure shows the rear side of intake manifold.

- 3) Installation is in the reverse order of removal.

**Tightening torque:**

**$19\pm 5$  N·m ( $1.9\pm 0.5$  kg·m,  $13.7\pm 3.6$  ft·lb)**



## 1. Foreword

This chapter describes major inspection and service procedures for the engine mounted on the body. For procedures not found in this chapter, refer to the service procedure section in the applicable chapter.

## 2. Ignition Timing

### A: MEASUREMENT

1) Warm-up the engine.

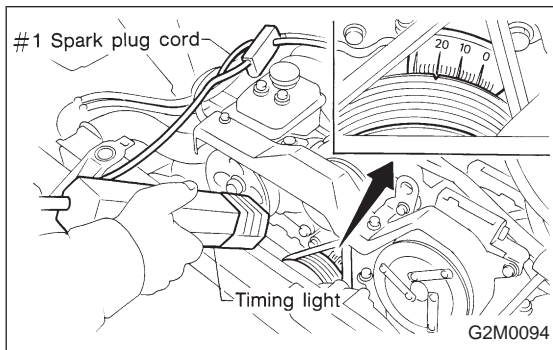

2) To check the ignition timing, connect a timing light to #1 cylinder spark plug cord, and illuminate the timing mark with the timing light.

3) Start the engine at idle speed and check the ignition timing.

If the timing is not correct, check the ignition control system. <Ref. to 2-7 On-Board Diagnostics II System.>

#### **Ignition timing [BTDC/rpm]:**

**$14^{\circ} \pm 8^{\circ} / 700$  (MT)**

**$20^{\circ} \pm 8^{\circ} / 700$  (AT)**

## 1. Foreword

This chapter describes major inspection and service procedures for the engine mounted on the body. For procedures not found in this chapter, refer to the service procedure section in the applicable chapter.

## 2. Ignition Timing

### A: MEASUREMENT

1) Warm-up the engine.

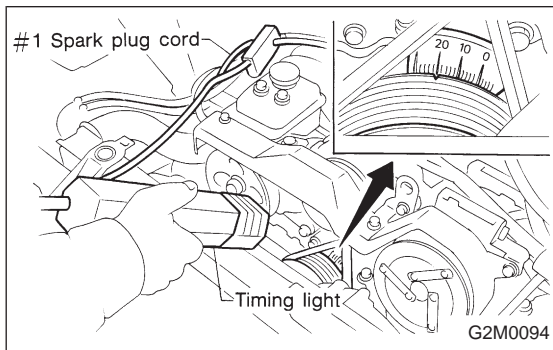

2) To check the ignition timing, connect a timing light to #1 cylinder spark plug cord, and illuminate the timing mark with the timing light.

3) Start the engine at idle speed and check the ignition timing.

If the timing is not correct, check the ignition control system. <Ref. to 2-7 On-Board Diagnostics II System.>

#### **Ignition timing [BTDC/rpm]:**

**$14^{\circ} \pm 8^{\circ} / 700$  (MT)**

**$20^{\circ} \pm 8^{\circ} / 700$  (AT)**

### 3. Engine Idle Speed

#### A: MEASUREMENT

- 1) Before checking idle speed, check the following:
  - (1) Ensure that air cleaner element is free from clogging, ignition timing is correct, spark plugs are in good condition, and that hoses are connected properly.
  - (2) Ensure that malfunction indicator light (CHECK ENGINE light) does not illuminate.
- 2) Warm-up the engine.
- 3) Connect Subaru Select Monitor or the OBD-II general scan tool to data link connector.

**CAUTION:**  
When connecting Subaru Select Monitor, turn ignition switch to OFF.

- 4) Start the engine and measure engine speed.

**NOTE:**

Engine speed is indicated on Subaru Select Monitor by selecting "MODE F04".

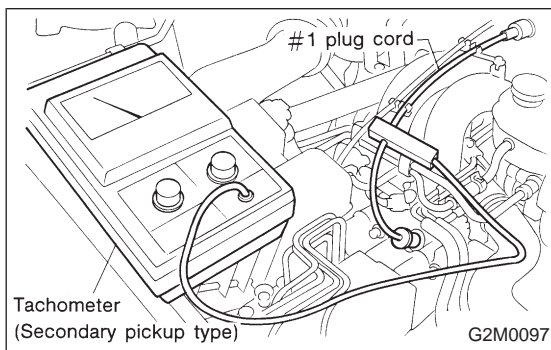
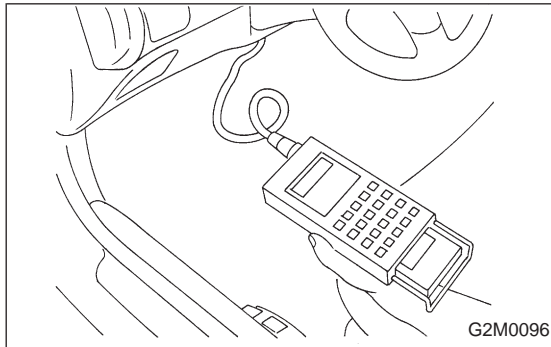

**NOTE:**

- When using the OBD-II general scan tool, carefully read its operation manual.
- When Subaru Select Monitor is not used, attach the pickup sensor on tachometer (Secondary pickup type) to #1 cylinder spark plug cord.
- This ignition system provides simultaneous ignition for #1 and #2 plugs. It must be noted that some tachometers may register twice that of actual engine speed.

5) Check idle speed when unloaded. (With headlights, heater fan, rear defroster, radiator fan, air conditioning, etc. OFF)

***Idle speed (No load and gears in neutral (MT) or N or P (AT) position):***

***700±100 rpm***

6) Check idle speed when loaded. (Turn air conditioning switch to “ON” and operate compressor for at least one minute before measurement.)

***Idle speed [A/C “ON”, no load and gears in neutral (MT) or N or P (AT) position]:***

***850±50 rpm***

**CAUTION:**

**Never rotate idle adjusting screw. If idle speed is out of specifications, refer to General On-board Diagnosis Table under “2-7 On-Board Diagnostics II System”.**

## 4. Engine Compression

### A: MEASUREMENT

- 1) After warming-up the engine, turn ignition switch to OFF.
- 2) Make sure that the battery is fully charged.
- 3) Remove all the spark plugs.
- 4) Disconnect connectors from fuel injectors.
- 5) Fully open throttle valve.
- 6) Check the starter motor for satisfactory performance and operation.
- 7) Hold the compression gauge tight against the spark plug hole.

#### CAUTION:

**When using a screw-in type compression gauge, the screw (put into cylinder head spark plug hole) should be less than 18 mm (0.71 in) long.**

- 8) Crank the engine by means of the starter motor, and read the maximum value on the gauge when the pointer is steady.

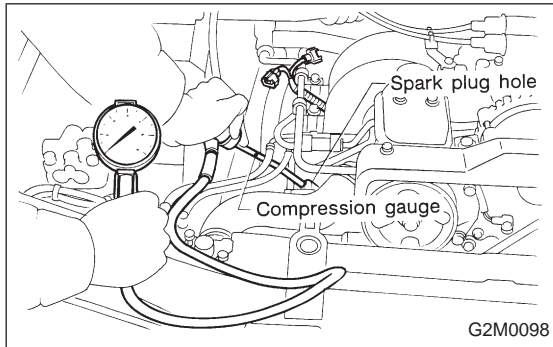

- 9) Perform at least two measurements per cylinder, and make sure that the values are correct.

**Compression (200 — 300 rpm and fully open throttle):**

#### **Standard**

**1,079 — 1,275 kPa**

**(11.0 — 13.0 kg/cm<sup>2</sup>, 156 — 185 psi)**

#### **Limit**

**883 kPa (9.0 kg/cm<sup>2</sup>, 128 psi)**

**Difference between cylinders**

**196 kPa (2.0 kg/cm<sup>2</sup>, 28 psi)**

## 5. Intake Manifold Vacuum

### A: MEASUREMENT

- 1) Warm-up the engine.
- 2) Disconnect the brake vacuum hose and install the vacuum gauge to the hose fitting on the manifold.

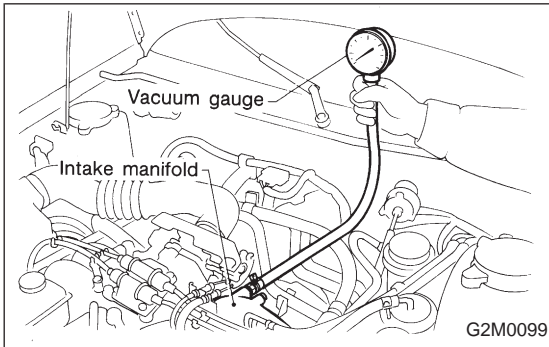

- 3) Keep the engine at the idle speed and read the vacuum gauge indication.

By observing the gauge needle movement, the internal condition of the engine can be diagnosed as described below.

**Vacuum pressure (at idling, A/C "OFF"):**  
**Less than -60.0 kPa**  
**(-450 mmHg, -17.72 inHg)**

Diagnosis of engine condition by measurement of manifold vacuum	
Vacuum gauge indication	Possible engine condition
1. Needle is steady but lower than normal position. This tendency becomes more evident as engine temperature rises.	Leakage around intake manifold gasket or disconnection or damaged vacuum hose
2. When engine speed is reduced slowly from higher speed, needle stops temporarily when it is lowering or becomes steady above normal position.	Back pressure too high, or exhaust system clogged
3. Needle intermittently drops to position lower than normal position.	Leakage around cylinder
4. Needle drops suddenly and intermittently from normal position.	Sticky valves
5. When engine speed is gradually increased, needle begins to vibrate rapidly at certain speed, and then vibration increases as engine speed increases.	Weak or broken valve springs
6. Needle vibrates above and below normal position in narrow range.	Defective ignition system or throttle chamber idle adjustment

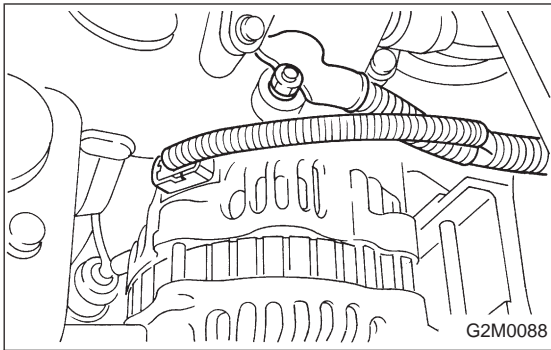

## 6. Engine Oil Pressure

### A: MEASUREMENT

- 1) Remove generator from bracket.
  - (1) Disconnect connector and terminal from generator.

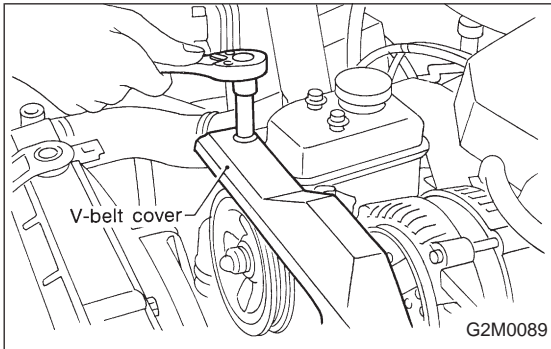

- (2) Remove V-belt cover.
- (3) Loosen lock bolt and slider bolt, and remove V-belt for generator.

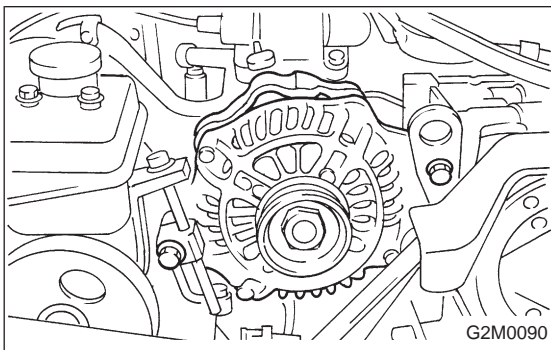

- (4) Remove generator lock bolt.
- (5) Remove bolt which install generator on bracket.

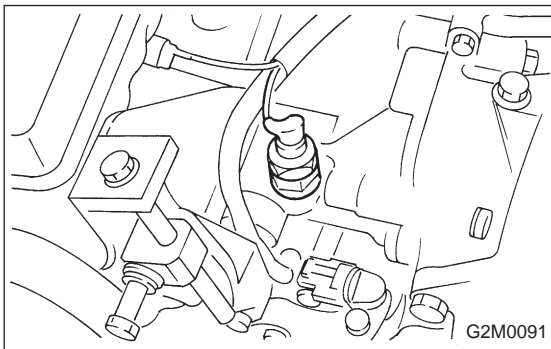

- 2) Disconnect connector from oil pressure switch.
- 3) Remove oil pressure switch from engine cylinder block.

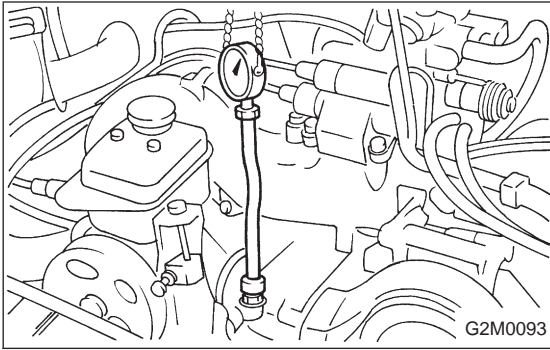

- 4) Connect oil pressure gauge hose to cylinder block.
- 5) Start the engine, and measure oil pressure.

**Oil pressure:**

**98 kPa (1.0 kg/cm<sup>2</sup>, 14 psi) or more at 800 rpm**

**294 kPa (3.0 kg/cm<sup>2</sup>, 43 psi) or more at 5,000 rpm**

**CAUTION:**

- If oil pressure is out of specification, check oil pump, oil filter and lubrication line.

<Ref. to 2-4 [K100].>

- If oil pressure warning light is turned ON and oil pressure is in specification, replace oil pressure switch.

<Ref. to 2-4 [W3A0].>

**NOTE:**

The specified data is based on an engine oil temperature of 80°C (176°F).

- 6) After measuring oil pressure, install oil pressure switch.

**Tightening torque:**

**25±3 N·m (2.5±0.3 kg·m, 18.1±2.2 ft·lb)**

- 7) Install generator and V-belt in the reverse order of removal, and adjust the V-belt deflection.



**1. Engine**  
**A: SPECIFICATIONS**

Engine	Model		2200 cc
	Type		Horizontally opposed, liquid cooled, 4-cylinder, 4-stroke gasoline engine
	Valve arrangement		Belt driven, single over-head camshaft, 4-valve/cylinder
	Bore x Stroke		mm (in) 96.9 x 75.0 (3.815 x 2.953)
	Displacement		cm <sup>3</sup> (cu in) 2,212 (135.0)
	Compression ratio		9.5
	Compression pressure (at 200 — 300 rpm)		kPa (kg/cm <sup>2</sup> , psi) 1,079 — 1,275 (11.0 — 13.0, 156 — 185)
	Number of piston rings		Pressure ring: 2, Oil ring: 1
	Intake valve timing	Opening	1° BTDC
		Closing	55° ABDC
	Exhaust valve timing	Opening	48° BBDC
		Closing	12° ATDC
	Idling speed [At neutral position on MT, or "P" or "N" position on AT]		rpm 700±100 (No load) 850±50 (A/C switch ON)
	Firing order		1 → 3 → 2 → 4
Ignition timing		BTDC/rpm 14°±8°/700 (MT), 20°±8°/700 (AT)	

**B: SERVICE DATA**

Belt tension adjuster	Protrusion of adjuster rod			15.4 — 16.4 mm	(0.606 — 0.646 in)	
Belt tensioner	Spacer O.D.			16 mm	(0.63 in)	
	Tensioner bush I.D.			16.16 mm	(0.6362 in)	
	Clearance between spacer and bush		STD	0.117 — 0.180 mm	(0.0046 — 0.0071 in)	
			Limit	0.230 mm	(0.0091 in)	
	Side clearance of spacer		STD	0.37 — 0.54 mm	(0.0146 — 0.0213 in)	
Limit			0.8 mm	(0.031 in)		
Valve rocker arm	Clearance between shaft and arm			STD	0.020 — 0.054 mm (0.0008 — 0.0021 in)	
				Limit	0.10 mm (0.0039 in)	
Camshaft	Bend limit			0.025 mm	(0.0010 in)	
	Thrust clearance		STD	0.030 — 0.260 mm	(0.0012 — 0.0102 in)	
			Limit	0.35 mm	(0.0138 in)	
	Cam lobe height		Intake	STD	31.994 — 32.094 mm	(1.2596 — 1.2635 in)
				Limit	31.844 mm	(1.2537 in)
			Exhaust	STD	32.624 — 32.724 mm	(1.2844 — 1.2883 in)
				Limit	32.474 mm	(1.2785 in)
	Camshaft journal O.D.	RH	Front	LH	Rear	31.935 — 31.950 mm (1.2573 — 1.2579 in)
			Center		Center	37.435 — 37.450 mm (1.4738 — 1.4744 in)
			Rear		Front	37.935 — 37.950 mm (1.4935 — 1.4941 in)
	Camshaft journal hole I.D.	RH	Front	LH	Rear	32.005 — 32.025 mm (1.2600 — 1.2608 in)
			Center		Center	37.505 — 37.525 mm (1.4766 — 1.4774 in)
			Rear		Front	38.005 — 38.025 mm (1.4963 — 1.4970 in)
Oil clearance			STD	0.055 — 0.090 mm	(0.0022 — 0.0035 in)	
			Limit	0.10 mm	(0.0039 in)	
Cylinder head	Surface warpage limit			0.05 mm	(0.0020 in)	
	Surface grinding limit			0.1 mm	(0.004 in)	
	Standard height			98.3 mm	(3.870 in)	
Valve set	Refacing angle			90°		
	Contacting width		Intake	STD	0.7 mm	(0.028 in)
				Limit	1.4 mm	(0.055 in)
			Exhaust	STD	1.4 mm	(0.055 in)
				Limit	1.8 mm	(0.071 in)
Valve guide	Inner diameter			6.000 — 6.012 mm	(0.2362 — 0.2367 in)	
	Protrusion above head			17.5 — 18.0 mm	(0.689 — 0.709 in)	
Valve	Head edge thickness		Intake	STD	1.0 mm	(0.039 in)
				Limit	0.8 mm	(0.031 in)
			Exhaust	STD	1.2 mm	(0.047 in)
				Limit	0.8 mm	(0.031 in)
	Stem diameter		Intake	5.950 — 5.965 mm	(0.2343 — 0.2348 in)	
			Exhaust	5.945 — 5.960 mm	(0.2341 — 0.2346 in)	
	Stem oil clearance		STD	Intake	0.035 — 0.062 mm	(0.0014 — 0.0024 in)
				Exhaust	0.040 — 0.067 mm	(0.0016 — 0.0026 in)
Limit			—	0.15 mm	(0.0059 in)	
Overall length		Intake	101.0 mm	(3.976 in)		
		Exhaust	101.2 mm	(3.984 in)		

STD: Standard I.D.: Inner Diameter O.D.: Outer Diameter

## 1. Engine

Valve spring	Free length		44.05 mm	(1.7342 in)	
	Squareness		2.5°, 1.9 mm	(0.075 in)	
	Tension/spring height		174.6 — 200.1 N (17.8 — 20.4 kg, 39.2 — 45.0 lb)/36.0 mm (1.417 in) 405.0 — 458.0 N (41.3 — 46.7 kg, 91.1 — 103.0 lb)/28.2 mm (1.110 in)		
Cylinder block	Surface warpage limit (mating with cylinder head)			0.05 mm	(0.0020 in)
	Surface grinding limit			0.1 mm	(0.004 in)
	Cylinder bore	STD	A	96.905 — 96.915 mm	(3.8151 — 3.8155 in)
			B	96.895 — 96.905 mm	(3.8148 — 3.8151 in)
	Taper	STD		0.015 mm	(0.0006 in)
		Limit		0.050 mm	(0.0020 in)
	Out-of-roundness	STD		0.010 mm	(0.0004 in)
		Limit		0.050 mm	(0.0020 in)
	Piston clearance	STD		0.010 — 0.030 mm	(0.0004 — 0.0012 in)
Limit		0.050 mm	(0.0020 in)		
Enlarging (boring) limit			0.5 mm	(0.020 in)	
Piston	Outer diameter	STD	A	96.885 — 96.895 mm	(3.8144 — 3.8148 in)
			B	96.875 — 96.885 mm	(3.8140 — 3.8144 in)
		0.25 mm (0.0098 in) OS		97.115 — 97.145 mm	(3.8234 — 3.8246 in)
		0.50 mm (0.0197 in) OS		97.365 — 97.395 mm	(3.8333 — 3.8344 in)
Piston pin	Standard clearance between piston pin and hole in piston		STD	0.004 — 0.010 mm	(0.0002 — 0.0004 in)
			Limit	0.020 mm	(0.0008 in)
	Degree of fit		Piston pin must be fitted into position with thumb at 20°C (68°F).		
Piston ring	Piston ring gap	Top ring	STD	0.20 — 0.35 mm	(0.0079 — 0.0138 in)
			Limit	1.0 mm	(0.039 in)
		Second ring	STD	0.20 — 0.50 mm	(0.0079 — 0.0197 in)
			Limit	1.0 mm	(0.039 in)
	Oil ring	STD	0.20 — 0.70 mm	(0.0079 — 0.0276 in)	
		Limit	1.5 mm	(0.059 in)	
	Clearance between piston ring and piston ring groove	Top ring	STD	0.040 — 0.080mm	(0.0016 — 0.0031 in)
			Limit	0.15 mm	(0.0059 in)
Second ring		STD	0.030 — 0.070 mm	(0.0012 — 0.0028 in)	
		Limit	0.15 mm	(0.0059 in)	
Connecting rod	Bend twist per 100 mm (3.94 in) in length		Limit	0.10 mm	(0.0039 in)
	Side clearance		STD	0.070 — 0.330 mm	(0.0028 — 0.0130 in)
Limit			0.4 mm	(0.016 in)	
Connecting rod bearing	Oil clearance		STD	0.015 — 0.045 mm	(0.0006 — 0.0018 in)
			Limit	0.05 mm	(0.0020 in)
	Thickness at center portion		STD	1.492 — 1.501 mm	(0.0587 — 0.0591 in)
			0.03 mm (0.0012 in) US	1.510 — 1.513 mm	(0.0594 — 0.0596 in)
			0.05 mm (0.0020 in) US	1.520 — 1.523 mm	(0.0598 — 0.0600 in)
		0.25 mm (0.0098 in) US	1.620 — 1.623 mm	(0.0638 — 0.0639 in)	
Connecting rod bushing	Clearance between piston pin and bushing		STD	0 — 0.022 mm	(0 — 0.0009 in)
			Limit	0.030 mm	(0.0012 in)

STD: Standard OS: Oversize US: Undersize

# SPECIFICATIONS AND SERVICE DATA

**2-3**

1. Engine

Crankshaft	Bend limit		0.035 mm	(0.0014 in)	
	Crank pin and crank journal	Out-of-roundness	0.030 mm (0.0012 in) or less		
		Grinding limit	0.25 mm	(0.0098 in)	
	Crank pin outer diameter		STD	51.984 — 52.000 mm	(2.0466 — 2.0472 in)
			0.03 mm (0.0012 in) US	51.954 — 51.970 mm	(2.0454 — 2.0461 in)
			0.05 mm (0.0020 in) US	51.934 — 51.950 mm	(2.0446 — 2.0453 in)
			0.25 mm (0.0098 in) US	51.734 — 51.750 mm	(2.0368 — 2.0374 in)
	Crank journal outer diameter	#1, #5	STD	59.992 — 60.008 mm	(2.3619 — 2.3625 in)
			0.03 mm (0.0012 in) US	59.962 — 59.978 mm	(2.3607 — 2.3613 in)
			0.05 mm (0.0020 in) US	59.934 — 59.950 mm	(2.3596 — 2.3602 in)
			0.25 mm (0.0098 in) US	59.742 — 59.758 mm	(2.3520 — 2.3527 in)
		#2, #3, #4	STD	59.992 — 60.008 mm	(2.3619 — 2.3625 in)
			0.03 mm (0.0012 in) US	59.954 — 59.970 mm	(2.3604 — 2.3610 in)
			0.05 mm (0.0020 in) US	59.934 — 59.950 mm	(2.3596 — 2.3602 in)
			0.25 mm (0.0098 in) US	59.734 — 59.750 mm	(2.3517 — 2.3524 in)
Thrust clearance		STD	0.030 — 0.115 mm	(0.0012 — 0.0045 in)	
		Limit	0.25 mm	(0.0098 in)	
Oil clearance	#1, #5	STD	0.003 — 0.030 mm	(0.0001 — 0.0012 in)	
	#2, #3, #4	STD	0.010 — 0.033 mm	(0.0004 — 0.0013 in)	
	#1, #3, #5	Limit	0.040 mm	(0.0016 in)	
	#2, #4	Limit	0.035 mm	(0.0014 in)	
Crankshaft bearing	Crankshaft bearing thickness	#1, #5	STD	1.998 — 2.011 mm	(0.0787 — 0.0792 in)
			0.03 mm (0.0012 in) US	2.017 — 2.020 mm	(0.0794 — 0.0795 in)
			0.05 mm (0.0020 in) US	2.027 — 2.030 mm	(0.0798 — 0.0799 in)
			0.25 mm (0.0098 in) US	2.127 — 2.130 mm	(0.0837 — 0.0839 in)
		#2, #3, #4	STD	2.000 — 2.013 mm	(0.0787 — 0.0793 in)
			0.03 mm (0.0012 in) US	2.019 — 2.022 mm	(0.0795 — 0.0796 in)
			0.05 mm (0.0020 in) US	2.029 — 2.032 mm	(0.0799 — 0.0800 in)
			0.25 mm (0.0098 in) US	2.129 — 2.132 mm	(0.0838 — 0.0839 in)

STD: Standard US: Undersize

1. Timing Belt

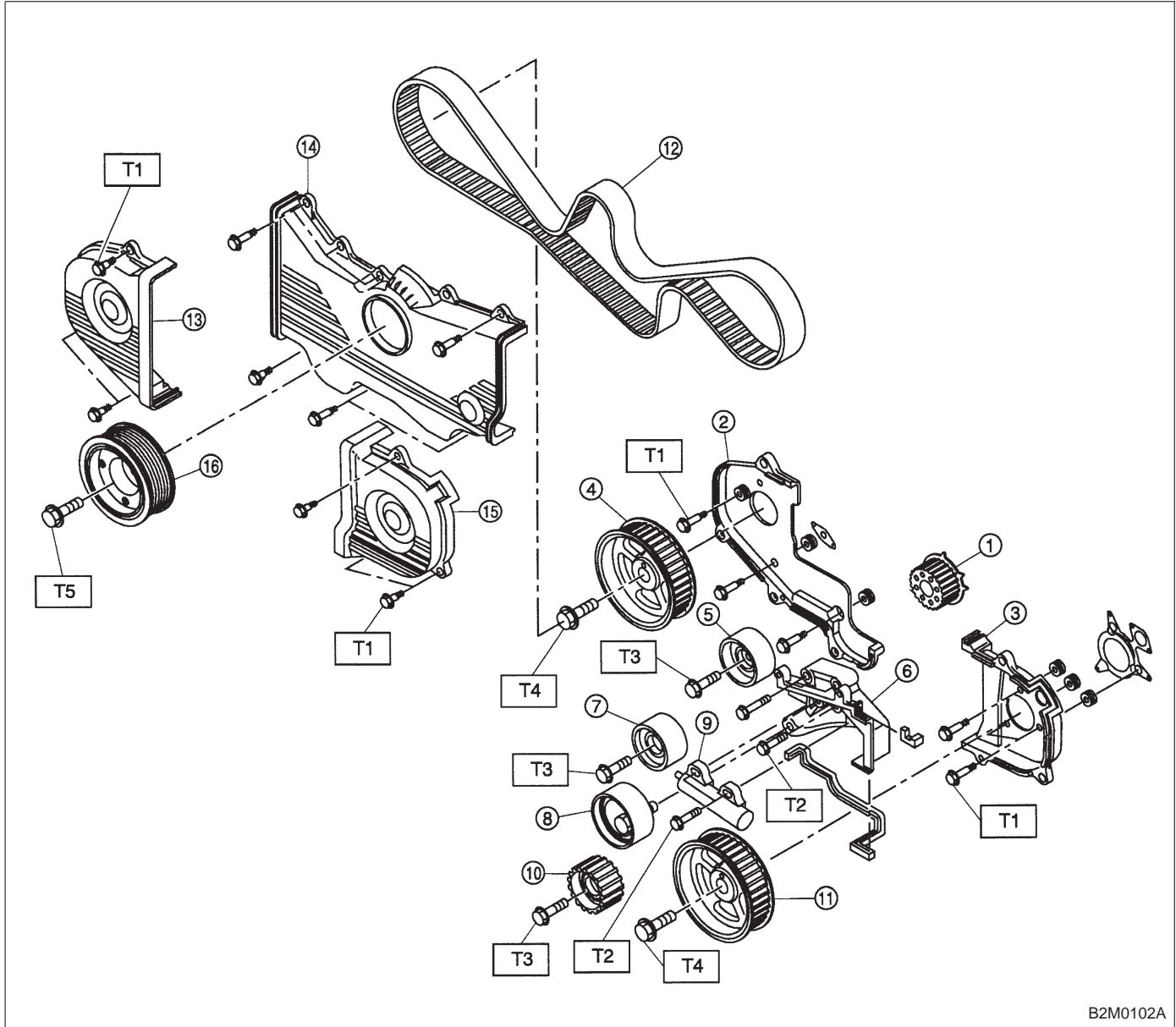

B2M0102A

- ① Crankshaft sprocket
- ② Belt cover No. 2 (RH)
- ③ Belt cover No. 2 (LH)
- ④ Camshaft sprocket (RH)
- ⑤ Belt idler
- ⑥ Tensioner bracket
- ⑦ Belt idler
- ⑧ Belt tensioner
- ⑨ Tensioner adjuster
- ⑩ Belt idler No. 2
- ⑪ Camshaft sprocket (LH)
- ⑫ Timing belt

- ⑬ Belt cover (RH)
- ⑭ Front belt cover
- ⑮ Belt cover (LH)
- ⑯ Crankshaft pulley

**Tightening torque: N·m (kg·m, ft·lb)**

**T1: 5±1 (0.5±0.1, 3.6±0.7)**  
**T2: 25±2 (2.5±0.2, 18.1±1.4)**  
**T3: 39±4 (4.0±0.4, 28.9±2.9)**  
**T4: 78±5 (8.0±0.5, 57.9±3.6)**  
**T5: 108<sup>+10</sup><sub>-5</sub> (11<sup>+1.0</sup><sub>-0.5</sub>, 79.6<sup>+7.2</sup><sub>-3.6</sub>)**

2. Cylinder Head and Camshaft

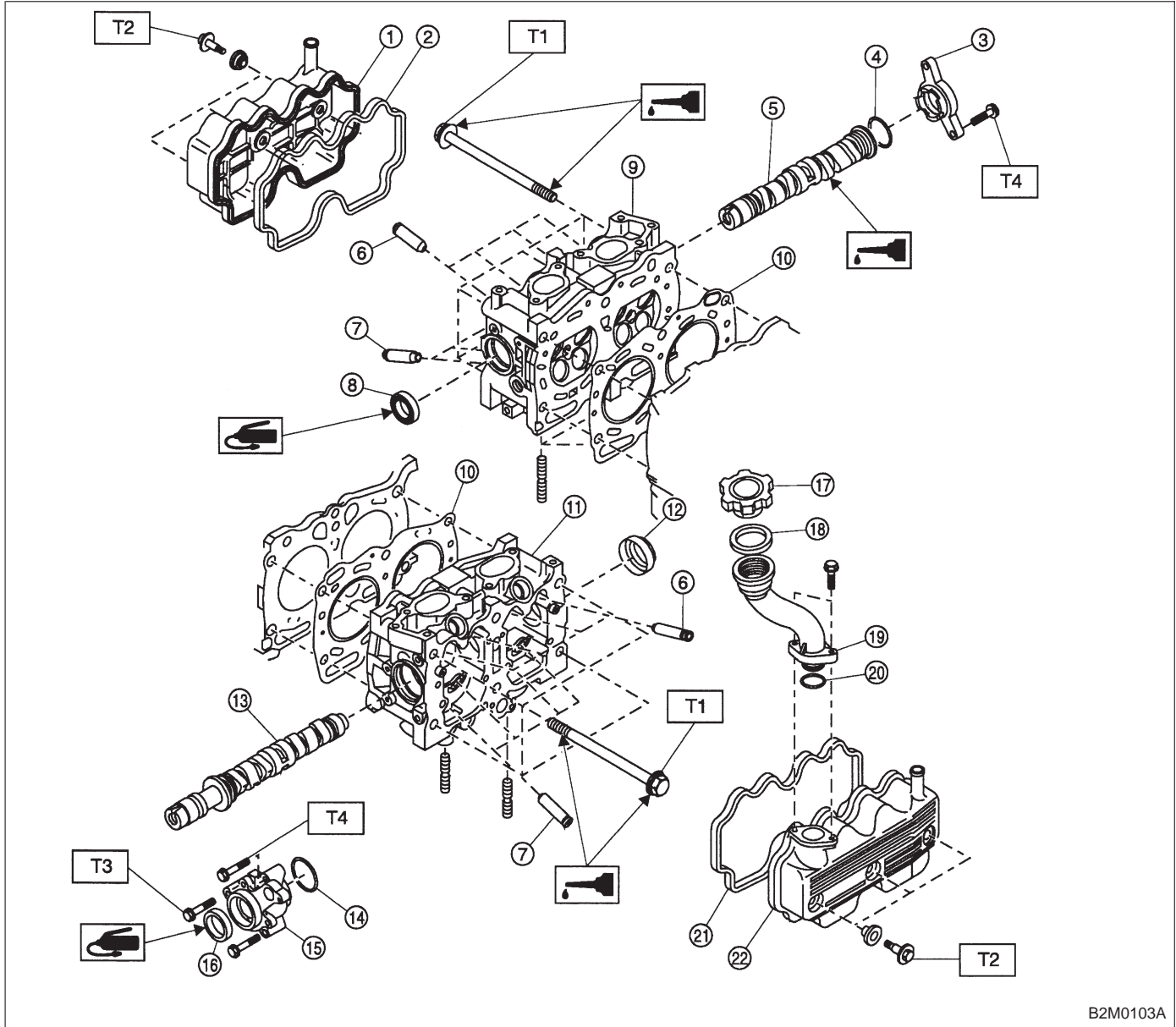

B2M0103A

- ① Rocker cover (RH)
- ② Rocker cover gasket
- ③ Camshaft support (RH)
- ④ O-ring
- ⑤ Camshaft (RH)
- ⑥ Intake valve guide
- ⑦ Exhaust valve guide
- ⑧ Oil seal
- ⑨ Cylinder head (RH)
- ⑩ Cylinder head gasket
- ⑪ Cylinder head (LH)
- ⑫ Plug
- ⑬ Camshaft (LH)
- ⑭ O-ring
- ⑮ Camshaft support (LH)

- ⑯ Oil seal
- ⑰ Oil filler cap
- ⑱ Gasket
- ⑲ Oil filler pipe
- ⑳ O-ring
- ㉑ Rocker cover gasket
- ㉒ Rocker cover (LH)

**Tightening torque: N·m (kg·m, ft·lb)**

**T1: Refer to [W6E1].**

**T2: 5±1 (0.5±0.1, 3.6±0.7)**

**T3: 10 (1.0, 7)**

**T4: 16 (1.6, 12)**

## 3. Cylinder Head and Valve Assembly

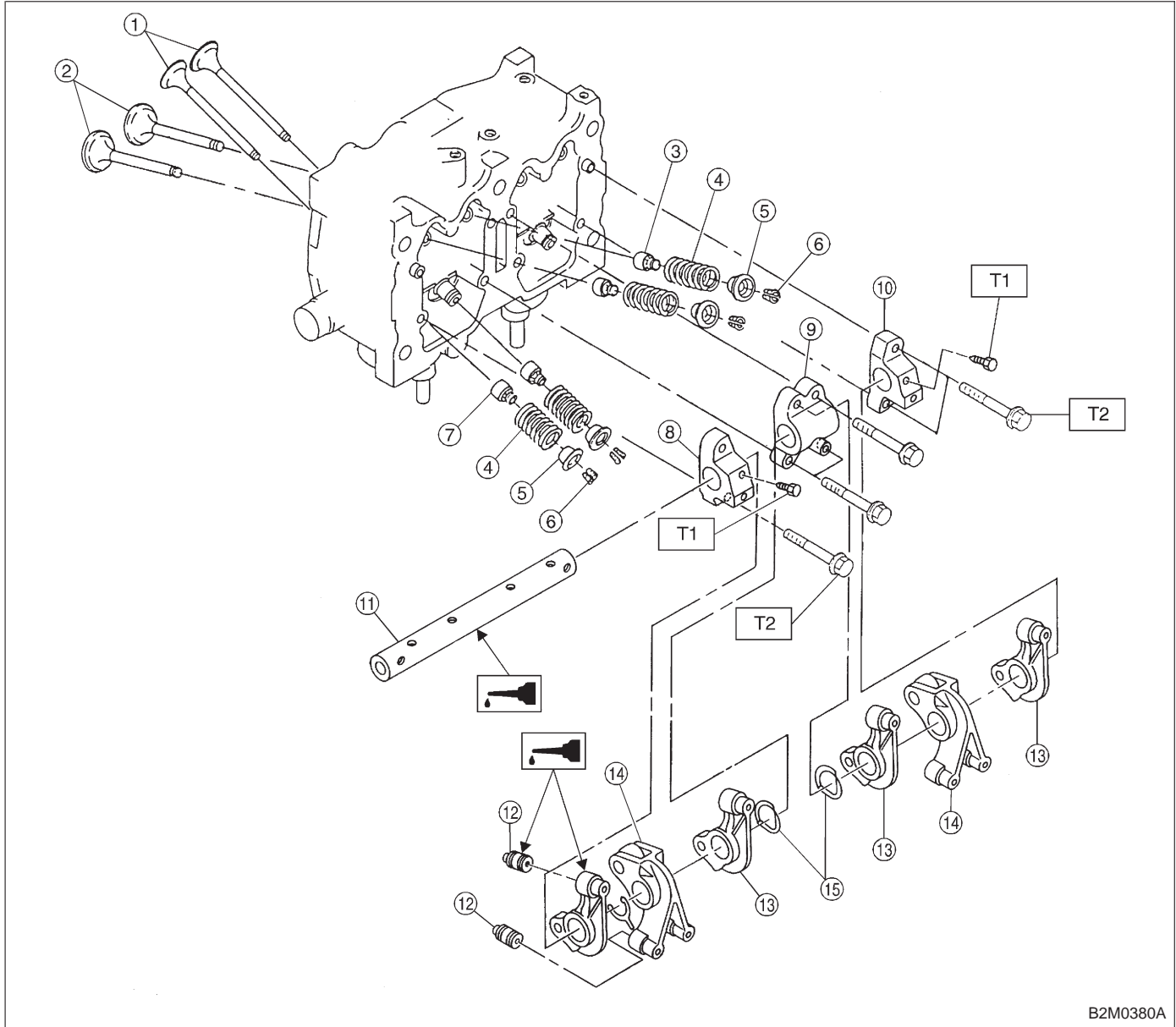

- ① Exhaust valve
- ② Intake valve
- ③ Intake valve oil seal
- ④ Valve spring
- ⑤ Retainer
- ⑥ Retainer key
- ⑦ Exhaust valve oil seal
- ⑧ Rocker shaft support
- ⑨ Rocker shaft support
- ⑩ Rocker shaft support

- ⑪ Rocker shaft
- ⑫ Hydraulic lash adjuster
- ⑬ Intake valve rocker arm
- ⑭ Exhaust valve rocker arm
- ⑮ Spring

**Tightening torque: N·m (kg·m, ft·lb)**

**T1: 5±1 (0.5±0.1, 3.6±0.7)**

**T2: 12±1 (1.2±0.1, 8.7±0.7)**

4. Cylinder Block

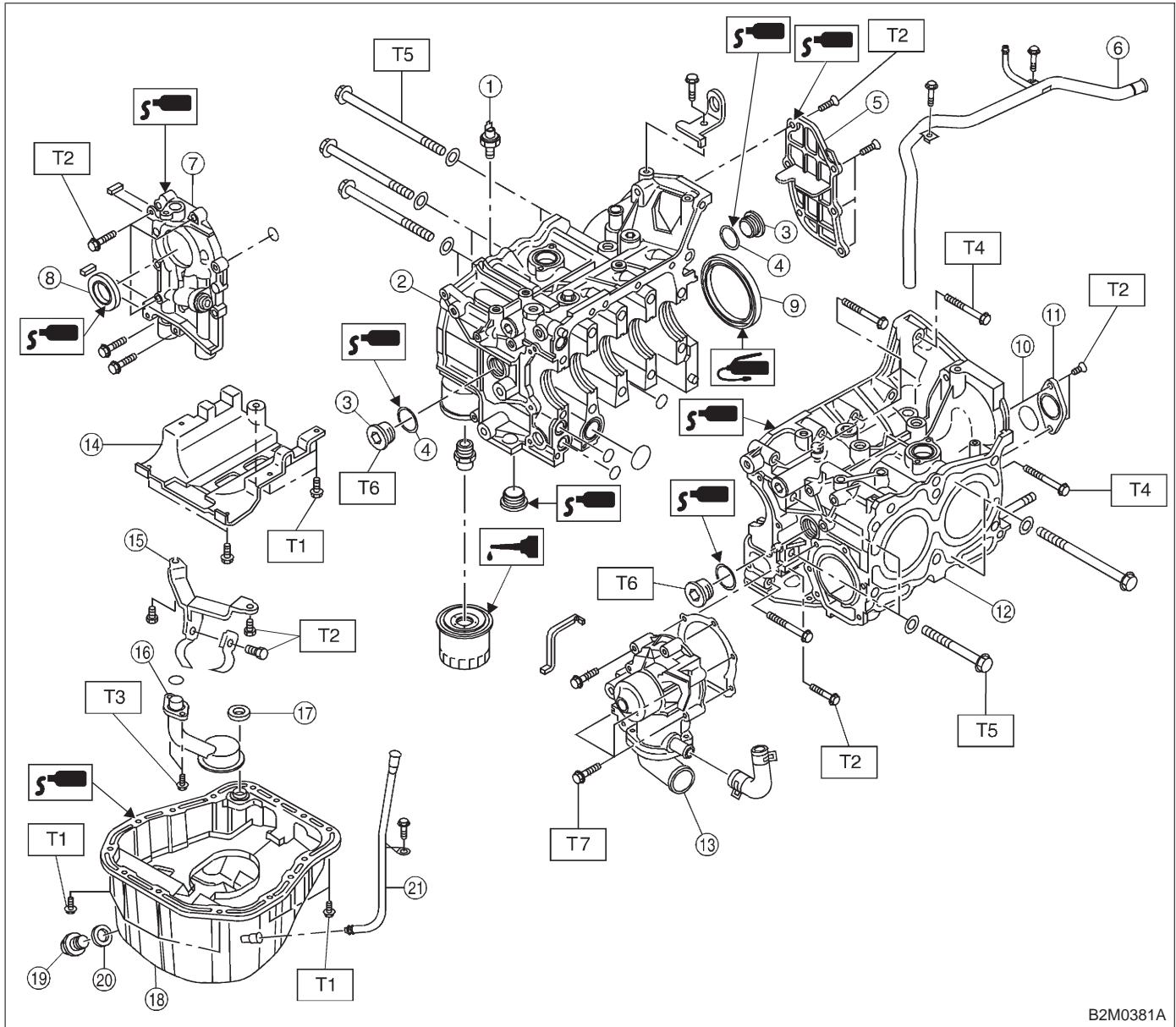

B2M0381A

- ① Oil pressure switch
- ② Cylinder block (RH)
- ③ Service hole plug
- ④ Gasket
- ⑤ Oil separator cover
- ⑥ Water pipe
- ⑦ Oil pump
- ⑧ Front oil seal
- ⑨ Rear oil seal
- ⑩ O-ring
- ⑪ Service hole cover
- ⑫ Cylinder block (LH)
- ⑬ Water pump
- ⑭ Baffle plate
- ⑮ Oil strainer stay
- ⑯ Oil strainer

- ⑰ Gasket
- ⑱ Oil pan
- ⑲ Oil drain plug
- ⑳ Gasket
- ㉑ Oil filler pipe

**Tightening torque: N-m (kg-m, ft-lb)**

- T1: 5 (0.5, 3.6)
- T2: 6.4 (0.65, 4.7)
- T3: 10 (1.0, 7)
- T4: 25±2 (2.5±0.2, 18.1±1.4)
- T5: 47±3 (4.8±0.3, 34.7±2.2)
- T6: 69±7 (7.0±0.7, 50.6±5.1)
- T7: First 12±2 (1.2±0.2, 8.7±1.4)
- Second 12±2 (1.2±0.2, 8.7±1.4)



5. Crankshaft and Piston

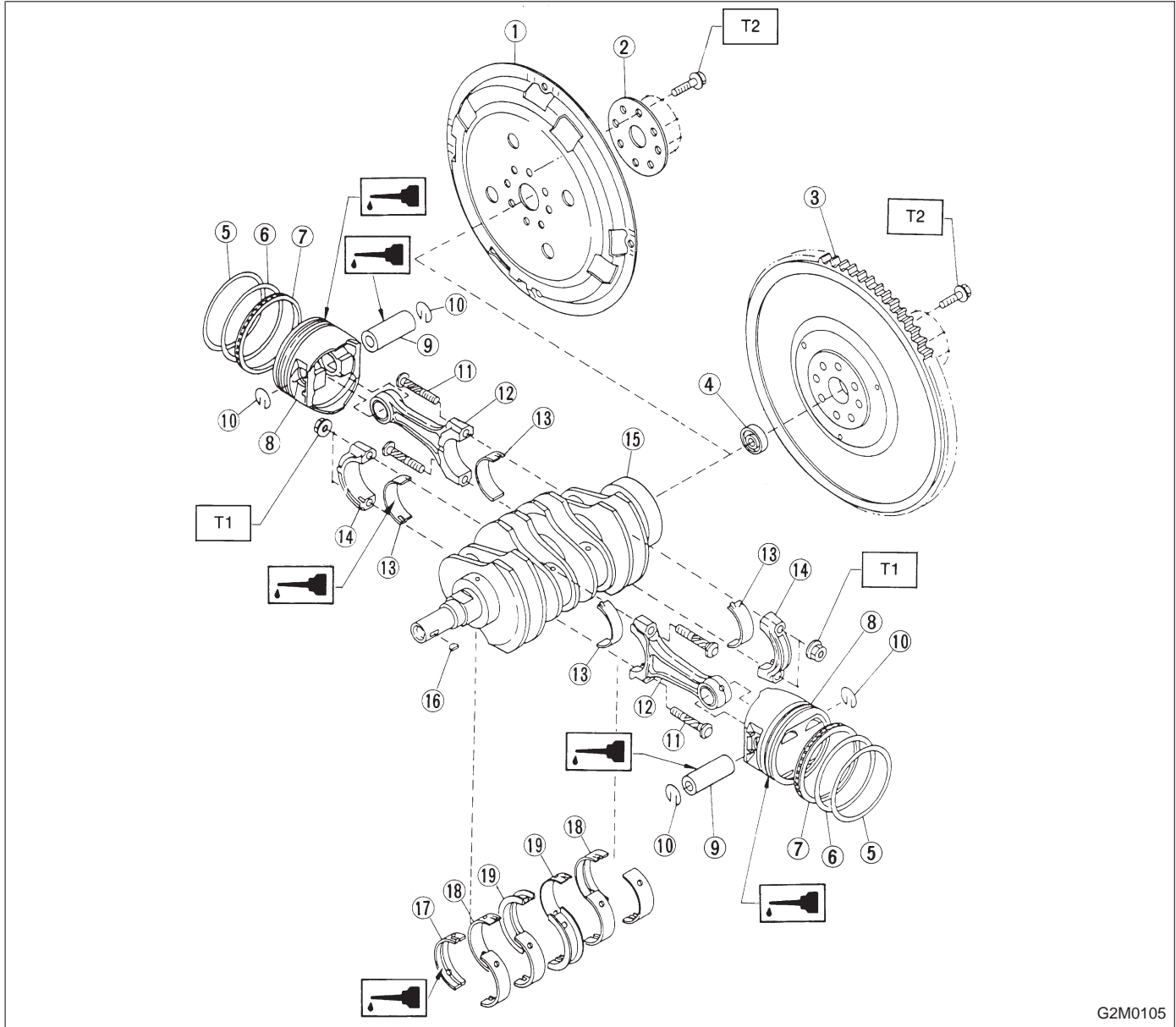

G2M0105

- ① Drive plate (AT)
- ② Reinforcement (AT)
- ③ Flywheel (MT)
- ④ Bell bearing (MT)
- ⑤ Top ring
- ⑥ Second ring
- ⑦ Oil ring
- ⑧ Piston
- ⑨ Piston pin
- ⑩ Circlip
- ⑪ Connecting rod bolt
- ⑫ Connecting rod

- ⑬ Connecting rod bearing
- ⑭ Connecting rod cap
- ⑮ Crankshaft
- ⑯ Woodruff key
- ⑰ Crankshaft bearing #1, #5
- ⑱ Crankshaft bearing #2, #4
- ⑲ Crankshaft bearing #3

**Tightening torque: N·m (kg·m, ft·lb)**

**T1: 44±2 (4.5±0.2, 32.5±1.4)**

**T2: 72±3 (7.3±0.3, 52.8±2.2)**

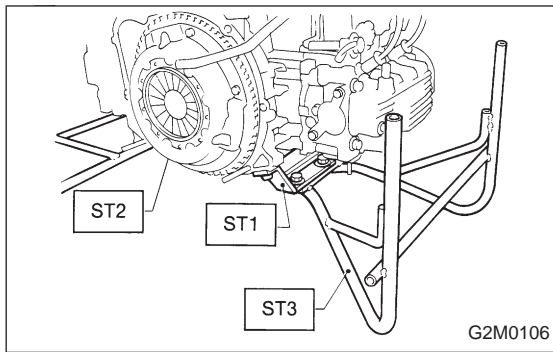

**1. General Precautions**

1) Before disassembling engine, place it on ST3.

ST1	498457000	ENGINE STAND ADAPTER RH
ST2	498457100	ENGINE STAND ADAPTER LH
ST3	499817000	ENGINE STAND

- 2) All parts should be thoroughly cleaned, paying special attention to the engine oil passages, pistons and bearings.
- 3) Rotating parts and sliding parts such as piston, bearing and gear should be coated with oil prior to assembly.
- 4) Be careful not to let oil, grease or coolant contact the timing belt, clutch disc and flywheel.
- 5) All removed parts, if to be reused, should be reinstalled in the original positions and directions.
- 6) Gaskets and lock washers must be replaced with new ones. Liquid gasket should be used where specified to prevent leakage.
- 7) Bolts, nuts and washers should be replaced with new ones as required.
- 8) Even if necessary inspections have been made in advance, proceed with assembly work while making rechecks.

**2. Hydraulic Lash Adjuster**

**A: INSPECTION**

- 1) Disconnect blow-by hose from rocker cover.
- 2) Remove spark plug cap.

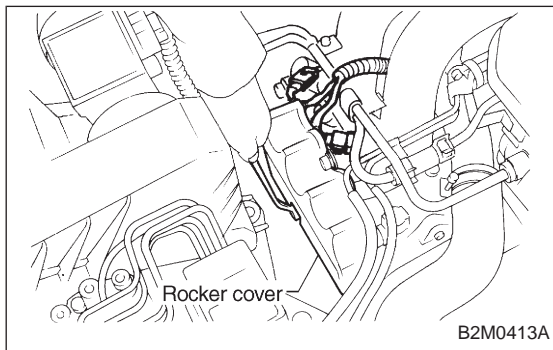

3) Remove left and right rocker covers.

**CAUTION:**

**Before removing left rocker cover, disconnect battery cables and generator cable.**

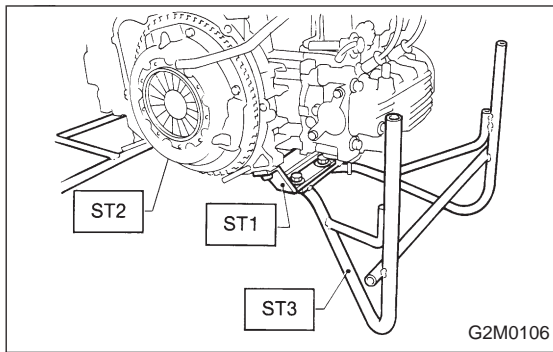

**1. General Precautions**

1) Before disassembling engine, place it on ST3.

ST1	498457000	ENGINE STAND ADAPTER RH
ST2	498457100	ENGINE STAND ADAPTER LH
ST3	499817000	ENGINE STAND

- 2) All parts should be thoroughly cleaned, paying special attention to the engine oil passages, pistons and bearings.
- 3) Rotating parts and sliding parts such as piston, bearing and gear should be coated with oil prior to assembly.
- 4) Be careful not to let oil, grease or coolant contact the timing belt, clutch disc and flywheel.
- 5) All removed parts, if to be reused, should be reinstalled in the original positions and directions.
- 6) Gaskets and lock washers must be replaced with new ones. Liquid gasket should be used where specified to prevent leakage.
- 7) Bolts, nuts and washers should be replaced with new ones as required.
- 8) Even if necessary inspections have been made in advance, proceed with assembly work while making rechecks.

**2. Hydraulic Lash Adjuster**

**A: INSPECTION**

- 1) Disconnect blow-by hose from rocker cover.
- 2) Remove spark plug cap.

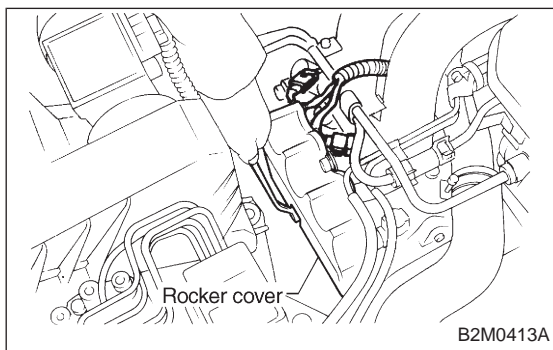

3) Remove left and right rocker covers.

**CAUTION:**

**Before removing left rocker cover, disconnect battery cables and generator cable.**

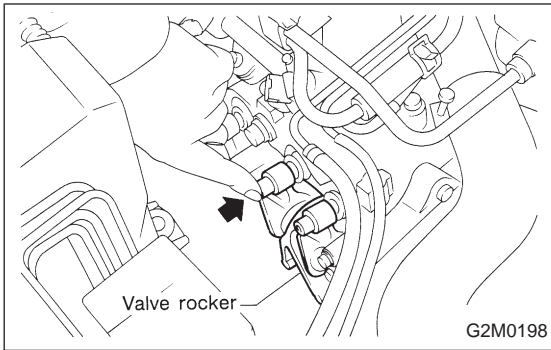

4) Manually push valve rocker (at lash adjuster location) to check that there is no air in it.

**NOTE:**

When air is in lash adjuster, valve rocker moves when pushed with fingers.

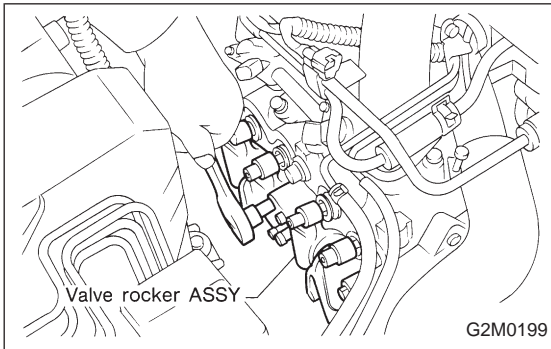

5) If air is in lash adjuster, remove valve rocker assembly from engine and bleed air completely.

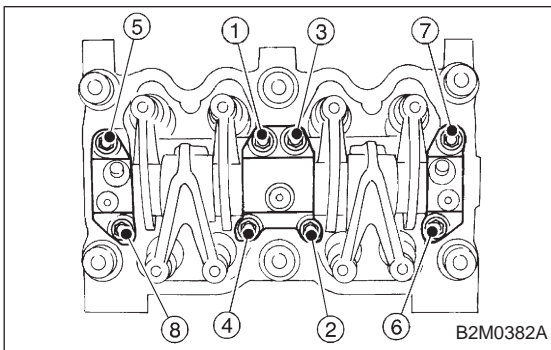

**B: AIR BLEEDING**

1) Remove valve rocker assembly.

(1) Remove bolts ① through ④ in numerical sequence.

**CAUTION:**

Leave two or three threads of bolt ① engaged to retain valve rocker assembly.

(2) Equally loosen bolts ⑤ through ⑧ all the way, being careful that knock pin is not gouged.

2) Manually remove lash adjusters where air is trapped.

**CAUTION:**

If lash adjuster is difficult to remove manually, use pliers. Be careful not to scratch lash adjuster.

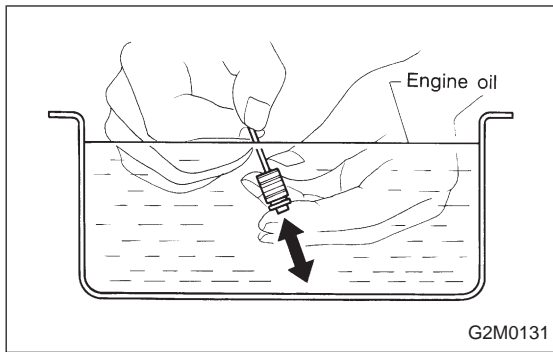

3) Bleed air from hydraulic lash adjuster as described below:

- (1) While dipping hydraulic lash adjuster in engine oil, as shown in Figure, push check ball in using a 2 mm (0.08 in) diameter round bar.
- (2) With check ball pushed in, manually move plunger up and down at one second intervals until air bubbles disappear.
- (3) After air bubbles disappear, remove round bar and quickly push plunger in to ensure it is locked. If plunger does not lock properly, replace hydraulic lash adjuster.

**CAUTION:**

**Leave hydraulic lash adjuster (after air is bled) in engine oil until it is ready for installation.**

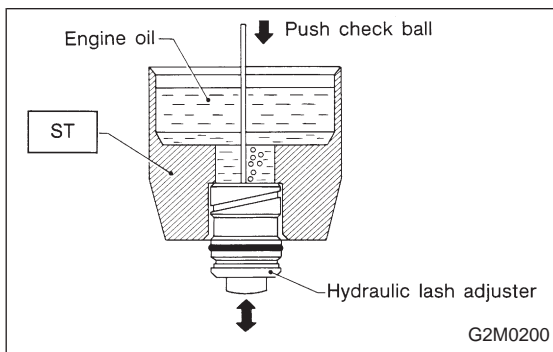

4) Using ST;

- (1) Insert lash adjuster into ST, and fill ST with engine oil. Using a 2 mm (0.08 in) diameter rod, push check ball in.

ST 499597000 OIL SEAL GUIDE

- (2) With check ball pushed in, push plunger at an interval of one second.
- (3) Move plunger up and down until air bubbles are no longer emitted from lash adjuster.

**NOTE:**

Hold hydraulic lash adjusters vertically during air bleeding.

5) Remove the rod. Push plunger to ensure that air is completely bled out.

**CAUTION:**

**If plunger does not properly lock (when pushed), replace lash adjuster with a new one.**

6) Fill rocker arm's oil reservoir with engine oil and install lash adjuster.

**CAUTION:**

- Do not rotate lash adjuster during installation.
- Be careful not to scratch the oil seal.

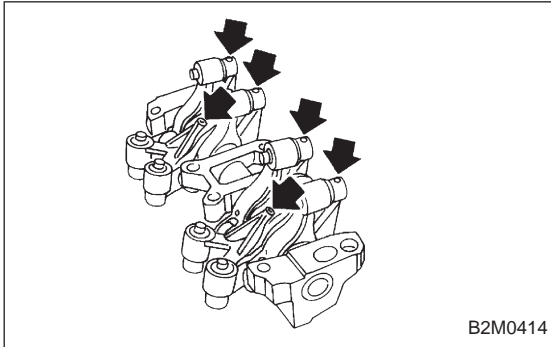

**CAUTION:**

When removing valve rocker assembly, keep the assembly soaked in engine oil, or position it with air bleeding orifice on rocker arm facing upward as shown. This prevents oil leakage from and air entering into the hydraulic lash adjuster. Failure to do so may cause air to enter the hydraulic lash adjuster, causing loss in performance.

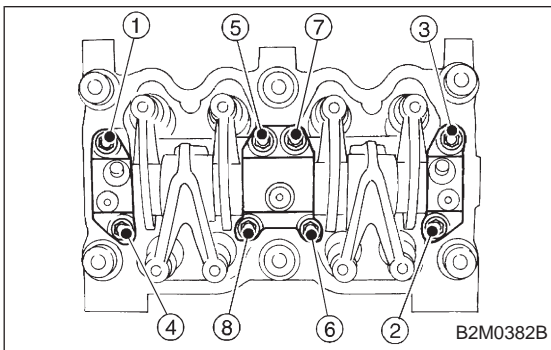

- 7) Temporarily and equally tighten bolts ① through ④. Do not allow knock pin to catch valve rocker assembly.
- 8) Tighten bolts ⑤ through ⑧ to specified torque.
- 9) Tighten bolts ① through ④ to specified torque.

**Tightening torque:**

**$12 \pm 1 \text{ N}\cdot\text{m}$  ( $1.2 \pm 0.1 \text{ kg}\cdot\text{m}$ ,  $8.7 \pm 0.7 \text{ ft}\cdot\text{lb}$ )**

10) Install rocker covers.

**Tightening torque:**

**$5 \pm 1 \text{ N}\cdot\text{m}$  ( $0.5 \pm 0.1 \text{ kg}\cdot\text{m}$ ,  $3.6 \pm 0.7 \text{ ft}\cdot\text{lb}$ )**

11) Connect harness connectors, hoses, etc. to their positions.

### 3. Timing Belt

#### A: REMOVAL

#### 1. CRANKSHAFT PULLEY AND BELT COVER

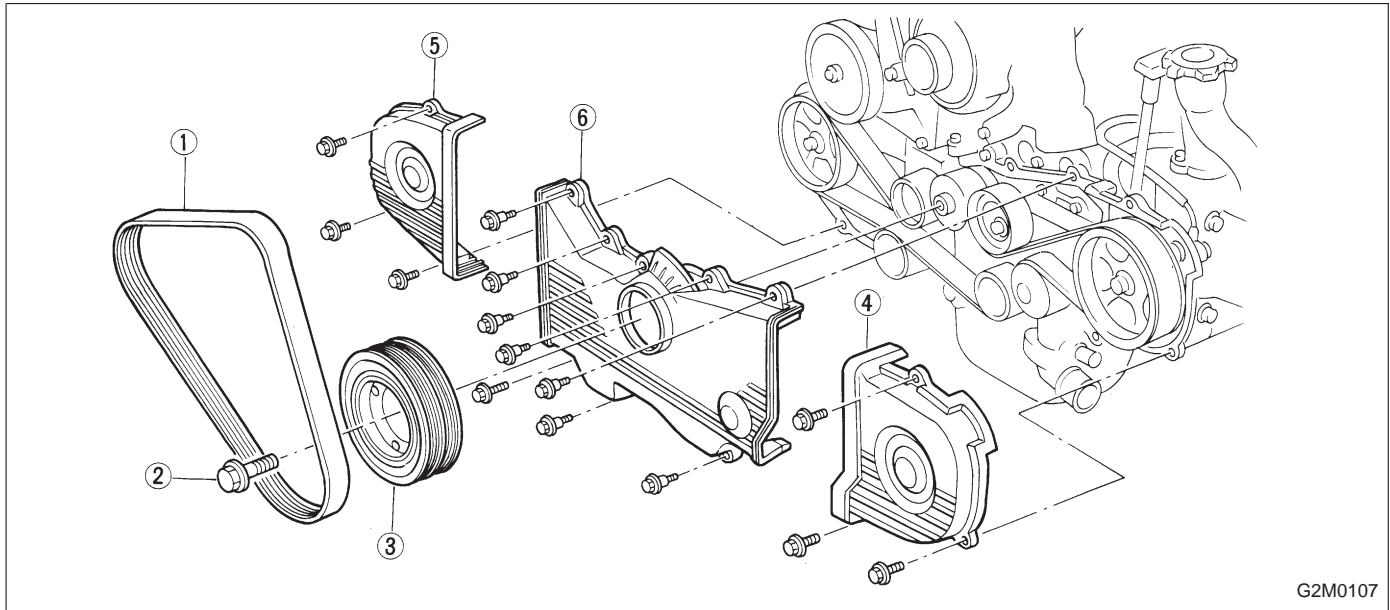

G2M0107

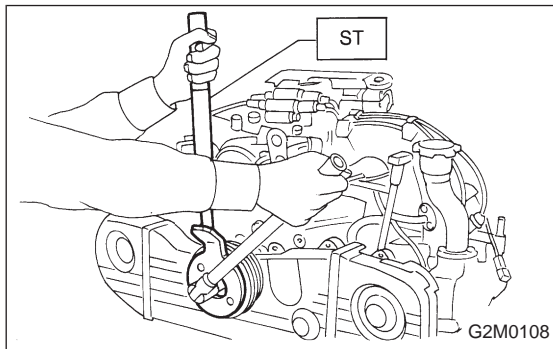

- 1) Remove V-belt and A/C belt tensioner.
- 2) Remove pulley bolt. To lock crankshaft use ST.  
ST 499977000 CRANKSHAFT PULLEY WRENCH
- 3) Remove crankshaft pulley.
- 4) Remove left side belt cover.
- 5) Remove right side belt cover.
- 6) Remove front belt cover.

2. TIMING BELT

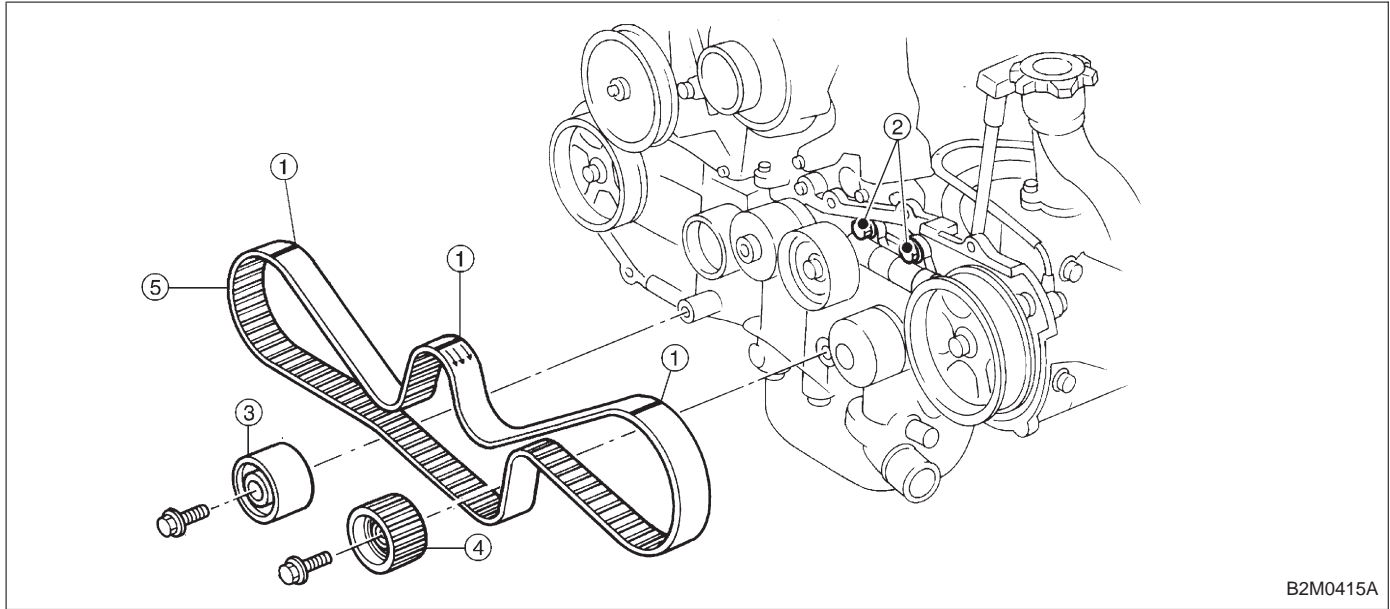

B2M0415A

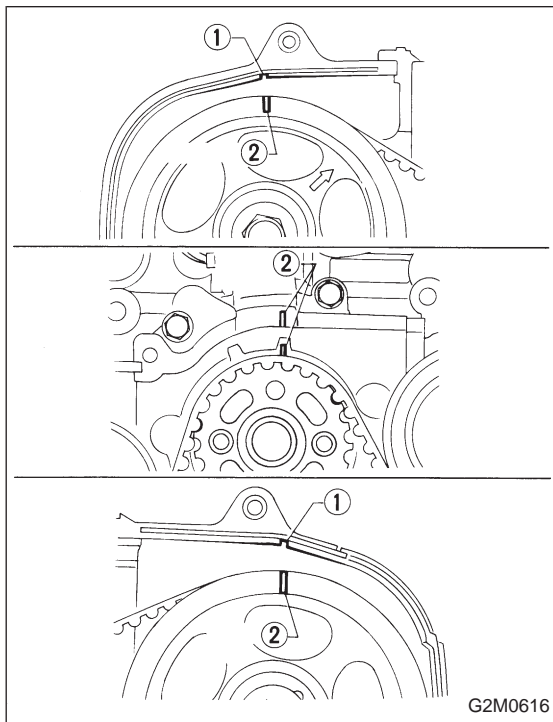

G2M0616

1) If alignment mark ② and/or arrow mark (which indicates rotation direction) on timing belt fade away, put new marks before removing timing belt as follows:

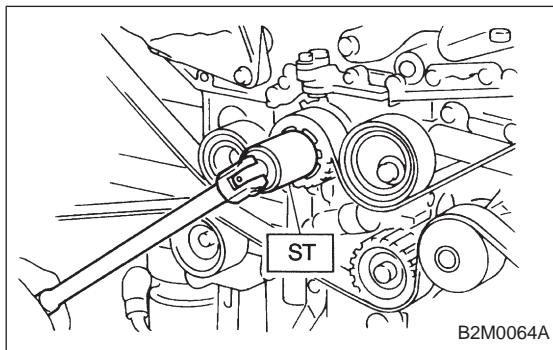

B2M0064A

(1) Turn crankshaft, and align alignment marks ② on crankshaft sprocket, and left and right camshaft sprockets with notches ① of belt cover and cylinder block.

ST 499987500 CRANKSHAFT SOCKET



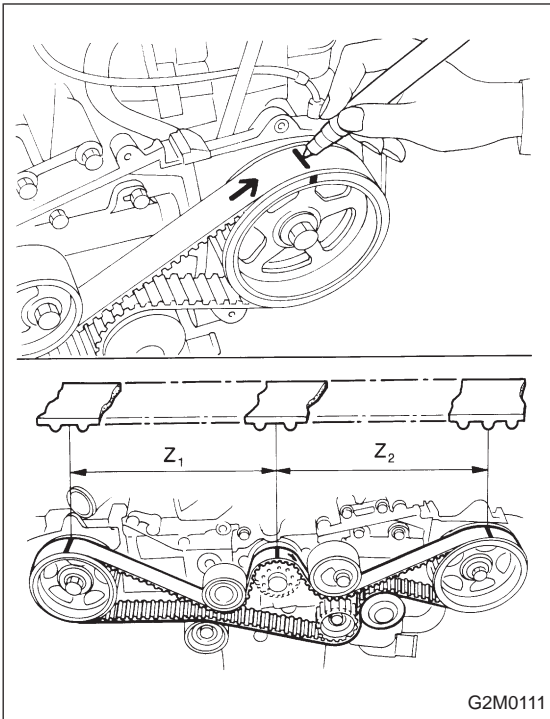

(2) Using white paint, put alignment and/or arrow marks on timing belts in relation to the sprockets.

**$Z_1$ : 44 tooth length**  
 **$Z_2$ : 40.5 tooth length**

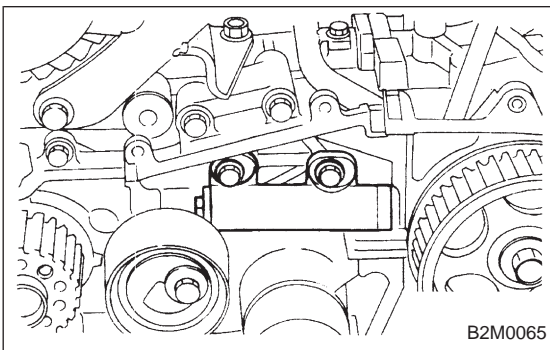

2) Loosen tensioner adjuster mounting bolts.

- 3) Remove belt idler.
- 4) Remove belt idler No. 2.
- 5) Remove timing belt.
- 6) Remove tensioner adjuster.

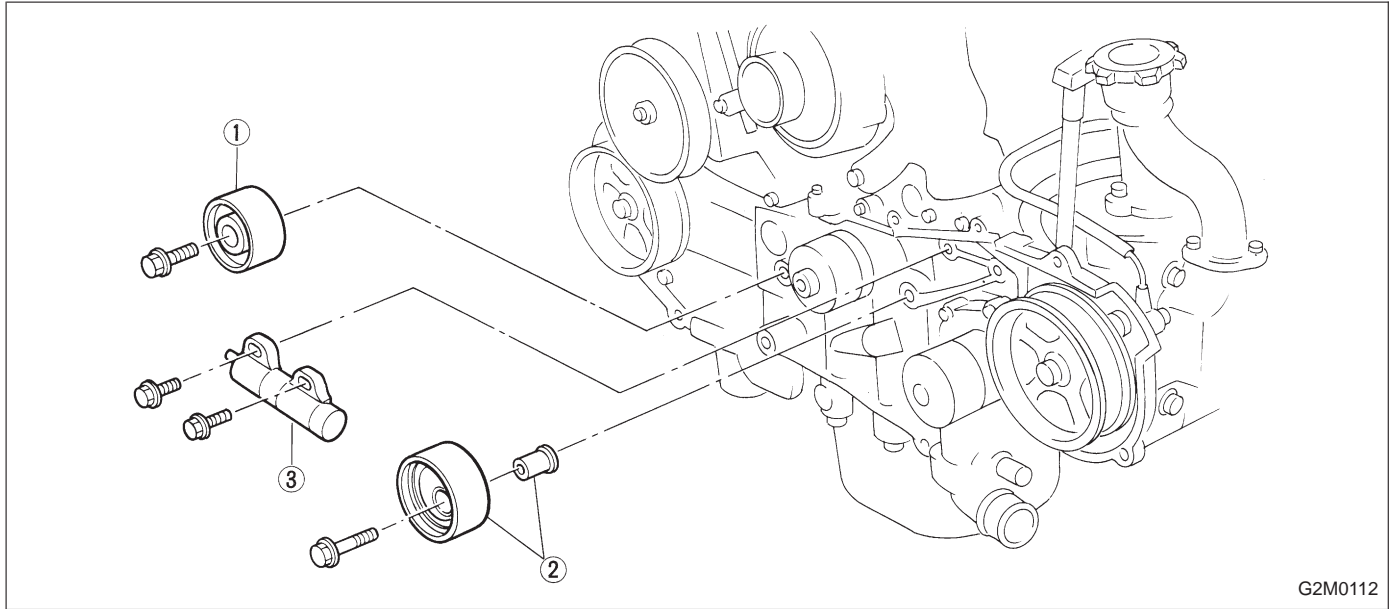
**3. BELT TENSIONER AND IDLER**

G2M0112

- 1) Remove belt idler.
- 2) Remove belt tensioner and spacer.
- 3) Remove belt tensioner adjuster.

## 4. SPROCKET

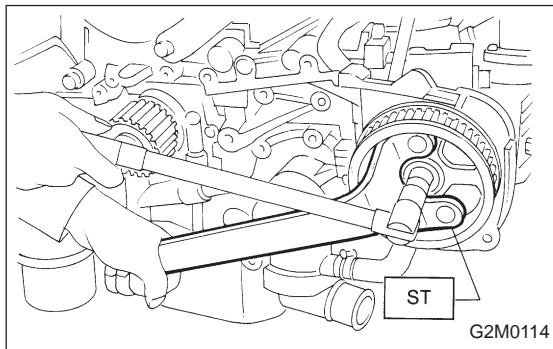
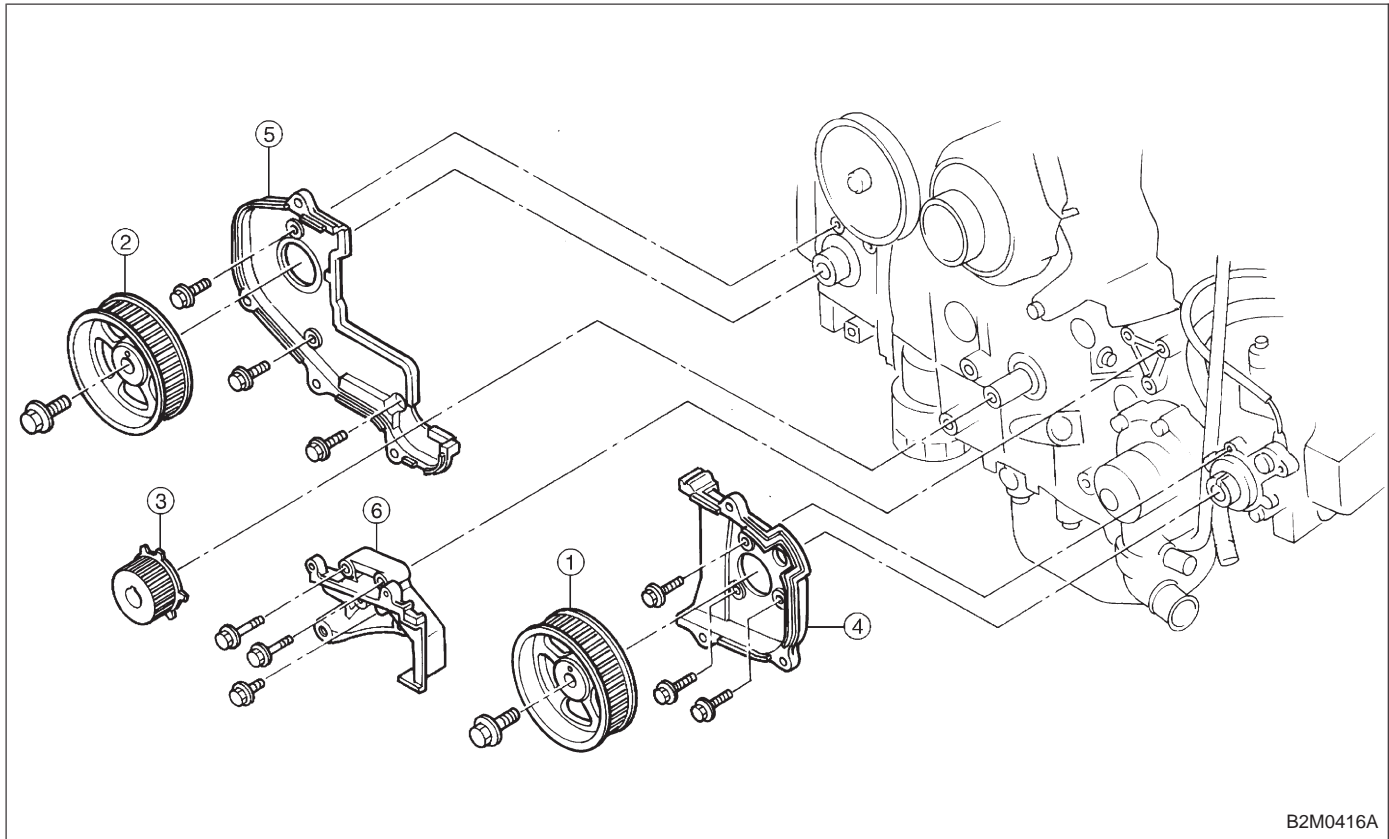

- 1) Remove left side camshaft sprocket.
- 2) Remove right side camshaft sprocket. To lock camshaft use ST.  
ST 499207100 CAMSHAFT SPROCKET WRENCH

- 3) Remove crankshaft sprocket.
- 4) Remove left side belt cover No. 2.
- 5) Remove right side belt cover No. 2.

**CAUTION:**

**Do not damage or lose the seal rubber when removing belt covers.**

- 6) Remove tensioner bracket.

**B: INSPECTION****1. TIMING BELT**

- 1) Check timing belt teeth for breaks, cracks, and wear. If any fault is found, replace belt.
- 2) Check the condition of back side of belt; if any crack is found, replace belt.

**CAUTION:**

- Be careful not to let oil, grease or coolant contact the belt. Remove quickly and thoroughly if this happens.

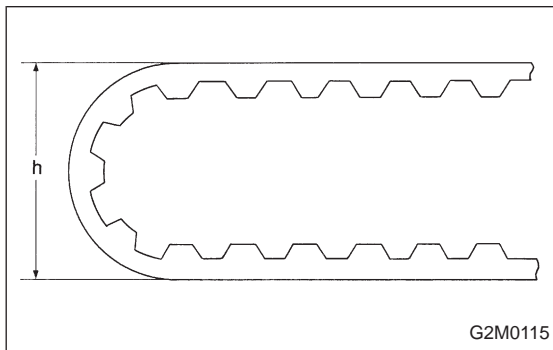

- Do not bend the belt sharply.

**Bending radius:  $h$**   
**60 mm (2.36 in) or more**

**2. BELT TENSION ADJUSTER**

- 1) Visually check oil seals for leaks, and rod ends for abnormal wear or scratches. If necessary, replace belt tension adjuster.

**CAUTION:**

**Slight traces of oil at rod's oil seal does not indicate a problem.**

- 2) While holding tensioner with both hands, push the rod section against floor or wall ensuring the rod section will react as follows:

- (1) When applying a force of 147 N (15 kg, 33 lb), the rod section should not sink.
- (2) When applying a force of 147 to 490 N (15 to 50 kg, 33 to 110 lb), the rod section should maintain a projectionally acting force and should not sink within 8.5 seconds.

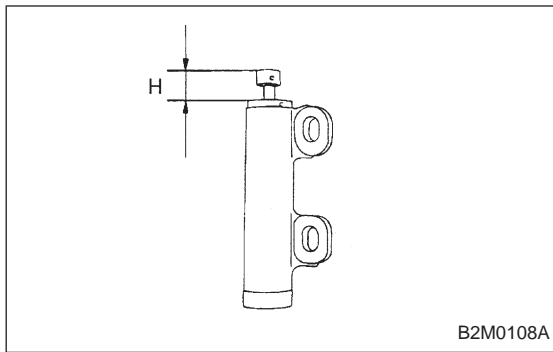

3) Measure the extension of rod beyond the body. If it is not within specifications, replace with a new one.

**Rod extension: *H***

**15.4 — 16.4 mm (0.606 — 0.646 in)**

### 3. BELT TENSIONER

- 1) Check mating surfaces of timing belt and contact point of tension adjuster rod for abnormal wear or scratches. Replace belt tensioner if faulty.
- 2) Check spacer and tensioner bushing for wear.
- 3) Check tensioner for smooth rotation. Replace if noise or excessive play is noted.
- 4) Check tensioner for grease leakage.

### 4. BELT IDLER

- 1) Check idler for smooth rotation. Replace if noise or excessive play is noted.
- 2) Check outer contacting surfaces of idler pulley for abnormal wear and scratches.
- 3) Check idler for grease leakage.

### 5. SPROCKET

- 1) Check sprocket teeth for abnormal wear and scratches.
- 2) Make sure there is no free play between sprocket and key.
- 3) Check crankshaft sprocket notch for sensor for damage and contamination of foreign matter.

## C: INSTALLATION

## 1. SPROCKET

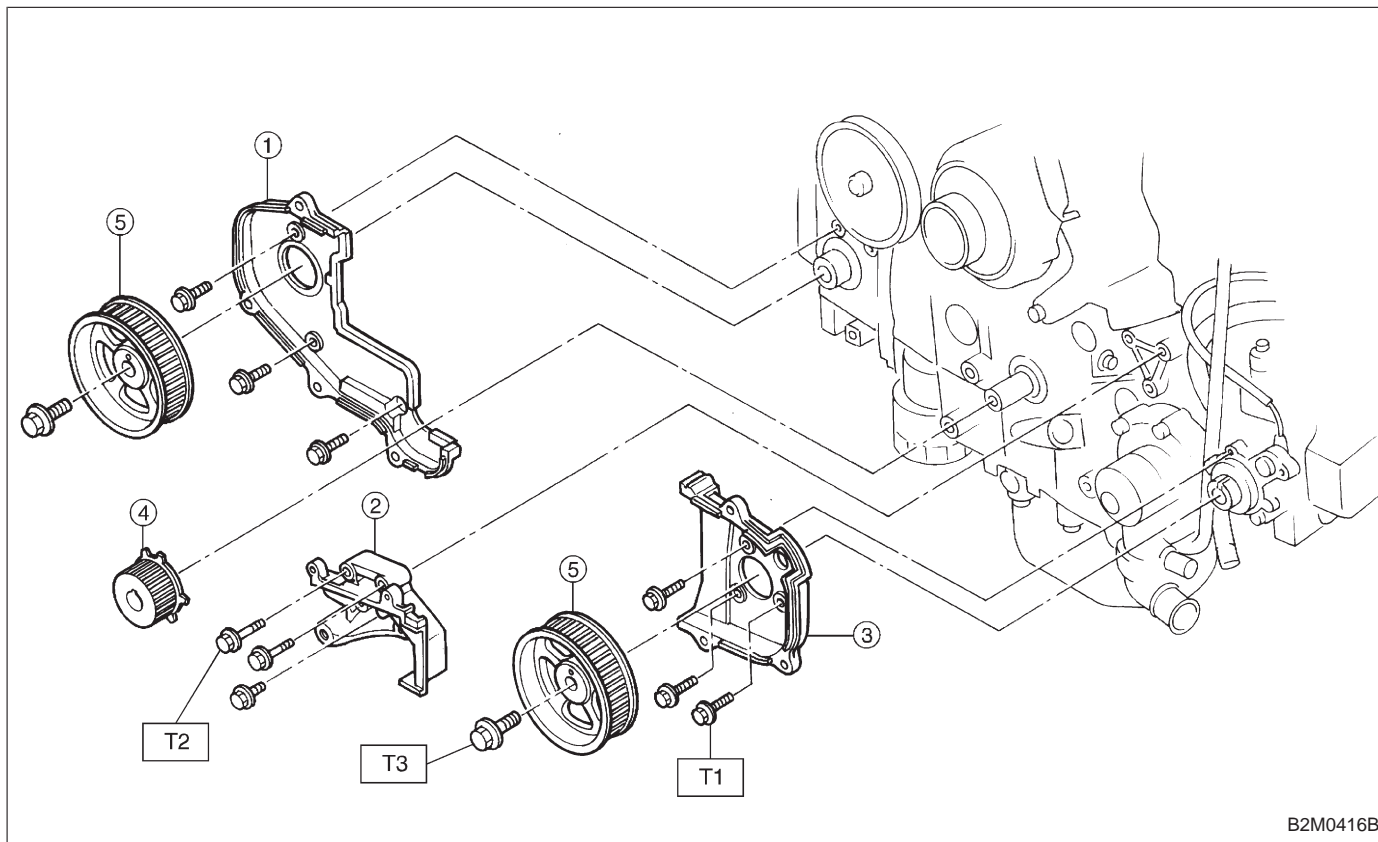

**Tightening torque: N·m (kg·m, ft·lb)**

**T1: 5±1 (0.5±0.1, 3.6±0.7)**

**T2: 25±2 (2.5±0.2, 18.1±1.4)**

**T3: 78±5 (8.0±0.5, 57.9±3.6)**

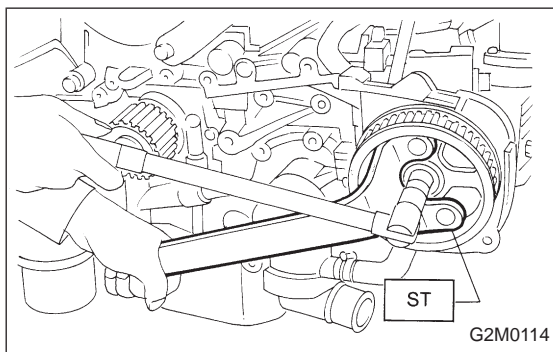

- 1) Install right side belt cover No. 2.
- 2) Install tensioner bracket.
- 3) Install left side belt cover No. 2.
- 4) Install crankshaft sprocket.
- 5) Install right side camshaft sprocket and left side camshaft sprocket. To lock camshaft use ST.

ST 499207100 CAMSHAFT SPROCKET WRENCH

**CAUTION:**

**Do not confuse left and right side camshaft sprockets during installation. The left side camshaft sprocket is identified by a projection used to monitor cam angle sensor.**

2. BELT TENSIONER AND IDLER

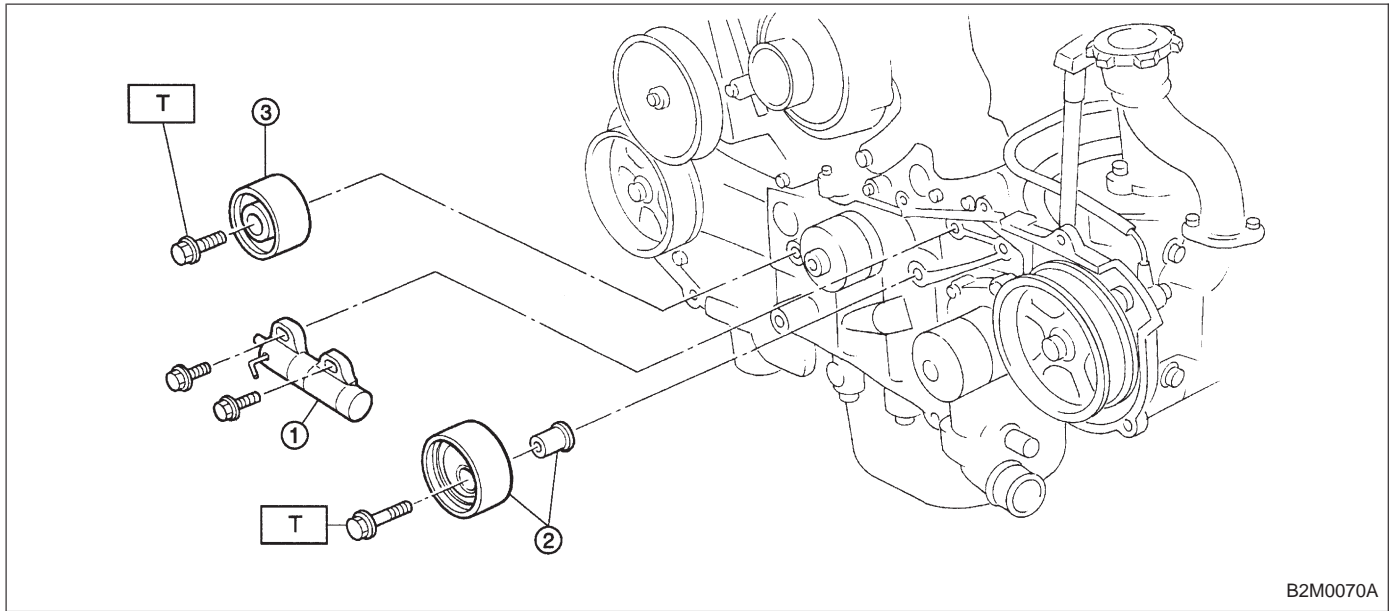

B2M0070A

Tightening torque: N·m (kg·m, ft·lb)  
T: 39±4 (4.0±0.4, 28.9±2.9)

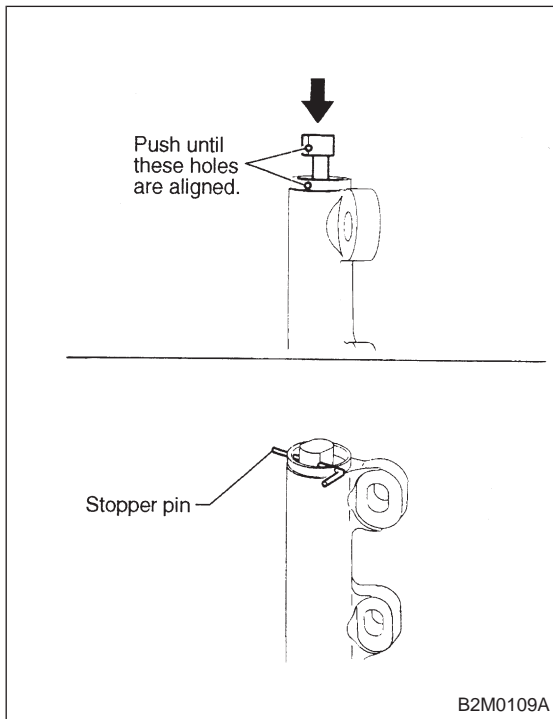

B2M0109A

1) Installation of belt tension adjuster  
Insert stopper pin 1.5 mm (0.059 in) diameter into place while pushing tension adjuster rod into body using a press.

**CAUTION:**

- Do not allow press pressure to exceed 9,807 N (1,000 kg, 2,205 lb).
- Do not release press pressure until stopper pin is completely inserted.
- Push tension adjuster rod vertically.
- Press-in the push rod gradually taking three minutes or more.

- 2) Install belt tensioner and spacer.
- 3) Install belt idler.

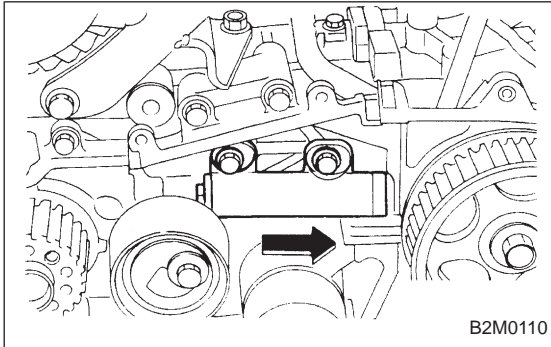

- 4) Temporarily tighten bolts while belt tension adjuster is pushed all the way to the right.

### 3. TIMING BELT

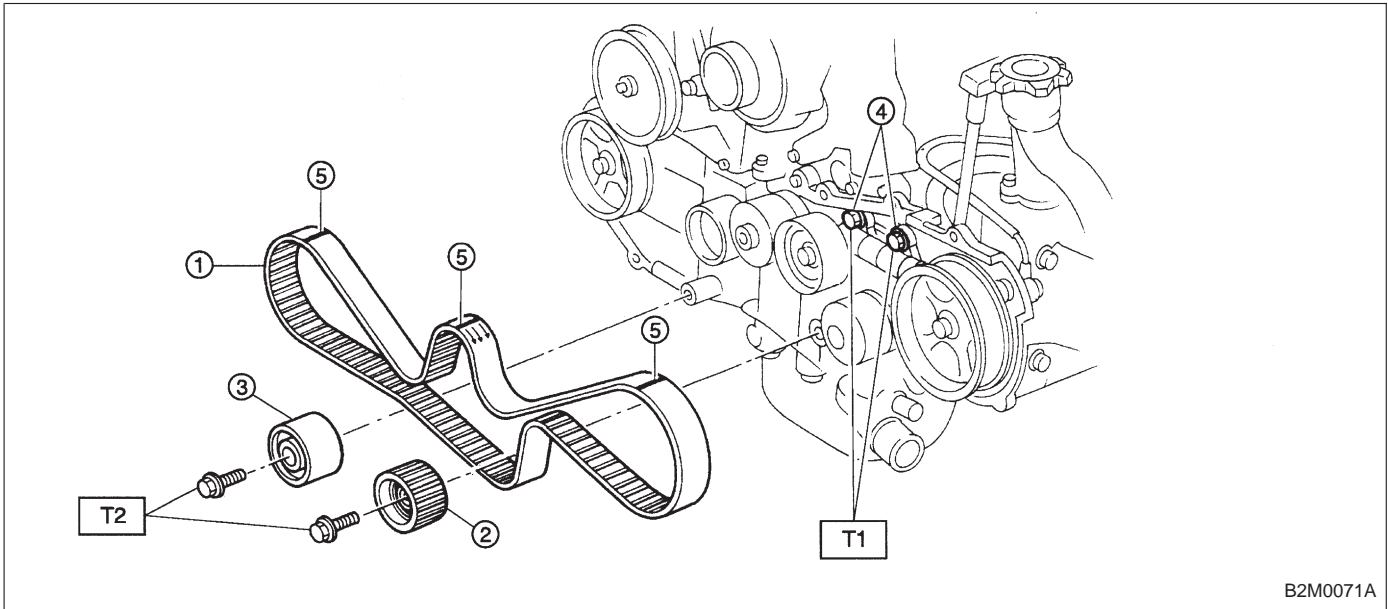

**Tightening torque: N·m (kg·m, ft·lb)**

**T1: 25±2 (2.5±0.2, 18.1±1.4)**

**T2: 39±4 (4.0±0.4, 28.9±2.9)**



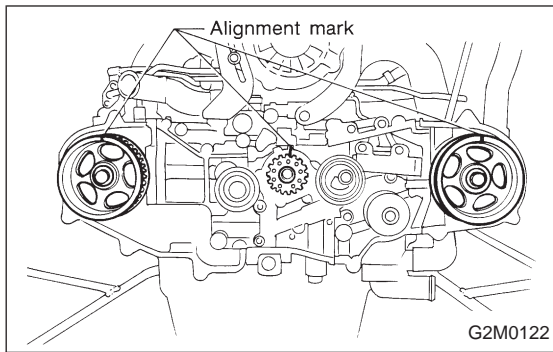

### 1) Installation of timing belt

(1) Using ST, turn left and right camshaft sprockets so that their alignment marks come to top positions.

ST 499207100 CAMSHAFT SPROCKET WRENCH

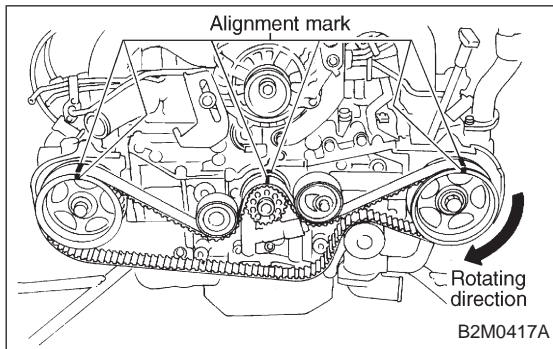

(2) While aligning alignment mark on timing belt with marks on sprockets, position timing belt properly.

### CAUTION:

Ensure belt's rotating direction is correct.

2) Install belt idler No. 2.

3) Install belt idler.

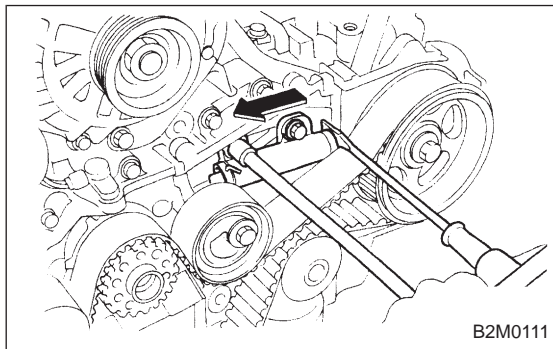

4) Loosen belt tension adjuster attaching bolts and move adjuster all the way to the left. Tighten the bolts.

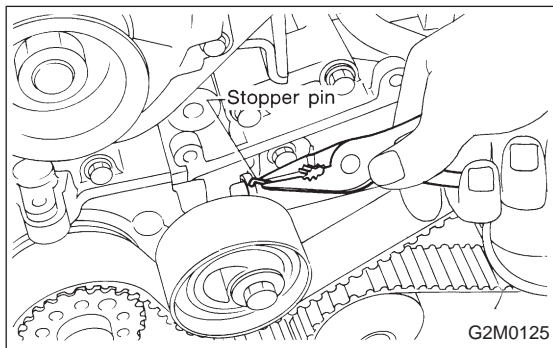

5) After ensuring that the marks on timing belt and camshaft sprockets are aligned, remove stopper pin from belt tension adjuster.

### CAUTION:

After properly installing timing belt, remove rocker cover and ensure that the valve lash adjuster contains no air.

## 4. CRANKSHAFT PULLEY AND BELT COVER

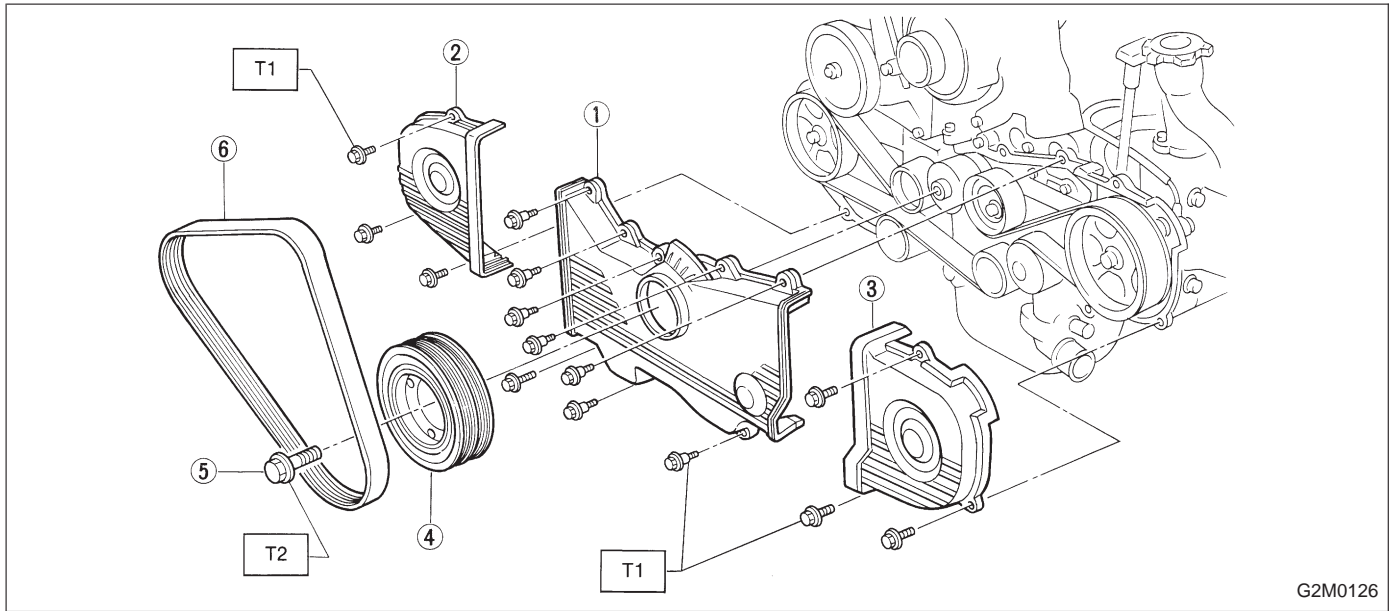

G2M0126

**Tightening torque: N·m (kg·m, ft·lb)**

**T1:  $5 \pm 1$  ( $0.5 \pm 0.1$ ,  $3.6 \pm 0.7$ )**

**T2:  $108^{+10}_{-5}$  ( $11^{+1.0}_{-0.5}$ ,  $79.6^{+7.2}_{-3.6}$ )**

- 1) Install front belt cover.
- 2) Install right side belt cover.
- 3) Install left side belt cover.
- 4) Install crankshaft pulley.

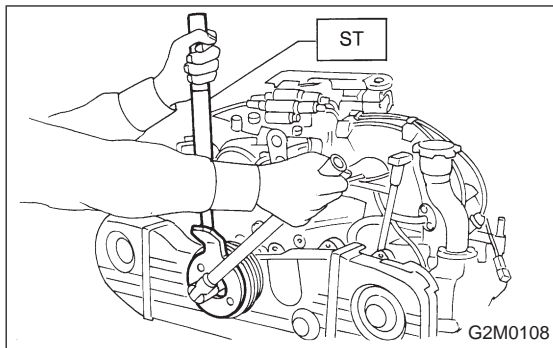

G2M0108

- 5) Install pulley bolt.  
To lock crankshaft, use ST.  
ST 499977000 CRANKSHAFT PULLEY WRENCH
- 6) Install V-belt.

### 4. Valve Rocker Assembly

#### A: REMOVAL

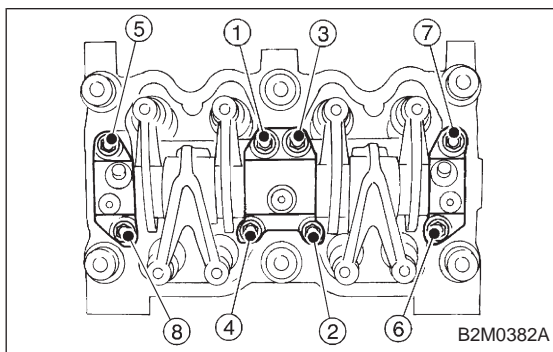
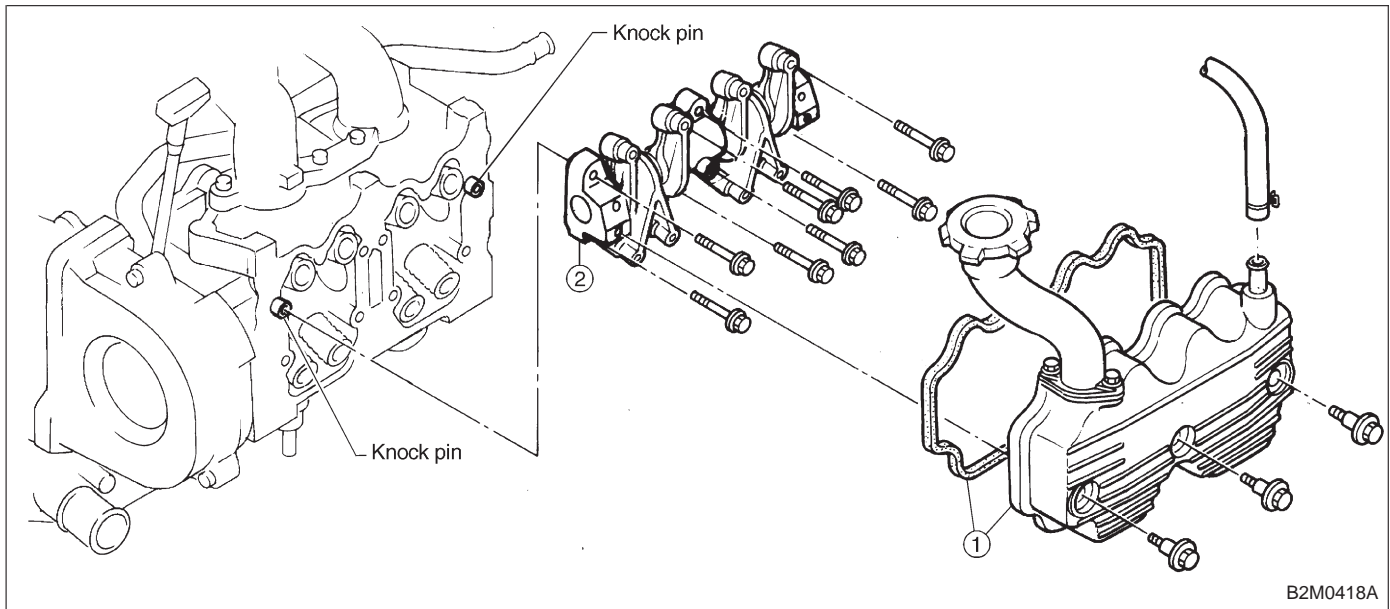

- 1) Disconnect PCV hose and remove rocker cover.
- 2) Removal of valve rocker assembly
  - (1) Remove bolts ① through ④ in numerical sequence.

**CAUTION:**  
 Leave two or three threads of bolt ① engaged to retain valve rocker assembly.

- (2) Equally loosen bolts ⑤ through ⑧ all the way, being careful that knock pin is not gouged.

- (3) Remove valve rocker assembly.

**CAUTION:**  
 Locate valve rocker assembly with air vent (on rocker arm) facing upward or dip it in engine oil after removal.

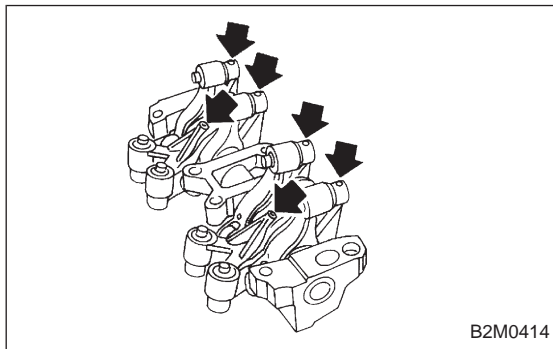

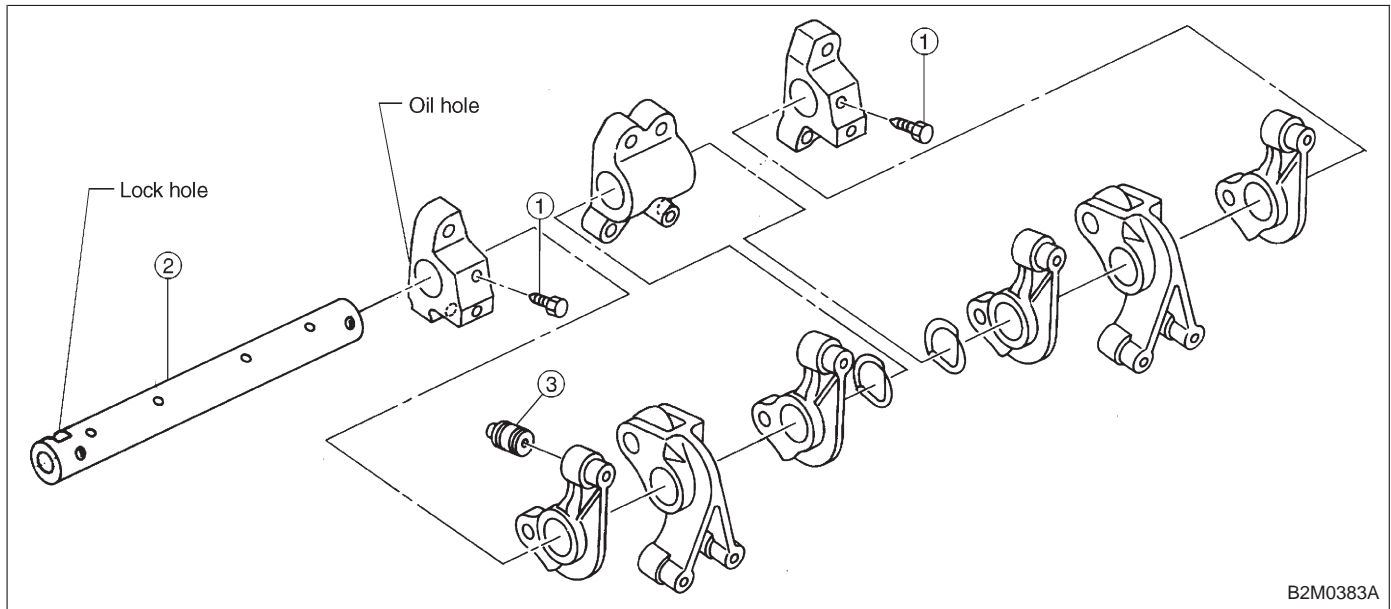
**B: DISASSEMBLY**

B2M0383A

- 1) Remove bolts which secure rocker shaft.
- 2) Extract rocker shaft. Remove valve rocker arms, springs and shaft supports from rocker shaft.

**CAUTION:**

- Arrange all removed parts in order so that they can be installed in their original positions.
- Locate rocker arms with air vents facing upward.

- 3) Remove valve lash adjuster from valve rocker.

**CAUTION:**

- Do not remove valve lash adjuster unless it requires air bleeding or replacement.
- If valve lash adjuster is hard to remove by hand, use pliers. Be careful not to scratch valve lash adjuster.
- Dip lash adjuster in engine oil after removal.

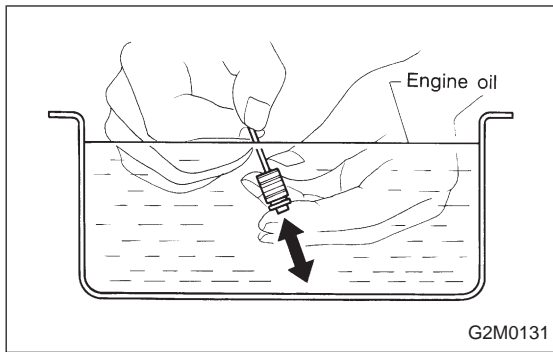

## C: INSPECTION

### 1. HYDRAULIC LASH ADJUSTER

1) Bleed air from hydraulic lash adjuster as described below:

- (1) While dipping hydraulic lash adjuster in engine oil, as shown in Figure, push check ball in using a 2 mm (0.08 in) diameter round bar.
- (2) With check ball pushed in, manually move plunger up and down at one second intervals until air bubbles disappear.
- (3) After air bubbles disappear, remove round bar and quickly push plunger in to ensure it is locked. If plunger does not lock properly, replace hydraulic lash adjuster.

#### **CAUTION:**

**Leave hydraulic lash adjuster (after air is bled) in engine oil until it is ready for installation.**

2) Replace hydraulic lash adjuster with a new one if valve contact surface is scratched.

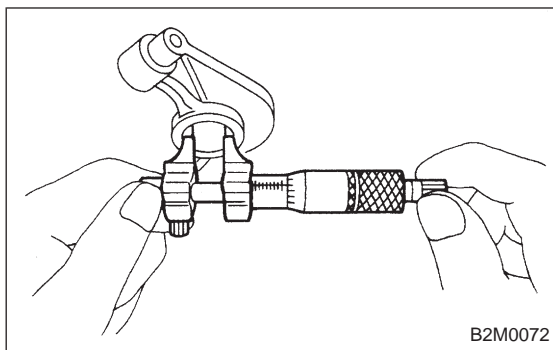

B2M0072

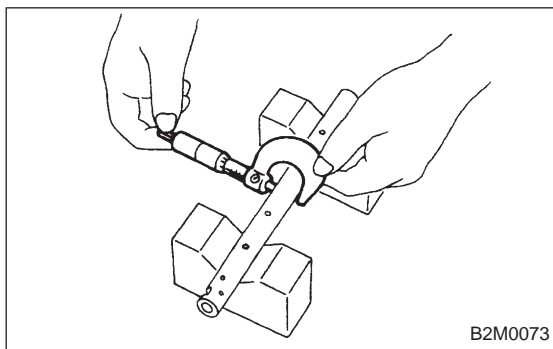

B2M0073

## 2. VALVE ROCKER ARM

1) Measure inside diameter of valve rocker arm and outside diameter of valve rocker shaft, and determine the difference between the two (= oil clearance).

### **Clearance between arm and shaft:**

#### **Standard**

**0.020 — 0.054 mm (0.0008 — 0.0021 in)**

#### **Limit**

**0.10 mm (0.0039 in)**

If oil clearance exceeds specifications, replace valve rocker arm or shaft.

#### **NOTE:**

Replace valve rocker arm or shaft, whichever shows greater amount of wear.

#### **Rocker arm inside diameter:**

**22.020 — 22.041 mm (0.8669 — 0.8678 in)**

#### **Rocker shaft diameter:**

**21.987 — 22.000 mm (0.8656 — 0.8661 in)**

2) Measure inside diameter of rocker shaft support and outside diameter of valve rocker shaft, and determine the difference between the two (= oil clearance).

### **Clearance between support and shaft:**

#### **Standard**

**0.005 — 0.039 mm (0.0002 — 0.0015 in)**

#### **Limit**

**0.05 mm (0.0020 in)**

If oil clearance exceeds specifications, replace rocker shaft support or shaft.

#### **NOTE:**

Replace rocker shaft support or shaft, whichever shows greater amount of wear.

#### **Rocker shaft support inside diameter:**

**22.005 — 22.026 mm (0.8663 — 0.8672 in)**

#### **Rocker shaft diameter:**

**21.987 — 22.000 mm (0.8656 — 0.8661 in)**

3) If cam or valve contact surface of valve rocker arm is worn or dented excessively, replace valve rocker arm.

4) Check that valve rocker arm roller rotates smoothly. If not, replace valve rocker arm.

## 3. VALVE ROCKER SHAFT

Visually check oil relief valve of shaft end for any of the following abnormalities.

- Breaks in check ball body
- Foreign particles caught in valve spring
- Oil leakage at check ball

#### **CAUTION:**

**Repair or replace valve rocker shaft as necessary.**

## D: ASSEMBLY

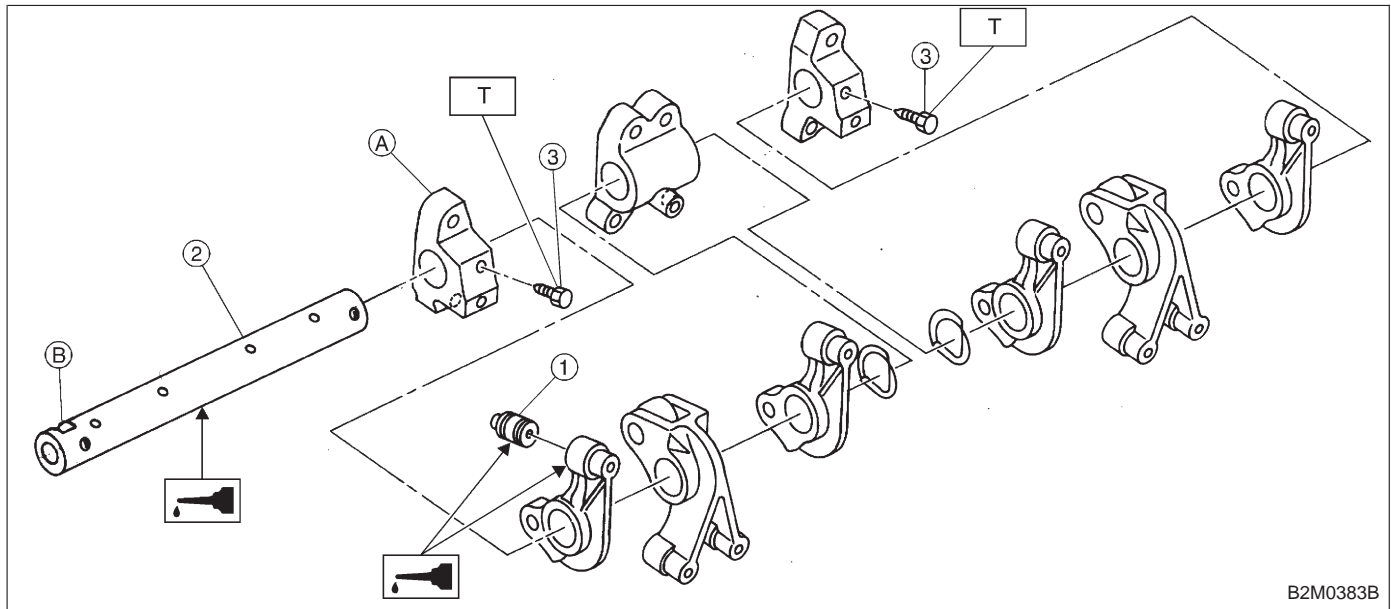

B2M0383B

**Tightening torque: N·m (kg·m, ft·lb)**  
**T: 5±1 (0.5±0.1, 3.6±0.7)**

1) After bleeding air from hydraulic lash adjuster, position hydraulic lash adjuster in valve rocker arm while dipping in engine oil.

**CAUTION:**

- Fill rocker arm oil reservoir chamber with engine oil.
- Install a new hydraulic lash adjuster O-ring, being careful not to scratch it.
- Do not attempt to rotate hydraulic lash adjuster during installation.

2) Arrange valve rocker arms, springs and shaft supports in assembly order and insert valve rocker shaft. Ensure that cutout portion of rocker shaft faces oil holes (A) in shaft supports.

**CAUTION:**

Valve rocker arms, rocker shaft and shaft supports have identification marks. Ensure parts with same markings are properly assembled.

3) Install valve rocker shaft securing bolts while aligning shaft "lock" holes (B) with bolts.

## E: INSTALLATION

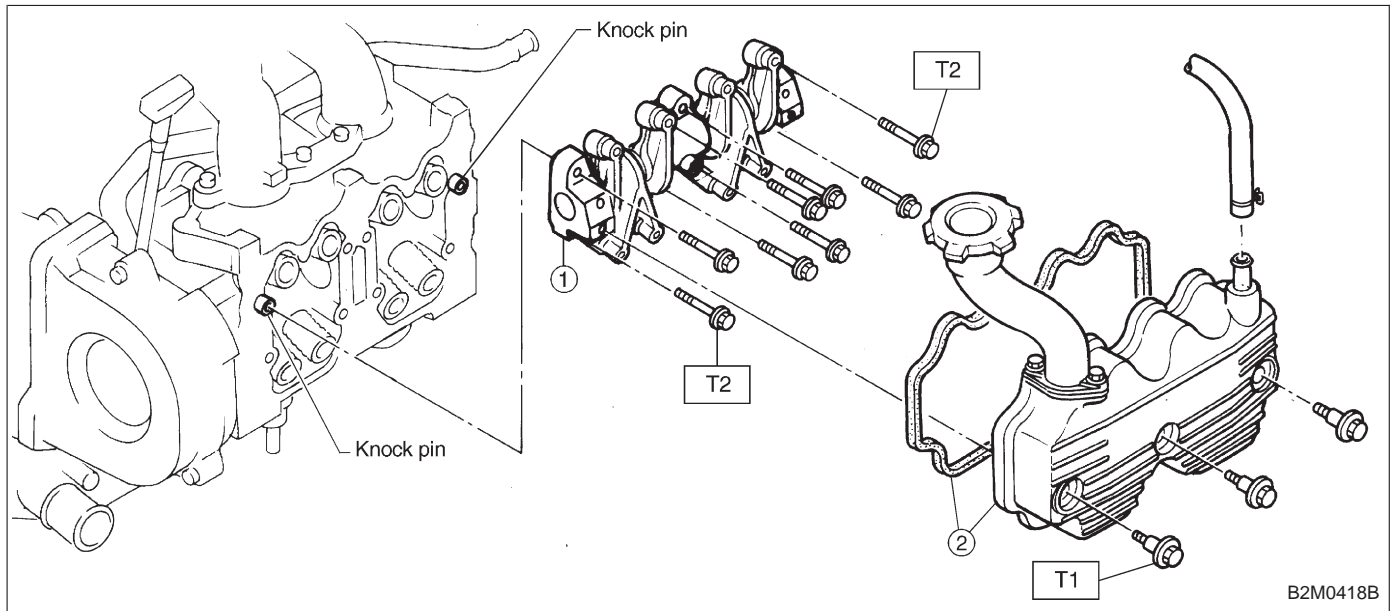

**Tightening torque: N·m (kg·m, ft·lb)**

**T1: 5±1 (0.5±0.1, 3.6±0.7)**

**T2: 12±1 (1.2±0.1, 8.7±0.7)**

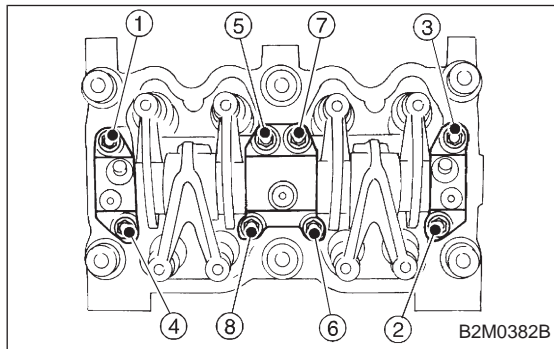

## 1) Installation of valve rocker assembly

(1) Temporarily tighten bolts ① through ④ equally as shown in Figure.

**CAUTION:**

**Do not allow valve rocker assembly to gouge knock pins.**

(2) Tighten bolts ⑤ through ⑧ to specified torque.

(3) Tighten bolts ① through ④ to specified torque.

## 2) Install rocker cover and connect PCV hose.



## 5. Camshaft

### A: REMOVAL

#### 1. RELATED PARTS

1) Remove timing belt, camshaft sprockets and related parts.

<Ref. to 2-3 [W3A1].>

2) Remove valve rocker assembly.

<Ref. to 2-3 [W4A0].>

#### 2. CAMSHAFT LH

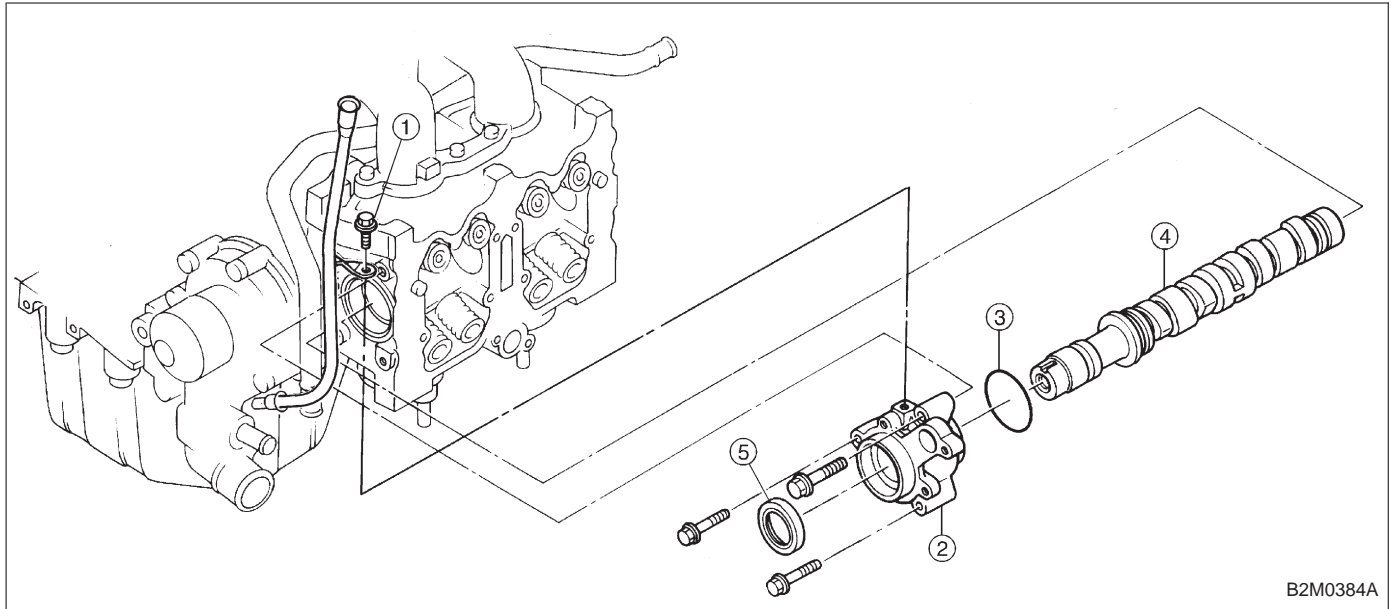

1) Remove oil level gauge guide attaching bolt.

2) Remove camshaft support LH.

#### CAUTION:

**Do not damage the camshaft position sensor.**

3) Remove O-ring.

4) Remove camshaft LH.

5) Remove oil seal.

#### CAUTION:

● **Do not remove oil seal unless necessary.**

● **Do not scratch journal surface when removing oil seal.**

## 3. CAMSHAFT RH

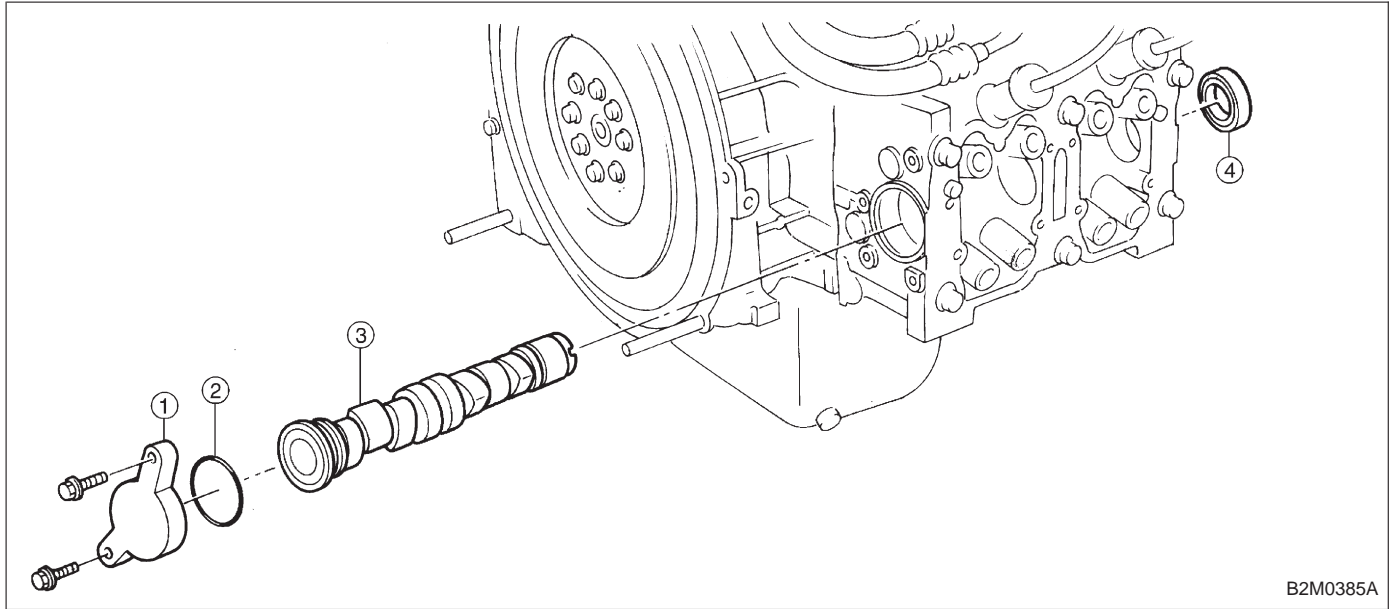

B2M0385A

- 1) Remove camshaft support RH.
- 2) Remove O-ring.
- 3) Remove camshaft.
- 4) Remove oil seal.

**CAUTION:**

- Do not remove oil seal unless necessary.
- Do not scratch journal surface when removing oil seal.

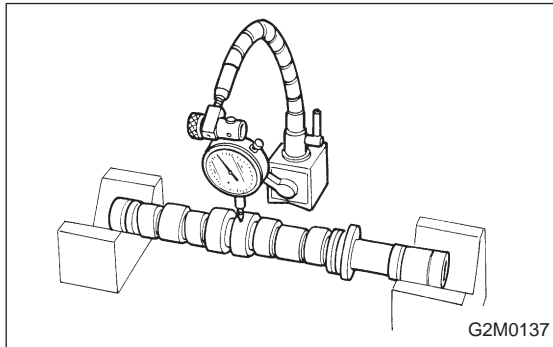

G2M0137

**B: INSPECTION****1. CAMSHAFT**

- 1) Measure the bend, and repair or replace if necessary.

**Limit:****0.025 mm (0.0010 in)**

- 2) Check journal for damage and wear. Replace if faulty.

3) Measure outside diameter of camshaft journal and inside diameter of cylinder head journal, and determine the difference between the two (= oil clearance). If oil clearance exceeds specifications, replace camshaft or cylinder head as necessary.

Unit: mm (in)

Item	Right-hand camshaft	Front	Center	Rear
	Left-hand camshaft	Rear	Center	Front
Clearance at journal	Standard	0.055 — 0.090 (0.0022 — 0.0035 )		
	Limit	0.10 (0.0039 )		
Camshaft journal O.D.		31.935 — 31.950 (1.2573 — 1.2579 )	37.435 — 37.450 (1.4738 — 1.4744 )	37.935 — 37.950 (1.4935 — 1.4941 )
Journal hole I.D.		32.005 — 32.025 (1.2600 — 1.2608 )	37.505 — 37.525 (1.4766 — 1.4774 )	38.005 — 38.025 (1.4963 — 1.4970 )

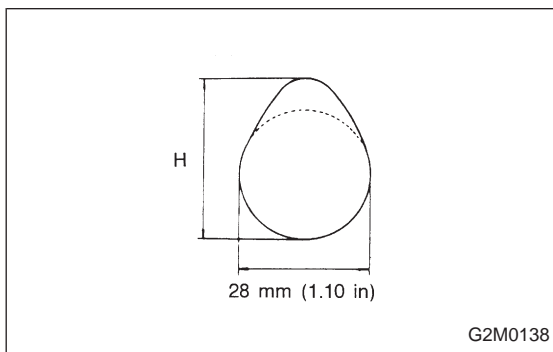

4) Check cam face condition; remove minor faults by grinding with oil stone. Measure the cam height H; replace if the limit has been exceeded.

**Cam height: H**

**Standard**

**IN: 31.994 — 32.094 mm (1.2596 — 1.2635 in)**

**EX: 32.624 — 32.724 mm (1.2844 — 1.2883 in)**

**Limit**

**IN: 31.844 mm (1.2537 in)**

**EX: 32.474 mm (1.2785 in)**

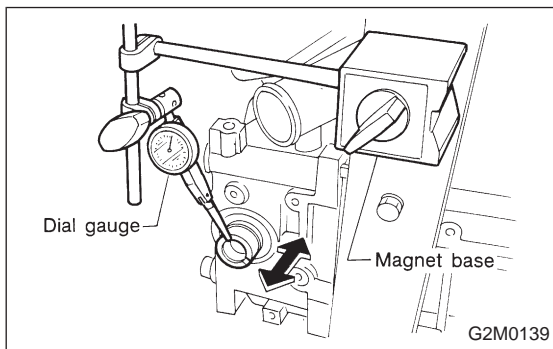

**2. CAMSHAFT SUPPORT**

Measure the thrust clearance of camshaft with dial gauge. If the clearance exceeds the limit, replace camshaft support.

**Standard:**

**0.030 — 0.260 mm (0.0012 — 0.0102 in)**

**Limit:**

**0.35 mm (0.0138 in)**

C: INSTALLATION

1. CAMSHAFT LH

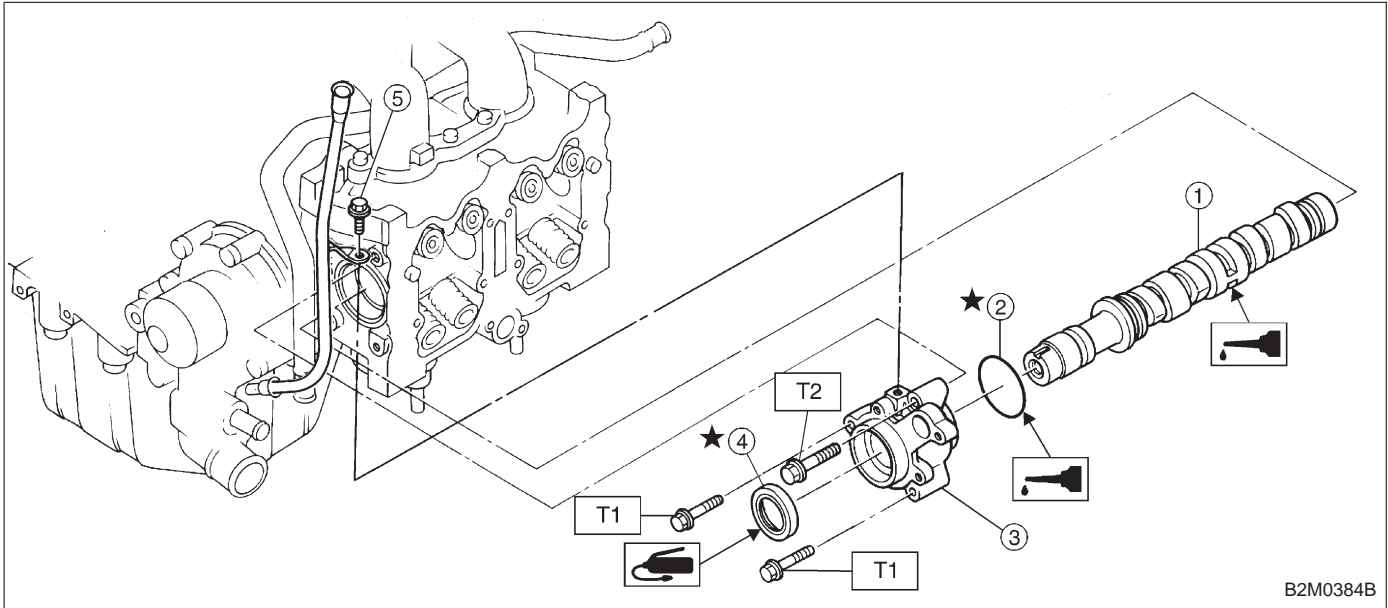

**Tightening torque: N·m (kg·m, ft·lb)**  
T1: 10 (1.0, 7)  
T2: 16 (1.6, 12)

- 1) Apply a coat of engine oil to camshaft journals and install camshaft LH.
- 2) Apply a coat of engine oil or grease to O-ring.
- 3) Install O-ring to camshaft support.

**CAUTION:**

**Use a new O-ring.**

- 4) Install camshaft support.

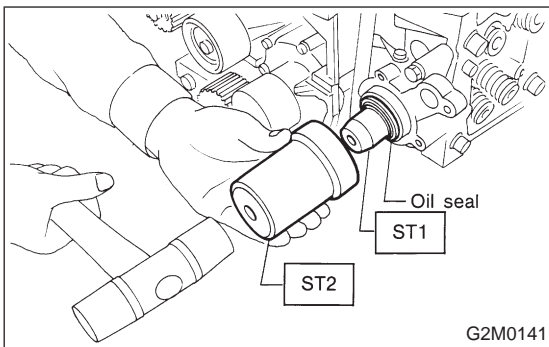

- 5) Apply a coat of grease to oil seal lips and install oil seal on camshaft support by using ST1 and ST2.

**CAUTION:**

**Use a new oil seal.**

ST1 499597000 OIL SEAL GUIDE  
ST2 499587100 OIL SEAL INSTALLER

- 6) Install oil level gauge guide bolt.

2. CAMSHAFT RH

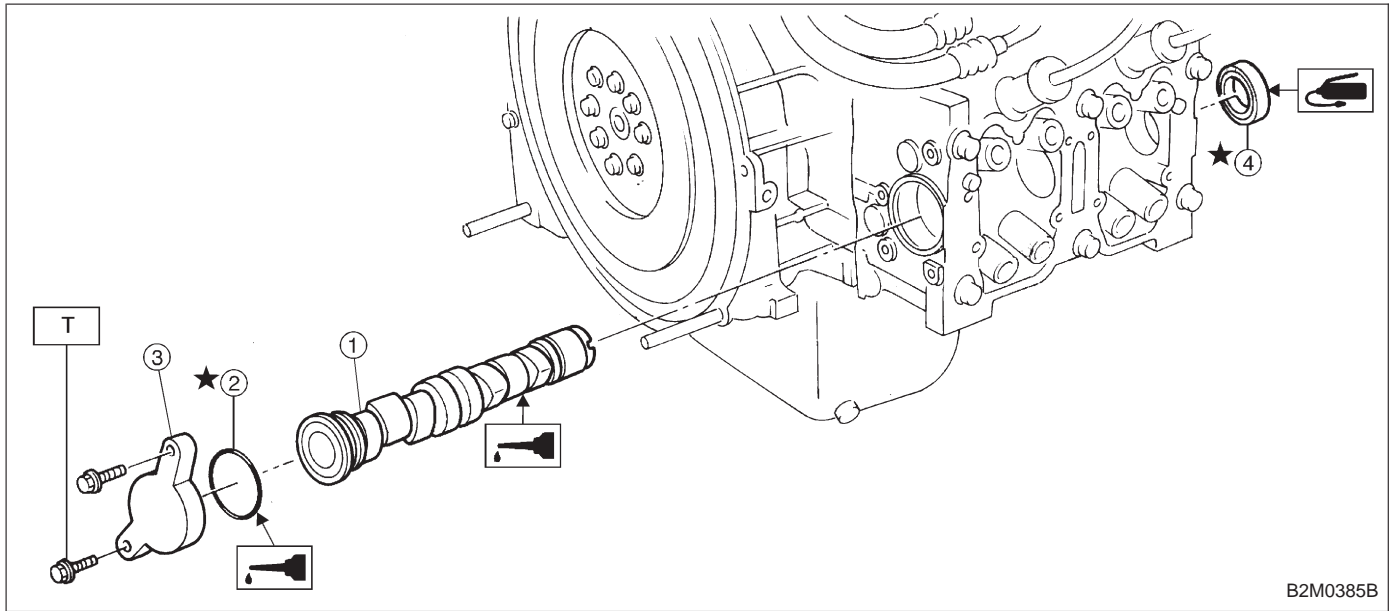

**Tightening torque: N·m (kg·m, ft·lb)**  
**T: 16 (1.6, 12)**

- 1) Apply a coat of engine oil to camshaft journals and install camshaft RH.
- 2) Apply a coat of engine oil or grease to O-ring.
- 3) Install O-ring to camshaft support.

**CAUTION:**

**Use a new O-ring.**

- 4) Install camshaft support.

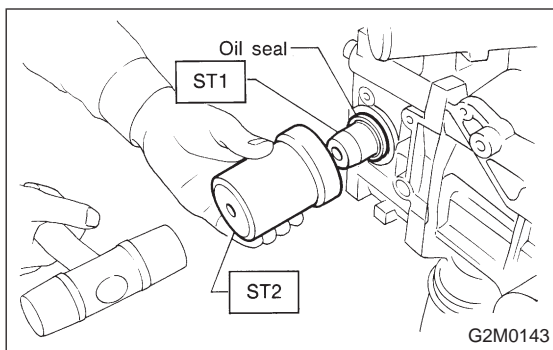

- 5) Install oil seal by using ST1 and ST2.

**CAUTION:**

**Use a new oil seal.**

ST1	499597000	OIL SEAL GUIDE
ST2	499587100	OIL SEAL INSTALLER

**3. RELATED PARTS**

- 1) Install valve rocker assembly.  
<Ref. to 2-3 [W4E0].>

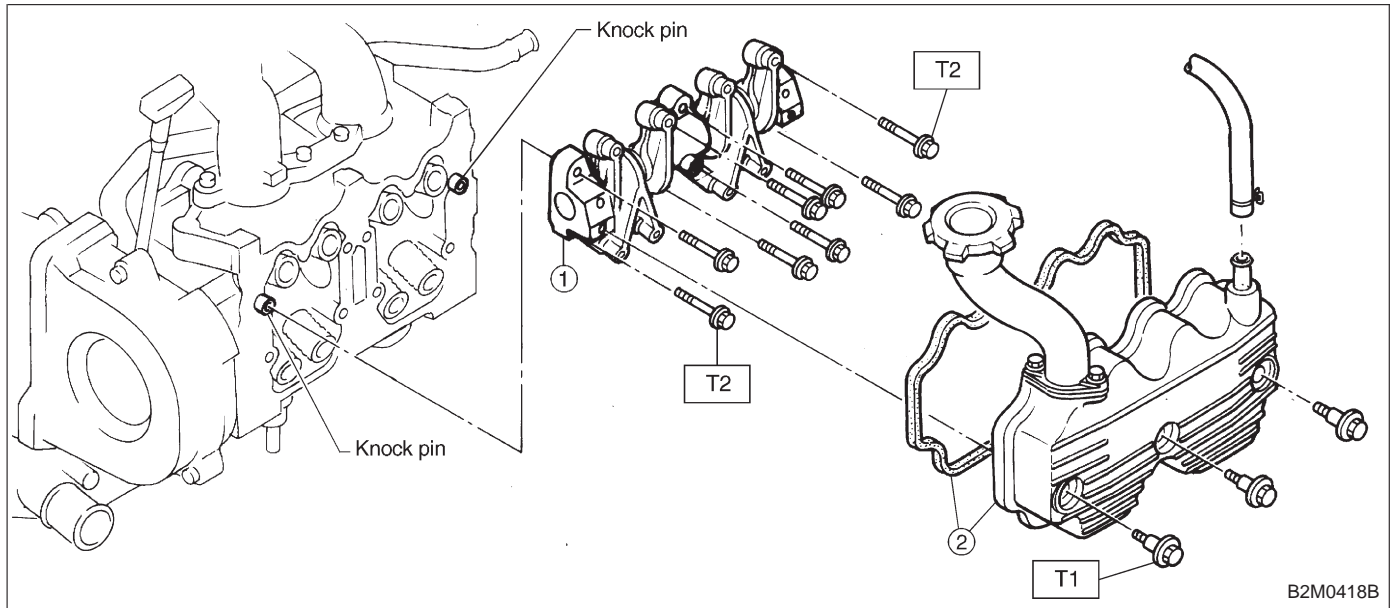

**Tightening torque: N·m (kg·m, ft·lb)**

**T1: 5±1 (0.5±0.1, 3.6±0.7)**

**T2: 12±1 (1.2±0.1, 8.7±0.7)**

- 2) Install timing belt, camshaft sprockets and related parts.  
<Ref. to 2-3 [W3C1].>

**6. Cylinder Head****A: REMOVAL****1. INTAKE MANIFOLD**

- 1) Release fuel pressure. <Ref. to 2-8 [W1A0].>
- 2) Drain engine coolant. <Ref. to 2-5 [W1A0].>
- 3) Remove intake manifold. <Ref. to 2-7 [W4A0].>
- 4) Remove engine coolant pipe.

**3. RELATED PARTS**

- 1) Install valve rocker assembly.  
<Ref. to 2-3 [W4E0].>

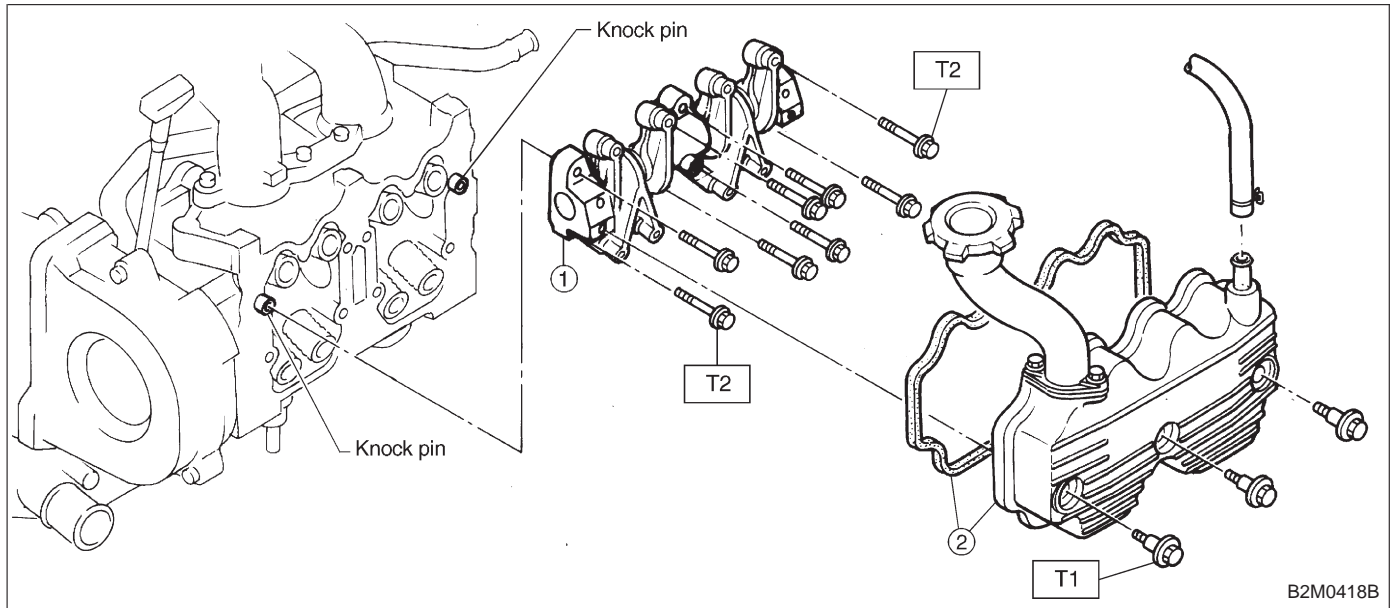

**Tightening torque: N·m (kg·m, ft·lb)**

**T1: 5±1 (0.5±0.1, 3.6±0.7)**

**T2: 12±1 (1.2±0.1, 8.7±0.7)**

- 2) Install timing belt, camshaft sprockets and related parts.  
<Ref. to 2-3 [W3C1].>

**6. Cylinder Head****A: REMOVAL****1. INTAKE MANIFOLD**

- 1) Release fuel pressure. <Ref. to 2-8 [W1A0].>
- 2) Drain engine coolant. <Ref. to 2-5 [W1A0].>
- 3) Remove intake manifold. <Ref. to 2-7 [W4A0].>
- 4) Remove engine coolant pipe.

## 2. CYLINDER HEAD

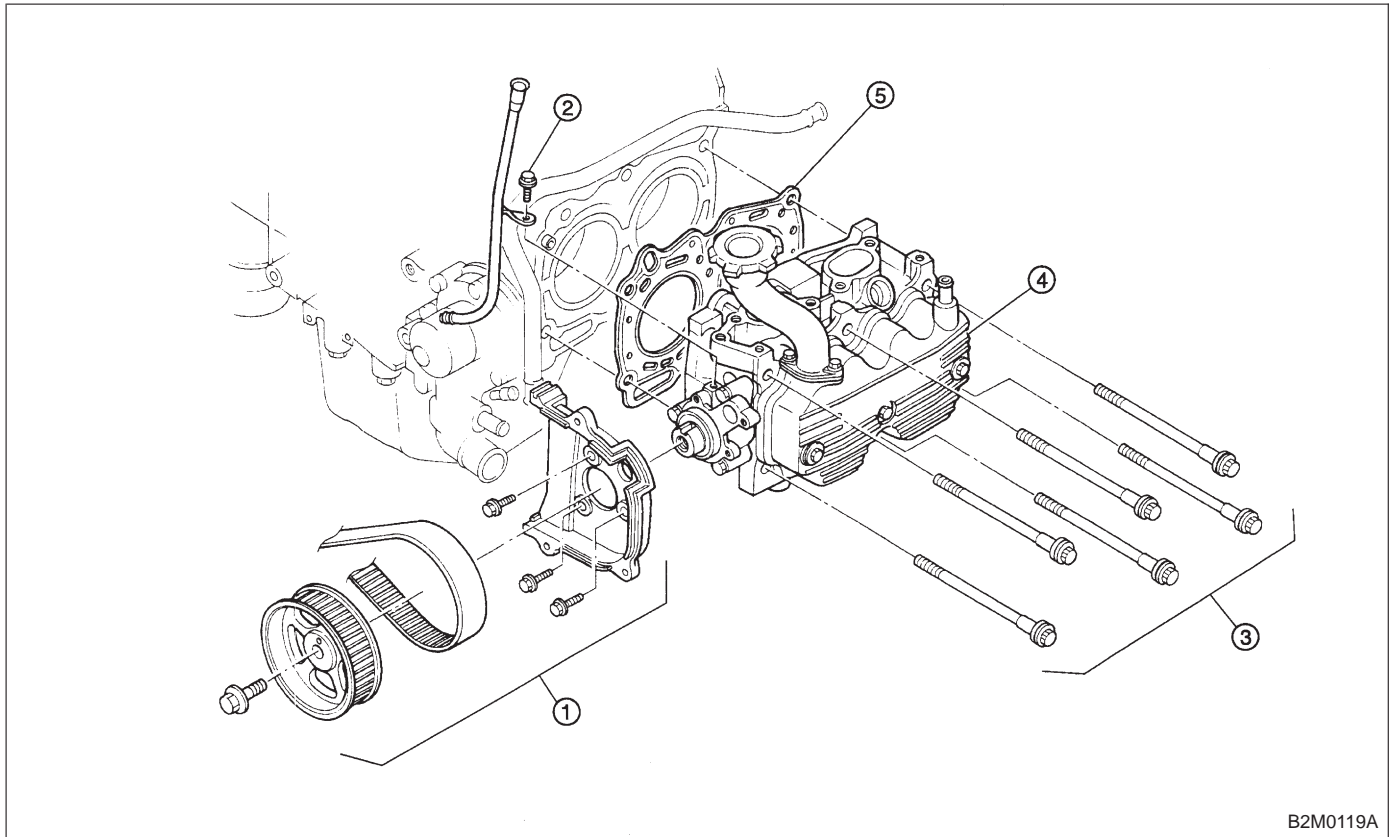

B2M0119A

1) Remove timing belt, camshaft sprocket and related parts.

<Ref. to 2-3 [W3A1].>

2) Remove oil level gauge guide attaching bolt (left hand only) and oil level gauge guide.

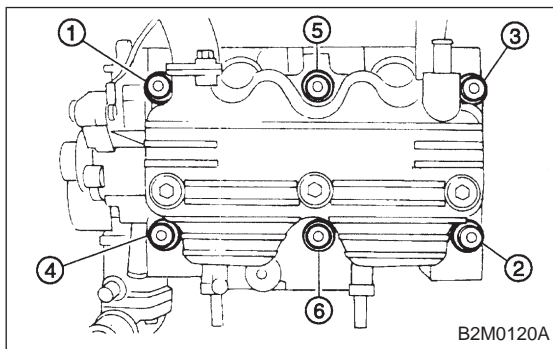

B2M0120A

3) Remove cylinder head bolts in numerical sequence shown in Figure.

**CAUTION:**

**Leave bolts ① and ③ engaged by three or four threads to prevent cylinder head from falling.**

4) While tapping cylinder head with a plastic hammer, separate it from cylinder block.

Remove bolts ① and ③ to remove cylinder head.

5) Remove cylinder head gasket.

**CAUTION:**

**Do not scratch the mating surface of cylinder head and cylinder block.**

6) Similarly, remove right side cylinder head.



## B: DISASSEMBLY

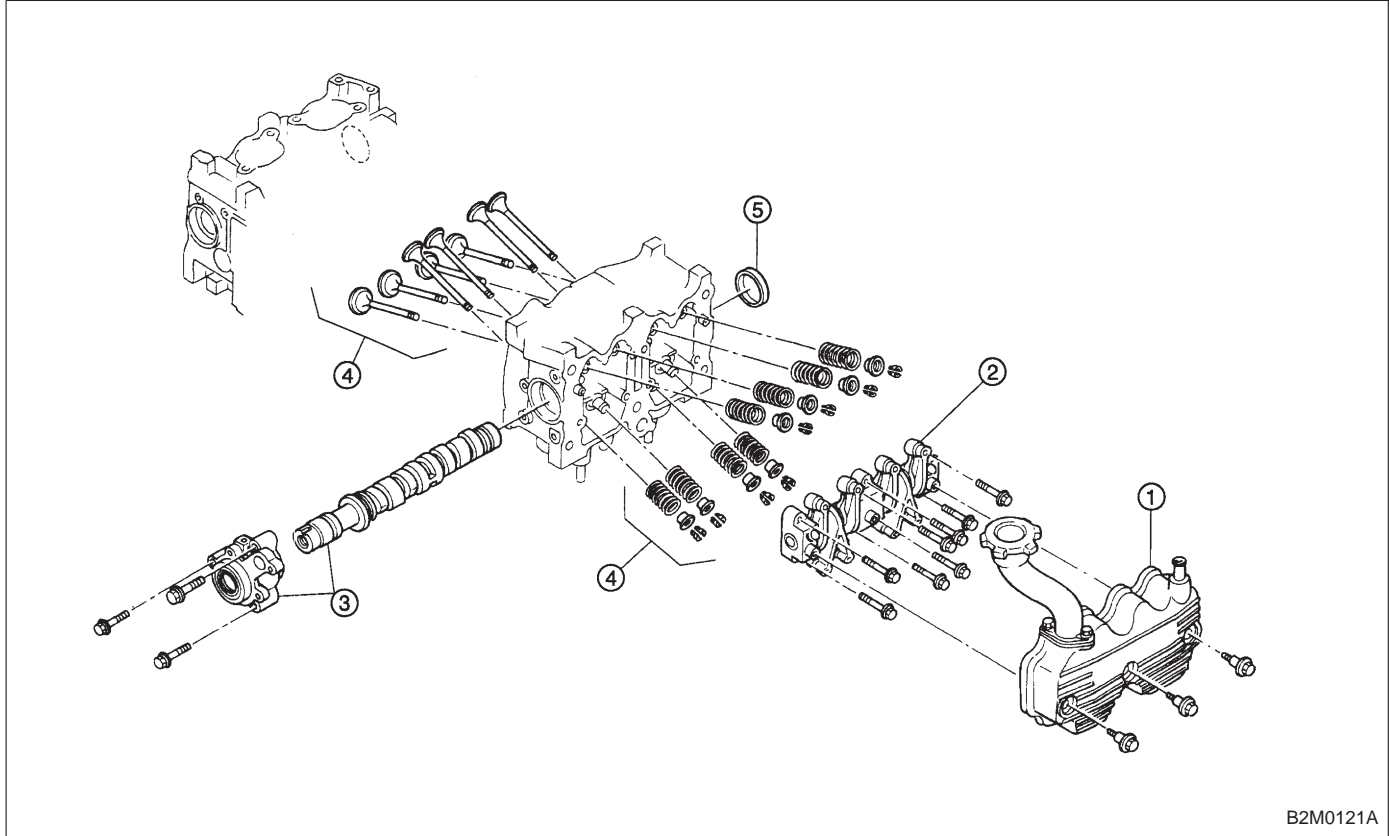

B2M0121A

- 1) Remove rocker cover.
- 2) Remove valve rocker assembly.  
<Ref. to 2-3 [W4A0].>
- 3) Remove camshaft and support.  
<Ref. to 2-3 [W5A1].>
- 4) Place cylinder head on ST.  
ST 498267200 CYLINDER HEAD TABLE

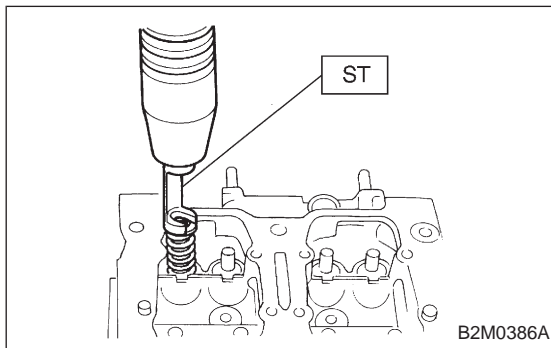

B2M0386A

- 5) Set ST on valve spring. Compress valve spring and remove the valve spring retainer key. Remove each valve and valve spring.

ST 499718000 VALVE SPRING REMOVER

**CAUTION:**

- Mark each valve to prevent confusion.
- Use extreme care not to damage the lips of the intake valve oil seals and exhaust valve oil seals.

- 6) Removal of plug (cylinder head LH)

**CAUTION:****Do not remove plug unless necessary.**

**C: INSPECTION**

**1. CYLINDER HEAD**

1) Make sure that no crack or other damage exists. In addition to visual inspection, inspect important areas by means of red lead check.

Also make sure that gasket installing surface shows no trace of gas and water leaks.

2) Place cylinder head on ST.

ST 498267200 CYLINDER HEAD TABLE

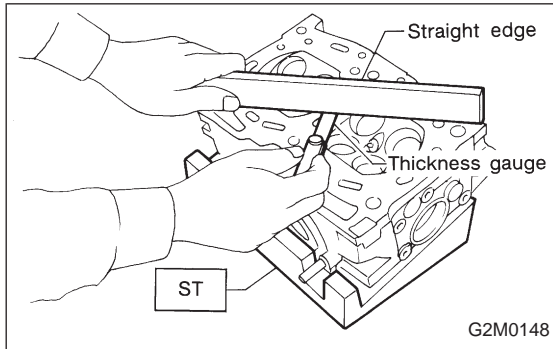

3) Measure the warping of the cylinder head surface that mates with crankcase by using a straight edge and thickness gauge.

If the warping exceeds 0.05 mm (0.0020 in), regrind the surface with a surface grinder.

**Warping limit:**

**0.05 mm (0.0020 in)**

**Grinding limit:**

**0.1 mm (0.004 in)**

**Standard height of cylinder head:**

**98.3 mm (3.870 in)**

**CAUTION:**

Uneven torque for the cylinder head bolts can cause warping. When reassembling, pay special attention to the torque so as to tighten evenly.

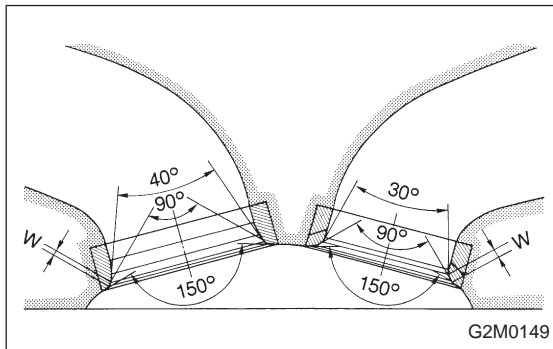

**2. VALVE SEAT**

Inspect intake and exhaust valve seats, and correct the contact surfaces with valve seat cutter if they are defective or when valve guides are replaced.

**Valve seat width: W**

**Intake**

**Standard**

**0.7 mm (0.028 in)**

**Limit**

**1.4 mm (0.055 in)**

**Exhaust**

**Standard**

**1.4 mm (0.055 in)**

**Limit**

**1.8 mm (0.071 in)**

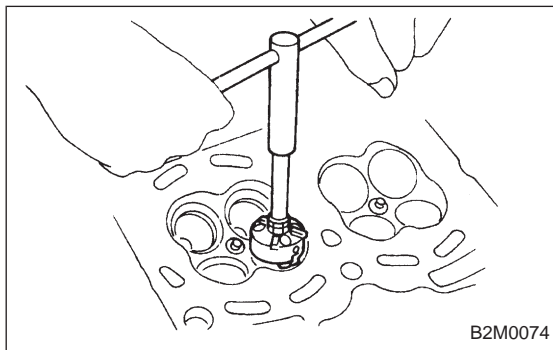

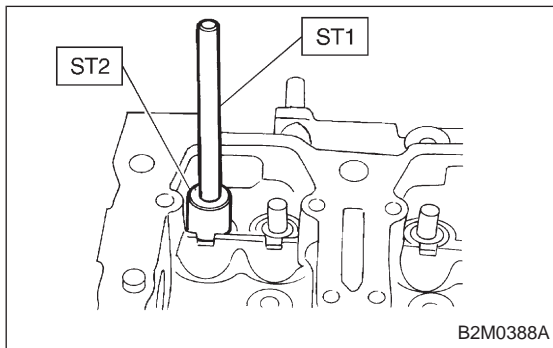
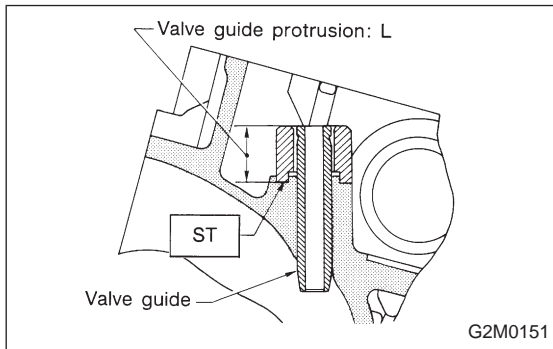
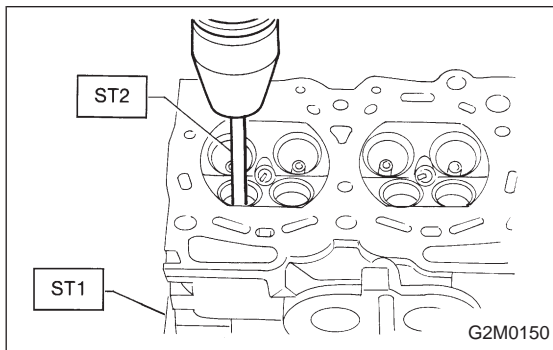
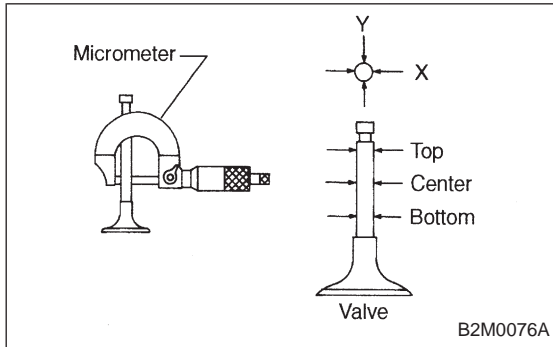
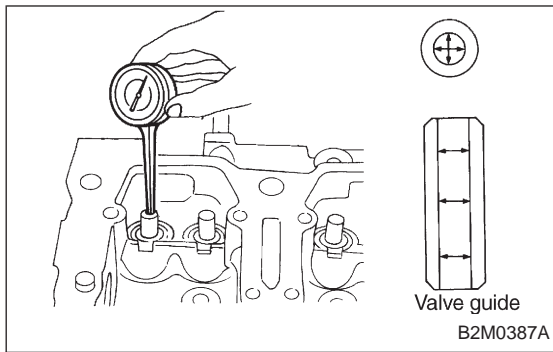

### 3. VALVE GUIDE

1) Check the clearance between valve guide and stem. The clearance can be checked by measuring the outside diameter of valve stem and the inside diameter of valve guide with outside and inside micrometers respectively.

**Clearance between the valve guide and valve stem:**

**Standard**

**Intake**

**0.035 — 0.062 mm (0.0014 — 0.0024 in)**

**Exhaust**

**0.040 — 0.067 mm (0.0016 — 0.0026 in)**

**Limit**

**0.15 mm (0.0059 in)**

**Valve guide inner diameter:**

**6.000 — 6.012 mm (0.2362 — 0.2367 in)**

**Valve stem outer diameters:**

**Intake**

**5.950 — 5.965 mm (0.2343 — 0.2348 in)**

**Exhaust**

**5.945 — 5.960 mm (0.2341 — 0.2346 in)**

2) If the clearance between valve guide and stem exceeds the specification, replace guide as follows:

(1) Place cylinder head on ST1 with the combustion chamber upward so that valve guides enter the holes in ST1.

(2) Insert ST2 into valve guide and press it down to remove valve guide.

ST1 498267200 CYLINDER HEAD TABLE

ST2 499767200 VALVE GUIDE REMOVER

(3) Turn cylinder head upside down and place ST as shown in the Figure.

ST 499767000 VALVE GUIDE ADJUSTER

(4) Before installing new oversize valve guide, make sure that neither scratches nor damages exist on the inside surface of the valve guide holes in cylinder head.

(5) Put new valve guide, coated with sufficient oil, in cylinder, and insert ST1 into valve guide. Press in until the valve guide upper end is flush with the upper surface of ST2.

ST1 499767200 VALVE GUIDE REMOVER

ST2 499767000 VALVE GUIDE ADJUSTER

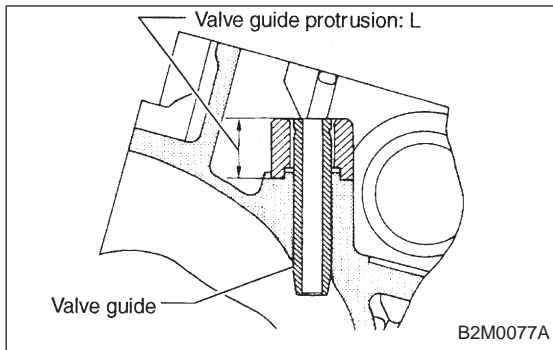

(6) Check the valve guide protrusion.

**Valve guide protrusion: L**  
**17.5 — 18.0 mm (0.689 — 0.709 in)**

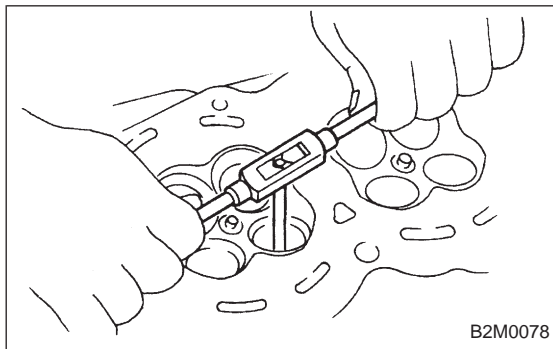

(7) Ream the inside of valve guide with ST. Gently rotate the reamer clockwise while pressing it lightly into valve guide, and return it also rotating clockwise. After reaming, clean valve guide to remove chips.

ST 499767400 VALVE GUIDE REAMER

**CAUTION:**

- Apply engine oil to the reamer when reaming.
- If the inner surface of the valve guide is torn, the edge of the reamer should be slightly ground with an oil stone.
- If the inner surface of the valve guide becomes lustrous and the reamer does not chips, use a new reamer or remedy the reamer.

(8) Recheck the contact condition between valve and valve seat after replacing valve guide.

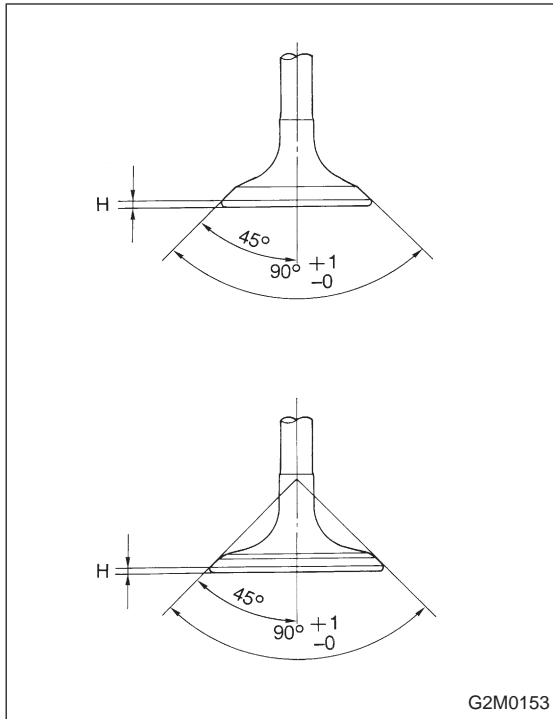

#### 4. INTAKE AND EXHAUST VALVE

1) Inspect the flange and stem of valve, and replace if damaged, worn, or deformed, or if "H" is less than the specified limit.

**H:**

**Intake**

**Standard**

**1.0 mm (0.039 in)**

**Limit**

**0.8 mm (0.031 in)**

**Exhaust**

**Standard**

**1.2 mm (0.047 in)**

**Limit**

**0.8 mm (0.031 in)**

**Valve overall length:**

**Intake**

**101.0 mm (3.976 in)**

**Exhaust**

**101.2 mm (3.984 in)**

2) Put a small amount of grinding compound on the seat surface and lap the valve and seat surface. Also refer to 2. VALVE SEAT [W6C2] at this time. Install a new intake valve oil seal after lapping.

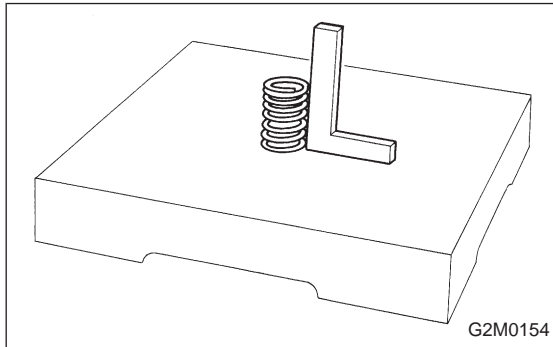

#### 5. VALVE SPRINGS

1) Check valve springs for damage, free length, and tension. Replace valve spring if it is not to the specifications presented below.

2) To measure the squareness of the valve spring, stand the spring on a surface plate and measure its deflection at the top using a try square.

Free length	44.05 mm (1.7342 in)
Squareness	2.5°, 1.9 mm (0.075 in)
Tension/spring height	174.6 — 200.1 N (17.8 — 20.4 kg, 39.2 — 45.0 lb)/ 36.0 mm (1.417 in)
	405.0 — 458.0 N (41.3 — 46.7 kg, 91.1 — 103.0 lb)/ 28.2 mm (1.110 in)

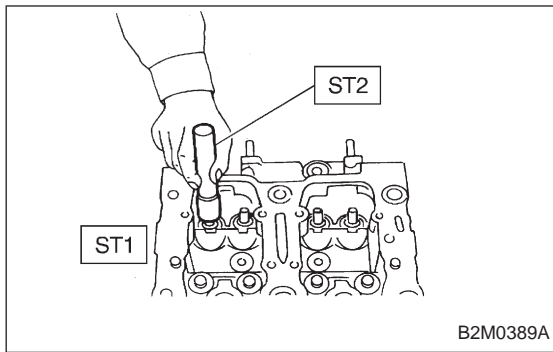

## 6. INTAKE AND EXHAUST VALVE OIL SEAL

Replace oil seal with new one, if lip is damaged or spring out of place, or when the surfaces of intake valve and valve seat are reconditioned or intake valve guide is replaced.

- 1) Place cylinder head on ST1.
- 2) Press-fit oil seal to the specified dimension indicated in the Figure by using ST2.

ST1 498267200 CYLINDER HEAD TABLE

ST2 498857100 VALVE OIL SEAL GUIDE

### CAUTION:

- Apply engine oil to oil seal before press-fitting.
- When press-fitting oil seal, do not use hammer or strike in.
- Differentiate between intake valve oil seal and exhaust valve oil seal by noting their difference in color.

#### *Color of rubber part:*

*Intake [Black]*

*Exhaust [Brown]*

#### *Color of spring part:*

*Intake [White]*

*Exhaust [White]*

## D: ASSEMBLY

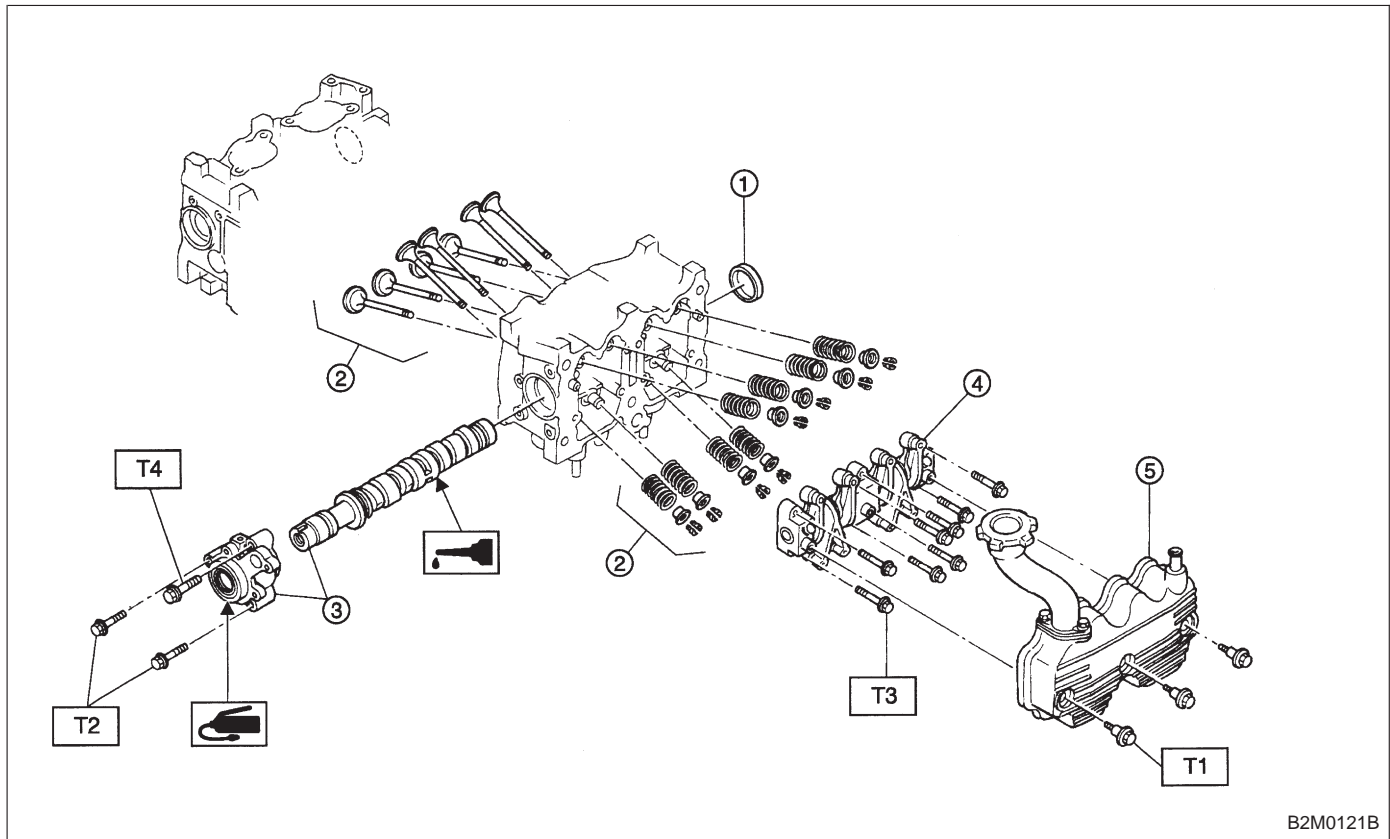

B2M0121B

**Tightening torque: N·m (kg·m, ft·lb)**

T1: 5±1 (0.5±0.1, 3.6±0.7)

T2: 10 (1.0, 7)

T3: 12±1 (1.2±0.1, 8.7±0.7)

T4: 16 (1.6, 12)

1) Install plug (cylinder head LH) by using ST.

ST 499587100 OIL SEAL INSTALLER

2) Installation of valve spring and valve

(1) Place cylinder head on ST.

ST 498267200 CYLINDER HEAD TABLE

(2) Coat stem of each valve with engine oil and insert valve into valve guide.

**CAUTION:**

**When inserting valve into valve guide, use special care not to damage the oil seal lip.**

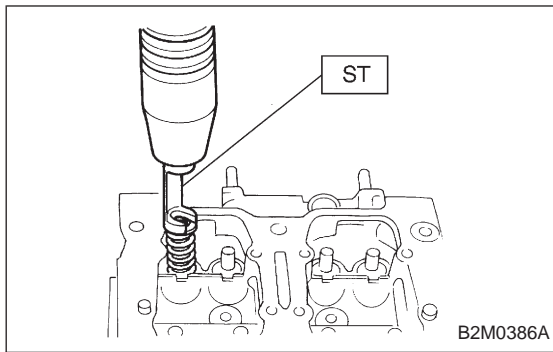

(3) Install valve spring and retainer.

**CAUTION:**

**Be sure to install the valve springs with their close-coiled end facing the seat on the cylinder head.**

(4) Set ST on valve spring.

ST 499718000 VALVE SPRING REMOVER

(5) Compress valve spring and fit valve spring retainer key.

(6) After installing, tap valve spring retainers lightly with wooden hammer for better seating.

3) Install camshaft and support.

<Ref. to 2-3 [W5C1].>

4) Install valve rocker assembly.

<Ref. to 2-3 [W4E0].>

5) Install rocker cover.

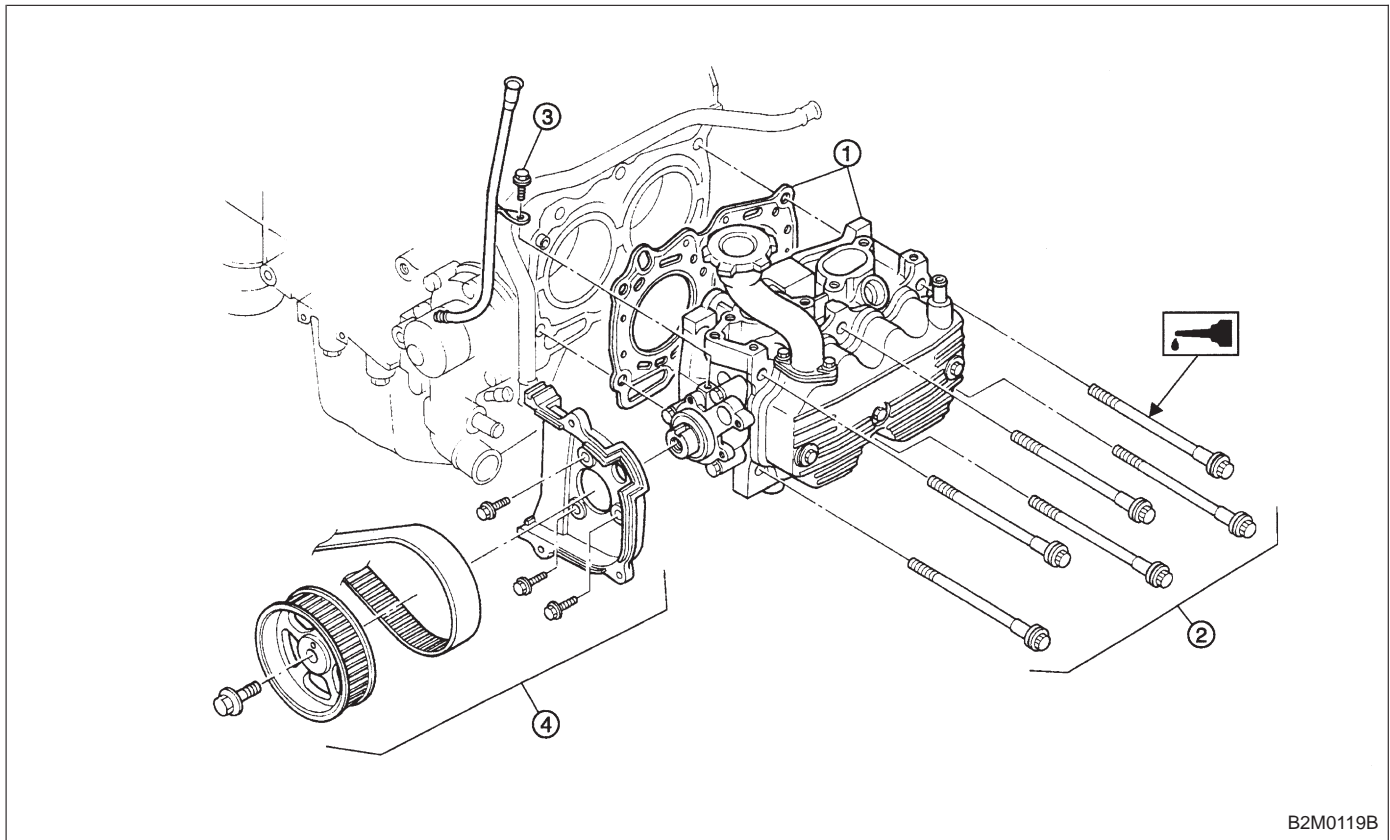

**E: INSTALLATION****1. CYLINDER HEAD**

B2M0119B

1) Install cylinder head and gaskets on cylinder block.

**CAUTION:**

**Use new cylinder head gaskets.**

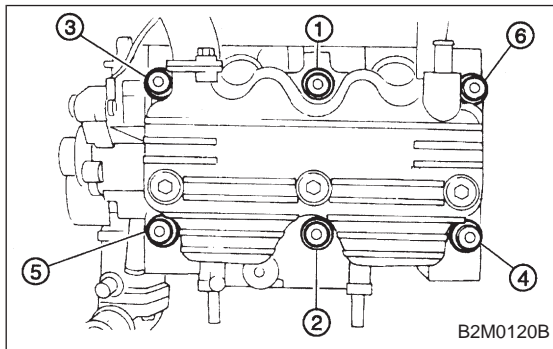

B2M0120B

2) Tighten cylinder head bolts.

(1) Apply a coat of engine oil to washers and bolt threads.

(2) Tighten all bolts to 29 N·m (3.0 kg-m, 22 ft-lb) in numerical sequence.

Then tighten all bolts to 69 N·m (7.0 kg-m, 51 ft-lb) in numerical sequence.

(3) Back off all bolts by 180° first; back them off by 180° again.

(4) Tighten bolts ① and ② to 34 N·m (3.5 kg-m, 25 ft-lb).

(5) Tighten bolts ③, ④, ⑤ and ⑥ to 15 N·m (1.5 kg-m, 11 ft-lb).

(6) Tighten all bolts by 80 to 90° in numerical sequence.

**CAUTION:**

**Do not tighten bolts more than 90°.**

(7) Further tighten all bolts by 80 to 90° in numerical sequence.

**CAUTION:**

**Ensure that the total “re-tightening angle” [steps (6) and (7) above] do not exceed 180°.**

3) Install oil level gauge guide attaching bolt (left side only).

4) Install timing belt, camshaft sprocket and related parts. <Ref. to 2-3 [W3C1].>

## 2. INTAKE MANIFOLD

**CAUTION:**

**Use dry compressed air to remove foreign particles before installing each solenoid valve and sensor.**

1) Install engine coolant pipe.

2) Install intake manifold. <Ref. to 2-7 [W4D0].>

3) Remove ENGINE STAND (ST).

## 7. Cylinder Block

### A: REMOVAL

#### 1. RELATED PARTS

1) Remove timing belt, camshaft sprocket and related parts.

<Ref. to 2-3 [W3A1].>

2) Remove intake manifold and cylinder head.

<Ref. to 2-3 [W6A0].>

#### 2. OIL PUMP AND ENGINE COOLANT PUMP

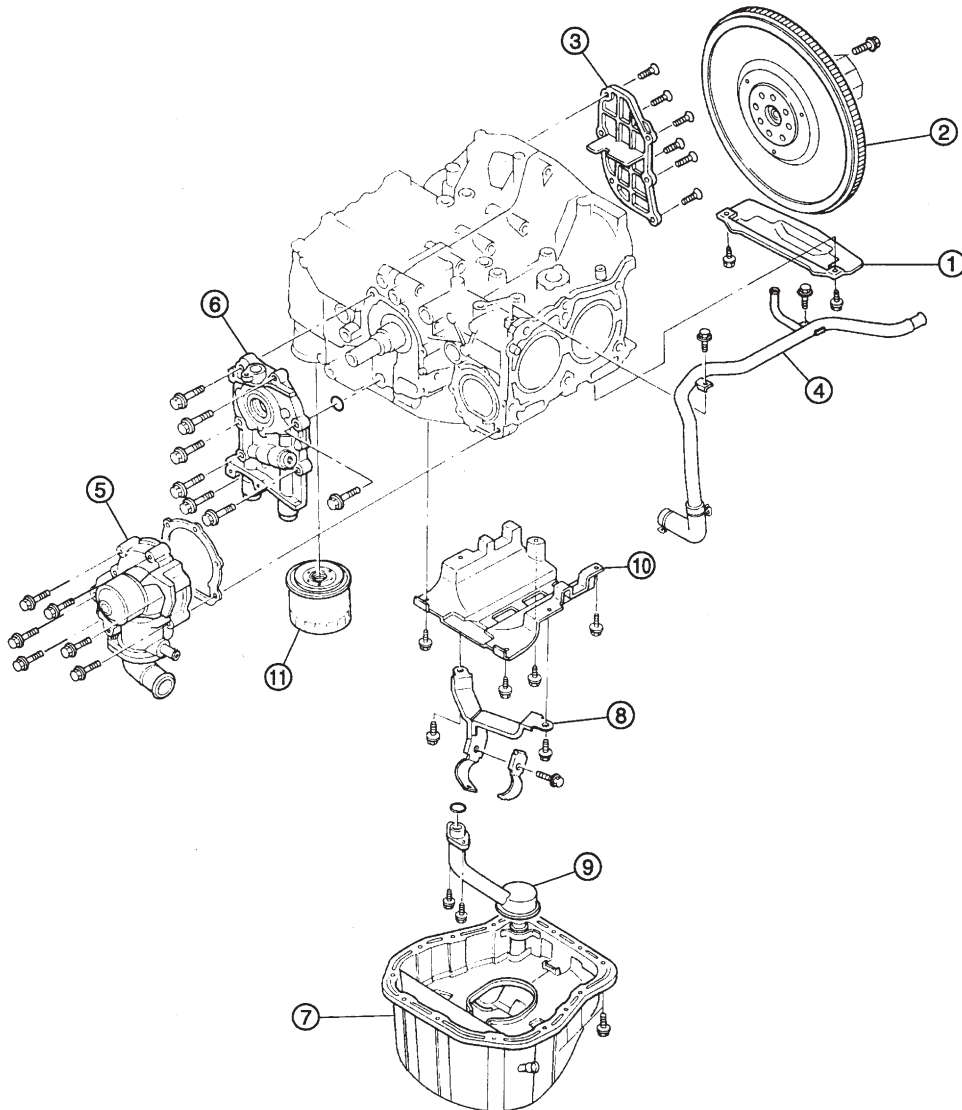

B2M0124A

1) Remove housing cover.

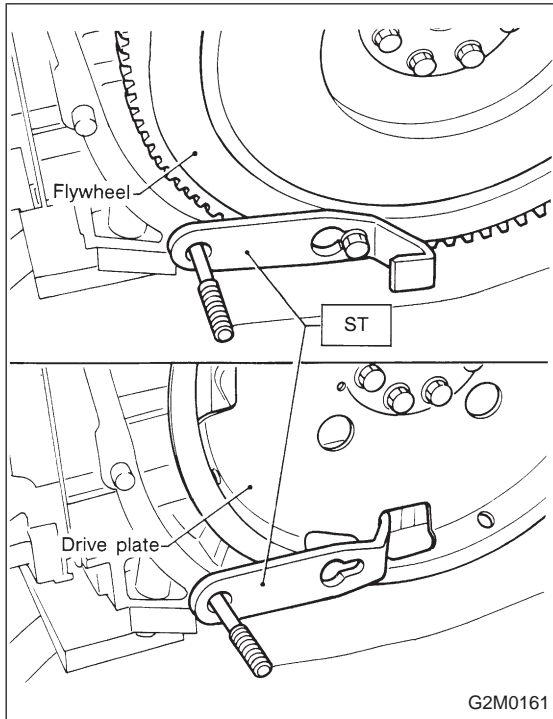

2) Remove flywheel or drive plate.  
To lock crankshaft use ST.

ST 498497100 CRANKSHAFT STOPPER

3) Remove oil separator cover.

4) Remove engine coolant pipe.

5) Remove engine coolant pump.

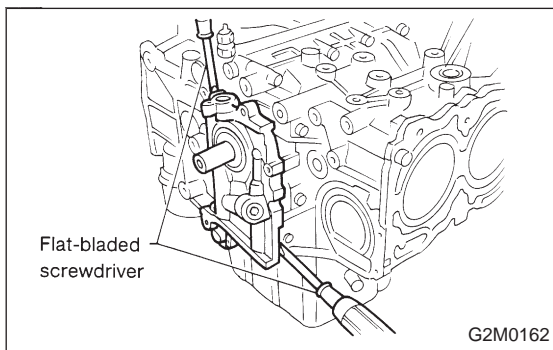

6) Remove oil pump from cylinder block.

Use a flat-bladed screwdriver as shown in Figure when removing oil pump.

**CAUTION:**

**Be careful not to scratch the mating surface of cylinder block and oil pump.**

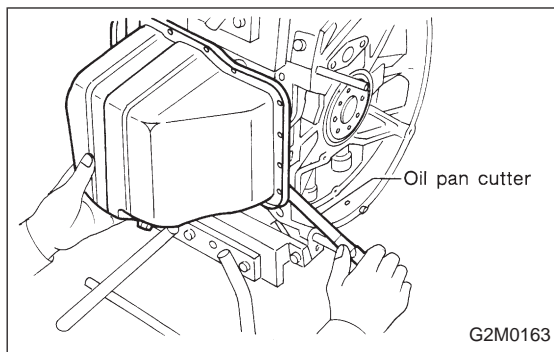

## 7) Removal of oil pan

- (1) Turn cylinder block with #2 and #4 piston sides facing upward.
- (2) Remove bolts which secure oil pan to cylinder block.
- (3) Insert a oil pan cutter blade between cylinder block-to-oil pan clearance and remove oil pan.

**CAUTION:**

**Do not use a screwdriver or similar tool in place of oil-pan cutter.**

8) Remove oil strainer stay.

9) Remove oil strainer.

10) Remove baffle plate.

11) Remove oil filter.

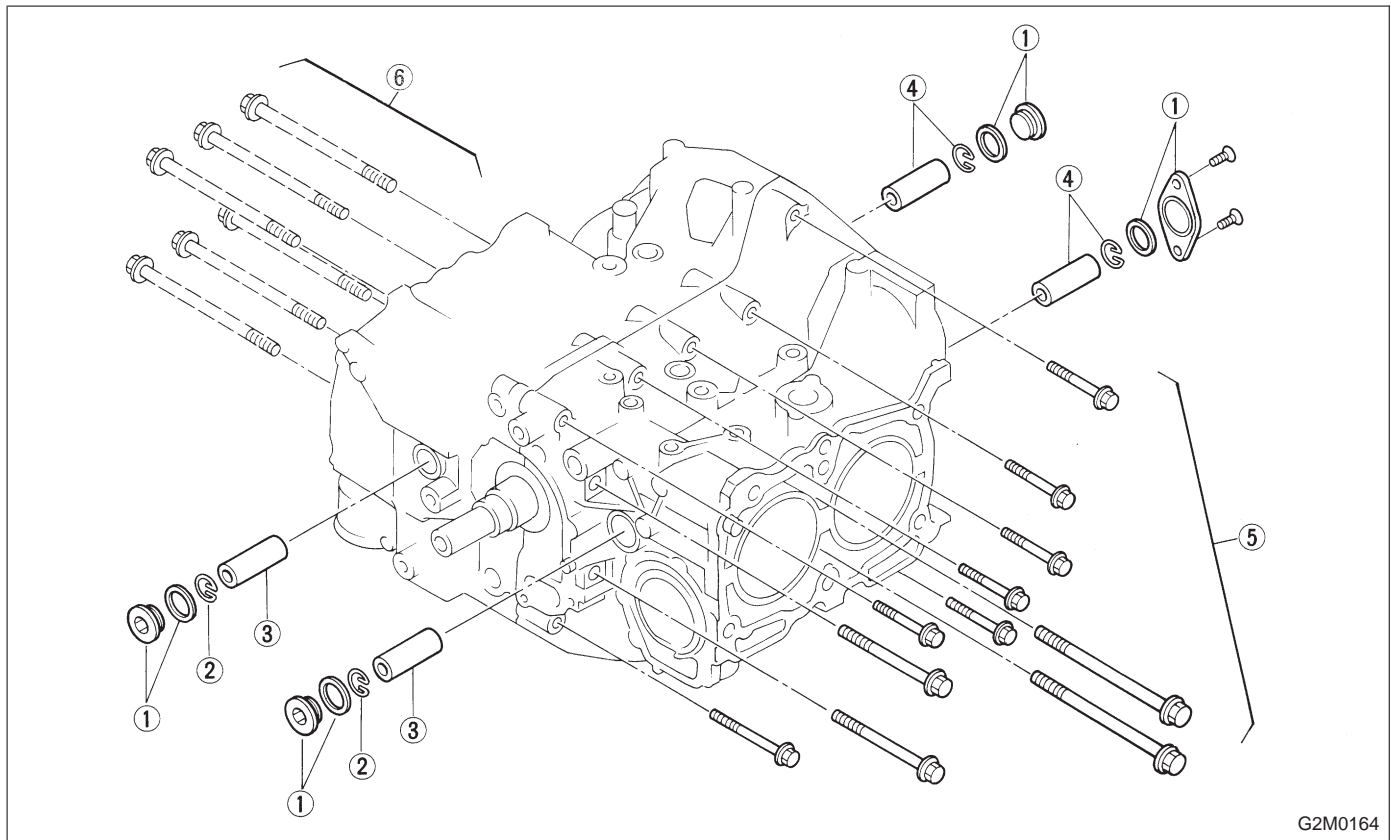
**B: DISASSEMBLY****1. PISTON PIN AND CYLINDER BLOCK CONNECTING BOLT**

- 1) Remove service hole cover and service hole plugs using hexagon wrench (14 mm).

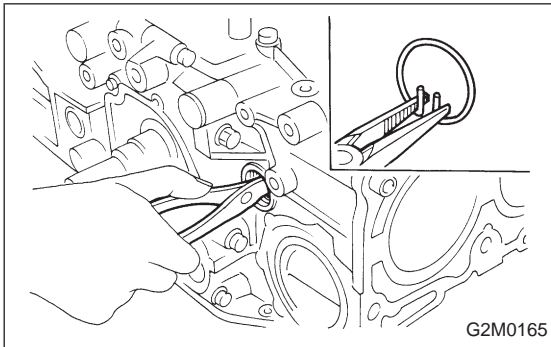

- 2) Rotate crankshaft to bring #1 and #2 pistons to bottom dead center position, then remove piston circlip through service hole of #1 and #2 cylinders.

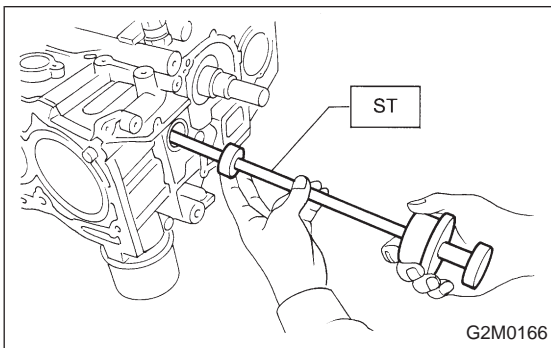

- 3) Draw out piston pin from #1 and #2 pistons by using ST.  
ST 499097500 PISTON PIN REMOVER

**CAUTION:**  
Be careful not to confuse original combination of piston, piston pin and cylinder.

- 4) Similarly remove piston pins from #3 and #4 pistons by using ST.

- 5) Remove bolts which connect cylinder block on the side of #2 and #4 cylinders.
- 6) Back off bolts which connect cylinder block on the side of #1 and #3 cylinders two or three turns.

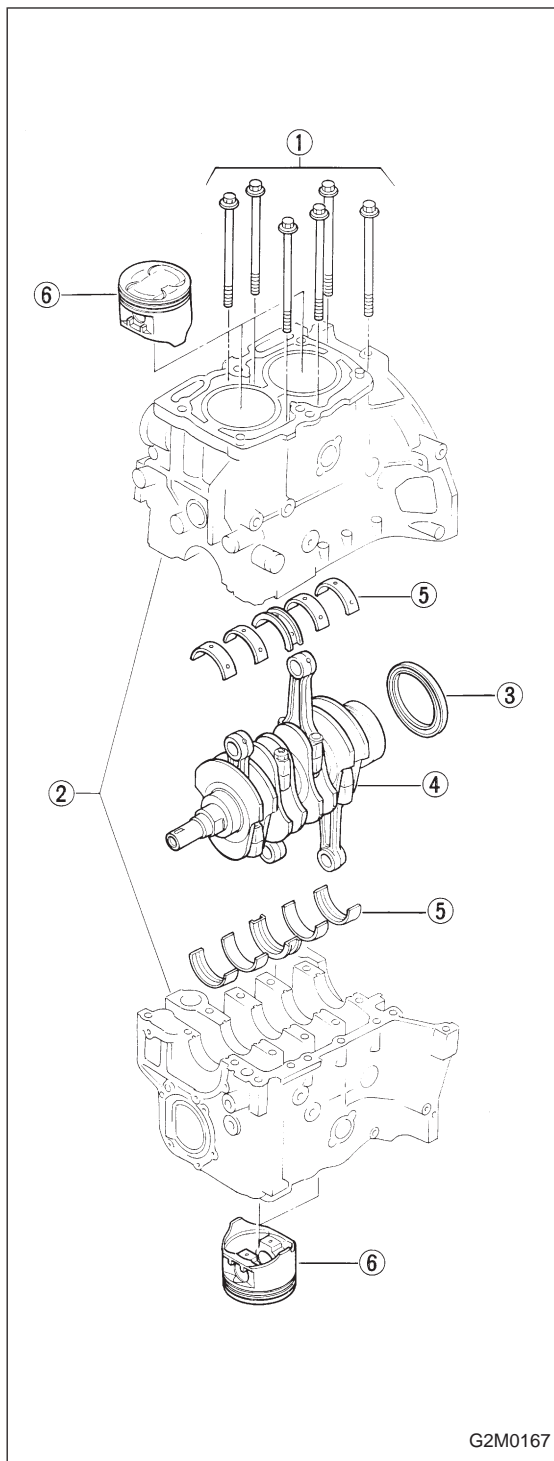

G2M0167

## 2. CYLINDER BLOCK

1) Set up cylinder block so that #1 and #3 cylinders are on the upper side, then remove cylinder block connecting bolts.

2) Separate left-hand and right-hand cylinder blocks.

### CAUTION:

**When separating cylinder block, do not allow the connecting rod to fall and damage the cylinder block.**

3) Remove rear oil seal.

4) Remove crankshaft together with connecting rod.

5) Remove crankshaft bearings from cylinder block using hammer handle.

### CAUTION:

**Do not confuse combination of crankshaft bearings. Press bearing at the end opposite to locking lip.**

6) Draw out each piston from cylinder block using wooden bar or hammer handle.

### CAUTION:

**Do not confuse combination of piston and cylinder.**

## 3. CRANKSHAFT AND PISTON

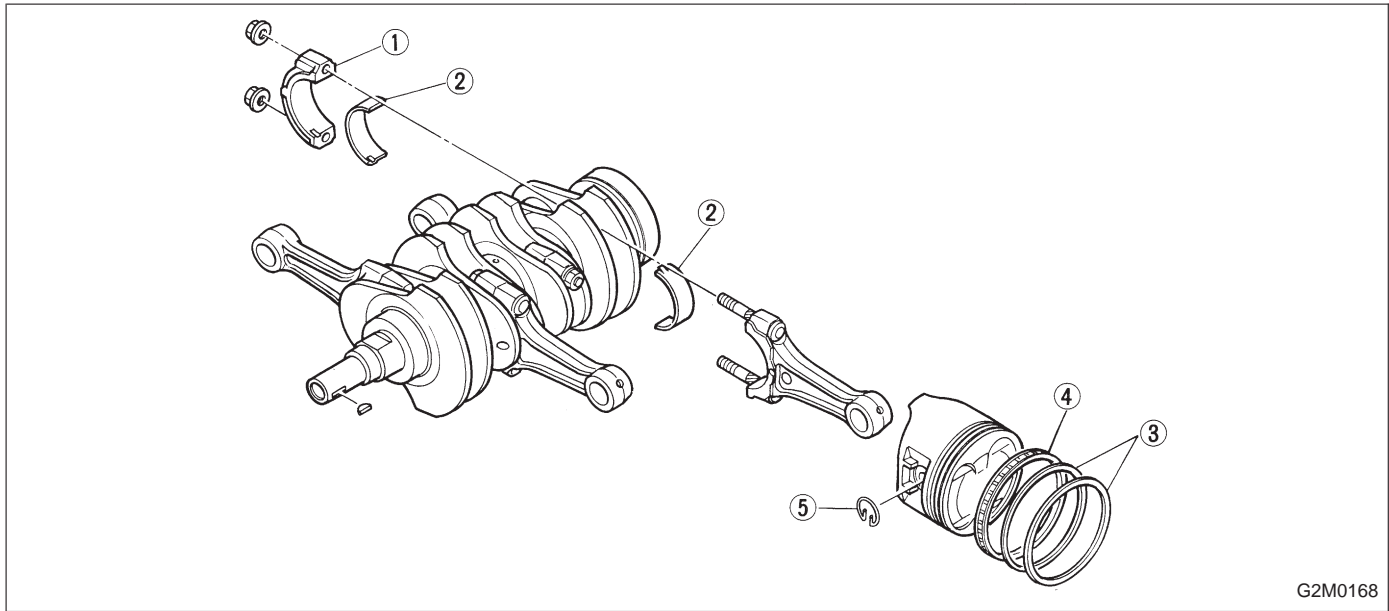

- 1) Remove connecting rod cap.
- 2) Remove connecting rod bearing.

**CAUTION:**

**Arrange removed connecting rod, connecting rod cap and bearing in order to prevent confusion.**

- 3) Remove piston rings using the piston ring expander.
- 4) Remove the oil ring by hand.

**CAUTION:**

**Arrange the removed piston rings in good order to prevent confusion.**

- 5) Remove circlip.



**C: INSPECTION****1. CYLINDER BLOCK**

- 1) Check for cracks and damage visually. Especially, inspect important parts by means of red lead check.
- 2) Check the oil passages for clogging.
- 3) Inspect crankcase surface that mates with cylinder head for warping by using a straight edge, and correct by grinding if necessary.

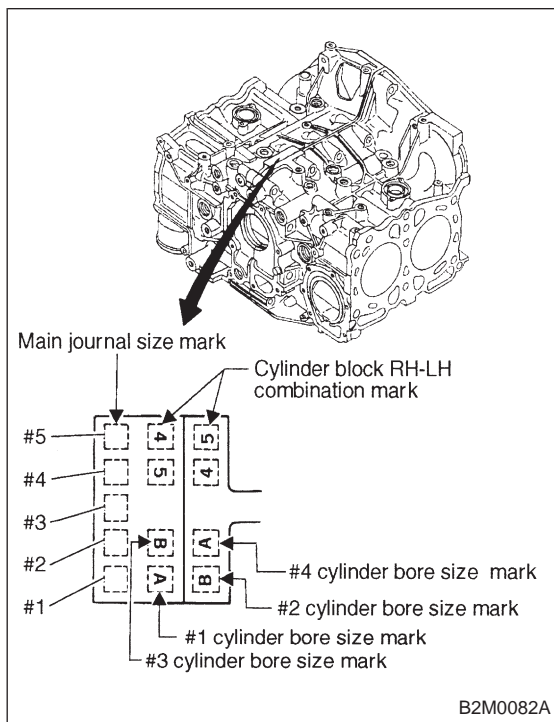
**Warping limit:****0.05 mm (0.0020 in)****Grinding limit:****0.1 mm (0.004 in)****Standard height of cylinder block:****201.0 mm (7.91 in)****2. CYLINDER AND PISTON**

- 1) The cylinder bore size is stamped on the cylinder block's front upper surface.

**NOTE:**

Standard sized pistons are classified into two grades, "A" and "B". These grades should be used as a guide line in selecting a standard piston.

**Standard diameter:****A: 96.905 — 96.915 mm (3.8151 — 3.8155 in)****B: 96.895 — 96.905 mm (3.8148 — 3.8151 in)**

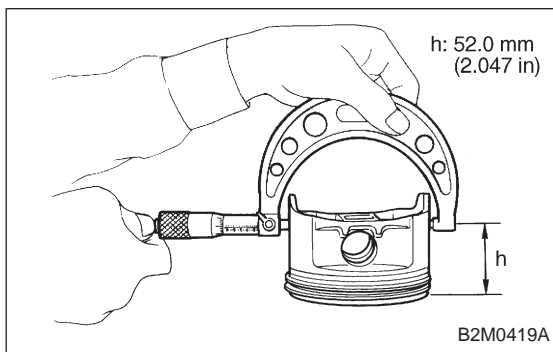
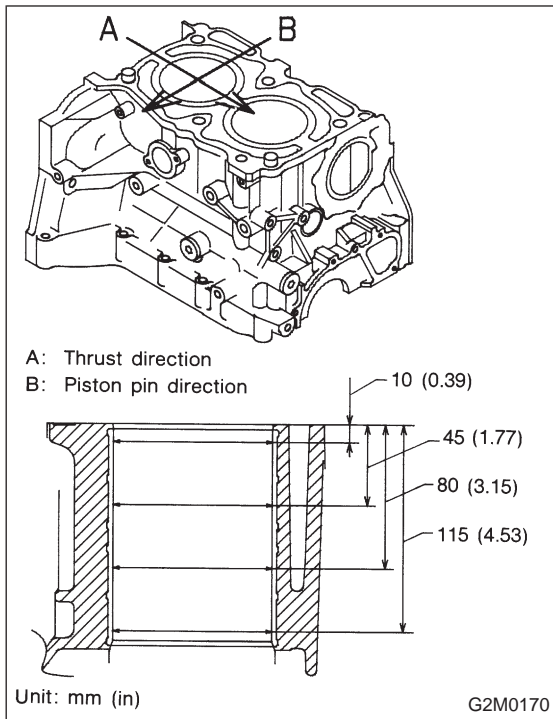

2) How to measure the inner diameter of each cylinder  
Measure the inner diameter of each cylinder in both the thrust and piston pin directions at the heights shown in the Figure, using a cylinder bore gauge.

**CAUTION:**

Measurement should be performed at a temperature 20°C (68°F).

**Taper:**

**Standard**

0.015 mm (0.0006 in)

**Limit**

0.050 mm (0.0020 in)

**Out-of-roundness:**

**Standard**

0.010 mm (0.0004 in)

**Limit**

0.050 mm (0.0020 in)

3) When piston is to be replaced due to general or cylinder wear, determine a suitable sized piston by measuring the piston clearance.

4) How to measure the outer diameter of each piston  
Measure the outer diameter of each piston at the height shown in the Figure. (Thrust direction)

**CAUTION:**

Measurement should be performed at a temperature of 20°C (68°F).

**Piston outer diameter:**

**Standard**

A: 96.885 — 96.895 mm (3.8144 — 3.8148 in)

B: 96.875 — 96.885 mm (3.8140 — 3.8144 in)

0.25 mm (0.0098 in) oversize

97.115 — 97.145 mm (3.8234 — 3.8246 in)

0.50 mm (0.0197 in) oversize

97.365 — 97.395 mm (3.8333 — 3.8344 in)

5) Calculate the clearance between cylinder and piston.

**CAUTION:**

Measurement should be performed at a temperature of 20°C (68°F).

**Cylinder to piston clearance at 20°C (68°F):**

**Standard**

0.010 — 0.030 mm (0.0004 — 0.0012 in)

**Limit**

0.050 mm (0.0020 in)

## 6) Boring and honing

- (1) If the value of taper, out-of-roundness, or cylinder-to-piston clearance measured exceeds the specified limit or if there is any damage on the cylinder wall, rebore it to use an oversize piston.

**CAUTION:**

**When any of the cylinders needs reboring, all other cylinders must be bored at the same time, and use oversize pistons. Do not perform boring on one cylinder only, nor use an oversize piston for one cylinder only.**

- (2) If the cylinder inner diameter exceeds the limit after boring and honing, replace the crankcase.

**CAUTION:**

**Immediately after reboring, the cylinder diameter may differ from its real diameter due to temperature rise. Thus, pay attention to this when measuring the cylinder diameter.**

**Limit of cylinder enlarging (boring):**

**0.5 mm (0.020 in)**

**3. PISTON AND PISTON PIN**

- 1) Check pistons and piston pins for damage, cracks, and wear and the piston ring grooves for wear and damage. Replace if defective.

- 2) Measure the piston-to-cylinder clearance at each cylinder as instructed in 2. CYLINDER AND PISTON [W7C2]. If any of the clearances is not to specification, replace the piston or bore the cylinder to use an oversize piston.

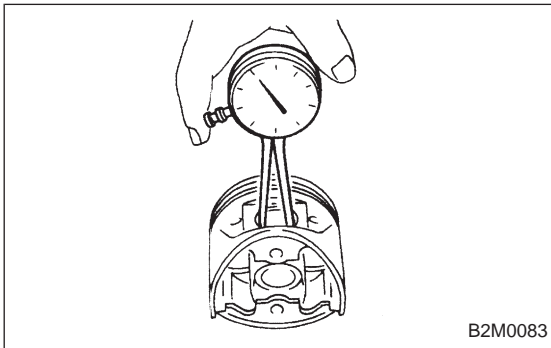

B2M0083

- 3) Make sure that piston pin can be inserted into the piston pin hole with a thumb at 20°C (68°F). Replace if defective.

**Standard clearance between piston pin and hole in piston:****Standard**

**0.004 — 0.010 mm (0.0002 — 0.0004 in)**

**Limit**

**0.020 mm (0.0008 in)**

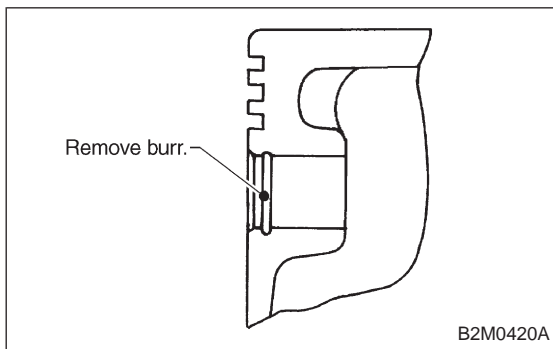
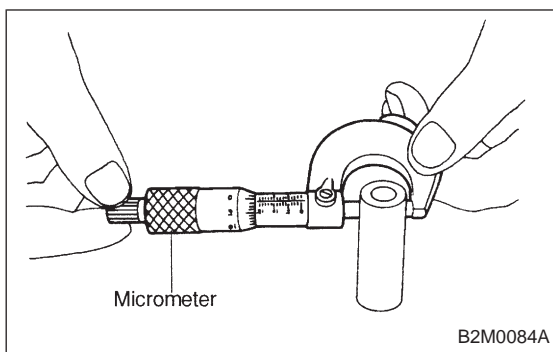

- 4) Check circlip installation groove on the piston for burr. If necessary, remove burr from the groove so that piston pin can lightly move.
- 5) Check piston pin circlip for distortion, cracks and wear.

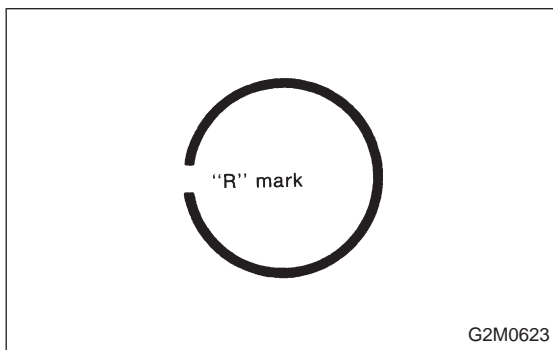

**4. PISTON RING**

- 1) If piston ring is broken, damaged, or worn, or if its tension is insufficient, or when the piston is replaced, replace piston ring with a new one of the same size as the piston.

**CAUTION:**

- "R" is marked on the end of the top and second rings. When installing the rings to the piston, face this mark upward.

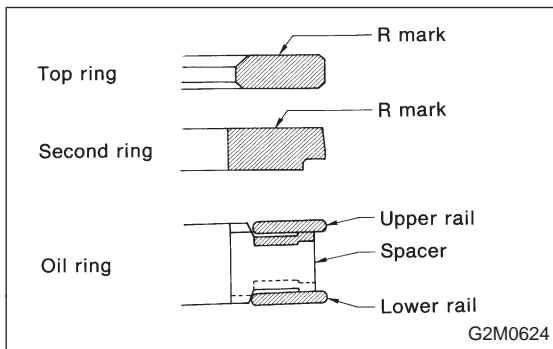

- The oil ring is a combined ring consisting of two rails and a spacer in between. When installing, be careful to assemble correctly.

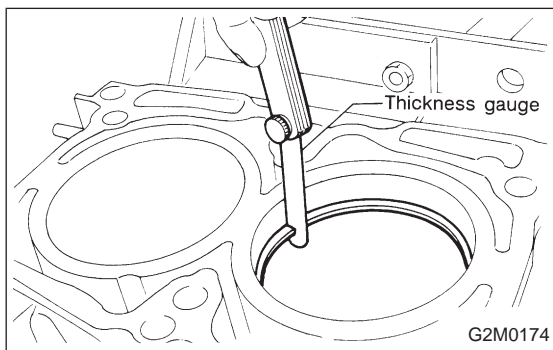

- 2) Squarely place piston ring and oil ring in cylinder, and measure the piston ring gap with a thickness gauge.

Unit: mm (in)

		Standard	Limit
Piston ring gap	Top ring	0.20 — 0.35 (0.0079 — 0.0138)	1.0 (0.039)
	Second ring	0.20 — 0.50 (0.0079 — 0.0197)	1.0 (0.039)
	Oil ring rail	0.20 — 0.70 (0.0079 — 0.0276)	1.5 (0.059)

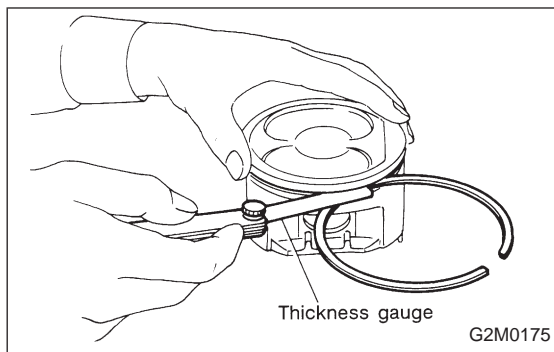

3) Measure the clearance between piston ring and piston ring groove with a thickness gauge.

**CAUTION:**

**Before measuring the clearance, clean the piston ring groove and piston ring.**

Unit: mm (in)

		Standard	Limit
Clearance between piston ring and piston ring groove	Top ring	0.040 — 0.080 (0.0016 — 0.0031)	0.15 (0.0059)
	Second ring	0.030 — 0.070 (0.0012 — 0.0028)	0.15 (0.0059)

## 5. CONNECTING ROD

1) Replace connecting rod, if the large or small end thrust surface is damaged.

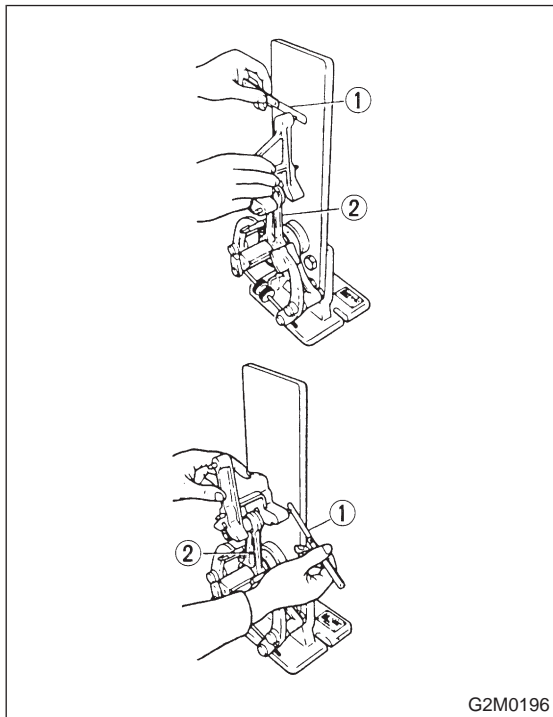

2) Check for bend or twist using a connecting rod aligner. Replace connecting rod if the bend or twist exceeds the limit.

**Limit of bend or twist per 100 mm (3.94 in) in length:  
0.10 mm (0.0039 in)**

- ① Thickness gauge
- ② Connecting rod

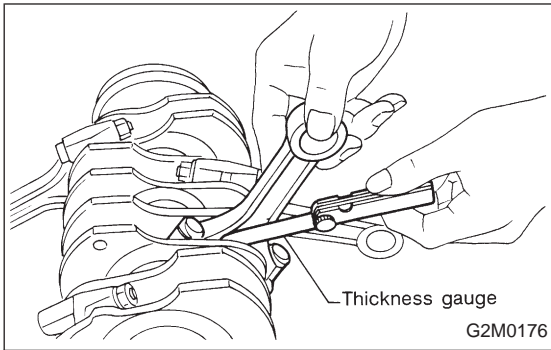

3) Install connecting rod fitted with bearing to crankshaft and measure the side clearance (thrust clearance). Replace connecting rod if the side clearance exceeds the specified limit.

**Connecting rod side clearance:**

**Standard**

**0.070 — 0.330 mm (0.0028 — 0.0130 in)**

**Limit**

**0.4 mm (0.016 in)**

4) Inspect connecting rod bearing for scar, peeling, seizure, melting, wear, etc.

5) Measure the oil clearance on individual connecting rod bearings by means of plastigauge. If any oil clearance is not within specification, replace the defective bearing with a new one of standard size or undersize as necessary. (See the table below.)

**Connecting rod oil clearance:**

**Standard**

**0.015 — 0.045 mm (0.0006 — 0.0018 in)**

**Limit**

**0.05 mm (0.0020 in)**

Unit: mm (in)

Bearing	Bearing size (Thickness at center)	Outer diameter of crank pin
Standard	1.492 — 1.501 (0.0587 — 0.0591)	51.984 — 52.000 (2.0466 — 2.0472)
0.03 (0.0012) undersize	1.510 — 1.513 (0.0594 — 0.0596)	51.954 — 51.970 (2.0454 — 2.0461)
0.05 (0.0020) undersize	1.520 — 1.523 (0.0598 — 0.0600)	51.934 — 51.950 (2.0446 — 2.0453)
0.25 (0.0098) undersize	1.620 — 1.623 (0.0638 — 0.0639)	51.734 — 51.750 (2.0368 — 2.0374)

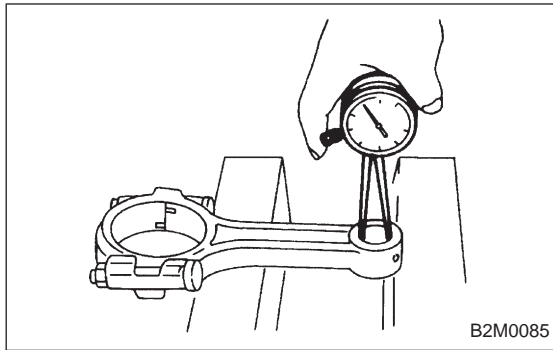

6) Inspect bushing at connecting rod small end, and replace if worn or damaged. Also measure the piston pin clearance at the connecting rod small end.

**Clearance between piston pin and bushing:**

**Standard**

0 — 0.022 mm (0 — 0.0009 in)

**Limit**

0.030 mm (0.0012 in)

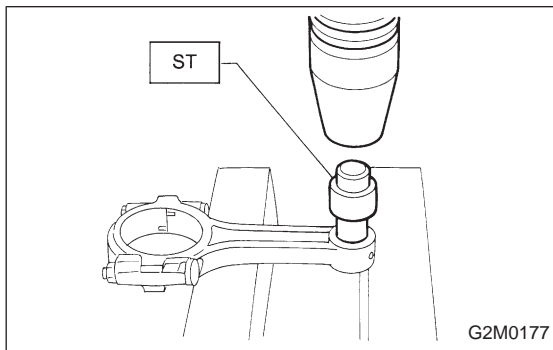
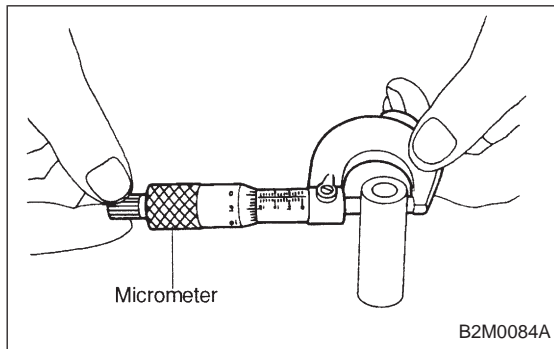

7) Replacement procedure is as follows.

(1) Remove bushing from connecting rod with ST and press.

(2) Press bushing with ST after applying oil on the periphery of bushing.

ST 499037100 CONNECTING ROD BUSHING  
REMOVER AND INSTALLER

(3) Make two 3 mm (0.12 in) holes in bushing. Ream the inside of bushing.

(4) After completion of reaming, clean bushing to remove chips.

## 6. CRANKSHAFT AND CRANKSHAFT BEARING

1) Clean crankshaft completely and check for cracks by means of red lead check etc., and replace if defective.

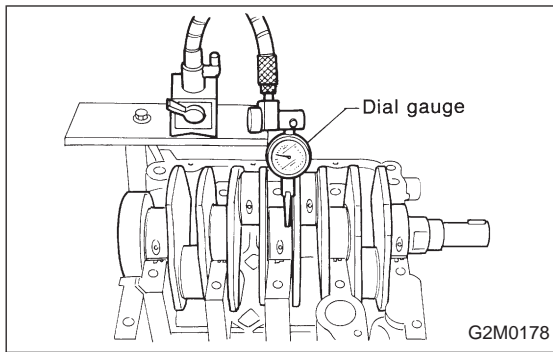

2) Measure the crankshaft bend, and correct or replace if it exceeds the limit.

**CAUTION:**

**If a suitable V-block is not available, install #1 and #5 crankshaft bearing on cylinder block, position crankshaft on these bearings and measure crankshaft bend using a dial gauge.**

**Crankshaft bend limit:  
0.035 mm (0.0014 in)**

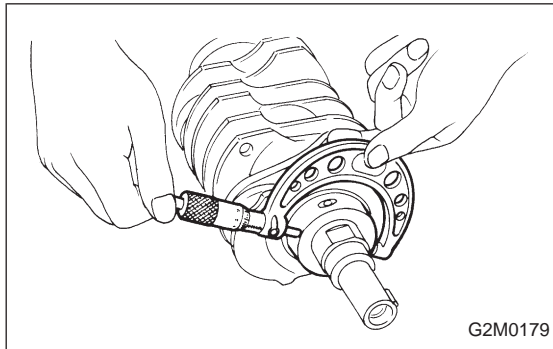

3) Inspect the crank journal and crank pin for wear. If not to specifications, replace bearing with an undersize one, and replace or recondition crankshaft as necessary. When grinding crank journal or crank pin, finish them to the specified dimensions according to the undersize bearing to be used.

**Crank pin and crank journal:  
Out-of-roundness  
0.030 mm (0.0012 in) or less  
Taper limit  
0.07 mm (0.0028 in)  
Grinding limit  
0.25 mm (0.0098 in)**

Unit: mm (in)

		Crank journal diameter		Crank pin diameter
		#1, #5	#2, #3, #4	
Standard	Journal O.D.	59.992 — 60.008 (2.3619 — 2.3625)	59.992 — 60.008 (2.3619 — 2.3625)	51.984 — 52.000 (2.0466 — 2.0472)
	Bearing size (Thickness at center)	1.998 — 2.011 (0.0787 — 0.0792)	2.000 — 2.013 (0.0787 — 0.0793)	1.492 — 1.501 (0.0587 — 0.0591)
0.03 (0.0012) undersize	Journal O.D.	59.962 — 59.978 (2.3607 — 2.3613)	59.954 — 59.970 (2.3604 — 2.3610)	51.954 — 51.970 (2.0454 — 2.0461)
	Bearing size (Thickness at center)	2.017 — 2.020 (0.0794 — 0.0795)	2.019 — 2.022 (0.0795 — 0.0796)	1.510 — 1.513 (0.0594 — 0.0596)
0.05 (0.0020) undersize	Journal O.D.	59.934 — 59.950 (2.3596 — 2.3602)	59.934 — 59.950 (2.3596 — 2.3602)	51.934 — 51.950 (2.0446 — 2.0453)
	Bearing size (Thickness at center)	2.027 — 2.030 (0.0798 — 0.0799)	2.029 — 2.032 (0.0799 — 0.0800)	1.520 — 1.523 (0.0598 — 0.0600)
0.25 (0.0098) undersize	Journal O.D.	59.742 — 59.758 (2.3520 — 2.3527)	59.734 — 59.750 (2.3517 — 2.3524)	51.734 — 51.750 (2.0368 — 2.0374)
	Bearing size (Thickness at center)	2.127 — 2.130 (0.0837 — 0.0839)	2.129 — 2.132 (0.0838 — 0.0839)	1.620 — 1.623 (0.0638 — 0.0639)

O.D. ... Outer Diameter



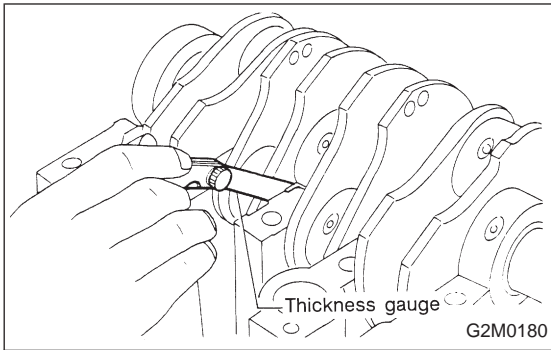

4) Measure the thrust clearance of crankshaft at center bearing. If the clearance exceeds the limit, replace bearing.

**Crankshaft thrust clearance:**

**Standard**

**0.030 — 0.115 mm (0.0012 — 0.0045 in)**

**Limit**

**0.25 mm (0.0098 in)**

5) Inspect individual crankshaft bearings for signs of flaking, seizure, melting, and wear.

6) Measure the oil clearance on each crankshaft bearing by means of plastigauge. If the measurement is not within the specification, replace defective bearing with an under-size one, and replace or recondition crankshaft as necessary.

Unit: mm (in)

Crankshaft oil clearance		
Standard	#1, #5	0.003 — 0.030 (0.0001 — 0.0012)
	#2, #3, #4	0.010 — 0.033 (0.0004 — 0.0013)
Limit	#1, #3, #5	0.040 (0.0016)
	#2, #4	0.035 (0.0014)

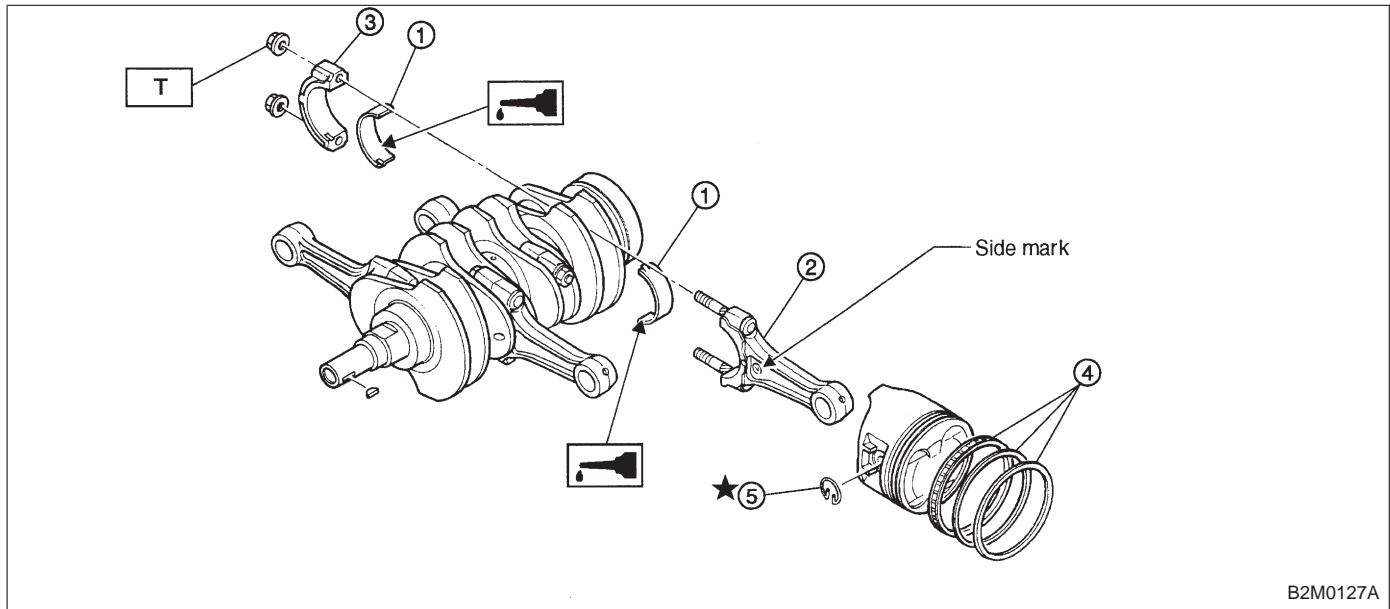
**D: ASSEMBLY****1. CRANKSHAFT AND PISTON**

**Tightening torque: N·m (kg·m, ft·lb)**  
**T: 44±2 (4.5±0.2, 32.5±1.4)**

1) Install connecting rod bearings on connecting rods and connecting rod caps.

**CAUTION:**

**Apply oil to the surfaces of the connecting rod bearings.**

2) Install connecting rod on crankshaft.

**CAUTION:**

**Position each connecting rod with the side marked facing forward.**

3) Install connecting rod cap with connecting rod nut.

Ensure the arrow on connecting rod cap faces the front during installation.

**CAUTION:**

- Each connecting rod has its own mating cap. Make sure that they are assembled correctly by checking their matching number.

- When tightening the connecting rod nuts, apply oil on the threads.

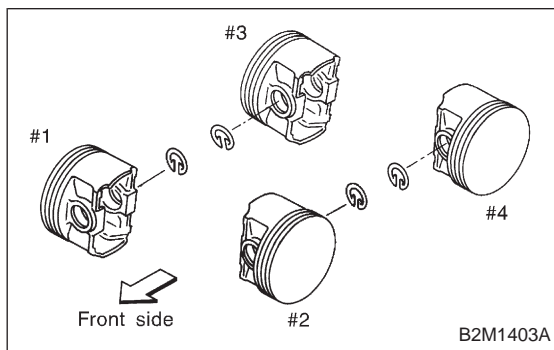
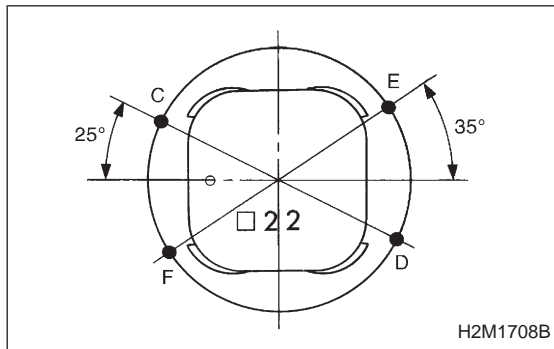
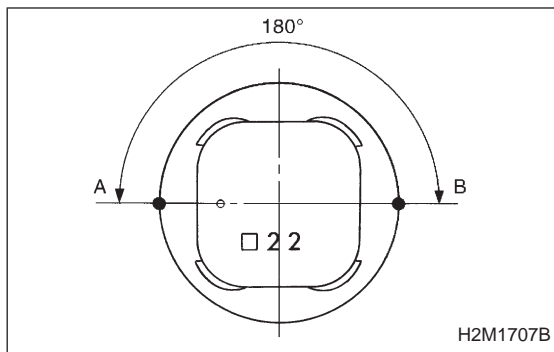

#### 4) Installation of piston rings and oil ring

(1) Install oil ring spacer, upper rail and lower rail in this order by hand. Then install second ring and top ring with a piston ring expander.

(2) Position the top ring gap at A or B in the Figure.

(3) Position the second ring gap at 180° on the reverse side for the top ring gap.

(4) Position the upper rail gap at C or D in the Figure.

(5) Position the expander gap at 180° of the reverse side for the upper rail gap.

(6) Position the lower rail gap at E or F in the Figure.

#### CAUTION:

- Ensure ring gaps do not face the same direction.
- Ensure ring gaps are not within the piston skirt area.

#### 5) Install circlip.

Install circlips in piston holes located opposite service holes in cylinder block, when positioning all pistons in the corresponding cylinders.

#### CAUTION:

**Use new circlips.**

#### NOTE:

Piston front mark "○" facer toward front of engine.

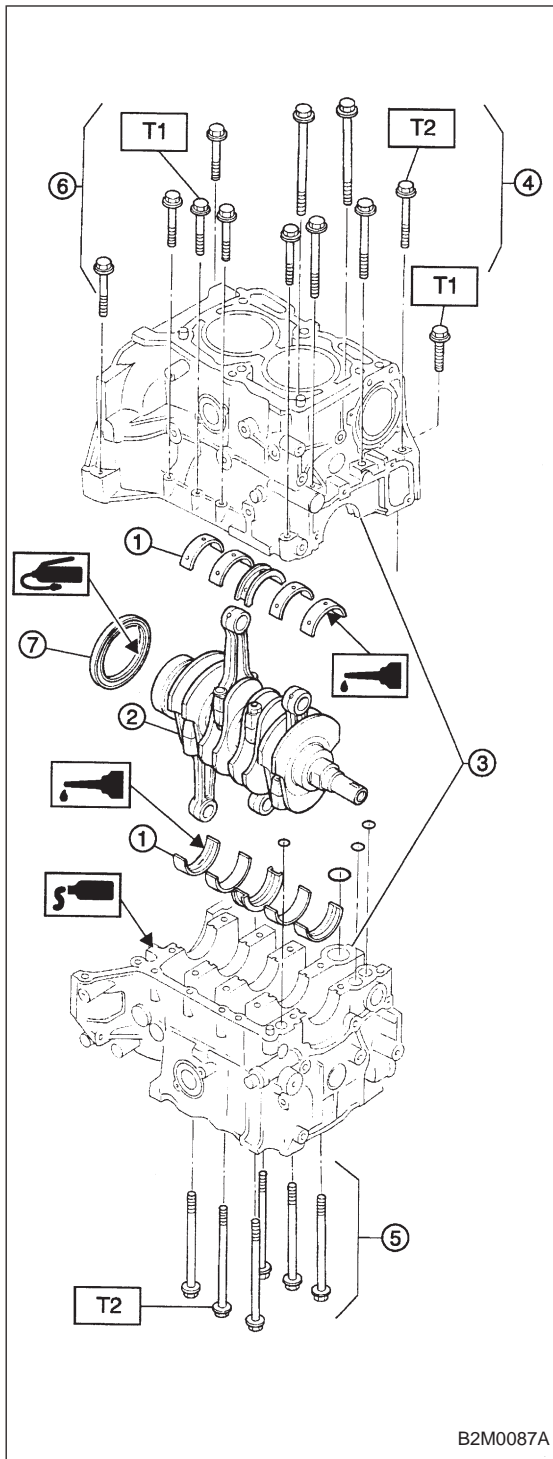

**2. CYLINDER BLOCK**

1) Install ST to cylinder block, then install crankshaft bearings.

ST 499817000 ENGINE STAND

**CAUTION:**

Remove oil the mating surface of bearing and cylinder block before installation. Also apply a coat of engine oil to crankshaft pins.

2) Position crankshaft on the #2 and #4 cylinder block.

**Tightening torque:**

**T1:  $25 \pm 2$  N·m ( $2.5 \pm 0.2$  kg-m,  $18.1 \pm 1.4$  ft-lb)**

**T2:  $47 \pm 3$  N·m ( $4.8 \pm 0.3$  kg-m,  $34.7 \pm 2.2$  ft-lb)**

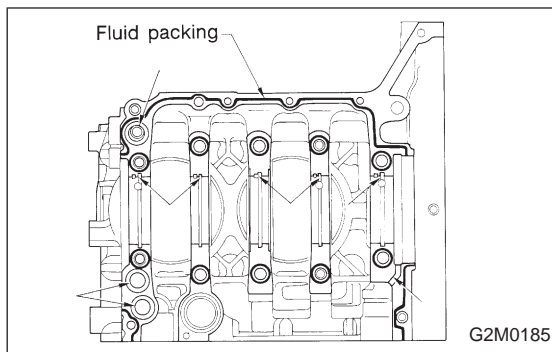

3) Apply fluid packing to the mating surface of #1 and #3 cylinder block, and position it on #2 and #4 cylinder block.

**Fluid packing:**

**THREE BOND 1215 or equivalent**

**CAUTION:**

**Do not allow fluid packing to jut into O-ring grooves, oil passages, bearing grooves, etc.**

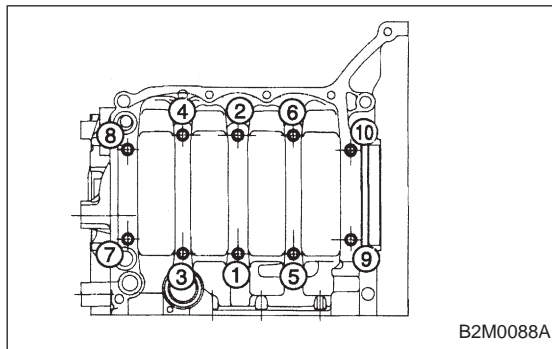

4) Temporarily tighten 10 mm cylinder block connecting bolts in numerical order shown in Figure.

5) Tighten 10 mm cylinder block connecting bolts in numerical order.

**Tightening torque:**

**$47 \pm 3 \text{ N}\cdot\text{m}$  ( $4.8 \pm 0.3 \text{ kg}\cdot\text{m}$ ,  $34.7 \pm 2.2 \text{ ft}\cdot\text{lb}$ )**

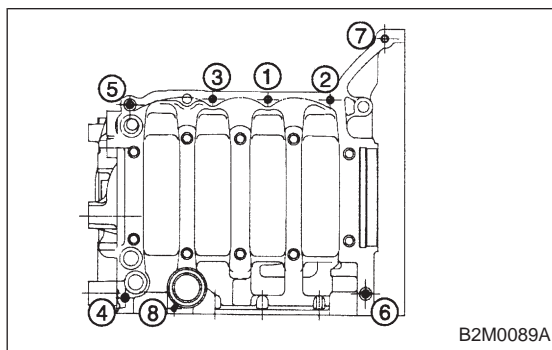

6) Tighten 8 mm and 6 mm cylinder block connecting bolts in numerical order shown in Figure.

**Tightening torque:**

① — ⑦:  **$25 \pm 2 \text{ N}\cdot\text{m}$**

**( $2.5 \pm 0.2 \text{ kg}\cdot\text{m}$ ,  $18.1 \pm 1.4 \text{ ft}\cdot\text{lb}$ )**

⑧:  **$6.4 \text{ N}\cdot\text{m}$  ( $0.65 \text{ kg}\cdot\text{m}$ ,  $4.7 \text{ ft}\cdot\text{lb}$ )**

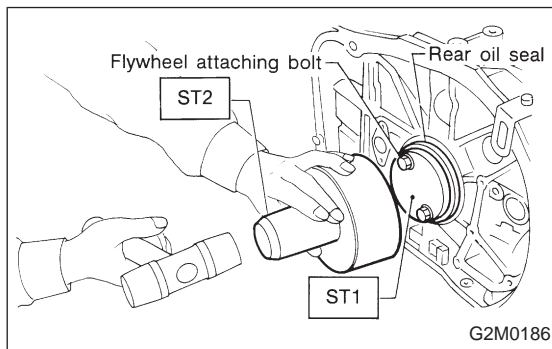

7) Install rear oil seal by using ST1 and ST2.

ST1 499597100 OIL SEAL GUIDE

ST2 499587200 OIL SEAL INSTALLER

3. PISTON AND PISTON PIN (#1 AND #2)

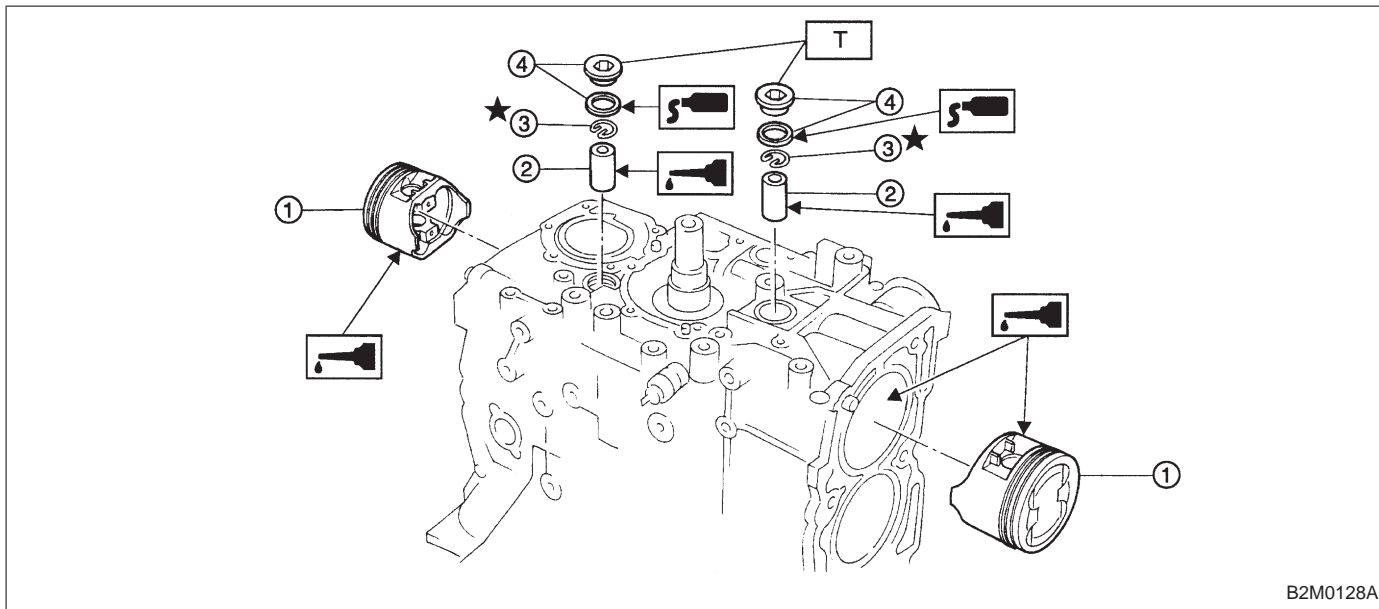

**Tightening torque: N·m (kg·m, ft·lb)**  
**T: 69±7 (7.0±0.7, 50.6±5.1)**

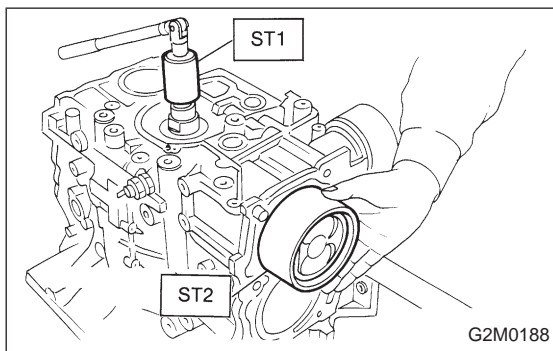

- 1) Installing piston
  - (1) Turn cylinder block so that #1 and #2 cylinders face upward.
  - (2) Using ST1, turn crankshaft so that #1 and #2 connecting rods are set at bottom dead center.

ST1 499987500 CRANKSHAFT SOCKET

- (3) Apply a coat of engine oil to pistons and cylinders and insert pistons in their cylinders by using ST2.

ST2 498747100 PISTON GUIDE

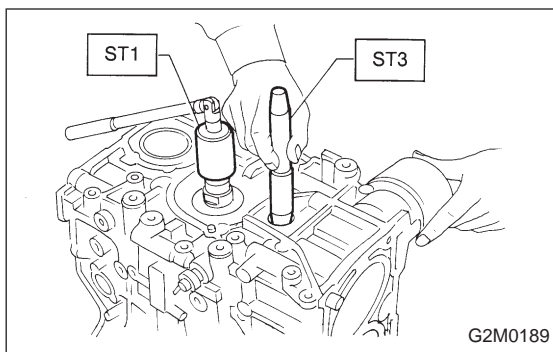

- 2) Installing piston pin

- (1) Insert ST3 into service hole to align piston pin hole with connecting rod small end.

**CAUTION:**

**Apply a coat of engine oil to ST3 before insertion.**

ST3 499017100 PISTON PIN GUIDE

(2) Apply a coat of engine oil to piston pin and insert piston pin into piston and connecting rod through service hole.

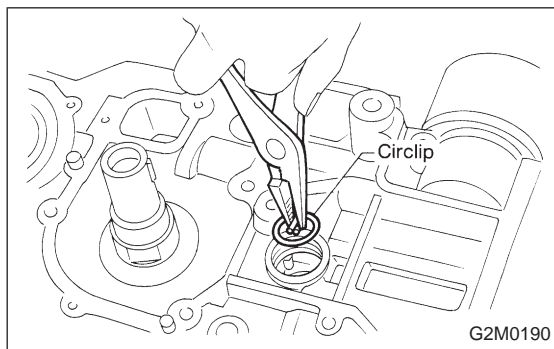

(3) Install circlip.

**CAUTION:**  
Use new circlips.

(4) Install service hole plug and gasket.

**CAUTION:**  
Use a new gasket and apply a coat of fluid packing to it before installation.

**Fluid packing:**  
*THREE BOND 1215 or equivalent*

4. PISTON AND PISTON PIN (#3 AND #4)

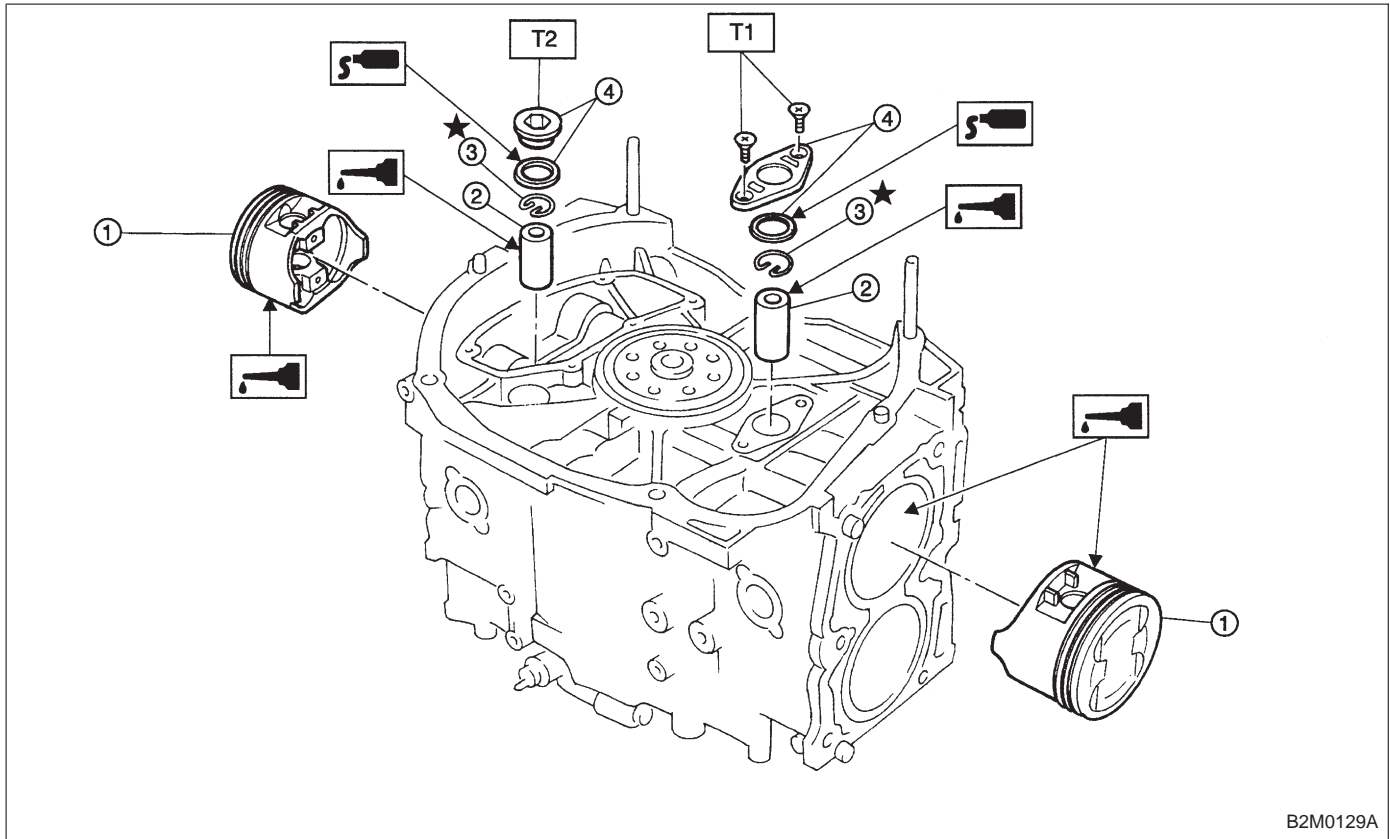

B2M0129A

**Tightening torque: N·m (kg·m, ft·lb)**  
**T1: 6.4 (0.65, 4.7)**  
**T2: 69±7 (7.0±0.7, 50.6±5.1)**

Turn cylinder block so that #3 and #4 cylinders face upward. Using the same procedures as used for #1 and #2 cylinders, install pistons and piston pins.



## E: INSTALLATION

## 1. OIL PUMP AND ENGINE COOLANT PUMP

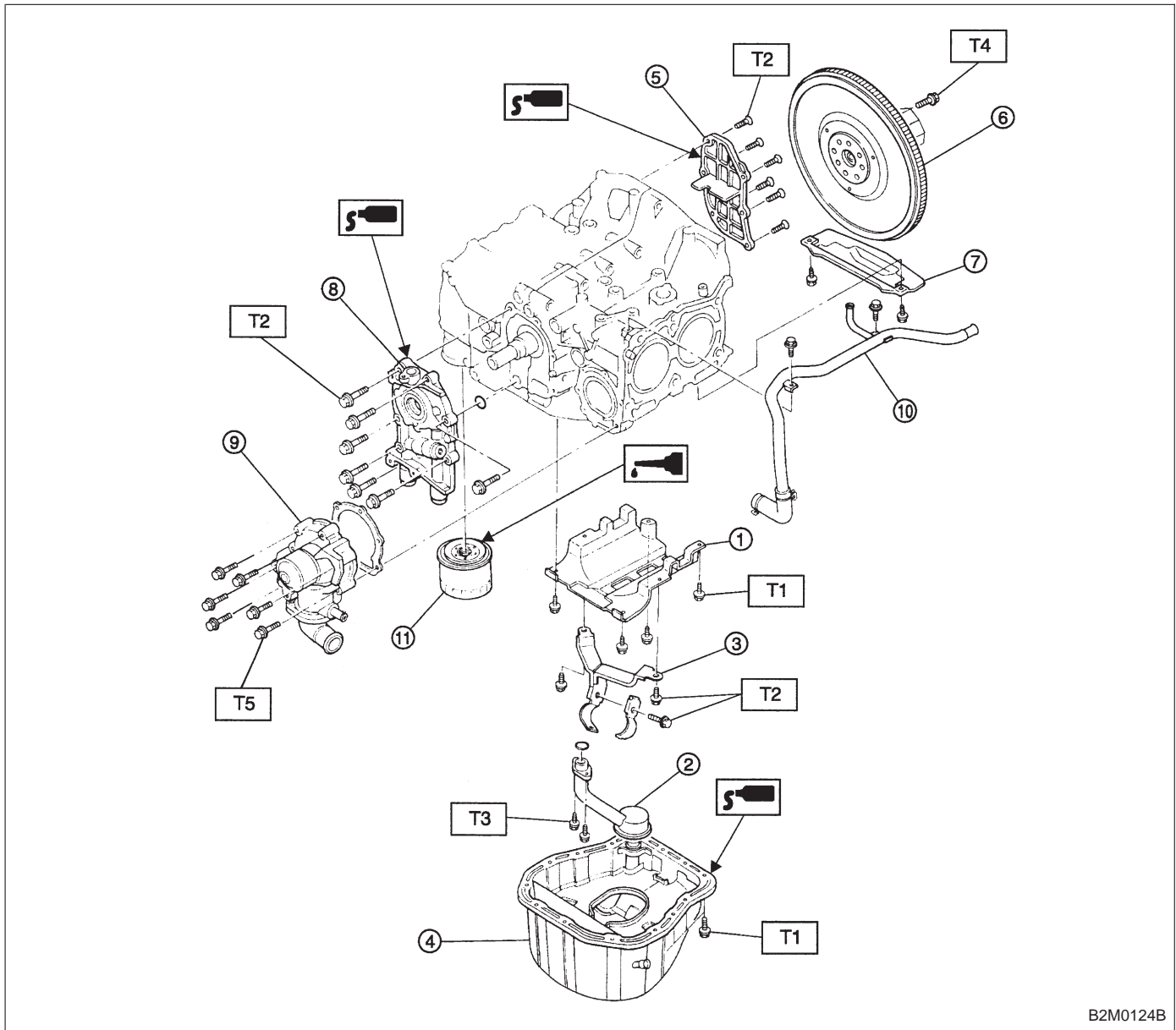

B2M0124B

**Tightening torque: N·m (kg·m, ft·lb)**

T1: 5 (0.5, 3.6)

T2: 6.4 (0.65, 4.7)

T3: 10 (1.0, 7)

T4:  $72 \pm 3$  ( $7.3 \pm 0.3$ ,  $52.8 \pm 2.2$ )T5: First  $12 \pm 2$  ( $1.2 \pm 0.2$ ,  $8.7 \pm 1.4$ )Second  $12 \pm 2$  ( $1.2 \pm 0.2$ ,  $8.7 \pm 1.4$ )

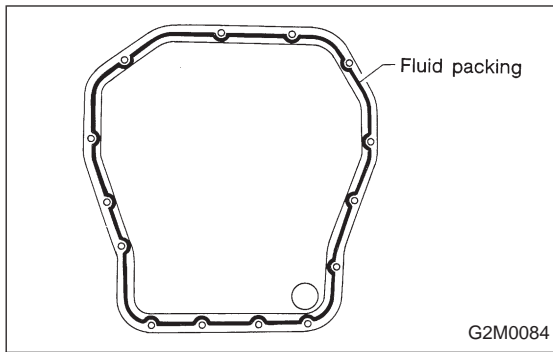

- 1) Install baffle plate.
- 2) Install oil strainer and O-ring
- 3) Install oil strainer stay.
- 4) Apply fluid packing to matching surfaces and install oil pan.

**Fluid packing:**  
**THREE BOND 1207C or equivalent**

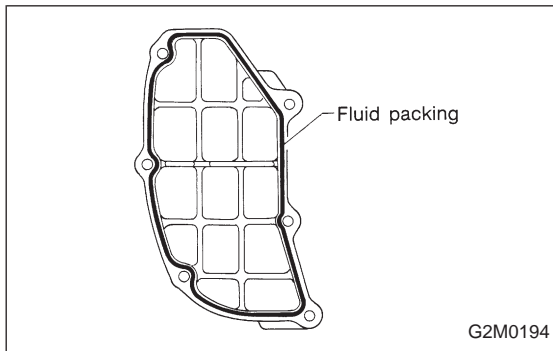

- 5) Apply fluid packing to matching surfaces and install oil separator cover.

**Fluid packing:**  
**THREE BOND 1215 or equivalent**

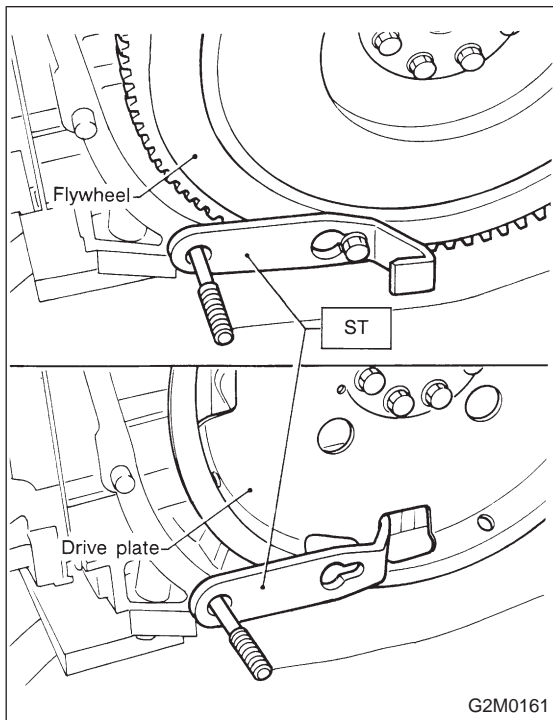

- 6) Install flywheel or drive plate.  
 To lock crankshaft, use ST.  
 ST 498497100 CRANKSHAFT STOPPER
- 7) Install housing cover.

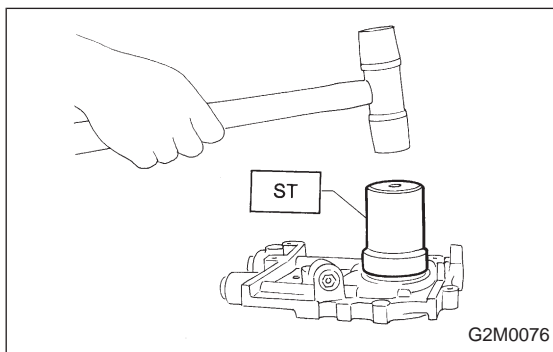

- 8) Installation of oil pump
  - (1) Discard front oil seal after removal. Replace with a new one by using ST.
 ST 499587100 OIL SEAL INSTALLER

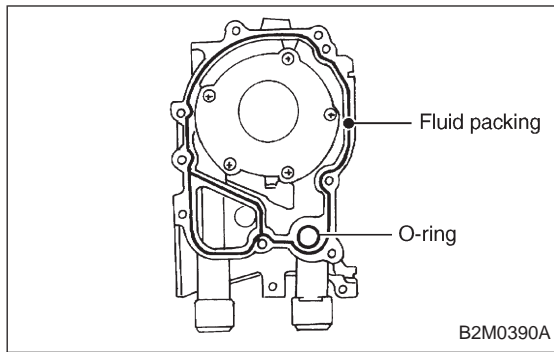

(2) Apply fluid packing to matching surface of oil pump.

**Fluid packing:**

**THREE BOND 1215 or equivalent**

(3) Install oil pump on cylinder block. Be careful not to damage oil seal during installation.

**CAUTION:**

- Do not forget to install O-ring and seal when installing oil pump.
- Align flat surface of oil pump's inner rotor with crankshaft before installation.

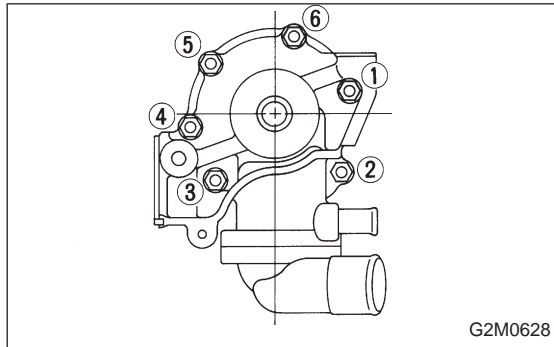

9) Install engine coolant pump and gasket.

**CAUTION:**

- Be sure to use a new gasket.
- When installing engine coolant pump, tighten bolts in two stages in numerical sequence as shown in Figure.

10) Install engine coolant pipe.

11) Install oil filter.

**2. RELATED PARTS**

1) Install cylinder head and intake manifold.

<Ref. to 2-3 [W6E0].>

2) Install timing belt, camshaft sprocket and related parts.

<Ref. to 2-3 [W3C0].>

# 1. Engine Trouble in General

Numbers shown in the chart refer to the possibility of reason for the trouble in order (“Very often” to “Rarely”)

- 1 — Very often
- 2 — Sometimes
- 3 — Rarely

TROUBLE												POSSIBLE CAUSE	
Engine will not start.				Rough idle and engine stall	Low output, hesitation and poor acceleration	Surging	Engine does not return to idle.	Dieseling (Run-on)	After burning in exhaust system	Knocking	Excessive engine oil consumption		Excessive fuel consumption
Starter does not turn.	Initial combustion does not occur.	Initial combustion occurs.	Engine stalls after initial combustion.										
													STARTER
													● Defective battery-to-starter harness
													● Defective starter switch
													● Defective inhibitor switch
													● Defective starter
													BATTERY
													● Poor terminal connection
													● Run-down battery
													● Defective charging system
	1	1	1	1	1	1	1	1	1	1		1	Fuel injection system <Ref. to 2-7 On-Board Diagnostics II System.>

1. Engine Trouble in General

TROUBLE														
Engine will not start.				Rough idle and engine stall	Low output, hesitation and poor acceleration	Surging	Engine does not return to idle.	Dieseling (Run-on)	After burning in exhaust system	Knocking	Excessive engine oil consumption	Excessive fuel consumption		
Starter does not turn.	Initial combustion does not occur.	Initial combustion occurs.	Engine stalls after initial combustion.											
														INTAKE SYSTEM
			2	1	1	1			3					● Loosened or cracked intake air pipe
			3	1	1	1			3		1			● Loosened or cracked blow-by hose
			3	1	2	1	1		2					● Loosened or cracked vacuum hose
		2	2	2	2	2								● Defective intake manifold gasket
		2	2	2	2	2								● Defective throttle body gasket
				3	2	2			2		2			● Defective PCV valve
				2	2	2			3	2	3			● Loosened oil filler cap
			3	3	1	2						1		● Dirty air cleaner element
														FUEL LINE
	1	3		3	2	2								● Defective fuel pump and relay
		3	3	3	2	2								● Clogged fuel line
	2	2	2	2	3	3								● Lack of or insufficient fuel
														BELT
	2	2	2											● Defective
	2	2	2	3	2	2			2	2		2		● Defective timing
														FRICITION
3														● Seizure of crankshaft and connecting rod bearing
3														● Seized camshaft
3														● Seized or stuck piston and cylinder
														COMPRESSION
	3	3	3	2	2	2			2	3		2		● Defective hydraulic lash adjuster
	3	3	3	2	2	3			3			3		● Loosened spark plugs or defective gasket
	3	3	3	2	2	3			3			3		● Loosened cylinder head bolts or defective gasket
	3	3	3	2	2	3			2			2		● Improper valve seating
	3	3	3	3	3	3			3		1	3		● Defective valve stem
	2	2	2	2	2	3			3			3		● Worn or broken valve spring
	3	3	3	2	3	3			3		1	2		● Worn or stuck piston rings, cylinder and piston
	2	2	2	1	1	1			1	2		2		● Incorrect valve timing
	2	2	2	2	2	2								● Improper engine oil (low viscosity)

TROUBLE													
Engine will not start.				Rough idle and engine stall	Low output, hesitation and poor acceleration	Surging	Engine does not return to idle.	Dieseling (Run-on)	After burning in exhaust system	Knocking	Excessive engine oil consumption	Excessive fuel consumption	
Starter does not turn.	Initial combustion does not occur.	Initial combustion occurs.	Engine stalls after initial combustion.										
													LUBRICATION SYSTEM
				2	2				3			3	● Incorrect oil pressure
											2		● Loosened oil pump attaching bolts and defective gasket
											2		● Defective oil filter seal
											2		● Defective crankshaft oil seal
				3							2		● Defective rocker cover gasket
											2		● Loosened oil drain plug or defective gasket
											2		● Loosened oil pan fitting bolts or defective oil pan
													COOLING SYSTEM
				3	3	2		2		1			● Overheating
					3				3			3	● Over cooling
													OTHERS
				1	1	3			3				● Malfunction of Evaporative Emission Control System
				2			1						● Stuck or damaged throttle valve
				3			2	2				2	● Accelerator cable out of adjustment

## 2. Engine Noise

Valve lash adjusters may make clicking noise once engine starts. It is normal if clicking noise ceases after a few minutes.

If clicking noise continues after a few minutes, check engine oil level and add oil if necessary.

Then, do as follows to cease clicking noise.

- 1) Warm-up engine for five minutes.
  - 2) Turn ignition switch OFF.
  - 3) Connect test mode connector.
  - 4) Start the engine and run it at approximately 2,000 rpm for twenty minutes.
  - 5) Turn ignition switch OFF.
  - 6) Disconnect test mode connector.
  - 7) Start the engine and check that clicking noise is ceased.
- If noise still exists, conduct troubleshooting procedures in accordance with the following table.

### CAUTION:

**Do not disconnect spark plug cord while engine is running.**

Type of sound	Condition	Possible cause
Regular clicking sound	Sound increases as engine speed increases.	Valve mechanism is defective. <ul style="list-style-type: none"> <li>● Broken lash adjuster</li> <li>● Worn valve rocker</li> <li>● Worn camshaft</li> <li>● Broken valve spring</li> <li>● Worn valve lifter hole</li> </ul>
Heavy and dull clank	Oil pressure is low.	<ul style="list-style-type: none"> <li>● Worn crankshaft main bearing</li> <li>● Worn connecting rod bearing (big end)</li> </ul>
	Oil pressure is normal.	<ul style="list-style-type: none"> <li>● Loose flywheel mounting bolts</li> <li>● Damaged engine mounting</li> </ul>
High-pitched clank (Spark knock)	Sound is noticeable when accelerating with an overload.	<ul style="list-style-type: none"> <li>● Ignition timing advanced</li> <li>● Accumulation of carbon inside combustion chamber</li> <li>● Wrong spark plug</li> <li>● Improper gasoline</li> </ul>
Clank when engine speed is medium (1,000 to 2,000 rpm).	Sound is reduced when fuel injector connector of noisy cylinder is disconnected. (NOTE*)	<ul style="list-style-type: none"> <li>● Worn crankshaft main bearing</li> <li>● Worn bearing at crankshaft end of connecting rod</li> </ul>
Knocking sound when engine is operating under idling speed and engine is warm.	Sound is reduced when fuel injector connector of noisy cylinder is disconnected. (NOTE*)	<ul style="list-style-type: none"> <li>● Worn cylinder liner and piston ring</li> <li>● Broken or stuck piston ring</li> <li>● Worn piston pin and hole at piston end of connecting rod</li> </ul>
	Sound is not reduced if each fuel injector connector is disconnected in turn. (NOTE*)	<ul style="list-style-type: none"> <li>● Unusually worn valve lifter</li> <li>● Worn cam gear</li> <li>● Worn camshaft journal bore in crankcase</li> </ul>
Squeaky sound	—	<ul style="list-style-type: none"> <li>● Insufficient generator lubrication</li> </ul>
Rubbing sound	—	<ul style="list-style-type: none"> <li>● Defective generator brush and rotor contact</li> </ul>
Gear scream when starting engine	—	<ul style="list-style-type: none"> <li>● Defective ignition starter switch</li> <li>● Worn gear and starter pinion</li> </ul>
Sound like polishing glass with a dry cloth	—	<ul style="list-style-type: none"> <li>● Loose drive belt</li> <li>● Defective engine coolant pump shaft</li> </ul>

Type of sound	Condition	Possible cause
Hissing sound	—	<ul style="list-style-type: none"><li>● Loss of compression</li><li>● Air leakage in air intake system, hoses, connections or manifolds</li></ul>
Timing belt noise	—	<ul style="list-style-type: none"><li>● Loose timing belt</li><li>● Belt contacting case/adjacent part</li></ul>

**NOTE\*:**

When disconnecting fuel injector connector, Malfunction Indicator Light (CHECK ENGINE light) illuminates and trouble code is stored in ECM memory.

Therefore, carry out the CLEAR MEMORY MODE and INSPECTION MODE after connecting fuel injector connector. (Ref. to 2-7 On-Board Diagnostics II System.)



## 1. Lubrication System

## A: SPECIFICATIONS

Lubrication method				Forced lubrication	
Oil pump	Pump type			Trochoid type	
	Number of teeth	Inner rotor		9	
		Outer rotor		10	
	Outer rotor diameter x thickness			78 x 9 mm (3.07 x 0.35 in)	
	Tip clearance between inner and outer rotor			STANDARD	0.04 — 0.14 mm (0.0016 — 0.0055 in)
				LIMIT	0.18 mm (0.0071 in)
	Side clearance between inner rotor and pump case			STANDARD	0.02 — 0.07 mm (0.0008 — 0.0028 in)
				LIMIT	0.15 mm (0.0059 in)
	Case clearance between outer rotor and pump case			STANDARD	0.10 — 0.175 mm (0.0039 — 0.0069 in)
				LIMIT	0.20 mm (0.0079 in)
Capacity at 80°C (176°F)	700 rpm	Discharge	- pressure	98 kPa (1.0 kg/cm <sup>2</sup> , 14 psi) or more	
			- quantity	4.2 ℓ (4.4 US qt, 3.7 Imp qt)/min.	
	5,000 rpm	Discharge	- pressure	294 kPa (3.0 kg/cm <sup>2</sup> , 43 psi) or more	
			- quantity	42.0 ℓ (11.10 US gal, 9.24 Imp gal)/min.	
Relief valve operation pressure				490 kPa (5.0 kg/cm <sup>2</sup> , 71 psi)	
Oil filter	Type			Full-flow filter type	
	Filtration area			1,000 cm <sup>2</sup> (155 sq in)	
	By-pass valve opening pressure			157 kPa (1.6 kg/cm <sup>2</sup> , 23 psi)	
	Outer diameter x width			80 x 70 mm (3.15 x 2.76 in)	
	Oil filter to engine thread size			M 20 x 1.5	
Relief valve (on rocker shaft) operation pressure				69 kPa (0.7kg/cm <sup>2</sup> , 10 psi)	
Oil pressure switch	Type			Immersed contact point type	
	Working voltage — wattage			12 V — 3.4 W or less	
	Warning light activation pressure			14.7 kPa (0.15 kg/cm <sup>2</sup> , 2.1 psi)	
	Proof pressure			More than 981 kPa (10 kg/cm <sup>2</sup> , 142 psi)	
Oil pan capacity				4.0 ℓ (4.2 US qt, 3.5 Imp qt)	

1. Lubrication System

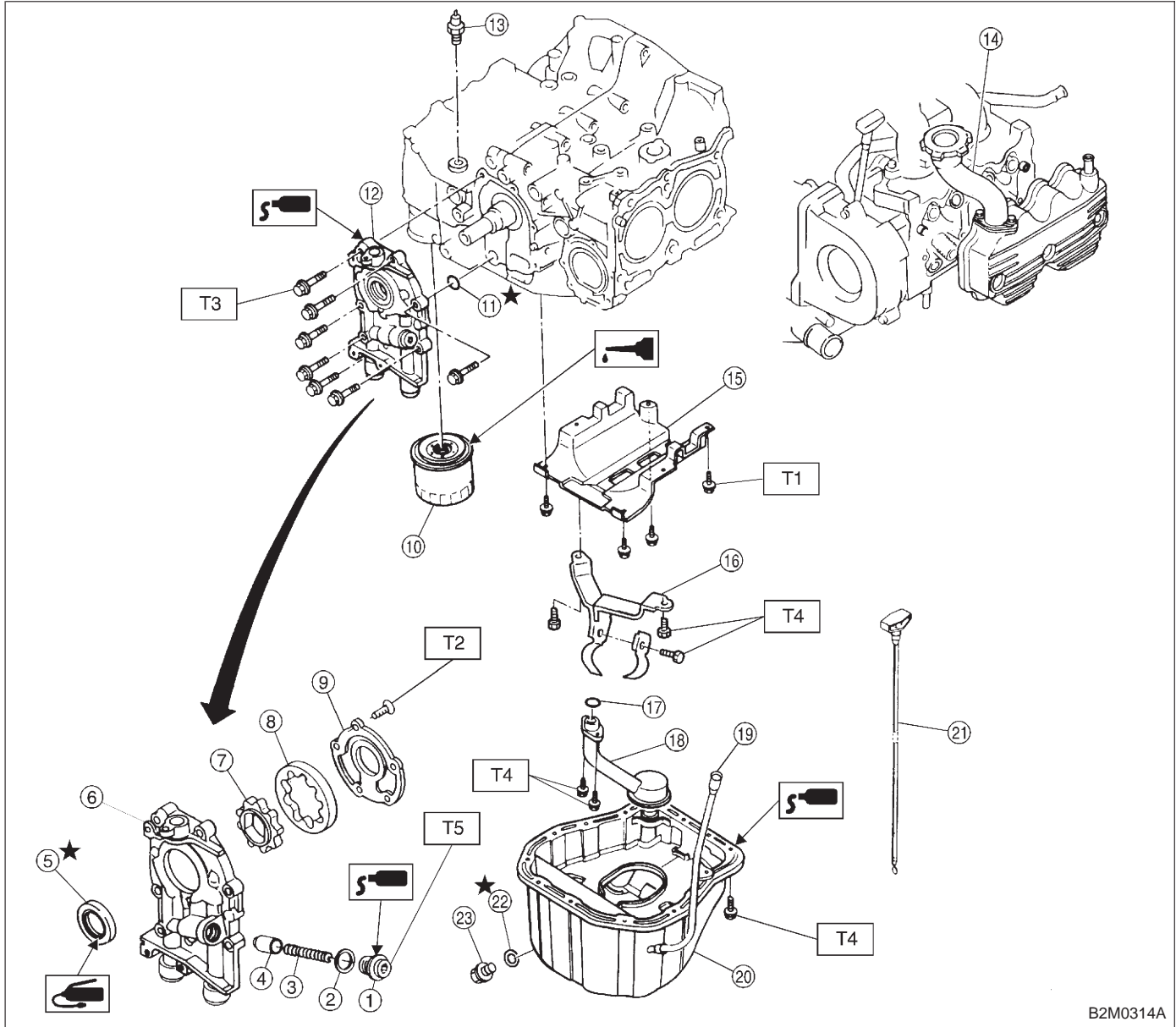

B2M0314A

- ① Plug
- ② Washer
- ③ Relief valve spring
- ④ Relief valve
- ⑤ Oil seal
- ⑥ Oil pump case
- ⑦ Inner rotor
- ⑧ Outer rotor
- ⑨ Oil pump cover
- ⑩ Oil filter
- ⑪ O-ring
- ⑫ Oil pump ASSY
- ⑬ Oil pressure switch
- ⑭ Oil filler duct

- ⑮ Baffle plate
- ⑯ Oil strainer stay
- ⑰ O-ring
- ⑱ Oil strainer
- ⑲ Oil level gauge guide
- ⑳ Oil pan
- ㉑ Oil level gauge
- ㉒ Washer
- ㉓ Drain plug

**Tightening torque: N-m (kg-m, ft-lb)**

**T1: 5 (0.5, 3.6)**

**T2:  $5_{-0}^{+1}$  ( $0.5_{-0}^{+0.1}$ ,  $3.6_{-0}^{+0.7}$ )**

**T3: 6.4 (0.65, 4.7)**

**T4: 9.8 (1.0, 7.0)**

**T5:  $44.1 \pm 3.4$  ( $4.5 \pm 0.35$ ,  $32.5 \pm 2.5$ )**

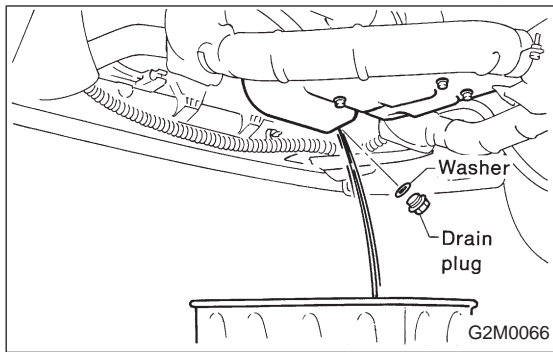

## 1. Oil Pump

### A: REMOVAL

1) Drain engine oil.

Set container under the vehicle, and remove drain plug from oil pan.

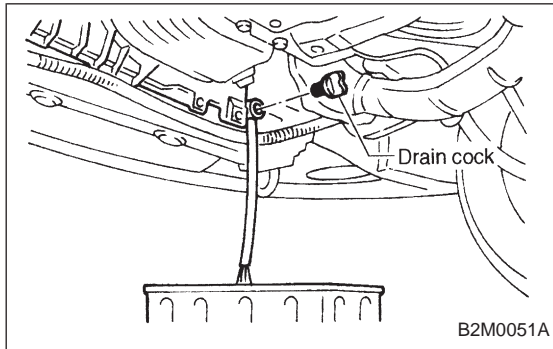

2) Drain coolant.

Set container under the vehicle, and remove drain cock from radiator.

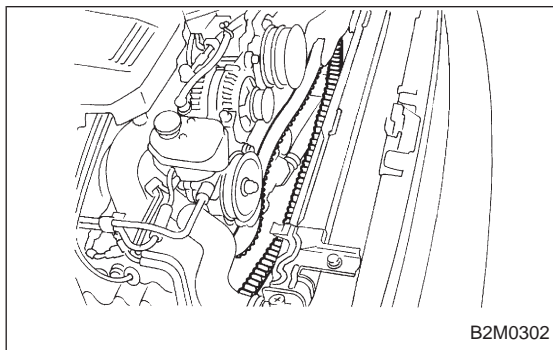

3) Remove belt covers, timing belt and related parts.  
<Ref. to 1-5 [02A0].>

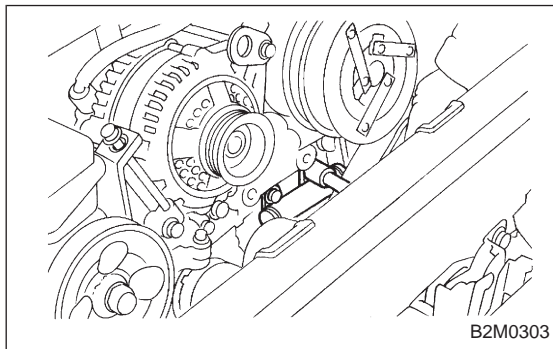

4) Remove belt tensioner bracket.

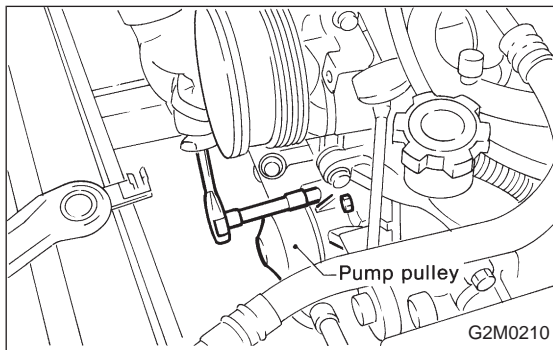

5) Remove left cam sprocket and left belt cover No. 2.

6) Remove water pump.

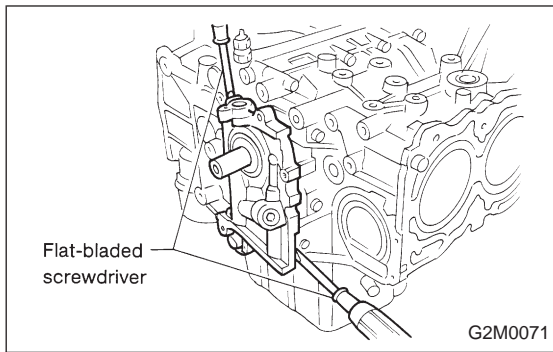

7) Remove oil pump by using flat-bladed screwdriver.

**CAUTION:**

Be careful not to scratch mating surfaces of cylinder block and oil pump.

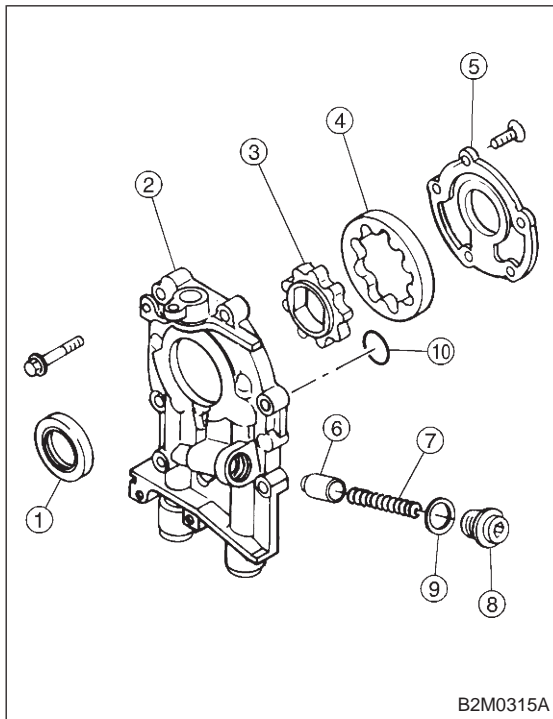

**B: DISASSEMBLY**

Remove screws which secure oil pump cover and disassemble oil pump.

Inscribe alignment marks on inner and outer rotors so that they can be replaced in their original positions during reassembly.

**CAUTION:**

Before removing relief valve, loosen plug when removing oil pump from cylinder block.

- ① Oil seal
- ② Pump case
- ③ Inner rotor
- ④ Outer rotor
- ⑤ Pump cover
- ⑥ Relief valve
- ⑦ Relief spring
- ⑧ Plug
- ⑨ Washer
- ⑩ O-ring

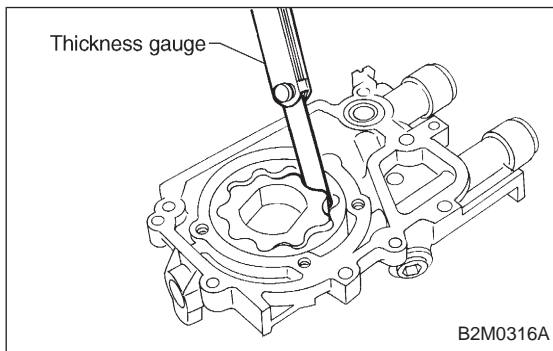

**C: INSPECTION**

**1. TIP CLEARANCE**

Measure the tip clearance of rotors. If the clearance exceeds the limit, replace rotors as a matched set.

**Tip clearance:**

**Standard**

0.04 — 0.14 mm (0.0016 — 0.0055 in)

**Limit**

0.18 mm (0.0071 in)

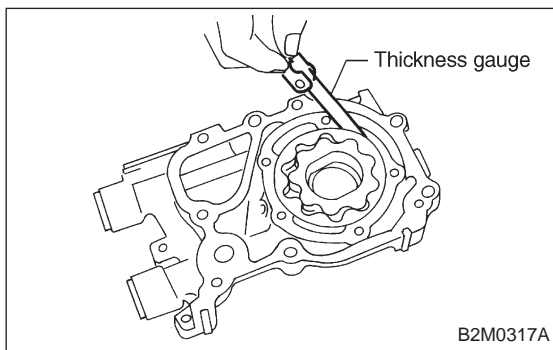

**2. CASE CLEARANCE**

Measure the clearance between the outer rotor and the cylinder block rotor housing. If the clearance exceeds the limit, replace the rotor.

**Case clearance:**

**Standard**

0.10 — 0.175 mm (0.0039 — 0.0069 in)

**Limit**

0.20 mm (0.0079 in)

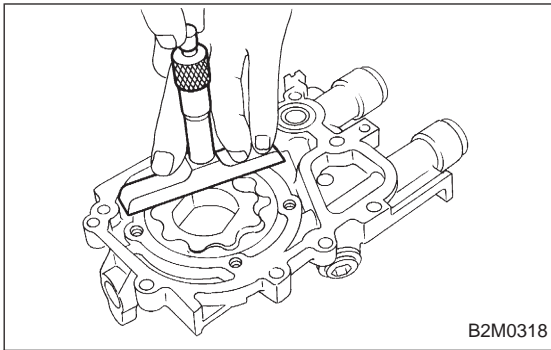

### 3. SIDE CLEARANCE

Measure clearance between oil pump inner rotor and pump cover. If the clearance exceeds the limit, replace rotor or pump body.

**Side clearance:**

**Standard**

**0.02 — 0.07 mm (0.0008 — 0.0028 in)**

**Limit**

**0.15 mm (0.0059 in)**

### 4. OIL RELIEF VALVE

Check the valve for fitting condition and damage, and the relief valve spring for damage and deterioration. Replace the parts if defective.

**Relief valve spring:**

**Free length; 71.8 mm (2.827 in)**

**Installed length; 54.7 mm (2.154 in)**

**Load when installed; 77.08 N (7.86 kg, 17.33 lb)**

### 5. OIL PUMP CASE

Check the oil pump case for worn shaft hole, clogged oil passage, worn rotor chamber, cracks, and other faults.

### 6. OIL SEAL

Check the oil seal lips for deformation, hardening, wear, etc. and replace if defective.

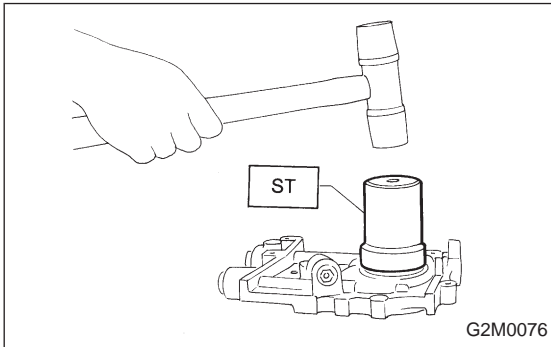

## D: ASSEMBLY

1) Install front oil seal by using ST.

ST 499587100 OIL SEAL INSTALLER

**CAUTION:**

**Use a new oil seal.**

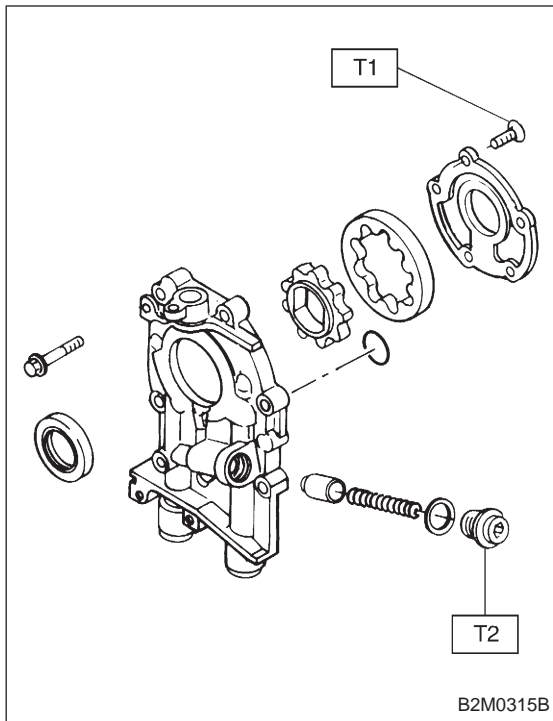

- 2) Install inner and outer rotors in their original positions.
- 3) Install oil relief valve and relief spring.
- 4) Install oil pump cover.

**Tightening torque:**

**T1:  $5_{-0}^{+1}$  N·m ( $0.5_{-0}^{+0.1}$  kg-m,  $3.6_{-0}^{+0.7}$  ft-lb)**

**T2:  $44.1 \pm 3.4$  N·m ( $4.5 \pm 0.35$  kg-m,  $32.5 \pm 2.5$  ft-lb)**

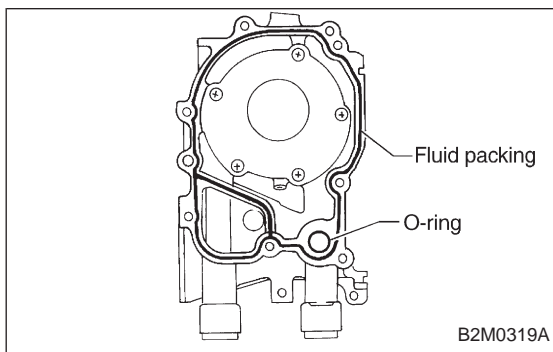

**E: INSTALLATION**

Installation is in the reverse order of removal.

Do the following:

- 1) Apply fluid packing to matching surfaces of oil pump.

**Fluid packing:**

**THREE BOND 1215 or equivalent**

- 2) Replace O-ring with a new one.
- 3) Be careful not to scratch oil seal when installing oil pump on cylinder block.

**CAUTION:**

**Apply fluid packing to oil pressure switch threads before installation.**

**Fluid packing:**

**THREE BOND 1215 or equivalent**

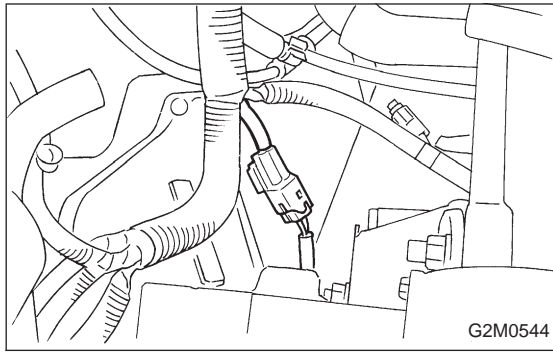

## 2. Oil Pan and Oil Strainer

### A: REMOVAL

- 1) Remove front wheels.
- 2) Remove air intake duct.
- 3) Disconnect connector from front oxygen sensor.

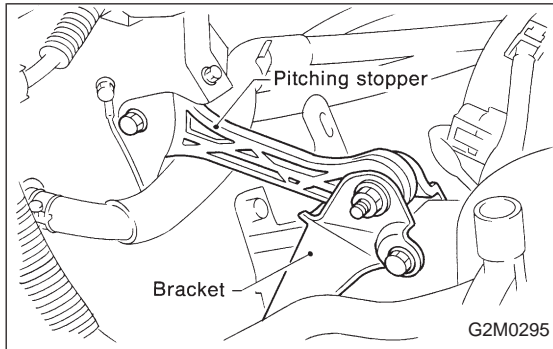

- 4) Remove pitching stopper.

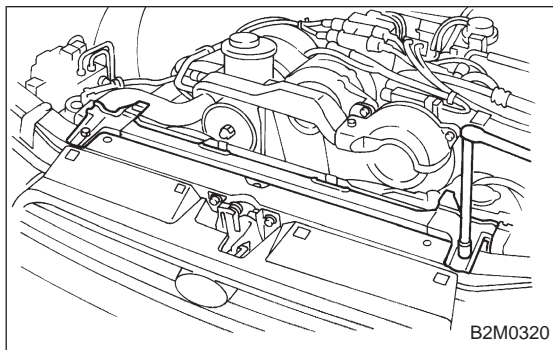

- 5) Remove radiator upper brackets.

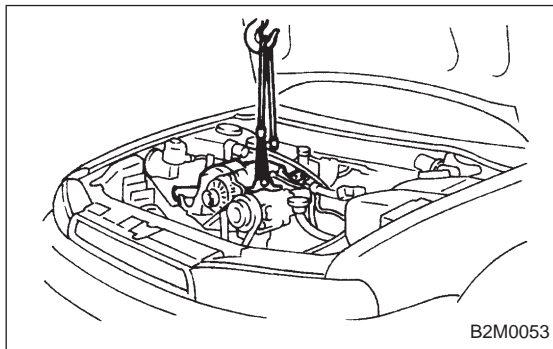

- 6) Support engine with a lifting device and wire ropes.
- 7) Lift-up the vehicle.

### CAUTION:

At this time, raise up wire ropes.

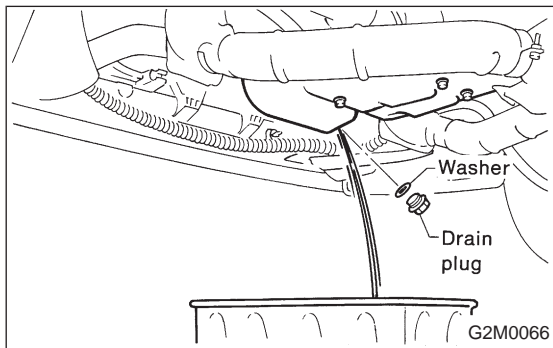

- 8) Drain engine oil.

Set container under the vehicle, and remove drain plug from oil pan.

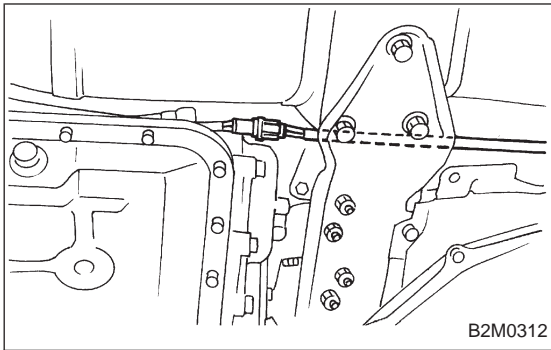

9) Disconnect connector from rear oxygen sensor.

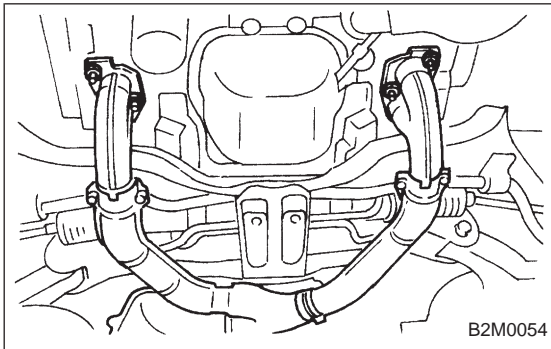

10) Remove front exhaust pipe.  
 (1) Separate front catalytic converter from center exhaust pipe.  
 (2) Remove front exhaust pipe from engine.  
 (3) Remove bolt which installs front exhaust pipe on bracket.

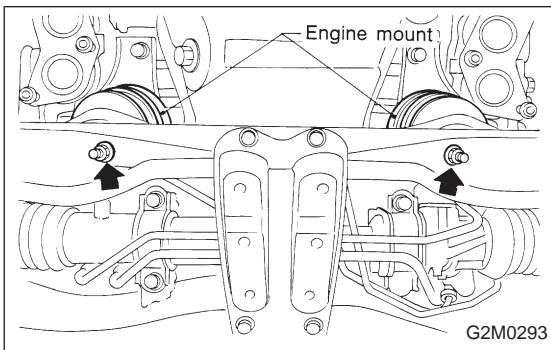

11) Remove nuts which install front cushion rubber onto front crossmember.

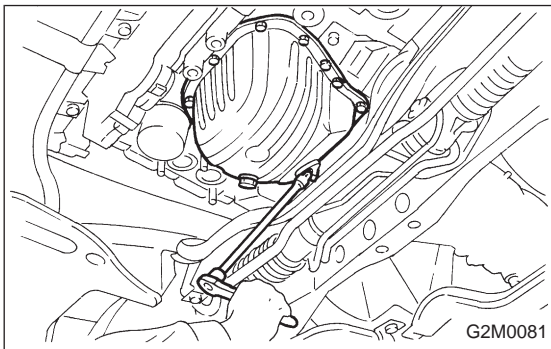

12) Remove bolts which install oil pan on cylinder block while raising up engine.  
 13) Insert oil pan cutter blade between cylinder block-to-oil pan clearance.

**CAUTION:**  
 Do not use a screwdriver or similar tool in place of oil pan cutter.

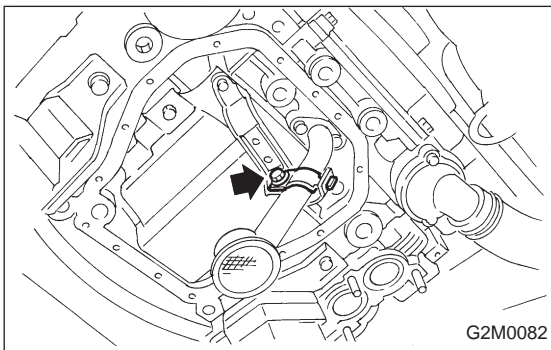

14) Separate oil strainer from oil strainer stay.



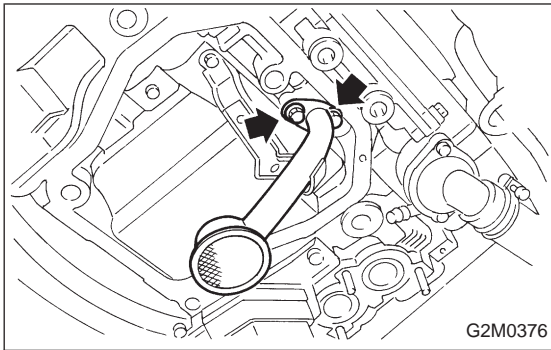

15) Remove oil strainer.

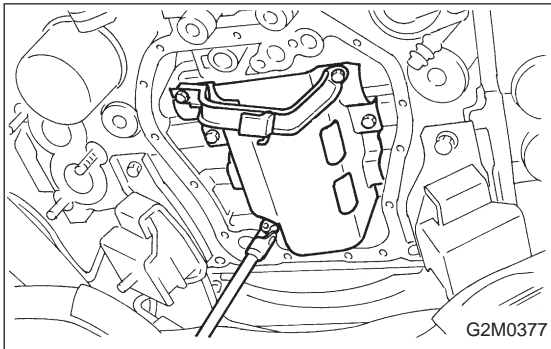

16) Remove baffle plate and oil strainer stay.

## B: INSPECTION

By visual check make sure oil pan, oil strainer, oil strainer stay and baffle plate are not damaged.

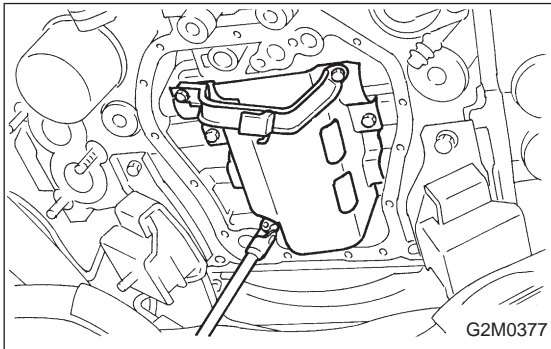

## C: INSTALLATION

### CAUTION:

Before installing oil pan, clean sealant from oil and engine block.

1) Install baffle plate and oil strainer stay.

### Tightening torque:

**5 N·m (0.5 kg-m, 3.6 ft-lb)**

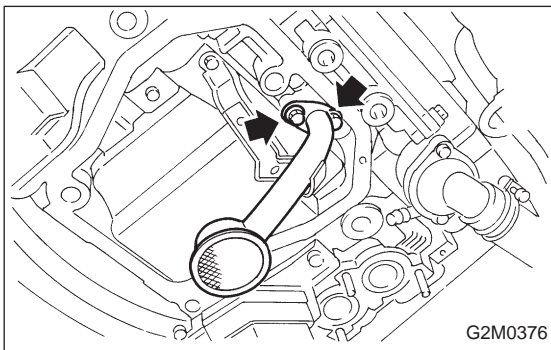

2) Install oil strainer onto baffle plate.

### CAUTION:

Replace O-ring with a new one.

### Tightening torque:

**9.8 N·m (1.0 kg-m, 7 ft-lb)**

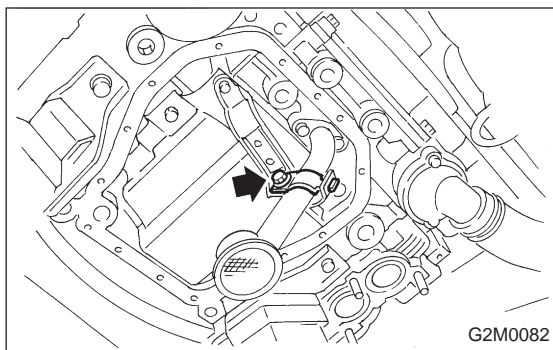

3) Hold oil strainer to oil strainer stay.

**Tightening torque:**  
**9.8 N·m (1.0 kg-m, 7 ft-lb)**

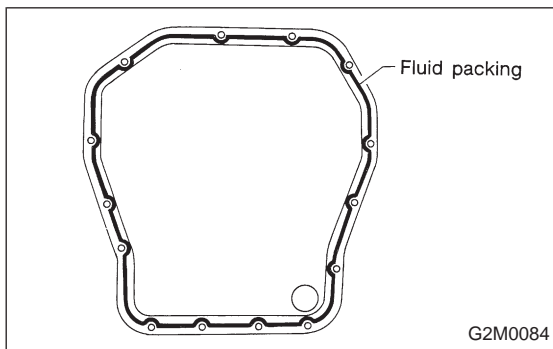

4) Apply fluid packing to mating surfaces and install oil pan.

**Fluid packing:**  
**THREE BOND 1207C or equivalent**

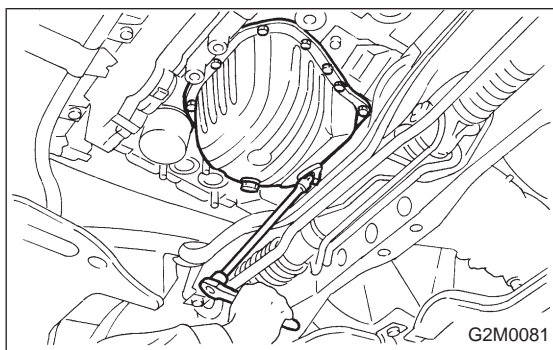

5) Tighten bolts which install oil pan onto engine block.

**Tightening torque:**  
**9.8 N·m (1.0 kg-m, 7 ft-lb)**

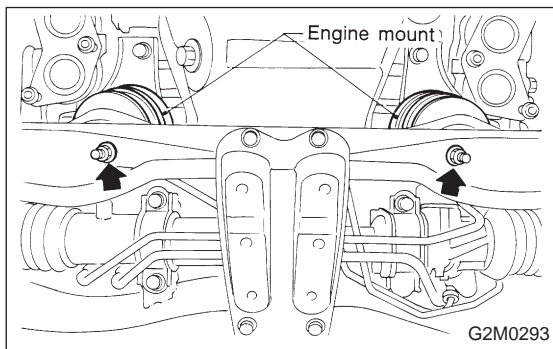

6) Lower engine onto front crossmember.

7) Tighten nuts which install front cushion rubber onto front crossmember.

**Tightening torque:**  
**69±15 N·m (7.0±1.5 kg-m, 51±11 ft-lb)**

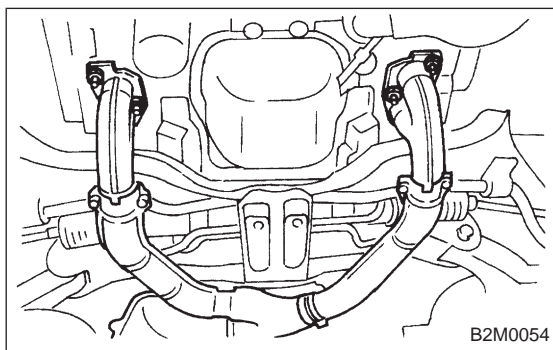

8) Install front exhaust pipe.

**CAUTION:**  
**Always use the new gaskets.**

- (1) Place front exhaust pipe on bracket.
- (2) Tighten nuts which install front exhaust pipe on engine.

**Tightening torque:**  
**30±5 N·m (3.1±0.5 kg-m, 22.4±3.6 ft-lb)**

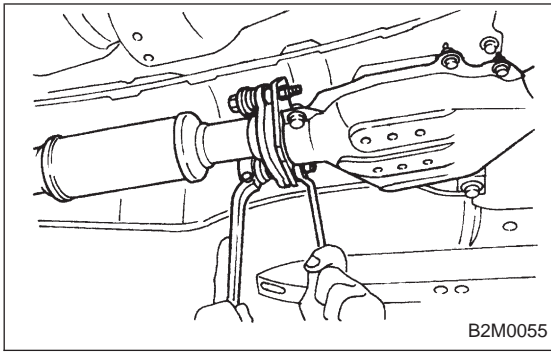

(3) Tighten nuts which install front catalytic converter to center exhaust pipe.

**Tightening torque:**

**$35\pm 5 \text{ N}\cdot\text{m}$  ( $3.6\pm 0.5 \text{ kg}\cdot\text{m}$ ,  $26.0\pm 3.6 \text{ ft}\cdot\text{lb}$ )**

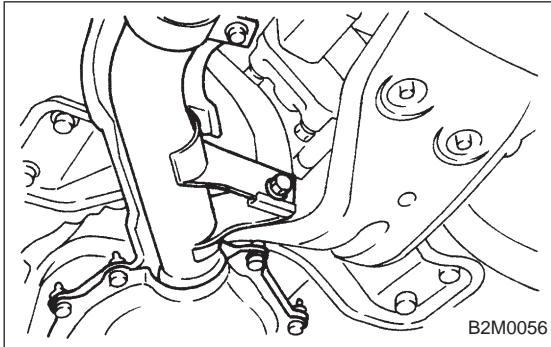

(4) Tighten bolt which installs front exhaust pipe on bracket.

**Tightening torque:**

**$24\pm 3 \text{ N}\cdot\text{m}$  ( $2.4\pm 0.3 \text{ kg}\cdot\text{m}$ ,  $17.4\pm 2.2 \text{ ft}\cdot\text{lb}$ )**

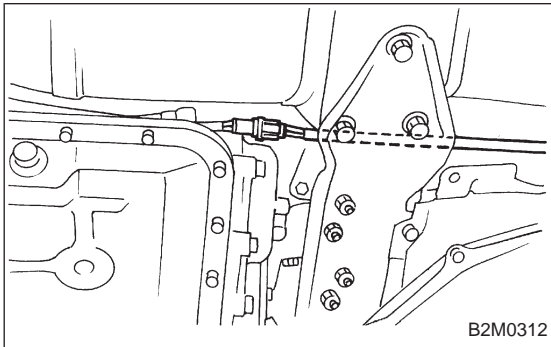

9) Connect connector to rear oxygen sensor.

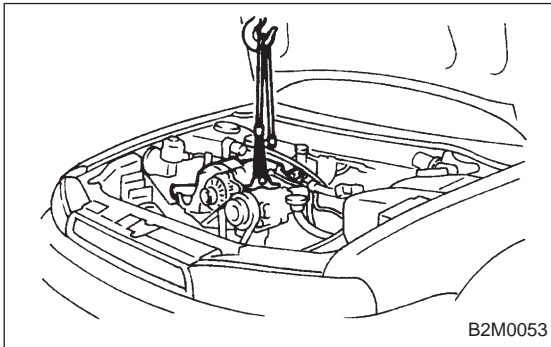

10) Lower the vehicle.

**CAUTION:**

**At this time, lower lifting device and release steel cables.**

11) Remove lifting device and steel cables.

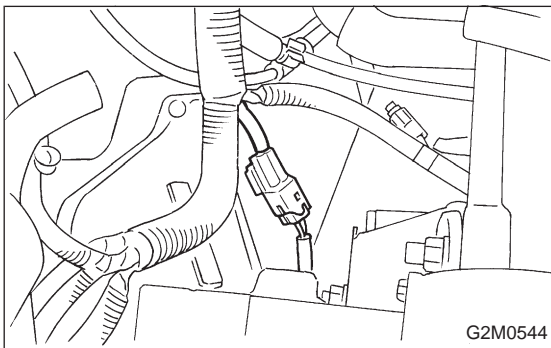

12) Connect connector to front oxygen sensor.

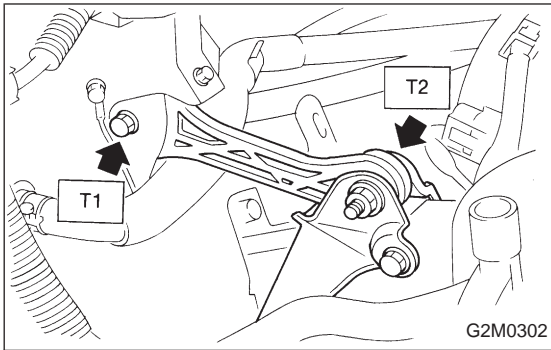

13) Install pitching stopper.

**Tightening torque:**

**T1:  $49 \pm 5$  N·m (5.0  $\pm$  0.5 kg-m, 36.2  $\pm$  3.6 ft-lb)**

**T2:  $57 \pm 10$  N·m (5.8  $\pm$  1.0 kg-m, 42  $\pm$  7 ft-lb)**

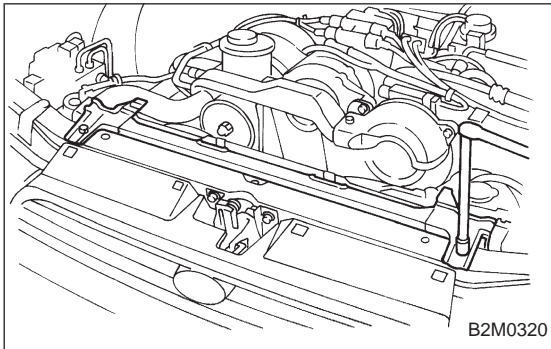

14) Install radiator upper brackets.

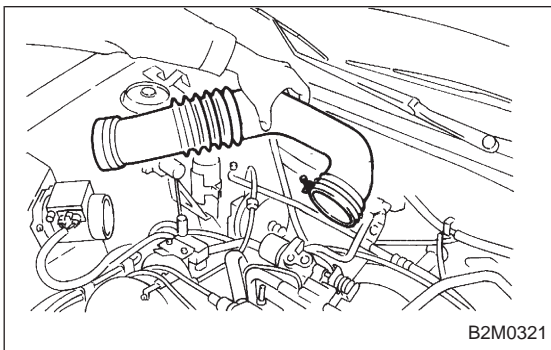

15) Install air intake duct.

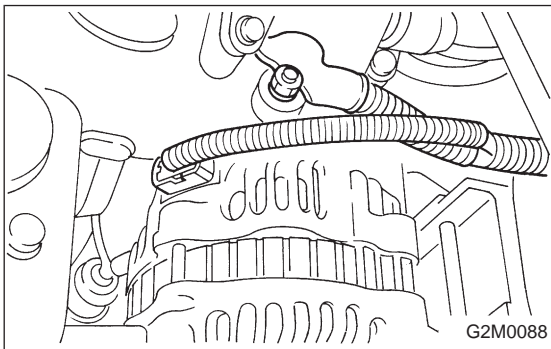

### 3. Oil Pressure Switch

#### A: REMOVAL

1) Remove alternator from bracket.

(1) Disconnect connector and terminal from generator.

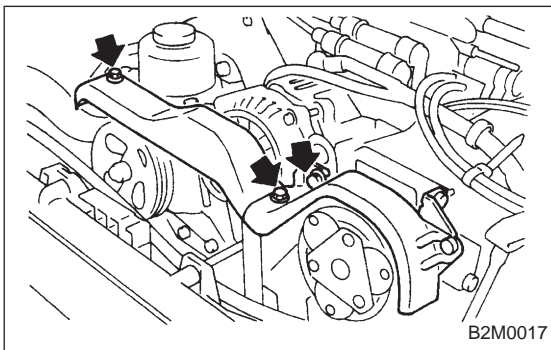

(2) Remove V-belt cover.

(3) Loosen lock bolt and slider bolt, and remove front side V-belt.

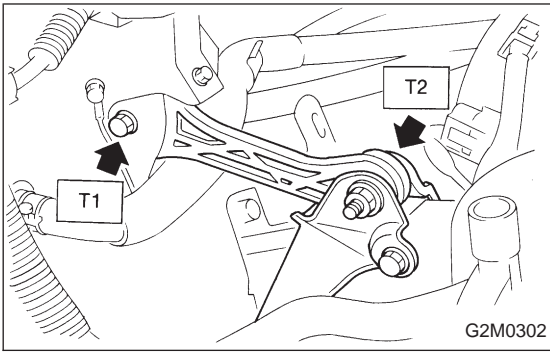

13) Install pitching stopper.

**Tightening torque:**

**T1:  $49 \pm 5$  N·m (5.0 ± 0.5 kg-m, 36.2 ± 3.6 ft-lb)**

**T2:  $57 \pm 10$  N·m (5.8 ± 1.0 kg-m, 42 ± 7 ft-lb)**

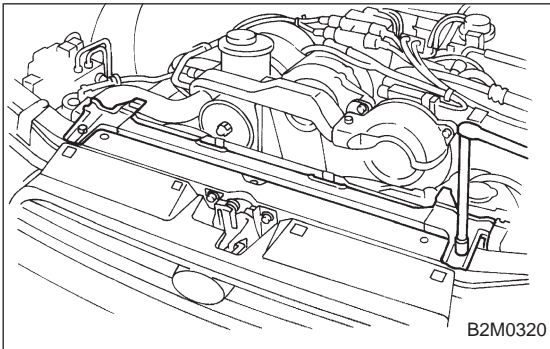

14) Install radiator upper brackets.

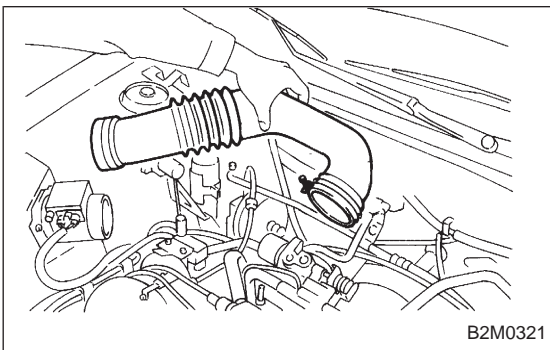

15) Install air intake duct.

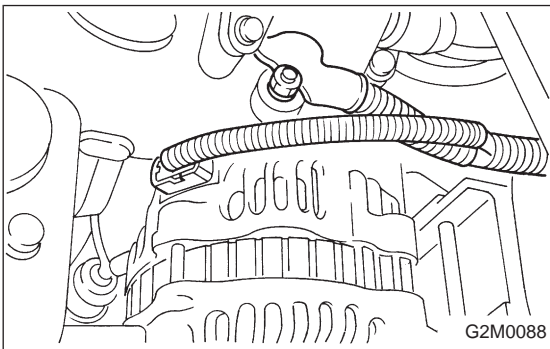

### 3. Oil Pressure Switch

#### A: REMOVAL

1) Remove alternator from bracket.

(1) Disconnect connector and terminal from generator.

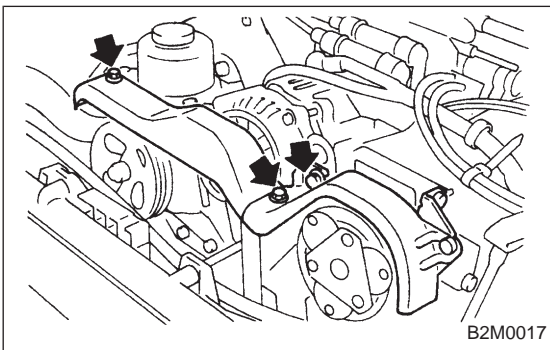

(2) Remove V-belt cover.

(3) Loosen lock bolt and slider bolt, and remove front side V-belt.

## 3. Oil Pressure Switch

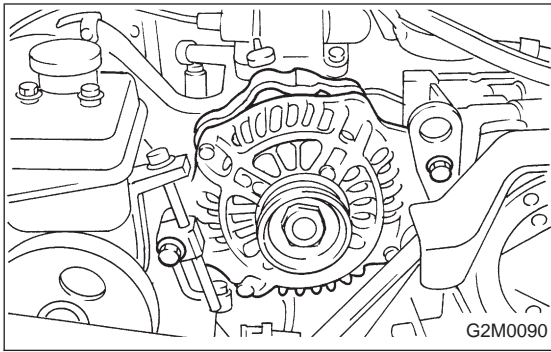

(4) Remove bolts which install generator on bracket.

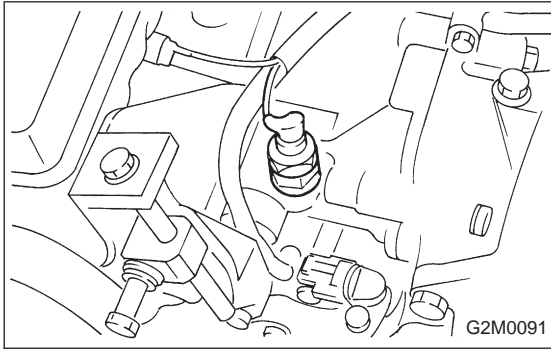

- 2) Disconnect terminal from oil pressure switch.
- 3) Remove oil pressure switch.

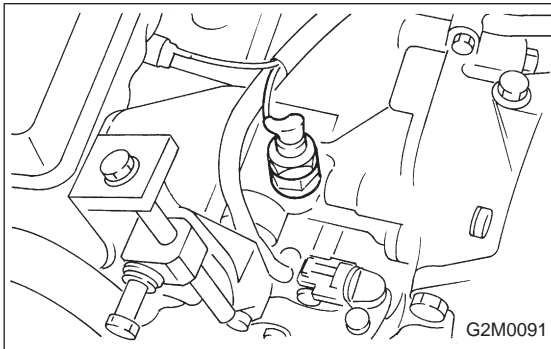
**B: INSTALLATION**

- 1) Install oil pressure switch onto engine block.

**Tightening torque:**

**$25 \pm 3 \text{ N}\cdot\text{m}$  ( $2.5 \pm 0.3 \text{ kg}\cdot\text{m}$ ,  $18.1 \pm 2.2 \text{ ft}\cdot\text{lb}$ )**

- 2) Connect terminal of oil pressure switch.

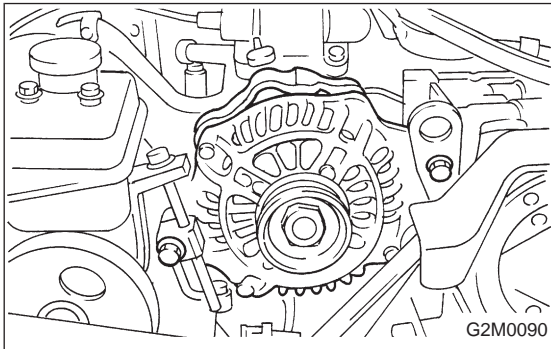

- 3) Install generator on bracket and temporary tighten installing bolts.

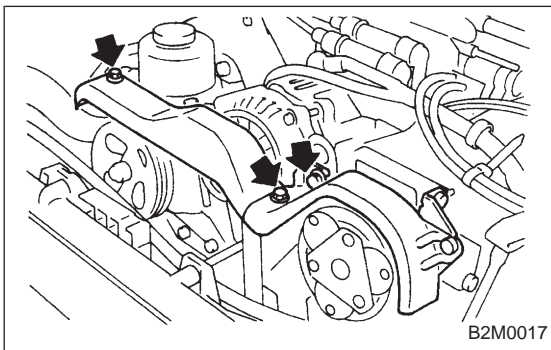

- 4) Install front side V-belt and adjust it.  
<Ref. to 1-5 [01A0].>
- 5) Install V-belt cover.

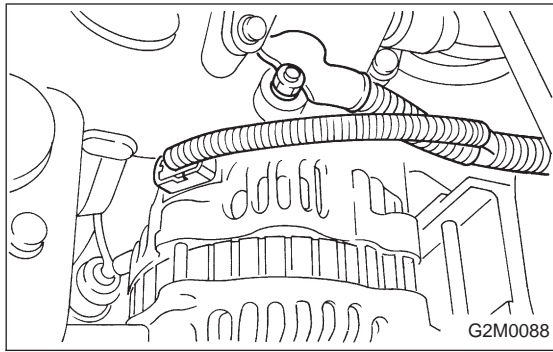

6) Connect connector and terminal to generator.

## 1. Engine Lubrication System

Before troubleshooting, make sure that the engine oil level is correct and no oil leakage exists.

Trouble	Possible cause		Corrective action
1. Warning light remains on.	1) Oil pressure switch failure	Cracked diaphragm or oil leakage within switch	Replace.
		Broken spring or seized contacts	Replace.
	2) Low oil pressure	Clogged oil filter	Replace.
		Malfunction of oil by-pass valve of oil filter	Clean or replace.
		Malfunction of oil relief valve of oil pump	Clean or replace.
		Clogged oil passage	Clean.
		Excessive tip clearance and side clearance of oil pump rotor and gear	Replace.
	3) No oil pressure	Clogged oil strainer or broken pipe	Clean or replace.
		Insufficient engine oil	Replenish.
Broken pipe of oil strainer		Replace.	
2. Warning light does not go on.	Stuck oil pump rotor		Replace.
	1) Burn-out bulb		Replace.
	2) Poor contact of switch contact points		Replace.
3. Warning light flickers momentarily.	3) Disconnection of wiring		Repair.
	1) Poor contact at terminals		Repair.
	2) Defective wiring harness		Repair.
	3) Low oil pressure		Check for the same possible causes as listed in 1.—2)



## 1. Engine Cooling System

## A: SPECIFICATIONS

Cooling system		Electric fan + Forced engine coolant circulation system	
Total engine coolant capacity		ℓ (US qt, Imp qt)	
		Approx. 6.1 (6.4, 5.4)	
Engine coolant pump	Type	Centrifugal impeller type	
	Discharge performance I	Discharge	20 ℓ (5.3 US gal, 4.4 Imp gal)/min.
		Pump speed—total engine coolant head	760 rpm — 0.3 mAq (1.0 ftAq)
		Engine coolant temperature	85°C (185°F)
	Discharge performance II	Discharge	100 ℓ (26.4 US gal, 22.0 Imp gal)/min.
		Pump speed—total engine coolant head	3,000 rpm — 5.0 mAq (16.4 ftAq)
		Engine coolant temperature	85°C (185°F)
	Discharge performance III	Discharge	200 ℓ (52.8 US gal, 44.0 Imp gal)/min.
		Pump speed—total engine coolant head	6,000 rpm — 23.0 mAq (75.5 ftAq)
		Engine coolant temperature	85°C (185°F)
	Impeller diameter		76 mm (2.99 in)
Number of impeller vanes		8	
Pump pulley diameter		60 mm (2.36 in)	
Thermostat	Type	Wax pellet type	
	Starts to open	76 — 80°C (169 — 176°F)	
	Fully opened	91°C (196°F)	
	Valve lift	9.0 mm (0.354 in) or more	
	Valve bore	35 mm (1.38 in)	
Radiator fan	Motor	120 W	
	Fan diameter x Blade	320 mm (12.60 in) x 5	
Radiator	Type	Cross flow, pressure type	
	Core dimensions	670 x 361 x 16 mm (26.38 x 14.21 x 0.63 in)	
	Pressure range in which cap valve is open	Above: 88±10 kPa (0.9±0.1 kg/cm <sup>2</sup> , 12.8±1.4 psi) Below: -4.9 to -9.8 kPa (-0.05 to -0.1 kg/cm <sup>2</sup> , -0.7 to -1.4 psi)	
	Fins	Corrugated fin type	
Reservoir tank	Capacity	0.5 ℓ (0.5 US qt, 0.4 Imp qt)	

## B: SERVICE DATA

Engine coolant pump	Clearance between impeller and case	Standard	0.5 — 0.7 mm (0.020 — 0.028 in)
		Limit	1.0 mm (0.039 in)
	“Thrust” runout of impeller end		0.5 mm (0.020 in)

1. Engine Coolant Pump

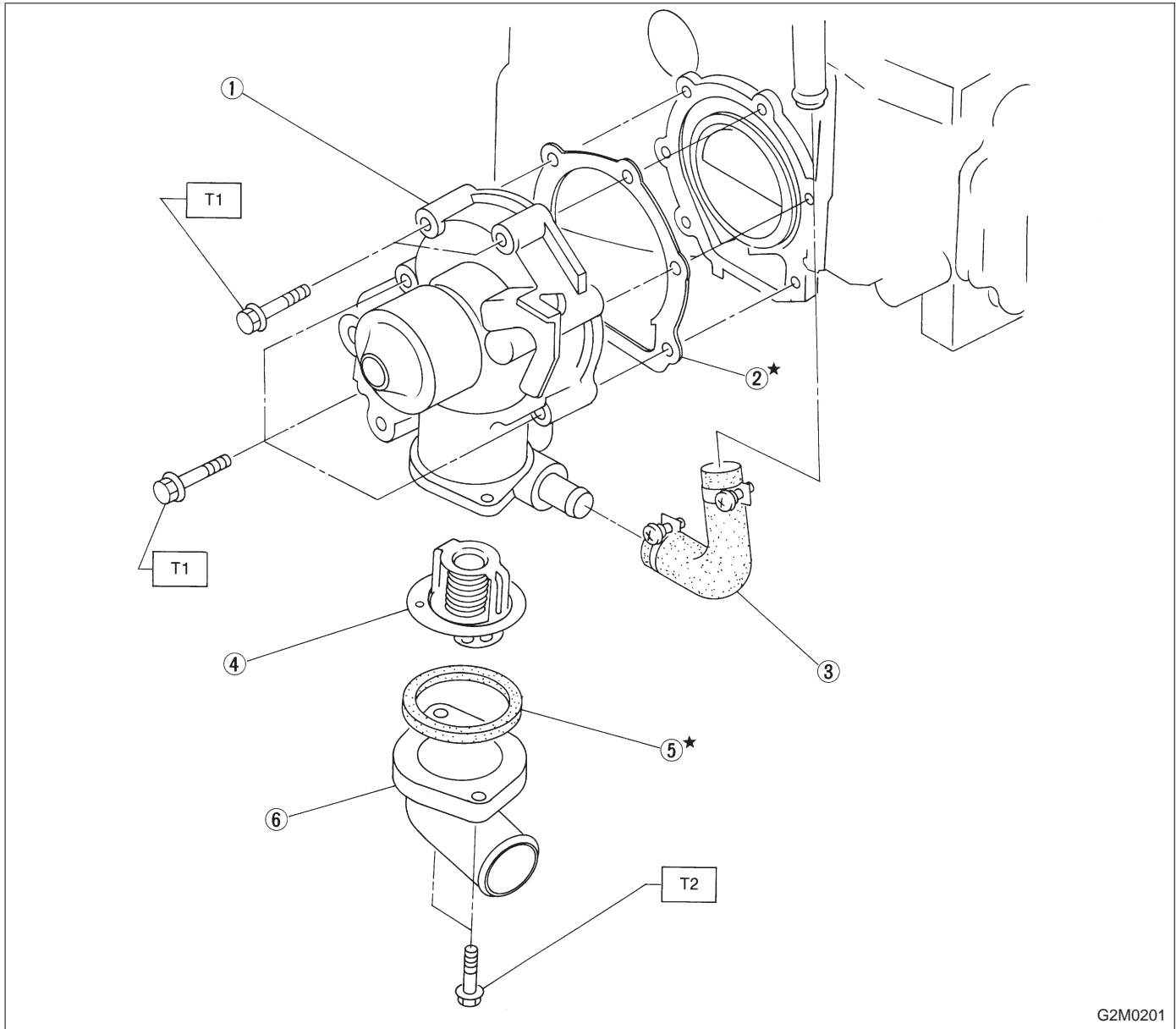

- ① Engine coolant pump ASSY
- ② Gasket
- ③ Heater hose
- ④ Thermostat
- ⑤ Gasket
- ⑥ Thermostat case

**Tightening torque: N·m (kg·m, ft·lb)**

T1: First  $10^{+4}_{-0}$  (1.0<sup>+0.4</sup>, 7.2<sup>+2.9</sup>)  
 Second  $10^{+4}_{-0}$  (1.0<sup>+0.4</sup>, 7.2<sup>+2.9</sup>)

T2:  $6.4 \pm 0.5$  (0.65 $\pm$ 0.05, 4.7 $\pm$ 0.4)

2. Radiator and Radiator Fan

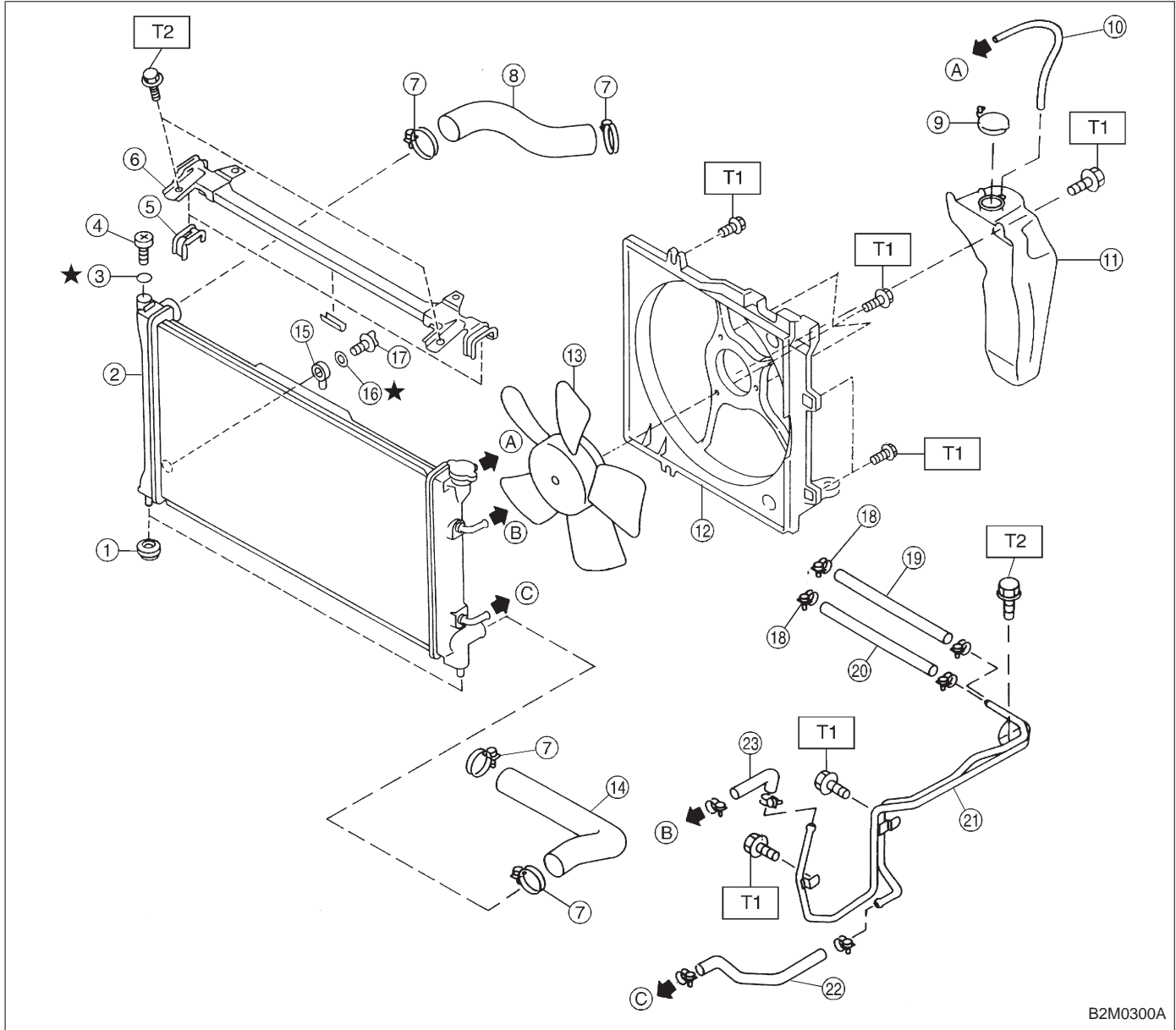

B2M0300A

- ① Radiator lower cushion
- ② Radiator
- ③ O-ring
- ④ Air vent plug
- ⑤ Radiator upper cushion
- ⑥ Radiator upper bracket
- ⑦ Clamp
- ⑧ Radiator inlet hose
- ⑨ Engine coolant reservoir tank cap
- ⑩ Over flow hose
- ⑪ Engine coolant reservoir tank
- ⑫ Shroud
- ⑬ Radiator main fan motor ASSY
- ⑭ Radiator outlet hose

- ⑮ Radiator drain pipe
- ⑯ Gasket
- ⑰ Radiator drain plug
- ⑱ ATF hose clamp
- ⑲ ATF inlet hose A
- ⑳ ATF outlet hose A
- ㉑ ATF pipe
- ㉒ ATF outlet hose B
- ㉓ ATF inlet hose B

**Tightening torque: N·m (kg·m, ft·lb)**  
**T1: 6.9±1.5 (0.7±0.15, 5.1±1.1)**  
**T2: 12±3 (1.2±0.3, 8.7±2.2)**

3. Engine Coolant Pipe

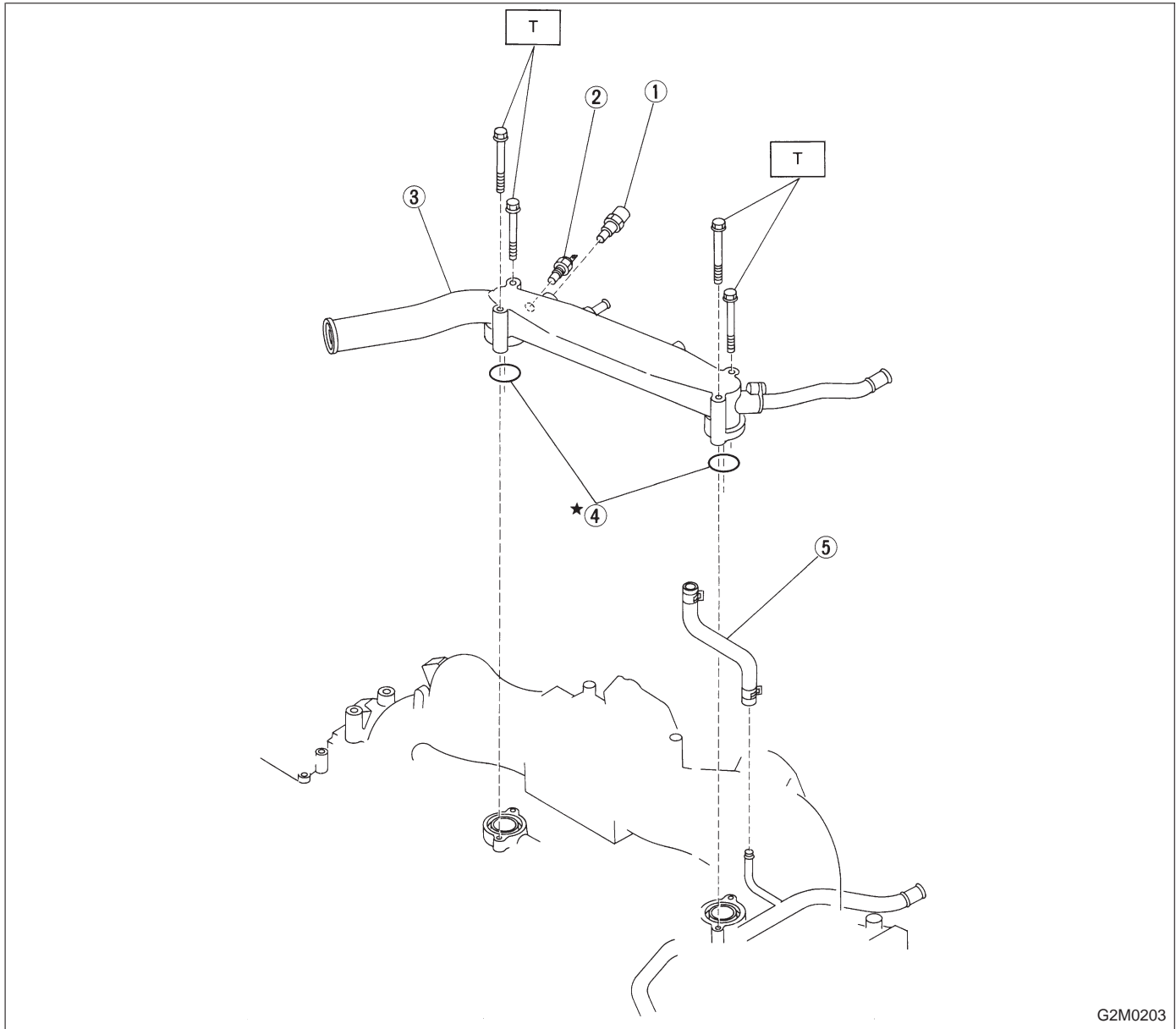

G2M0203

- ① Engine coolant temperature sensor
- ② Engine coolant temperature gauge
- ③ Engine coolant pipe
- ④ O-ring
- ⑤ By-pass hose

**Tightening torque: N·m (kg·m, ft·lb)**  
**T: 6.4±0.5 (0.65±0.05, 4.7±0.4)**

## 1. On-Car Service

### A: DRAINING OF ENGINE COOLANT

1) Lift-up the vehicle.

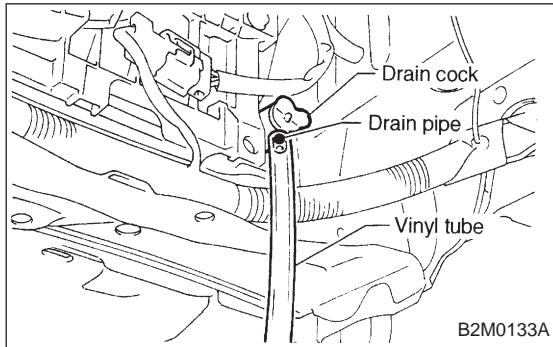

2) Fit vinyl tube to drain pipe.

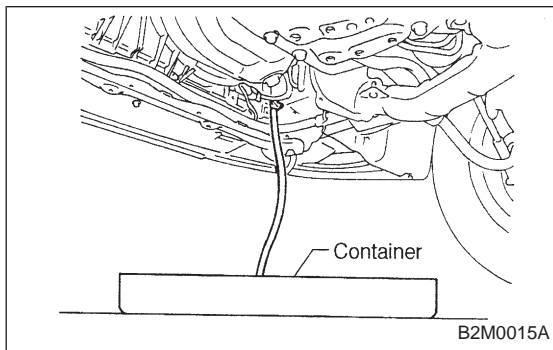

3) Loosen drain cock to drain engine coolant into container.

**NOTE:**

Remove radiator cap so that engine coolant will drain faster.

### B: FILLING OF ENGINE COOLANT

1) Remove air vent plug from radiator.

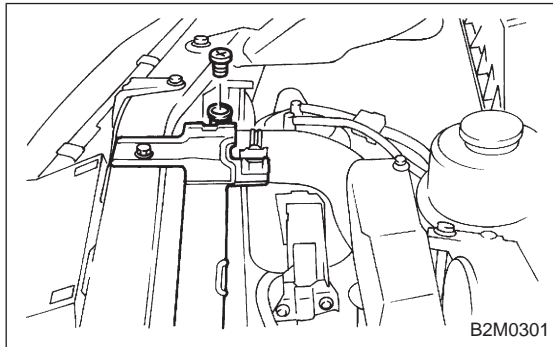

2) Fill engine coolant into radiator up to filler neck position.

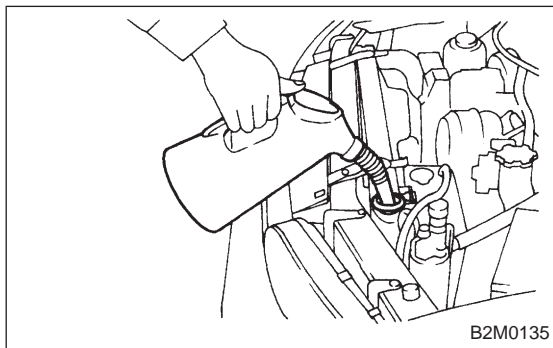

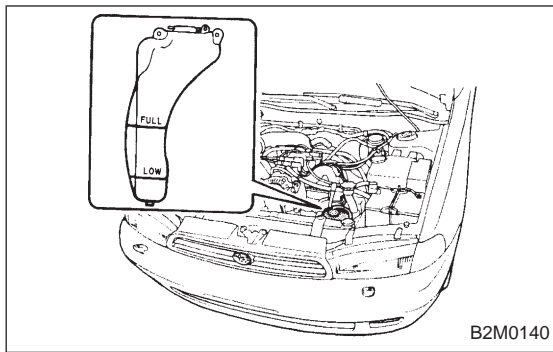

B2M0140

3) Fill engine coolant into reservoir tank up to upper level.

4) Attach radiator cap and reservoir tank cap properly.

5) Install air vent plug.

6) Warm-up engine completely for more than five minutes at 2,000 to 3,000 rpm.

7) Stop engine and wait until temperature drops to a safe level.

8) If engine coolant level drops in radiator, add engine coolant to filler neck position.

9) If engine coolant level drops from upper level of reservoir tank, add engine coolant to upper level.

10) Attach radiator cap and reservoir tank cap properly.

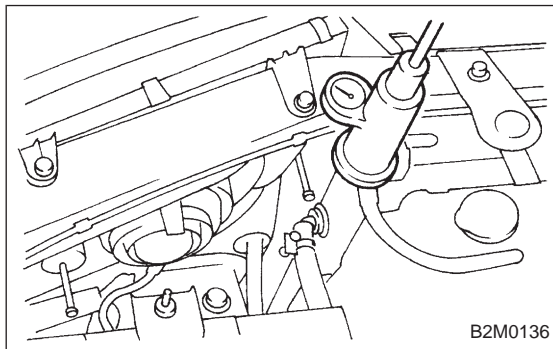

B2M0136

### C: CHECKING OF COOLING SYSTEM

1) Remove radiator cap, top off radiator, and attach tester to radiator in place of cap.

2) Apply a pressure of 157 kPa (1.6 kg/cm<sup>2</sup>, 23 psi) to radiator to check if:

(1) Engine coolant leaks at/around radiator.

(2) Engine coolant leaks at/around hoses or connections.

#### CAUTION:

- Engine should be off.
- Wipe engine coolant from check points in advance.
- Be careful to prevent engine coolant from spurting out when removing tester.
- Be careful also not to deform filler neck of radiator when installing or removing tester.

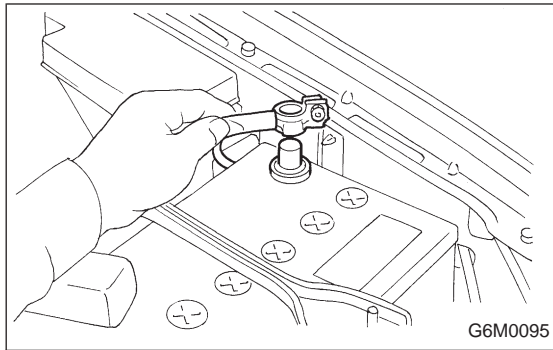

## 2. Engine Coolant Pump

### A: REMOVAL

- 1) Open engine hood.
- 2) Disconnect ground cable from the battery.

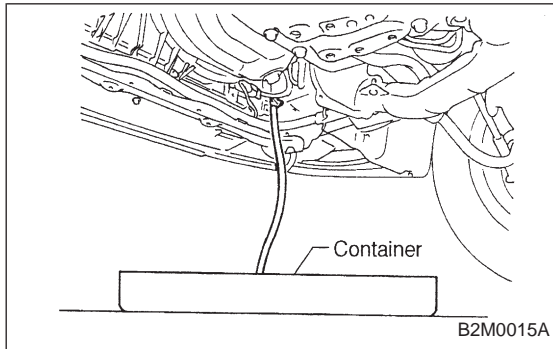

- 3) Drain engine coolant completely.  
<Ref. to 2-5 [W1A0].>

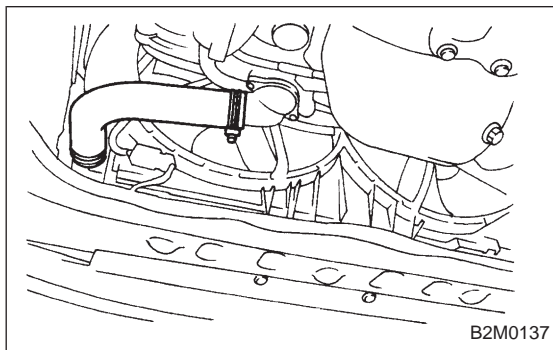

- 4) Disconnect radiator outlet hose from engine coolant pump.

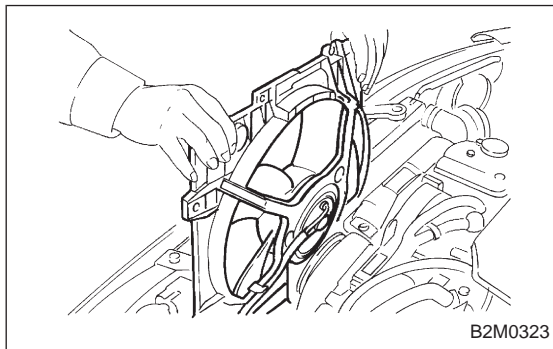

- 5) Remove radiator fan motor assembly.  
<Ref. to 2-5 [W6A0].>

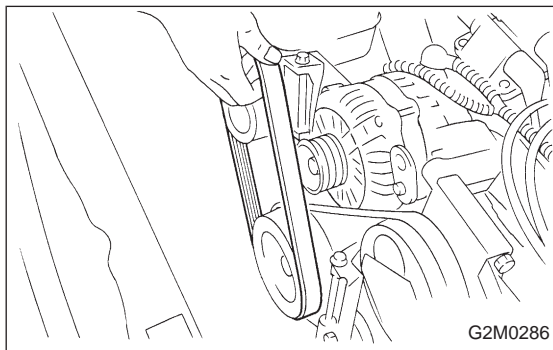

- 6) Remove V-belt(s).  
<Ref. to 1-5 [01B0].>

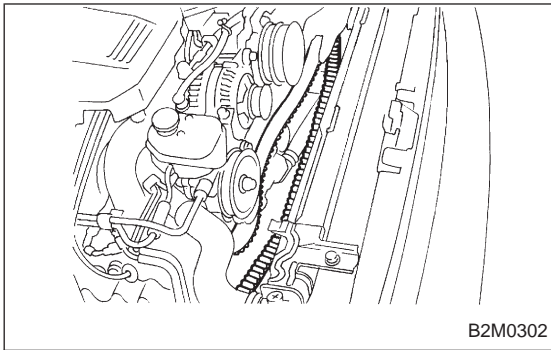

7) Remove timing belt.  
<Ref. to 1-5 [02A0].>

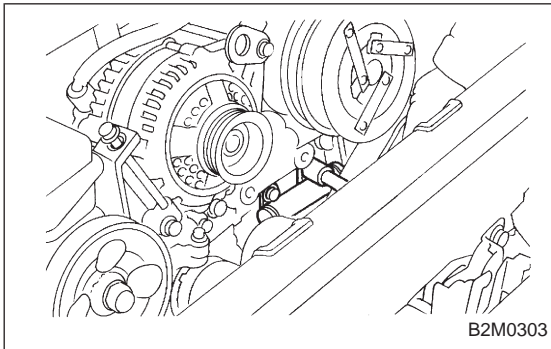

8) Remove belt tension adjuster.

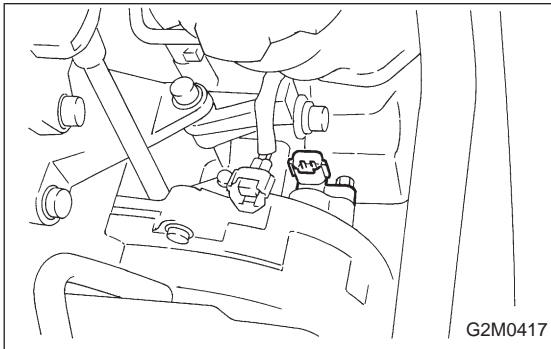

9) Remove camshaft position sensor.  
<Ref. to 2-7 [W10A0].>

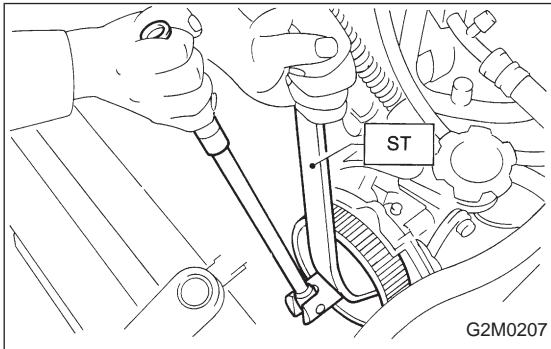

10) Remove left side camshaft pulley by using ST.  
ST 499207100 CAMSHAFT SPROCKET WRENCH

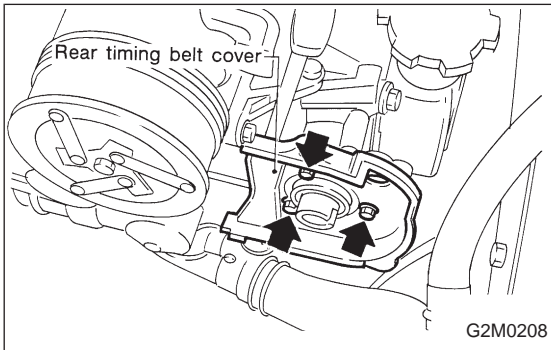

11) Remove left side rear timing belt cover.



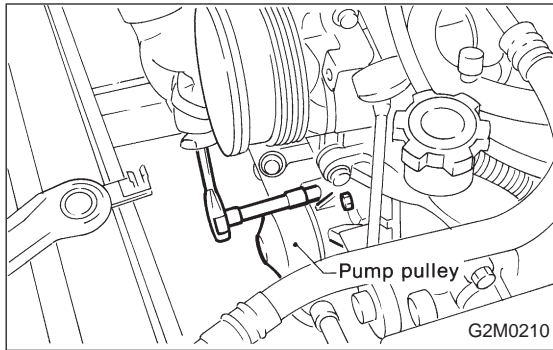

- 12) Remove tensioner bracket.
- 13) Disconnect heater hose from engine coolant pump.
- 14) Remove engine coolant pump.

## B: INSPECTION

- 1) Check engine coolant pump bearing for smooth rotation.
- 2) Check engine coolant pump pulley for abnormalities.

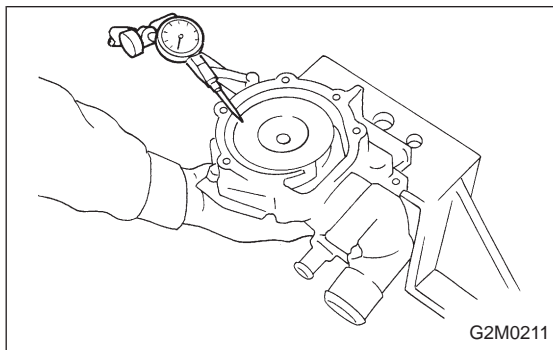

- 3) Using a dial gauge, measure impeller runout in thrust direction while rotating the pulley.

**“Thrust” runout limit:**  
**0.5 mm (0.020 in)**

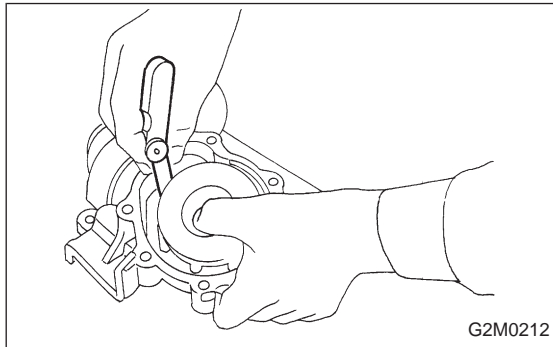

- 4) Check clearance between impeller and pump case.

**Clearance between impeller and pump case:**

**Standard**

**0.5 — 0.7 mm (0.020 — 0.028 in)**

**Limit**

**1.0 mm (0.039 in)**

- 5) After engine coolant pump installation, check pulley shaft for engine coolant leaks. If leaks are noted, replace engine coolant pump assembly.

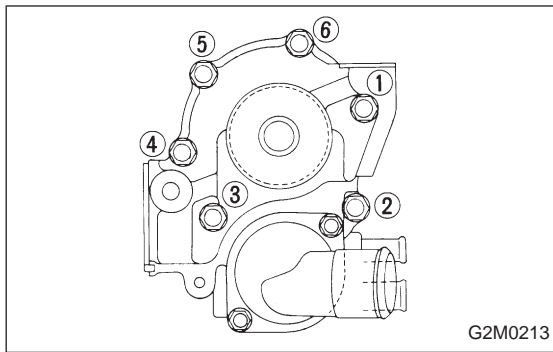

G2M0213

**C: INSTALLATION**

Installation is in the reverse order of removal.

**CAUTION:**

- Replace gasket with a new one.
- When installing engine coolant pump, tighten bolts in two stages in numerical sequence as shown in figure.

**Tightening torque:**

$$10_{-0}^{+4} \text{ N}\cdot\text{m} \left( 1.0_{-0}^{+0.4} \text{ kg}\cdot\text{m}, 7.2_{-0}^{+2.9} \text{ ft}\cdot\text{lb} \right)$$

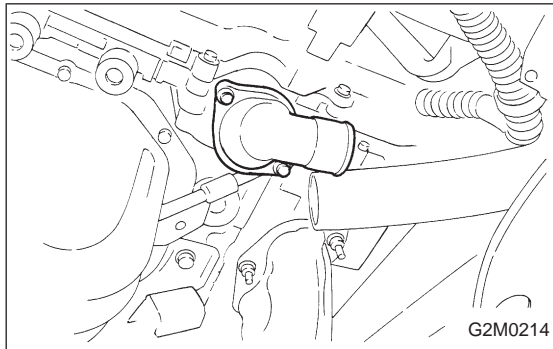

G2M0214

**3. Thermostat**

**A: REMOVAL AND INSTALLATION**

- 1) Drain engine coolant. Set container under the vehicle, and remove drain cock from radiator.
- 2) Disconnect radiator outlet hose from thermostat cover.
- 3) Remove thermostat cover and gasket, and pull out the thermostat.

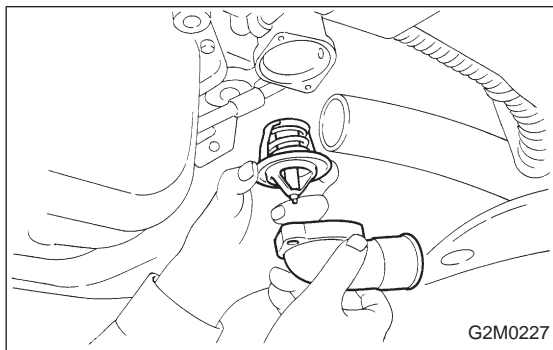

G2M0227

- 4) Install the thermostat in the intake manifold, and install the thermostat cover together with a gasket.

**CAUTION:**

- When reinstalling the thermostat, use a new gasket.
- The thermostat must be installed with the jiggle pin upward.
- In this time, set the jiggle pin of thermostat for front side.

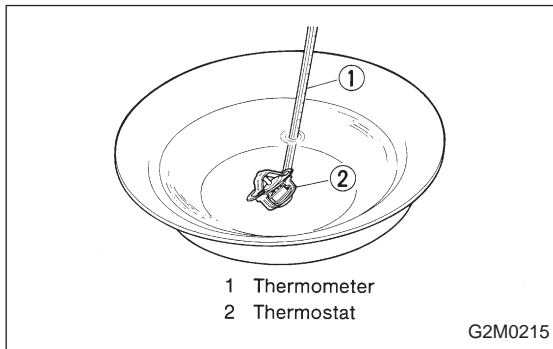

1 Thermometer  
2 Thermostat

G2M0215

**B: INSPECTION**

Replace the thermostat if the valve does not close completely at an ambient temperature or if the following test shows unsatisfactory results.

Immerse the thermostat and a thermometer in water. Raise water temperature gradually, and measure the temperature and valve lift when the valve begins to open and when the valve is fully opened. During the test, agitate the water for even temperature distribution. The measurement should be to the specification.

**Starts to open:**

$$76.0 - 80.0^{\circ}\text{C} \left( 169 - 176^{\circ}\text{F} \right)$$

**Fully opens:**

$$91^{\circ}\text{C} \left( 196^{\circ}\text{F} \right)$$

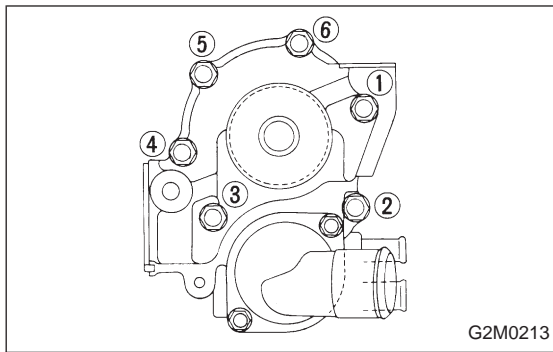

G2M0213

**C: INSTALLATION**

Installation is in the reverse order of removal.

**CAUTION:**

- Replace gasket with a new one.
- When installing engine coolant pump, tighten bolts in two stages in numerical sequence as shown in figure.

**Tightening torque:**

$10_{-0}^{+4} N\cdot m$  ( $1.0_{-0}^{+0.4} kg\cdot m$ ,  $7.2_{-0}^{+2.9} ft\cdot lb$ )

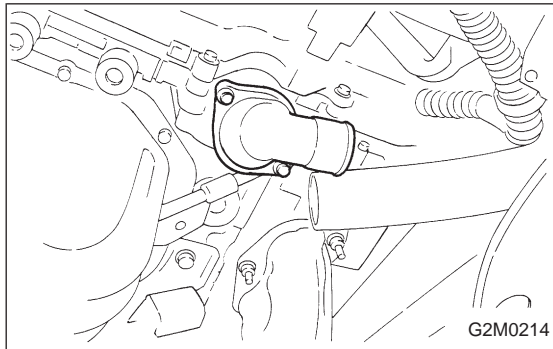

G2M0214

**3. Thermostat**

**A: REMOVAL AND INSTALLATION**

- 1) Drain engine coolant. Set container under the vehicle, and remove drain cock from radiator.
- 2) Disconnect radiator outlet hose from thermostat cover.
- 3) Remove thermostat cover and gasket, and pull out the thermostat.

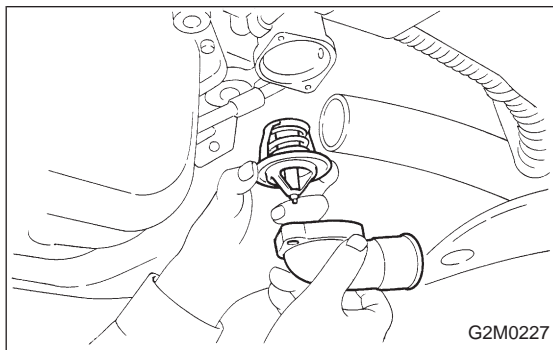

G2M0227

- 4) Install the thermostat in the intake manifold, and install the thermostat cover together with a gasket.

**CAUTION:**

- When reinstalling the thermostat, use a new gasket.
- The thermostat must be installed with the jiggle pin upward.
- In this time, set the jiggle pin of thermostat for front side.

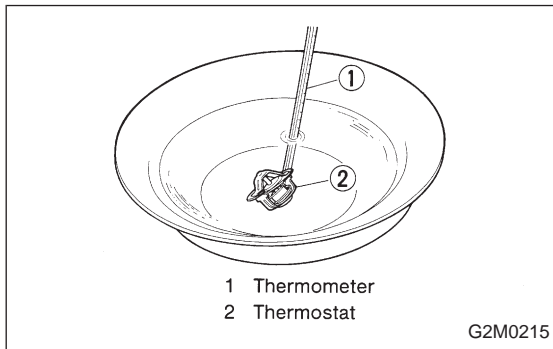

G2M0215

**B: INSPECTION**

Replace the thermostat if the valve does not close completely at an ambient temperature or if the following test shows unsatisfactory results.

Immerse the thermostat and a thermometer in water. Raise water temperature gradually, and measure the temperature and valve lift when the valve begins to open and when the valve is fully opened. During the test, agitate the water for even temperature distribution. The measurement should be to the specification.

**Starts to open:**

$76.0 - 80.0^{\circ}C$  ( $169 - 176^{\circ}F$ )

**Fully opens:**

$91^{\circ}C$  ( $196^{\circ}F$ )

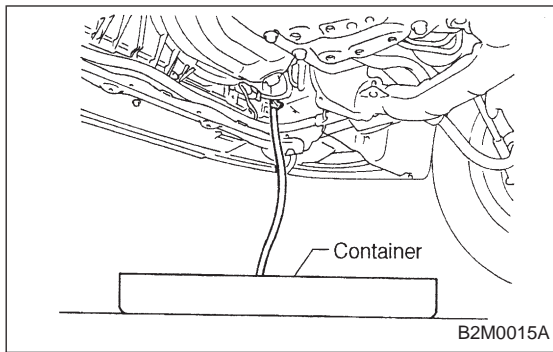

## 4. Radiator

### A: REMOVAL

1) Disconnect battery cables and remove battery from body.

2) Drain engine coolant.

Set container under the vehicle, and remove drain cock from radiator.

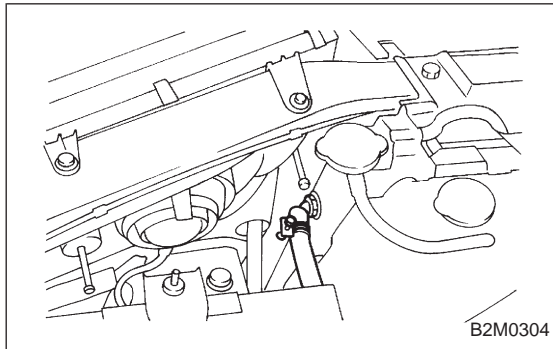

3) Disconnect radiator outlet hose from thermostat cover.

4) Disconnect ATF cooler hoses from radiator. (AT model)

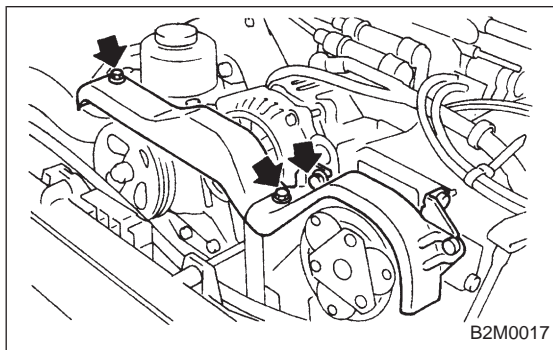

5) Remove V-belt cover.

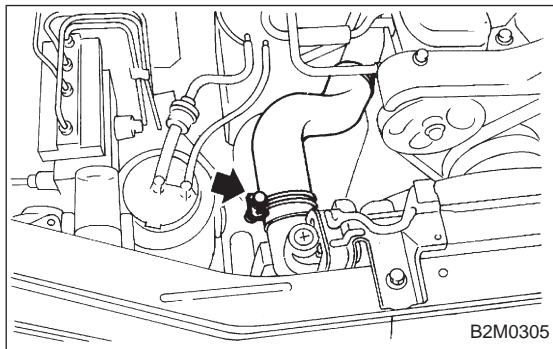

6) Disconnect inlet hose from radiator.

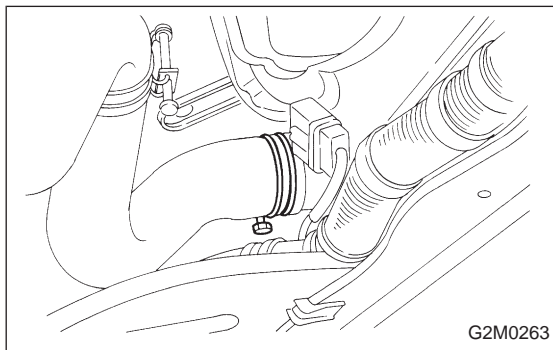

7) Disconnect connectors of radiator main fan and sub fan motor.

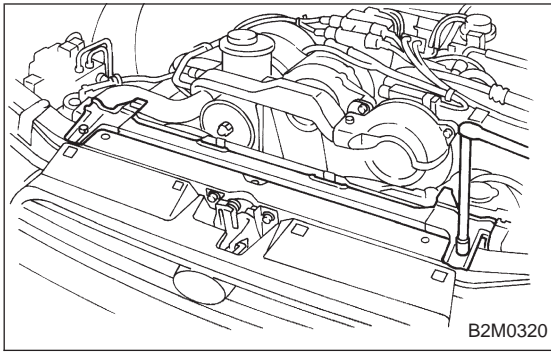

8) Remove radiator upper brackets.

NOTE:

Place left upper radiator bracket between grille and body.

9) While slightly lifting radiator, slide it to left.

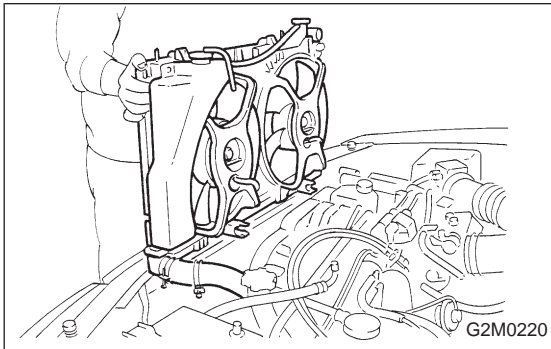

10) Lift radiator up and away from vehicle.

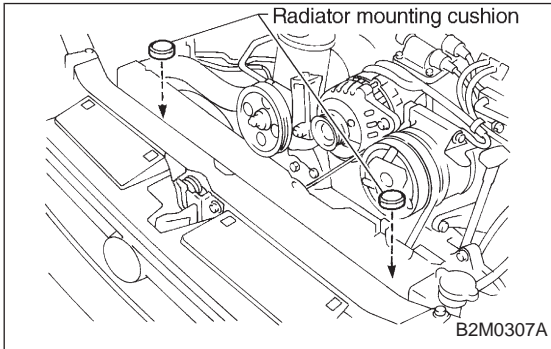

**B: INSTALLATION**

1) Attach radiator mounting cushions to body.

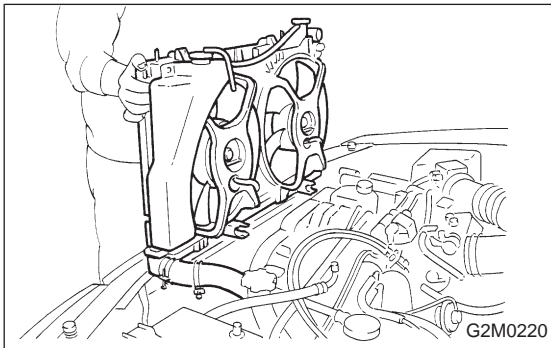

2) Install radiator while fitting radiator pins to cushions.

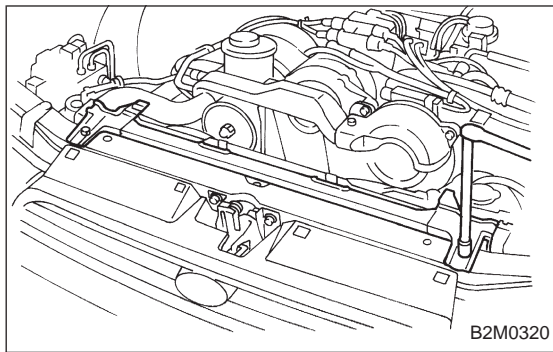

- 3) Install radiator brackets and tighten bolts.
- 4) Connect radiator main fan motor and sub fan motor connectors.

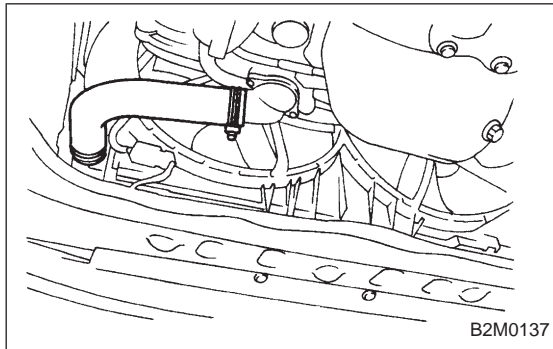

- 5) Connect radiator inlet and outlet hoses.
- 6) Connect ATF cooler hoses. (AT model)

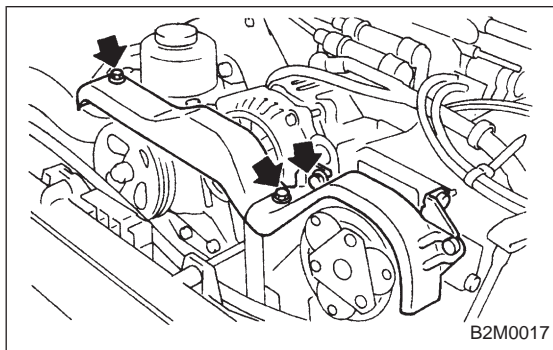

- 7) Install V-belt cover.

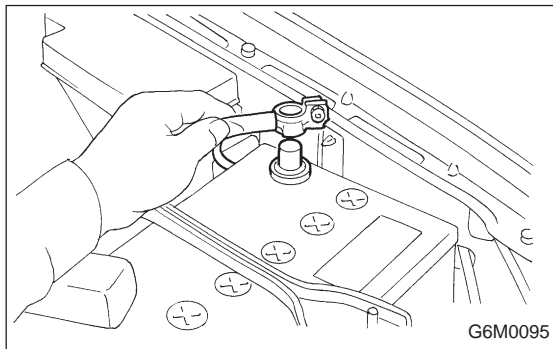

- 8) Connect ground cable to battery terminal.

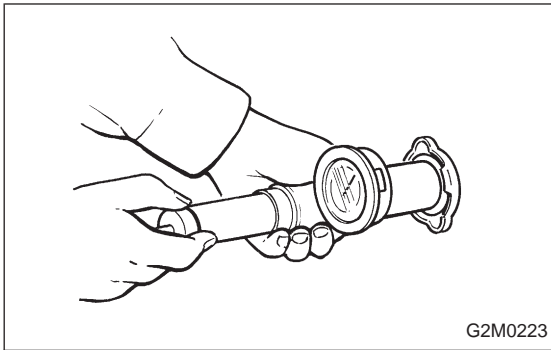

## 5. Radiator Cap

### A: INSPECTION

- 1) Attach radiator cap to tester.
- 2) Increase pressure until tester gauge pointer stops. Radiator cap is functioning properly if it holds the service limit pressure for five to six seconds.

#### **Standard pressure:**

**78 — 98 kPa (0.8 — 1.0 kg/cm<sup>2</sup>, 11 — 14 psi)**

#### **Service limit pressure:**

**69 kPa (0.7 kg/cm<sup>2</sup>, 10 psi)**

### CAUTION:

**Be sure to remove foreign matter and rust from the cap in advance; otherwise, results of pressure test will be incorrect.**

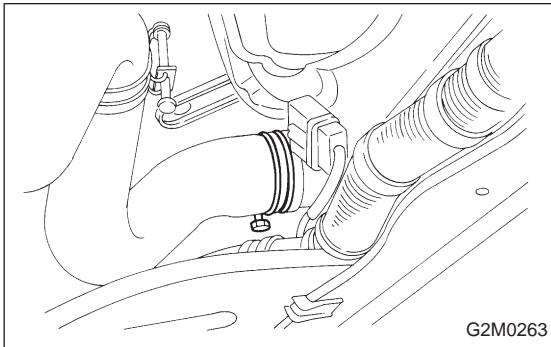

## 6. Radiator Fan and Fan Motor

### A: REMOVAL

- 1) Disconnect ground cable from battery terminal.
- 2) Disconnect connector of fan motor.

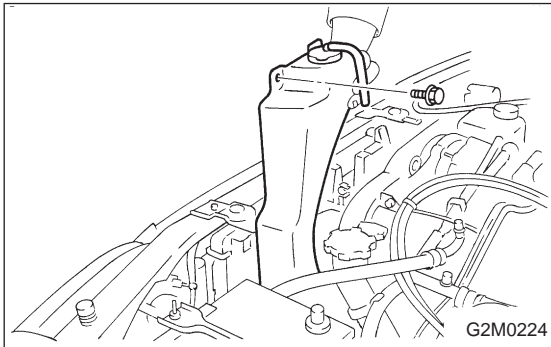

- 3) Remove reservoir tank.

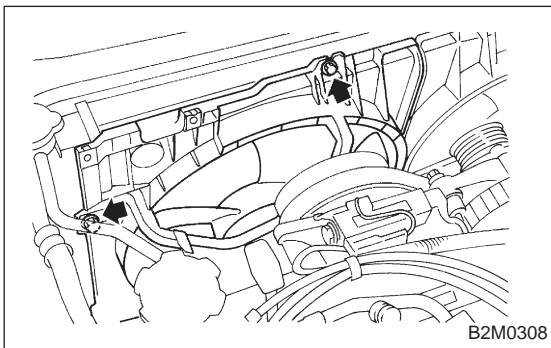

- 4) Remove four bolts holding shroud to radiator.

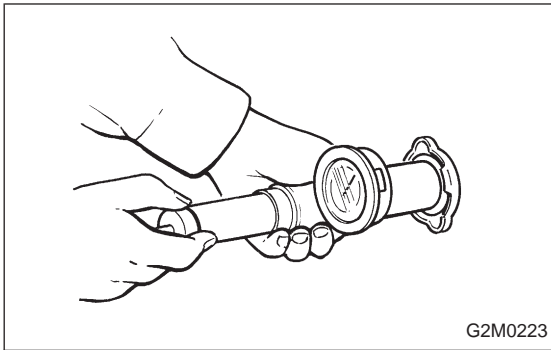

## 5. Radiator Cap

### A: INSPECTION

- 1) Attach radiator cap to tester.
- 2) Increase pressure until tester gauge pointer stops. Radiator cap is functioning properly if it holds the service limit pressure for five to six seconds.

**Standard pressure:**

**78 — 98 kPa (0.8 — 1.0 kg/cm<sup>2</sup>, 11 — 14 psi)**

**Service limit pressure:**

**69 kPa (0.7 kg/cm<sup>2</sup>, 10 psi)**

**CAUTION:**

**Be sure to remove foreign matter and rust from the cap in advance; otherwise, results of pressure test will be incorrect.**

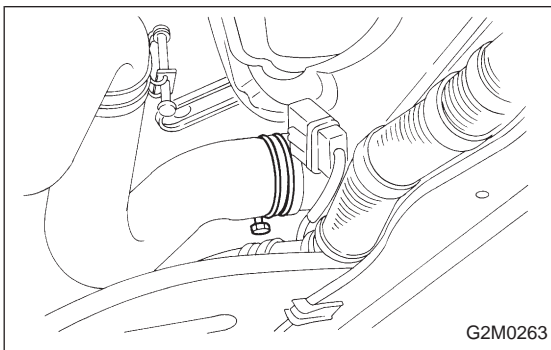

## 6. Radiator Fan and Fan Motor

### A: REMOVAL

- 1) Disconnect ground cable from battery terminal.
- 2) Disconnect connector of fan motor.

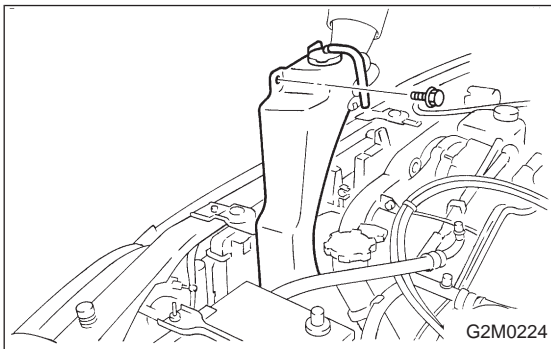

- 3) Remove reservoir tank.

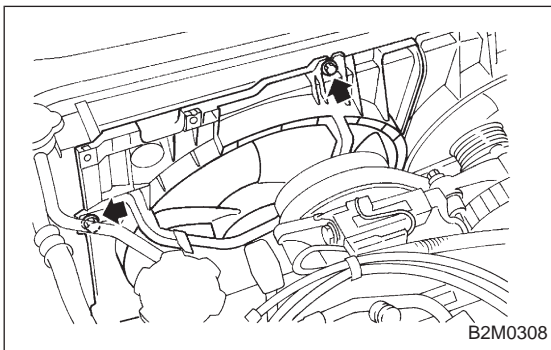

- 4) Remove four bolts holding shroud to radiator.



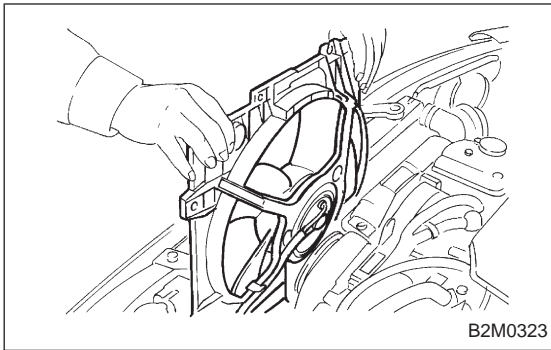

- 5) Remove radiator fan motor assembly.
- 6) Remove fan motor from shroud.

## B: INSTALLATION

Installation is in the reverse order of removal procedures. Do the following:

- 1) Before installing radiator fan motor, apply a coat of sealant to threads and tighten nuts.
- 2) Make sure radiator fan does not come into contact with shroud when installed.
- 3) After installation, make sure there is no unusual noise or vibration when fan is rotated.

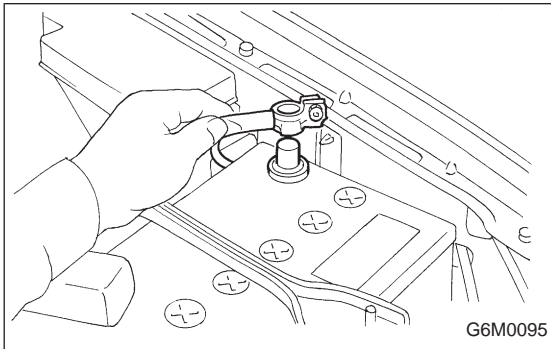

## 7. Engine Coolant Pipe

### A: REMOVAL

- 1) Release fuel pressure.  
<Ref. to 2-8 [W1A0].>
- 2) Disconnect ground cable from the battery.

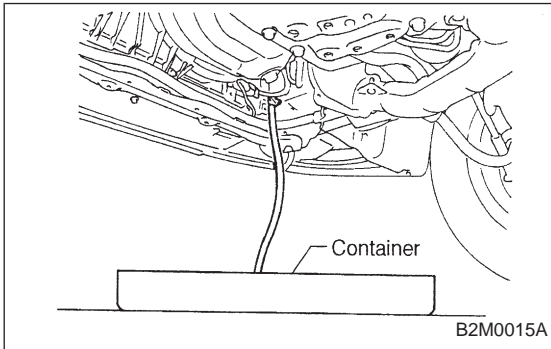

- 3) Drain engine coolant completely.  
<Ref. to 2-5 [W1A0].>

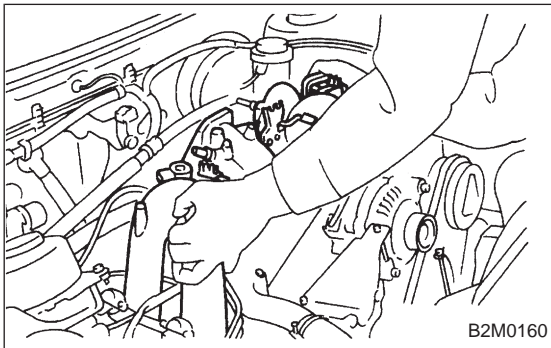

- 4) Remove intake manifold.  
<Ref. to 2-7 [W4A0].>

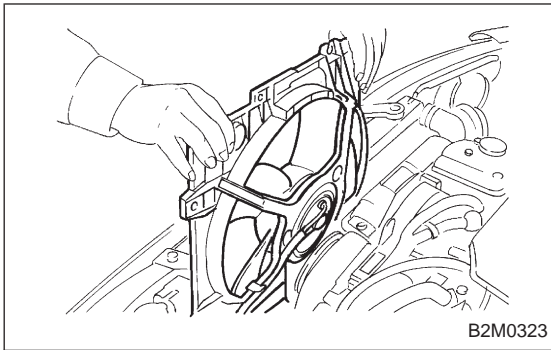

- 5) Remove radiator fan motor assembly.
- 6) Remove fan motor from shroud.

## B: INSTALLATION

Installation is in the reverse order of removal procedures. Do the following:

- 1) Before installing radiator fan motor, apply a coat of sealant to threads and tighten nuts.
- 2) Make sure radiator fan does not come into contact with shroud when installed.
- 3) After installation, make sure there is no unusual noise or vibration when fan is rotated.

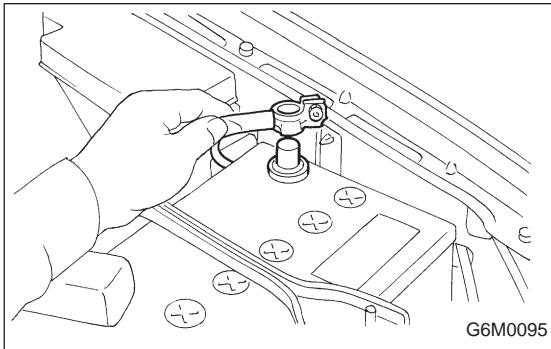

## 7. Engine Coolant Pipe

### A: REMOVAL

- 1) Release fuel pressure.  
<Ref. to 2-8 [W1A0].>
- 2) Disconnect ground cable from the battery.

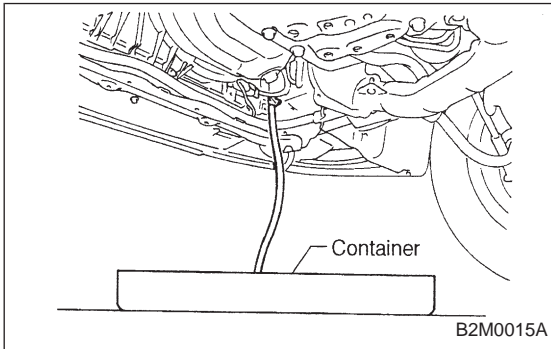

- 3) Drain engine coolant completely.  
<Ref. to 2-5 [W1A0].>

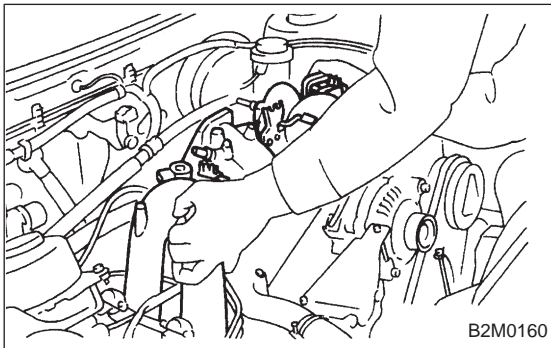

- 4) Remove intake manifold.  
<Ref. to 2-7 [W4A0].>

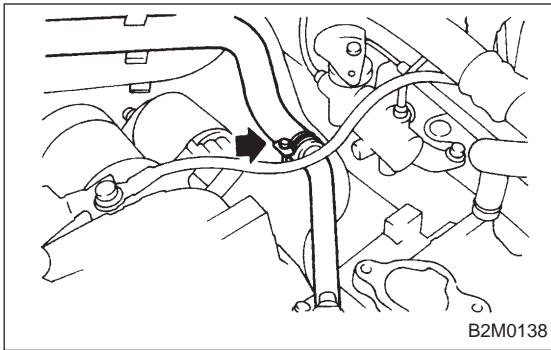

5) Disconnect heater inlet hose.

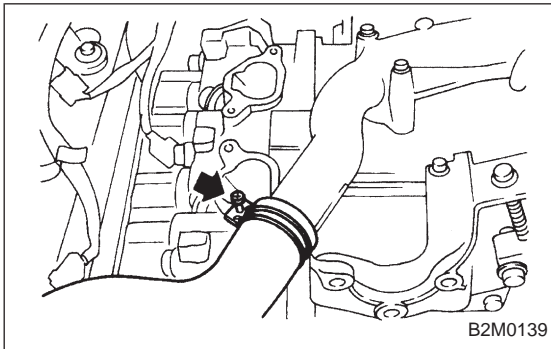

6) Disconnect radiator inlet hose from engine coolant pipe.

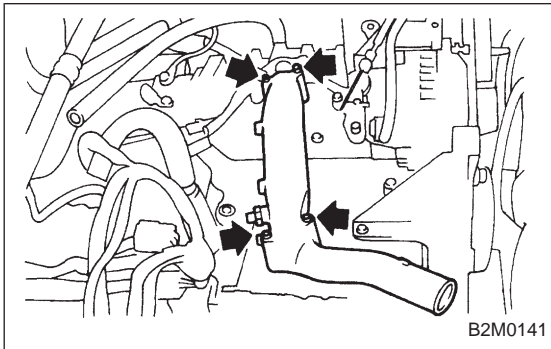

7) Remove bolts which install engine coolant pipe on cylinder block.

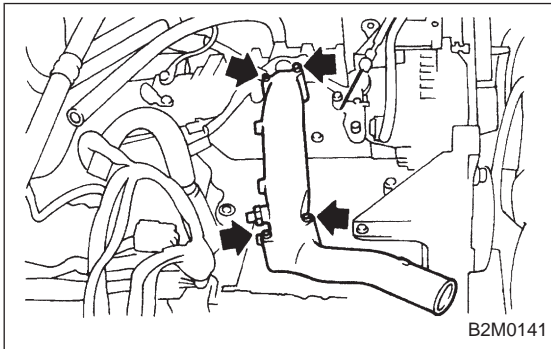

**B: INSTALLATION**

1) Install engine coolant pipe on cylinder block.

**Tightening torque:**

**$6.4 \pm 0.5 \text{ N}\cdot\text{m}$  ( $0.65 \pm 0.05 \text{ kg}\cdot\text{m}$ ,  $4.7 \pm 0.4 \text{ ft}\cdot\text{lb}$ )**

**CAUTION:**

**Use a new O-ring.**

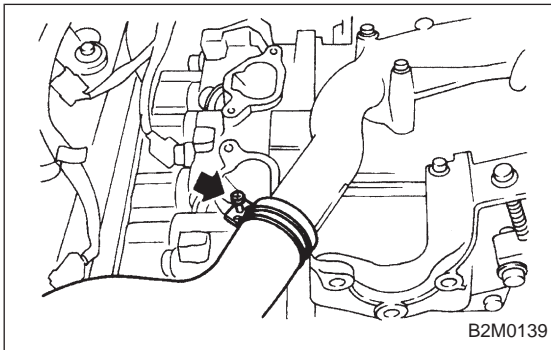

2) Connect radiator inlet hose.

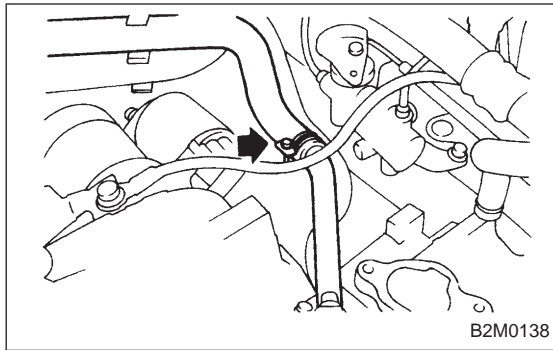

3) Connect heater inlet hose.

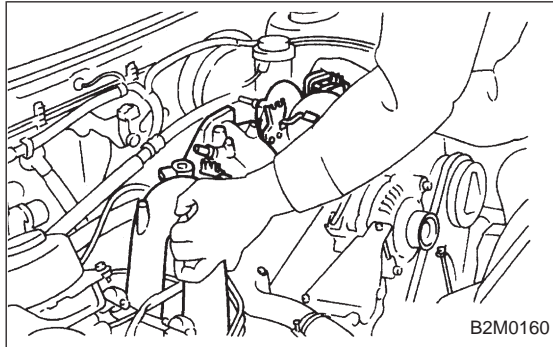

4) Install intake manifold.  
<Ref. to 2-7 [W4D0].>

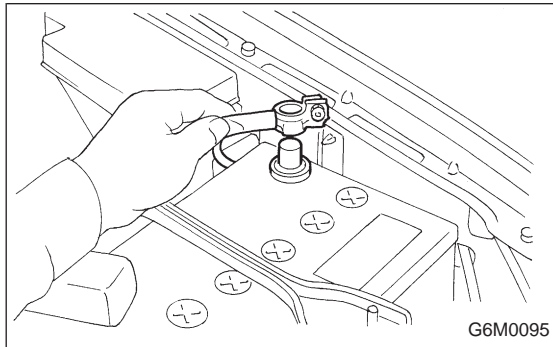

5) Connect ground cable to battery terminal.

## 1. Engine Cooling System

Trouble	Possible cause	Corrective action
Over-heating	a. Insufficient engine coolant	Replenish engine coolant, inspect for leakage, and repair.
	b. Loose timing belt	Repair or replace timing belt tensioner.
	c. Oil on drive belt	Replace.
	d. Malfunction of thermostat	Replace.
	e. Malfunction of engine coolant pump	Replace.
	f. Clogged engine coolant passage	Clean.
	g. Improper ignition timing	Inspect and repair ignition control system. <Ref. to 2-7 On-Board Diagnostics II System.>
	h. Clogged or leaking radiator	Clean or repair, or replace.
	i. Improper engine oil in engine coolant	Replace engine coolant.
	j. Air/fuel mixture ratio too lean	Inspect and repair fuel injection system. <Ref. to 2-7 On-Board Diagnostics II System.>
	k. Excessive back pressure in exhaust system	Clean or replace.
	l. Insufficient clearance between piston and cylinder	Adjust or replace.
	m. Slipping clutch	Repair or replace.
	n. Dragging brake	Adjust.
	o. Improper transmission oil	Replace.
p. Defective thermostat	Replace.	
q. Malfunction of electric fan	Inspect radiator fan relay, engine coolant temperature sensor or radiator motor and replace there.	
Over-cooling	a. Atmospheric temperature extremely low	Partly cover radiator front area.
	b. Defective thermostat	Replace.
Engine coolant leaks.	a. Loosened or damaged connecting units on hoses	Repair or replace.
	b. Leakage from engine coolant pump	Replace.
	c. Leakage from engine coolant pipe	Repair or replace.
	d. Leakage around cylinder head gasket	Retighten cylinder head bolts or replace gasket.
	e. Damaged or cracked cylinder head and crankcase	Repair or replace.
	f. Damaged or cracked thermostat case	Repair or replace.
	g. Leakage from radiator	Repair or replace.
Noise	a. Defective drive belt	Replace.
	b. Defective radiator fan	Replace.
	c. Defective engine coolant pump bearing	Replace engine coolant pump.
	d. Defective engine coolant pump mechanical seal	Replace engine coolant pump.

## 2. Radiator Main Fan

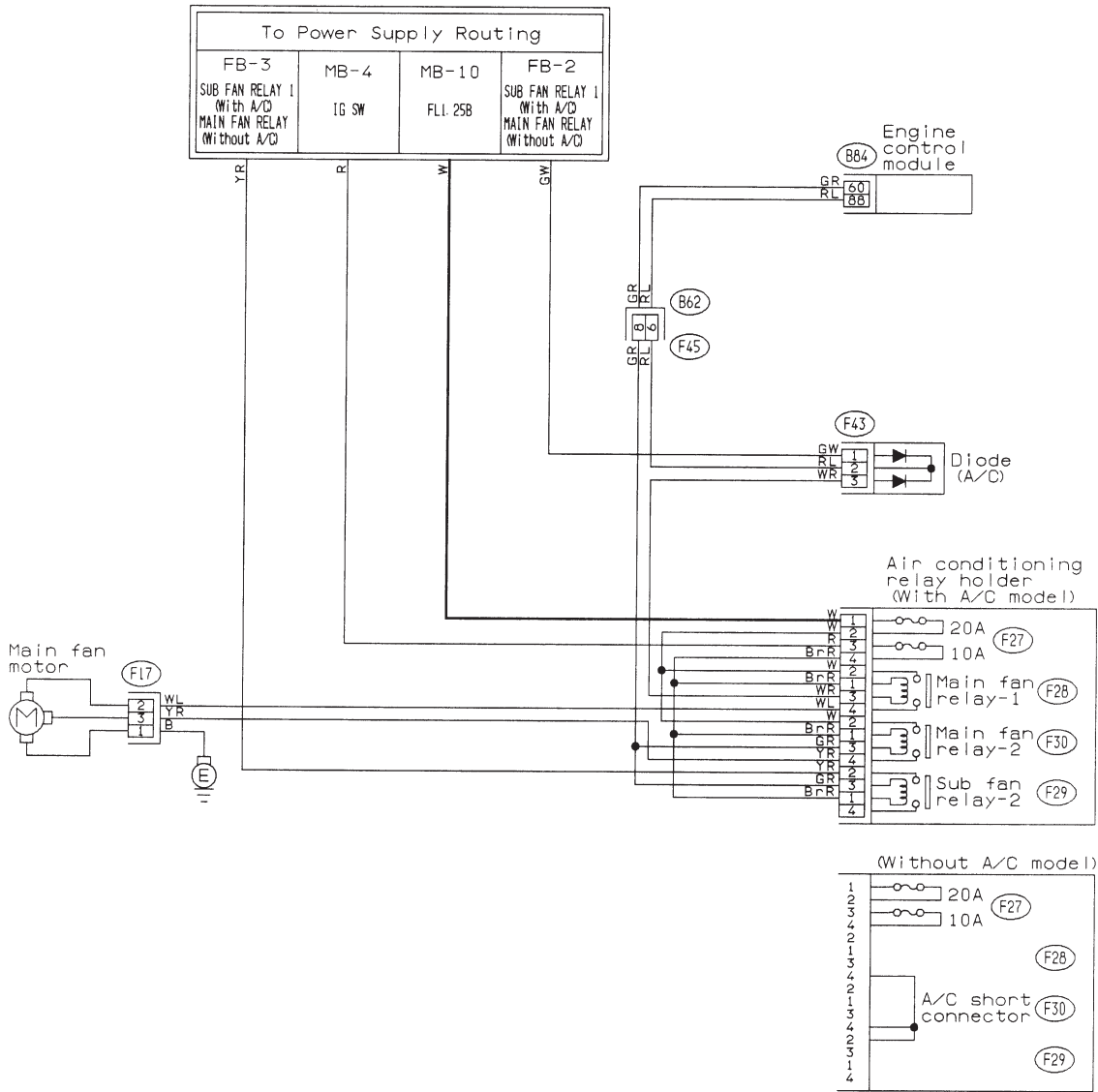

(F43) (Orange)

(F17) (Black)



(F45)

(B84) (Dark gray)

(F27) (F28) (F29) (F30) (F31)



A/C relay holder (Black)

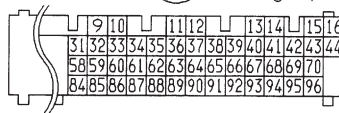

**A: OPERATION (WITHOUT A/C MODEL)**

**CONDITION:**

- Engine coolant temperature is above 95°C (203°F).

**TROUBLE SYMPTOM:**

- Radiator main fan does not operate under the above condition.

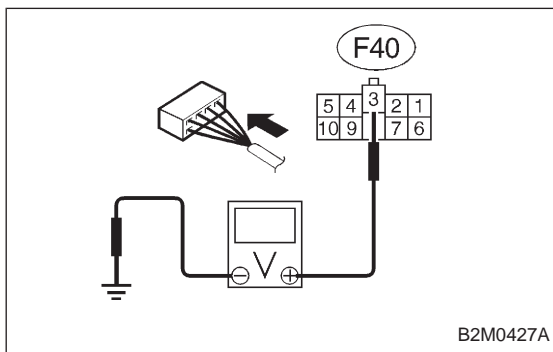
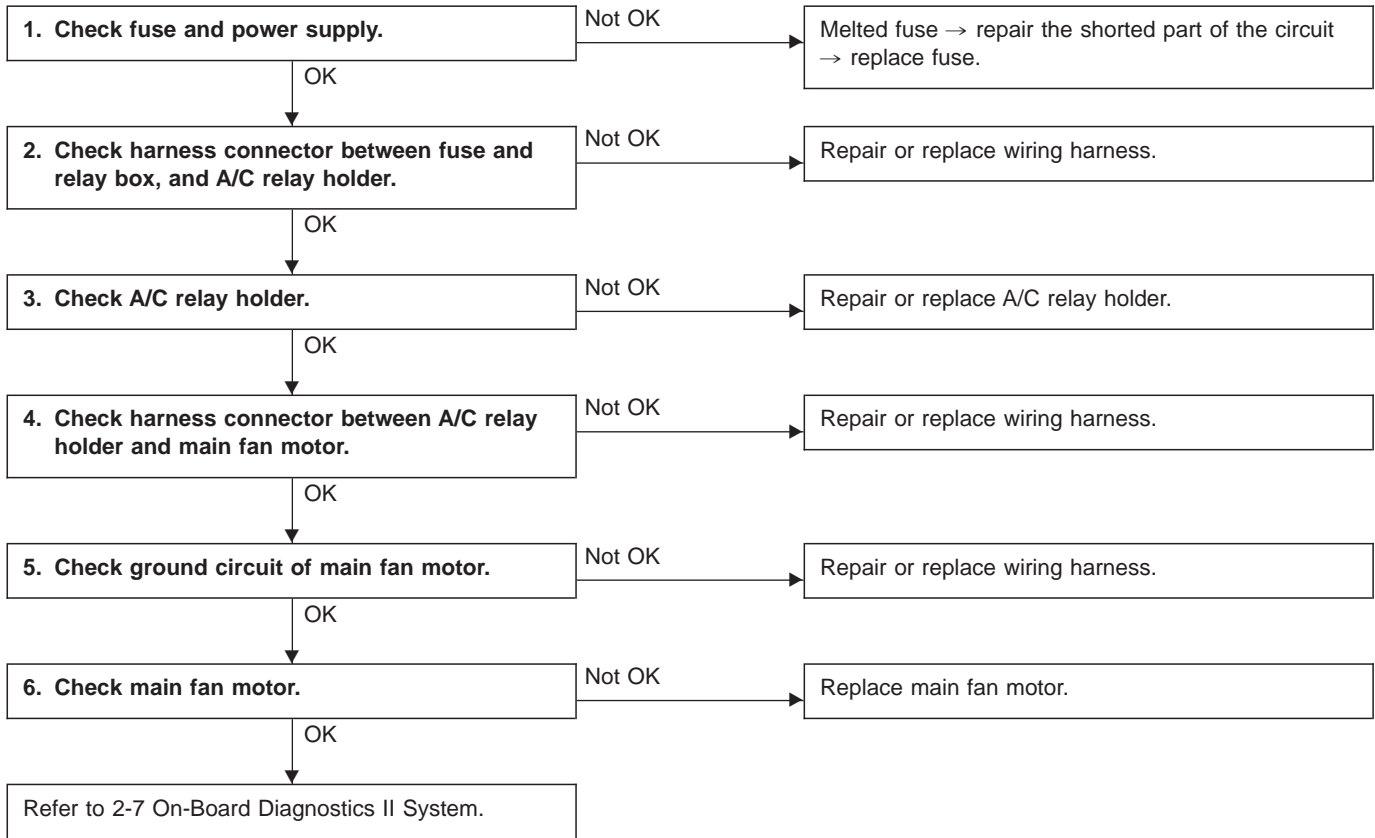

**1. CHECK FUSE AND POWER SUPPLY.**

- 1) Check fuse No. 13.
- 2) Turn ignition switch to ACC.
- 3) Measure voltage between fuse and relay box, and body.

**Connector & terminal / Specified voltage:**  
**(F40) No. 3 — Body / 10 V, or more**

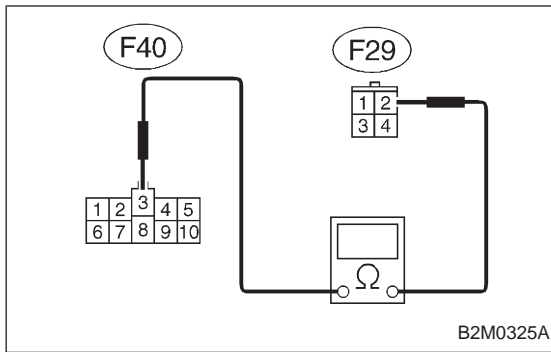

## 2. CHECK HARNESS CONNECTOR BETWEEN FUSE AND RELAY BOX, AND A/C RELAY HOLDER.

- 1) Turn ignition switch to OFF.
- 2) Disconnect connectors from fuse and relay box, and A/C relay holder.
- 3) Measure resistance of harness connector between fuse and relay box, and A/C relay holder.

**Connector & terminal / Specified resistance:**  
**(F40) No. 3 — (F29) No. 2 / 10 Ω, max.**

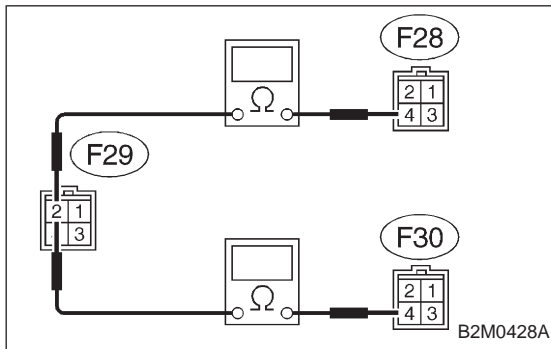

## 3. CHECK A/C RELAY HOLDER.

- 1) Disconnect connector from A/C relay holder.
- 2) Measure resistance between terminals of A/C relay holder.

**Connector & terminal / Specified resistance:**  
**(F29) No. 2 — (F28) No. 4 / 10 Ω, max.**  
**(F29) No. 2 — (F30) No. 4 / 10 Ω, max.**

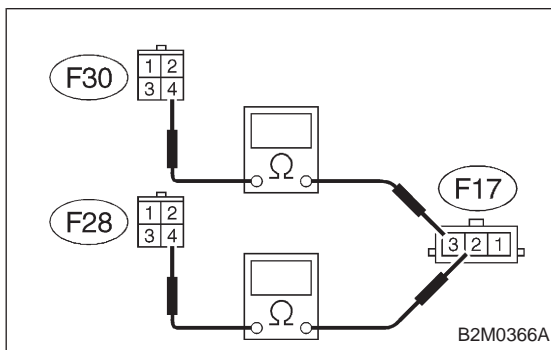

## 4. CHECK HARNESS CONNECTOR BETWEEN A/C RELAY HOLDER AND MAIN FAN MOTOR.

- 1) Disconnect connectors from A/C relay holder and main fan motor.
- 2) Measure resistance of harness connector between A/C relay holder and main fan motor.

**Connector & terminal / Specified resistance:**  
**(F28) No. 4 — (F17) No. 2 / 10 Ω, max.**  
**(F30) No. 4 — (F17) No. 3 / 10 Ω, max.**

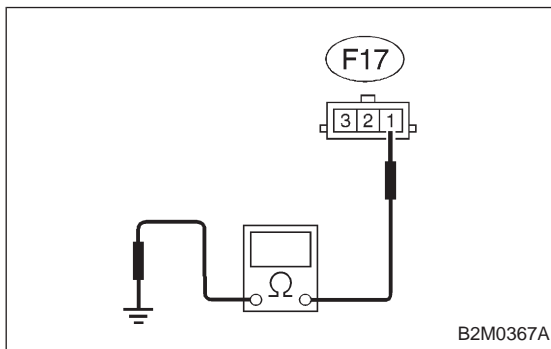

## 5. CHECK GROUND CIRCUIT OF MAIN FAN MOTOR.

Measure resistance between main fan motor connector and body.

**Connector & terminal / Specified resistance:**  
**(F17) No. 1 — Body / 10 Ω, max.**

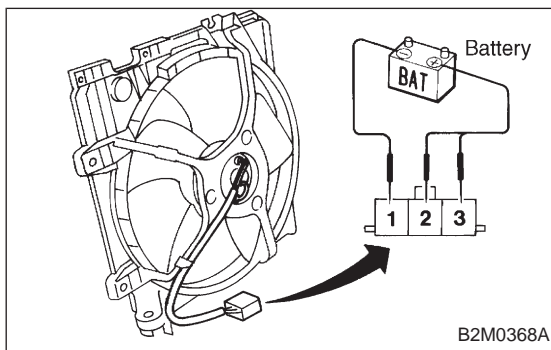

## 6. CHECK MAIN FAN MOTOR.

- 1) Disconnect connector from main fan motor.
- 2) Connect battery positive (+) terminal to terminals No. 2 and No. 3, and connect terminal No. 1 to ground. Ensure that fan rotates.



**B: LO MODE OPERATION (WITH A/C MODEL)****CONDITION:**

Condition (1) :

- Engine coolant temperature is below 89°C (192°F).
- A/C switch is turned ON.
- Vehicle speed is below 10 km/h (6 MPH).

Condition (2) :

- Engine coolant temperature is above 95°C (203°F).
- A/C switch is turned OFF.
- Vehicle speed is below 10 km/h (6 MPH).

**TROUBLE SYMPTOM:**

- Radiator main fan does not rotate at LO speed under conditions (1) and (2) above.

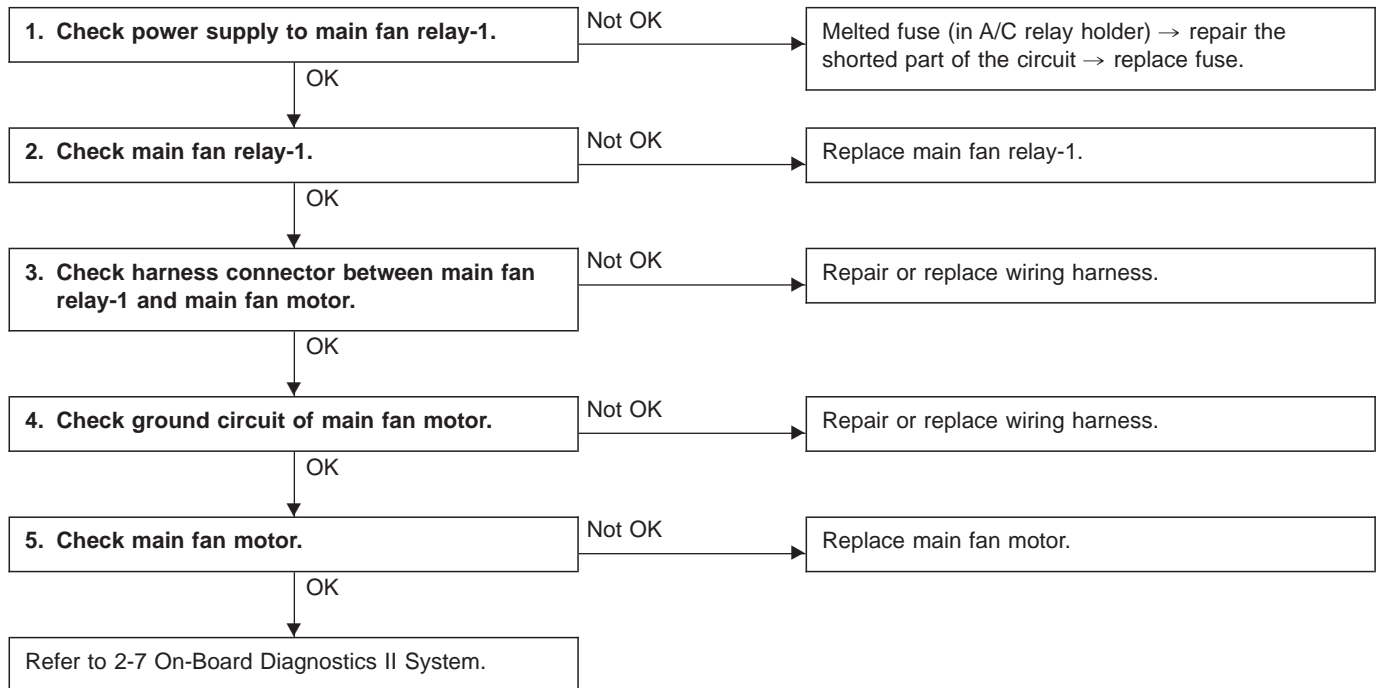

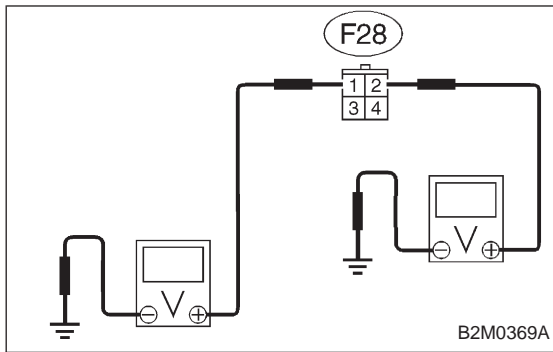

**1. CHECK POWER SUPPLY TO MAIN FAN RELAY-1.**

- 1) Turn ignition switch to OFF.
- 2) Disconnect connector from A/C relay holder.
- 3) Measure voltage between A/C relay holder connector and body.

**Connector & terminal / Specified voltage:**

**(F28) No. 2 — Body / 10 V, or more**

**(F28) No. 1 — Body / 1 V, max.**

- 4) Turn ignition switch to ON.
- 5) Measure voltage between A/C relay holder connector and body.

**Connector & terminal / Specified voltage:**

**(F28) No. 1 — Body / 10 V, or more**

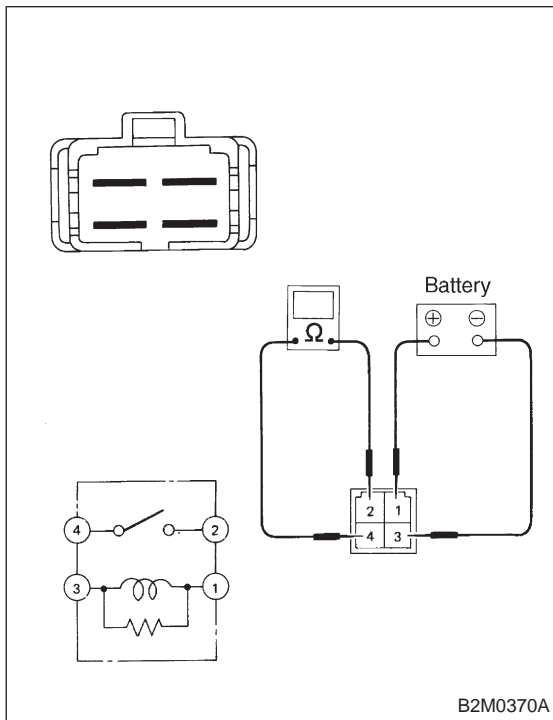

**2. CHECK MAIN FAN RELAY-1.**

- 1) Turn ignition switch to OFF.
- 2) Remove main fan relay-1 from A/C relay holder.
- 3) Check continuity between terminals (indicated in table below) when terminal (1) is connected to battery and terminal (3) is grounded.

When current flows.	Between terminals (2) and (4)	Continuity exists.
When current does not flow.	Between terminals (2) and (4)	Continuity does not exist.
	Between terminals (1) and (3)	Continuity exists.

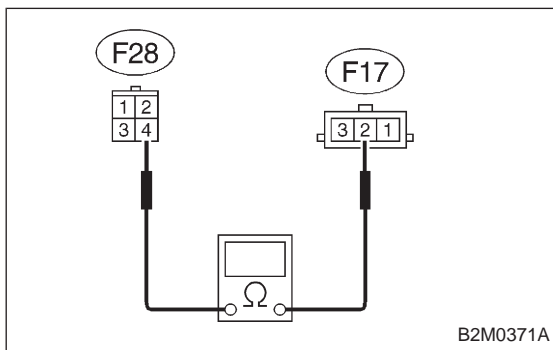

**3. CHECK HARNESS CONNECTOR BETWEEN MAIN FAN RELAY-1 AND MAIN FAN MOTOR.**

- 1) Disconnect connectors from main fan relay-1 and main fan motor.
- 2) Measure resistance of harness connector between main fan relay-1 and main fan motor.

**Connector & terminal / Specified resistance:**

**(F28) No. 4 — (F17) No.2 / 10 Ω, max.**

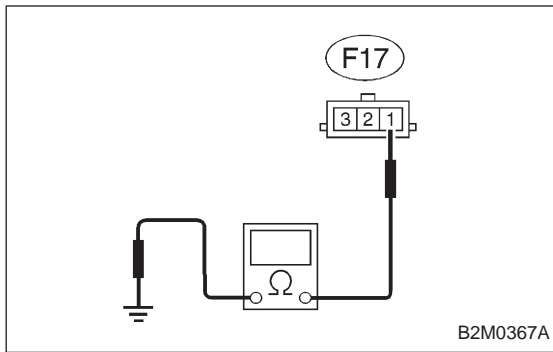

#### 4. CHECK GROUND CIRCUIT OF MAIN FAN MOTOR.

Measure resistance between main fan motor connector and body.

**Connector & terminal / Specified resistance:**  
**(F17) No. 1 — Body / 10 Ω, max.**

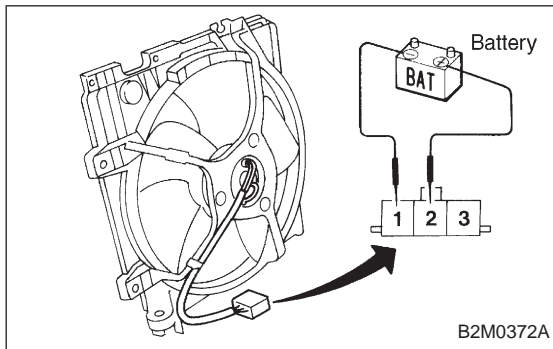

#### 5. CHECK MAIN FAN MOTOR.

- 1) Disconnect connector from main fan motor.
- 2) Connect battery positive (+) terminal to terminal No. 2 and connect terminal No. 1 to ground. Ensure that fan rotates at LO speed.

**C: HI MODE OPERATION (WITH A/C MODEL)****CONDITION:**

Condition (1) :

- Engine coolant temperature is below 89°C (192°F).
- A/C switch is turned ON.
- Vehicle speed is over 20 km/h (12 MPH).

Condition (2) :

- Engine coolant temperature is above 95°C (203°F).
- A/C switch is turned OFF.
- Vehicle speed is over 20 km/h (12 MPH).

Condition (3) :

- Engine coolant temperature is above 95°C (203°F).
- A/C switch is turned ON.

**TROUBLE SYMPTOM:**

- Radiator main fan does not rotate at HI speed under conditions (1), (2) and (3) above.

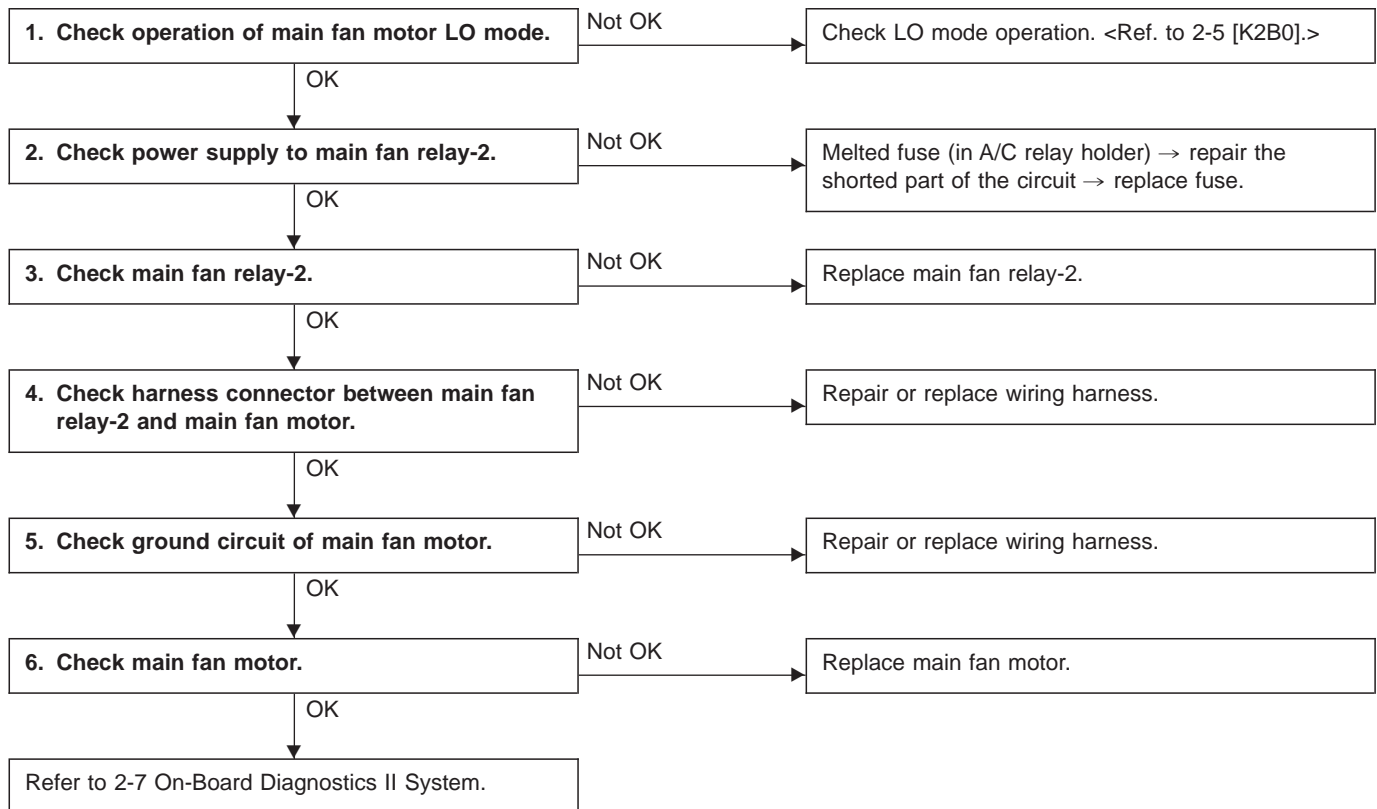

**1. CHECK OPERATION OF MAIN FAN MOTOR LO MODE.**

Check that radiator main fan rotates at LO speed under each condition described under LO mode operation. <Ref. to 2-5 [K2B0].>

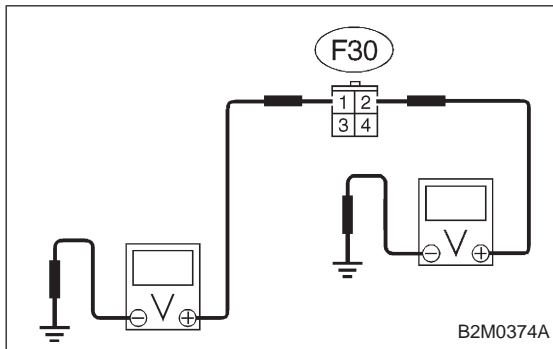

**2. CHECK POWER SUPPLY TO MAIN FAN RELAY-2.**

- 1) Turn ignition switch to OFF.
- 2) Disconnect connector from A/C relay holder.
- 3) Measure voltage between A/C relay holder connector and body.

**Connector & terminal / Specified voltage:**

**(F30) No. 2 — Body / 10 V, or more**

**(F30) No. 1 — Body / 1 V, max.**

- 4) Turn ignition switch to ON.
- 5) Measure voltage between A/C relay holder connector and body.

**Connector & terminal / Specified voltage:**

**(F30) No. 1 — Body / 10 V, or more**

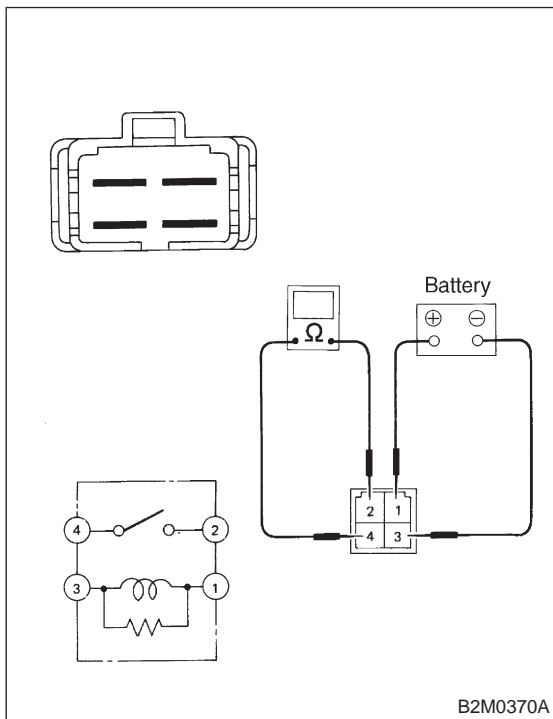

**3. CHECK MAIN FAN RELAY-2.**

- 1) Turn ignition switch to OFF.
- 2) Remove main fan relay-2 from A/C relay holder.
- 3) Check continuity between terminals (indicated in table below) when terminal (1) is connected to battery and terminal (3) is grounded.

When current flows.	Between terminals (2) and (4)	Continuity exists.
When current does not flow.	Between terminals (2) and (4)	Continuity does not exist.
	Between terminals (1) and (3)	Continuity exists.

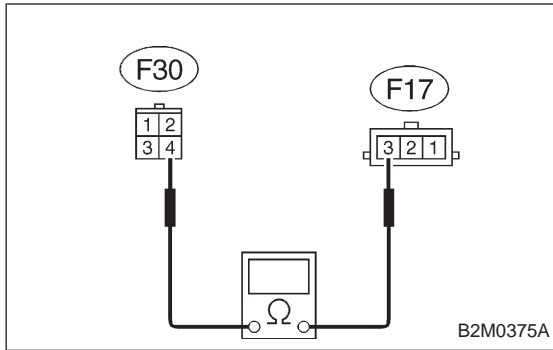

#### 4. CHECK HARNESS CONNECTOR BETWEEN MAIN FAN RELAY-2 AND MAIN FAN MOTOR.

- 1) Disconnect connectors from main fan relay-2 and main fan motor.
- 2) Measure resistance of harness connector between main fan relay-2 and main fan motor.

**Connector & terminal / Specified resistance:**

**(F30) No. 4 — (F17) No. 3 / 10 Ω, max.**

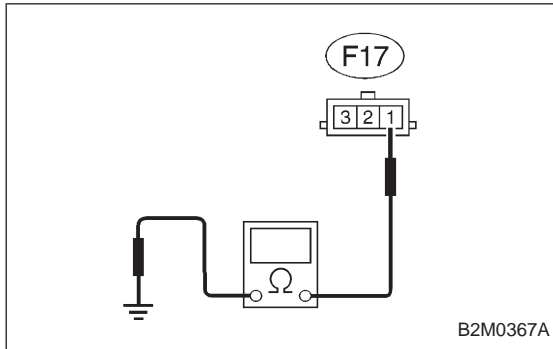

#### 5. CHECK GROUND CIRCUIT OF MAIN FAN MOTOR.

Measure resistance between main fan motor connector and body.

**Connector & terminal / Specified resistance:**

**(F17) No. 1 — Body / 10 Ω, max.**

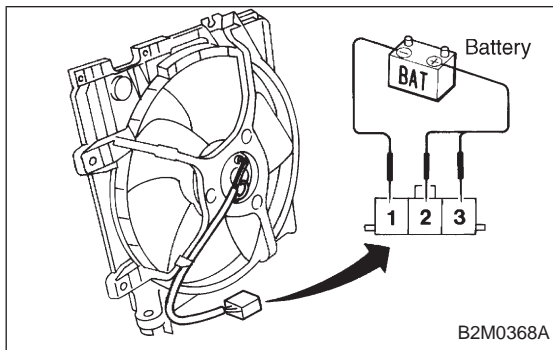

#### 6. CHECK MAIN FAN MOTOR.

- 1) Disconnect connector from main fan motor.
- 2) Connect battery positive (+) terminal to terminals No. 2 and No. 3, and connect terminal No. 1 to ground. Ensure that fan rotates at HI speed.

### 3. Radiator Sub Fan (With A/C model only)

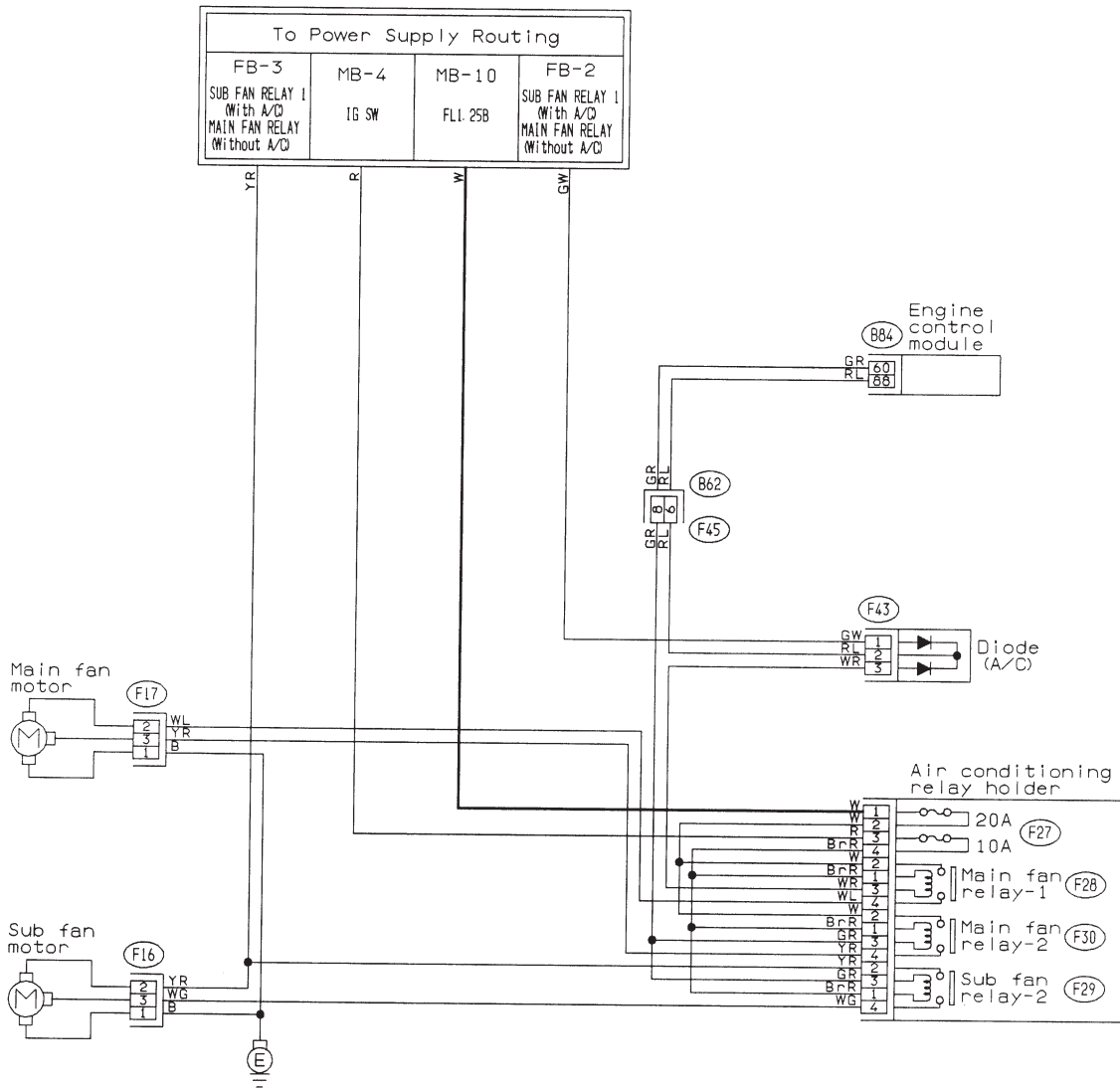

- (F43) (Orange)
- (F16) (Black)
- (F17) (Black)

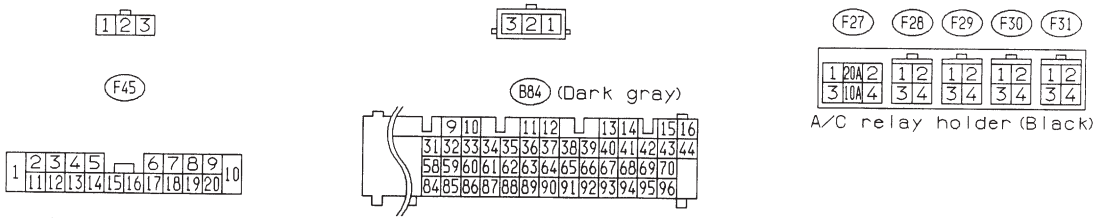

B2M0376

**A: LO MODE OPERATION****CONDITION:**

Condition (1) :

- Engine coolant temperature is below 89°C (192°F).
- A/C switch is turned ON.
- Vehicle speed is below 10 km/h (6 MPH).

Condition (2) :

- Engine coolant temperature is above 95°C (203°F).
- A/C switch is turned OFF.
- Vehicle speed is below 10 km/h (6 MPH).

**TROUBLE SYMPTOM:**

- Radiator sub fan does not rotate at LO speed under conditions (1) and (2) above.

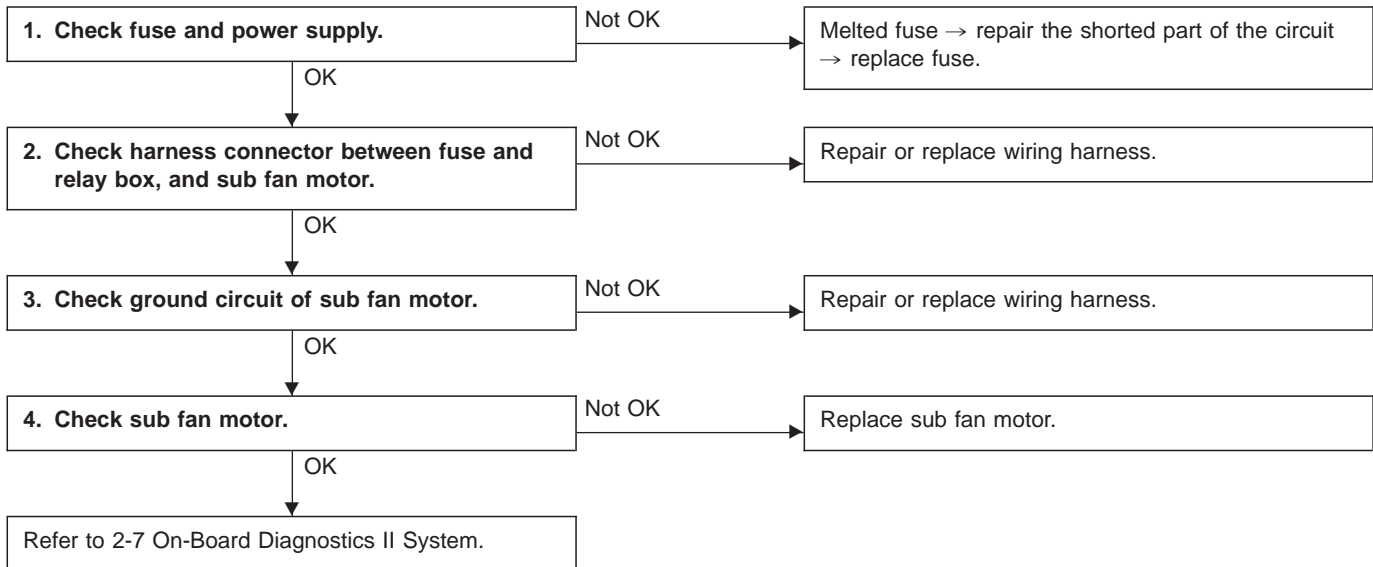

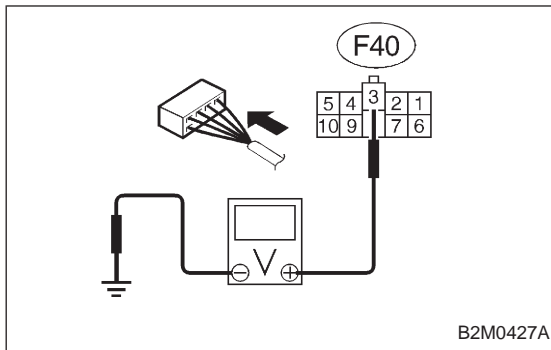

**1. CHECK FUSE AND POWER SUPPLY.**

- 1) Check fuse No. 13.
- 2) Turn ignition switch to ACC.
- 3) Measure voltage between fuse and relay box, and body.

**Connector & terminal / Specified voltage:**  
**(F40) No. 3 — Body / 10 V, or more**

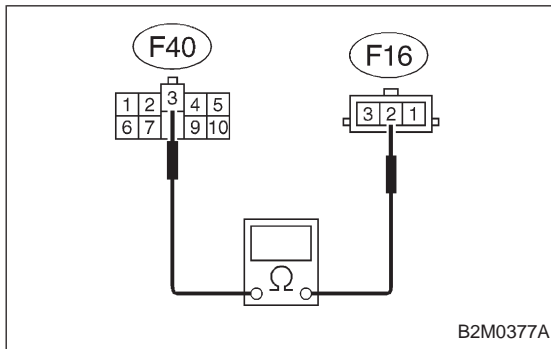
**2. CHECK HARNESS CONNECTOR BETWEEN FUSE AND RELAY BOX, AND SUB FAN MOTOR.**

- 1) Turn ignition switch to OFF.
- 2) Disconnect connectors from fuse and relay box, and sub fan motor.
- 3) Measure resistance of harness connector between fuse and relay box, and sub fan motor.

**Connector & terminal / Specified resistance:**  
**(F40) No. 3 — (F16) No. 2 / 10  $\Omega$ , max.**

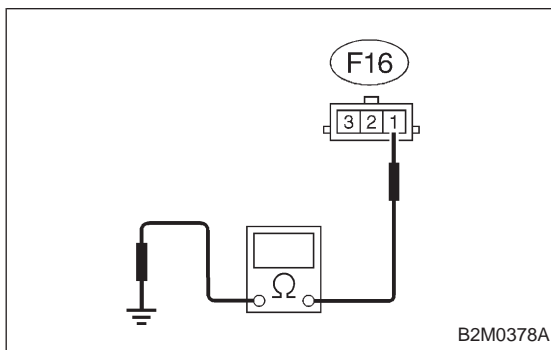
**3. CHECK GROUND CIRCUIT OF SUB FAN MOTOR.**

Measure resistance between sub fan motor connector and body.

**Connector & terminal / Specified resistance:**  
**(F16) No. 1 — Body / 10  $\Omega$ , max.**

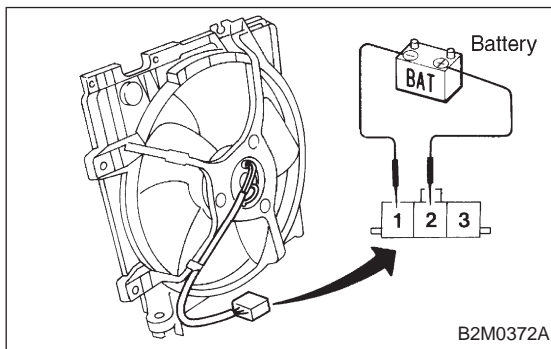
**4. CHECK SUB FAN MOTOR.**

- 1) Disconnect connector from sub fan motor.
- 2) Connect battery positive (+) terminal to terminal No. 2 and connect terminal No. 1 to ground. Ensure that fan rotates at LO speed.

**B: HI MODE OPERATION****CONDITION:**

Condition (1) :

- Engine coolant temperature is below 89°C (192°F).
- A/C switch is turned ON.
- Vehicle speed is over 20 km/h (12 MPH).

Condition (2) :

- Engine coolant temperature is above 95°C (203°F).
- A/C switch is turned OFF.
- Vehicle speed is over 20 km/h (12 MPH).

Condition (3) :

- Engine coolant temperature is above 95°C (203°F).
- A/C switch is turned ON.

**TROUBLE SYMPTOM:**

- Radiator sub fan does not rotate at HI speed under conditions (1), (2) and (3) above.

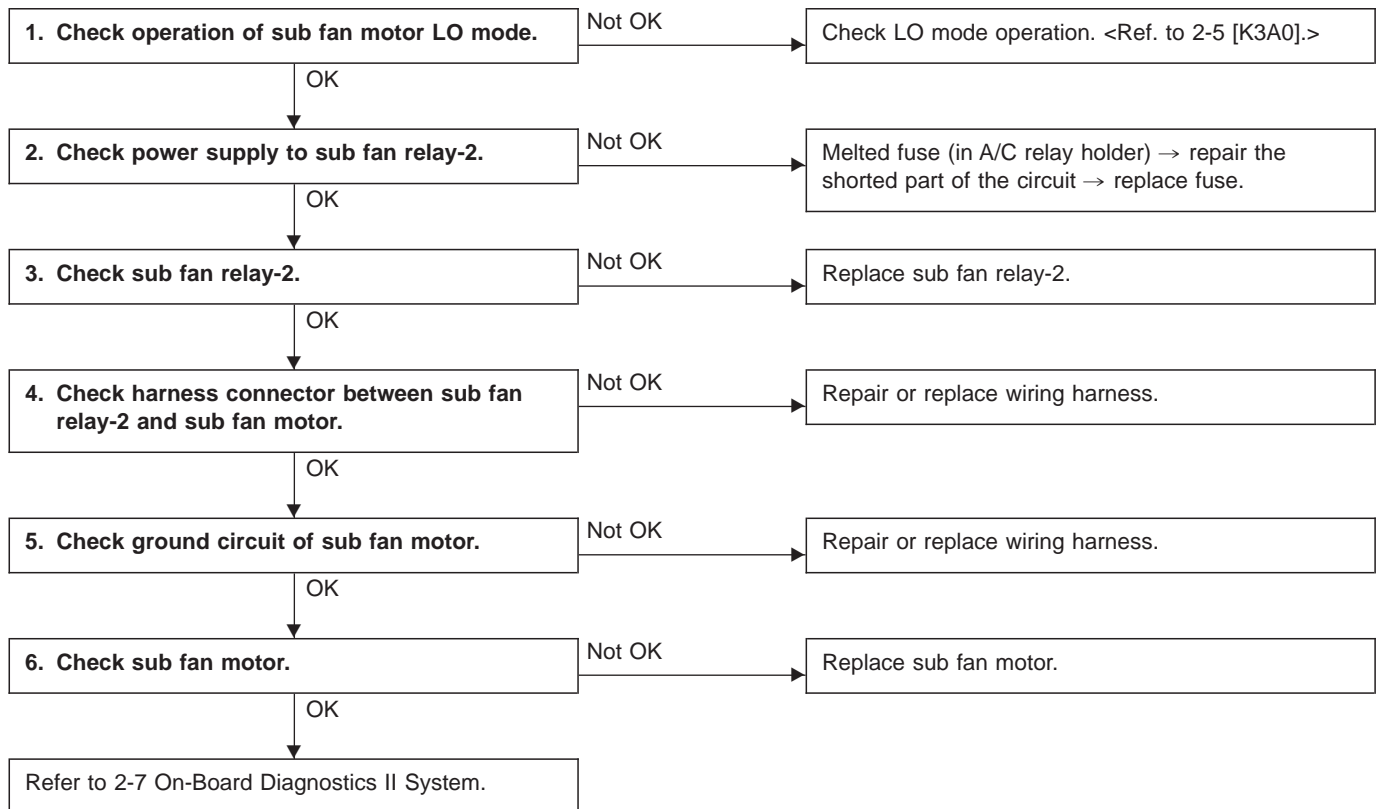

**1. CHECK OPERATION OF SUB FAN MOTOR LO MODE.**

Check that radiator sub fan rotates at LO speed under each condition described under LO mode operation. <Ref. to 2-5 [K3A0].>

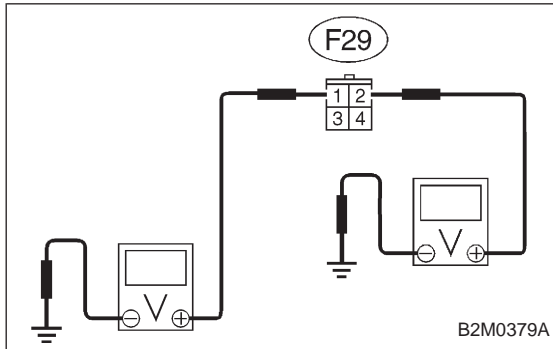

**2. CHECK POWER SUPPLY TO SUB FAN RELAY-2.**

- 1) Turn ignition switch to OFF.
- 2) Disconnect connector from A/C relay holder.
- 3) Measure voltage between A/C relay holder connector and body.

**Connector & terminal / Specified voltage:**

**(F29) No. 1 — Body / 1 V, max.**

**(F29) No. 2 — Body / 1 V, max.**

- 4) Turn ignition switch to ON.
- 5) Measure voltage between A/C relay holder connector and body.

**Connector & terminal / Specified voltage:**

**(F29) No. 1 — Body / 10 V, or more**

**(F29) No. 2 — Body / 10 V, or more**

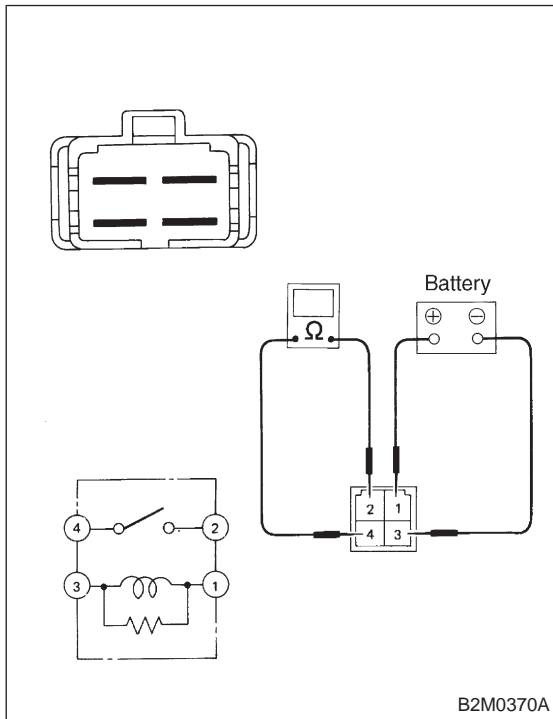

**3. CHECK SUB FAN RELAY-2.**

- 1) Turn ignition switch to OFF.
- 2) Remove sub fan relay-2 from A/C relay holder.
- 3) Check continuity between terminals (indicated in table below) when terminal (1) is connected to battery and terminal (3) is grounded.

When current flows.	Between terminals (2) and (4)	Continuity exists.
When current does not flow.	Between terminals (2) and (4)	Continuity does not exist.
	Between terminals (1) and (3)	Continuity exists.

## 3. Radiator Sub Fan (With A/C model only)

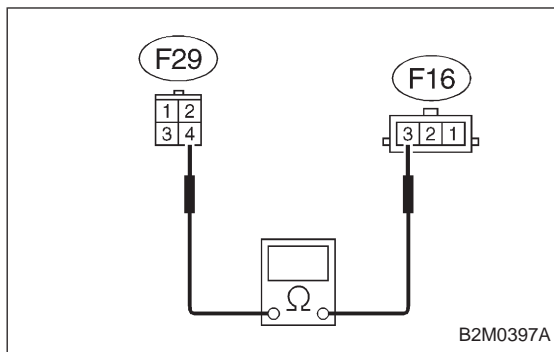
**4. CHECK HARNESS CONNECTOR BETWEEN SUB FAN RELAY-2 AND SUB FAN MOTOR.**

- 1) Disconnect connectors from sub fan relay-2 and sub fan motor.
- 2) Measure resistance of harness connector between sub fan relay-2 and sub fan motor.

**Connector & terminal / Specified resistance:**  
**(F29) No. 4 — (F16) No. 3 / 10  $\Omega$ , max.**

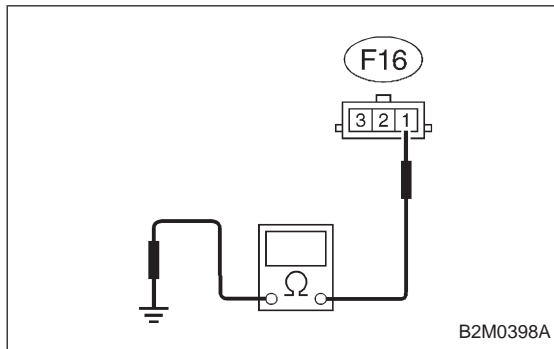
**5. CHECK GROUND CIRCUIT OF SUB FAN MOTOR.**

Measure resistance between sub fan motor connector and body.

**Connector & terminal / Specified resistance:**  
**(F16) No. 1 — Body / 10  $\Omega$ , max.**

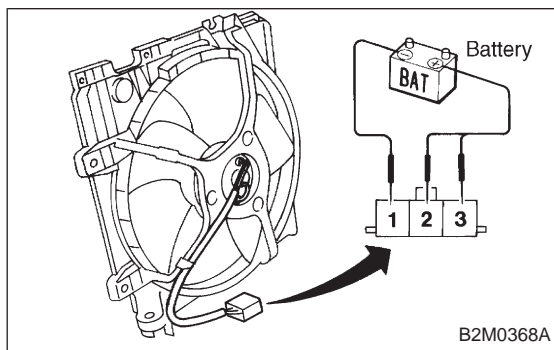
**6. CHECK SUB FAN MOTOR.**

- 1) Disconnect connector from sub fan motor.
- 2) Connect battery positive (+) terminal to terminals No. 2 and No.3, and connect terminal No. 1 to ground. Ensure that fan rotates at HI speed.

# 1. Collector Chamber and Intake Manifold

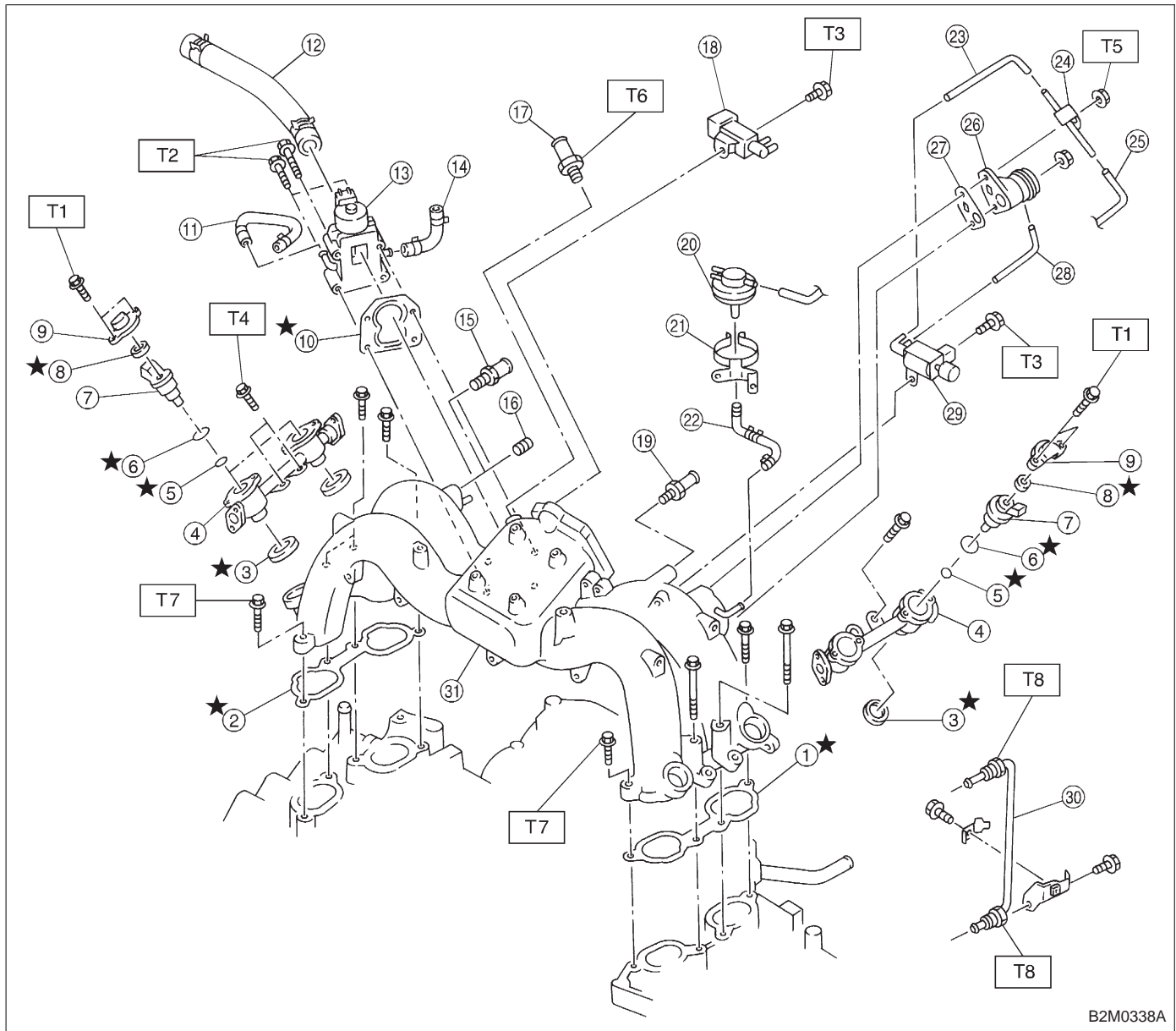

B2M0338A

- |                                   |                      |
|-----------------------------------|----------------------|
| ① Intake manifold gasket RH       | ⑮ Nipple (AT model)  |
| ② Intake manifold gasket LH       | ⑯ Plug               |
| ③ Fuel injector pipe insulator    | ⑰ PCV valve          |
| ④ Fuel injector pipe              | ⑱ Nipple             |
| ⑤ O-ring A                        | ⑳ BPT                |
| ⑥ O-ring B                        | ㉑ BPT holder bracket |
| ⑦ Fuel injector                   | ㉒ Back pressure hose |
| ⑧ Insulator                       | ㉓ EGR vacuum hose A  |
| ⑨ Fuel injector cap               | ㉔ EGR vacuum pipe    |
| ⑩ Gasket                          | ㉕ EGR vacuum hose C  |
| ⑪ Engine coolant hose B           | ㉖ EGR valve          |
| ⑫ Air by-pass hose                | ㉗ Gasket             |
| ⑬ Idle air control solenoid valve | ㉘ EGR vacuum hose B  |
| ⑭ Engine coolant hose A           |                      |

- |                      |
|----------------------|
| ㉚ EGR solenoid valve |
| ⑳ EGR pipe           |
| ㉛ Intake manifold    |

**Tightening torque: N·m (kg·m, ft·lb)**

- T1: 3.4±0.5 (0.35±0.05, 2.5±0.4)  
 T2: 6.4±0.5 (0.65±0.05, 4.7±0.4)  
 T3: 16±1.5 (1.6±0.15, 11.6±1.1)  
 T4: 19±1 (1.9±0.1, 13.7±0.7)  
 T5: 19±1.5 (1.9±0.15, 13.7±1.1)  
 T6: 23±3 (2.3±0.3, 16.6±2.2)  
 T7: 25±2 (2.5±0.2, 18.1±1.4)  
 T8: 34±2 (3.5±0.2, 25.3±1.4)

2. Air Intake System

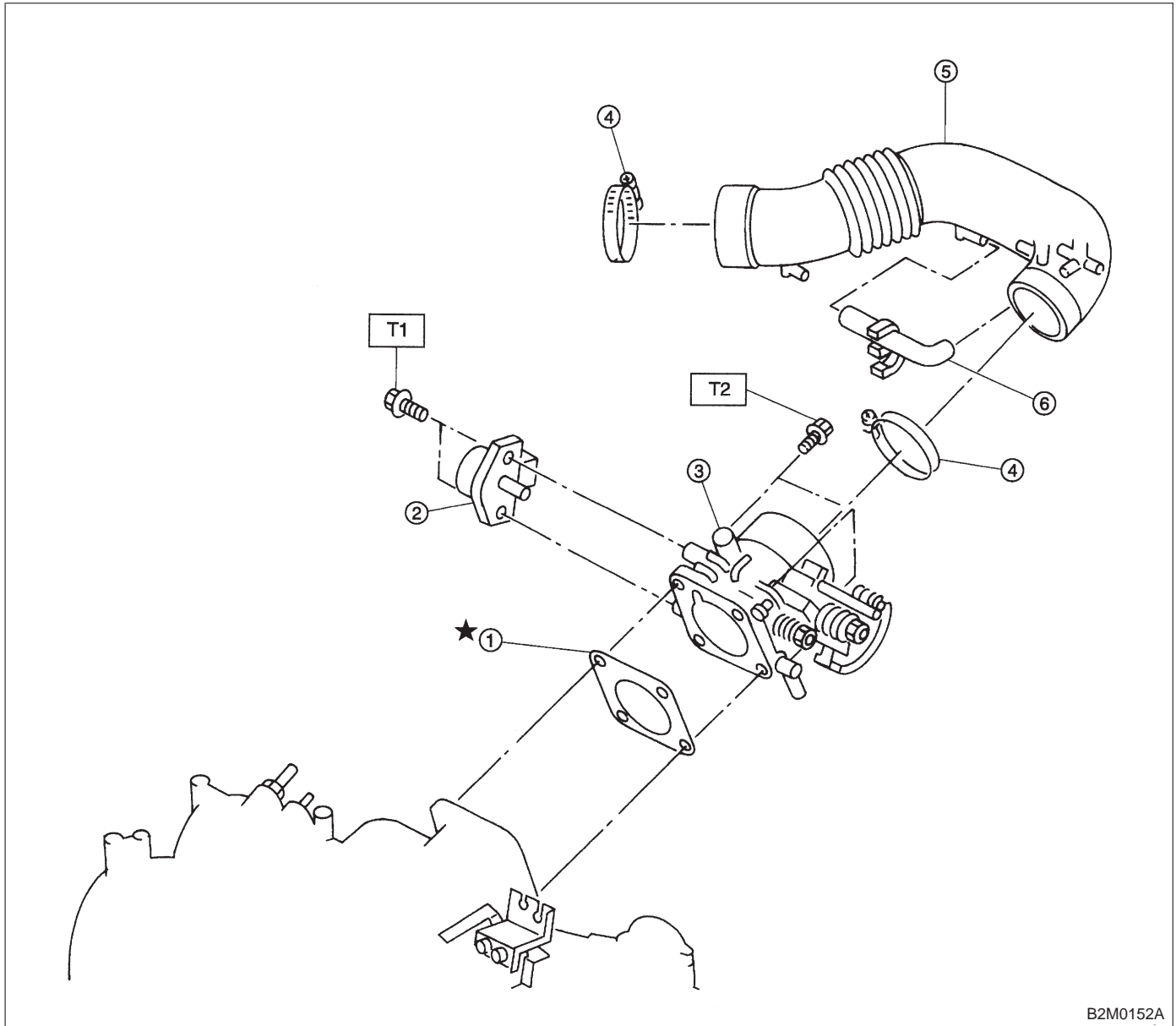

B2M0152A

- ① Gasket
- ② Throttle position sensor
- ③ Throttle body
- ④ Clamp
- ⑤ Air intake duct
- ⑥ By-pass hose

**Tightening torque: N·m (kg·m, ft·lb)**  
**T1: 2.2±0.2 (0.22±0.02, 1.6±0.1)**  
**T2: 22±2 (2.2±0.2, 15.9±1.4)**

## 3. Air Cleaner

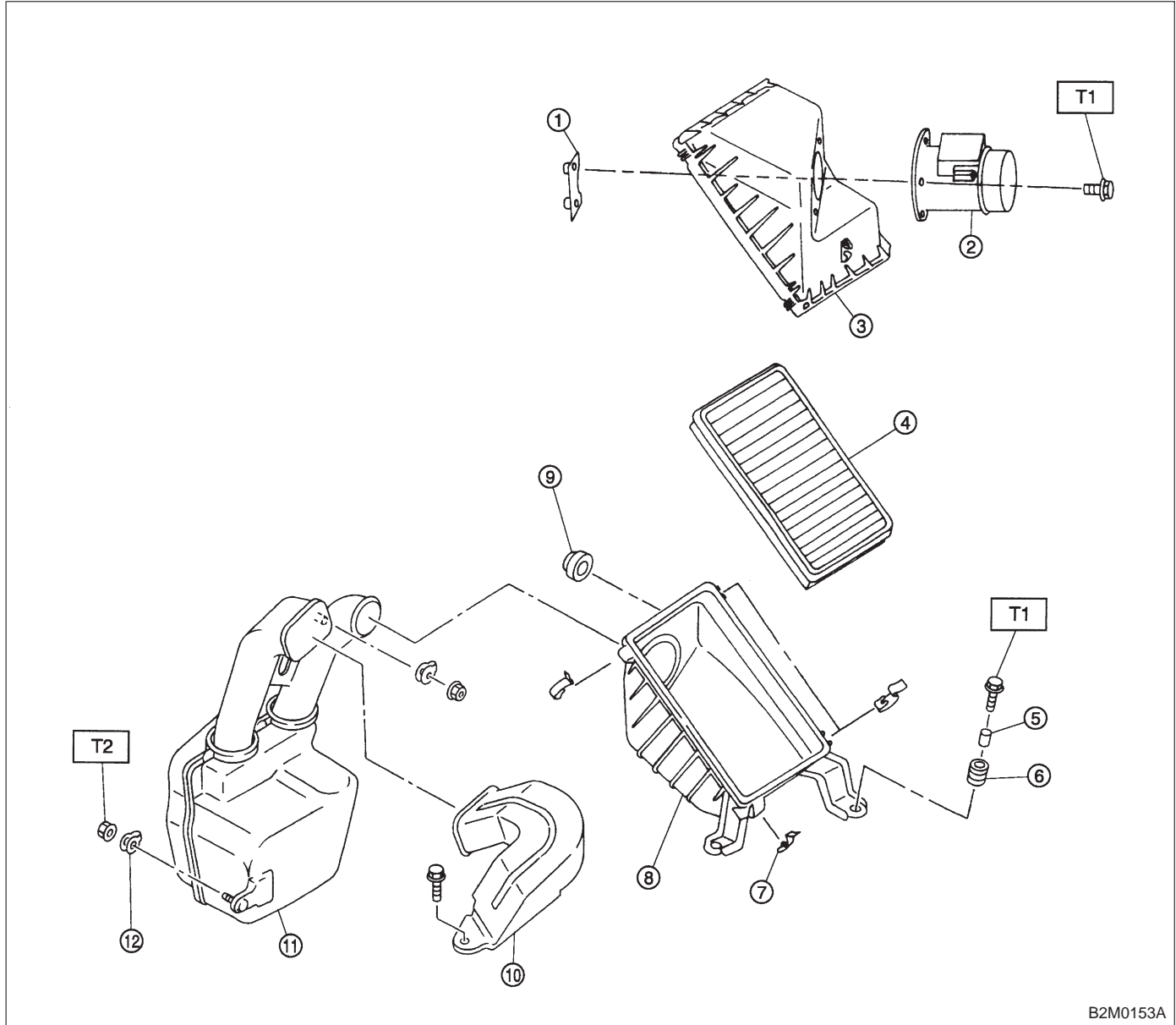

B2M0153A

- ① Mass air flow sensor bracket
- ② Mass air flow sensor ASSY
- ③ Air cleaner upper cover
- ④ Air cleaner element
- ⑤ Spacer
- ⑥ Bush
- ⑦ Clip
- ⑧ Air cleaner case
- ⑨ Cushion rubber

- ⑩ Air intake duct
- ⑪ Resonator chamber ASSY
- ⑫ Clip

**Tightening torque: N·m (kg·m, ft·lb)**

**T1: 7.4±2.0 (0.75±0.2, 5.4±1.4)**

**T2: 33±10 (3.4±1.0, 25±7)**

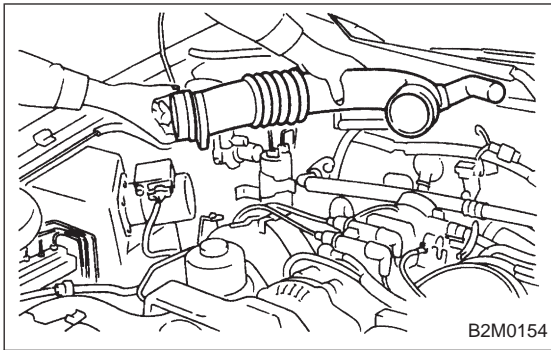

## 1. Air Cleaner and Air Intake Duct

### A: REMOVAL AND INSTALLATION

- 1) Loosen clamp which connect air intake duct to throttle body and mass air flow sensor.
- 2) Disconnect blow-by hoses from air intake duct.
- 3) Remove air intake duct.

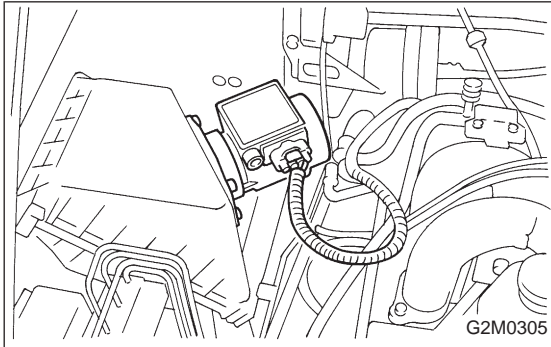

- 4) Disconnect connector from mass air flow sensor.

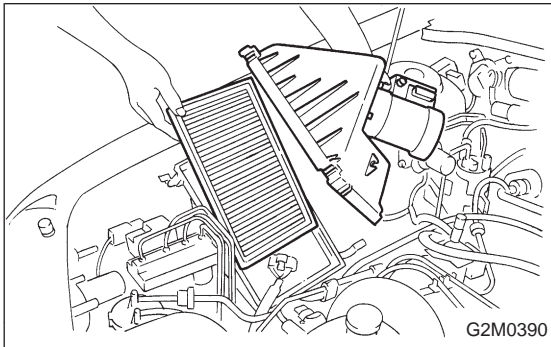

- 5) Remove clips of air cleaner upper cover.
- 6) Remove air cleaner element.

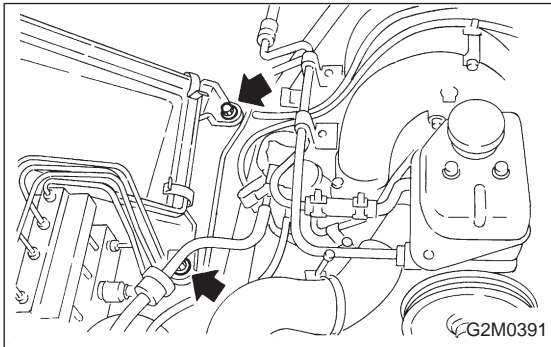

- 7) Remove air cleaner lower case.

- 8) Installation is in the reverse order of removal.



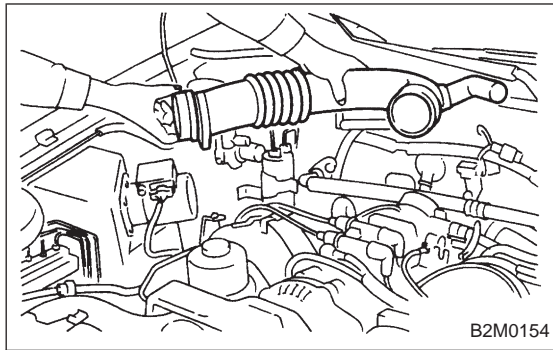

## 2. Mass Air Flow Sensor

### A: REMOVAL AND INSTALLATION

1) Remove air intake duct.

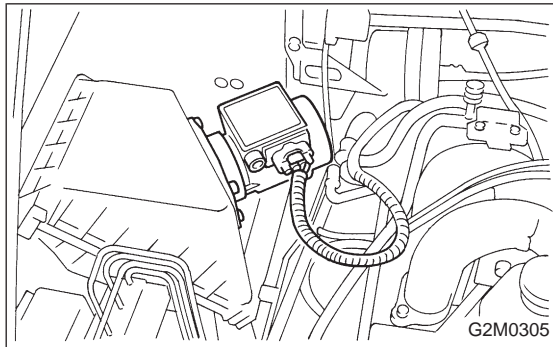

2) Disconnect connector from mass air flow sensor.

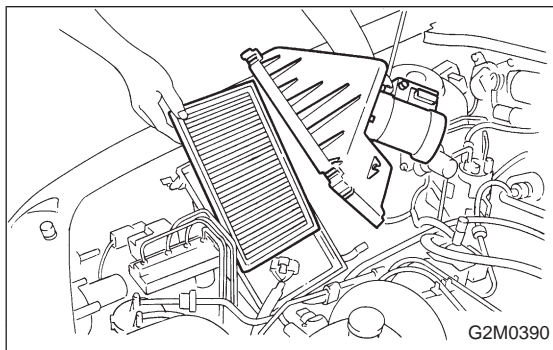

3) Remove air cleaner upper cover.

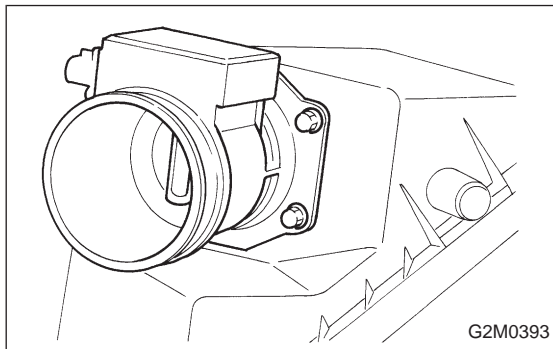

4) Remove mass air flow sensor from air cleaner upper cover.

5) Installation is in the reverse order of removal.

#### **Tightening torque:**

**$7.4 \pm 2.0 \text{ N}\cdot\text{m}$  ( $0.75 \pm 0.2 \text{ kg}\cdot\text{m}$ ,  $5.4 \pm 1.4 \text{ ft}\cdot\text{lb}$ )**

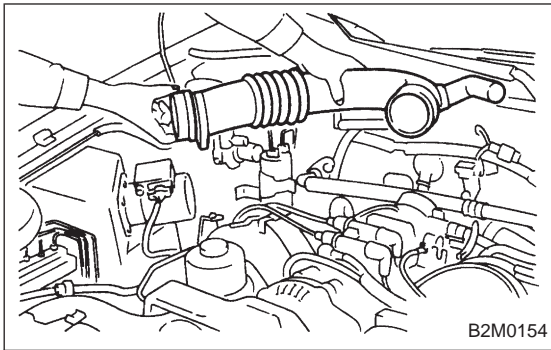

### 3. Throttle Body

#### A: REMOVAL AND INSTALLATION

1) Remove air intake duct.

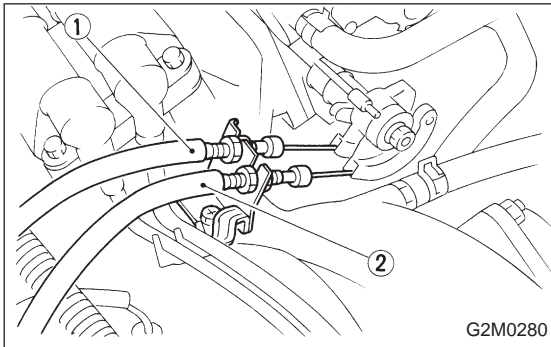

2) Disconnect accelerator cable ①.

3) Disconnect cruise control cable ②. (With cruise control model)

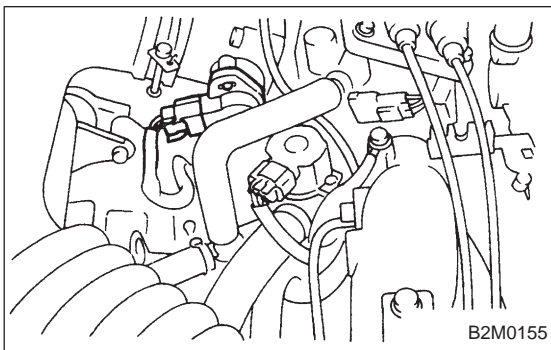

4) Disconnect connector from throttle position sensor.

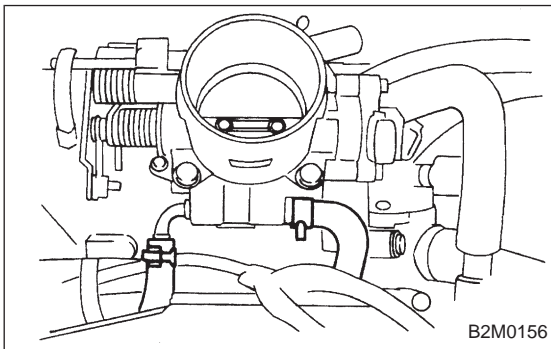

5) Disconnect engine coolant hoses from throttle body.

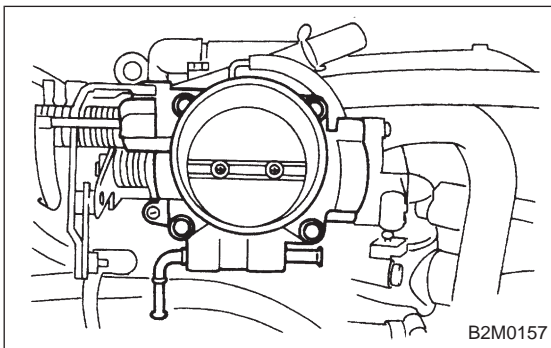

6) Remove bolts which install throttle body to intake manifold.

7) Installation is in the reverse order of removal.

#### CAUTION:

Always use a new gasket.

#### Tightening torque:

$22\pm 2$  N·m ( $2.2\pm 0.2$  kg·m,  $15.9\pm 1.4$  ft·lb)

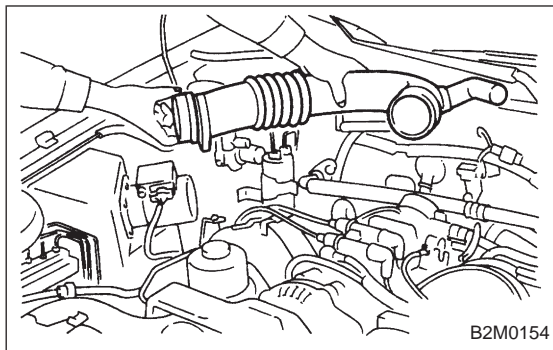

## 4. Intake Manifold

### A: REMOVAL

- 1) Release fuel pressure. <Ref. to 2-8 [W1A0].>
- 2) Disconnect connector from mass air flow sensor.
- 3) Remove air intake duct, air cleaner upper cover and air cleaner element.

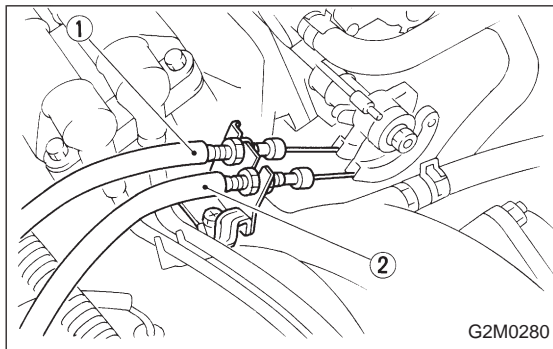

- 4) Disconnect accelerator cable ①.
- 5) Disconnect cruise control cable ②. (With cruise control model)

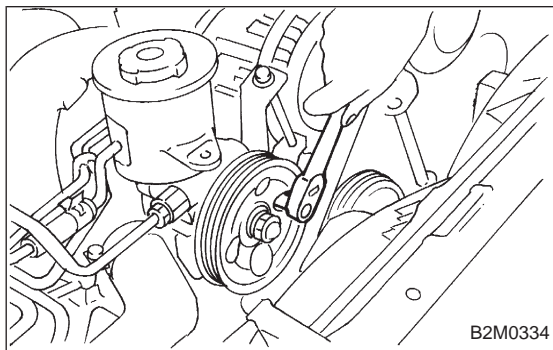

- 6) Disconnect hoses from pressure sources switching solenoid valve.

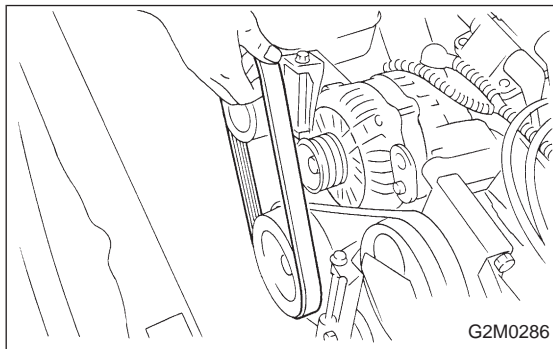

- 7) Remove power steering pump from bracket.
  - (1) Loosen lock bolt and slider bolt, and remove front side V-belt.

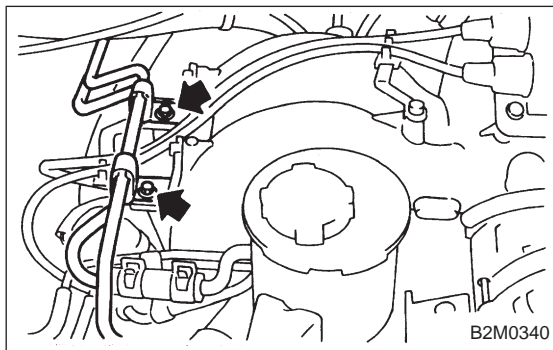

- (2) Remove pipe with bracket from intake manifold.

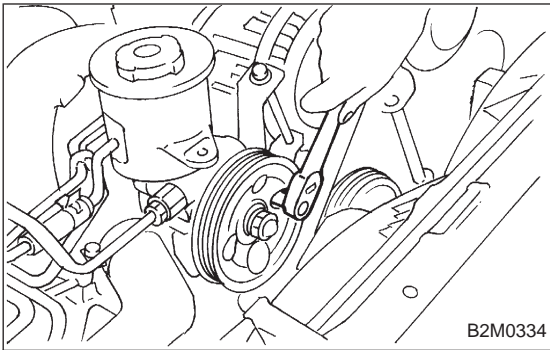

(3) Remove bolts which install power steering pump from bracket.

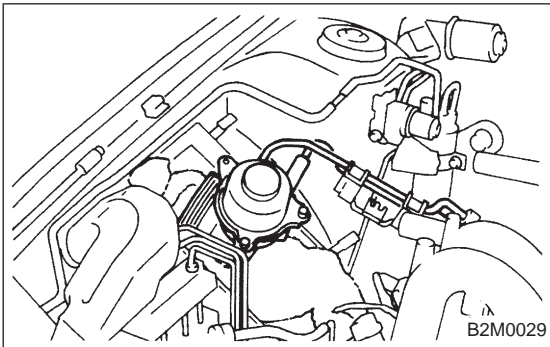

(4) Place power steering pump on the right side wheel apron.

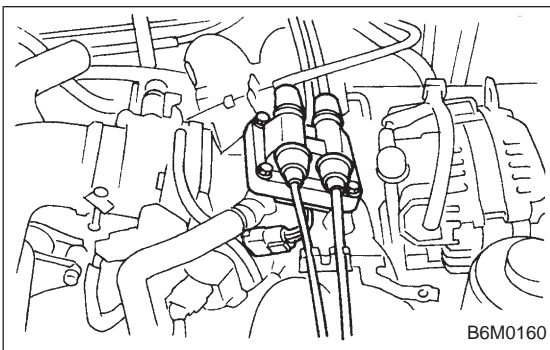

8) Disconnect spark plug cords from ignition coil.

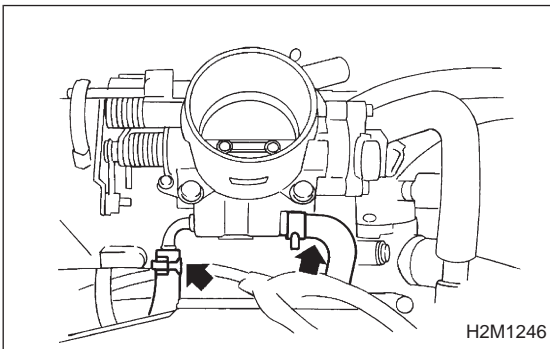

9) Disconnect engine coolant hoses from throttle body.

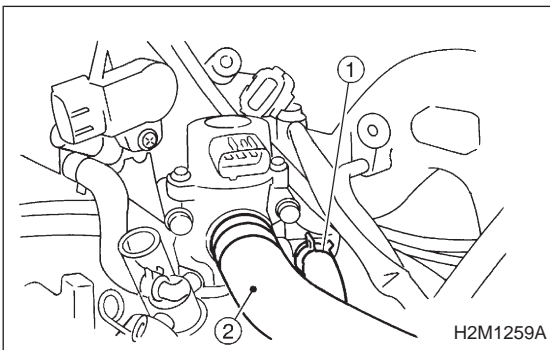

10) Disconnect engine coolant hose ① from idle air control solenoid valve.

11) Disconnect air by-pass hose ② from idle air control solenoid valve.

## 4. Intake Manifold

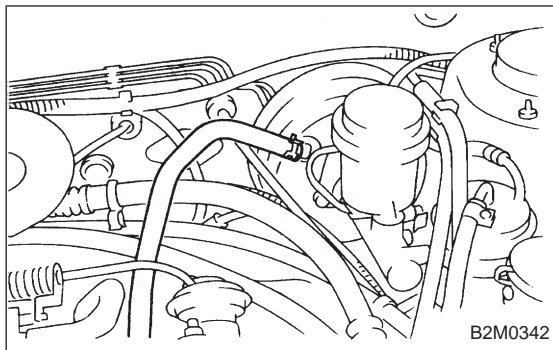

12) Disconnect brake booster hose.

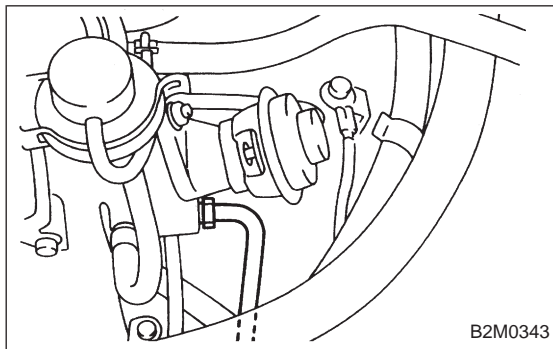

13) Remove EGR pipe.

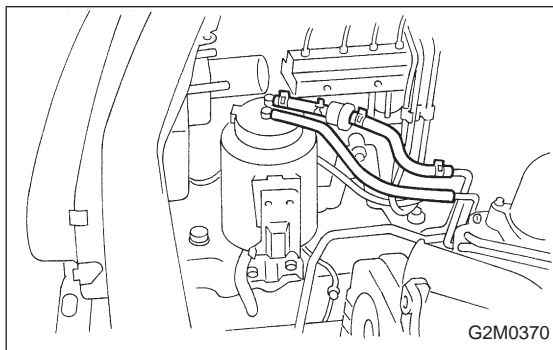

14) Disconnect canister hose from pipe.

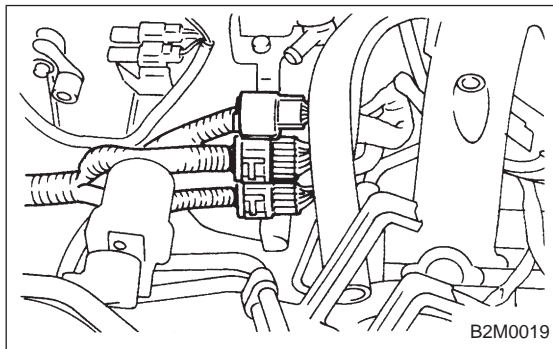

15) Disconnect engine harness connectors from bulkhead harness connectors.

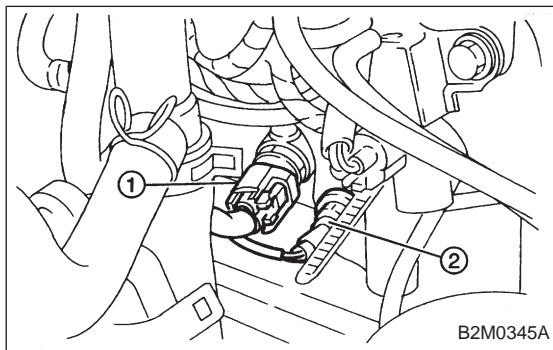

16) Disconnect connectors from engine coolant temperature sensor ① and thermometer ②.

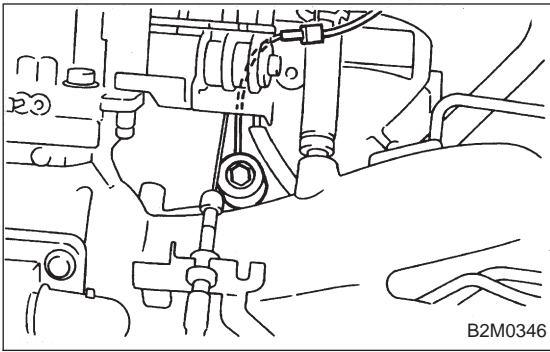

17) Disconnect connector from knock sensor.

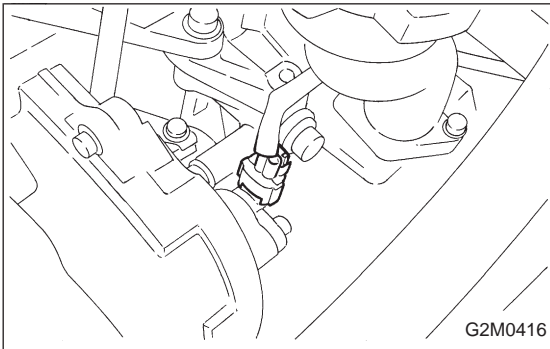

18) Disconnect connector from camshaft position sensor.

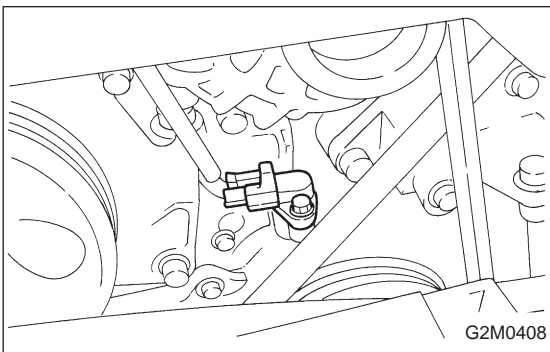

19) Disconnect connector from crankshaft position sensor.

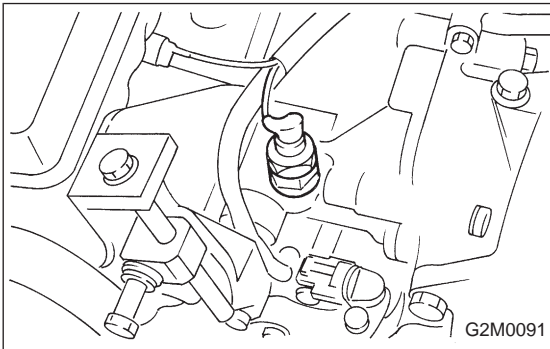

20) Disconnect connector from oil pressure switch.

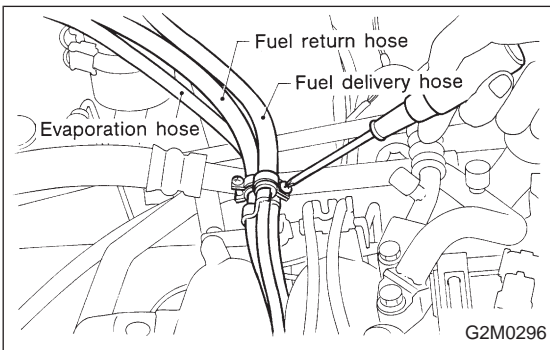

21) Disconnect fuel hoses from pipes.

**WARNING:**  
Catch fuel from hoses in a container.

## 4. Intake Manifold

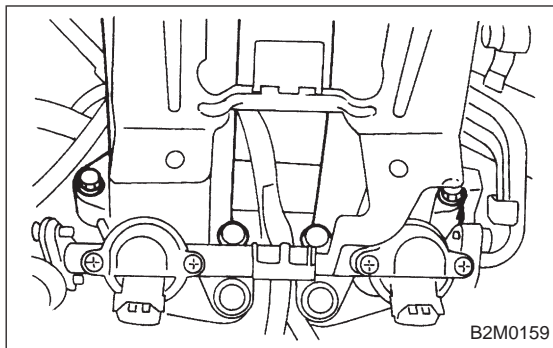

22) Remove bolts which hold intake manifold onto cylinder heads.

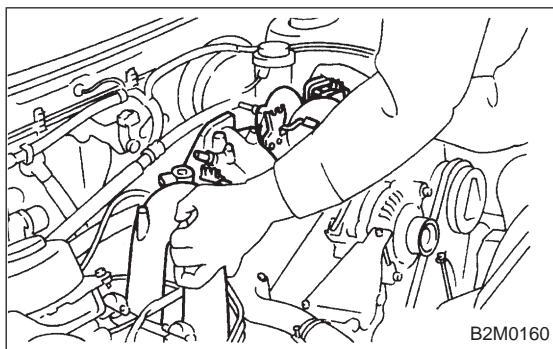

23) Remove intake manifold.

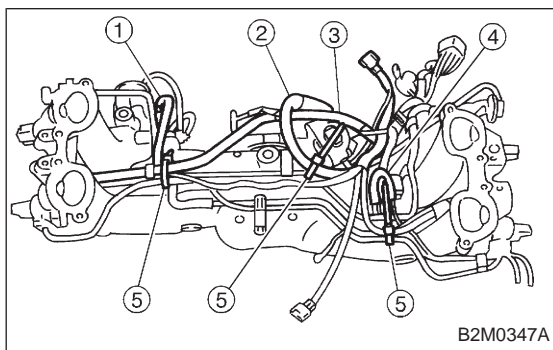
**B: DISASSEMBLY**

1) Disconnect connectors from throttle position sensor, ignition coil, fuel injectors, idle air control solenoid valve, purge control solenoid valve and EGR solenoid valve.

2) Remove engine harness from intake manifold.

- ① EGR solenoid valve
- ② Throttle position sensor
- ③ Idle air control solenoid valve
- ④ Purge control solenoid valve
- ⑤ Harness band

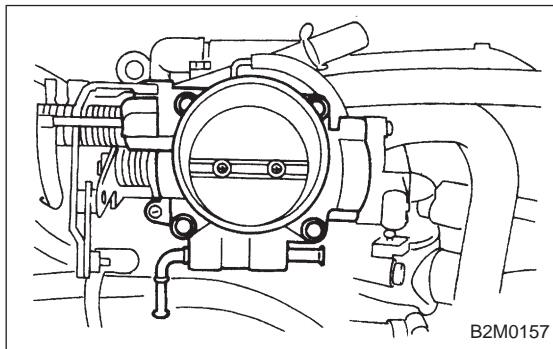

3) Remove throttle body from intake manifold.

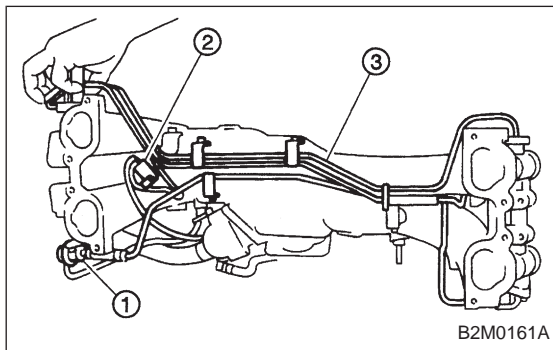

4) Remove fuel pipes, etc. from intake manifold.

- ① Pressure regulator
- ② Purge control solenoid valve
- ③ Fuel pipe ASSY

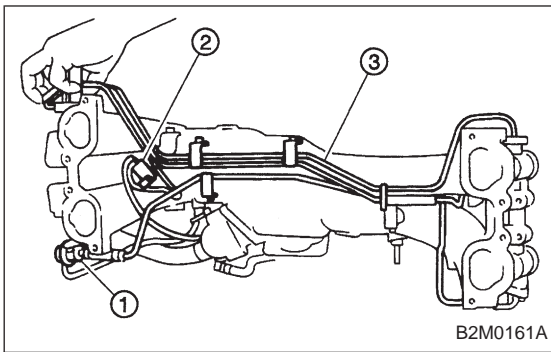

**C: ASSEMBLY**

1) Assemble fuel pipes, etc. to intake manifold.

- ① Pressure regulator
- ② Purge control solenoid valve
- ③ Fuel pipe ASSY

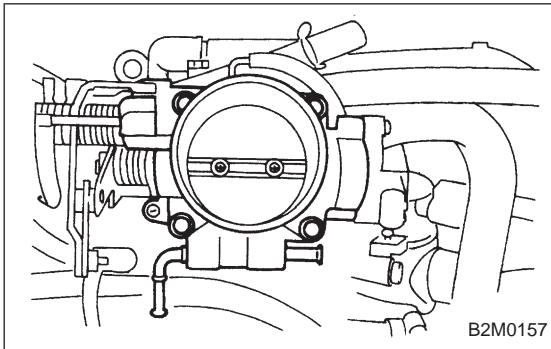

2) Assemble throttle body to intake manifold.

**CAUTION:**

Replace gasket with a new one.

**Tightening torque:**

$22\pm 2$  N·m ( $2.2\pm 0.2$  kg·m,  $15.9\pm 1.4$  ft·lb)

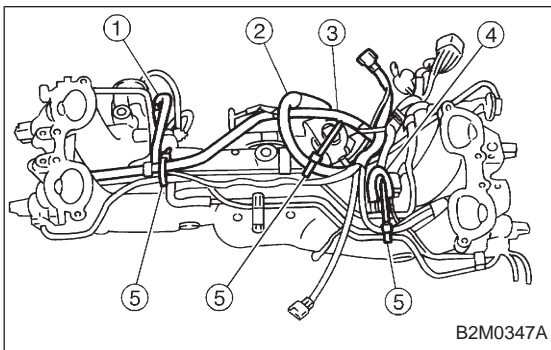

3) Install engine harness onto intake manifold.

4) Connect connectors to throttle position sensor, ignition coil, fuel injectors, idle air control solenoid valve, purge control solenoid valve and EGR solenoid valve.

- ① EGR solenoid valve
- ② Throttle position sensor
- ③ Idle air control solenoid valve
- ④ Purge control solenoid valve
- ⑤ Harness band

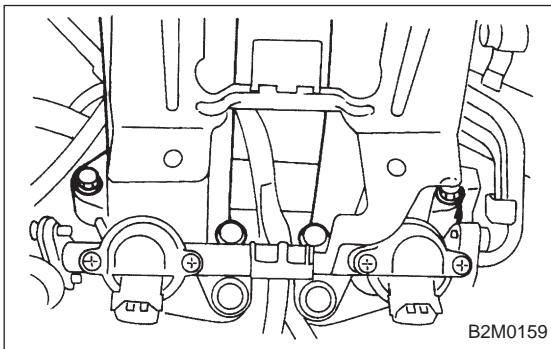

**D: INSTALLATION**

1) Install intake manifold onto cylinder heads.

**CAUTION:**

Always use new gaskets.

**Tightening torque:**

$25\pm 2$  N·m ( $2.5\pm 0.2$  kg·m,  $18.1\pm 1.4$  ft·lb)

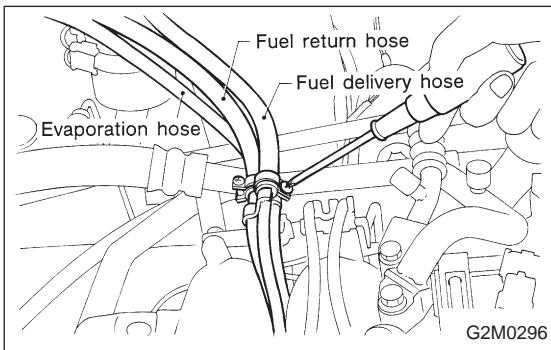

2) Connect fuel hoses.



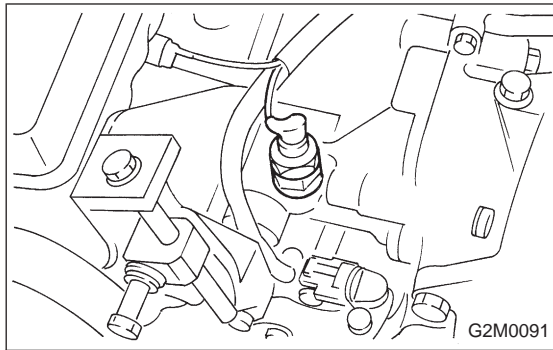

3) Connect connector to oil pressure switch.

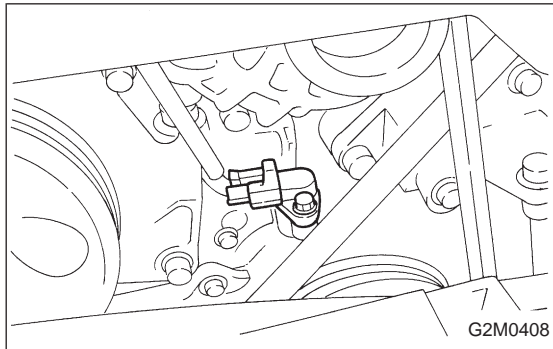

4) Connect connector to crankshaft position sensor.

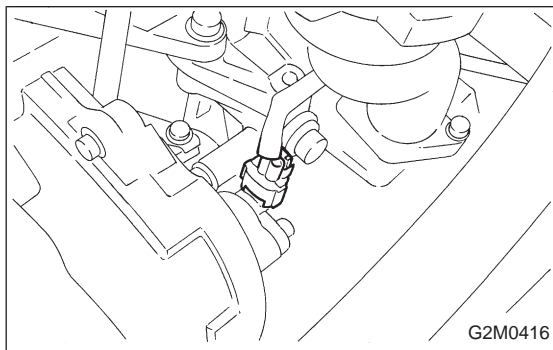

5) Connect connector to camshaft position sensor.

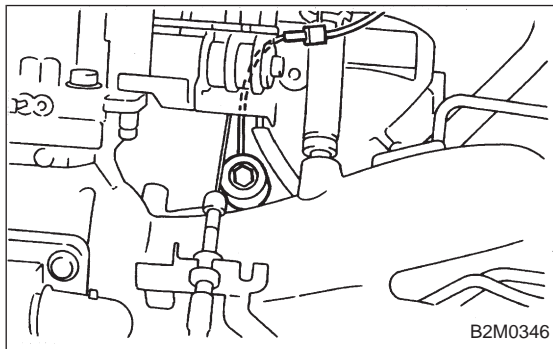

6) Connect connector to knock sensor.

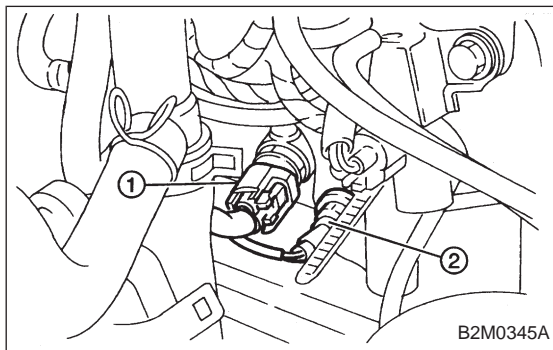

7) Connect connectors to engine coolant temperature sensor ① and thermometer ②.

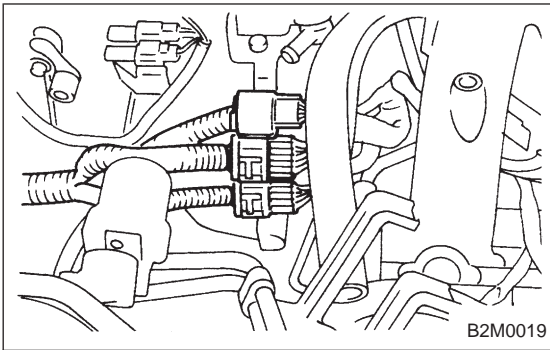

8) Connect engine harness connector to bulkhead harness connectors.

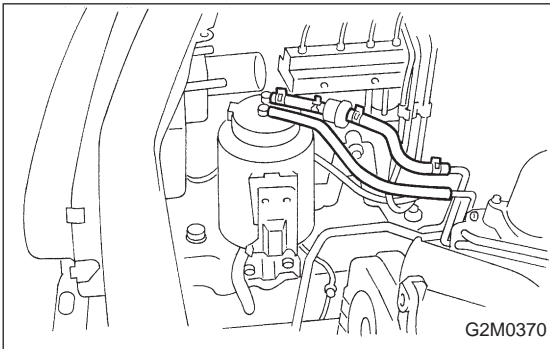

9) Connect canister hoses.

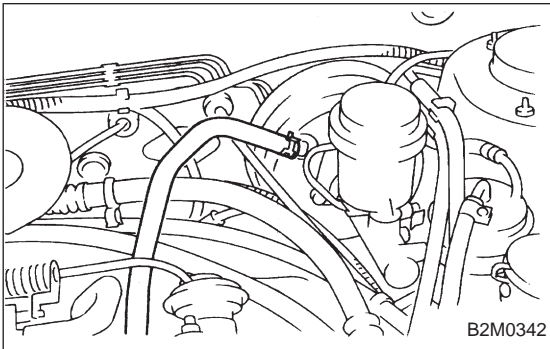

10) Connect brake booster vacuum hose.

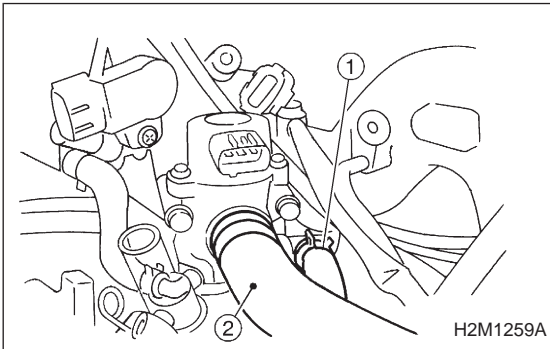

11) Connect engine coolant hose ① to idle air control solenoid valve.

12) Connect air by-pass hose ② to idle air control solenoid valve.

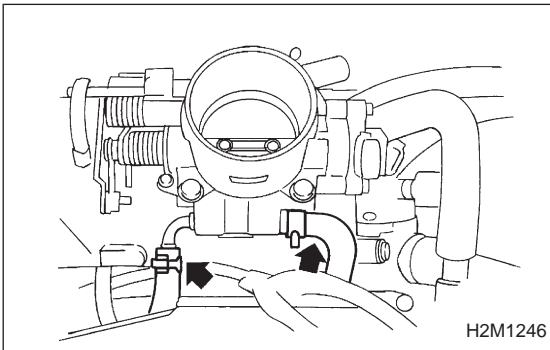

13) Connect engine coolant hoses to throttle body.

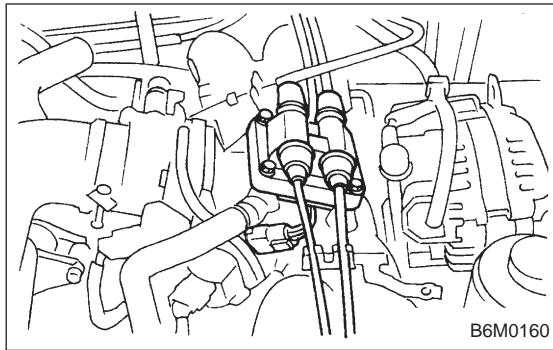

14) Connect spark plug cords to ignition coil.

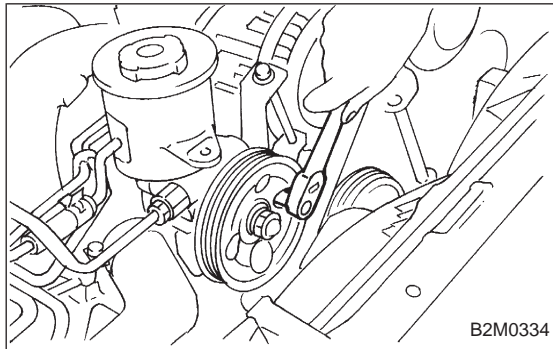

15) Install power steering pump on bracket.

(1) Install power steering pump on bracket, and tighten bolts.

**Tightening torque:**

**$20.1 \pm 2.5 \text{ N}\cdot\text{m}$  ( $2.05 \pm 0.25 \text{ kg}\cdot\text{m}$ ,  $14.8 \pm 1.8 \text{ ft}\cdot\text{lb}$ )**

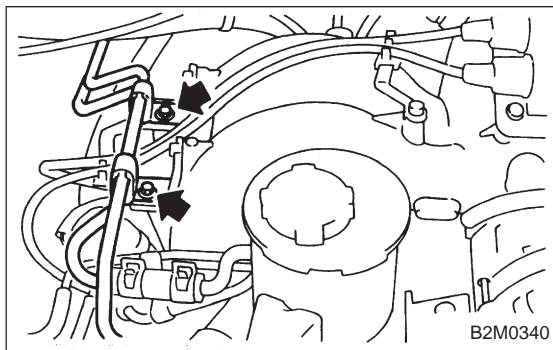

(2) Install power steering pipe bracket on right side intake manifold.

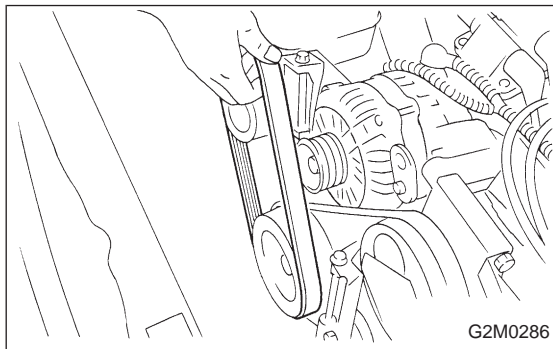

(3) Install front side V-belt, and adjust it.  
<Ref. to 1-5 [01A0].>

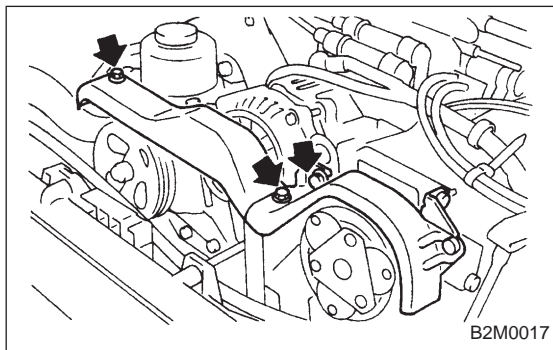

(4) Install V-belt cover.

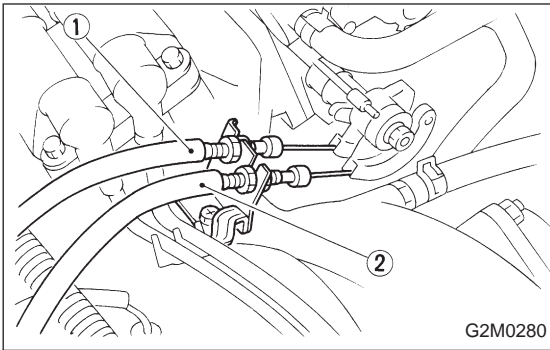

- 16) Connect accelerator cable ①.
- 17) Connect cruise control cable ②. (With cruise control model)

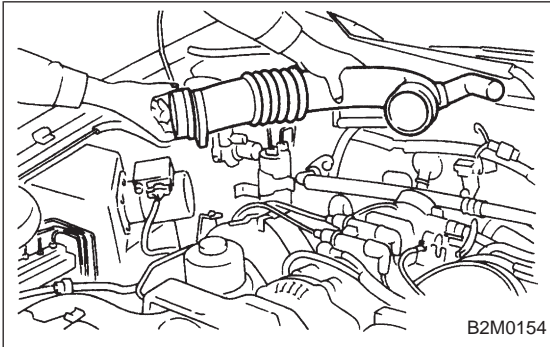

- 18) Install air cleaner element, air cleaner upper cover and air intake duct.
- 19) Connect connector to mass air flow sensor.

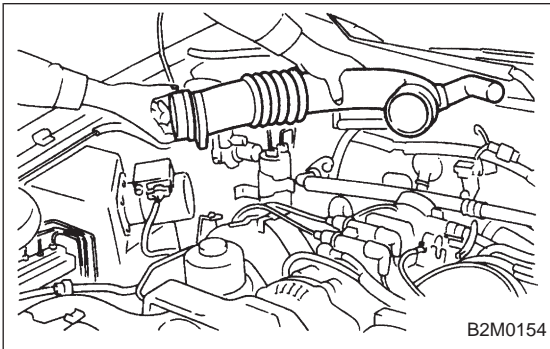

## 5. Engine Coolant Temperature Sensor

### A: REMOVAL AND INSTALLATION

- 1) Remove air intake duct.

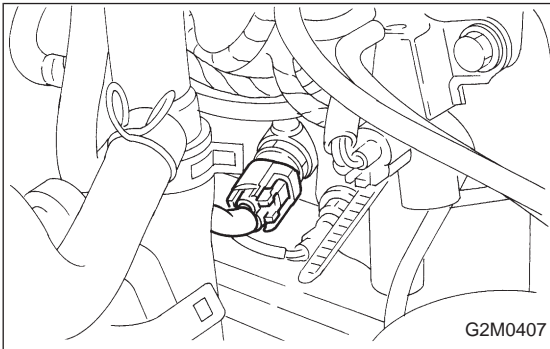

- 2) Disconnect connector from engine coolant temperature sensor.
- 3) Remove engine coolant temperature sensor.

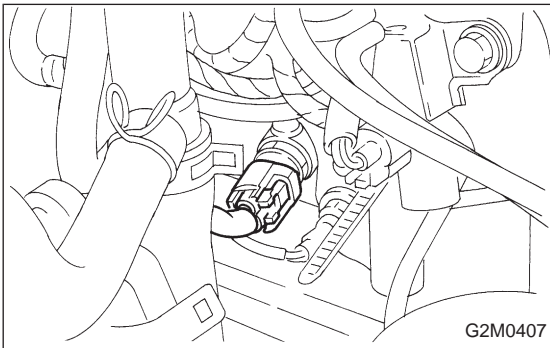

- 4) Installation is in the reverse order of removal.

#### **Tightening torque:**

**25±3 N·m (2.5±0.3 kg·m, 18.1±2.2 ft·lb)**

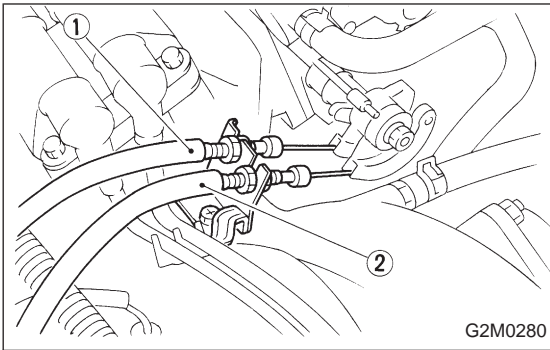

- 16) Connect accelerator cable ①.
- 17) Connect cruise control cable ②. (With cruise control model)

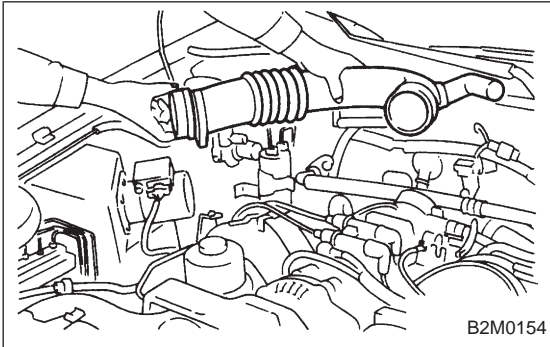

- 18) Install air cleaner element, air cleaner upper cover and air intake duct.
- 19) Connect connector to mass air flow sensor.

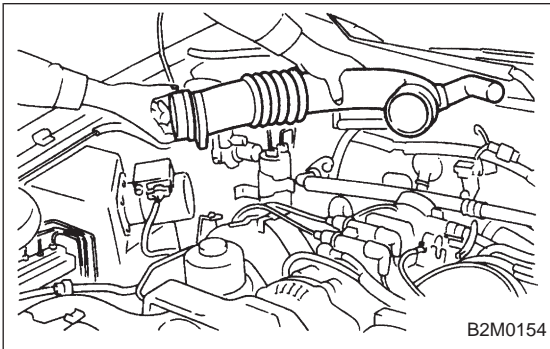

## 5. Engine Coolant Temperature Sensor

### A: REMOVAL AND INSTALLATION

- 1) Remove air intake duct.

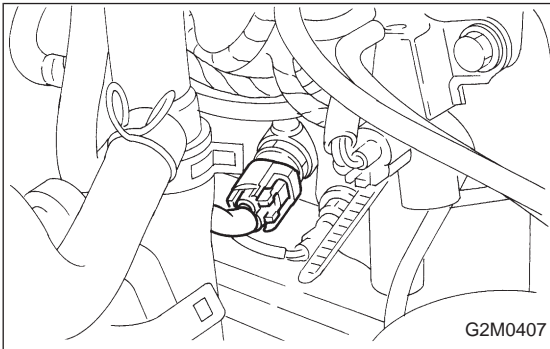

- 2) Disconnect connector from engine coolant temperature sensor.
- 3) Remove engine coolant temperature sensor.

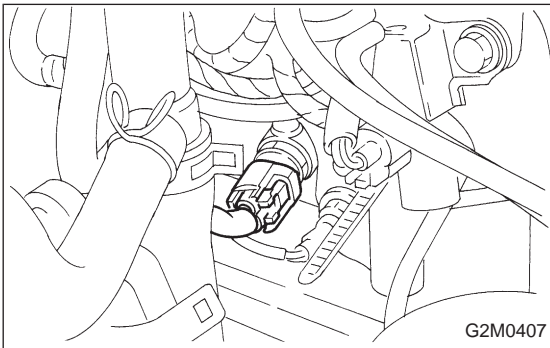

- 4) Installation is in the reverse order of removal.

#### **Tightening torque:**

**25±3 N·m (2.5±0.3 kg·m, 18.1±2.2 ft·lb)**

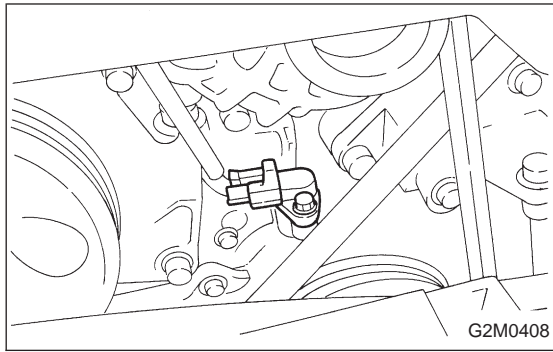

## 6. Crankshaft Position Sensor

### A: REMOVAL AND INSTALLATION

1) Remove bolt which install crankshaft position sensor to cylinder block.

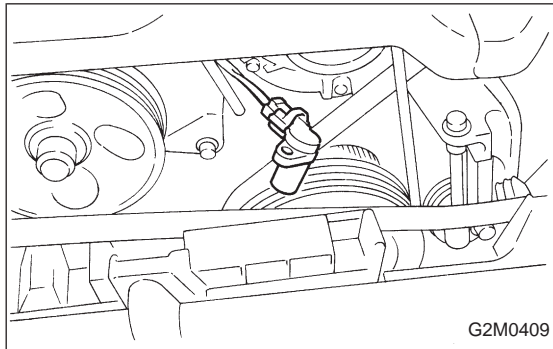

2) Remove crankshaft position sensor, and disconnect connector from it.

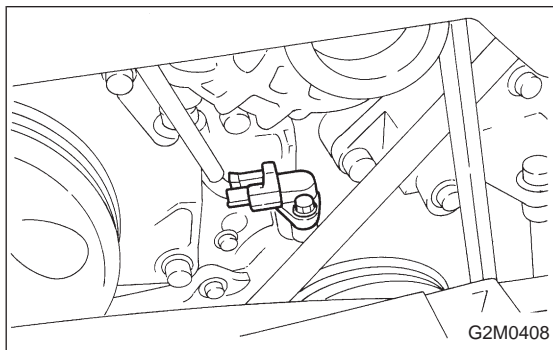

3) Installation is in the reverse order of removal.

#### **Tightening torque:**

**$6.4 \pm 0.5 \text{ N}\cdot\text{m}$  ( $0.65 \pm 0.05 \text{ kg}\cdot\text{m}$ ,  $4.7 \pm 0.4 \text{ ft}\cdot\text{lb}$ )**

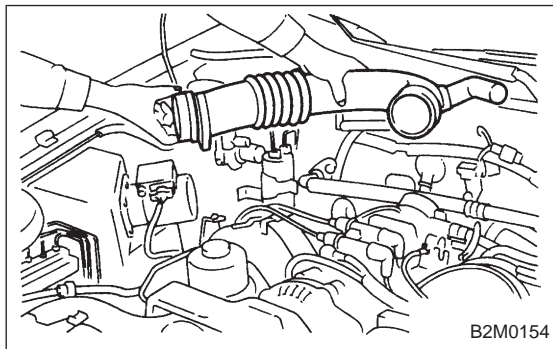

## 7. Front Oxygen Sensor

### A: REMOVAL

1) Remove air intake duct.

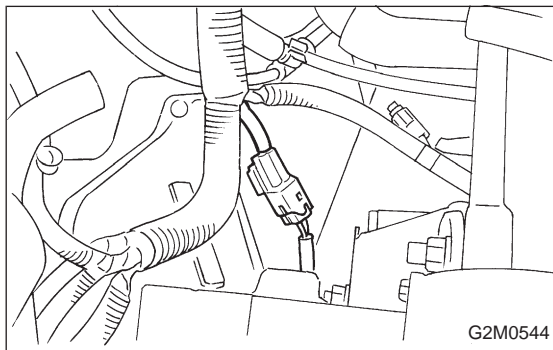

2) Disconnect connector from front oxygen sensor.

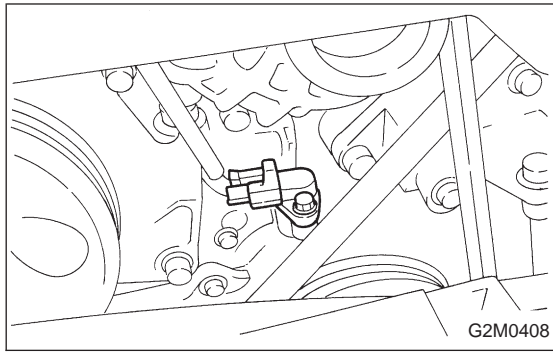

## 6. Crankshaft Position Sensor

### A: REMOVAL AND INSTALLATION

1) Remove bolt which install crankshaft position sensor to cylinder block.

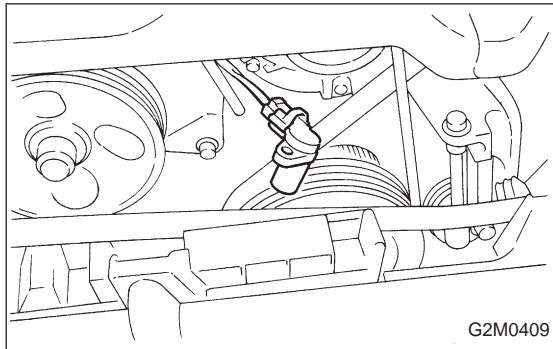

2) Remove crankshaft position sensor, and disconnect connector from it.

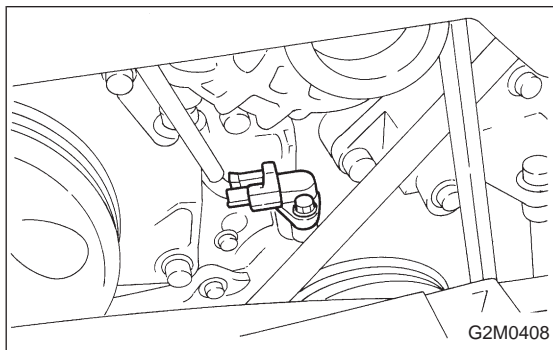

3) Installation is in the reverse order of removal.

#### **Tightening torque:**

**$6.4 \pm 0.5 \text{ N}\cdot\text{m}$  ( $0.65 \pm 0.05 \text{ kg}\cdot\text{m}$ ,  $4.7 \pm 0.4 \text{ ft}\cdot\text{lb}$ )**

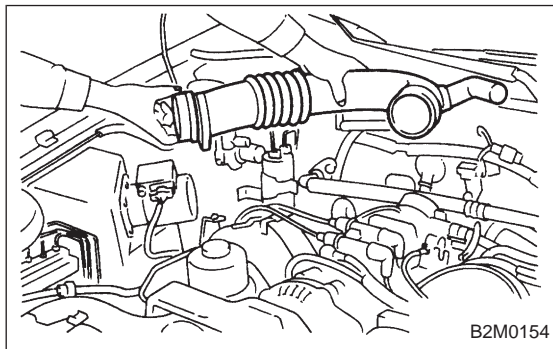

## 7. Front Oxygen Sensor

### A: REMOVAL

1) Remove air intake duct.

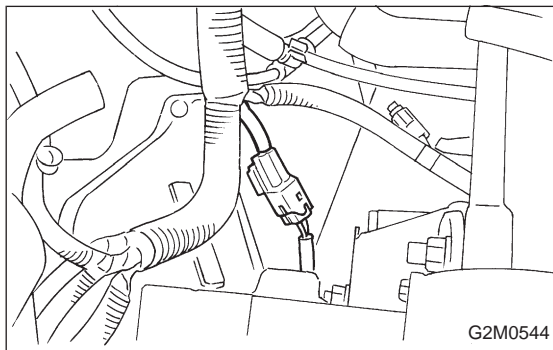

2) Disconnect connector from front oxygen sensor.

- 3) Lift-up the vehicle.
- 4) Apply SUBARU CRC or its equivalent to threaded portion of front oxygen sensor, and leave it for one minute or more.

***SUBARU CRC (Part No. 004301003)***

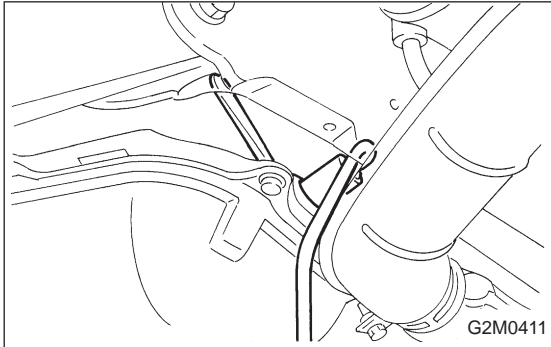

- 5) Remove front oxygen sensor.

**CAUTION:**

**When removing oxygen sensor, do not force oxygen sensor especially when exhaust pipe is cold, otherwise it will damage exhaust pipe.**

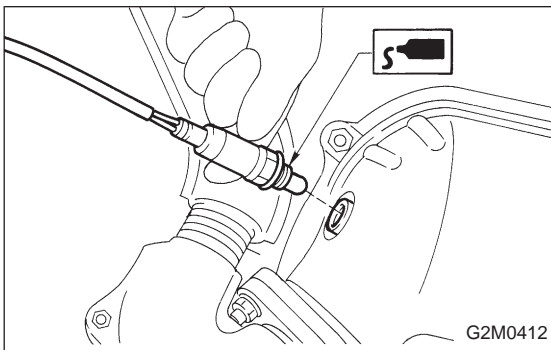

**B: INSTALLATION**

- 1) Before installing front oxygen sensor, apply anti-seize compound only to threaded portion of front oxygen sensor to make the next removal easier.

***Anti-seize compound:***

***SS-30 by JET LUBE***

**CAUTION:**

**Never apply anti-seize compound to protector of front oxygen sensor.**

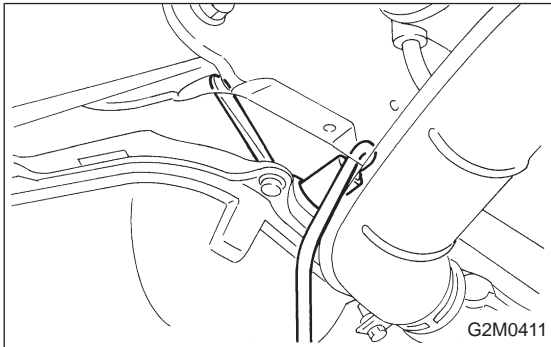

- 2) Install front oxygen sensor.

***Tightening torque:***

***21±3 N·m (2.1±0.3 kg·m, 15.2±2.2 ft·lb)***

- 3) Lower the vehicle.
- 4) Connect connector of front oxygen sensor.
- 5) Install air intake duct.



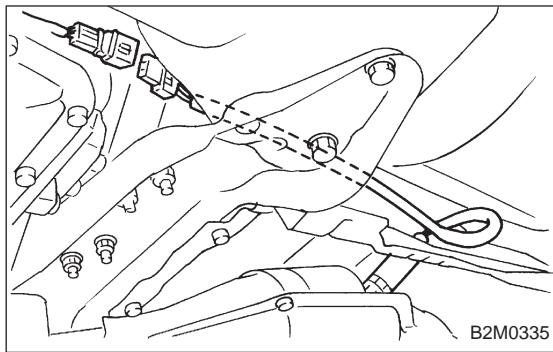

## 8. Rear Oxygen Sensor

### A: REMOVAL

- 1) Lift-up the vehicle.
- 2) Disconnect connector from rear oxygen sensor.

- 3) Apply SUBARU CRC or its equivalent to threaded portion of rear oxygen sensor, and leave it for one minute or more.

**SUBARU CRC (Part No. 004301003)**

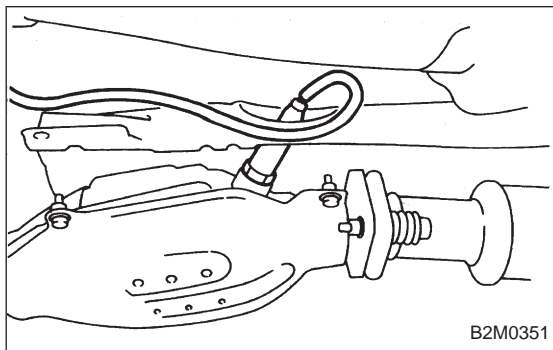

- 4) Remove rear oxygen sensor.

#### CAUTION:

**When removing rear oxygen sensor, do not force rear oxygen sensor especially when exhaust pipe is cold, otherwise it will damage exhaust pipe.**

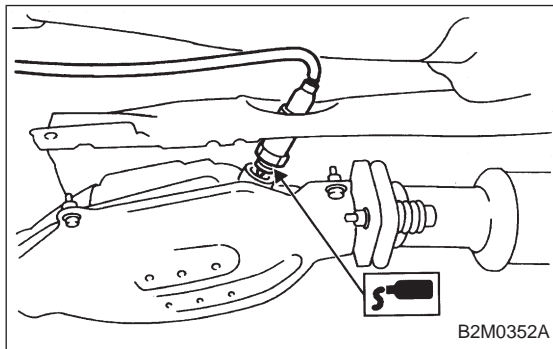

### B: INSTALLATION

- 1) Before installing rear oxygen sensor, apply anti-seize compound only to threaded portion of rear oxygen sensor to make the next removal easier.

#### Anti-seize compound:

**SS-30 by JET LUBE**

#### CAUTION:

**Never apply anti-seize compound to protector of rear oxygen sensor.**

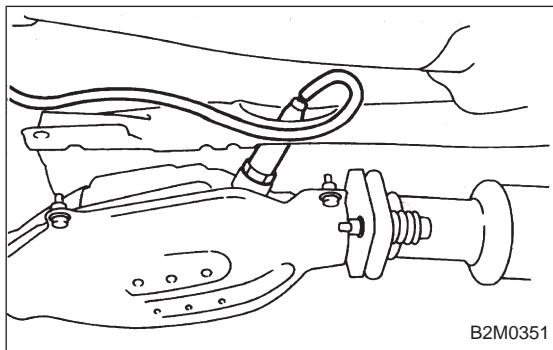

- 2) Install rear oxygen sensor.

#### Tightening torque:

**21±3 N·m (2.1±0.3 kg·m, 15.2±2.2 ft·lb)**

- 3) Connect connector of rear oxygen sensor.
- 4) Lower the vehicle.

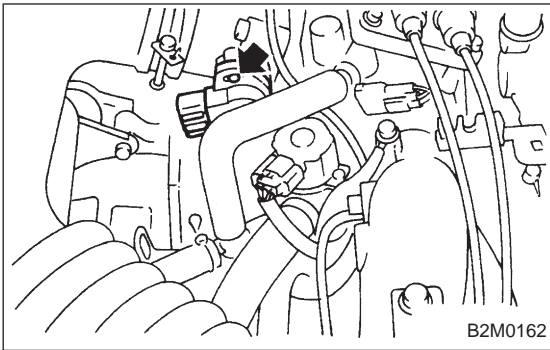

B2M0162

## 9. Throttle Position Sensor

### A: REMOVAL AND INSTALLATION

- 1) Disconnect connector from throttle position sensor.
- 2) Remove throttle position sensor holding screws, and remove it.
- 3) Installation is in the reverse order of removal.

#### **Tightening torque:**

**$2.2 \pm 0.2 \text{ N}\cdot\text{m}$  ( $0.22 \pm 0.02 \text{ kg}\cdot\text{m}$ ,  $1.6 \pm 0.1 \text{ ft}\cdot\text{lb}$ )**

#### **CAUTION:**

**When installing throttle position sensor, adjust to the specified data.**

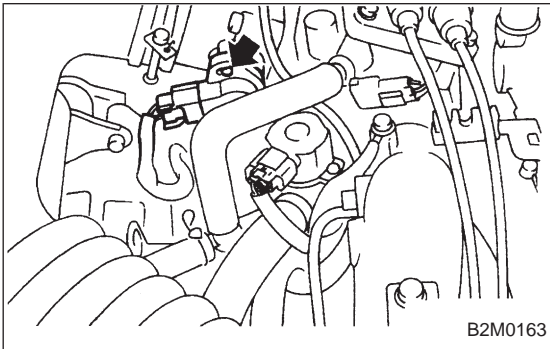

B2M0163

### B: ADJUSTMENT

- 1) Turn ignition switch to OFF.
- 2) Loosen throttle position sensor holding screws.

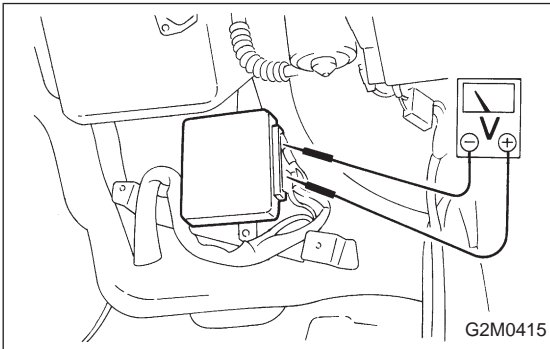

G2M0415

- 3) When using voltage meter;
  - (1) Take out ECM.
  - (2) Turn ignition switch to ON.
  - (3) Adjust throttle position sensor so that signal voltage to ECM may be in specification.

**Connector & Terminal / Specified voltage**  
**(B84) No. 24 — (B84) No. 25 / 0.45 — 0.55 V**  
**[Fully closed.]**

- (4) Tighten throttle position sensor holding screws.

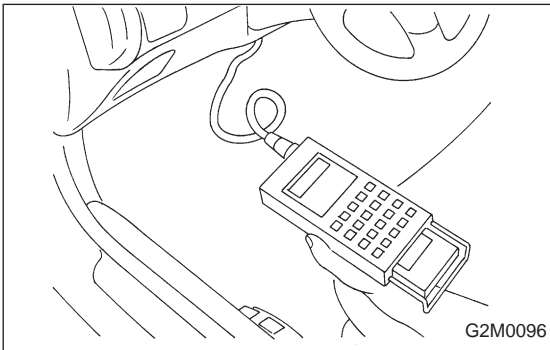

G2M0096

- 4) When using Subaru Select Monitor;
  - (1) Connect Subaru Select Monitor to the data link connector.
  - (2) Turn ignition switch to ON and SSM switch to ON.
  - (3) Select mode "F10".
  - (4) Adjust throttle position sensor to specified data.

**Condition / Specified data.**  
**Throttle fully closed / 0.50 V**

- (5) Tighten throttle position sensor holding screws.

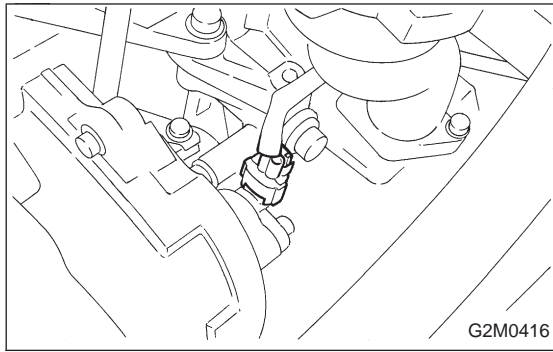

## 10. Camshaft Position Sensor

### A: REMOVAL AND INSTALLATION

1) Disconnect connector from camshaft position sensor.

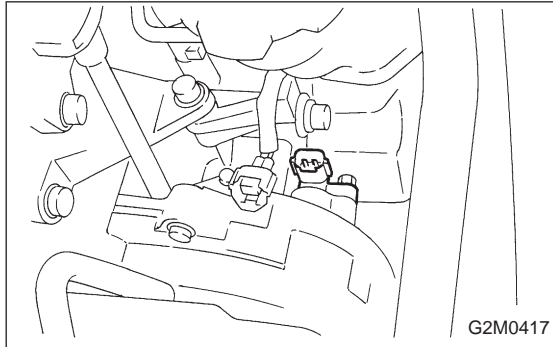

2) Remove camshaft position sensor from camshaft support LH.

3) Installation is in the reverse order of removal.

#### **Tightening torque:**

**$6.4 \pm 0.5 \text{ N}\cdot\text{m}$  ( $0.65 \pm 0.05 \text{ kg}\cdot\text{m}$ ,  $4.7 \pm 0.4 \text{ ft}\cdot\text{lb}$ )**

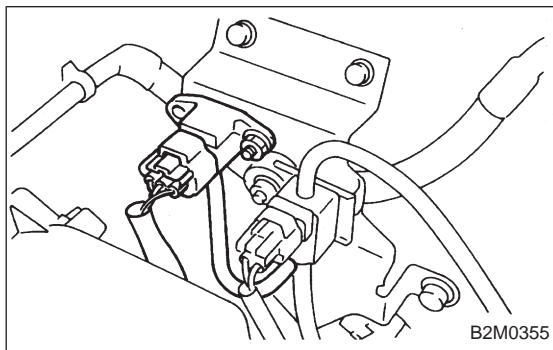

## 11. Pressure Sensor (AT model)

### A: REMOVAL AND INSTALLATION

1) Disconnect connector from pressure sensor.

2) Disconnect hose from pressure sensor.

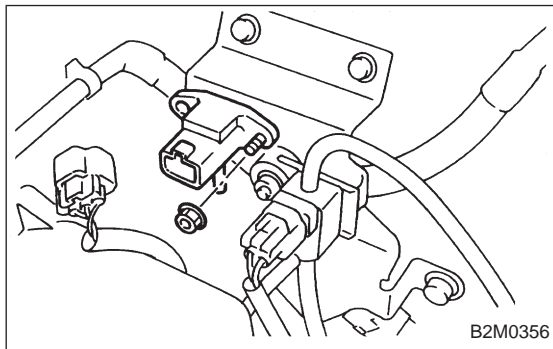

3) Remove pressure sensor from bracket.

4) Installation is in the reverse order of removal.

#### **Tightening torque:**

**$6.4 \pm 0.5 \text{ N}\cdot\text{m}$  ( $0.65 \pm 0.05 \text{ kg}\cdot\text{m}$ ,  $4.7 \pm 0.4 \text{ ft}\cdot\text{lb}$ )**

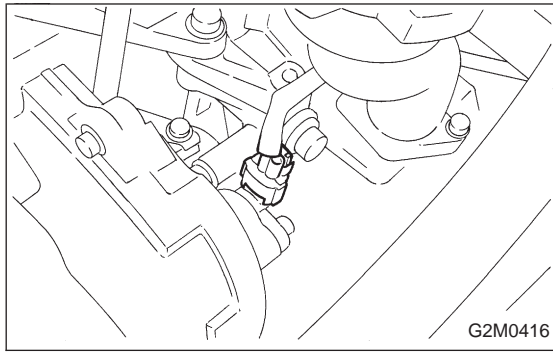

## 10. Camshaft Position Sensor

### A: REMOVAL AND INSTALLATION

1) Disconnect connector from camshaft position sensor.

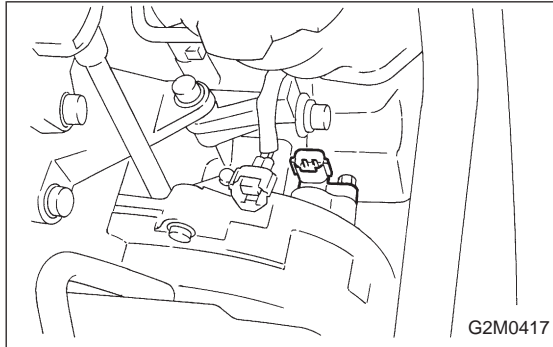

2) Remove camshaft position sensor from camshaft support LH.

3) Installation is in the reverse order of removal.

#### **Tightening torque:**

**$6.4 \pm 0.5 \text{ N}\cdot\text{m}$  ( $0.65 \pm 0.05 \text{ kg}\cdot\text{m}$ ,  $4.7 \pm 0.4 \text{ ft}\cdot\text{lb}$ )**

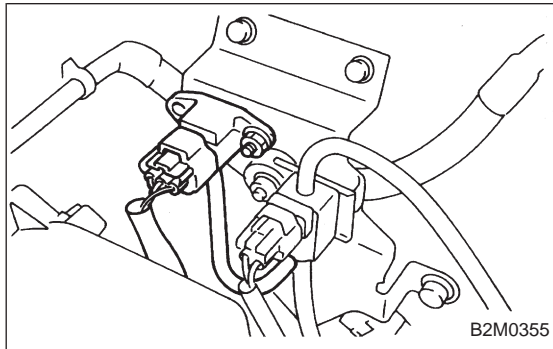

## 11. Pressure Sensor (AT model)

### A: REMOVAL AND INSTALLATION

1) Disconnect connector from pressure sensor.

2) Disconnect hose from pressure sensor.

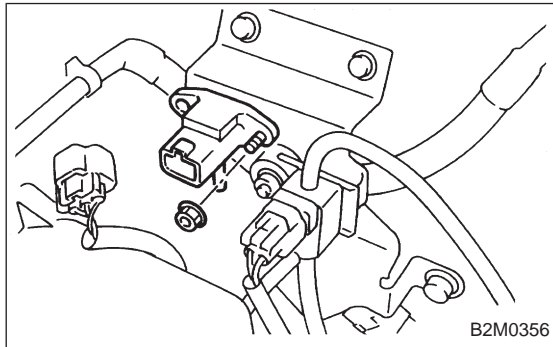

3) Remove pressure sensor from bracket.

4) Installation is in the reverse order of removal.

#### **Tightening torque:**

**$6.4 \pm 0.5 \text{ N}\cdot\text{m}$  ( $0.65 \pm 0.05 \text{ kg}\cdot\text{m}$ ,  $4.7 \pm 0.4 \text{ ft}\cdot\text{lb}$ )**

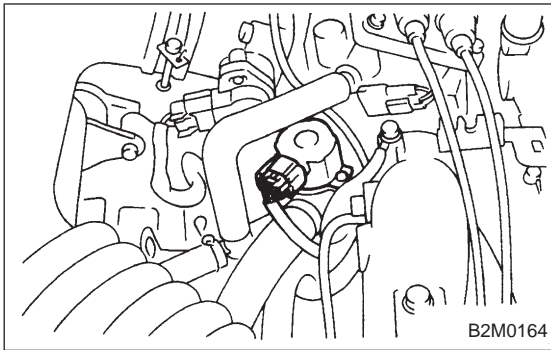

## 12. Idle Air Control Solenoid Valve

### A: REMOVAL AND INSTALLATION

1) Disconnect connector from idle air control solenoid valve.

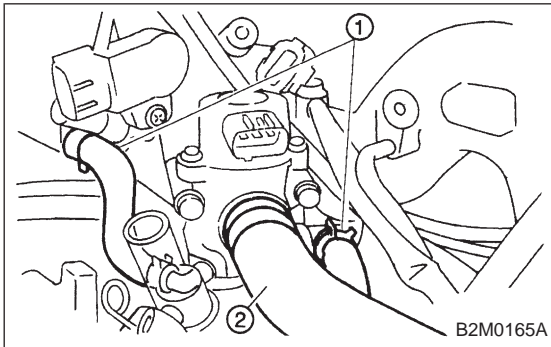

2) Disconnect engine coolant hoses ① from idle air control solenoid valve.

3) Disconnect air by-pass hose ② from idle air control solenoid valve.

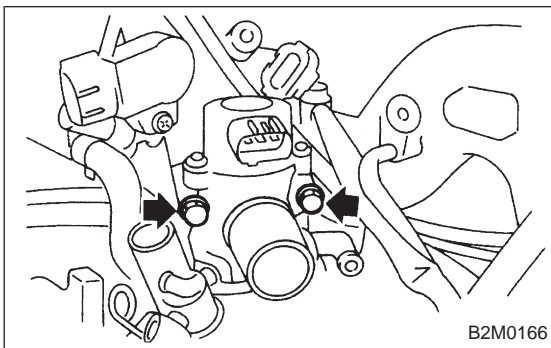

4) Remove idle air control solenoid valve from throttle body.

5) Installation is in the reverse order of removal.

#### CAUTION:

Replace gasket with a new one.

#### Tightening torque:

$6.4 \pm 0.5 \text{ N}\cdot\text{m}$  ( $0.65 \pm 0.05 \text{ kg}\cdot\text{m}$ ,  $4.7 \pm 0.4 \text{ ft}\cdot\text{lb}$ )

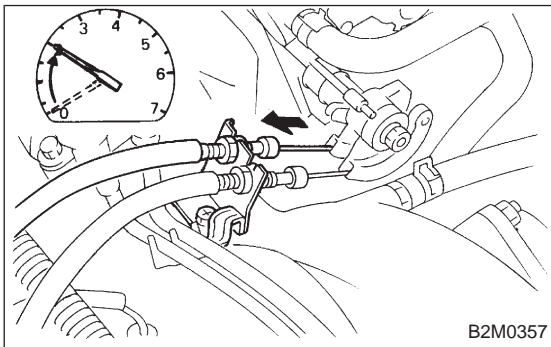

### B: CLEANING

1) Start and warm-up the engine until radiator fan operates.

2) Hold throttle valve so that engine speed is at 2,000 rpm.

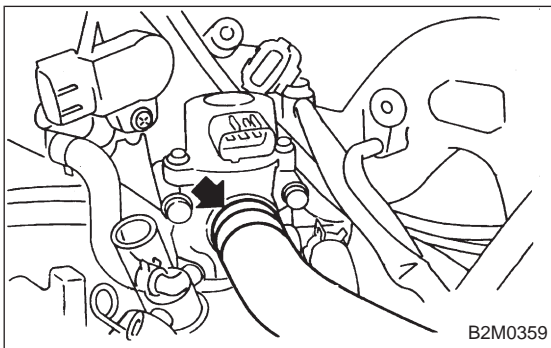

3) Disconnect by-pass hose from idle air control solenoid valve.

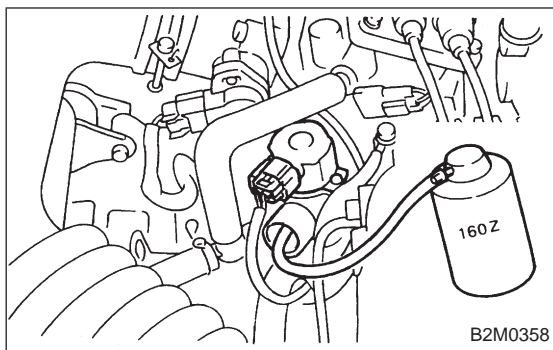

4) Slowly pour one can (16 oz) of cleaner into by-pass air hole.

**Cleaner:**

- **Part No. 1050002 GM Top Engine Cleaner**
- **Part No. X66-A AC Delco Carburetor Tune-up Conditioner**

5) Leave the engine running for five minutes.

**NOTE:**

White smoke comes out of the muffler until the cleaner is used up.

6) Stop the engine.

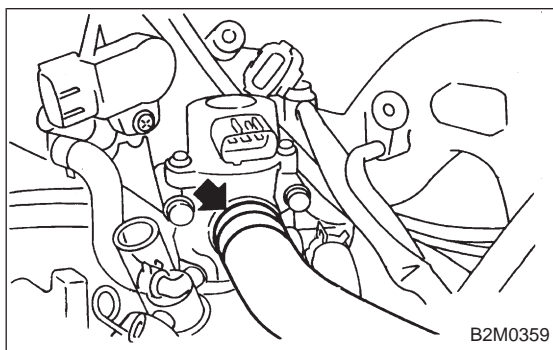

7) Release the throttle valve.

8) Connect by-pass hose to idle air control solenoid valve.

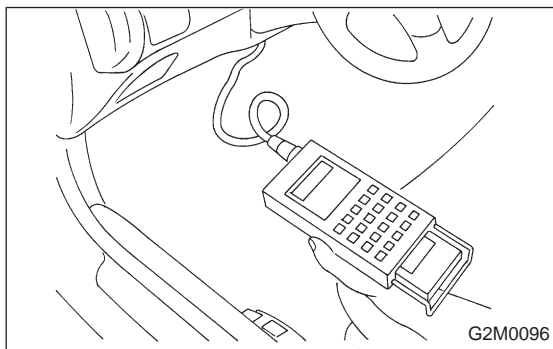

9) Check duty ratio of idle air control solenoid valve with Subaru Select Monitor.

- (1) Connect Subaru Select Monitor to the data link connector.
- (2) Start the engine and turn Subaru Select Monitor switch to ON.
- (3) Select mode "F12".
- (4) Make sure duty ratio on radiator fan and electric load is OFF.

**Specified data: 25 — 40%**

## 13. Pressure Sources Switching Solenoid Valve (AT model)

### A: REMOVAL AND INSTALLATION

- 1) Disconnect connector from pressure sources switching solenoid valve.
- 2) Disconnect hoses from pressure sources switching solenoid valve.

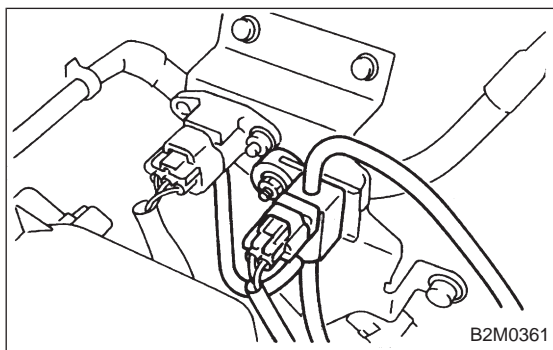

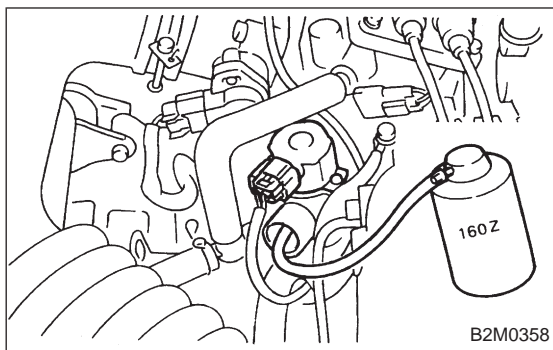

4) Slowly pour one can (16 oz) of cleaner into by-pass air hole.

**Cleaner:**

- Part No. 1050002 GM Top Engine Cleaner
- Part No. X66-A AC Delco Carburetor Tune-up Conditioner

5) Leave the engine running for five minutes.

**NOTE:**

White smoke comes out of the muffler until the cleaner is used up.

6) Stop the engine.

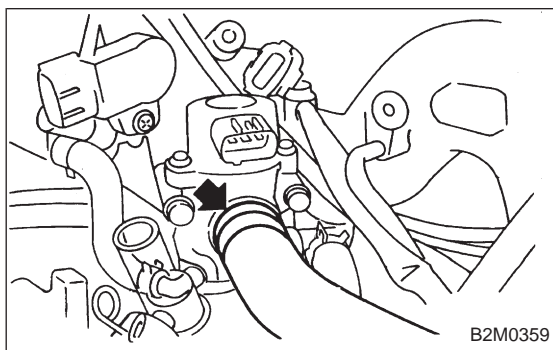

7) Release the throttle valve.

8) Connect by-pass hose to idle air control solenoid valve.

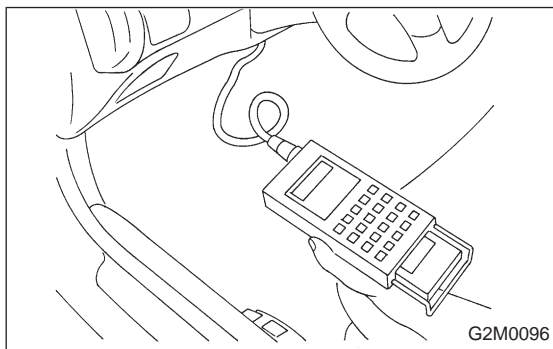

9) Check duty ratio of idle air control solenoid valve with Subaru Select Monitor.

- (1) Connect Subaru Select Monitor to the data link connector.
- (2) Start the engine and turn Subaru Select Monitor switch to ON.
- (3) Select mode "F12".
- (4) Make sure duty ratio on radiator fan and electric load is OFF.

**Specified data: 25 — 40%**

## 13. Pressure Sources Switching Solenoid Valve (AT model)

### A: REMOVAL AND INSTALLATION

- 1) Disconnect connector from pressure sources switching solenoid valve.
- 2) Disconnect hoses from pressure sources switching solenoid valve.

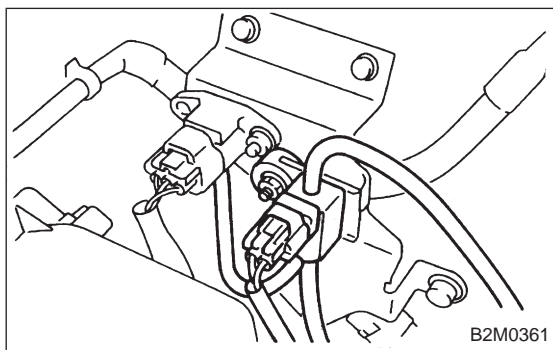

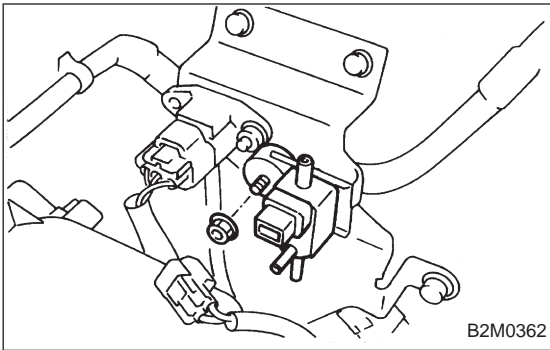

- 3) Remove pressure sources switching solenoid valve from bracket.
- 4) Installation is in the reverse order of removal.

**Tightening torque:**

**$6.4 \pm 0.5 \text{ N}\cdot\text{m}$  ( $0.65 \pm 0.05 \text{ kg}\cdot\text{m}$ ,  $4.7 \pm 0.4 \text{ ft}\cdot\text{lb}$ )**

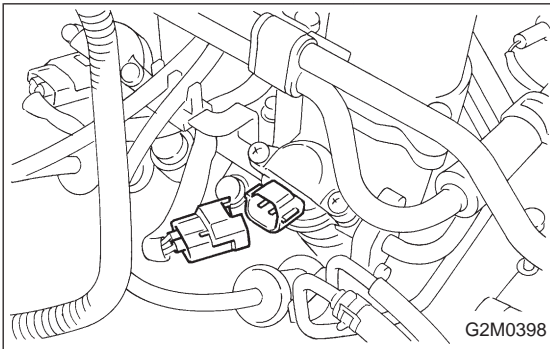

**14. Fuel Injector**

**A: REMOVAL AND INSTALLATION**

- 1) Release fuel pressure.  
<Ref. to 2-8 [W1A0].>
- 2) Disconnect connector from fuel injector.

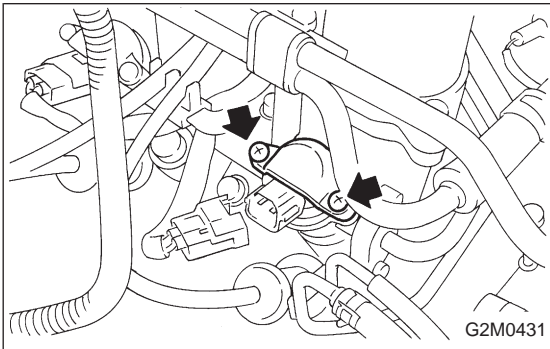

- 3) Remove fuel injector from fuel pipe assembly.

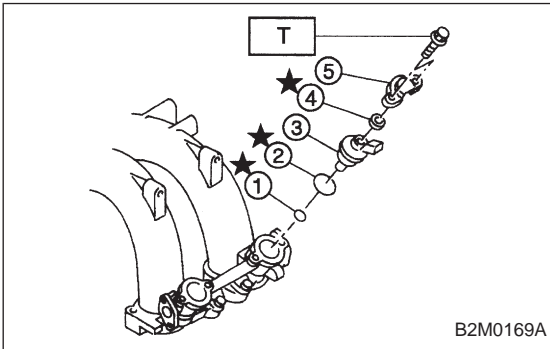

- 4) Installation is in the reverse order of removal.

**CAUTION:**

**Replace O-rings and insulator.**

**Tightening torque:**

**$T: 3.4 \pm 0.5 \text{ N}\cdot\text{m}$  ( $0.35 \pm 0.05 \text{ kg}\cdot\text{m}$ ,  $2.5 \pm 0.4 \text{ ft}\cdot\text{lb}$ )**

- ① O-ring B
- ② O-ring A
- ③ Fuel injector
- ④ Insulator
- ⑤ Fuel injector cup

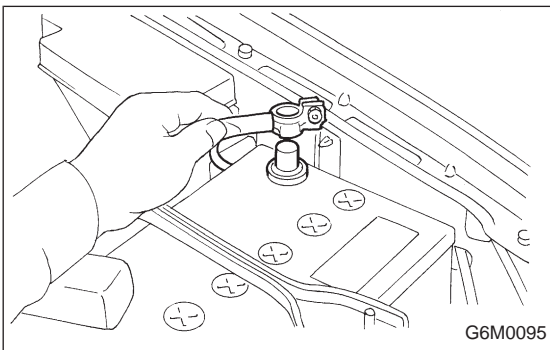

**15. Engine Control Module**

**A: REMOVAL AND INSTALLATION**

- 1) Disconnect battery ground cable.



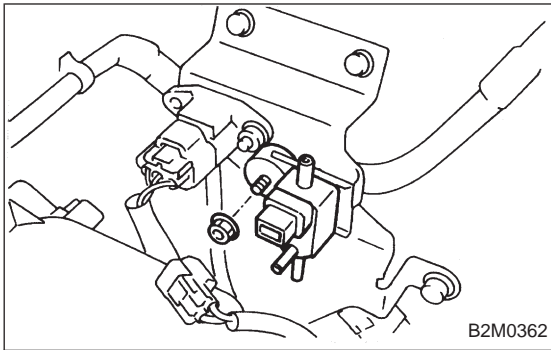

- 3) Remove pressure sources switching solenoid valve from bracket.
- 4) Installation is in the reverse order of removal.

**Tightening torque:**

**$6.4 \pm 0.5 \text{ N}\cdot\text{m}$  ( $0.65 \pm 0.05 \text{ kg}\cdot\text{m}$ ,  $4.7 \pm 0.4 \text{ ft}\cdot\text{lb}$ )**

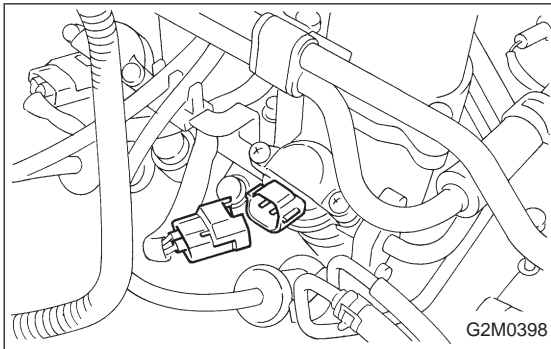

## 14. Fuel Injector

### A: REMOVAL AND INSTALLATION

- 1) Release fuel pressure.  
<Ref. to 2-8 [W1A0].>
- 2) Disconnect connector from fuel injector.

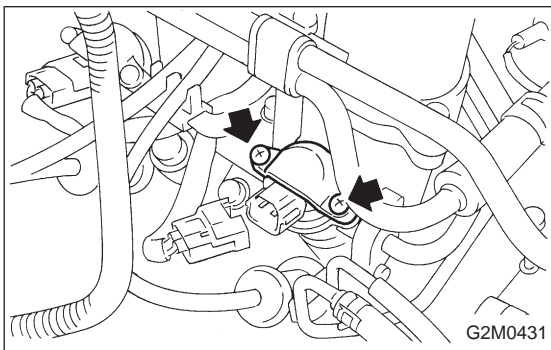

- 3) Remove fuel injector from fuel pipe assembly.

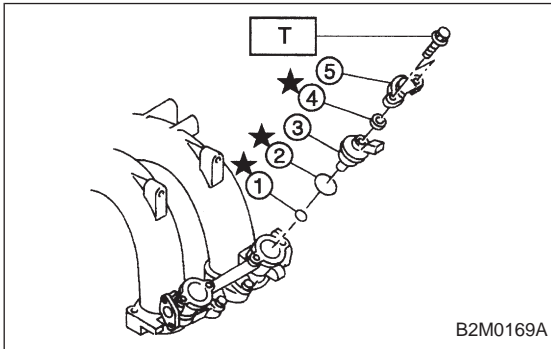

- 4) Installation is in the reverse order of removal.

**CAUTION:**

**Replace O-rings and insulator.**

**Tightening torque:**

**$T: 3.4 \pm 0.5 \text{ N}\cdot\text{m}$  ( $0.35 \pm 0.05 \text{ kg}\cdot\text{m}$ ,  $2.5 \pm 0.4 \text{ ft}\cdot\text{lb}$ )**

- ① O-ring B
- ② O-ring A
- ③ Fuel injector
- ④ Insulator
- ⑤ Fuel injector cup

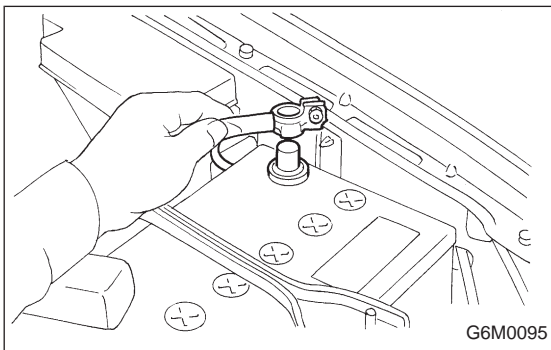

## 15. Engine Control Module

### A: REMOVAL AND INSTALLATION

- 1) Disconnect battery ground cable.

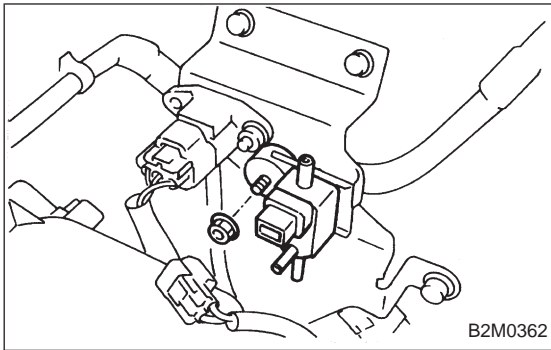

- 3) Remove pressure sources switching solenoid valve from bracket.
- 4) Installation is in the reverse order of removal.

**Tightening torque:**

**$6.4 \pm 0.5 \text{ N}\cdot\text{m}$  ( $0.65 \pm 0.05 \text{ kg}\cdot\text{m}$ ,  $4.7 \pm 0.4 \text{ ft}\cdot\text{lb}$ )**

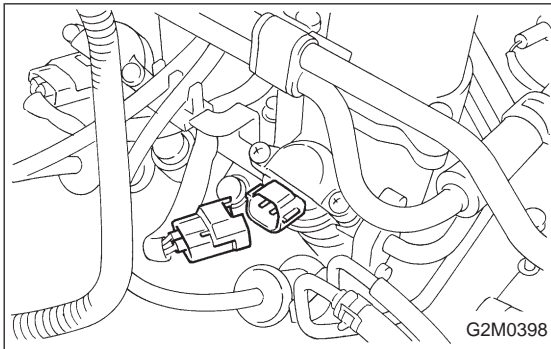

## 14. Fuel Injector

### A: REMOVAL AND INSTALLATION

- 1) Release fuel pressure.  
<Ref. to 2-8 [W1A0].>
- 2) Disconnect connector from fuel injector.

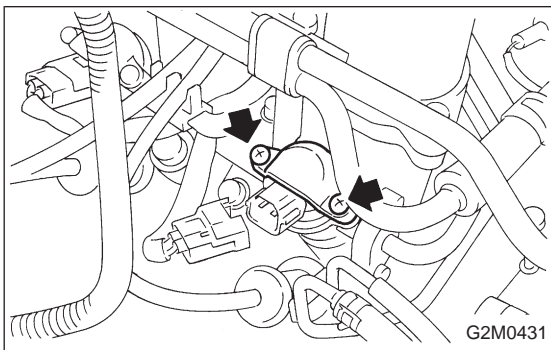

- 3) Remove fuel injector from fuel pipe assembly.

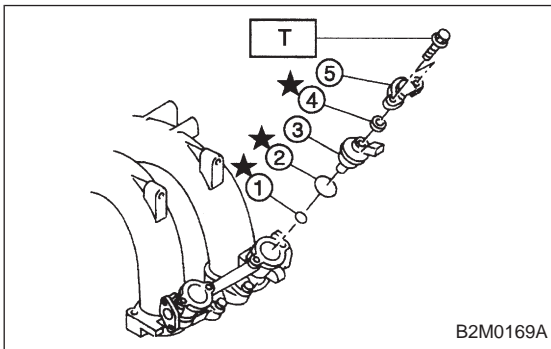

- 4) Installation is in the reverse order of removal.

**CAUTION:**

**Replace O-rings and insulator.**

**Tightening torque:**

**$T: 3.4 \pm 0.5 \text{ N}\cdot\text{m}$  ( $0.35 \pm 0.05 \text{ kg}\cdot\text{m}$ ,  $2.5 \pm 0.4 \text{ ft}\cdot\text{lb}$ )**

- ① O-ring B
- ② O-ring A
- ③ Fuel injector
- ④ Insulator
- ⑤ Fuel injector cup

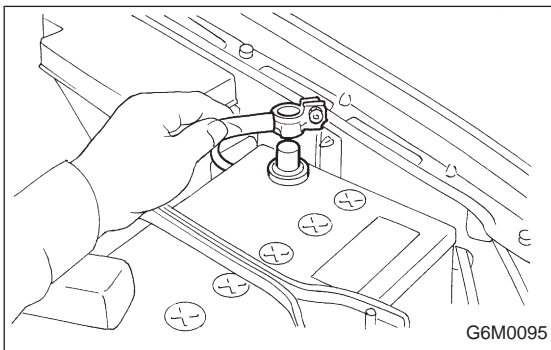

## 15. Engine Control Module

### A: REMOVAL AND INSTALLATION

- 1) Disconnect battery ground cable.

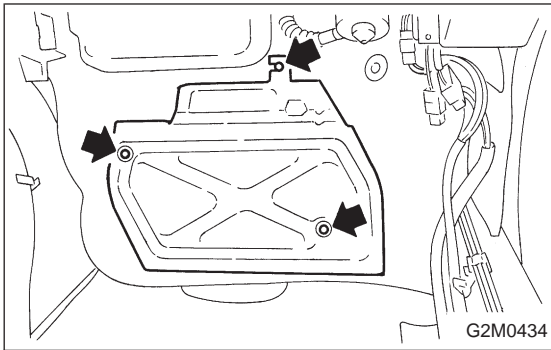

- 2) Detach floor mat of front passenger seat.
- 3) Remove protect cover.

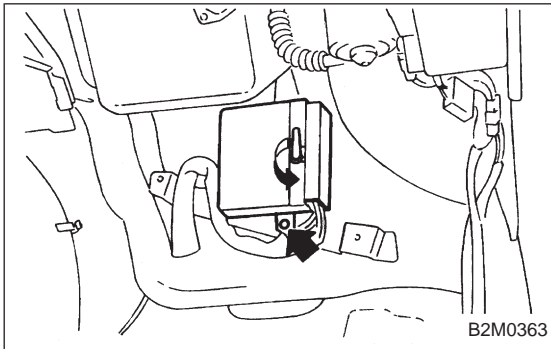

- 4) Release the lock of ECM connector and disconnect it.
- 5) Remove nuts which install ECM onto body.
- 6) Take out ECM.

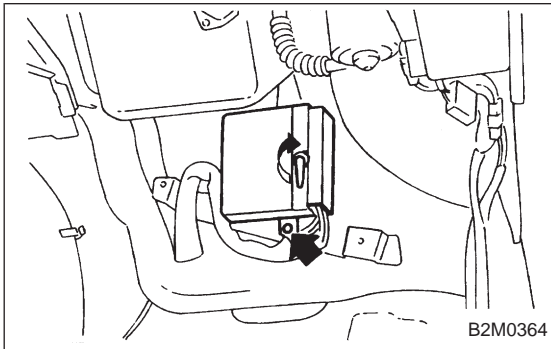

- 7) Connect ECM connector and lock it.
- 8) Installation is in the reverse order of removal.

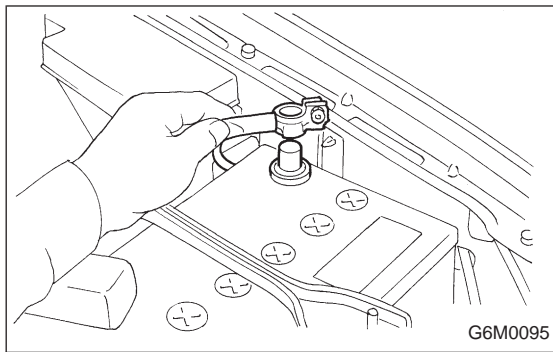

## 16. Main Relay

### A: REMOVAL AND INSTALLATION

1) Disconnect battery ground cable.

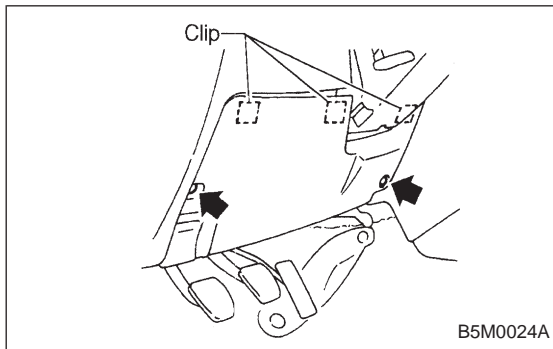

2) Remove lower cover and then disconnect connectors.

3) Lower transmission control module.

4) Remove the front pillar lower trim.

<Ref. to 5-3 [W5A1].>

5) Remove fuse box mounting nuts.

6) Lower fuse box.

7) Remove fuse box mounting bracket.

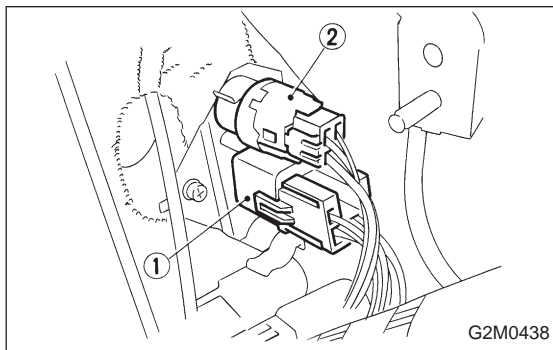

8) Remove screw which retains bracket of main relay ① and fuel pump relay ②.

9) Disconnect connector from main relay.

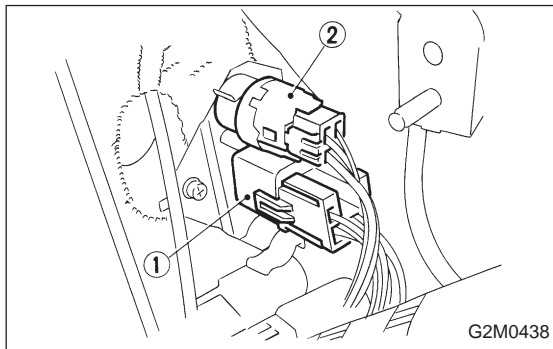

10) Installation is in the reverse order of removal.

① Main relay

② Fuel pump relay

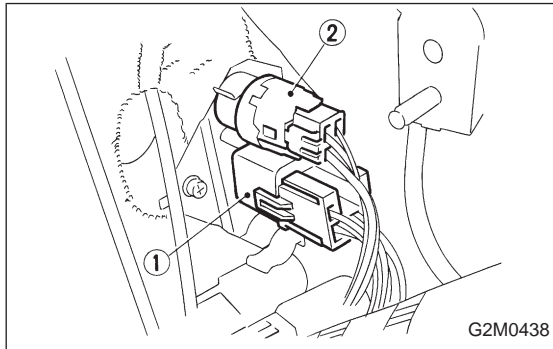
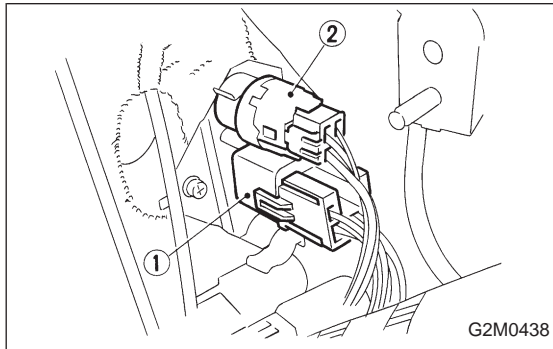
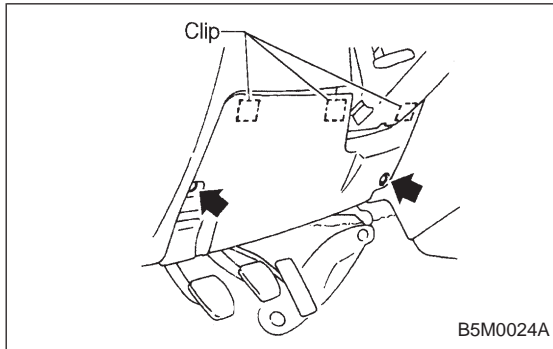
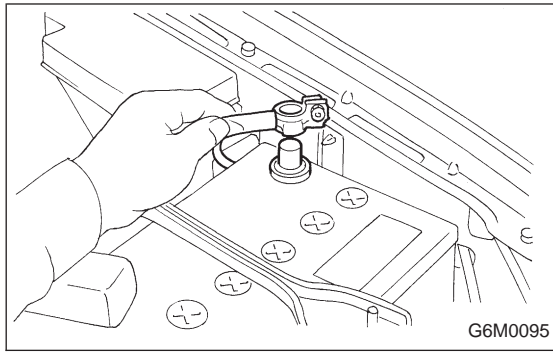

## 17. Fuel Pump Relay

### A: REMOVAL AND INSTALLATION

- 1) Disconnect battery ground cable.
- 2) Remove lower cover and then disconnect connectors.
- 3) Lower transmission control module.
- 4) Remove the front pillar lower trim.  
<Ref. to 5-3 [W5A1].>
- 5) Remove fuse box mounting nuts.
- 6) Lower fuse box.
- 7) Remove fuse box mounting bracket.
- 8) Remove fuel pump relay from main relay and fuel pump relay mounting bracket.
- 9) Disconnect connector from fuel pump relay.
- 10) Installation is in the reverse order of removal.
  - ① Main relay
  - ② Fuel pump relay

**1. Fuel System****A: SPECIFICATIONS**

Fuel tank	Capacity	60 ℓ (15.9 US gal, 13.2 Imp gal)
	Location	Under rear seat
Fuel pump	Type	Impeller
	Discharge pressure	250.1 kPa (2.55 kg/cm <sup>2</sup> , 36.3 psi)
	Discharge flow	AWD: More than 80 ℓ (21.1 US gal, 17.6 Imp gal)/h FWD: More than 65 ℓ (17.2 US gal, 14.3 Imp gal)/h [12 V at 300 kPa (3.06 kg/cm <sup>2</sup> , 43.5 psi)]
Fuel filter		Cartridge type

1. Fuel Tank

1. AWD MODEL

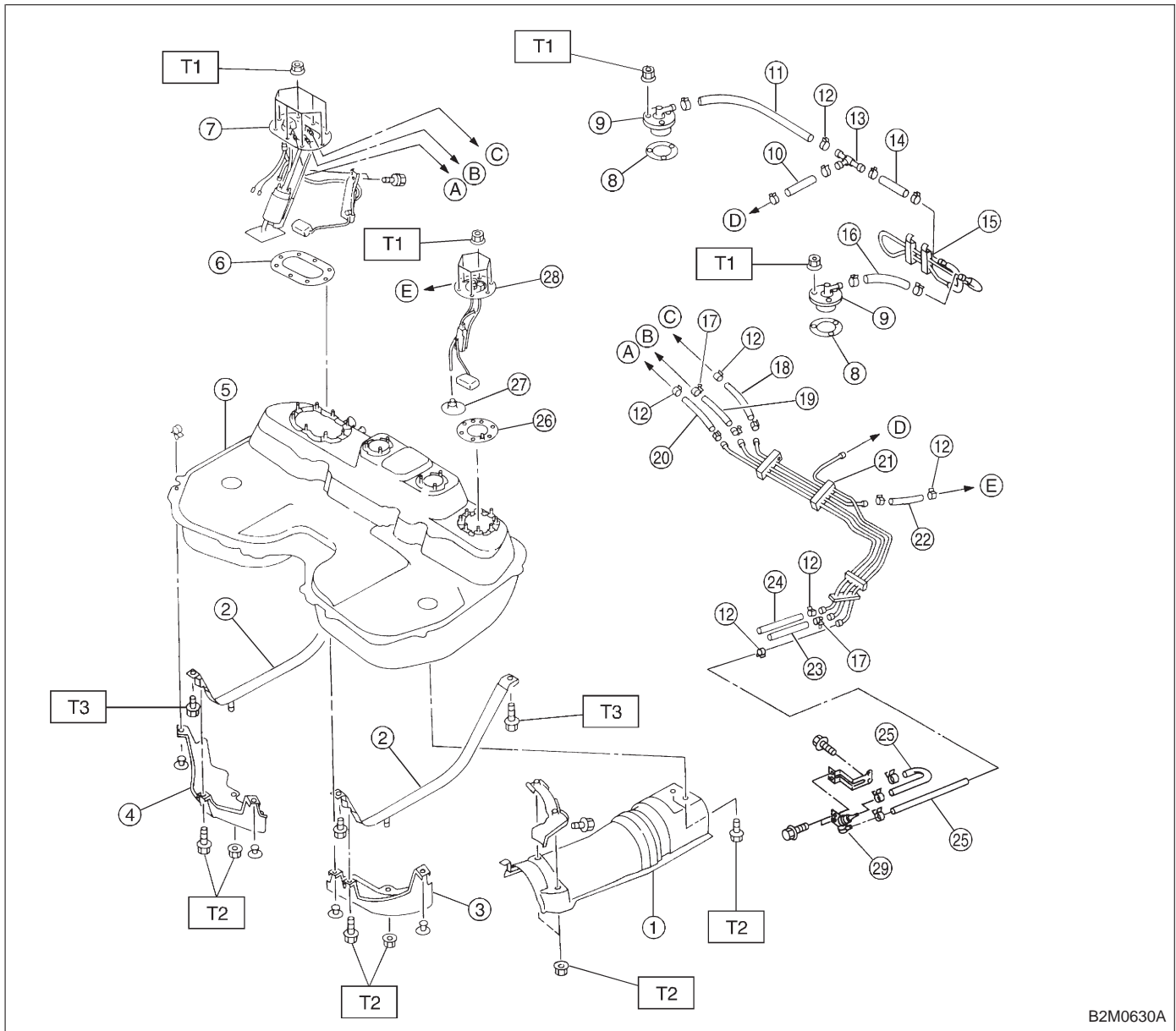

B2M0630A

- ① Heat sealed cover
- ② Fuel tank band
- ③ Protector LH
- ④ Protector RH
- ⑤ Fuel tank
- ⑥ Fuel pump gasket
- ⑦ Fuel pump ASSY
- ⑧ Fuel cut valve gasket
- ⑨ Fuel cut valve
- ⑩ Evaporation hose C
- ⑪ Evaporation hose A

- ⑫ Clip
- ⑬ Joint pipe
- ⑭ Evaporation hose B
- ⑮ Evaporation pipe ASSY
- ⑯ Evaporation hose D
- ⑰ Clamp
- ⑱ Jet pump hose A
- ⑲ Fuel delivery hose A
- ⑳ Fuel return hose A
- ㉑ Fuel pipe ASSY
- ㉒ Jet pump hose B

- ㉓ Fuel delivery hose B
- ㉔ Fuel return hose B
- ㉕ Evaporation hose E
- ㉖ Fuel sub meter gasket
- ㉗ Jet pump filter
- ㉘ Fuel sub meter unit
- ㉙ Roll over valve

**Tightening torque: N·m (kg-m, ft-lb)**  
**T1: 4.4±1.5 (0.45±0.15, 3.3±1.1)**  
**T2: 7.4±2.0 (0.75±0.2, 5.4±1.4)**  
**T3: 33±10 (3.4±1.0, 25±7)**

2. FWD MODEL

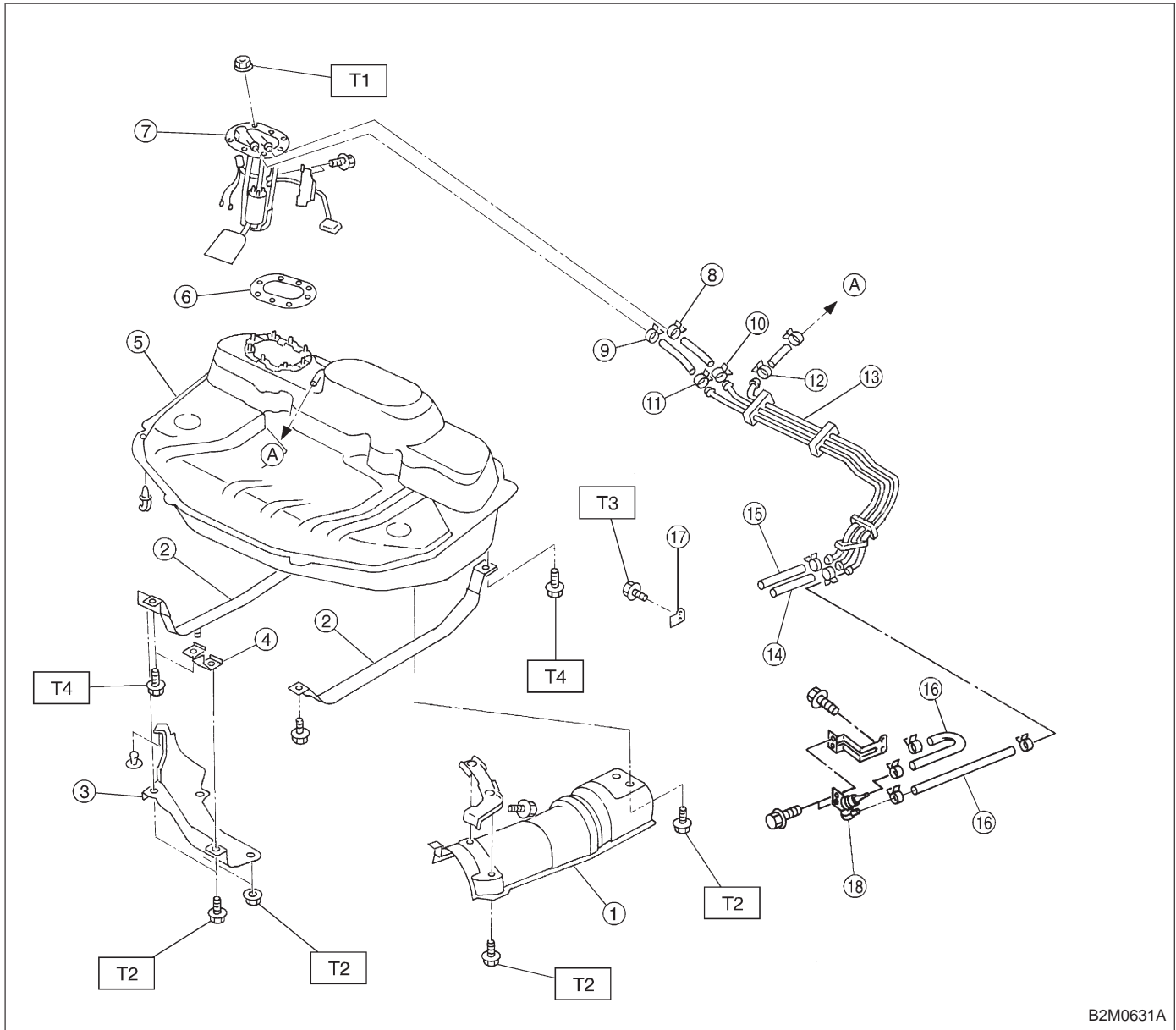

B2M0631A

- ① Heat seated cover
- ② Fuel tank band
- ③ Protector
- ④ Protector bracket
- ⑤ Fuel tank
- ⑥ Fuel pump gasket
- ⑦ Fuel pump ASSY
- ⑧ Clamp
- ⑨ Clip
- ⑩ Fuel delivery hose A
- ⑪ Fuel return hose A
- ⑫ Evaporation hose A
- ⑬ Fuel pipe ASSY

- ⑭ Fuel delivery hose B
- ⑮ Fuel return hose B
- ⑯ Evaporation hose B
- ⑰ Plate
- ⑱ Roll over valve

**Tightening torque: N·m (kg·m, ft·lb)**

**T1: 4.4±1.5 (0.45±0.15, 3.3±1.1)**

**T2: 7.4±0.2 (0.75±0.2, 5.4±1.4)**

**T3: 18±5 (1.8±0.5, 13.0±3.6)**

**T4: 33±10 (3.4±1.0, 25±7)**



2. Fuel Line

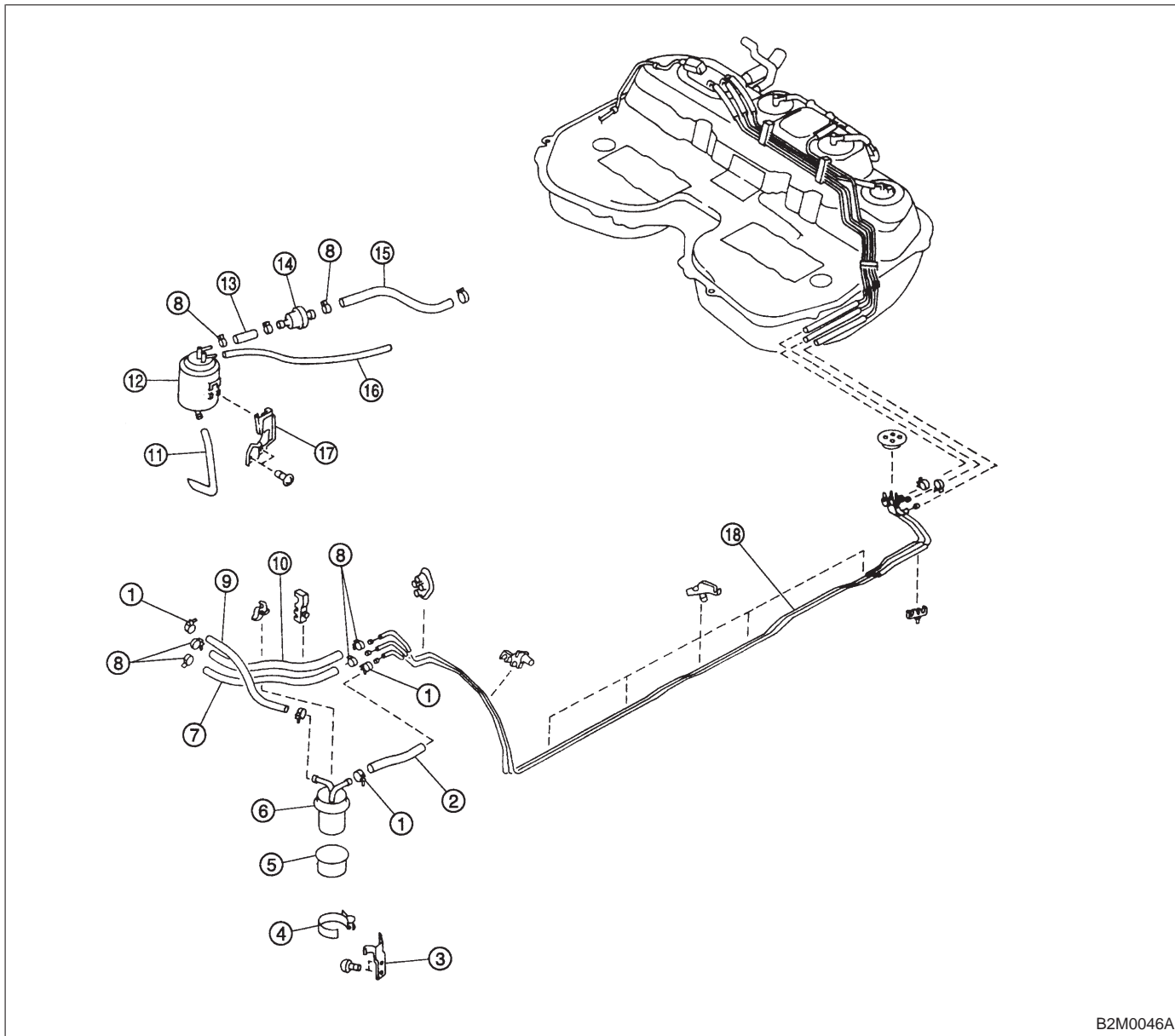

B2M0046A

- ① Clamp
- ② Fuel delivery hose A
- ③ Fuel filter bracket
- ④ Fuel filter holder
- ⑤ Fuel filter cup
- ⑥ Fuel filter
- ⑦ Evaporation hose
- ⑧ Clip
- ⑨ Fuel delivery hose B

- ⑩ Fuel return hose
- ⑪ Air vent hose
- ⑫ Canister
- ⑬ Canister hose A
- ⑭ Two-way valve
- ⑮ Canister hose B
- ⑯ Canister hose C
- ⑰ Canister bracket
- ⑱ Fuel pipe ASSY

## 1. Precautions

### WARNING:

- Place “No fire” signs near the working area.
- Disconnect ground terminal from battery.
- Be careful not to spill fuel on the floor.

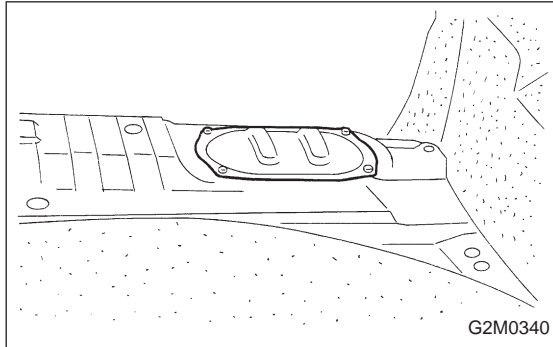

### A: RELEASING OF FUEL PRESSURE

- 1) Take off floor mat.
- 2) Remove access hole lid.

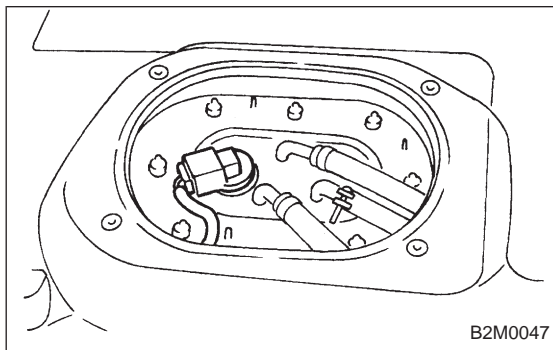

- 3) Disconnect connector from fuel pump.
- 4) Start the engine, and run it until it stalls.
- 5) After the engine stalls, crank it for five more seconds.
- 6) Turn ignition switch OFF.

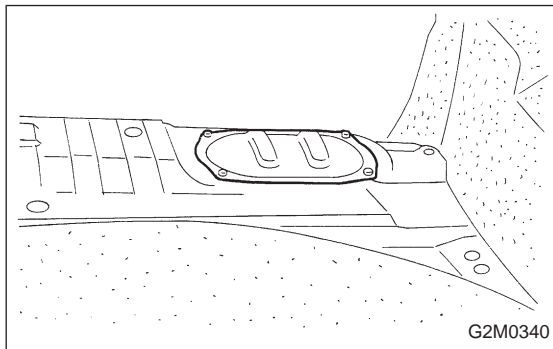

### B: DRAINING OF FUEL

- 1) Remove rear seat and seat back.
- 2) Remove access hole lid.

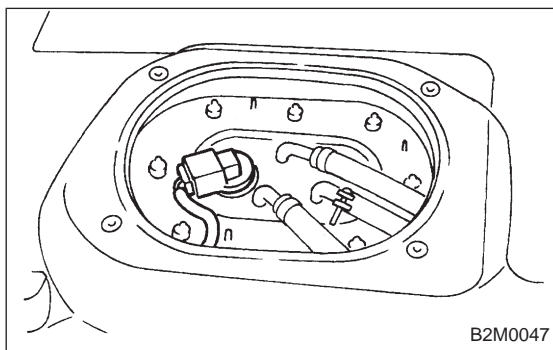

- 3) Disconnect connector from fuel pump.
- 4) Release fuel pressure. <Ref. to 2-8 [W1A0].>

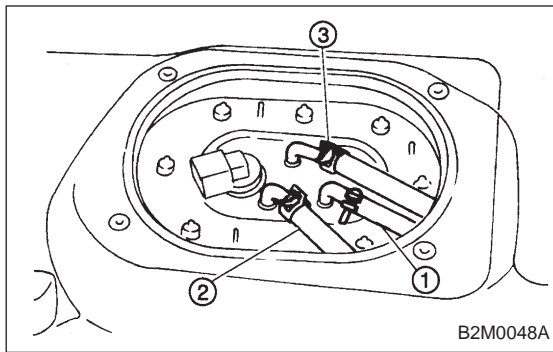

- 5) Disconnect fuel delivery hose ① and return hose ②.
- 6) Disconnect jet pump hose ③. (AWD model)

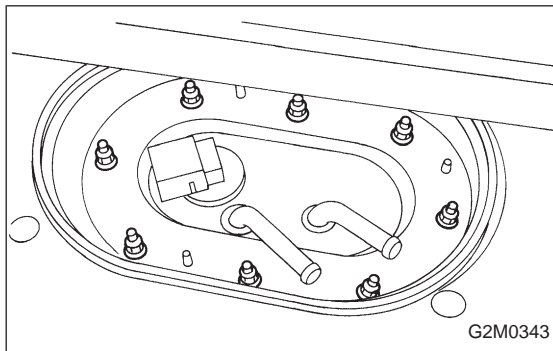

- 7) Remove nuts which install fuel pump assembly onto fuel tank.

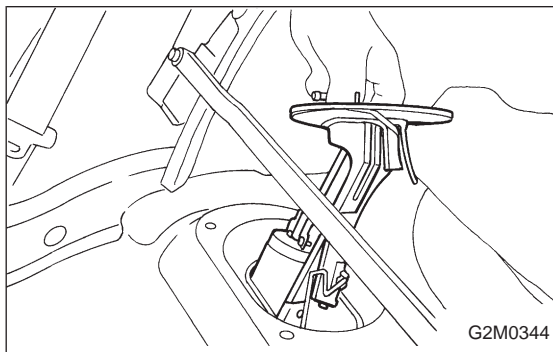

- 8) Take off fuel pump from fuel tank.

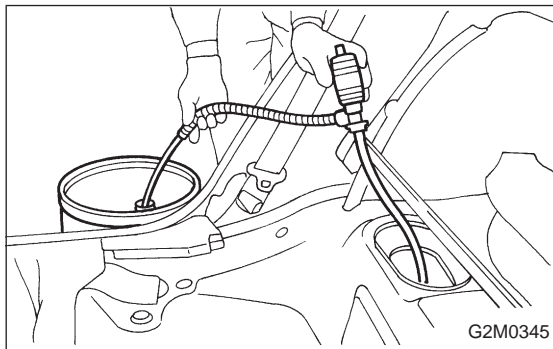

- 9) Drain fuel from fuel tank by using a hand pump.
- WARNING:**  
Do not use a motor pump when draining fuel.

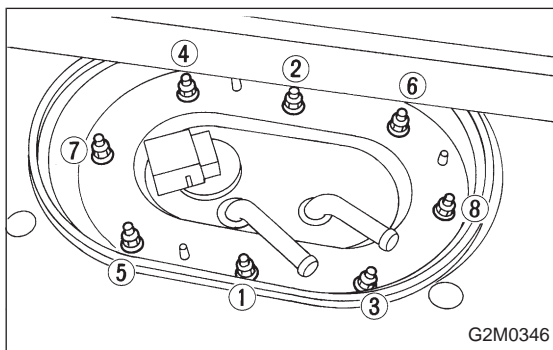

- 10) After draining fuel, reinstall fuel pump. Tighten nuts in numerical sequence shown in Figure to specified torque.

**Tightening torque:**  
 $4.4 \pm 1.5 \text{ N}\cdot\text{m}$  ( $0.45 \pm 0.15 \text{ kg}\cdot\text{m}$ ,  $3.3 \pm 1.1 \text{ ft}\cdot\text{lb}$ )

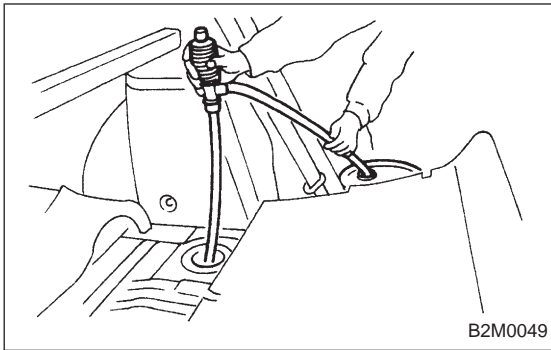

11) On AWD model, after removing fuel sub meter unit, drain fuel from there.

**WARNING:**

**Do not use a motor pump when draining fuel.**

## 2. On-Car Services

### A: MEASUREMENT OF FUEL PRESSURE

- 1) Release fuel pressure. <Ref. to 2-8 [W1A0].>
- 2) Connect connector to fuel pump.

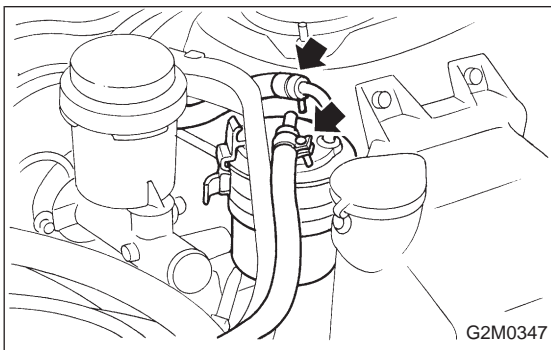

3) Disconnect fuel delivery hoses from fuel filter, and connect fuel pressure gauge.

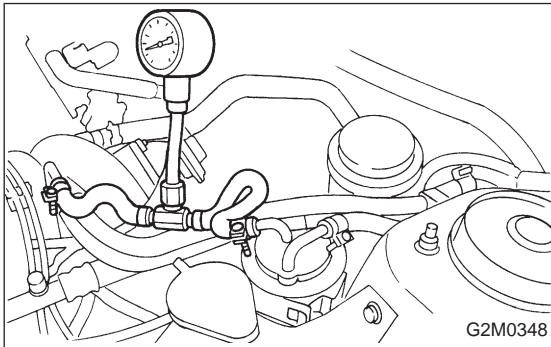

- 4) Start the engine.
- 5) Measure fuel pressure while disconnecting pressure regulator vacuum hose from collector chamber.

**Fuel pressure:**

**235 — 265 kPa (2.4 — 2.7 kg/cm<sup>2</sup>, 34 — 38 psi)**

6) After connecting pressure regulator vacuum hose, measure fuel pressure.

**Fuel pressure:**

**177 — 206 kPa (1.8 — 2.1 kg/cm<sup>2</sup>, 26 — 30 psi)**

**WARNING:**

**Before removing fuel pressure gauge, release fuel pressure.**

**NOTE:**

If out of specification as measured at step 6), check or replace pressure regulator and pressure regulator vacuum hose.

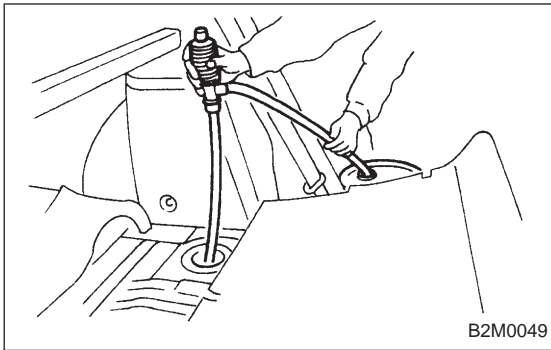

11) On AWD model, after removing fuel sub meter unit, drain fuel from there.

**WARNING:**

**Do not use a motor pump when draining fuel.**

## 2. On-Car Services

### A: MEASUREMENT OF FUEL PRESSURE

- 1) Release fuel pressure. <Ref. to 2-8 [W1A0].>
- 2) Connect connector to fuel pump.

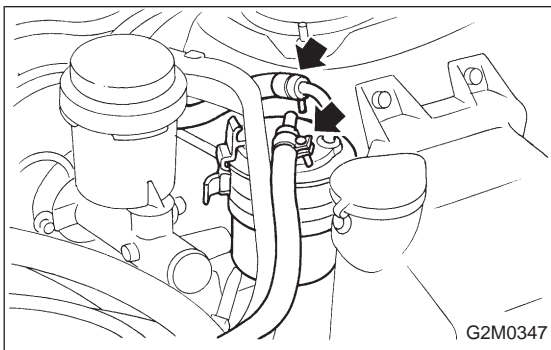

3) Disconnect fuel delivery hoses from fuel filter, and connect fuel pressure gauge.

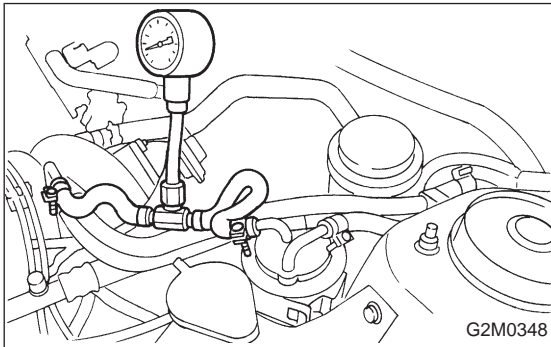

- 4) Start the engine.
- 5) Measure fuel pressure while disconnecting pressure regulator vacuum hose from collector chamber.

**Fuel pressure:**

**235 — 265 kPa (2.4 — 2.7 kg/cm<sup>2</sup>, 34 — 38 psi)**

6) After connecting pressure regulator vacuum hose, measure fuel pressure.

**Fuel pressure:**

**177 — 206 kPa (1.8 — 2.1 kg/cm<sup>2</sup>, 26 — 30 psi)**

**WARNING:**

**Before removing fuel pressure gauge, release fuel pressure.**

**NOTE:**

If out of specification as measured at step 6), check or replace pressure regulator and pressure regulator vacuum hose.

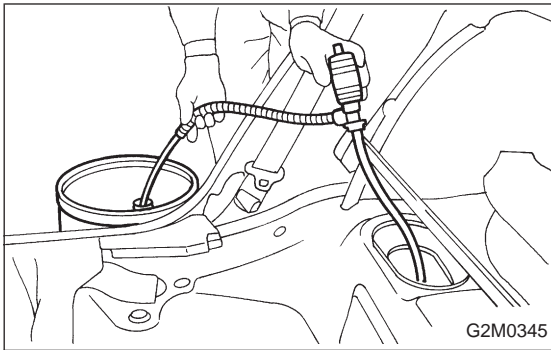

### 3. Fuel Tank

#### A: REMOVAL

- 1) Release fuel pressure. <Ref. to 2-8 [W1A0].>
- 2) Drain fuel from fuel tank. <Ref. to 2-8 [W1B0].>

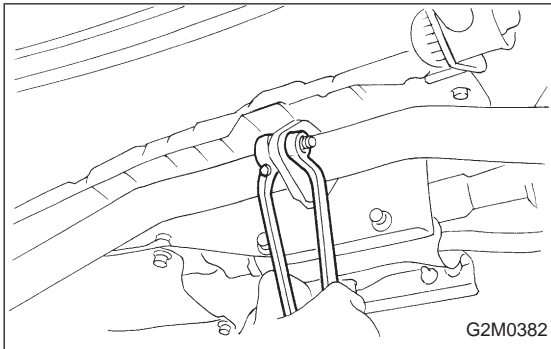

- 3) Remove rear exhaust pipe.
  - (1) Lift-up the vehicle.
  - (2) Separate rear exhaust pipe from center exhaust pipe.
  - (3) Separate rear exhaust pipe from muffler.
  - (4) Remove bracket from rubber cushion, and remove exhaust pipe.

#### NOTE:

To facilitate the removal of parts, apply a coat of SUBARU CRC5-56 (Part No. 004301003)

<Ref. to 2-9 [W2A0].>

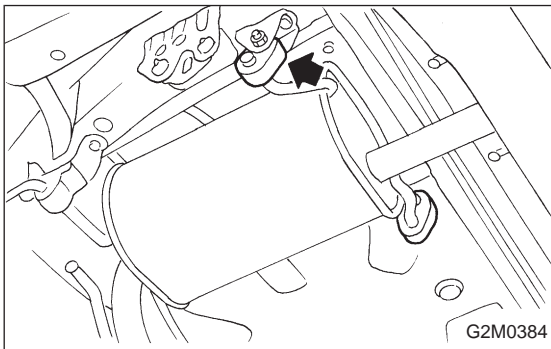

- 4) Remove muffler assembly.

#### NOTE:

To facilitate the removal of parts, apply a coat of SUBARU CRC5-56 (Part No. 004301003)

<Ref. to 2-9 [W3A0].>

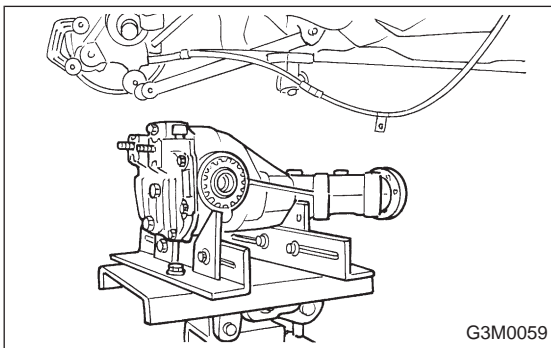

- 5) Remove rear differential assembly. (AWD model)

- (1) Remove rear axle shafts from rear differential assembly.
- (2) Remove rear differential front cover.
- (3) Remove propeller shaft.
- (4) Remove lower differential bracket.
- (5) Set transmission jack under rear differential.
- (6) Remove bolts which install rear differential onto rear crossmember.

<Ref. to 3-4 [W2B0].>

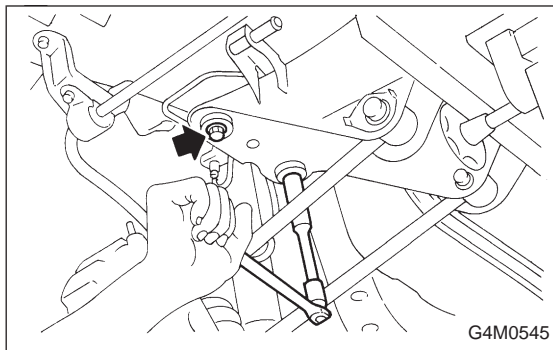

- 6) Remove rear crossmember. (AWD model)  
<Ref. to 4-1 [W11A0].>

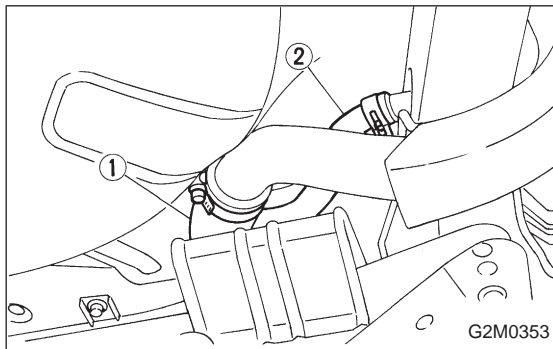

- 7) Loosen clamp, and disconnect fuel filler hose from pipe.  
8) Loosen clamp, and disconnect air vent hose from air vent pipe.

- ① Fuel filler hose  
② Air vent hose

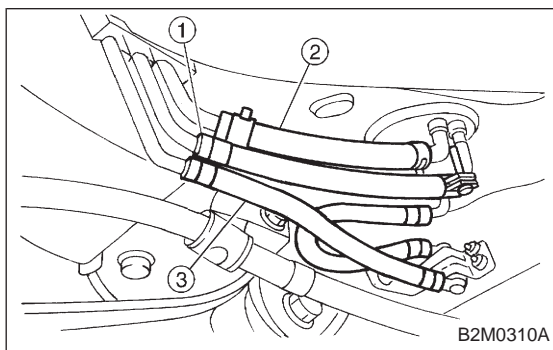

- 9) Loosen clip and clamps, and disconnect fuel delivery hose ①, return hose ② and evaporation hose ③.

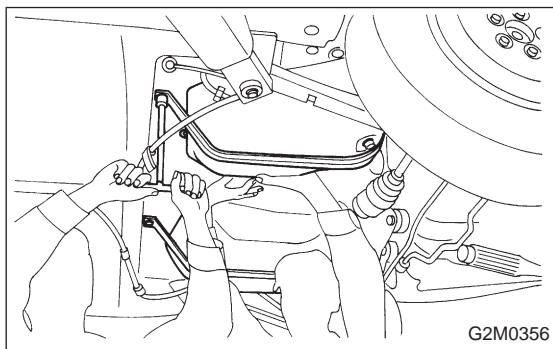

- 10) While holding fuel tank, remove bolts from bands and dismount fuel tank.

**WARNING:**

**A helper is required to perform step 10).**

**B: INSTALLATION**

Installation is in the reverse order of removal. Do the following:

- 1) When installing fuel tank, have a helper hold fuel tank while installing bands.
- 2) Before tightening band mounting bolts, connect fuel system hoses.

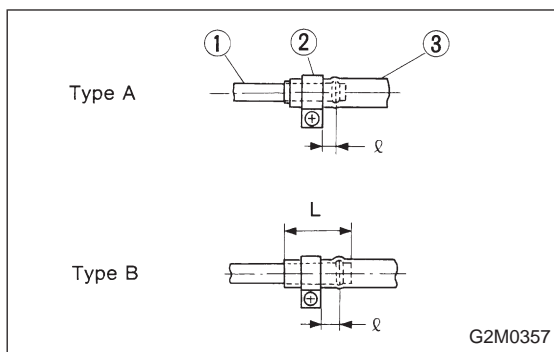

3) Install hose and hold down clips at positions indicated in Figure.

**Tightening torque:**

$1.0^{+0.5}_{-0} \text{ N}\cdot\text{m} (0.1^{+0.05}_{-0} \text{ kg}\cdot\text{m}, 0.7^{+0.4}_{-0} \text{ ft}\cdot\text{lb})$

Type A: When fitting length is specified.

Type B: When fitting length is not specified.

- ① Fitting
- ② Clamp
- ③ Hose

$\ell : 1.0 - 4.0 \text{ mm} (0.039 - 0.157 \text{ in})$

$L : 20 - 25 \text{ mm} (0.79 - 0.98 \text{ in})$

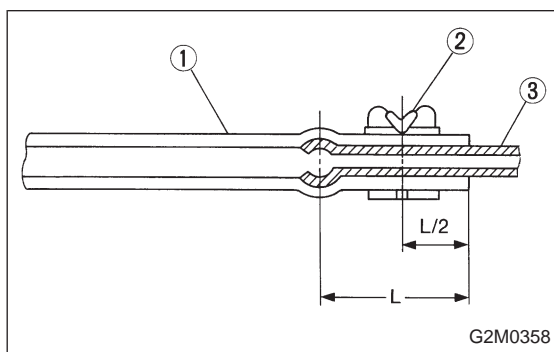

- ① Hose
- ② Clip
- ③ Pipe

**Fuel return hose:**

$L = 20 - 25 \text{ mm} (0.79 - 0.98 \text{ in})$

**Evaporation hose:**

$L = 15 - 20 \text{ mm} (0.59 - 0.79 \text{ in})$

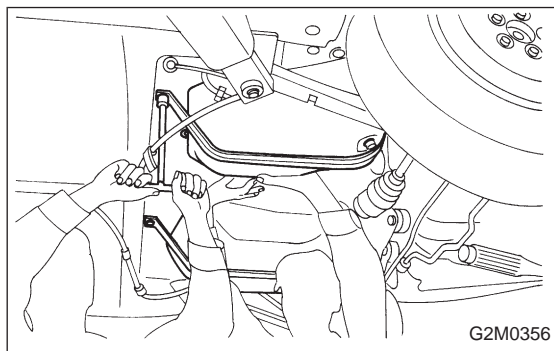

4) Tighten band mounting bolts.

**Tightening torque:**

$33 \pm 10 \text{ N}\cdot\text{m} (3.4 \pm 1.0 \text{ kg}\cdot\text{m}, 25 \pm 7 \text{ ft}\cdot\text{lb})$

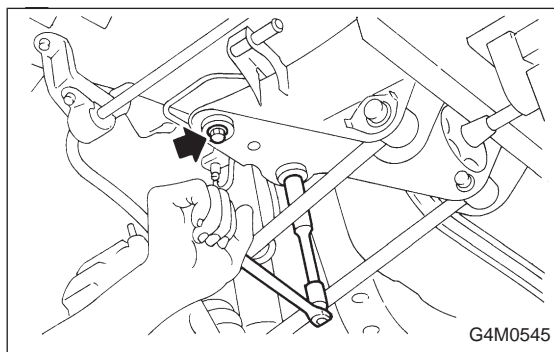

5) Install rear crossmember. <Ref. to 4-1 [W11C0].>



## 3. Fuel Tank - 4. Fuel Filler Pipe

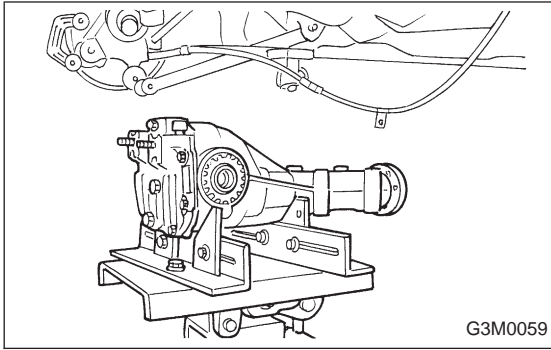

6) Install rear differential assembly. <Ref. to 3-4 [W2F0].>

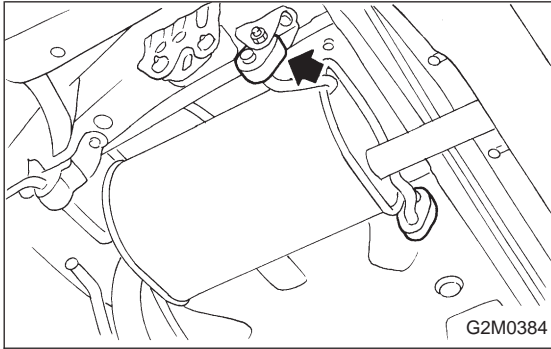

7) Install muffler assembly.

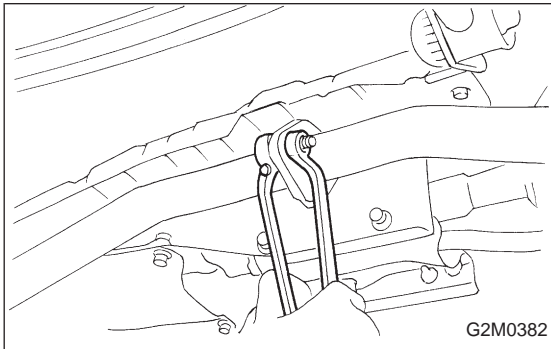

8) Install heat sealed cover.  
9) Install rear exhaust pipe.

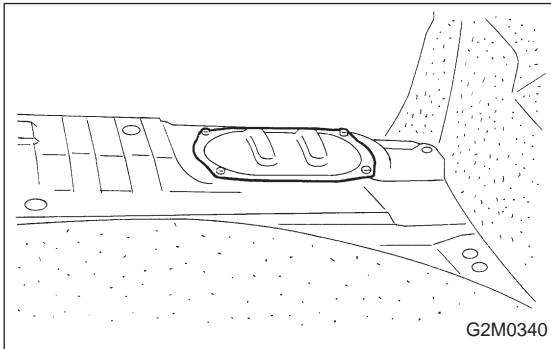

10) Lower the vehicle, and connect connector to fuel pump.  
11) Install access hole lid.

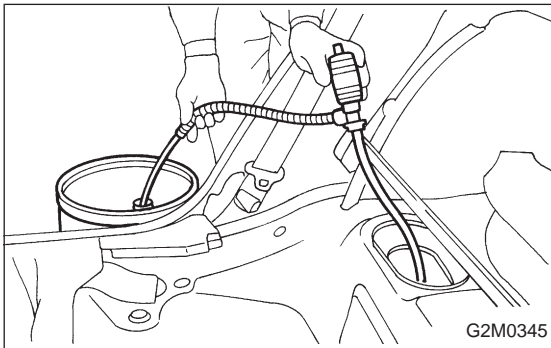

## 4. Fuel Filler Pipe

### A: REMOVAL

- 1) Release fuel pressure. <Ref. to 2-8 [W1A0].>
- 2) Drain fuel from fuel tank. <Ref. to 2-8 [W1B0].>

## 3. Fuel Tank - 4. Fuel Filler Pipe

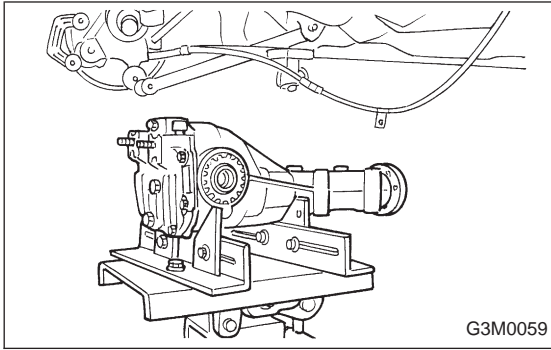

6) Install rear differential assembly. <Ref. to 3-4 [W2F0].>

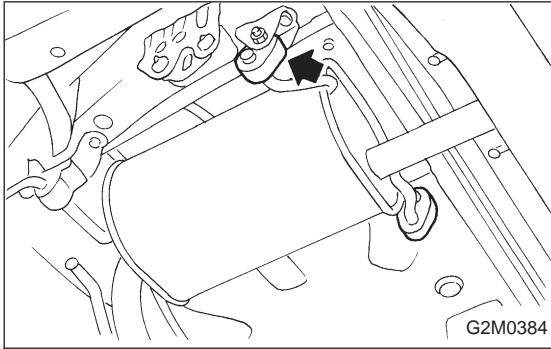

7) Install muffler assembly.

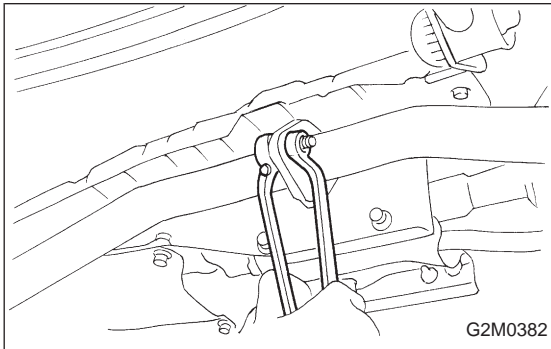

8) Install heat sealed cover.  
9) Install rear exhaust pipe.

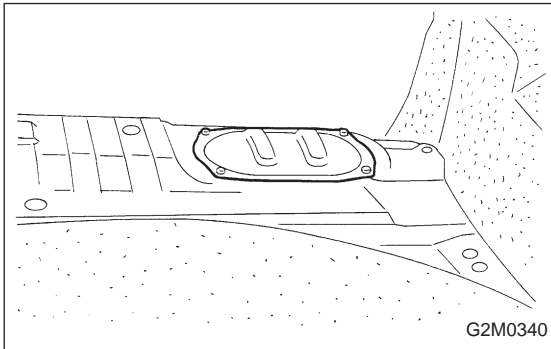

10) Lower the vehicle, and connect connector to fuel pump.  
11) Install access hole lid.

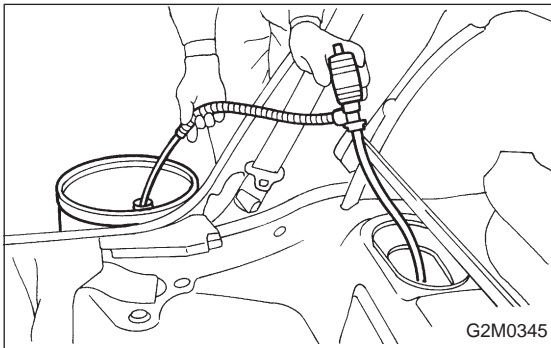

## 4. Fuel Filler Pipe

### A: REMOVAL

- 1) Release fuel pressure. <Ref. to 2-8 [W1A0].>
- 2) Drain fuel from fuel tank. <Ref. to 2-8 [W1B0].>

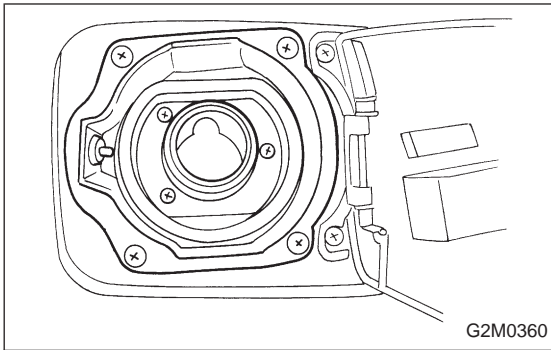

- 3) Remove right rear wheel.
- 4) Open fuel filler flap and remove filler cap.
- 5) Remove screws holding packing in place.

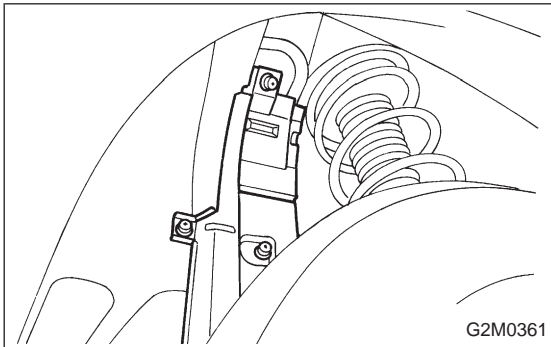

- 6) Lift-up the vehicle.
- 7) Remove fuel filler pipe protector.

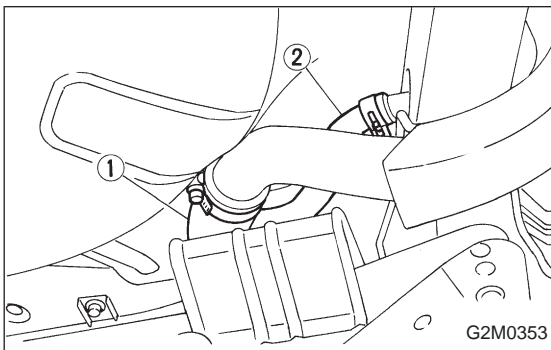

- 8) Remove clip, and separate air vent hose from pipe.
  - 9) Loosen clamp, and separate fuel filler hose from pipe.
- ① Fuel filler hose
  - ② Air vent hose
- 10) Remove fuel filler pipe to under side of the vehicle.

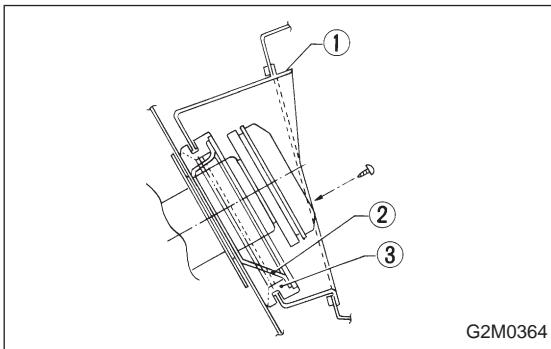

### B: INSTALLATION

- 1) Hold fuel filler flap open.
- 2) Set fuel saucer ① with rubber packing ③, and insert fuel filler pipe into hole from the inner side of apron.
- 3) Align holes in fuel filler pipe neck and set cup ②, and tighten screws.

#### NOTE:

If edges of rubber packing are folded toward the inside, straighten it with a screwdriver.

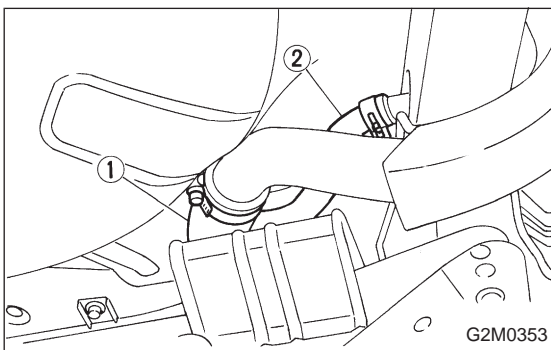

- 4) Insert fuel filler hose approximately 25 to 30 mm (0.98 to 1.18 in) over the lower end of fuel filler pipe and tighten clamp.

- ① Fuel filler hose
- ② Air vent hose

#### CAUTION:

**Do not allow clips to touch air vent hose and rear suspension crossmember.**

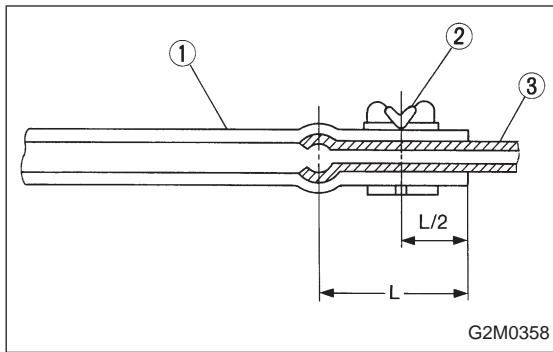

5) Insert air vent hose approximately 25 to 30 mm (0.98 to 1.18 in) into the lower end of air vent pipe and hold clip.

- ① Hose
- ② Clip
- ③ Pipe

$L = 25 - 30 \text{ mm (0.98 - 1.18 in)}$

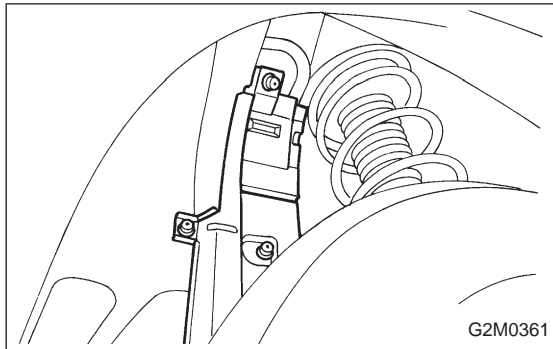

- 6) Install fuel filler pipe protector.
- 7) Install right rear wheel.

## 5. Fuel Filter

### A: REMOVAL

1) Release fuel pressure. <Ref. to 2-8 [W1A0].>

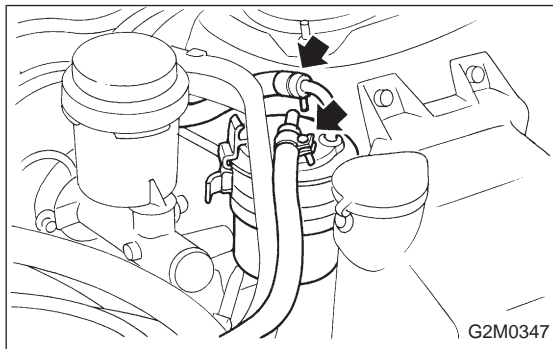

- 2) Disconnect fuel delivery hoses from fuel filter.
- 3) Remove filter from holder.

### B: INSPECTION

- 1) Check the inside of fuel filter for dirt and water sediment.
- 2) If it is clogged, or if replacement interval has been reached, replace it.
- 3) If water is found in it, shake and expel the water from inlet port.

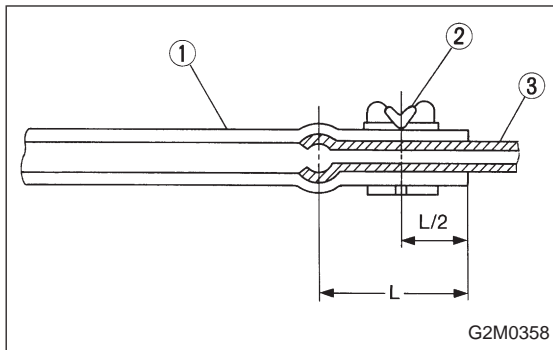

5) Insert air vent hose approximately 25 to 30 mm (0.98 to 1.18 in) into the lower end of air vent pipe and hold clip.

- ① Hose
- ② Clip
- ③ Pipe

$L = 25 - 30 \text{ mm (0.98 - 1.18 in)}$

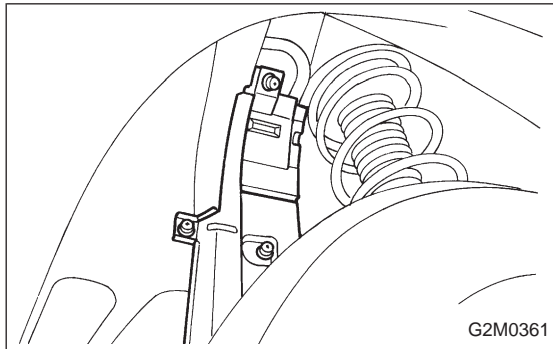

- 6) Install fuel filler pipe protector.
- 7) Install right rear wheel.

## 5. Fuel Filter

### A: REMOVAL

1) Release fuel pressure. <Ref. to 2-8 [W1A0].>

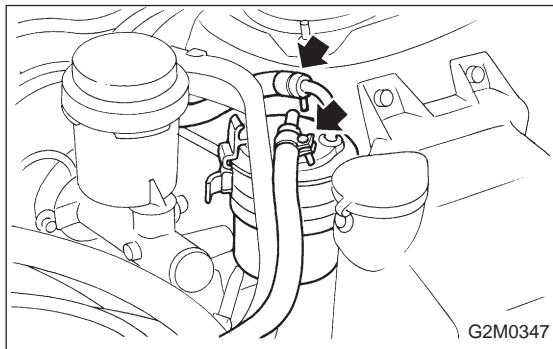

- 2) Disconnect fuel delivery hoses from fuel filter.
- 3) Remove filter from holder.

### B: INSPECTION

- 1) Check the inside of fuel filter for dirt and water sediment.
- 2) If it is clogged, or if replacement interval has been reached, replace it.
- 3) If water is found in it, shake and expel the water from inlet port.

**C: INSTALLATION****CAUTION:**

- If fuel hoses are damaged at the connecting portion, replace it with a new one.
- If clamps are badly damaged, replace with new ones.

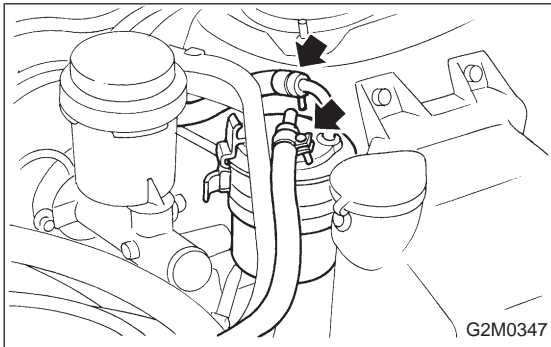

- 1) Installation is in the reverse order of removal.
- 2) Tighten hose clamp screws.

**Tightening torque:**

$1.0^{+0.5}_{-0}$  N·m ( $0.1^{+0.05}_{-0}$  kg·m,  $0.7^{+0.4}_{-0}$  ft-lb)

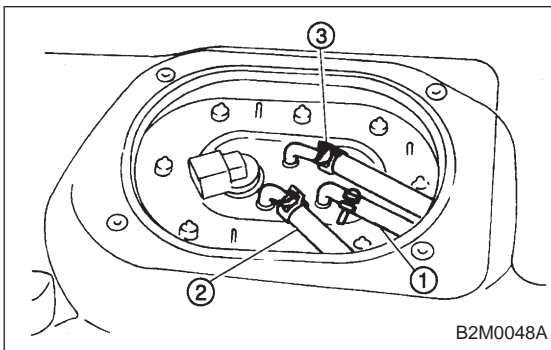
**6. Fuel Pump****A: REMOVAL**

- 1) Release fuel pressure. <Ref. to 2-8 [W1A0].>
- 2) Disconnect fuel delivery hose ① and return hose ②.
- 3) Disconnect jet pump hose ③. (AWD model)

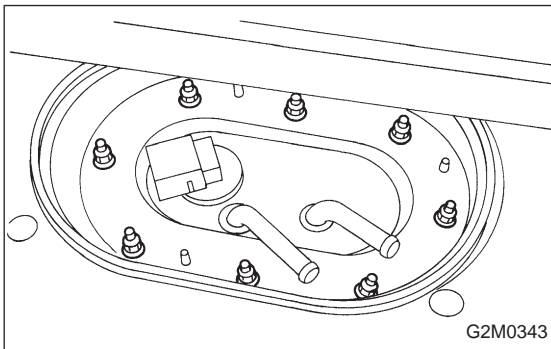

- 4) Remove nuts which install fuel pump assembly onto fuel tank.

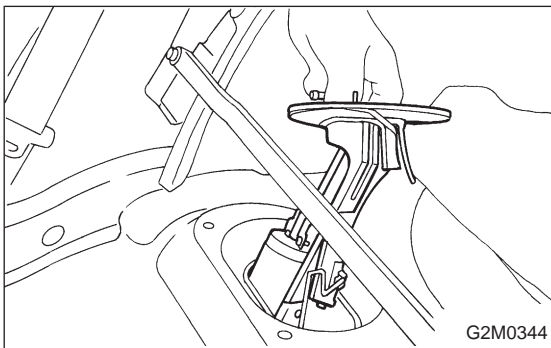

- 5) Take off fuel pump from fuel tank.

**C: INSTALLATION****CAUTION:**

- If fuel hoses are damaged at the connecting portion, replace it with a new one.
- If clamps are badly damaged, replace with new ones.

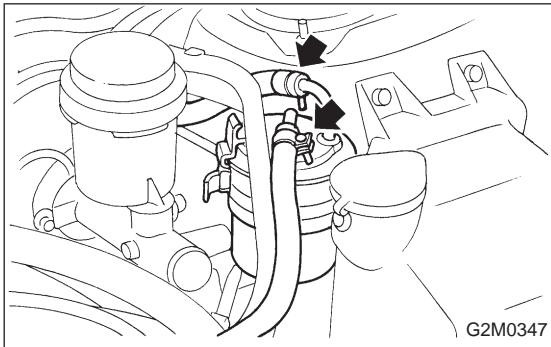

- 1) Installation is in the reverse order of removal.
- 2) Tighten hose clamp screws.

**Tightening torque:**

$1.0^{+0.5}_{-0}$  N·m ( $0.1^{+0.05}_{-0}$  kg·m,  $0.7^{+0.4}_{-0}$  ft-lb)

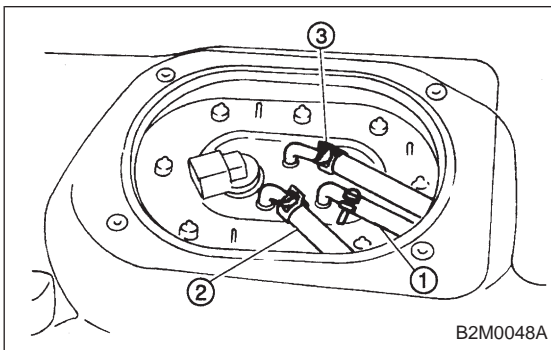
**6. Fuel Pump****A: REMOVAL**

- 1) Release fuel pressure. <Ref. to 2-8 [W1A0].>
- 2) Disconnect fuel delivery hose ① and return hose ②.
- 3) Disconnect jet pump hose ③. (AWD model)

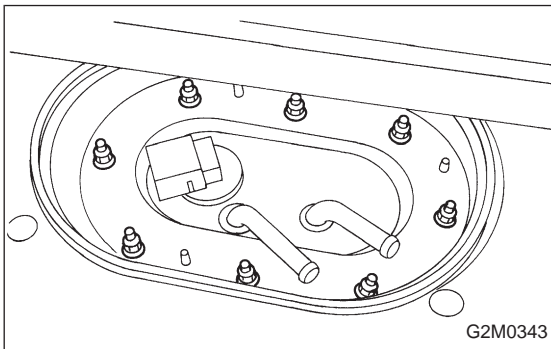

- 4) Remove nuts which install fuel pump assembly onto fuel tank.

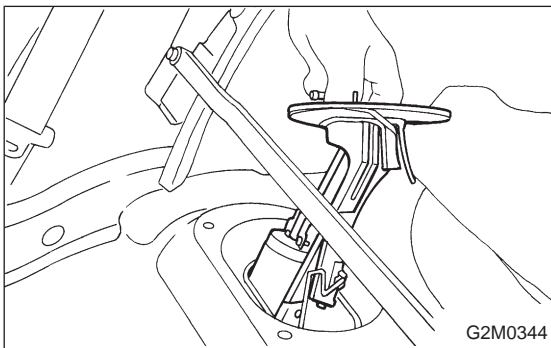

- 5) Take off fuel pump from fuel tank.

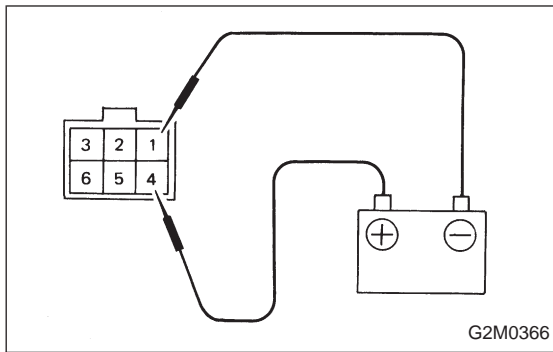

## B: INSPECTION

Connect lead harness to connector terminal of fuel pump, and apply battery power supply to check whether the pump operate.

### WARNING:

- Wipe off the fuel completely.
- Keep battery as far apart from fuel pump as possible.
- Be sure to turn the battery supply ON and OFF on the battery side.
- Do not run fuel pump for a long time under non-load condition.

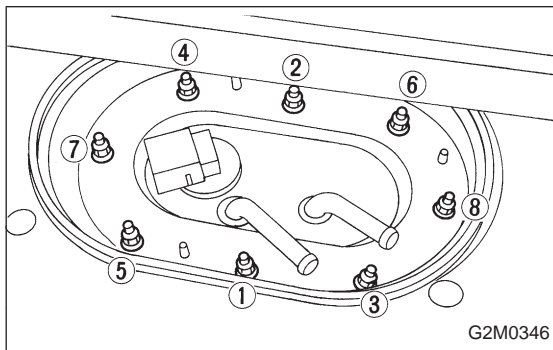

## C: INSTALLATION

Installation is in the reverse order of removal. Do the following:

- (1) Always use new gaskets.
- (2) Ensure sealing portion is free from fuel or foreign particles before installation.
- (3) Tighten nuts in numerical sequence shown in Figure to specified torque.

### Tightening torque:

$4.4 \pm 1.5 \text{ N}\cdot\text{m}$  ( $0.45 \pm 0.15 \text{ kg}\cdot\text{m}$ ,  $3.3 \pm 1.1 \text{ ft}\cdot\text{lb}$ )

## 7. Fuel Meter Unit

### A: REMOVAL

#### NOTE:

Fuel meter unit is built in fuel pump assembly.

- 1) Release fuel pressure. <Ref. to 2-8 [W1A0].>
- 2) Disconnect fuel delivery hose ① and return hose ②.
- 3) Disconnect jet pump hose ③. (AWD model)

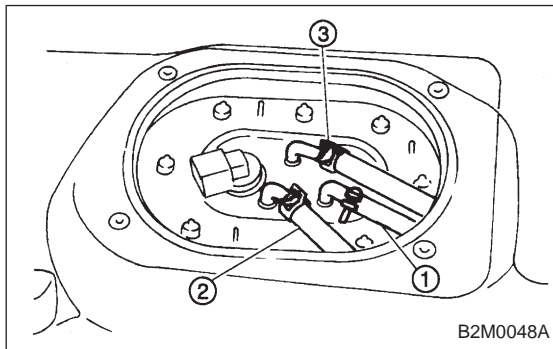



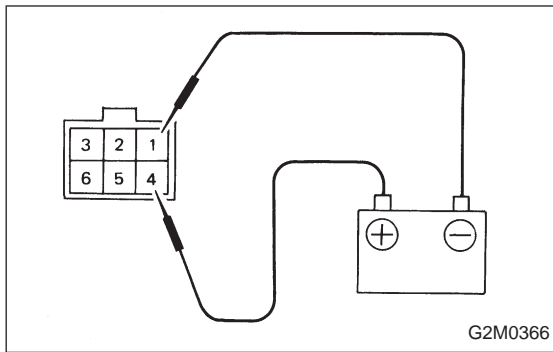

## B: INSPECTION

Connect lead harness to connector terminal of fuel pump, and apply battery power supply to check whether the pump operate.

### WARNING:

- Wipe off the fuel completely.
- Keep battery as far apart from fuel pump as possible.
- Be sure to turn the battery supply ON and OFF on the battery side.
- Do not run fuel pump for a long time under non-load condition.

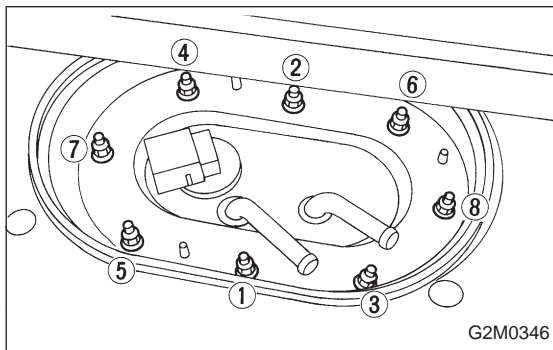

## C: INSTALLATION

Installation is in the reverse order of removal. Do the following:

- (1) Always use new gaskets.
- (2) Ensure sealing portion is free from fuel or foreign particles before installation.
- (3) Tighten nuts in numerical sequence shown in Figure to specified torque.

### Tightening torque:

$4.4 \pm 1.5 \text{ N}\cdot\text{m}$  ( $0.45 \pm 0.15 \text{ kg}\cdot\text{m}$ ,  $3.3 \pm 1.1 \text{ ft}\cdot\text{lb}$ )

## 7. Fuel Meter Unit

### A: REMOVAL

#### NOTE:

Fuel meter unit is built in fuel pump assembly.

- 1) Release fuel pressure. <Ref. to 2-8 [W1A0].>
- 2) Disconnect fuel delivery hose ① and return hose ②.
- 3) Disconnect jet pump hose ③. (AWD model)

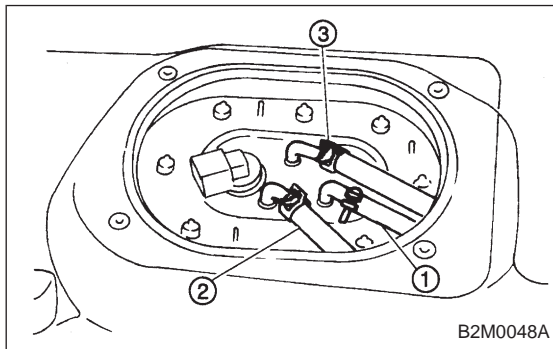

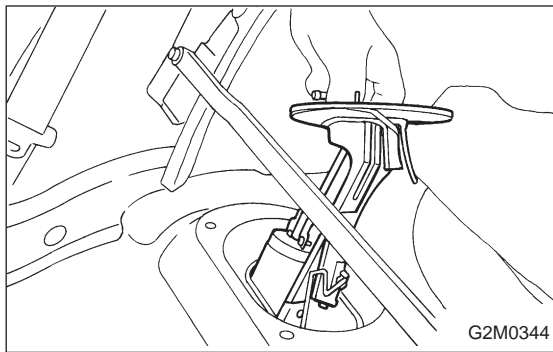

- 4) Remove nuts which install fuel pump assembly onto fuel tank.
- 5) Take off fuel pump assembly.

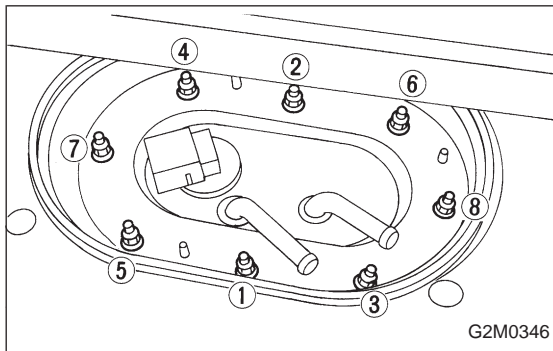

**B: INSTALLATION**

Installation is in the reverse order of removal. Do the following:

- (1) Always use new gaskets.
- (2) Ensure sealing portion is free from fuel or foreign particles before installation.
- (3) Tighten nuts in numerical sequence shown in Figure to specified torque.

**Tightening torque:**

***4.4±1.5 N·m (0.45±0.15 kg·m, 3.3±1.1 ft-lb)***

## 8. Fuel Delivery, Return and Evaporation Lines

### A: REMOVAL

- 1) Release fuel pressure. <Ref. to 2-8 [W1A0].>
- 2) Remove inner trim, insulator and rear seat.
- 3) Remove fuel delivery pipes and hoses, fuel return pipes and hoses, and evaporation pipes and hoses.

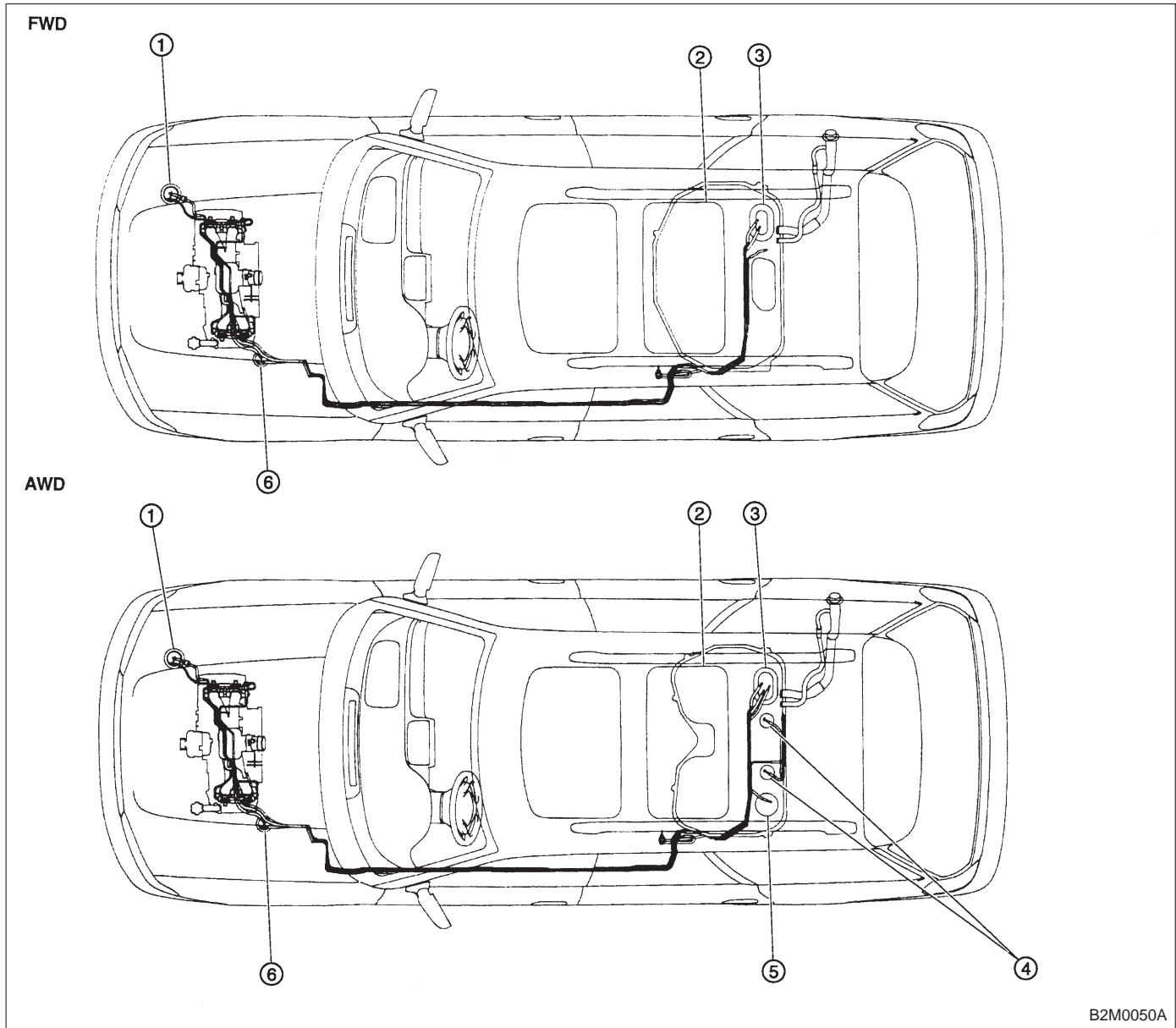

B2M0050A

- ① Canister
- ② Fuel tank
- ③ Fuel pump

- ④ Fuel cut valve (AWD)
- ⑤ Fuel sub meter unit (AWD)
- ⑥ Fuel filter

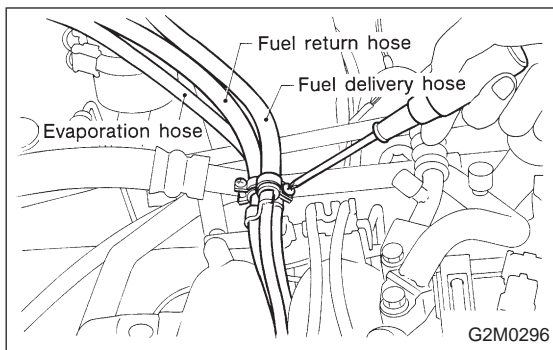

4) In engine compartment, detach fuel delivery hose, return hose and evaporation hose.

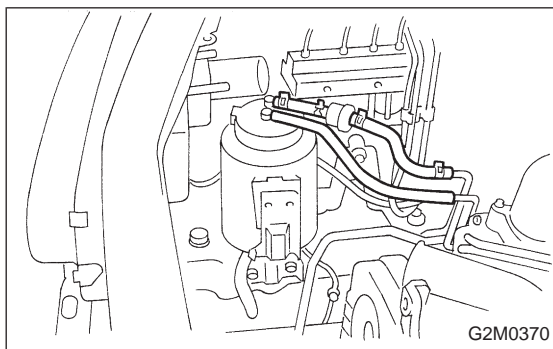

5) In engine compartment, detach canister hoses from canister.

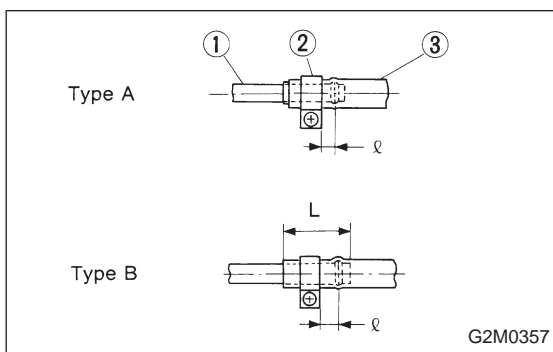

**B: INSTALLATION**

Installation is in the reverse order of removal.

1) Connect fuel delivery hose to pipe with an overlap of 20 to 25 mm (0.79 to 0.98 in).

Type A: When fitting length is specified.

Type B: When fitting length is not specified.

- ① Fitting
- ② Clamp
- ③ Hose

$\ell$  : 1.0 — 4.0 mm (0.039 — 0.157 in)

$L$  : 20 — 25 mm (0.79 — 0.98 in)

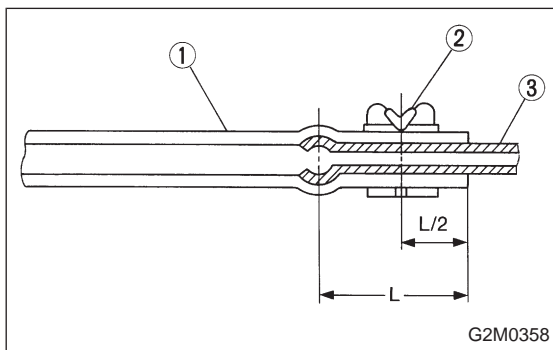

2) Connect evaporation hose to pipe by approx. 15 mm (0.59 in) from hose end.

- ① Hose
- ② Clip
- ③ Pipe

$L = 15 — 20 \text{ mm (0.59 — 0.79 in)}$

**CAUTION:**

Be sure to inspect hoses and their connections for any leakage of fuel.

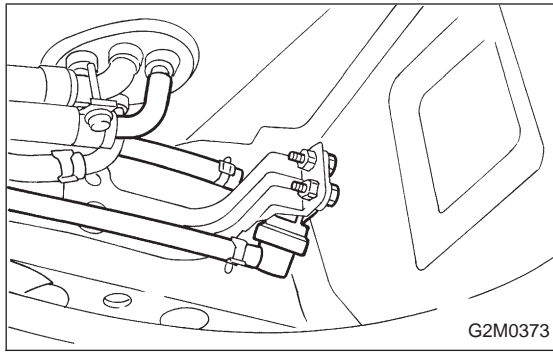

## 9. Roll Over Valve

### A: REMOVAL

- 1) Lift up the vehicle.
- 2) Remove roll over valve with bracket.
- 3) Disconnect hoses from roll over valve, and remove it from bracket.

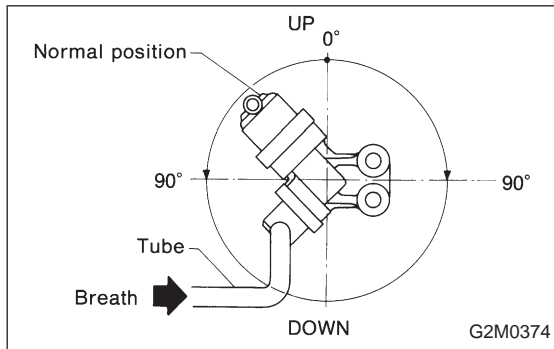

### B: INSPECTION

- 1) Connect hoses to roll over valve as shown in Figure.
- 2) While blowing through open end of hose, tilt valve at least 90° left and right from normal position.
- 3) Ensure that there is no air flow when hose is tilted greater than 90°.

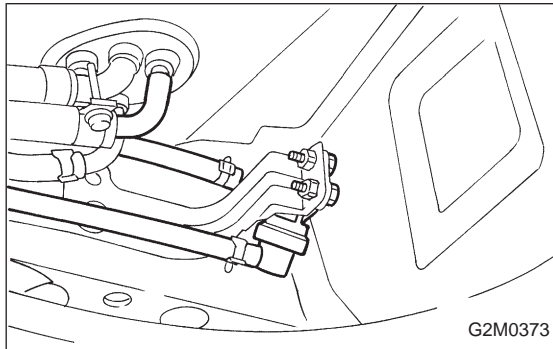

### C: INSTALLATION

Installation is in the reverse order of removal.

#### CAUTION:

- Do not install top side of valve down.
- Before installing bracket on body, securely fit concave part of bracket to hole in body.

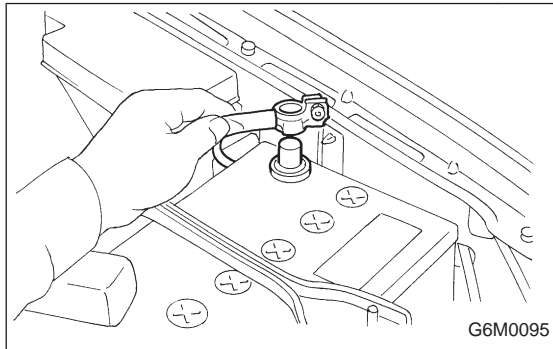

## 10. Fuel Sub Meter Unit (AWD model only)

### A: REMOVAL AND INSTALLATION

- 1) Disconnect battery ground cable.

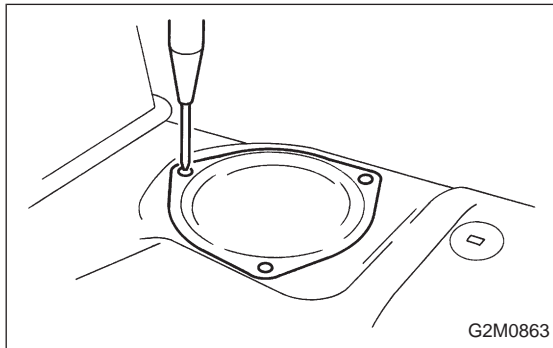

- 2) Remove rear seat.
- 3) Remove service hole cover.

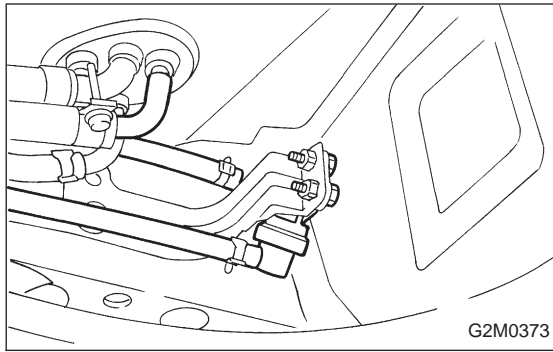

## 9. Roll Over Valve

### A: REMOVAL

- 1) Lift up the vehicle.
- 2) Remove roll over valve with bracket.
- 3) Disconnect hoses from roll over valve, and remove it from bracket.

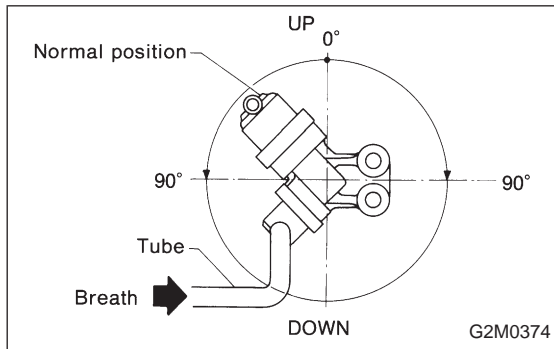

### B: INSPECTION

- 1) Connect hoses to roll over valve as shown in Figure.
- 2) While blowing through open end of hose, tilt valve at least 90° left and right from normal position.
- 3) Ensure that there is no air flow when hose is tilted greater than 90°.

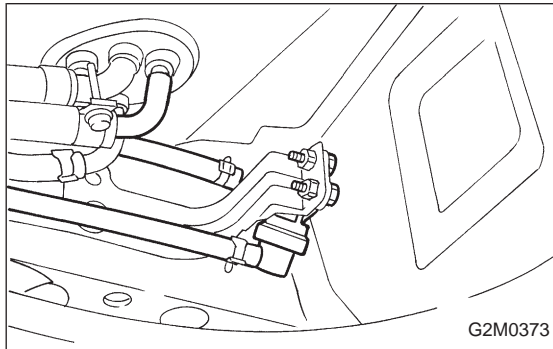

### C: INSTALLATION

Installation is in the reverse order of removal.

#### CAUTION:

- Do not install top side of valve down.
- Before installing bracket on body, securely fit concave part of bracket to hole in body.

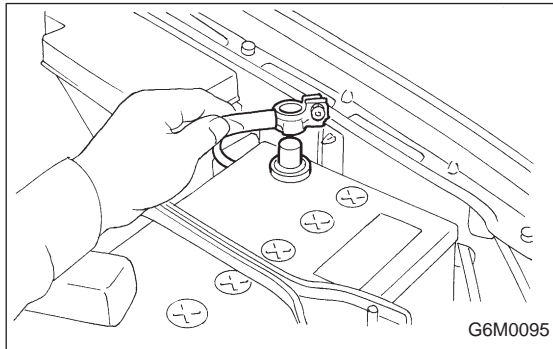

## 10. Fuel Sub Meter Unit (AWD model only)

### A: REMOVAL AND INSTALLATION

- 1) Disconnect battery ground cable.

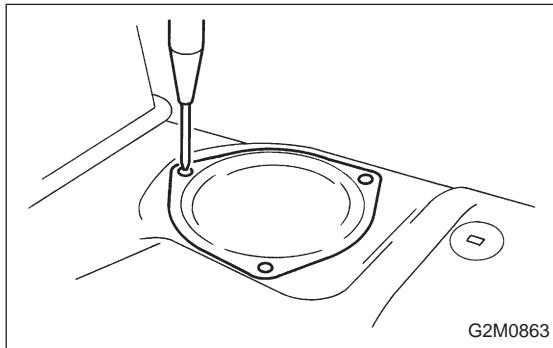

- 2) Remove rear seat.
- 3) Remove service hole cover.

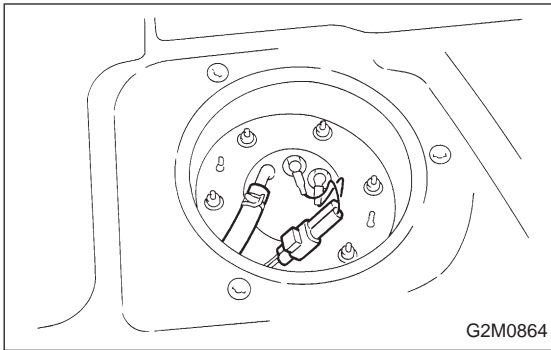

- 4) Disconnect connector from fuel sub meter.
- 5) Disconnect jet pump hose.

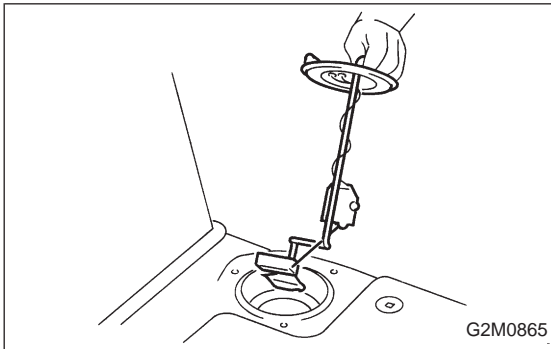

- 6) Remove fuel sub meter unit.

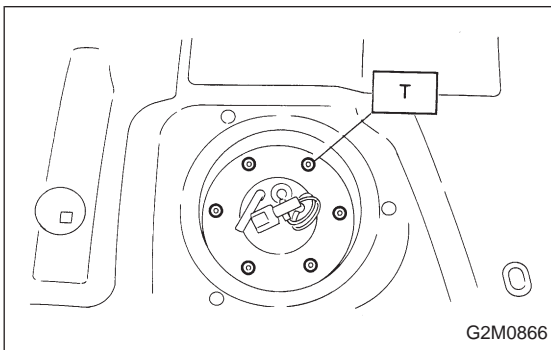

- 7) Installation is in the reverse order of removal procedure.

**Tightening torque:**

***T: 3 — 6 N·m (0.3 — 0.6 kg·m, 2.2 — 4.3 ft·lb)***

**11. Fuel Cut Valve (AWD model only)**

**A: REMOVAL AND INSTALLATION**

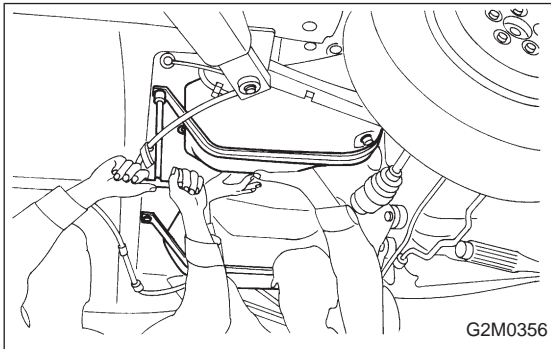

- 1) Remove fuel tank. <Ref. to 2-8 [W3A0].>

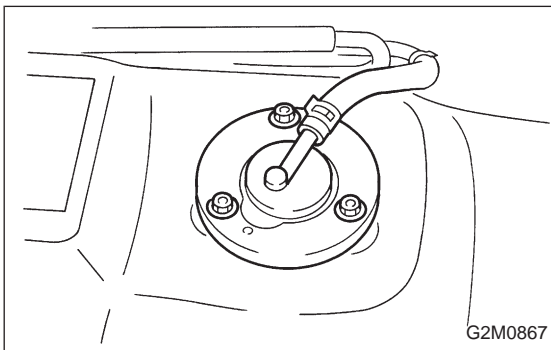

- 2) Disconnect evaporation hose from fuel cut valve.
- 3) Remove fuel cut valve.
- 4) Installation is in the reverse order of removal procedure.

**Tightening torque:**

***4.4±1.5 N·m (0.45±0.15 kg·m, 3.3±1.1 ft·lb)***

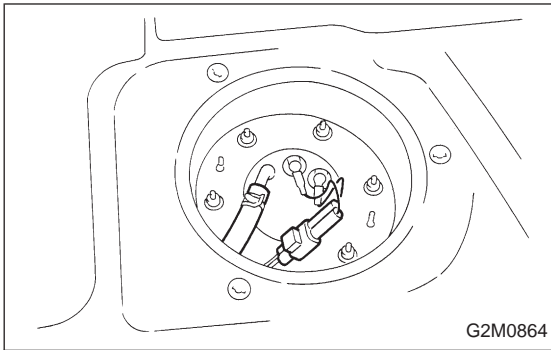

- 4) Disconnect connector from fuel sub meter.
- 5) Disconnect jet pump hose.

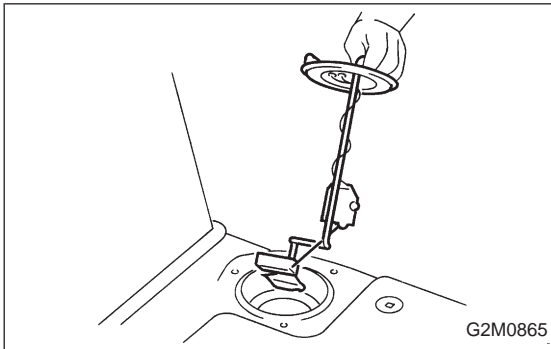

- 6) Remove fuel sub meter unit.

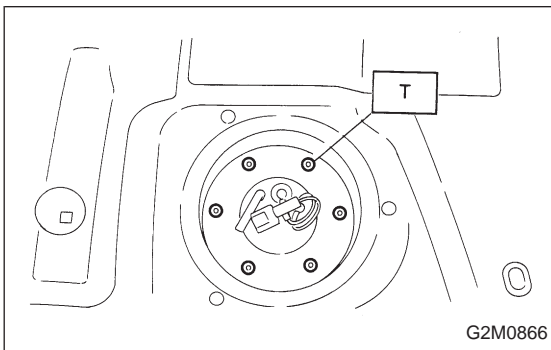

- 7) Installation is in the reverse order of removal procedure.

**Tightening torque:**

***T: 3 — 6 N·m (0.3 — 0.6 kg·m, 2.2 — 4.3 ft·lb)***

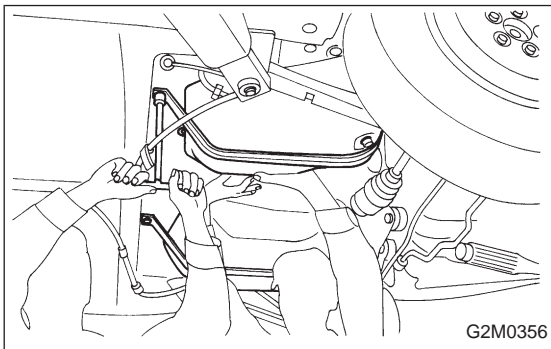

**11. Fuel Cut Valve (AWD model only)**

**A: REMOVAL AND INSTALLATION**

- 1) Remove fuel tank. <Ref. to 2-8 [W3A0].>

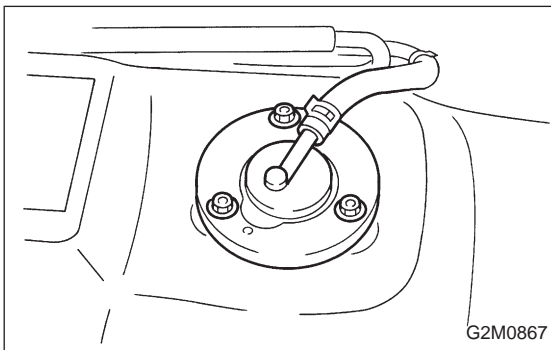

- 2) Disconnect evaporation hose from fuel cut valve.
- 3) Remove fuel cut valve.
- 4) Installation is in the reverse order of removal procedure.

**Tightening torque:**

***4.4±1.5 N·m (0.45±0.15 kg·m, 3.3±1.1 ft·lb)***



## 1. Fuel System

Trouble and possible cause		Corrective action
<b>1. Insufficient fuel supply to the injector</b>		
1)	Fuel pump will not operate.	
	○ Defective terminal contact.	Inspect connections, especially ground, and tighten securely.
	○ Trouble in electromagnetic or electronic circuit parts.	Replace fuel pump.
2)	Lowering of fuel pump function.	Replace fuel pump.
3)	Clogged dust or water in the fuel filter.	Replace fuel filter, clean or replace fuel tank.
4)	Clogged or bent fuel pipe or hose.	Clean, correct or replace fuel pipe or hose.
5)	Air is mixed in the fuel system.	Inspect or retighten each connection part.
6)	Clogged or bent breather tube or pipe.	Clean, correct or replace air breather tube or pipe.
7)	Damaged diaphragm of pressure regulator.	Replace.
<b>2. Leakage or blow out fuel</b>		
1)	Loosened joints of the fuel pipe.	Retightening.
2)	Cracked fuel pipe, hose and fuel tank.	Replace.
3)	Defective welding part on the fuel tank.	Replace.
4)	Defective drain packing of the fuel tank.	Replace.
5)	Clogged or bent air breather tube or air vent tube.	Clean, correct or replace air breather tube or air vent tube.
<b>3. Gasoline smell inside of compartment</b>		
1)	Loose joints at air breather tube, air vent tube and fuel filler pipe.	Retightening.
2)	Defective packing air tightness on the fuel saucer.	Correct or replace packing.
3)	Cracked fuel separator.	Replace separator.
<b>4. Defective fuel meter indicator</b>		
1)	Defective operation of fuel meter unit.	Replace.
2)	Defective operation of fuel meter.	Replace.
<b>5. Noise</b>		
1)	Large operation noise or vibration of fuel pump.	Replace.

### NOTE:

When the vehicle is left unattended for an extended period of time, water may accumulate in the fuel tank.

- To prevent water condensation:
  - 1) Top off the fuel tank or drain the fuel completely.
  - 2) Drain water condensation from the fuel filter.

- Refilling the fuel tank:

Refill the fuel tank while there is still some fuel left in the tank.

- Protecting the fuel system against freezing and water condensation:

- 1) Cold areas

In snow-covered areas, mountainous areas, skiing areas, etc. where ambient temperatures drop below 0°C (32°F) throughout the winter season, use an anti-freeze solution in the cooling system.

Refueling will also complement the effect of anti-freeze solution each time the fuel level drops to about one-half. After the winter season, drain water which may have accumulated in the fuel filter and fuel tank in the manner same as that described under affected areas as below.

- 2) Affected areas

When water condensation is notched in the fuel filter, drain water from both the fuel filter and fuel tank or use a water removing agent (or anti-freeze solution) in the fuel tank.

- Observe the instructions, notes, etc., indicated on the label affixed to the anti-freeze solution (water removing agent) container before use.

1. Exhaust System

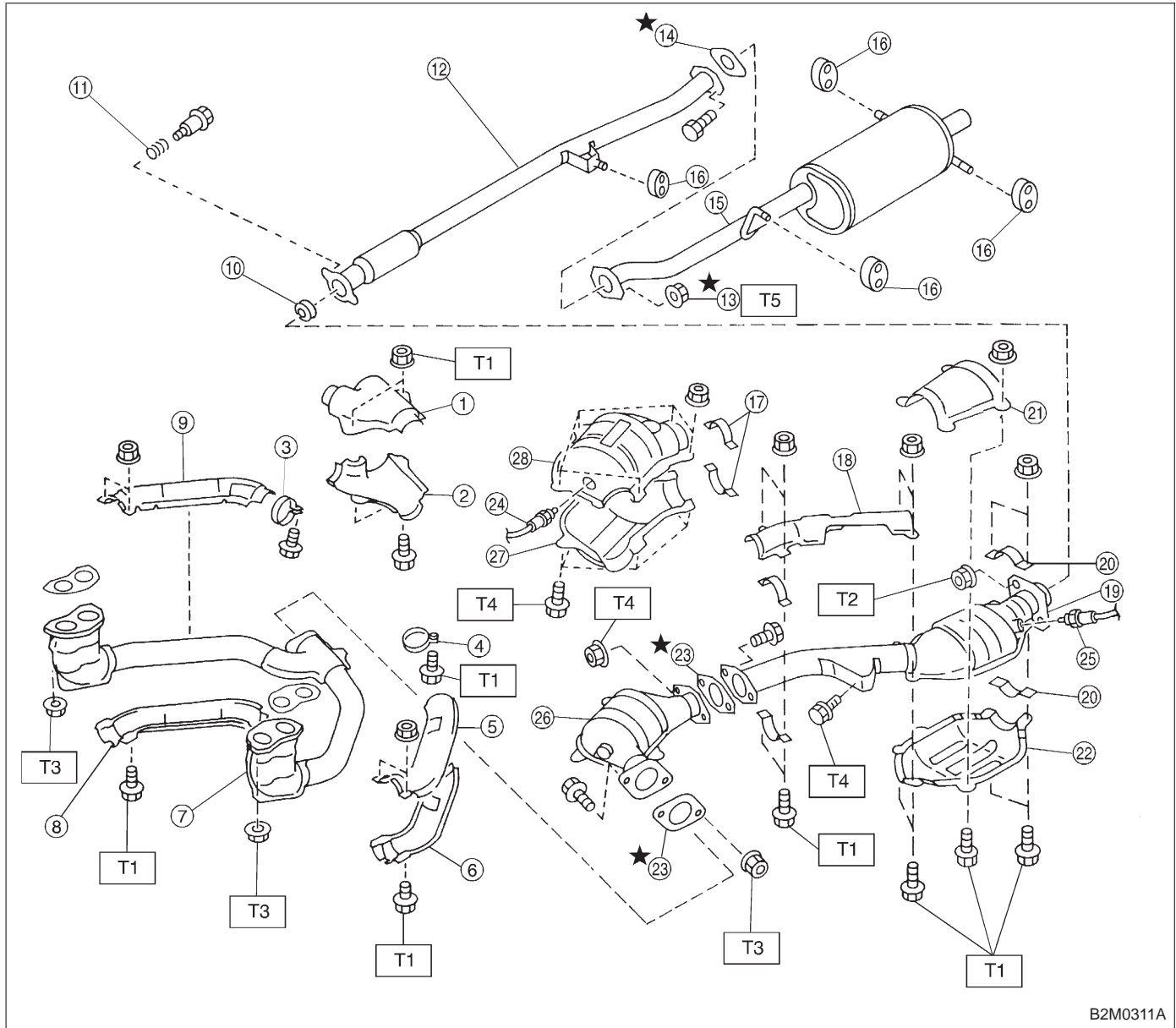

B2M0311A

- ① Upper front exhaust pipe cover CTR
- ② Lower front exhaust pipe cover CTR
- ③ Band RH
- ④ Band LH
- ⑤ Upper front exhaust pipe cover LH
- ⑥ Lower front exhaust pipe cover LH
- ⑦ Front exhaust pipe
- ⑧ Lower front exhaust pipe cover RH
- ⑨ Upper front exhaust pipe cover RH
- ⑩ Gasket
- ⑪ Spring
- ⑫ Rear exhaust pipe

- ⑬ Self-locking nut
- ⑭ Gasket
- ⑮ Muffler
- ⑯ Cushion rubber
- ⑰ Clamp
- ⑱ Upper center exhaust pipe cover
- ⑲ Center exhaust pipe
- ⑳ Clamp B
- ㉑ Upper rear catalytic converter cover
- ㉒ Lower rear catalytic converter cover
- ㉓ Gasket
- ㉔ Front oxygen sensor

- ㉕ Rear oxygen sensor
- ㉖ Front catalytic converter
- ㉗ Lower front catalytic converter cover
- ㉘ Upper front catalytic converter cover

**Tightening torque: N·m (kg·m, ft·lb)**

- T1: 13±3 (1.3±0.3, 9.4±2.2)**
- T2: 18±5 (1.8±0.5, 13.0±3.6)**
- T3: 30±5 (3.1±0.5, 22.4±3.6)**
- T4: 35±5 (3.6±0.5, 26.0±3.6)**
- T5: 48±5 (4.9±0.5, 35.4±3.6)**

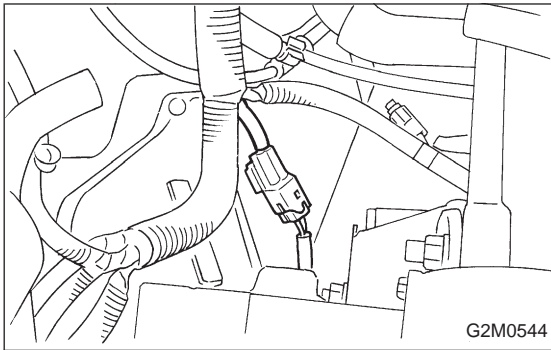

## 1. Front Exhaust Pipe and Center Exhaust Pipe

### A: REMOVAL

1) Disconnect front oxygen sensor connector.

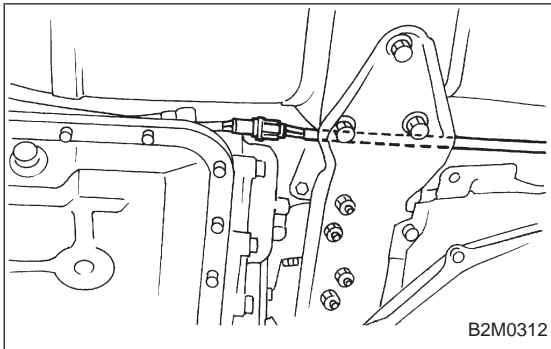

2) Lift-up the vehicle.

3) Disconnect rear oxygen sensor connector.

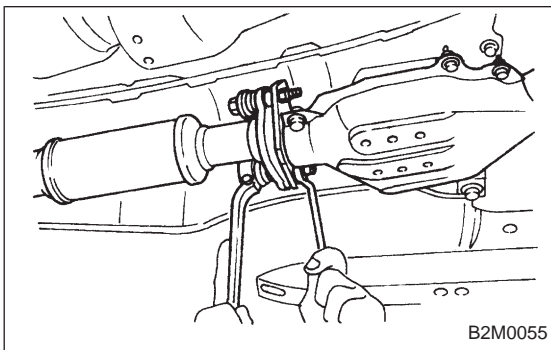

4) Separate center exhaust pipe from rear exhaust pipe.

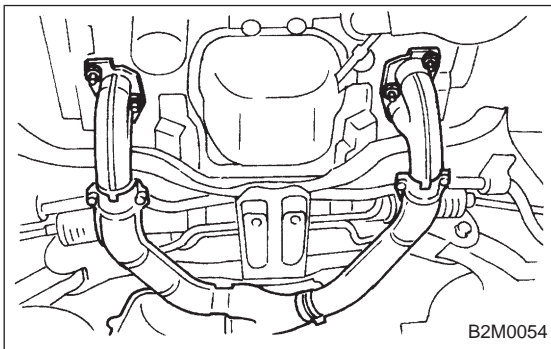

5) Remove bolts which hold front exhaust pipe onto cylinder heads.

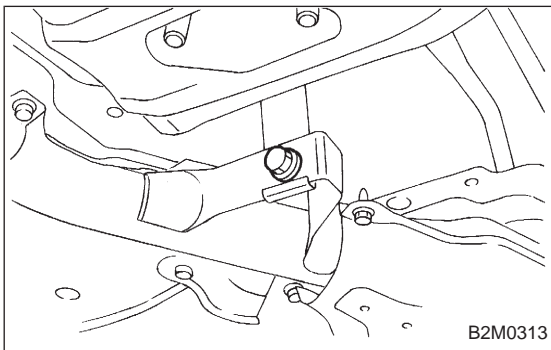

6) Remove front exhaust pipe and center exhaust pipe from hanger bracket.

### CAUTION:

**Be careful not to pull down front exhaust pipe and center exhaust pipe.**

## 1. Front Exhaust Pipe and Center Exhaust Pipe

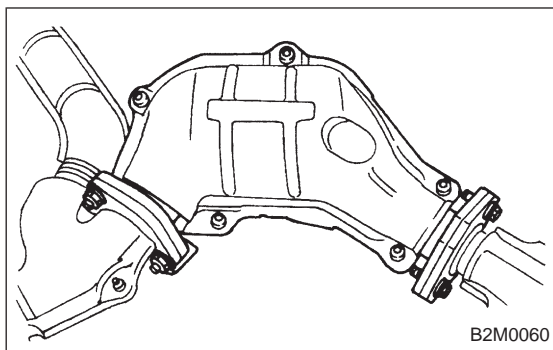

7) Separate front exhaust pipe from front catalytic converter.

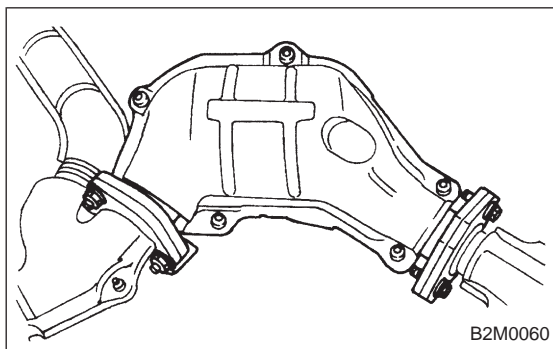
**B: INSTALLATION****CAUTION:**

Replace gaskets with new ones.

1) Install front catalytic converter to front exhaust pipe.

**Tightening torque:**

$30 \pm 5 \text{ N}\cdot\text{m}$  ( $3.1 \pm 0.5 \text{ kg}\cdot\text{m}$ ,  $22.4 \pm 3.6 \text{ ft}\cdot\text{lb}$ )

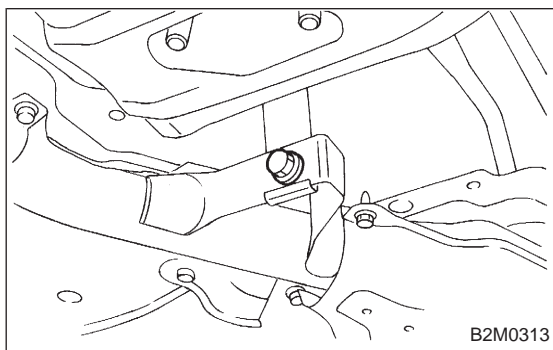

2) Install front exhaust pipe and center exhaust pipe. And temporarily tighten bolt which installs center exhaust pipe to hanger bracket.

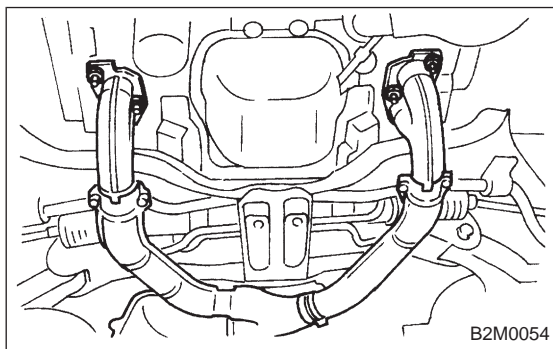

3) Tighten bolts which hold front exhaust pipe onto cylinder heads.

**Tightening torque:**

$30 \pm 5 \text{ N}\cdot\text{m}$  ( $3.1 \pm 0.5 \text{ kg}\cdot\text{m}$ ,  $22.4 \pm 3.6 \text{ ft}\cdot\text{lb}$ )

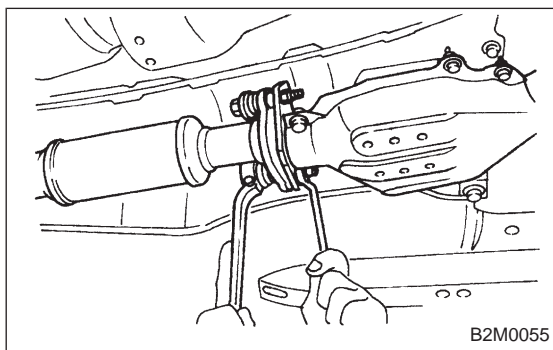

4) Install center exhaust pipe to rear exhaust pipe.

**Tightening torque:**

$18 \pm 5 \text{ N}\cdot\text{m}$  ( $1.8 \pm 0.5 \text{ kg}\cdot\text{m}$ ,  $13.0 \pm 3.6 \text{ ft}\cdot\text{lb}$ )

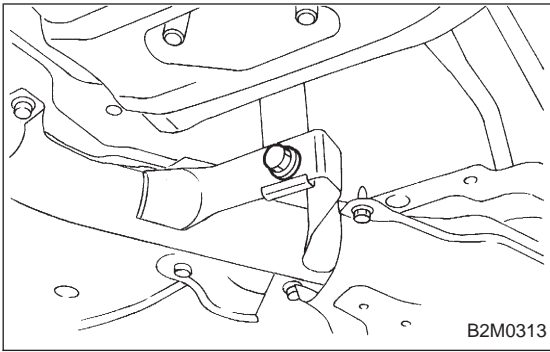

5) Tighten bolt which holds center exhaust pipe to hanger bracket.

**Tightening torque:**

**$35\pm 5$  N·m ( $3.6\pm 0.5$  kg·m,  $26.0\pm 3.6$  ft·lb)**

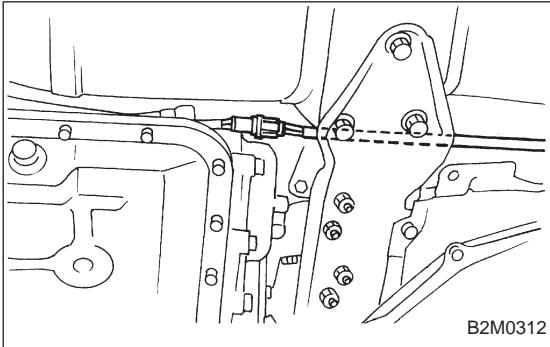

6) Connect rear oxygen sensor connector.

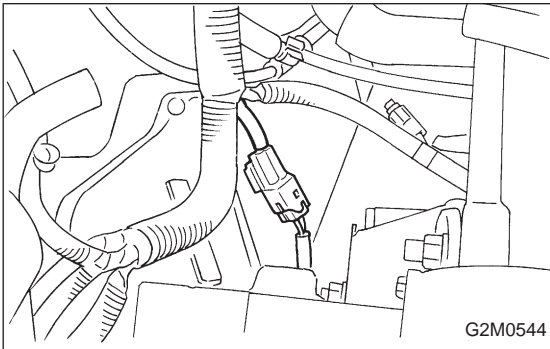

7) Lower the vehicle.

8) Connect front oxygen sensor connector.

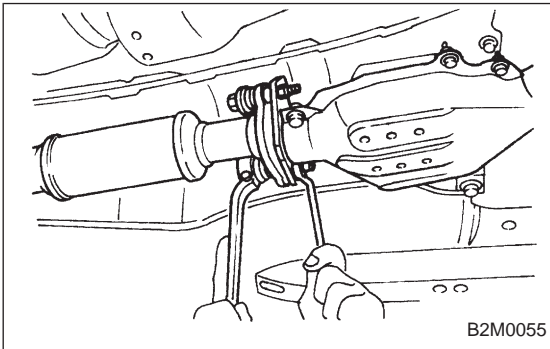

## 2. Rear Exhaust Pipe

### A: REMOVAL

1) Separate rear exhaust pipe from center exhaust pipe.

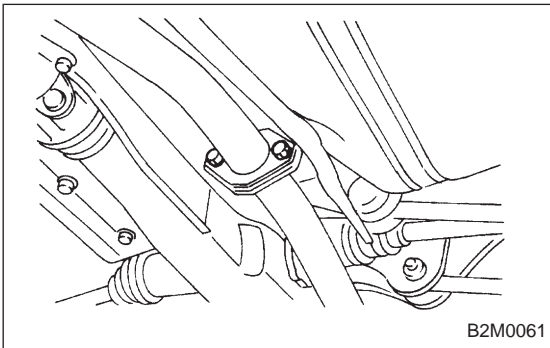

2) Separate rear exhaust pipe from muffler.

**CAUTION:**

**Be careful not to pull down rear exhaust pipe.**

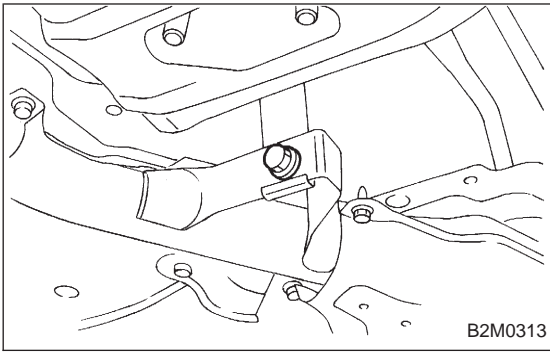

5) Tighten bolt which holds center exhaust pipe to hanger bracket.

**Tightening torque:**

**$35\pm 5$  N·m ( $3.6\pm 0.5$  kg·m,  $26.0\pm 3.6$  ft·lb)**

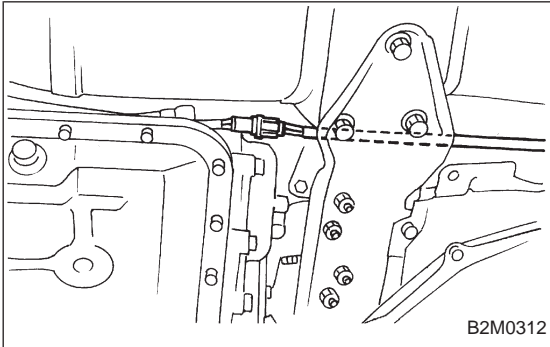

6) Connect rear oxygen sensor connector.

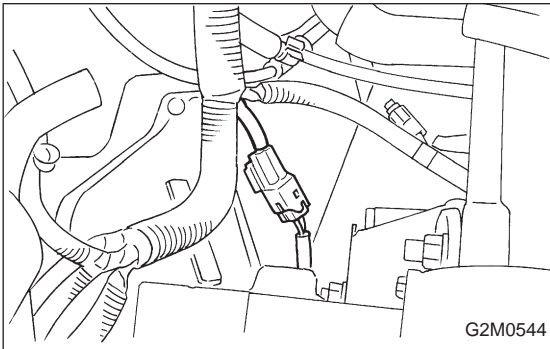

7) Lower the vehicle.

8) Connect front oxygen sensor connector.

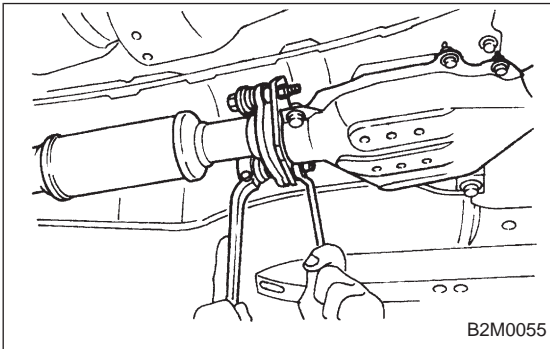

## 2. Rear Exhaust Pipe

### A: REMOVAL

1) Separate rear exhaust pipe from center exhaust pipe.

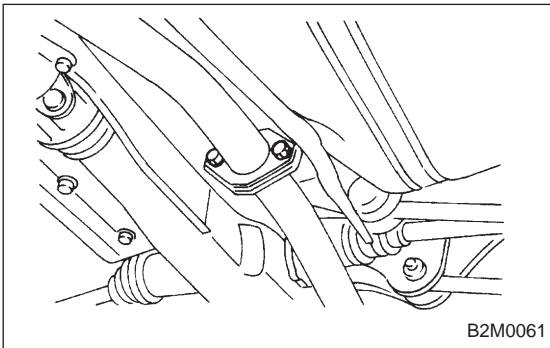

2) Separate rear exhaust pipe from muffler.

**CAUTION:**

**Be careful not to pull down rear exhaust pipe.**

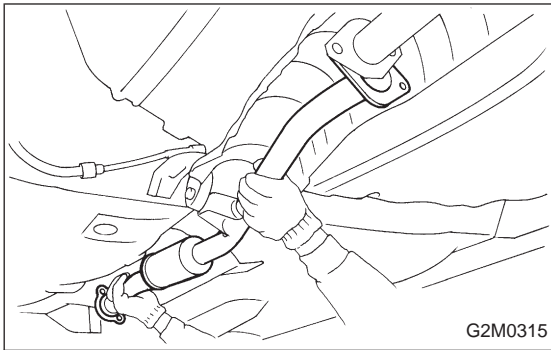

3) Remove rear exhaust pipe bracket from rubber cushion.

**NOTE:**

To facilitate removal, apply a coat of SUBARU CRC or equivalent to pipe bracket in advance.

***SUBARU CRC (Part No. 004301003)***

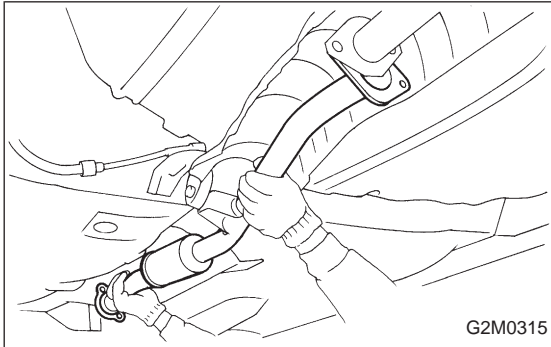

**B: INSTALLATION**

**CAUTION:**

**Replace gaskets with new ones.**

1) Install rear exhaust pipe bracket to rubber cushion.

**NOTE:**

To facilitate installation, apply a coat of SUBARU CRC or equivalent to mating area of rubber cushion in advance.

***SUBARU CRC (Part No. 004301003)***

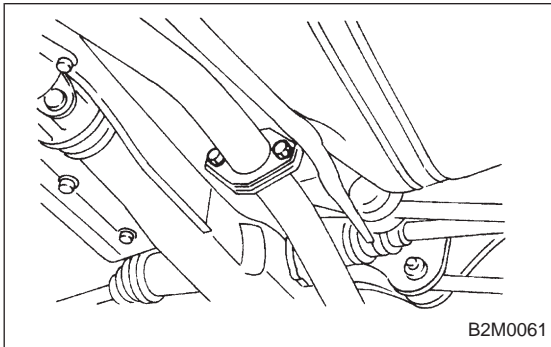

2) Install rear exhaust pipe to muffler.

**Tightening torque:**

***48±5 N·m (4.9±0.5 kg-m, 35.4±3.6 ft-lb)***

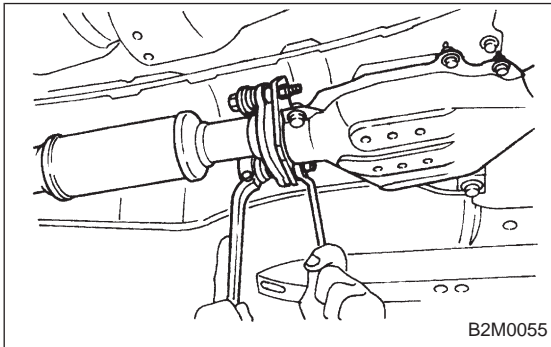

3) Install rear exhaust pipe to center exhaust pipe.

**Tightening torque:**

***18±5 N·m (1.8±0.5 kg-m, 13.0±3.6 ft-lb)***

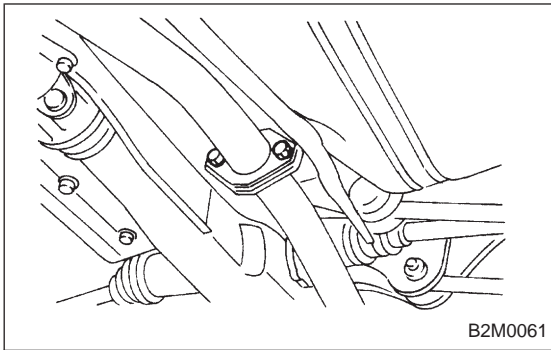

### 3. Muffler

#### A: REMOVAL AND INSTALLATION

1) Separate muffler from rear exhaust pipe.

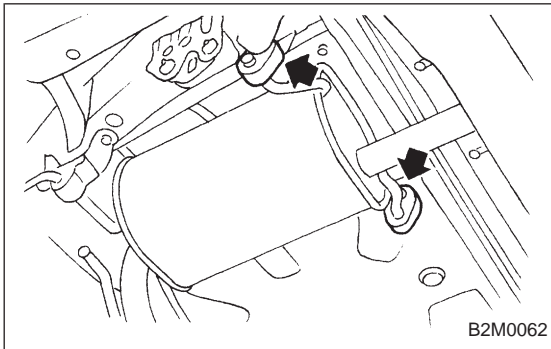

2) Remove left and right rubber cushions.

#### CAUTION:

**Be careful not to pull down muffler.**

#### NOTE:

To facilitate removal, apply a coat of SUBARU CRC or equivalent to mating area of rubber cushions in advance.

***SUBARU CRC (Part No. 004301003)***

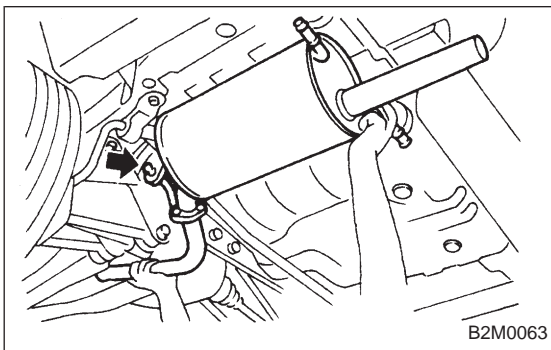

3) Remove front rubber cushion, and detach muffler assembly.

#### NOTE:

To facilitate removal, apply a coat of SUBARU CRC or equivalent to mating area of rubber cushion in advance.

***SUBARU CRC (Part No. 004301003)***

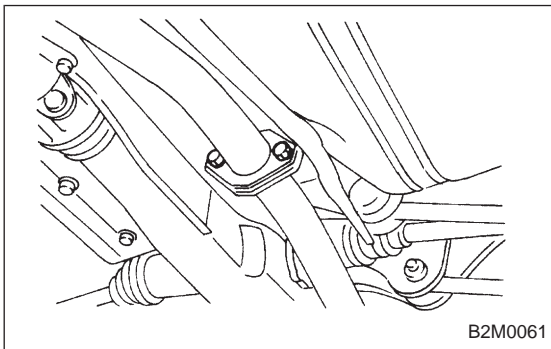

4) Installation is in the reverse order of removal.

#### CAUTION:

**Replace gasket with a new one.**

#### Tightening torque:

***48±5 N·m (4.9±0.5 kg-m, 35.4±3.6 ft-lb)***



**1. Clutch System****A: SPECIFICATIONS**

		2200 cc
Clutch cover	Diaphragm set load      kg (lb)	450 (992)
Clutch disc	Facing material	Woven
	O.D. x I.D. x thickness      mm (in)	225 x 150 x 3.5 (8.86 x 5.91 x 0.138)
	Spline O.D. (No. of teeth)                      mm (in)	25.2 (0.992) (24)
Clutch release lever ratio		3.0
Release bearing		Grease-packed self-aligning

**B: SERVICE DATA**

		2200 cc	
Clutch pedal	Full stroke                              mm (in)	140 — 150 (5.51 — 5.91)	
Release lever	Stroke                                      mm (in)	24 — 26 (0.94 — 1.02)	
	Play at release lever center              mm (in)	3 — 4 (0.12 — 0.16)	
Clutch disc	Depth of rivet head      mm (in)	Standard	1.3 — 1.9 (0.051 — 0.075)
		Limit of sinking	0.3 (0.012)
	Limit for runout                              mm (in)	1.0 (0.039) at R = 107 (4.21)	

1. Clutch System

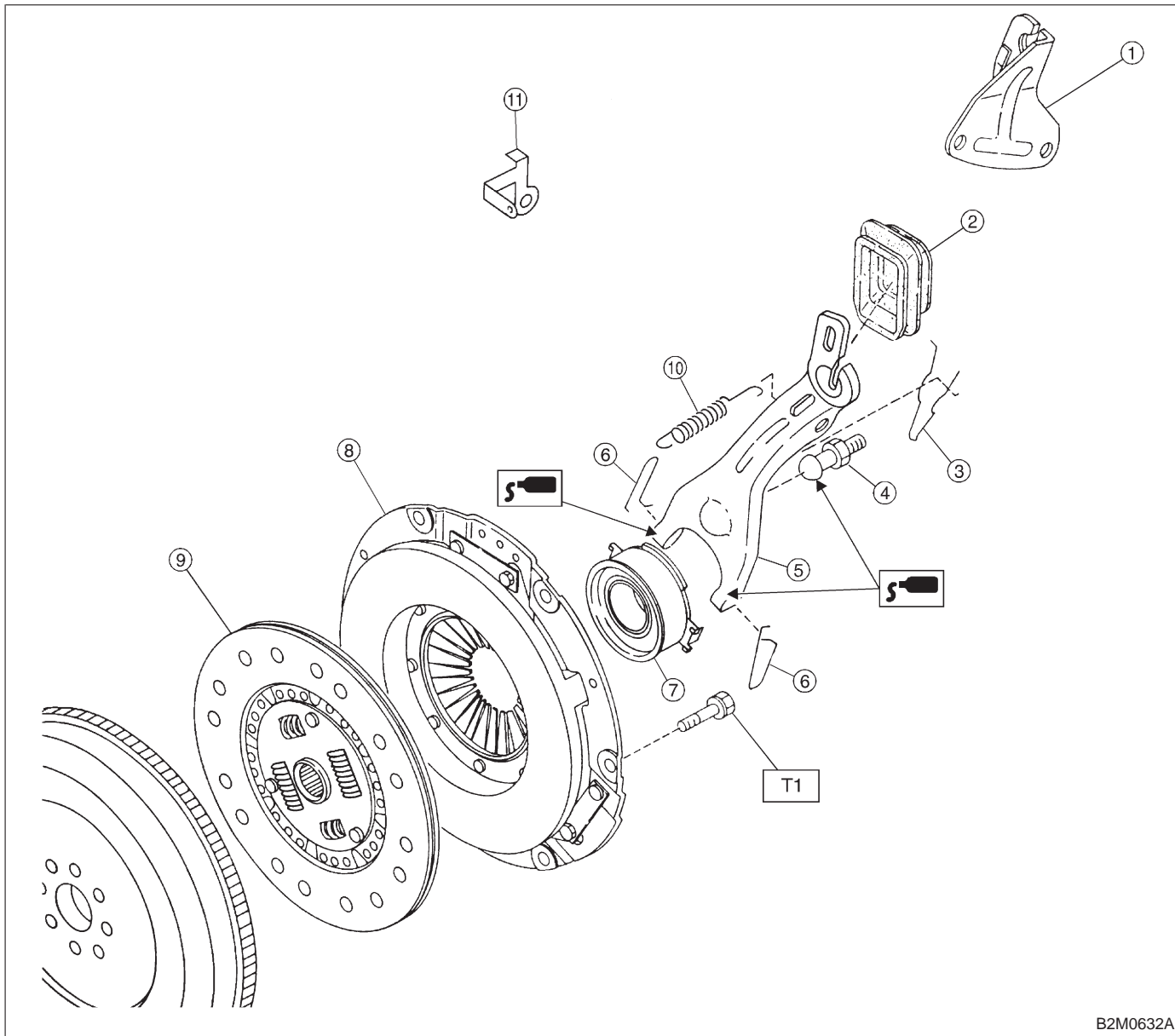

B2M0632A

- ① Clutch cable bracket
- ② Clutch release lever sealing
- ③ Retainer spring
- ④ Pivot
- ⑤ Clutch release lever
- ⑥ Clip
- ⑦ Clutch release bearing
- ⑧ Clutch cover

- ⑨ Clutch disc
- ⑩ Return spring (Models without hill holder only)
- ⑪ Clutch return spring bracket

**Tightening torque: N·m (kg·m, ft·lb)**  
**T1: 15.7±1.5 (1.6±0.15, 11.6±1.1)**

## 1. General

### A: PRECAUTION

When servicing clutch system, pay attention to the following items.

#### 1. MECHANICAL APPLICATION TYPE

- 1) Check the routing of clutch cable for smoothness.
- 2) Excessive tightness or looseness of clutch cable have a bad influence upon the cable durability.
- 3) Apply grease sufficiently to the connecting portion of clutch pedal.
- 4) Apply grease sufficiently to the release lever portion.
- 5) Position clutch cable through the center of toe board hole and route it smoothly. Adjustment is done by moving the outer cable.
- 6) Make sure not to let the clutch chatter when starting forward or rearward. If clutch chattering occurs, readjust so that the bend of clutch outer cable becomes flatter.

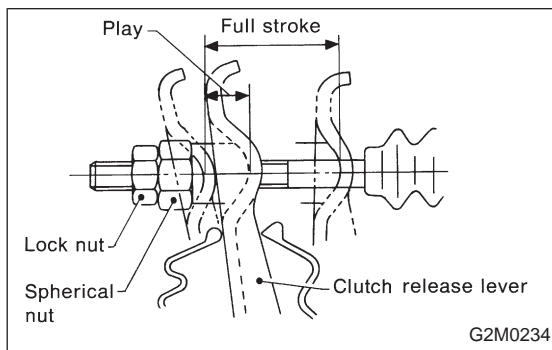

## 2. On-Car Service

### 1. MECHANICAL APPLICATION TYPE

- 1) Remove release lever return spring from lever (Models without hill holder only).
- 2) Adjust spherical nut so that the play is within the specified value at the lever end (center of spherical nut).

#### CAUTION:

**Take care not to twist the cable during adjustment**

**Play: 3 — 4 mm (0.12 — 0.16 in)**

**Full stroke: 24 — 26 mm (0.94 — 1.02 in)**

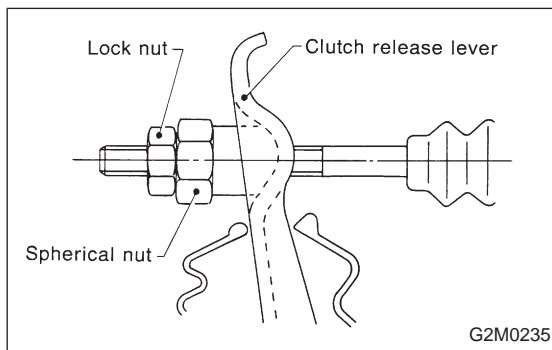

- 3) Upon completion of adjustment, securely lock spherical nut with lock nut.

Install return spring on lever (Models without hill holder only).

#### NOTE:

Hook the long hook side of the return spring with the lever (Models without hill holder only).

## 1. General

### A: PRECAUTION

When servicing clutch system, pay attention to the following items.

#### 1. MECHANICAL APPLICATION TYPE

- 1) Check the routing of clutch cable for smoothness.
- 2) Excessive tightness or looseness of clutch cable have a bad influence upon the cable durability.
- 3) Apply grease sufficiently to the connecting portion of clutch pedal.
- 4) Apply grease sufficiently to the release lever portion.
- 5) Position clutch cable through the center of toe board hole and route it smoothly. Adjustment is done by moving the outer cable.
- 6) Make sure not to let the clutch chatter when starting forward or rearward. If clutch chattering occurs, readjust so that the bend of clutch outer cable becomes flatter.

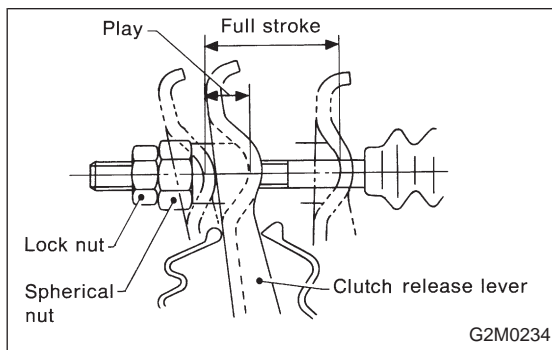

## 2. On-Car Service

### 1. MECHANICAL APPLICATION TYPE

- 1) Remove release lever return spring from lever (Models without hill holder only).
- 2) Adjust spherical nut so that the play is within the specified value at the lever end (center of spherical nut).

#### CAUTION:

**Take care not to twist the cable during adjustment**

**Play: 3 — 4 mm (0.12 — 0.16 in)**

**Full stroke: 24 — 26 mm (0.94 — 1.02 in)**

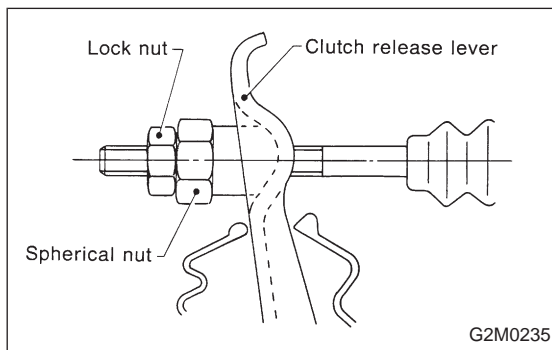

- 3) Upon completion of adjustment, securely lock spherical nut with lock nut.

Install return spring on lever (Models without hill holder only).

#### NOTE:

Hook the long hook side of the return spring with the lever (Models without hill holder only).

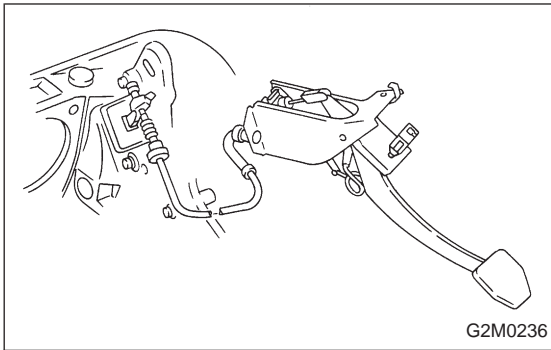

4) Depress clutch pedal to assure there is no abnormality in the clutch system.

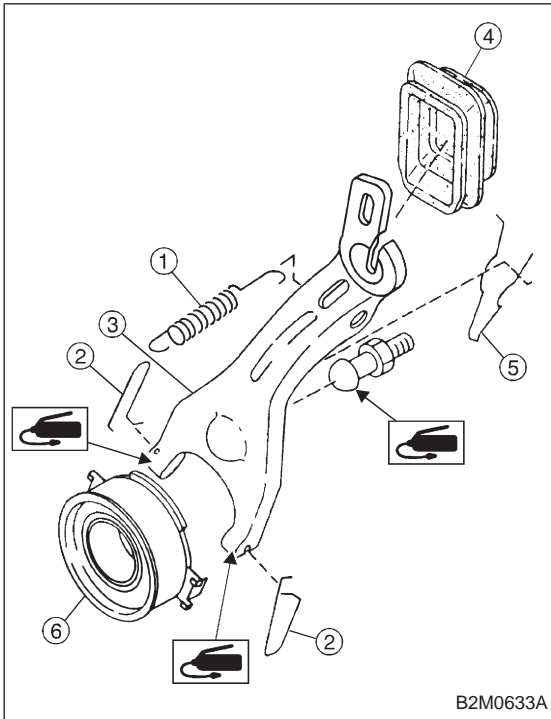

**3. Release Bearing and Lever**

**A: REMOVAL**

**1. MECHANICAL APPLICATION TYPE**

1) Remove release lever return spring ① (Models without hill holder only).

2) Remove the two clips ② from clutch release lever ③ and remove release bearing ⑥.

**CAUTION:**

**Be careful not to deform clips.**

3) Remove release lever seal ④.

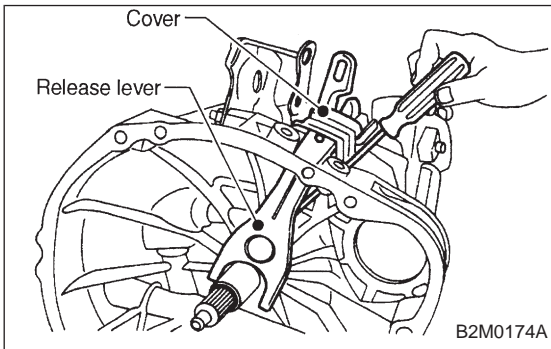

4) Remove release lever retainer spring from release lever pivot with a screwdriver by accessing it through clutch housing release lever hole. Then remove release lever.

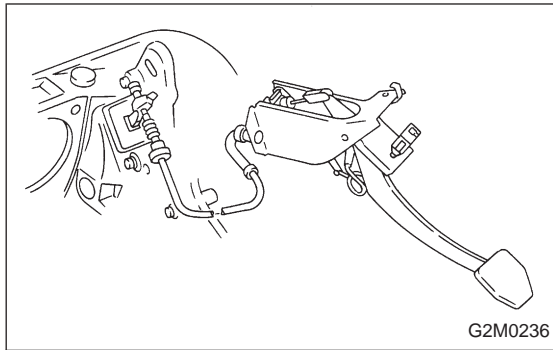

4) Depress clutch pedal to assure there is no abnormality in the clutch system.

### 3. Release Bearing and Lever

#### A: REMOVAL

##### 1. MECHANICAL APPLICATION TYPE

1) Remove release lever return spring ① (Models without hill holder only).

2) Remove the two clips ② from clutch release lever ③ and remove release bearing ⑥.

**CAUTION:**

**Be careful not to deform clips.**

3) Remove release lever seal ④.

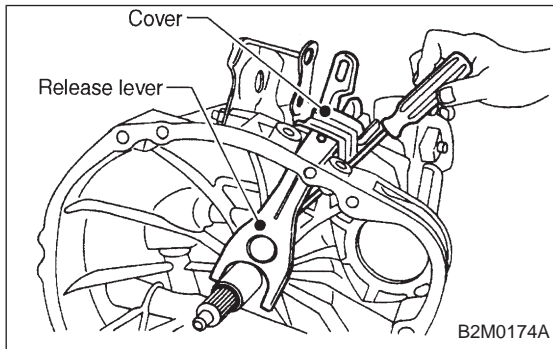
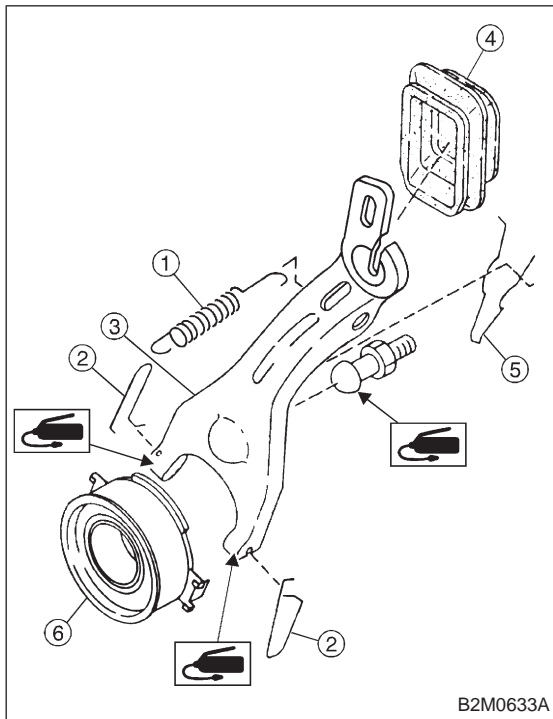

4) Remove release lever retainer spring from release lever pivot with a screwdriver by accessing it through clutch housing release lever hole. Then remove release lever.

## 3. Release Bearing and Lever

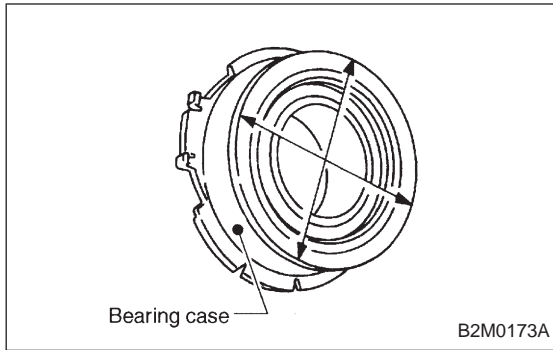
**B: INSPECTION****1. RELEASE BEARING****CAUTION:**

Since this bearing is grease sealed and is of a nonlubrication type, do not wash with gasoline or any solvent when servicing the clutch.

1) Check the bearing for smooth movement by applying force in the radial direction.

**Radial direction stroke:**

**FWD; Approx.**  
1.0 mm (0.039 in)

**AWD; Approx.**  
1.4 mm (0.055 in)

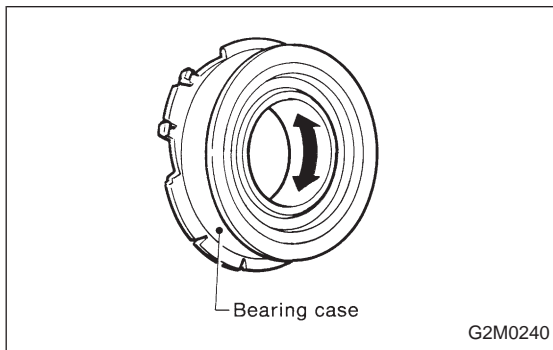

2) Check the bearing for smooth rotation by applying pressure in the thrust direction.

3) Check wear and damage of bearing case surface contacting with lever.

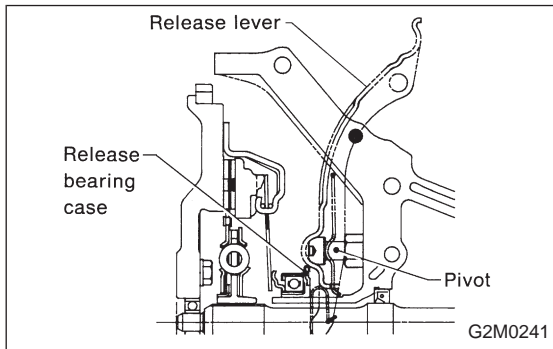
**2. RELEASE LEVER**

Check lever pivot portion and the point of contact with release bearing case for wear.

**C: INSTALLATION****CAUTION:**

Before or during assembling, lubricate the following points with a light coat of grease.

- Inner groove of release bearing
- Contact surface of lever and pivot
- Contact surface of lever and bearing
- Transmission main shaft spline (Use grease containing molybdenum disulphide.)

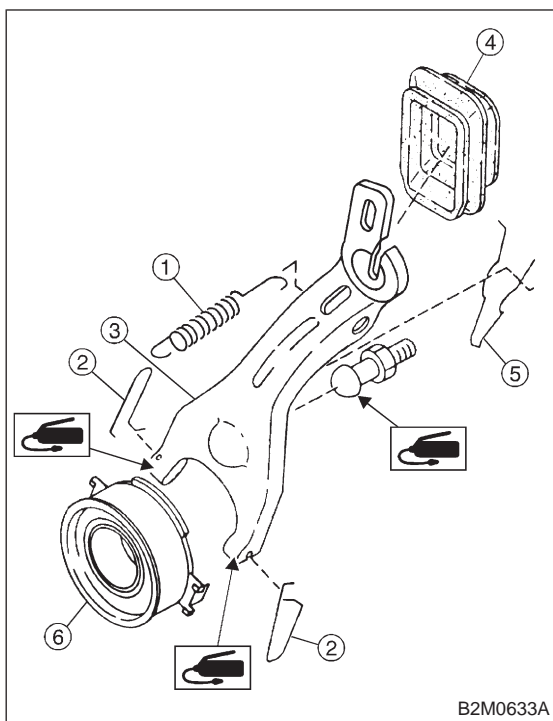

**1. MECHANICAL APPLICATION TYPE**

1) While pushing release lever ③ to pivot and twisting it to both sides, fit retainer spring ⑤ onto the constricted portion of pivot.

**NOTE:**

Confirm that retainer spring is securely fitted by observing it through the main case hole.

2) Install release bearing ⑥ and fasten it with two clips ②.  
3) Install release lever seal ④.

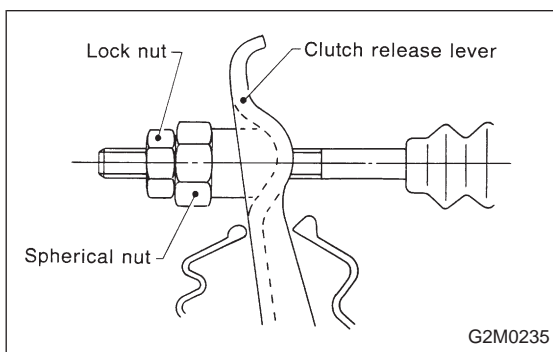

4) After remounting engine and transmission on body, make adjustment of the clutch release lever end play.

**CAUTION:**

**Take care not to twist the cable during adjustment.**

5) Install release lever return spring (Models without hill holder only).

**NOTE:**

Hook up the return spring to right side hole of the release lever.

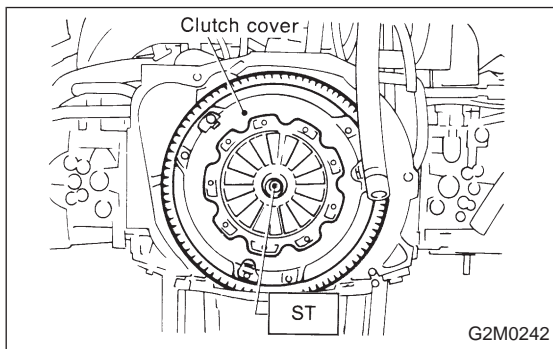

**4. Clutch Disc and Cover**

**A: REMOVAL**

1) Install ST on flywheel.

ST 498497100 CRANKSHAFT STOPPER

2) Remove clutch cover and clutch disc.

**CAUTION:**

- Take care not to allow oil on the clutch disc facing.
- Do not disassemble either clutch cover or clutch disc.

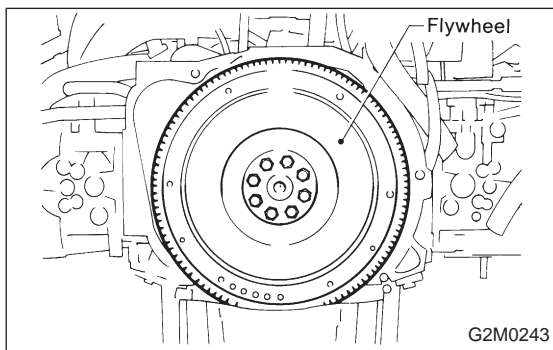

3) Remove flywheel.



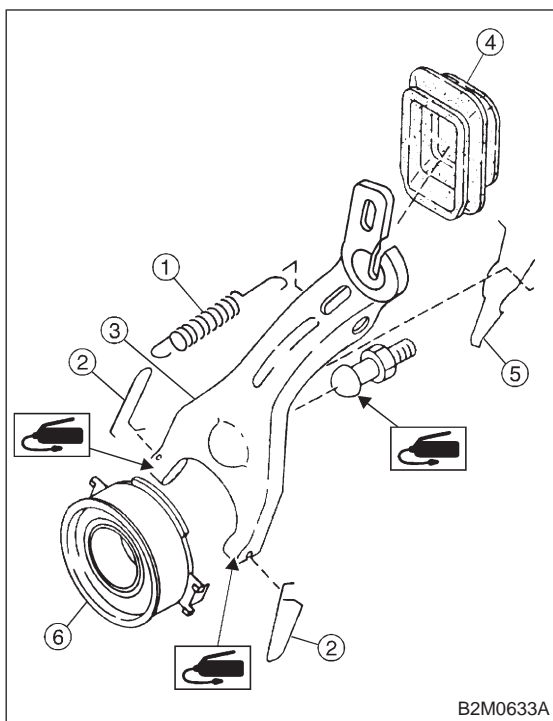

**1. MECHANICAL APPLICATION TYPE**

1) While pushing release lever ③ to pivot and twisting it to both sides, fit retainer spring ⑤ onto the constricted portion of pivot.

**NOTE:**

Confirm that retainer spring is securely fitted by observing it through the main case hole.

- 2) Install release bearing ⑥ and fasten it with two clips ②.
- 3) Install release lever seal ④.

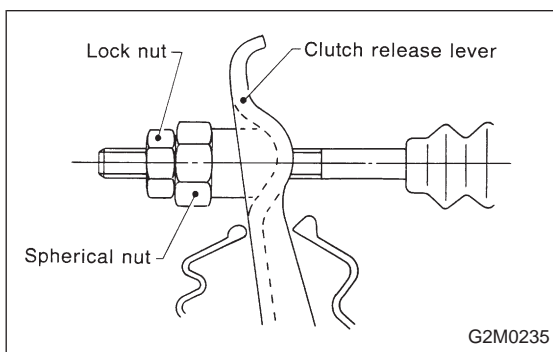

4) After remounting engine and transmission on body, make adjustment of the clutch release lever end play.

**CAUTION:**

**Take care not to twist the cable during adjustment.**

5) Install release lever return spring (Models without hill holder only).

**NOTE:**

Hook up the return spring to right side hole of the release lever.

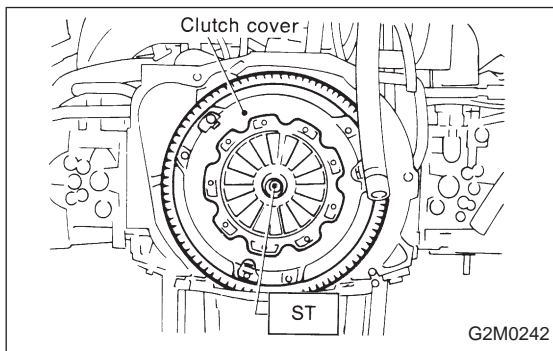

**4. Clutch Disc and Cover**

**A: REMOVAL**

- 1) Install ST on flywheel.  
ST 498497100 CRANKSHAFT STOPPER
- 2) Remove clutch cover and clutch disc.

**CAUTION:**

- Take care not to allow oil on the clutch disc facing.
- Do not disassemble either clutch cover or clutch disc.

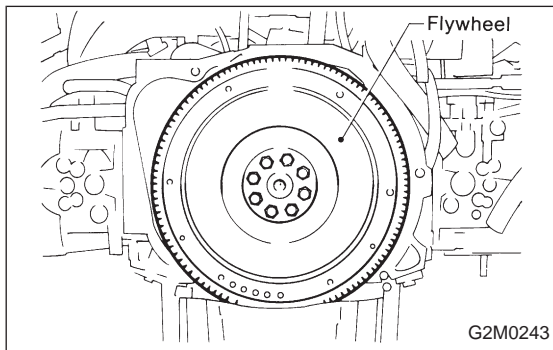

3) Remove flywheel.

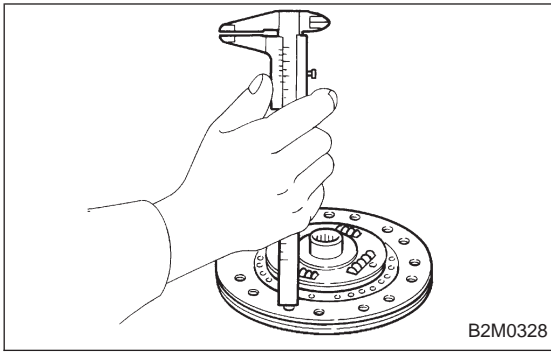
**B: INSPECTION****1. CLUTCH DISC**

## 1) Facing wear

Measure the depth of rivet head from the surface of facing. Replace if facings are worn locally or worn down to less than the specified value.

**Depth of rivet head:****Standard value**

**1.3 — 1.9 mm (0.051 — 0.075 in)**

**Limit of sinking**

**0.3 mm (0.012 in)**

**CAUTION:**

**Do not wash clutch disc with any cleaning fluid.**

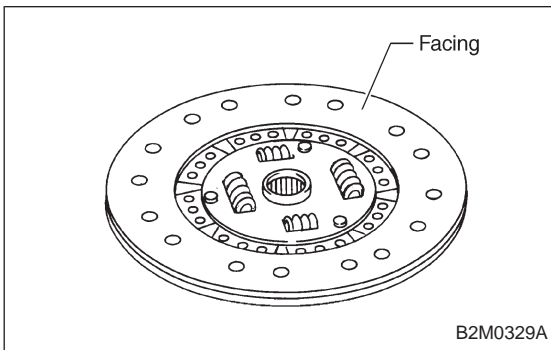

## 2) Hardened facing

Correct by using emery paper or replace.

## 3) Oil soakage on facing

Replace clutch disc and inspect transmission front oil seal, transmission case mating surface, engine rear oil seal and other points for oil leakage.

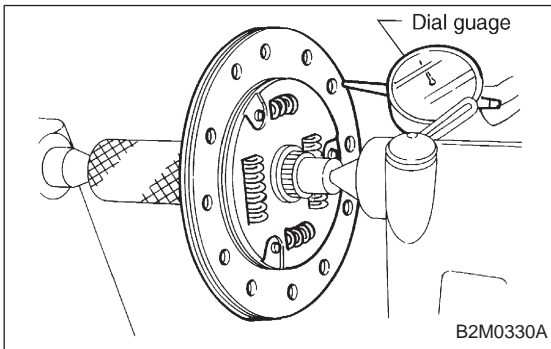

## 4) Deflection on facing

If deflection exceeds the specified value at the outer circumference of facing, repair or replace.

**Limit for deflection:**

**1.0 mm (0.039 in) at R = 107 mm (4.21 in)**

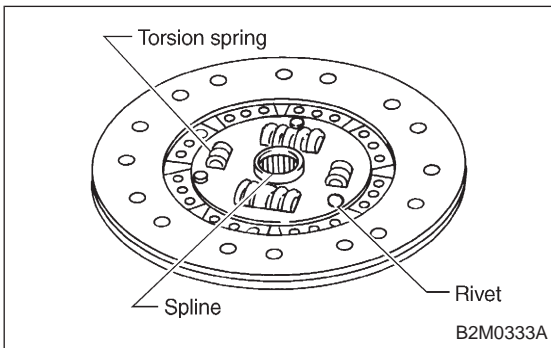

## 5) Worn spline, loose rivets and torsion spring failure

Replace defective parts.

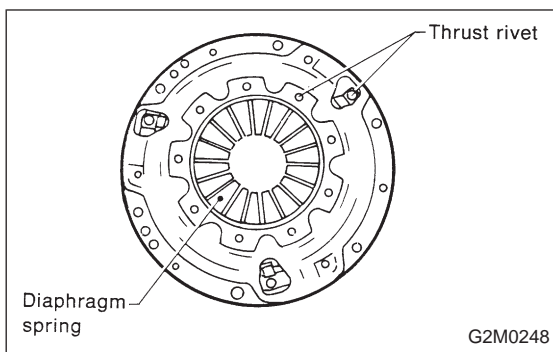

**2. CLUTCH COVER**

Visually check for the following items without disassembling, and replace or repair if defective.

- 1) Loose thrust rivet.
- 2) Damaged or worn bearing contact area at center of diaphragm spring.

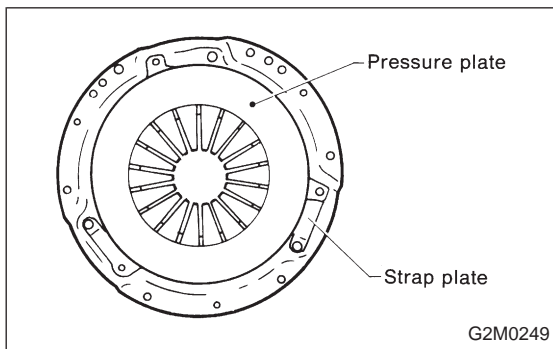

- 3) Damaged or worn disc contact surface of pressure plate.
- 4) Loose strap plate setting bolt.
- 5) Worn diaphragm sliding surface.

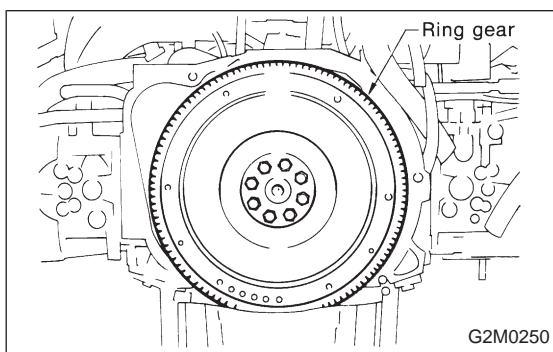

**3. FLYWHEEL**

**CAUTION:**

Since this bearing is grease sealed and is of a nonlubrication type, do not wash with gasoline or any solvent.

- 1) Damage of facing and ring gear  
If defective, replace flywheel.

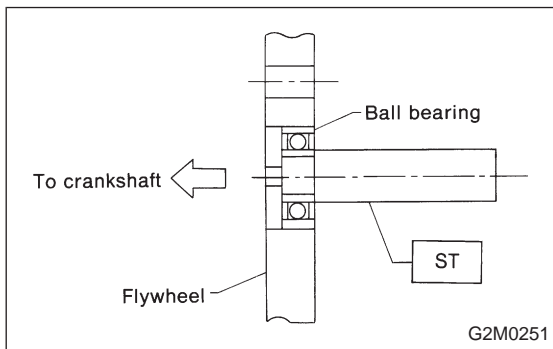

- 2) Smoothness of rotation  
Rotate ball bearing applying pressure in thrust direction.  
If noise or excessive play is noted, replace ball bearing as follows:

- (1) Drive out ball bearing from flywheel.
- (2) Press bearing into flywheel until bearing end surface is flush with clutch disc contact surface of flywheel.  
Do not press inner race.

ST 899754112 SNAP RING PRESS

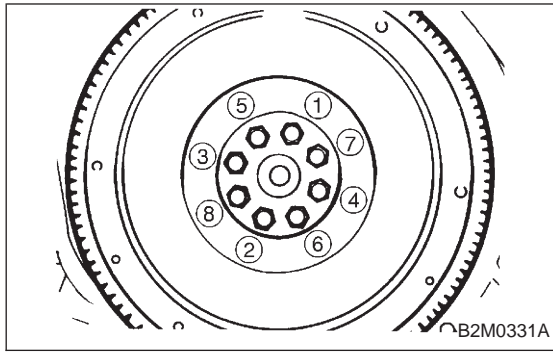
**C: INSTALLATION**

- 1) Install flywheel.
- 2) Install ST, and tighten the flywheel attaching bolts to the specified torque.

ST 498497100 CRANKSHAFT STOPPER

**Tightening torque:**

$72 \pm 3 \text{ N}\cdot\text{m}$  ( $7.3 \pm 0.3 \text{ kg}\cdot\text{m}$ ,  $52.8 \pm 2.2 \text{ ft}\cdot\text{lb}$ )

**NOTE:**

Tighten flywheel installing bolts gradually. Each bolt should be tightened to the specified torque in a crisscross fashion.

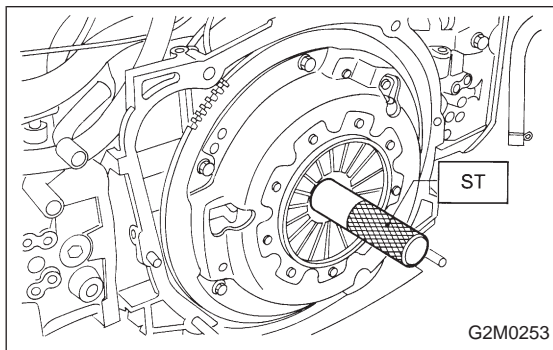
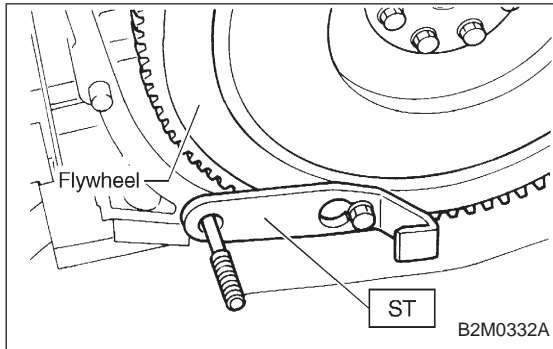

- 3) Insert ST into the clutch disc and install them on the flywheel by inserting the ST end into the pilot bearing.

ST 499747100 CLUTCH DISC GUIDE

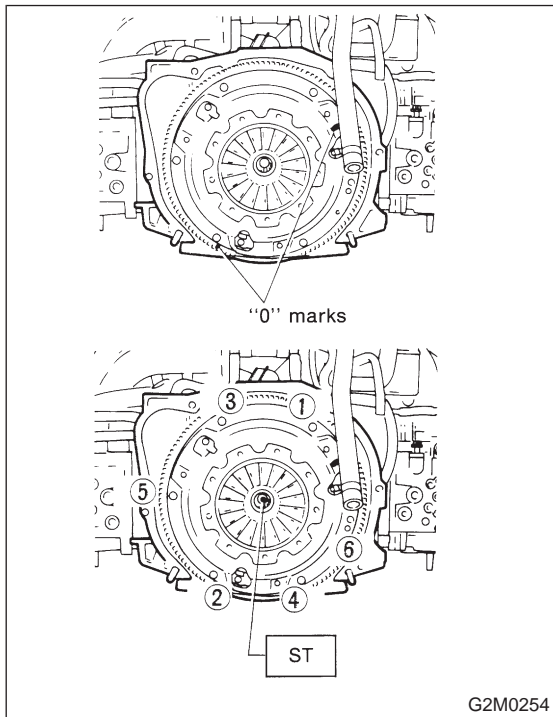

- 4) Install clutch cover on flywheel and tighten bolts to the specified torque.

**NOTE:**

- When installing the clutch cover on the flywheel, position the clutch cover so that there is a gap of 120° or more between "0" marks on the flywheel and clutch cover. ("0" marks indicate the directions of residual unbalance.)
- Note the front and rear of the clutch disc when installing.
- Tighten clutch cover installing bolts gradually. Each bolt should be tightened to the specified torque in a crisscross fashion.

**Tightening torque:**

$15.7 \pm 1.5 \text{ N}\cdot\text{m}$  ( $1.6 \pm 0.15 \text{ kg}\cdot\text{m}$ ,  $11.6 \pm 1.1 \text{ ft}\cdot\text{lb}$ )

- 5) Remove ST.

ST 499747100 CLUTCH DISC GUIDE

## 1. Clutch System

Condition	Possible cause and testing	Corrective action
1. Clutch slip-page	It is hard to perceive clutch slippage in the early stage, but pay attention to the following symptoms.	
	<p>(a) Engine revs up when shifting.</p> <p>(b) High speed driving is impossible; especially rapid acceleration impossible and vehicle speed does not increase in proportion to an increase in engine speed.</p> <p>(c) Power falls, particularly when ascending a slope, and there is a smell of burning of the clutch facing.</p> <p>● Method of testing: Put the vehicle in stationary condition with parking brake fully applied. Disengage the clutch and shift the transmission gear into the first. Gradually allow the clutch to engage while gradually increasing the engine speed. The clutch function is satisfactory if the engine stalls. However, the clutch is slipping if the vehicle does not start off and the engine does not stall.</p>	
2. Clutch drags.	<p>(a) No clutch pedal play</p> <p>(b) No release lever end play</p> <p>(c) Clutch facing smeared by oil</p> <p>(d) Worn clutch facing</p> <p>(e) Deteriorated diaphragm spring</p> <p>(f) Distorted pressure plate or flywheel</p> <p>(g) Defective release bearing holder</p> <p>(h) Defective pedal and cable system</p>	
	<p>Readjust.</p> <p>Readjust.</p> <p>Replace.</p> <p>Replace.</p> <p>Replace.</p> <p>Correct or replace.</p> <p>Correct or replace.</p> <p>Correct or replace.</p>	
3. Clutch chatters.	As a symptom of this trouble, a harsh scratching noise develops and control becomes quite difficult when shifting gears. The symptom becomes more apparent when shifting into the first gear. However, because much trouble of this sort is due to defective synchronization mechanism, carry out the test as described after.	
	<p>● Method of testing: Refer to DIAGNOSTIC DIAGRAM on page after.</p> <p>It may be judged as insufficient disengagement of clutch if any noise occurs during this test.</p>	
3. Clutch chatters.	<p>(a) Excessive clutch pedal play</p> <p>(b) Excessive clutch release lever play</p> <p>(c) Worn or rusty clutch disc hub spline</p> <p>(d) Excessive deflection of clutch disc facing</p> <p>(e) Seized crankshaft pilot needle bearing</p> <p>(f) Malfunction of pedal and cable system</p> <p>(g) Cracked clutch disc facing</p> <p>(h) Sticked clutch disc (smeared by oil or water)</p>	
	<p>Readjust.</p> <p>Readjust.</p> <p>Replace clutch disc.</p> <p>Correct or replace.</p> <p>Replace.</p> <p>Correct or replace.</p> <p>Replace.</p> <p>Replace.</p>	
3. Clutch chatters.	Clutch chattering is an unpleasant vibration to the whole body when the vehicle is just started with clutch partially engaged.	
	<p>(a) Improper clutch cable routing</p> <p>(b) Adhesion of oil on the facing</p> <p>(c) Weak or broken torsion spring</p> <p>(d) Defective facing contact or excessive disc</p> <p>(e) Warped pressure plate or flywheel</p> <p>(f) Loose disc rivets</p> <p>(g) Loose engine mounting</p> <p>(h) Improper adjustment of pitching stopper</p>	
3. Clutch chatters.	<p>Correct.</p> <p>Replace clutch disc.</p> <p>Replace clutch disc.</p> <p>Replace clutch disc deflection.</p> <p>Correct or replace.</p> <p>Replace clutch disc.</p> <p>Retighten or replace mounting.</p> <p>Adjustment.</p>	

Condition	Possible cause and testing	Corrective action
4. Noisy clutch	Examine whether the noise is generated when the clutch is disengaged, engaged, or partially engaged.	
	(a) Broken, worn or unlubricated release bearing	Replace release bearing.
	(b) Insufficient lubrication of pilot bearing	Apply grease.
	(c) Loose clutch disc hub	Replace clutch disc.
	(d) Loose torsion spring retainer	Replace clutch disc.
	(e) Deteriorated or broken torsion spring	Replace clutch disc.
5. Clutch grabs.	When starting the vehicle with the clutch partially engaged, the clutch engages suddenly and the vehicle jumps instead of making a smooth start.	
	(a) Grease or oil on facing	Replace clutch disc.
	(b) Deteriorated cushioning spring	Replace clutch disc.
	(c) Worn or rusted spline of clutch disc or main	Take off rust, apply grease or replace clutch shaft disc or mainshaft.
	(d) Deteriorated or broken torsion spring	Replace clutch disc.
	(e) Loose engine mounting	Retighten or replace mounting.
	(f) Deteriorated diaphragm spring	Replace.

1. DIAGNOSTIC DIAGRAM OF CLUTCH DRAG

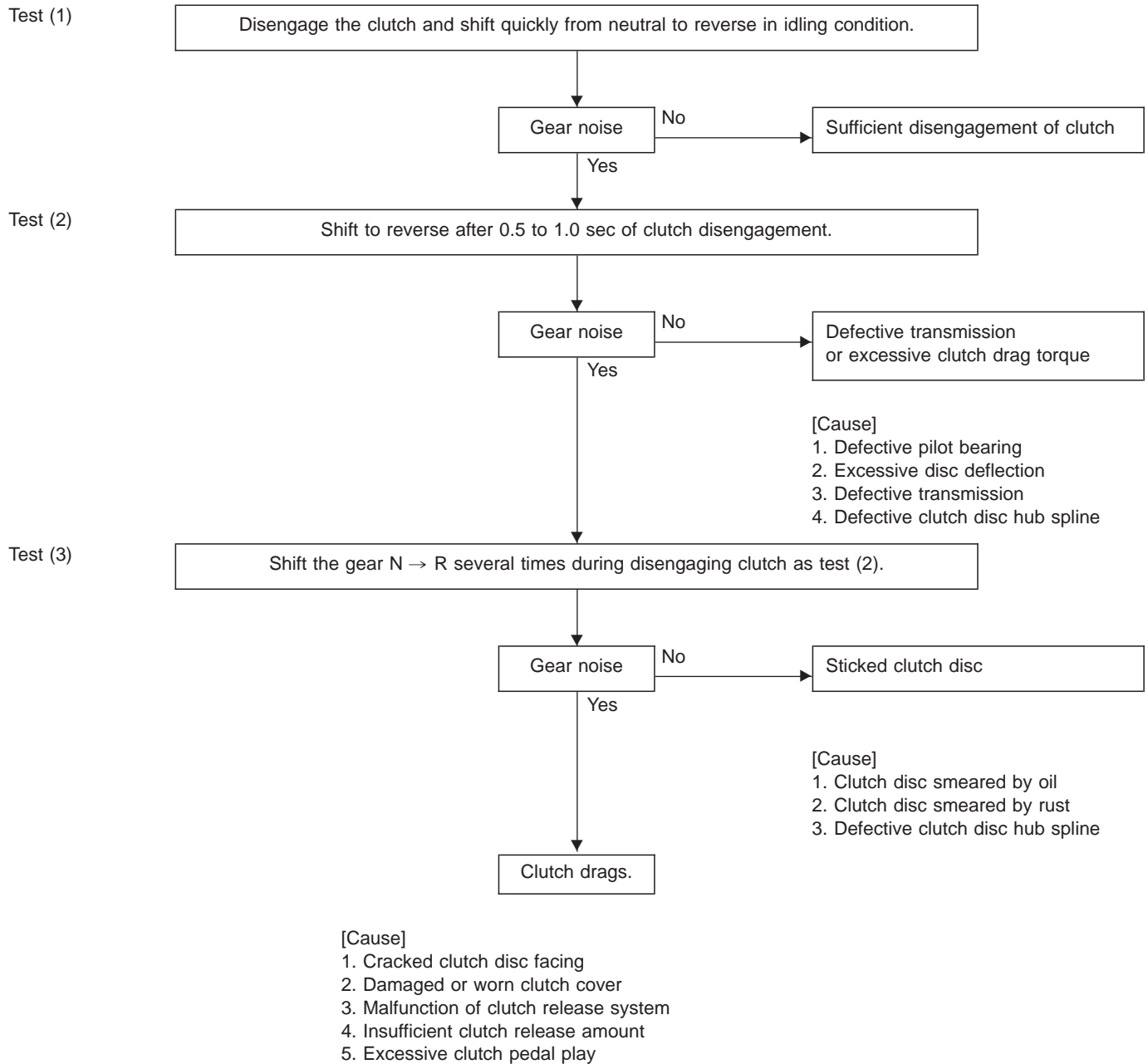

1. Engine Mounting

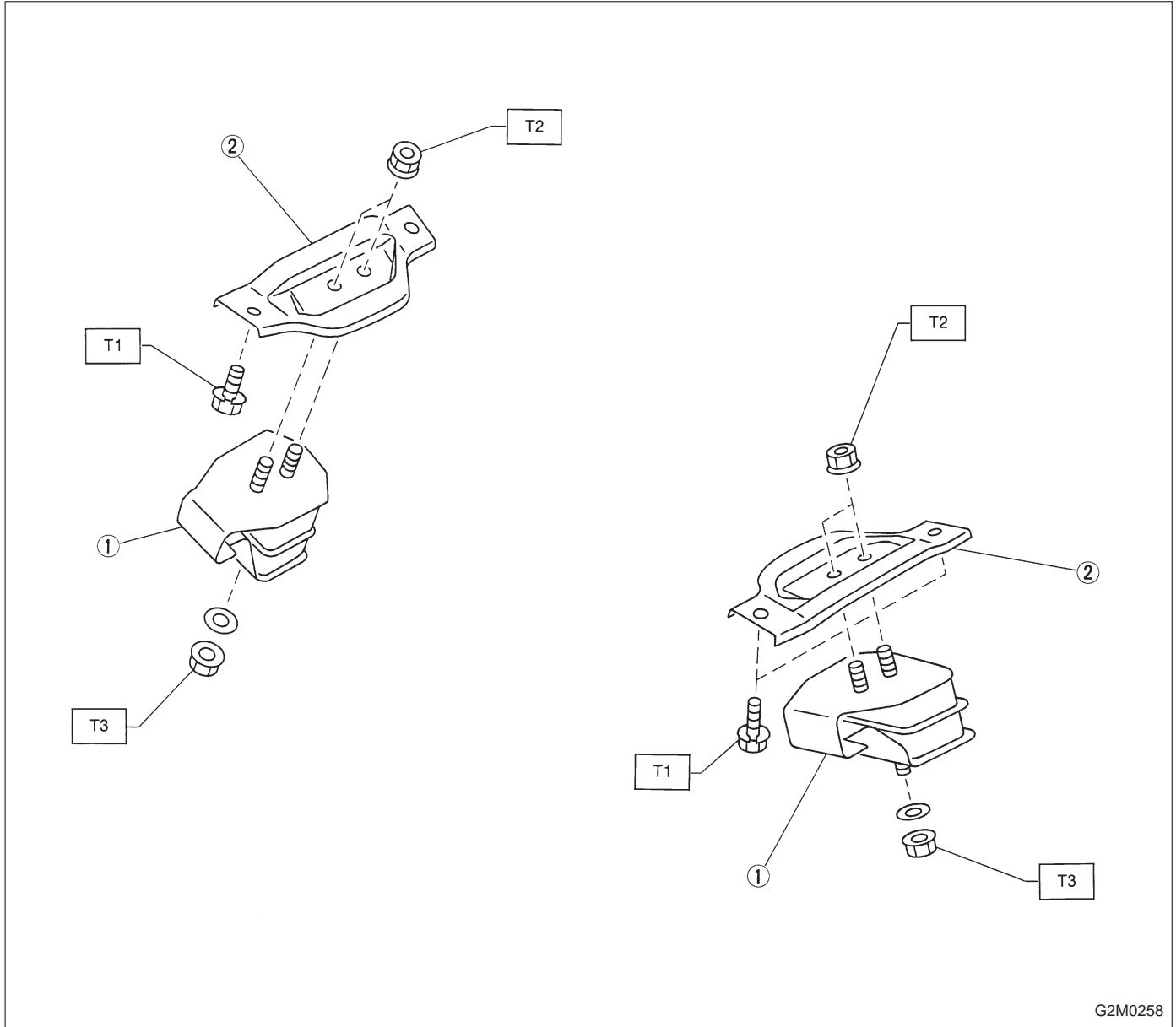

G2M0258

- ① Front cushion rubber
- ② Front engine mounting bracket

**Tightening torque: N.m (kg-m, ft-lb)**

**T1: 26±7 (2.7±0.7, 19.5±5.1)**

**T2: 41±10 (4.2±1.0, 30±7)**

**T3: 79±15 (8.0±1.5, 58±11)**



## 2. Transmission Mounting

### 1. MT MODEL

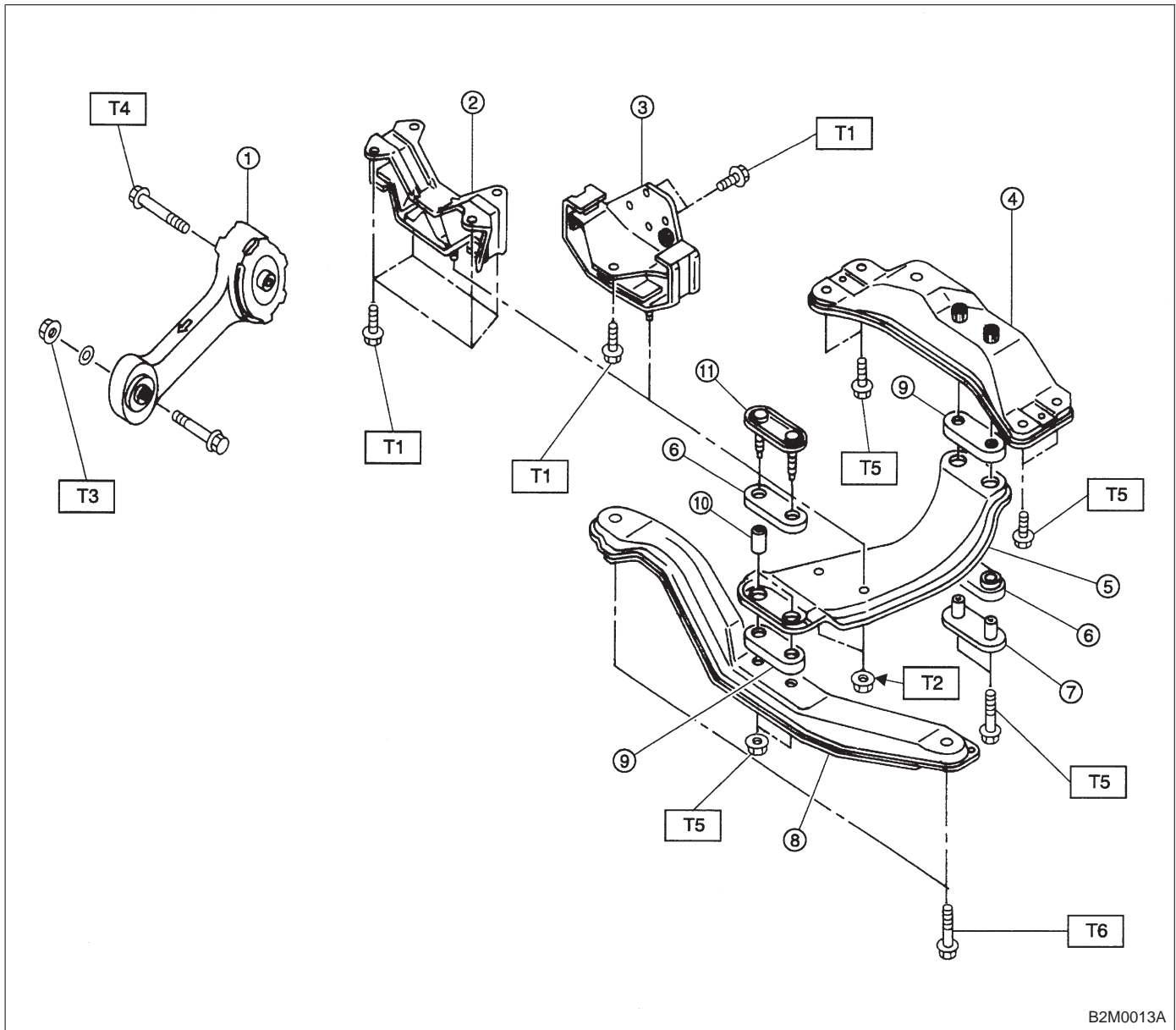

B2M0013A

- ① Pitching stopper
- ② Rear cushion rubber (AWD)
- ③ Rear cushion rubber (FWD)
- ④ Rear crossmember
- ⑤ Center crossmember
- ⑥ Cushion C
- ⑦ Rear plate
- ⑧ Front crossmember
- ⑨ Cushion D
- ⑩ Spacer
- ⑪ Front plate

**Tightening torque: N·m (kg·m, ft·lb)**

**T1: 33±5 (3.4±0.5, 24.6±3.6)**

**T2: 37±10 (3.8±1.0, 27±7)**

**T3: 49±5 (5.0±0.5, 36.2±3.6)**

**T4: 57±10 (5.8±1.0, 42±7)**

**T5: 69±15 (7.0±1.5, 51±11)**

**T6: 137±20 (14±2, 101±14)**

2. AT MODEL

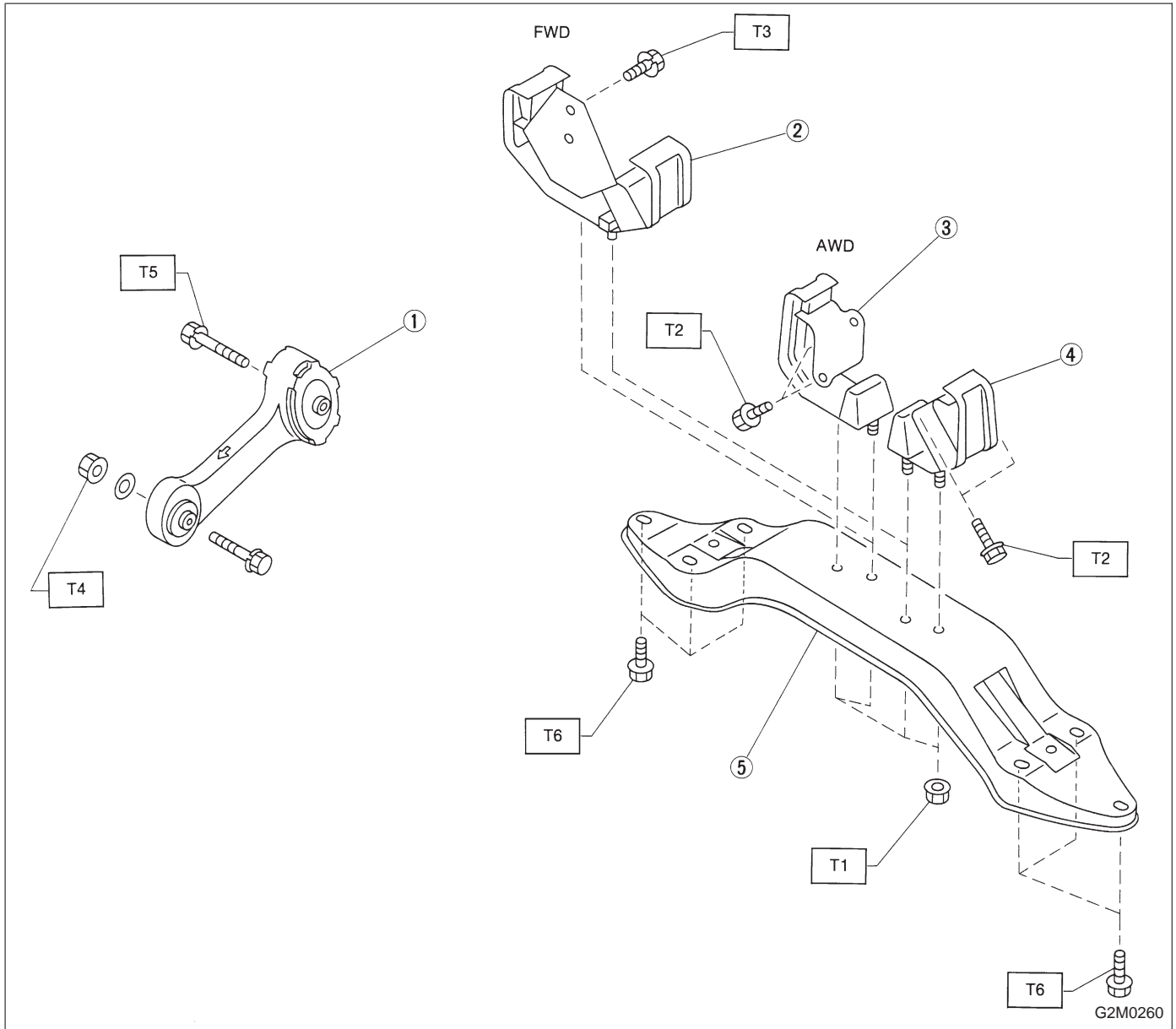

- ① Pitching stopper
- ② Rear cushion rubber (FWD)
- ③ Rear cushion rubber RH (AWD)
- ④ Rear cushion rubber LH (AWD)
- ⑤ Crossmember

**Tightening torque: N·m (kg·m, ft·lb)**

**T1: 18±5 (1.8±0.5, 13.0±3.6)**

**T2: 25±7 (2.5±0.7, 18.1±5.1)**

**T3: 26±7 (2.7±0.7, 19.5±5.1)**

**T4: 49±5 (5.0±0.5, 36.2±3.6)**

**T5: 57±10 (5.8±1.0, 42±7)**

**T6: 69±15 (7.0±1.5, 51±11)**

## 1. General Precaution

- 1) Remove or install engine and transmission in an area where chain hoists, lifting devices, etc. are available for ready use.
- 2) Be sure not to damage coated surfaces of body panels with tools or stain seats and windows with coolant or oil. Place a cover over fenders, as required, for protection.
- 3) Prior to starting work, prepare the following:  
Service tools, clean cloth, containers to catch coolant and oil, wire ropes, chain hoist, transmission jacks, etc.
- 4) Lift-up or lower the vehicle when necessary. Make sure to support the correct positions. (Refer to Chapter 1-3 "General Information".)

## 2. Engine

### A: REMOVAL

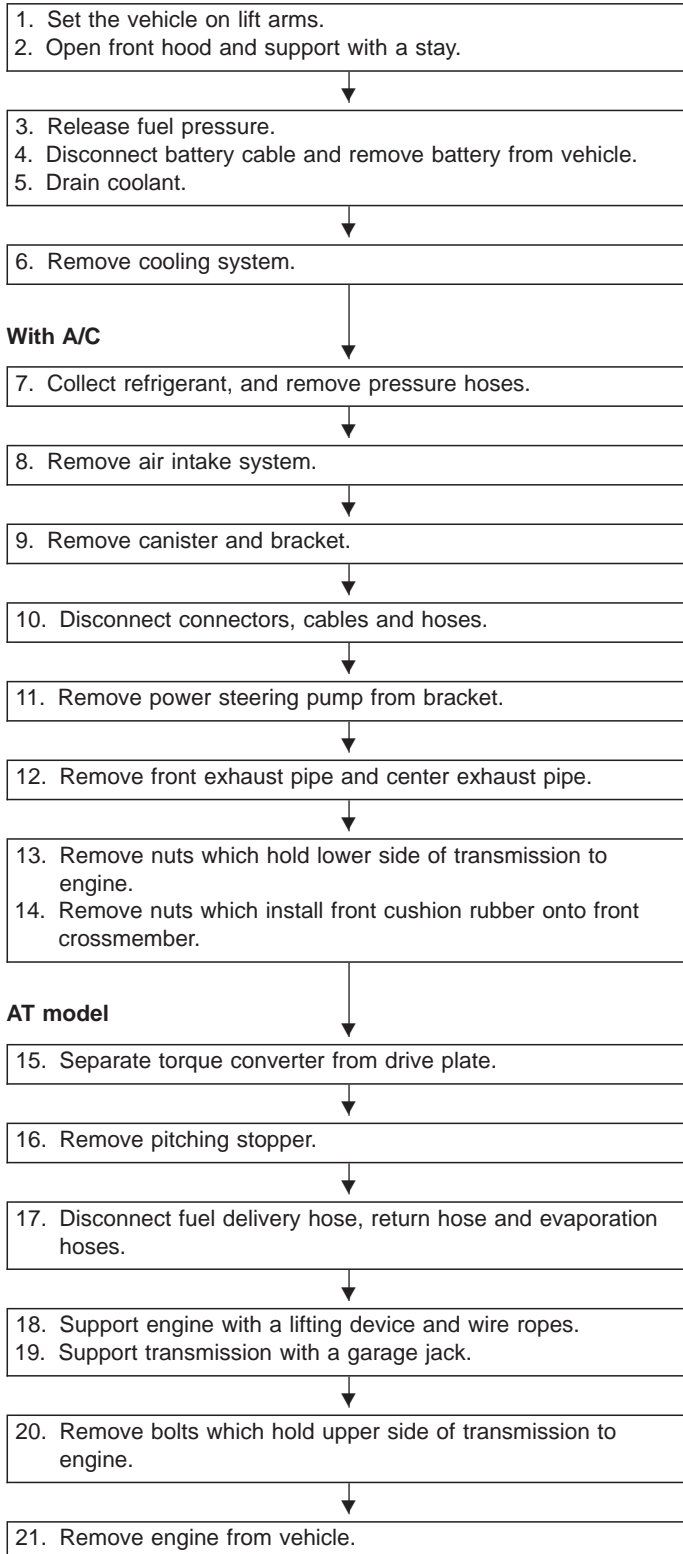

- 1) Set the vehicle on lift arms.
- 2) Open front hood fully and support with stay.

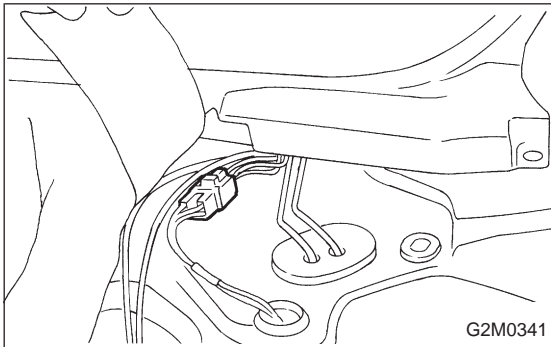

- 3) Release fuel pressure.
  - (1) Disconnect fuel tank connector.
  - (2) Start the engine, and run until it stalls.
  - (3) After the engine stalls, crank it for five seconds more.
  - (4) Turn ignition switch to "OFF".

<Ref. to 2-8 [W1A0].>

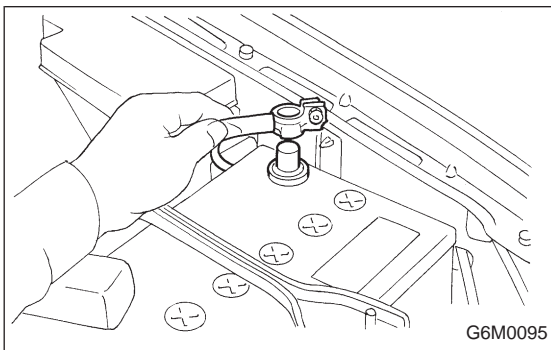

- 4) Disconnect battery cables and remove battery from vehicle.

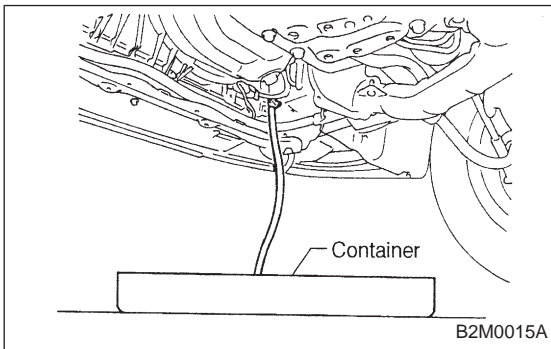

- 5) Drain coolant.
 

Set container under the vehicle, and remove drain cock from radiator.

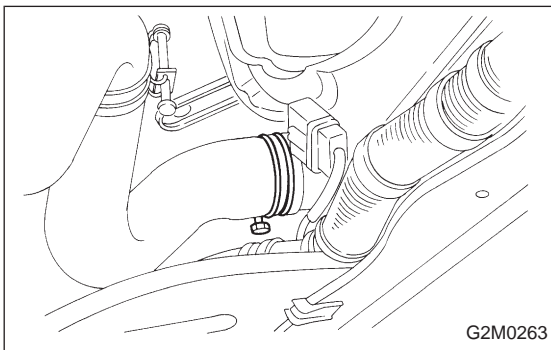

- 6) Remove cooling system.
  - (1) Disconnect radiator fan motor connector.
  - (2) Disconnect radiator outlet hose from thermostat cover.

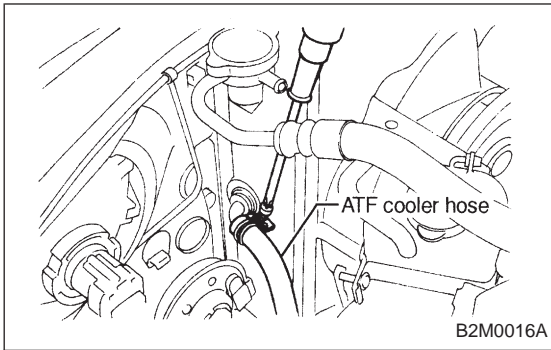

(3) Disconnect ATF cooler hoses from pipes. (AT model)

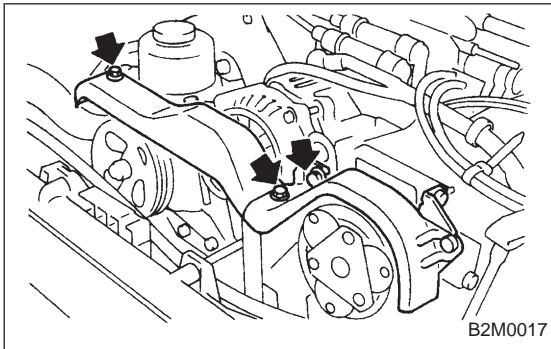

(4) Remove V-belt cover.

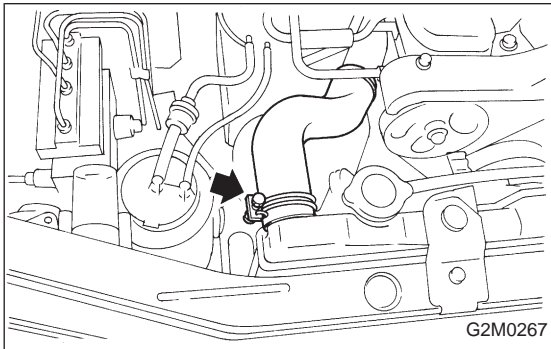

(5) Disconnect radiator inlet hose from radiator.

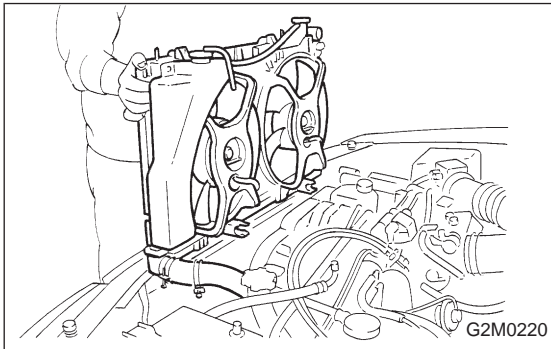

(6) Remove radiator upper bracket, and remove radiator assembly from vehicle.

7) Collect refrigerant, and remove pressure hoses. (With A/C)

- (1) Place and connect the attachment hose to the refrigerant recycle system.
- (2) Collect refrigerant from A/C system.

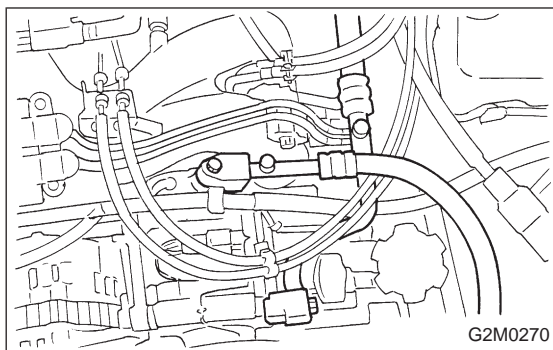

(3) Disconnect A/C pressure hoses from A/C compressor.

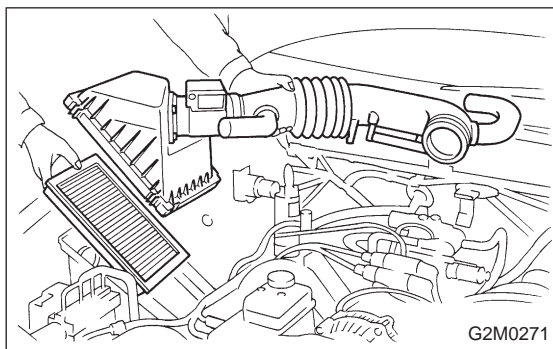

- 8) Remove air intake system.
- (1) Disconnect connector from mass air flow sensor.
  - (2) Remove air intake duct with air cleaner upper cover, and remove air cleaner element.

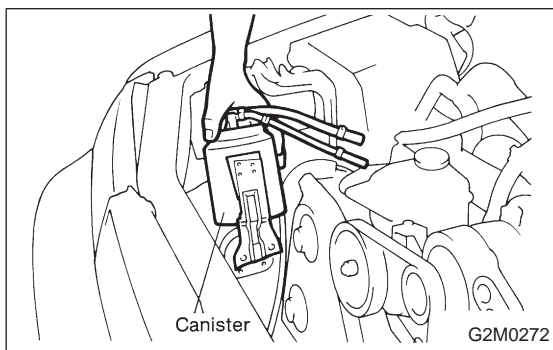

9) Remove canister and bracket.

10) Disconnect connectors, cables and hoses.

(1) Disconnect the following connectors.

- ① Front oxygen sensor connector
- ② Engine harness connectors
- ③ Engine ground terminal
- ④ Alternator connector and terminal
- ⑤ A/C compressor connectors (With A/C)

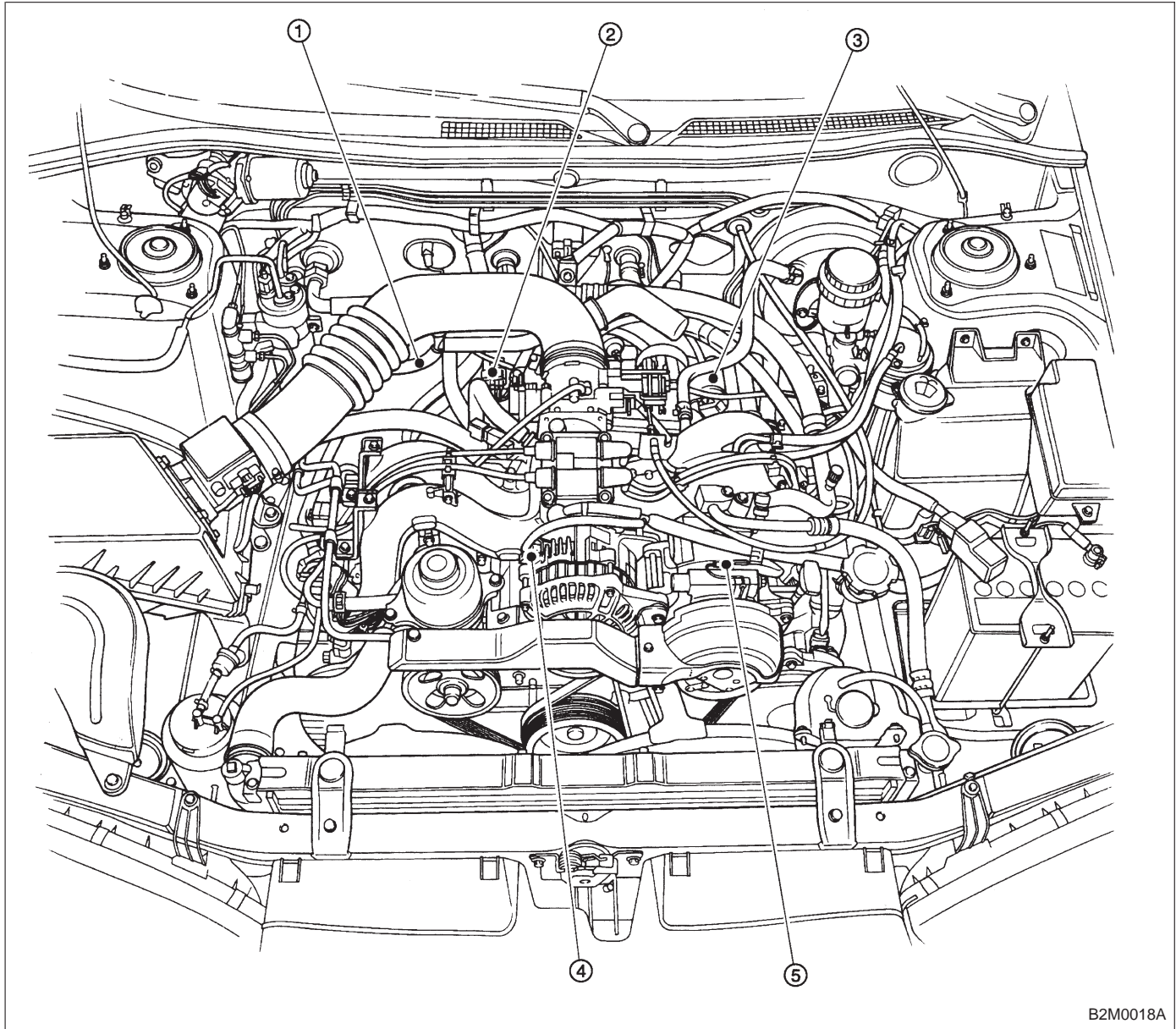

B2M0018A



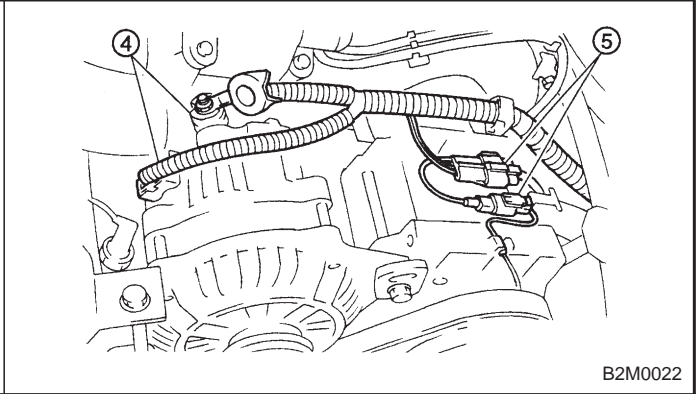
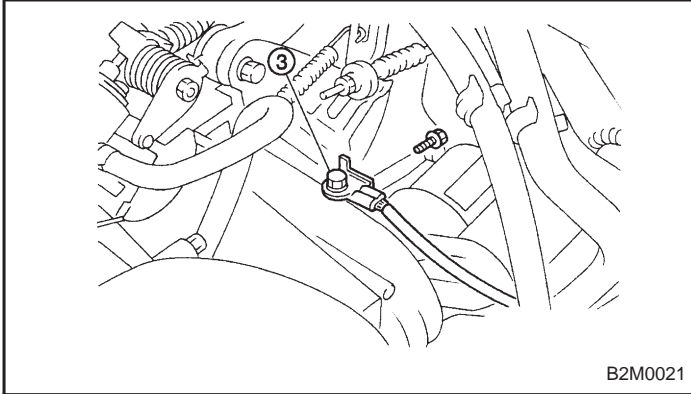
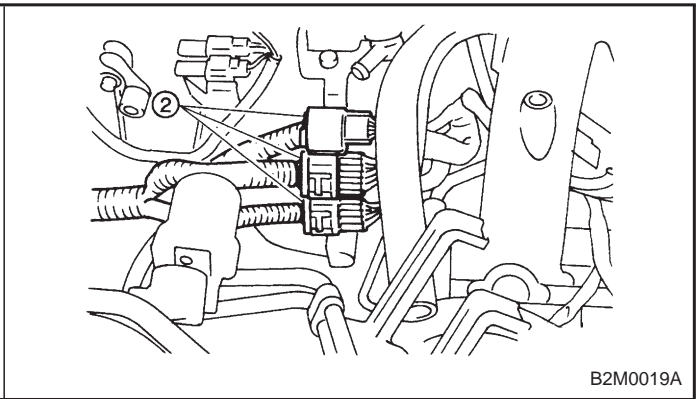
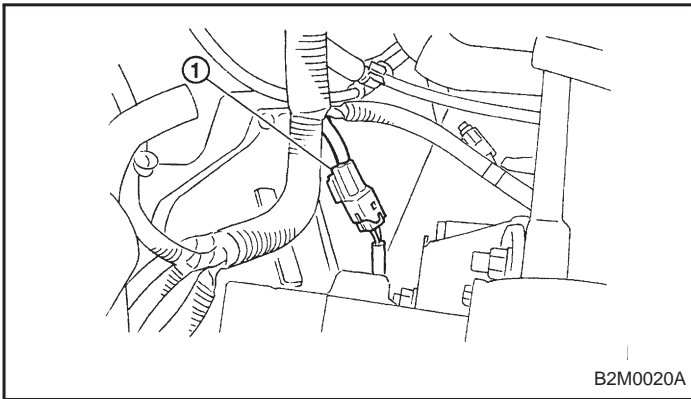

(2) Disconnect the following cables.

- ① Accelerator cable
- ② Cruise control cable (With cruise control)
- ③ Clutch release spring (MT model)
- ④ Clutch cable (MT model)

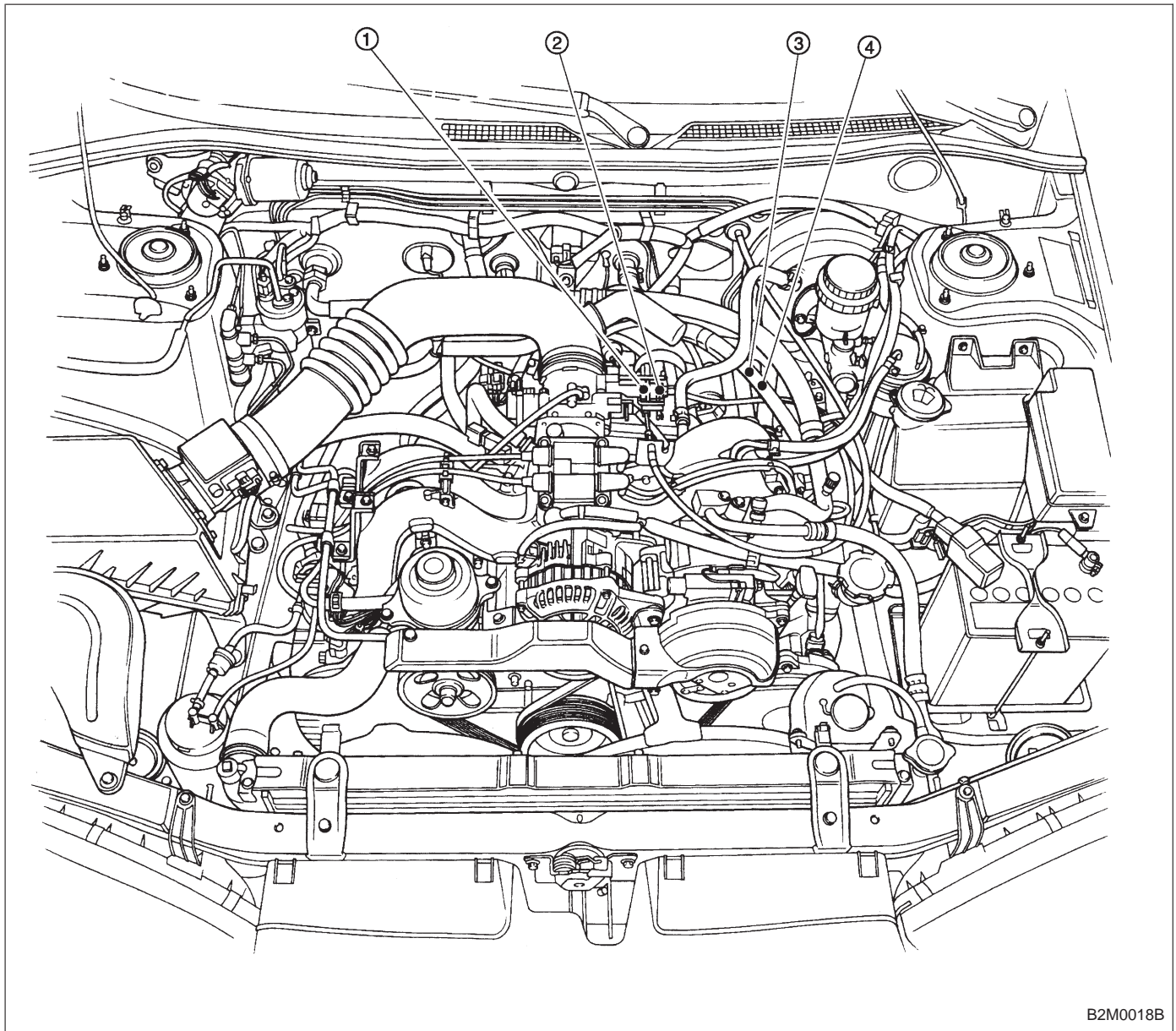

B2M0018B

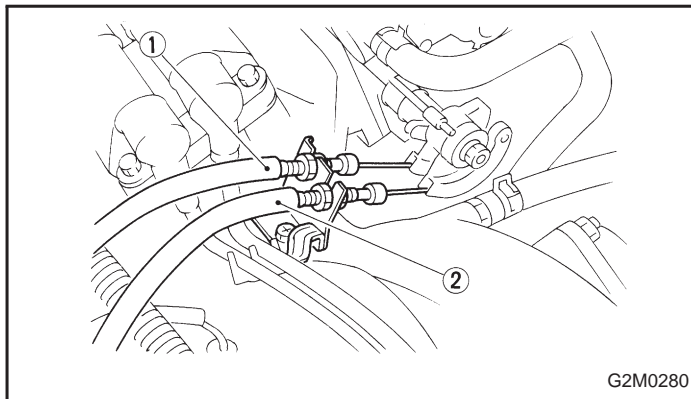

G2M0280

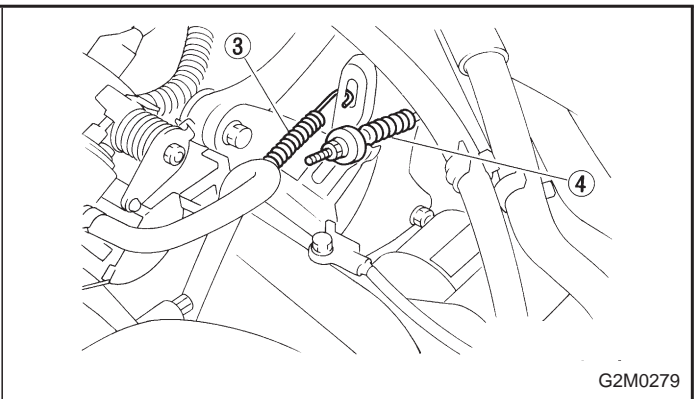

G2M0279

(3) Disconnect the following hoses.

- ① Brake booster vacuum hose
- ② Heater inlet and outlet hoses

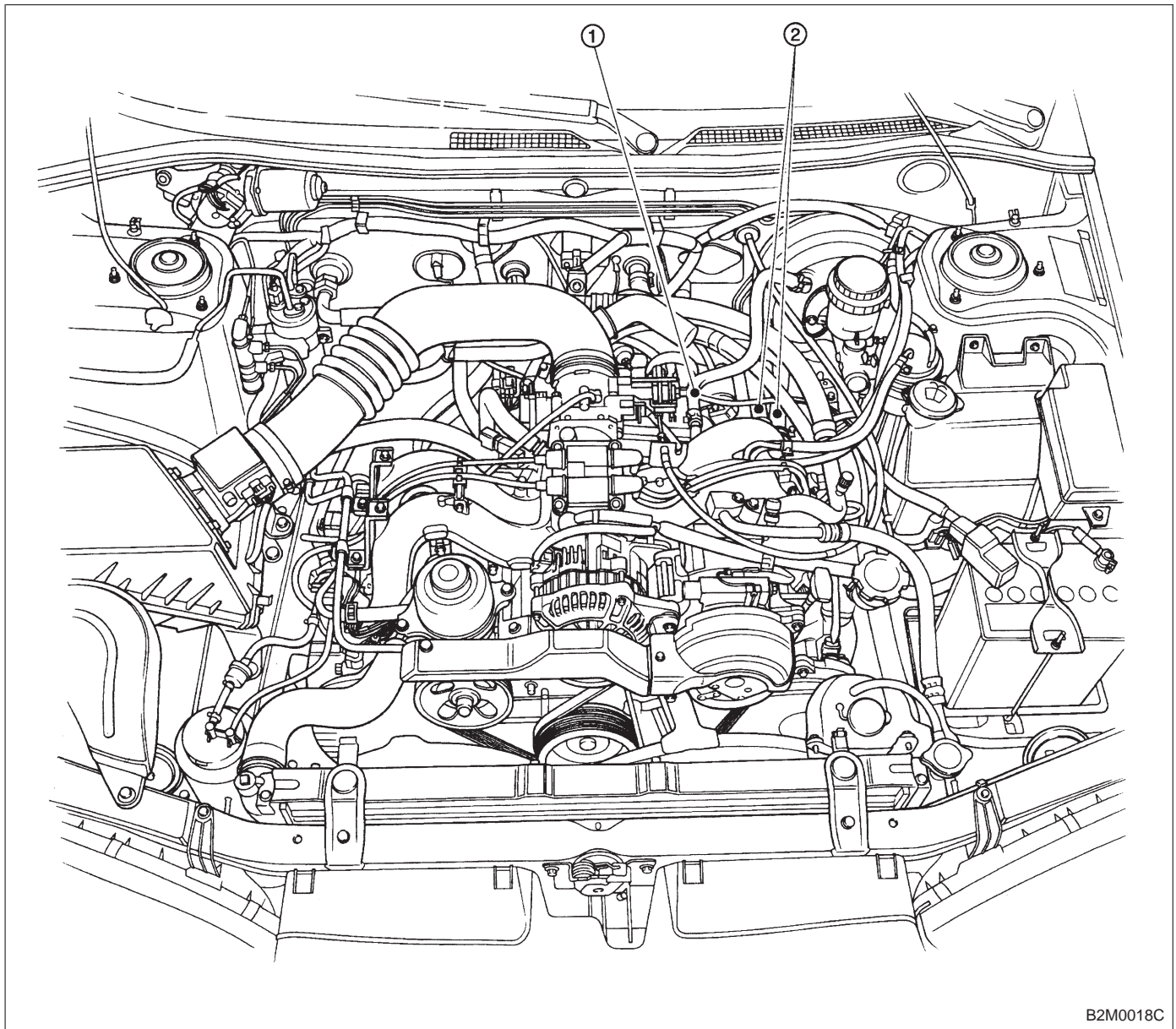

B2M0018C

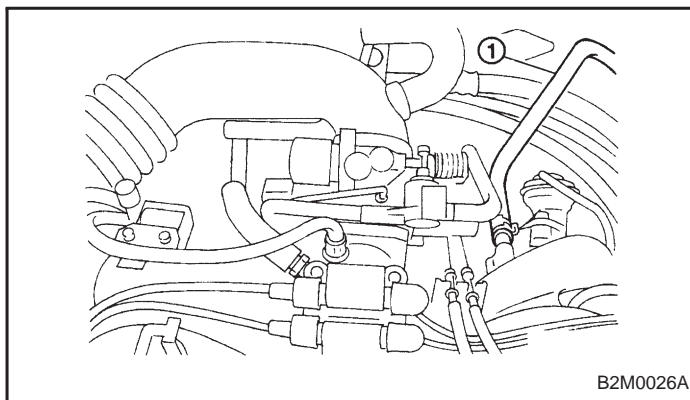

B2M0026A

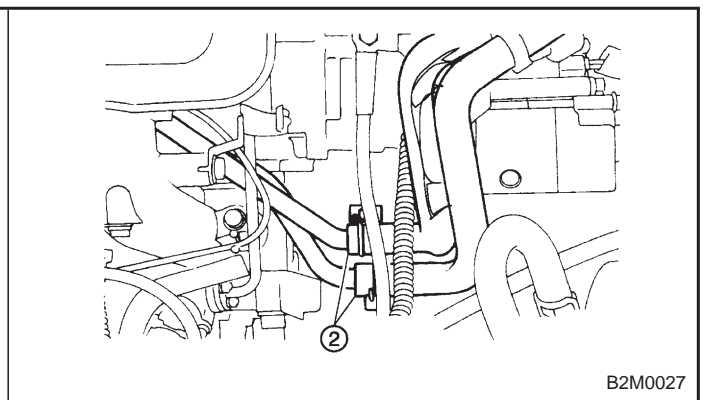

B2M0027

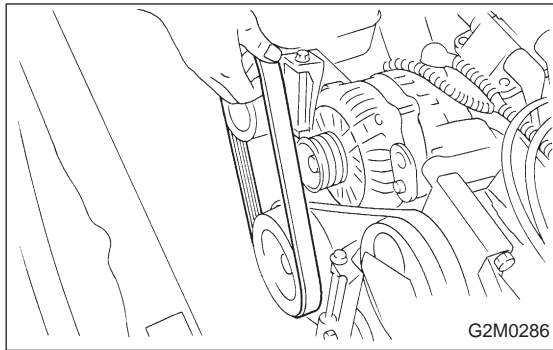

- 11) Remove power steering pump from bracket.
  - (1) Loosen lock bolt and slider bolt, and remove front side V-belt.

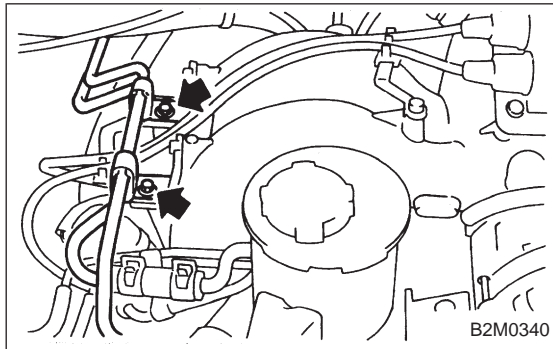

- (2) Remove pipe with bracket from intake manifold.

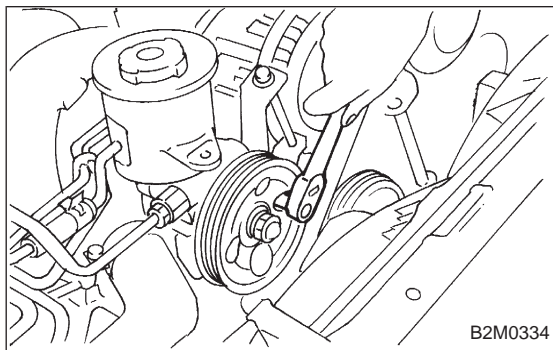

- (3) Remove bolts which install power steering pump from bracket.

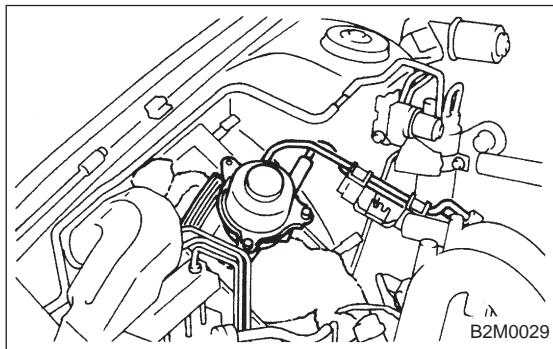

- (4) Place power steering pump on the right side wheel apron.

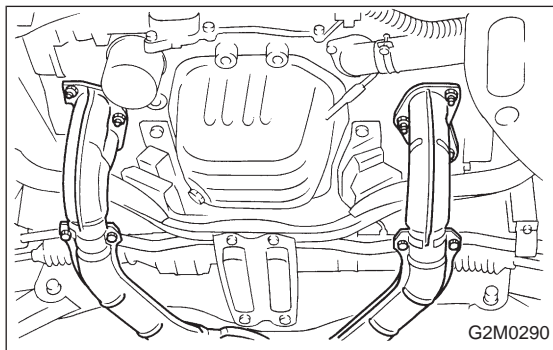

- 12) Remove front exhaust pipe and center exhaust pipe.
  - (1) Lift-up the vehicle.
  - (2) Remove nuts which install front exhaust pipe onto engine.

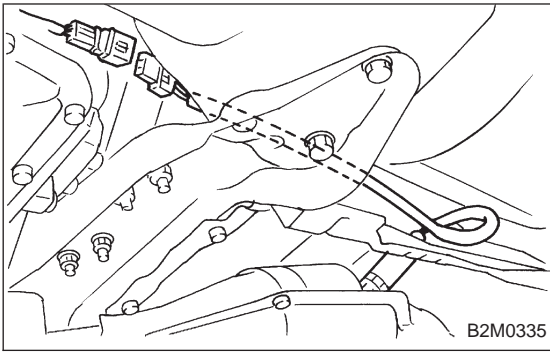

(3) Disconnect connector from rear oxygen sensor.

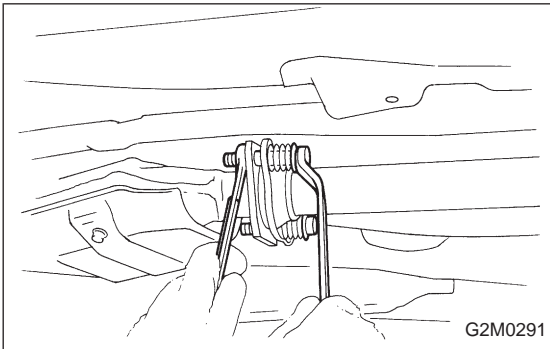

(4) Separate center exhaust pipe from rear exhaust pipe.

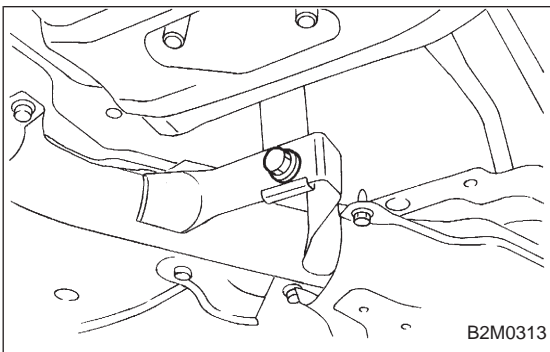

(5) Remove bolt which installs center exhaust pipe on hunger bracket.  
(6) Take off front and center exhaust pipes.

**CAUTION:**  
Exhaust pipe will drop when all bolts are removed. So, hold it when removing the last bolt.

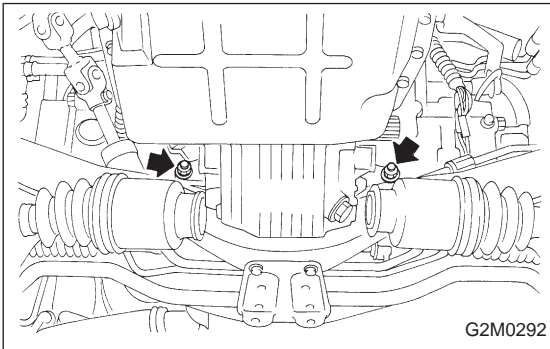

13) Remove nuts which hold lower side of transmission to engine.

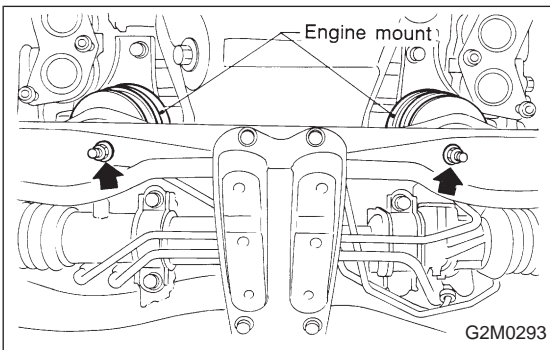

14) Remove nuts which install front cushion rubber onto front crossmember.

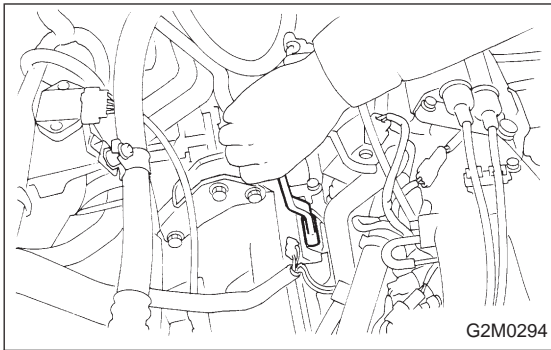

- 15) Separate torque converter from drive plate. (AT model)
- (1) Lower the vehicle.
  - (2) Remove service hole plug.
  - (3) Remove bolts which hold torque converter to drive plate.
  - (4) Remove other bolts while rotating the engine using ST.

ST 499977000 CRANK PULLEY WRENCH

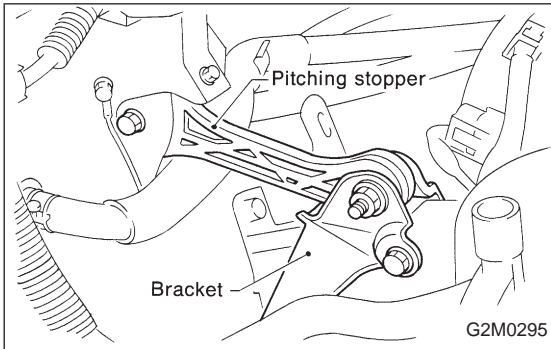

- 16) Remove pitching stopper.

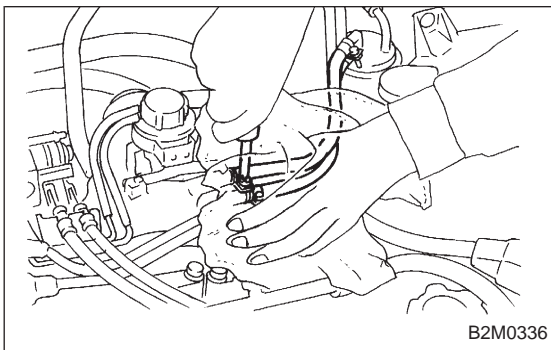

- 17) Disconnect fuel delivery hose, return hose and evaporation hose.

**CAUTION:**

- Disconnect hose with its end wrapped with cloth to prevent fuel from splashing.
- Catch fuel from hose into container.

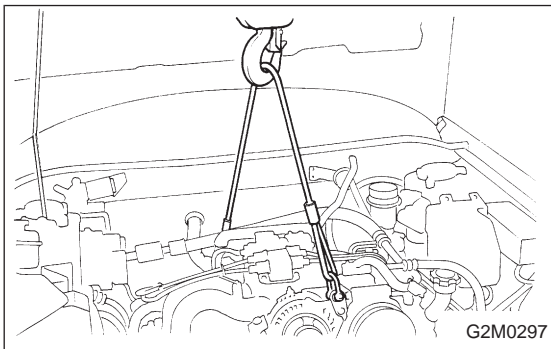

- 18) Support engine with a lifting device and wire ropes.

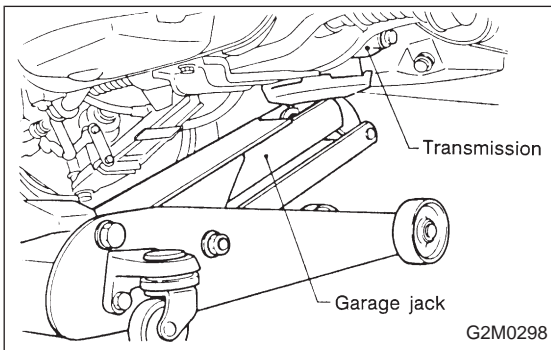

- 19) Support transmission with a garage jack.

**CAUTION:**

**Before moving engine away from transmission, check to be sure no work has been overlooked. Doing this is very important in order to facilitate re-installation and because transmission lowers under its own weight.**

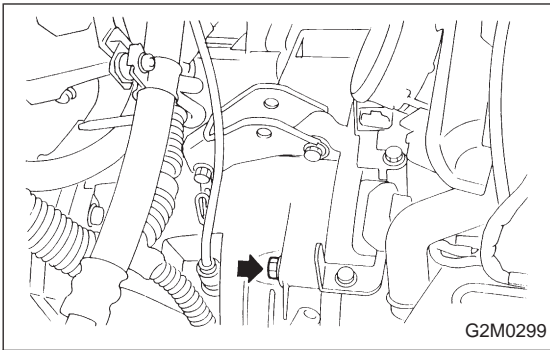

20) Remove bolts which hold upper side of transmission to engine.

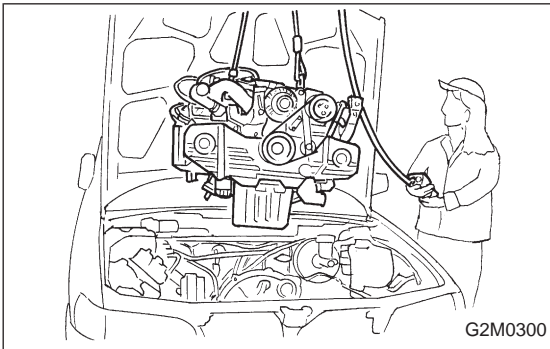

21) Remove engine from vehicle.

- (1) Slightly raise engine.
- (2) Raise transmission with garage jack.
- (3) Move engine horizontally until mainshaft is withdrawn from clutch cover.
- (4) Slowly move engine away from engine compartment.

**CAUTION:**

**Be careful not to damage adjacent parts or body panels with crank pulley, oil pressure gauge, etc.**

**B: INSTALLATION**

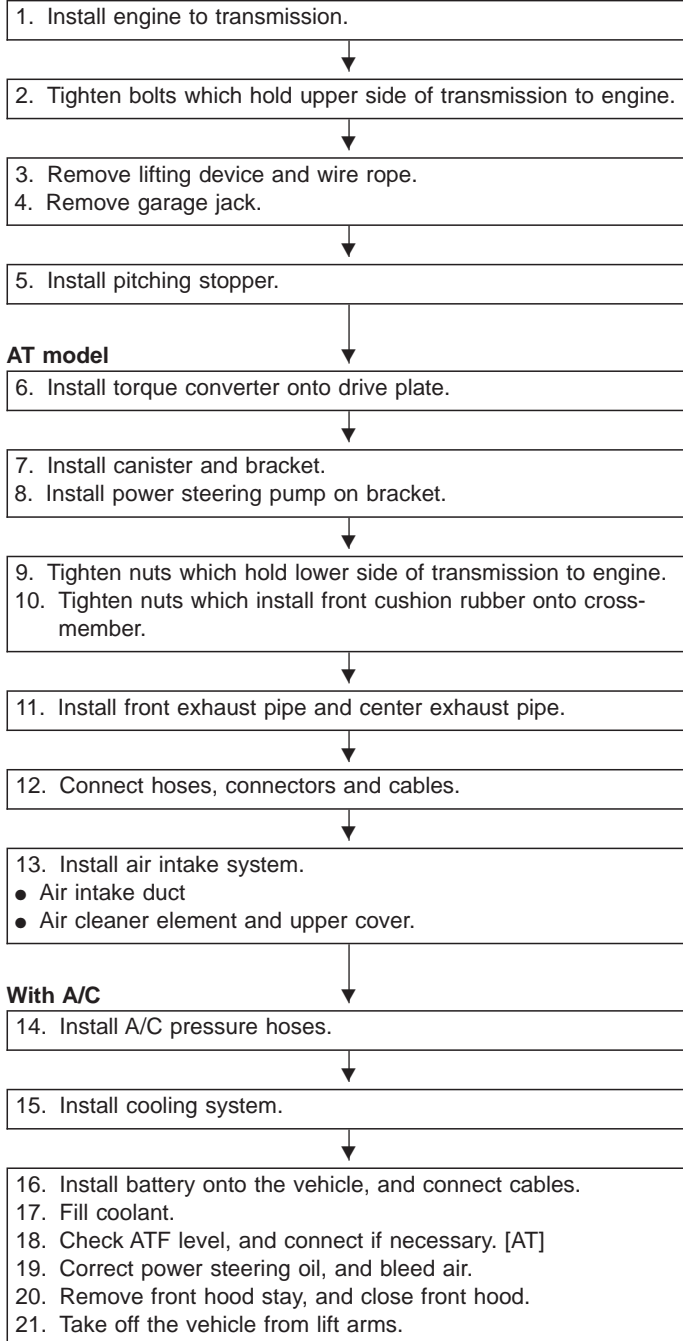



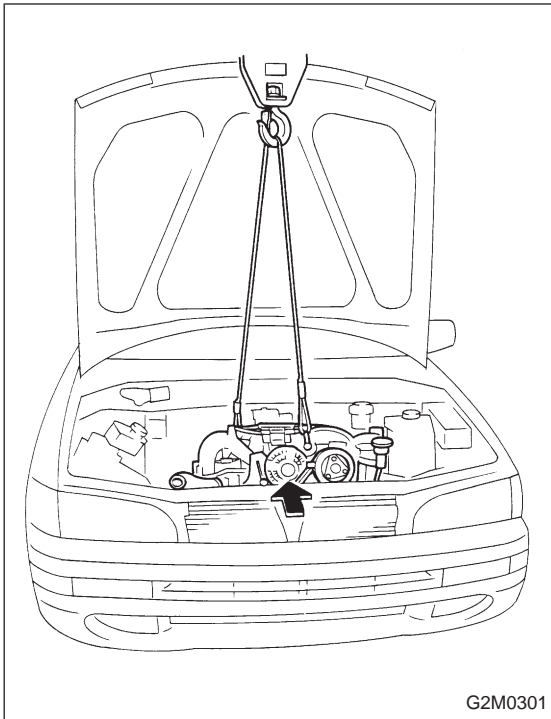

- 1) Install engine onto transmission.
  - (1) Position engine in engine compartment and align it with transmission.

**CAUTION:**

Be careful not to damage adjacent parts or body panels with crank pulley, oil pressure gauge, etc.

- (2) Apply a small amount of grease to spline of mainshaft.

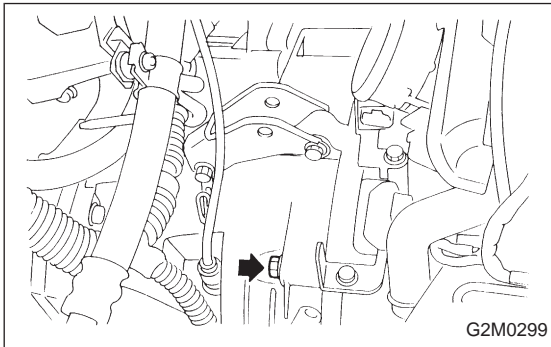

- 2) Tighten bolts which hold upper side of transmission to engine.

**Tightening torque:**

**$50 \pm 4$  N-m ( $5.1 \pm 0.4$  kg-m,  $36.9 \pm 2.9$  ft-lb)**

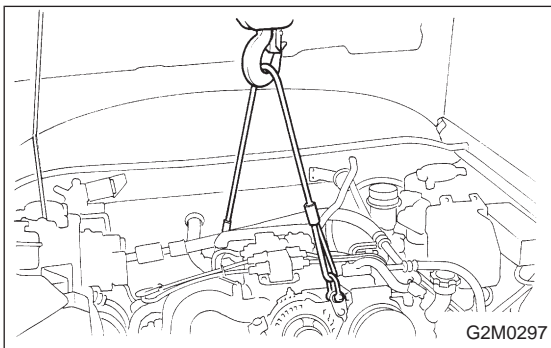

- 3) Remove lifting device and wire ropes.
- 4) Remove garage jack.

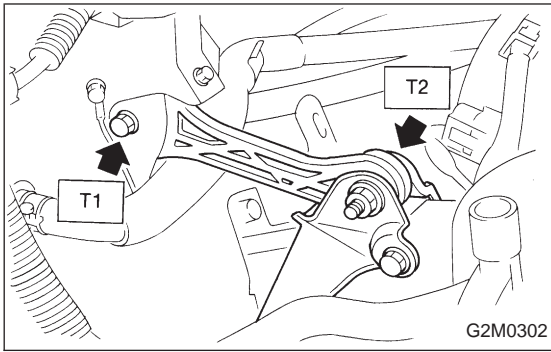

5) Install pitching stopper.

**Tightening torque:**

**T1:  $49\pm 5$  N·m ( $5.0\pm 0.5$  kg·m,  $36.2\pm 3.6$  ft·lb)**

**T2:  $57\pm 10$  N·m ( $5.8\pm 1.0$  kg·m,  $42\pm 7$  ft·lb)**

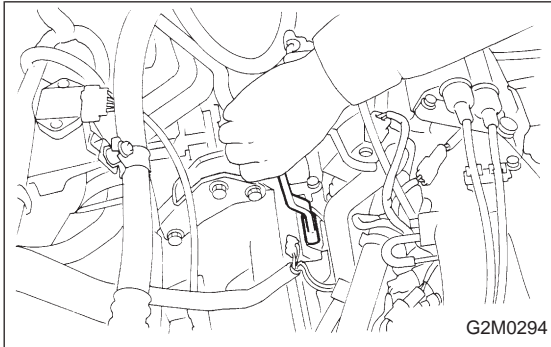

6) Install torque converter onto drive plate. (AT model)

(1) Tighten bolts which hold torque converter to drive plate.

(2) Tighten other bolts while rotating the engine by using ST.

ST 499977000 CRANK PULLEY WRENCH

**CAUTION:**

**Be careful not to drop bolts into torque converter housing.**

**Tightening torque:**

**$25\pm 2$  N·m ( $2.5\pm 0.2$  kg·m,  $18.1\pm 1.4$  ft·lb)**

(3) Clog plug onto service hole.

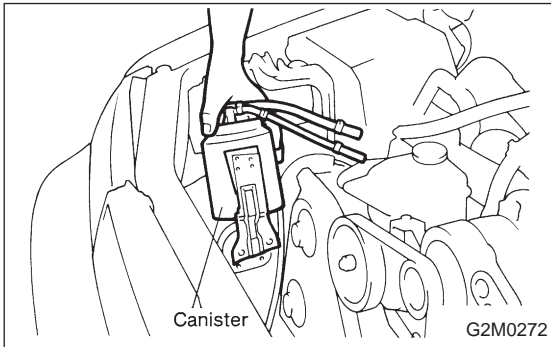

7) Install canister and bracket.

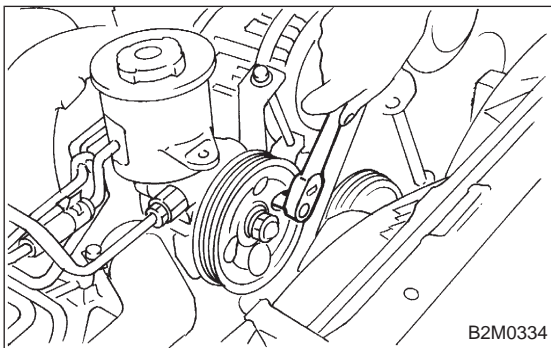

8) Install power steering pump on bracket.

(1) Install power steering pump on bracket, and tighten bolts.

**Tightening torque:**

**$39\pm 10$  N·m ( $4.0\pm 1.0$  kg·m,  $29\pm 7$  ft·lb)**

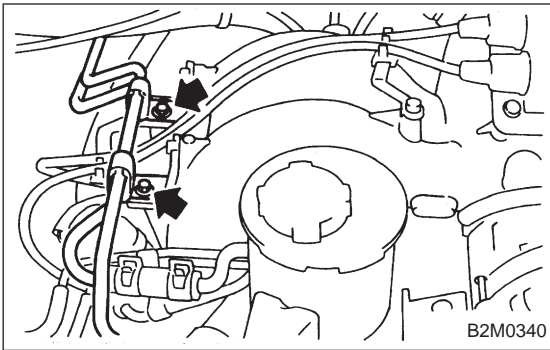

(2) Install power steering pipe bracket on right side intake manifold, and install spark plug codes.

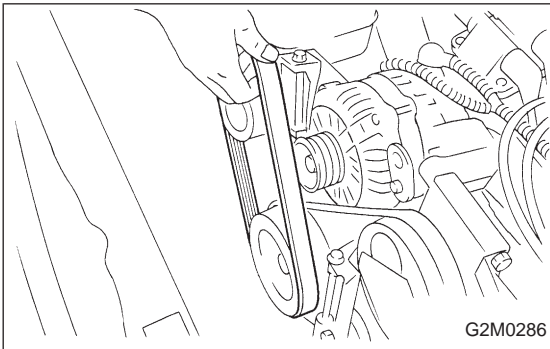

(3) Install front side V-belt, and adjust it.  
<Ref. to 1-5 [01A0].>

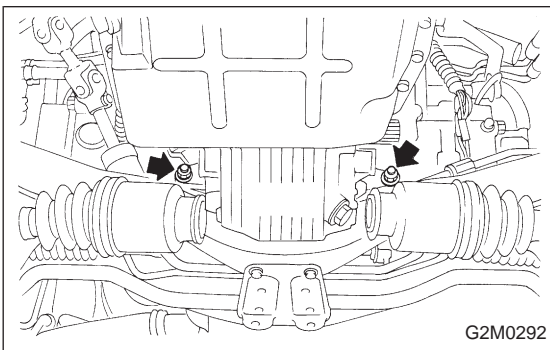

9) Tighten nuts which hold lower side of transmission to engine.

**Tightening torque:**

**$50 \pm 4 \text{ N}\cdot\text{m}$  ( $5.1 \pm 0.4 \text{ kg}\cdot\text{m}$ ,  $36.9 \pm 2.9 \text{ ft}\cdot\text{lb}$ )**

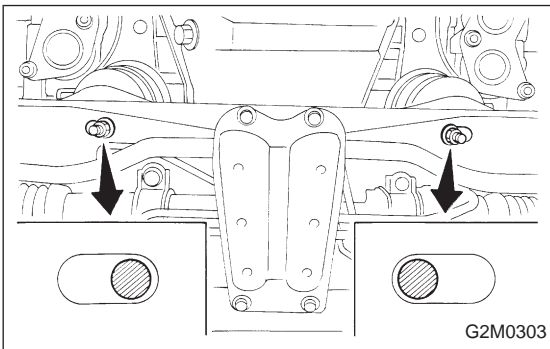

10) Tighten nuts which install front cushion rubber onto crossmember.

**Tightening torque:**

**$69 \pm 15 \text{ N}\cdot\text{m}$  ( $7.0 \pm 1.5 \text{ kg}\cdot\text{m}$ ,  $51 \pm 11 \text{ ft}\cdot\text{lb}$ )**

**CAUTION:**

**Be sure to tighten front cushion rubber mounting bolts in the innermost elliptical hole in the front crossmember.**

- 11) Install front exhaust pipe and center exhaust pipe.
- 12) Connect hoses, connectors and cables.
  - (1) Connect the following hoses.
    - Fuel delivery hose, return hose and evaporation hose
    - Heater inlet and outlet hoses
    - Brake booster vacuum hose
  - (2) Connect the following connectors.
    - Engine ground terminal
    - Engine harness connectors
    - Front oxygen sensor connector
    - Rear oxygen sensor connector
    - Alternator connector and terminal
    - A/C compressor connectors (With A/C)
  - (3) Connect the following cables.
    - Accelerator cable
    - Cruise control cables (With cruise control)
    - Clutch cable
    - Clutch release spring

**CAUTION:**

**After connecting each cable, adjust them.**

- 13) Install air intake system.
  - (1) Install air cleaner element.
  - (2) Install air intake duct with air cleaner upper cover.

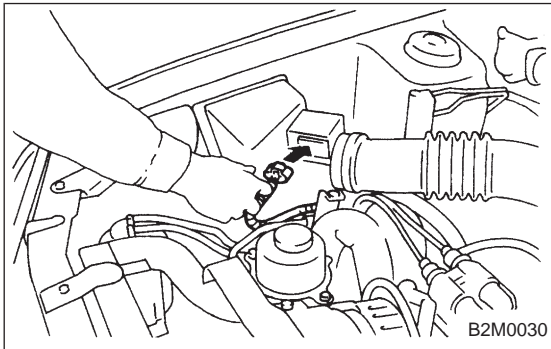
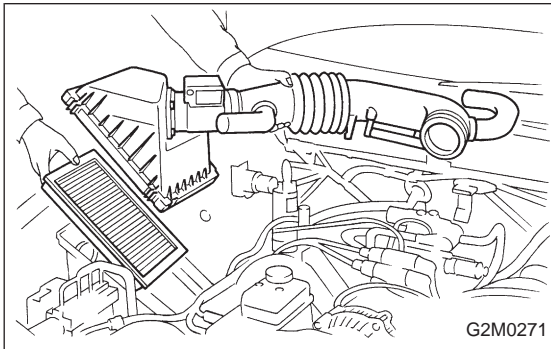

- (3) Connect connector to mass air flow sensor.

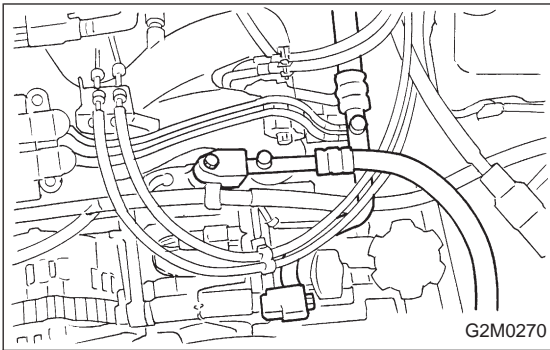

- 14) Install A/C pressure hoses. (With A/C)  
<Ref. to 4-7.>

**CAUTION:**  
Use new O-rings.

**Tightening torque:**  
 $25 \pm 7 \text{ N}\cdot\text{m}$  ( $2.5 \pm 0.7 \text{ kg}\cdot\text{m}$ ,  $18.1 \pm 5.1 \text{ ft}\cdot\text{lb}$ )

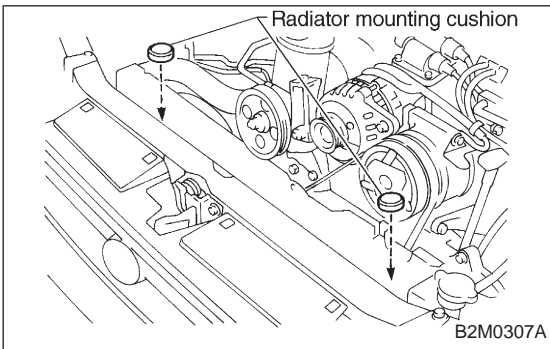

- 15) Install cooling system.

- (1) Attach radiator mounting cushions to body.

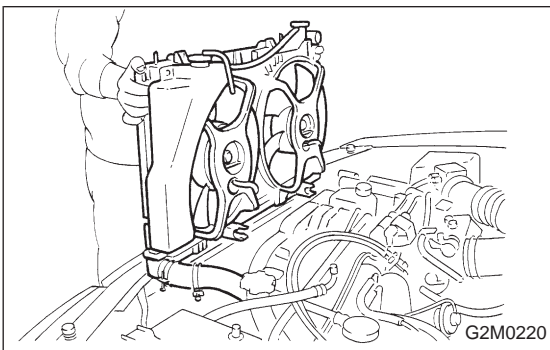

- (2) Install radiator while fitting radiator pins to cushions.

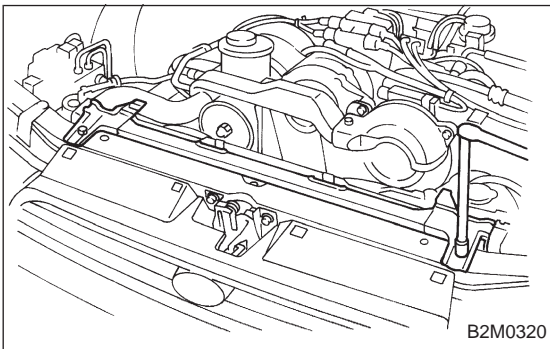

- (3) Install radiator brackets and tighten bolts.  
**Tightening torque:**  
 $13.7 \pm 1.5 \text{ N}\cdot\text{m}$  ( $1.4 \pm 0.15 \text{ kg}\cdot\text{m}$ ,  $10.1 \pm 1.1 \text{ ft}\cdot\text{lb}$ )

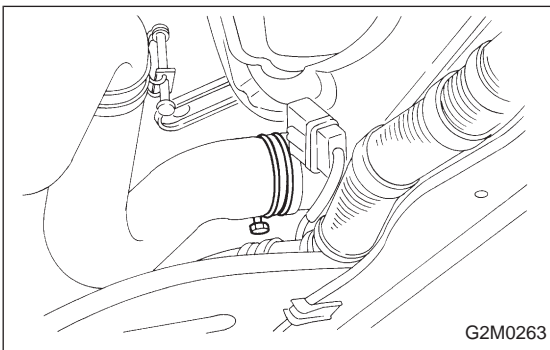

- (4) Connect radiator fan motor connector.

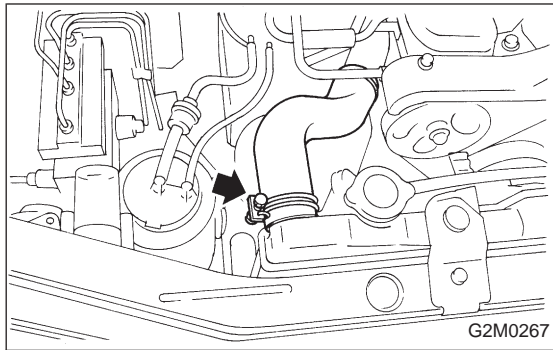

(5) Connect radiator inlet hose.

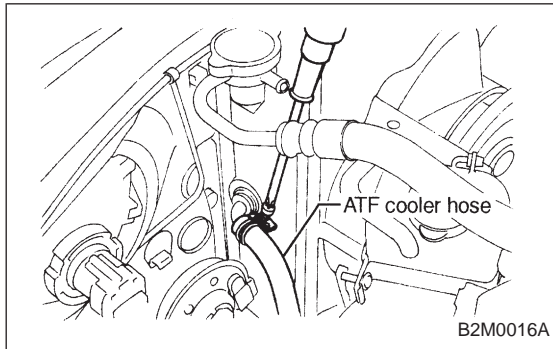

(6) Connect radiator outlet hose.  
(7) Connect ATF cooler hoses. (AT model)

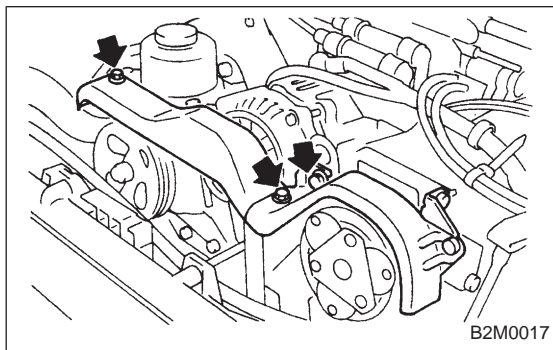

(8) Install V-belt cover.

16) Install battery in the vehicle, and connect cables.  
17) Fill coolant.

<Ref. to 2-5 [W1B0].>

18) Check ATF level and correct if necessary. (AT model)

<Ref. to 3-2 [W2A1].>

19) Charge A/C system with refrigerant.

<Ref. to 4-7 [W700].>

20) Remove front hood stay, and close front hood.

21) Take off the vehicle from lift arms.

### 3. Transmission

#### A: REMOVAL

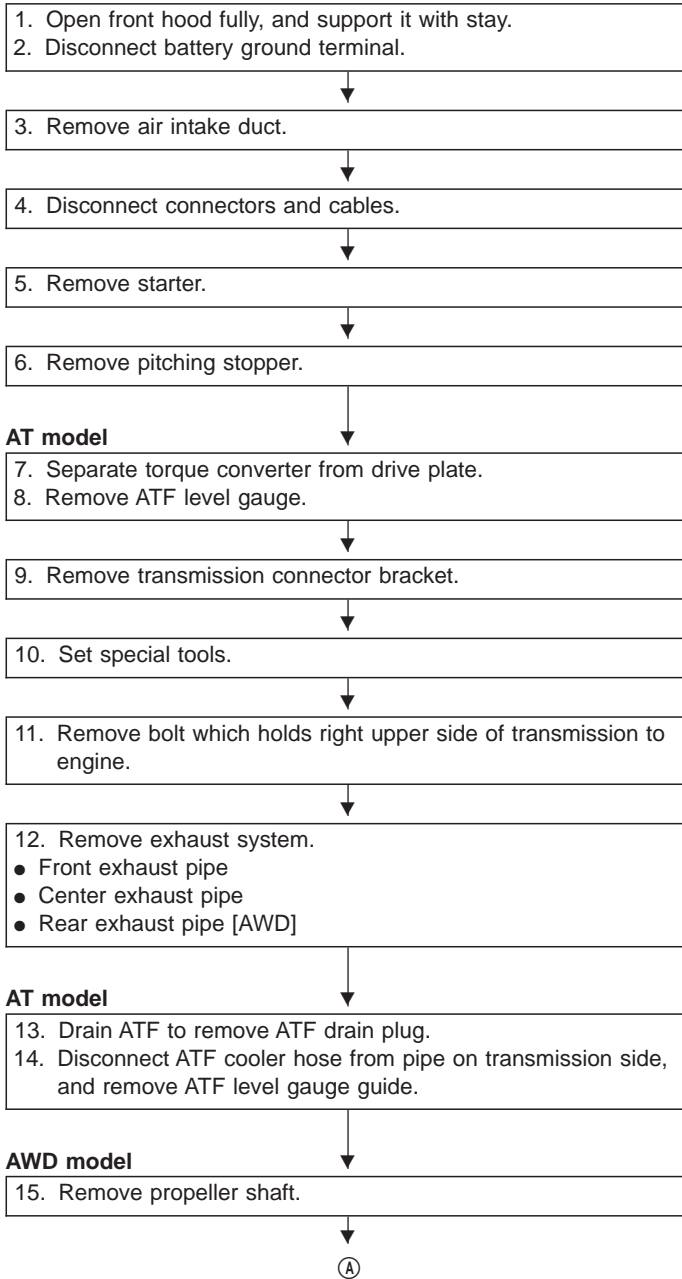

3. Transmission

---

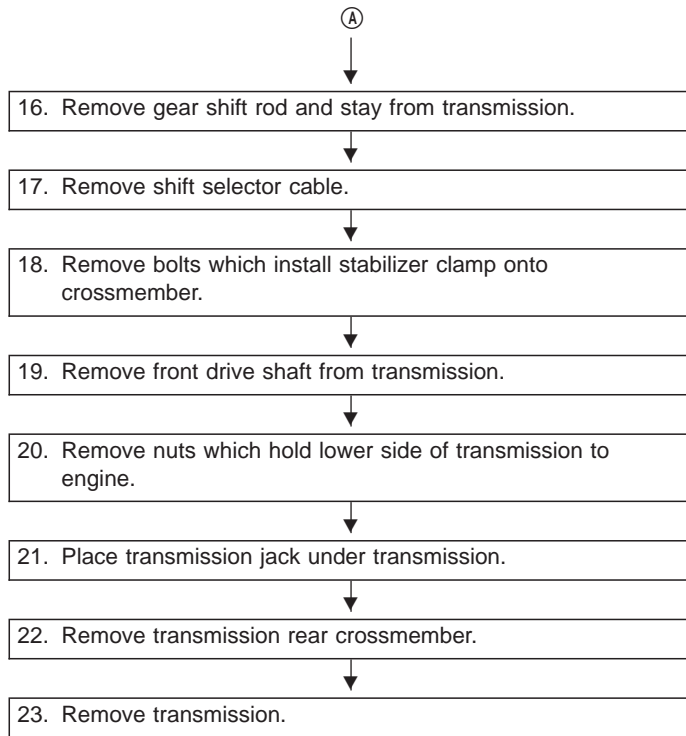



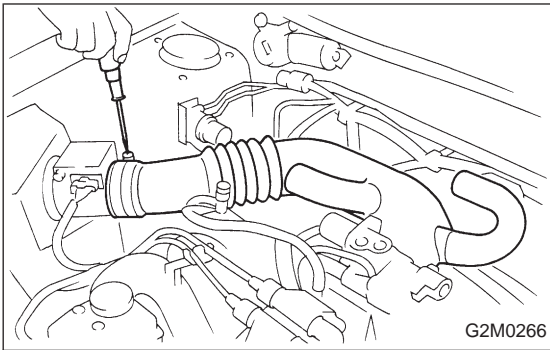

- 1) Open front hood fully, and support with stay.
- 2) Disconnect battery ground terminal.
- 3) Remove air intake duct.

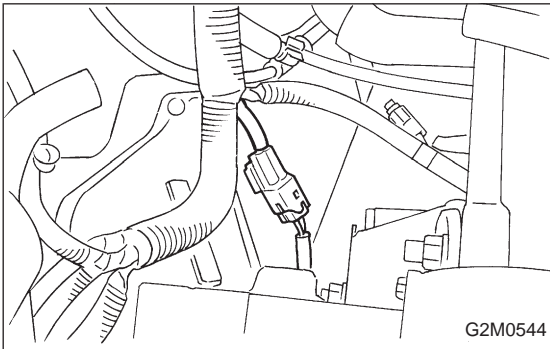

- 4) Disconnect connectors and cables.
  - (1) Disconnect the following connectors.
    - Front oxygen sensor connector

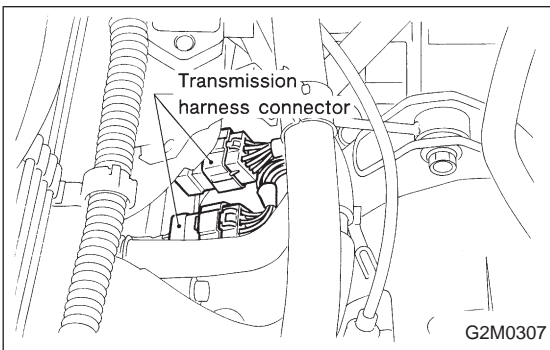

- Transmission harness connector
- Transmission ground terminal

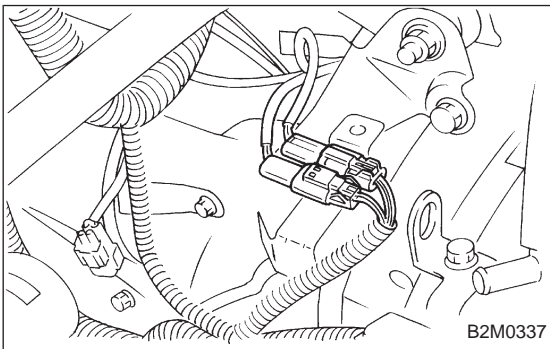

- Neutral position switch connector (MT model)
- Back-up light switch connector (MT model)

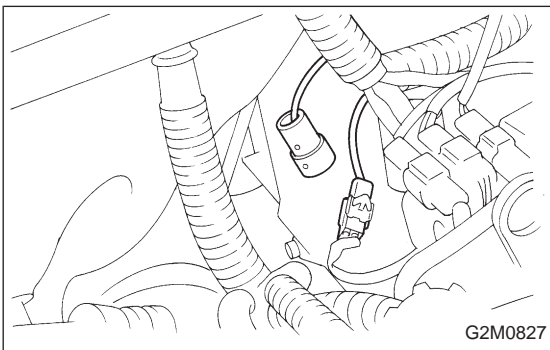

- Vehicle speed sensor 2

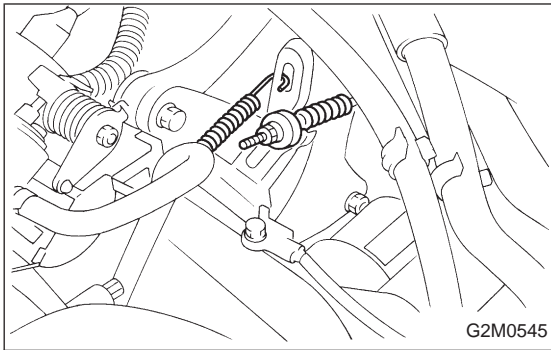

- (2) Disconnect the following cables.
- Clutch release spring (MT model)
  - Clutch cable (MT model)

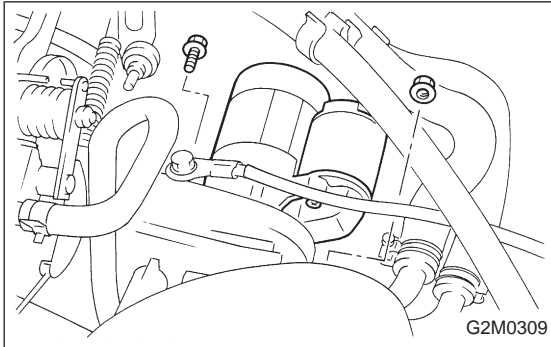

- 5) Remove starter.
- (1) Disconnect connectors and terminal from starter.
  - (2) Remove bolt which installs upper side of starter.
  - (3) Remove nut which installs lower side of starter, and remove starter from transmission.

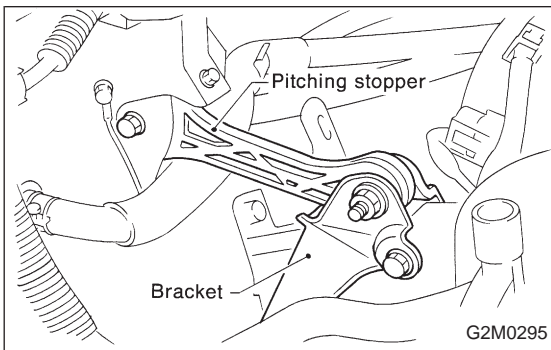

- 6) Remove pitching stopper.

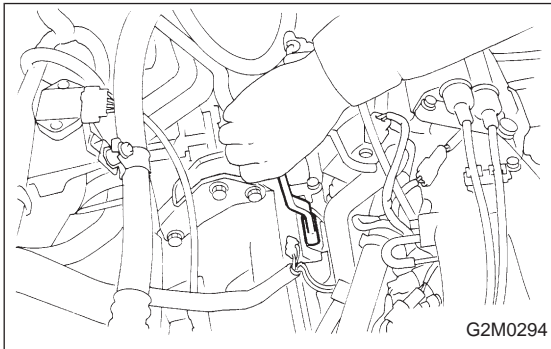

- 7) Separate torque converter from drive plate. (AT model)
- (1) Remove service hole plug.
  - (2) Remove bolts which hold torque converter to drive plate.
  - (3) While rotating the engine, remove other bolts using ST.

ST 499977000 CRANK PULLEY WRENCH

**CAUTION:**  
Be careful not to drop bolts into torque converter housing.

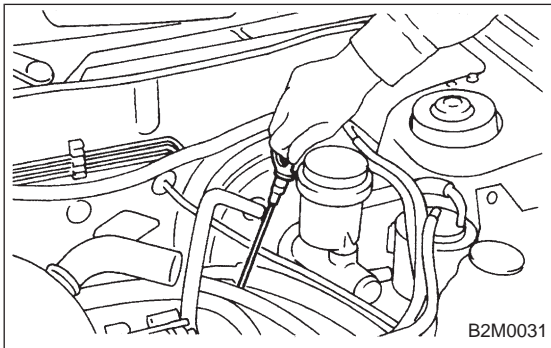

- 8) Remove ATF level gauge. (AT model)
- CAUTION:**  
Plug opening to prevent entry of foreign particles into transmission fluid.

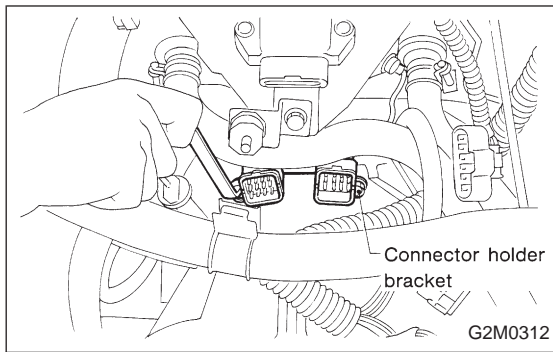

9) Remove transmission connector holder bracket.

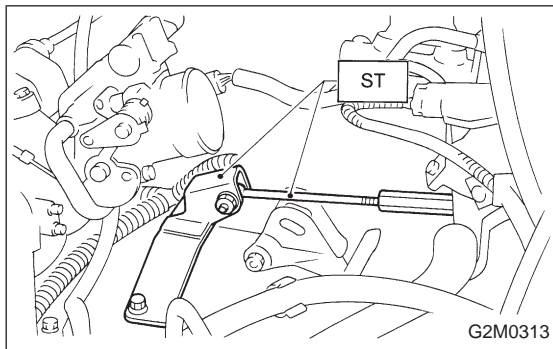

10) Set ST.

ST 41099AA020 ENGINE SUPPORT ASSY

NOTE:

Also is available Part No. 927670000.

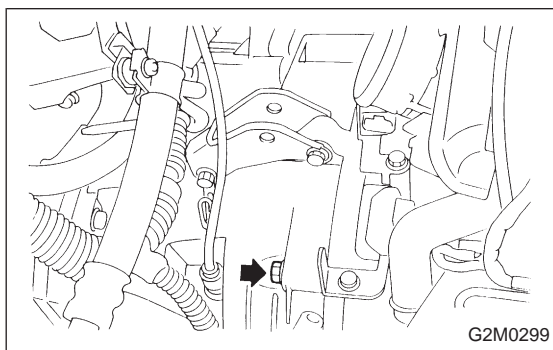

11) Remove bolt which holds right upper side of transmission to engine.

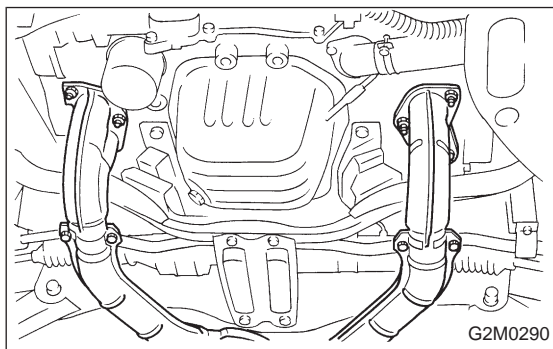

12) Remove exhaust system.

(1) Lift-up the vehicle.

(2) Remove nuts which install front exhaust pipe onto engine.

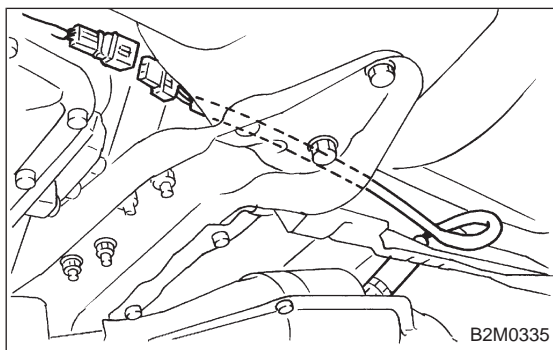

(3) Disconnect connector from rear oxygen sensor.

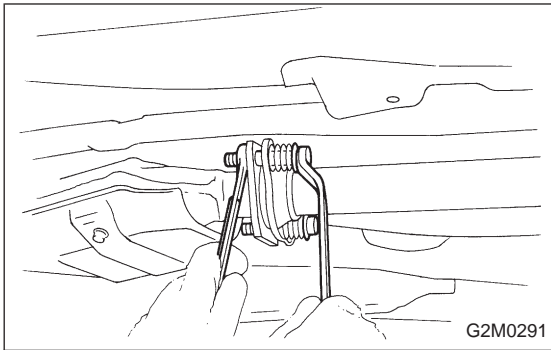

(4) Separate center exhaust pipe from rear exhaust pipe.

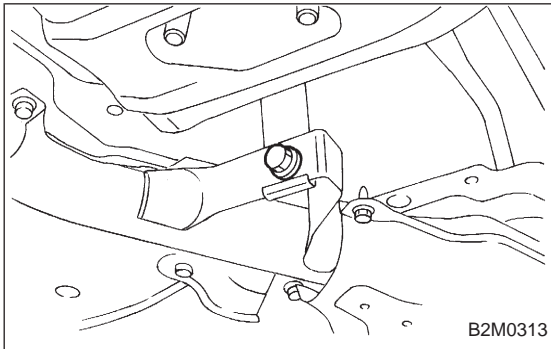

(5) Remove bolt which installs center exhaust pipe to hanger bracket.

(6) Take off front and center exhaust pipes.

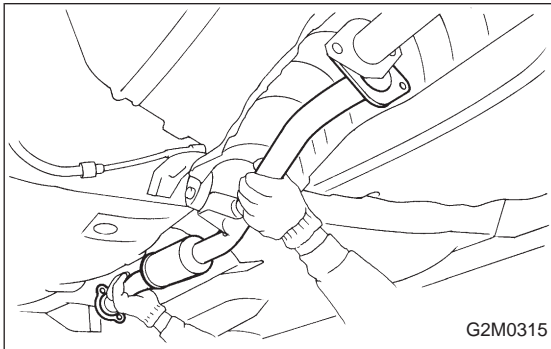

(7) Remove rear exhaust pipe. (AWD model)

**CAUTION:**

**When removing exhaust pipes, be careful each exhaust pipe does not drop out.**

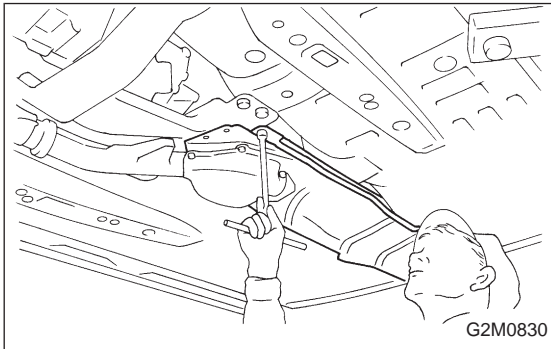

(8) Remove heat shield cover of rear exhaust pipe. (AWD model)

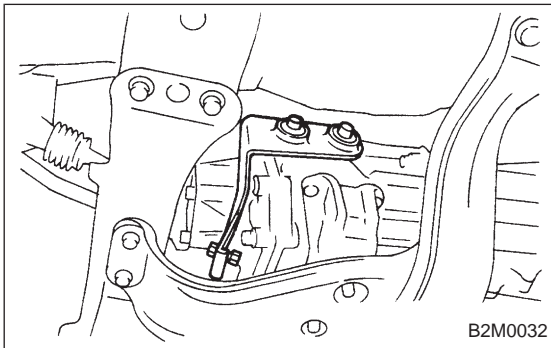

(9) Remove hanger bracket from right side of transmission. (AWD model)

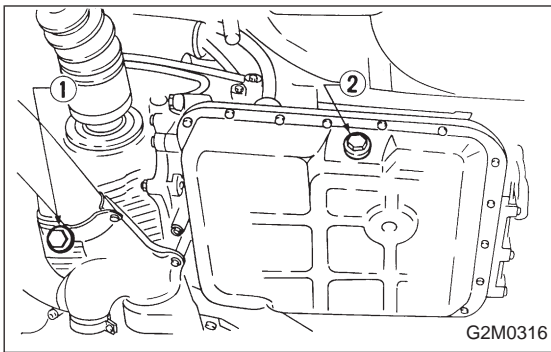

13) Drain ATF to remove ATF drain plug. (AT model)

- ① Front differential oil drain plug
- ② ATF drain plug

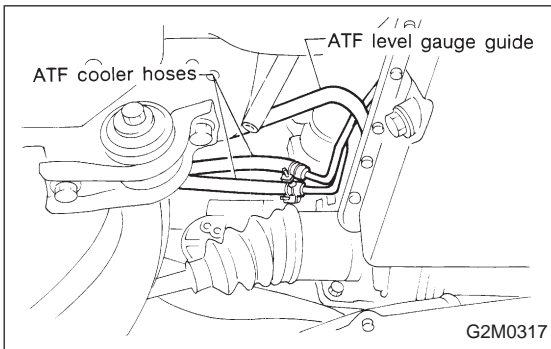

14) Disconnect ATF cooler hoses from pipes of transmission side, and remove ATF level gauge guide. (AT model)

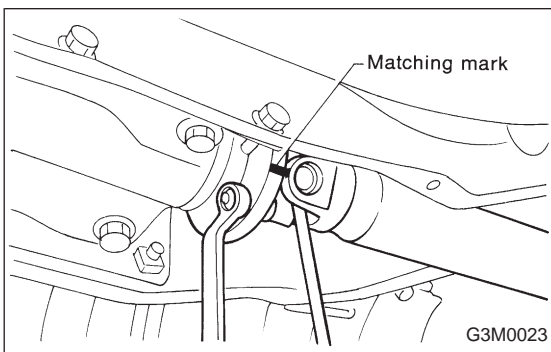

15) Remove propeller shaft. (AWD model)

- (1) Remove front cover of rear differential mount.
- (2) Separate propeller shaft from rear differential.

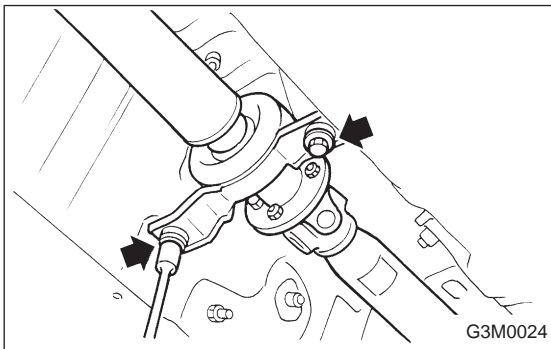

(3) Remove bolts which hold center bearing onto body.

**CAUTION:**  
Be careful not to drop propeller shaft.

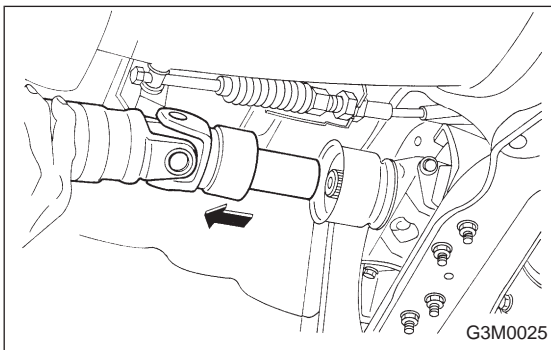

(4) Remove propeller shaft from transmission.

**CAUTION:**

- Be sure to use an empty container to catch oil flowing out when removing propeller shaft.
- Be sure not to damage oil seals and the frictional surface of sleeve yoke.
- Be sure to plug the opening in transmission after removal of propeller shaft.

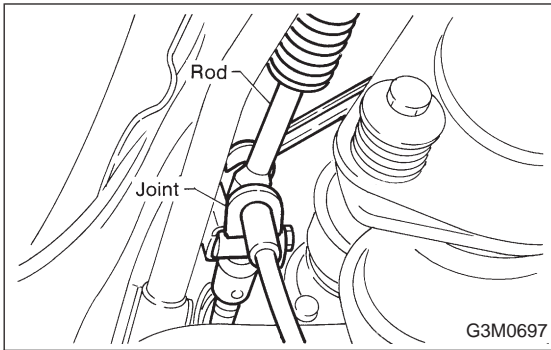

16) Remove gear shift rod and stay from transmission. (MT model)

- (1) Remove spring.
- (2) Disconnect stay from transmission.
- (3) Disconnect rod from transmission.

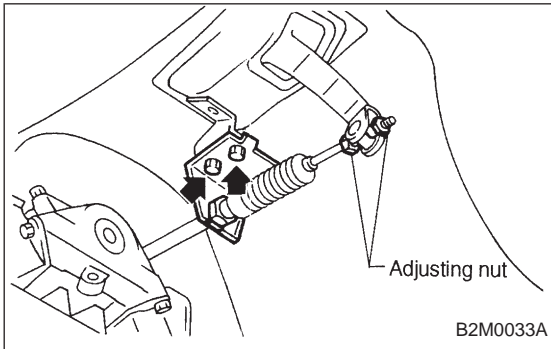

17) Remove shift selector cable. (AT model)

- (1) Disconnect shift selector cable from selector lever.
- (2) Remove cable bracket from body.

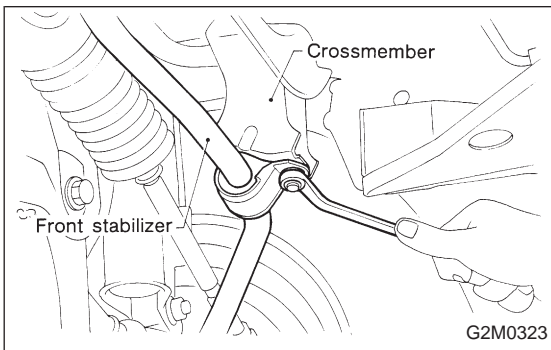

18) Remove bolts which install stabilizer clamps onto crossmember.

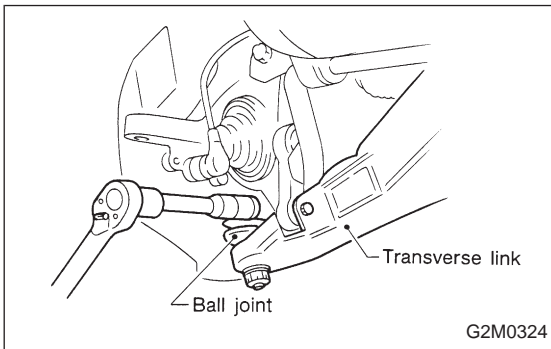

19) Remove front drive shafts from transmission.

- (1) Remove transverse link from housing.
- (2) Lower transverse link.

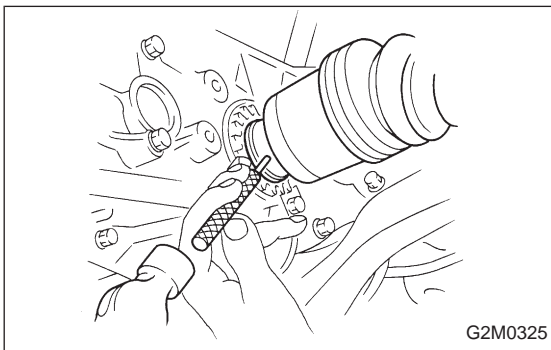

(3) Remove spring pins and separate front drive shafts from each side of the transmission.

**CAUTION:**

**Discard removing spring pin. Replace with a new one.**

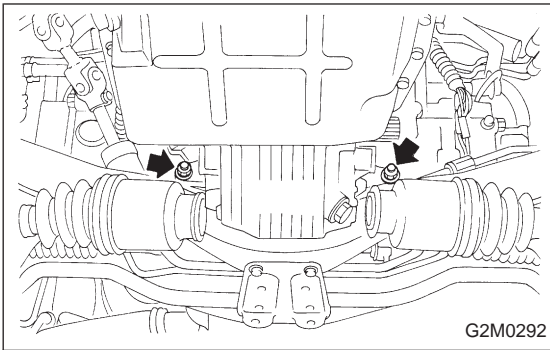

20) Remove nuts which hold lower side of transmission to engine.

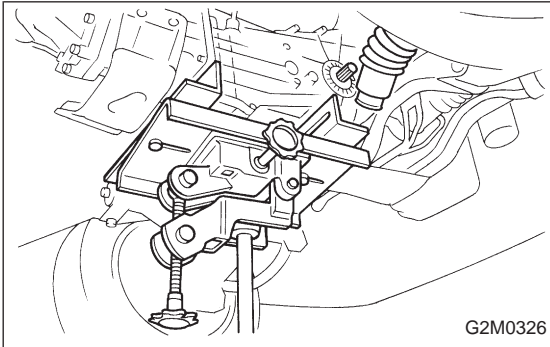

21) Place transmission jack under transmission.

**CAUTION:**

- Always support transmission case with a transmission jack.
- On AT model, make sure that the support plates of transmission jack don't touch the oil pan.

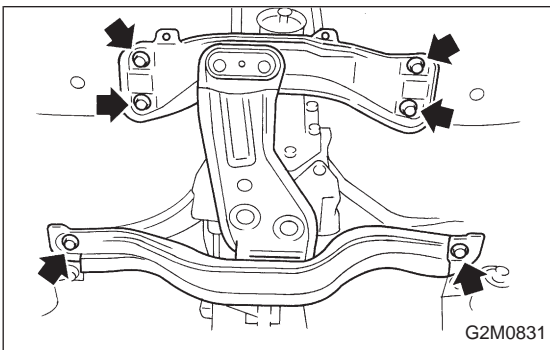

22) Remove transmission rear crossmember.

- MT model

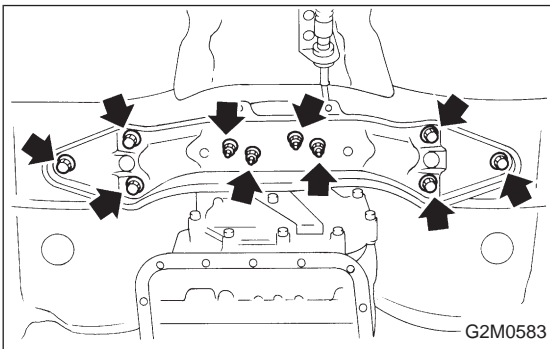

- AT model

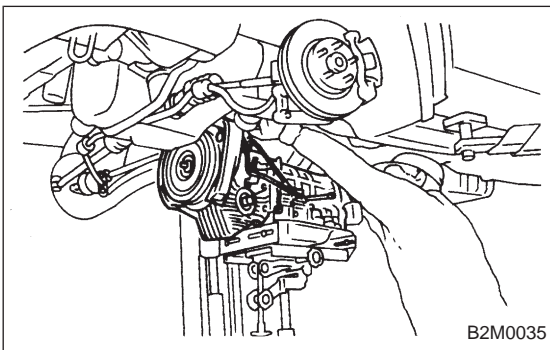

23) Remove transmission.

**CAUTION:**

- Move transmission jack toward rear until mainshaft is withdrawn from clutch cover. (MT model)
- Move transmission and torque converter as a unit away from engine. (AT model)

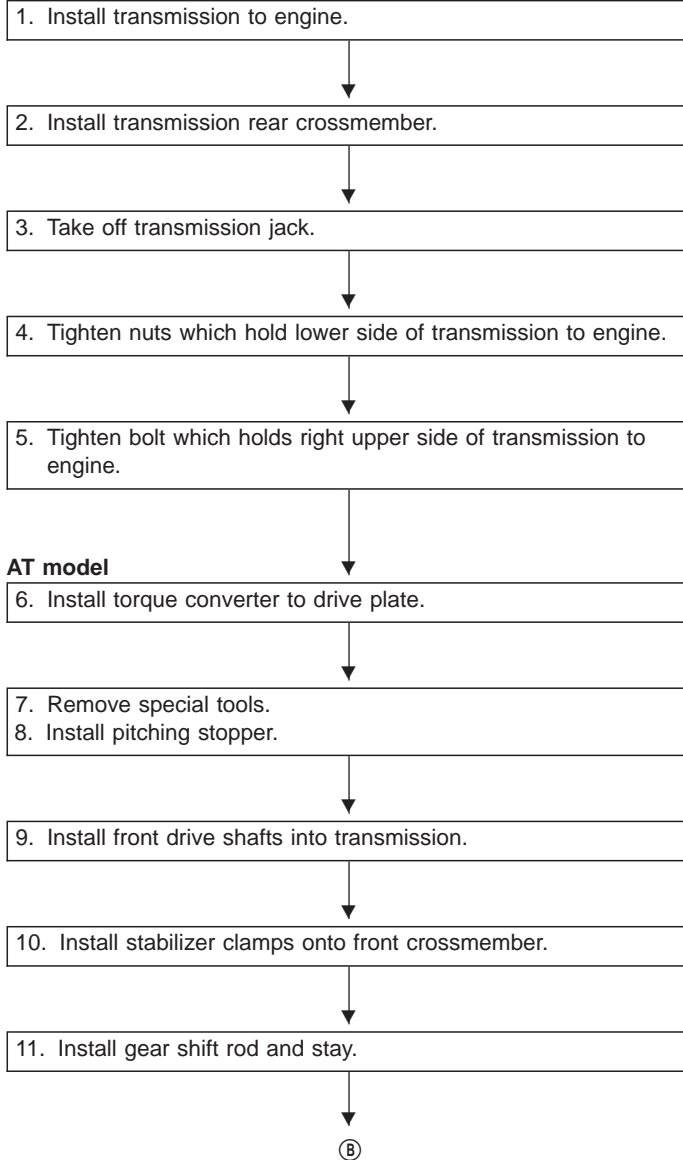
**B: INSTALLATION**



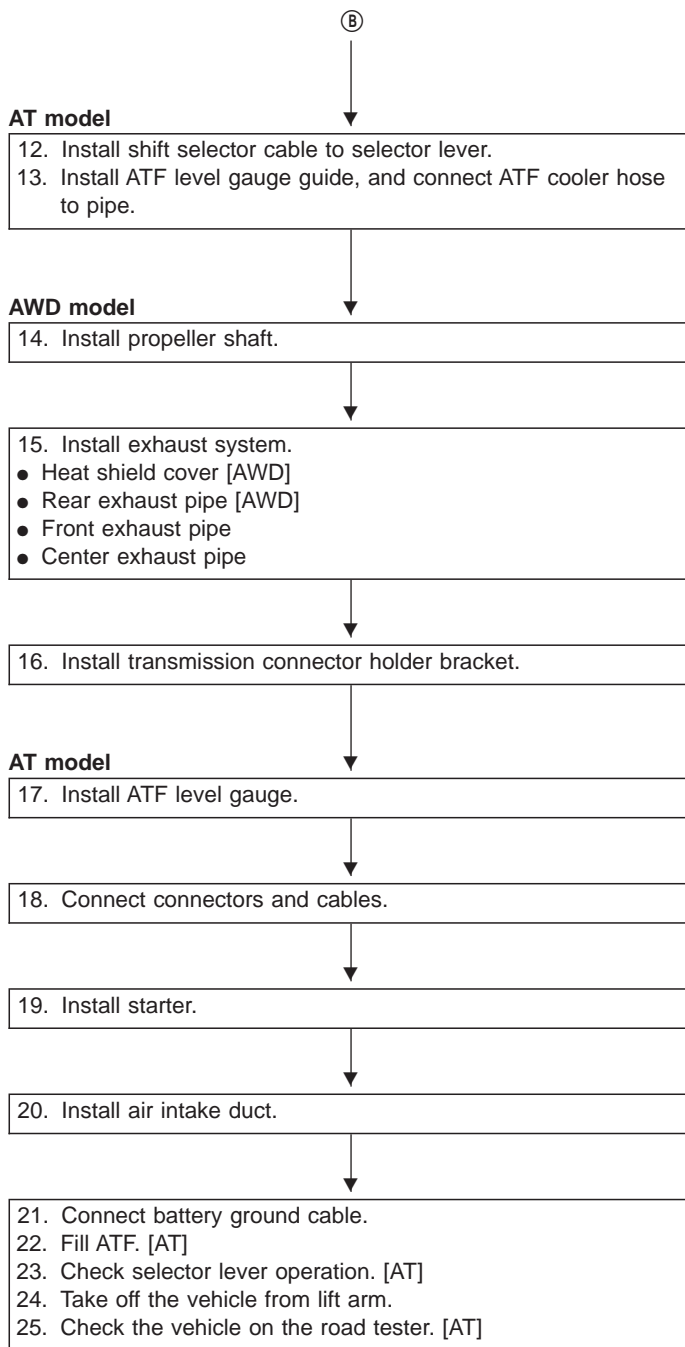

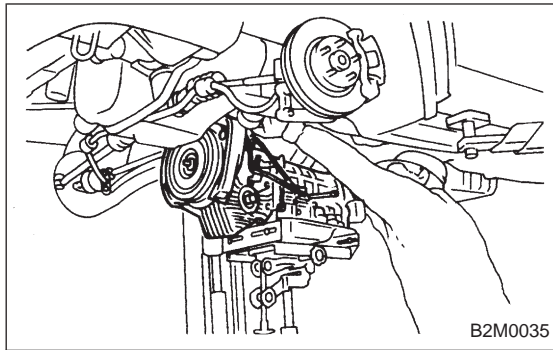

- 1) Install transmission onto engine.
  - (1) Gradually raise transmission with transmission jack.
  - (2) Engage them at splines.

**CAUTION:**

Be careful not to strike mainshaft against clutch cover.  
(MT model)

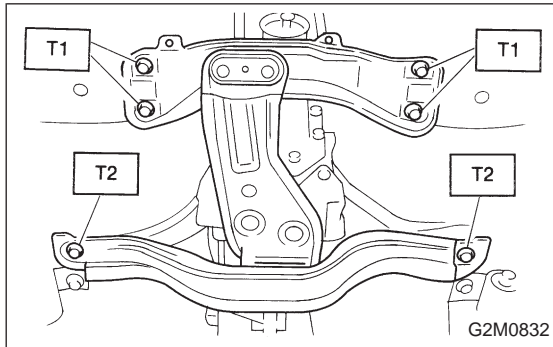

- 2) Install transmission rear crossmember.

- MT model

**Tightening torque:**

**T1:  $69\pm 15$  N·m ( $7.0\pm 1.5$  kg-m,  $51\pm 11$  ft-lb)**

**T2:  $137\pm 20$  N·m ( $14\pm 2$  kg-m,  $101\pm 14$  ft-lb)**

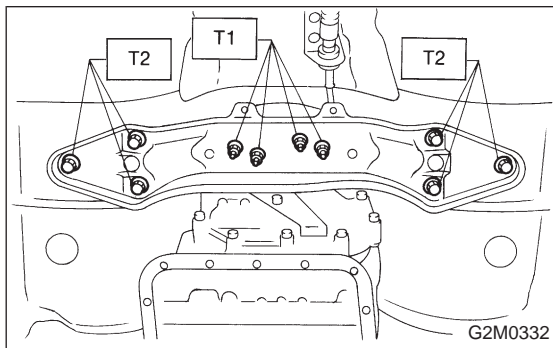

- AT model

**Tightening torque:**

**T1:  $18\pm 5$  N·m ( $1.8\pm 0.5$  kg-m,  $13.0\pm 3.6$  ft-lb)**

**T2:  $69\pm 15$  N·m ( $7.0\pm 1.5$  kg-m,  $51\pm 11$  ft-lb)**

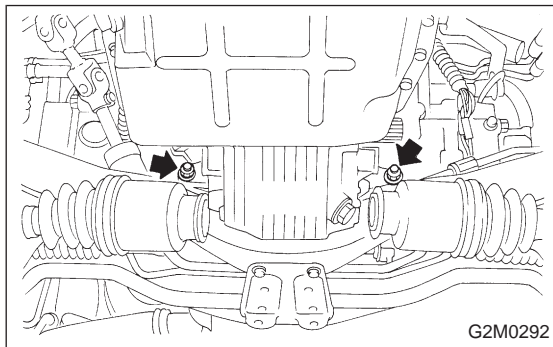

- 3) Take off transmission jack.
- 4) Tighten nuts which hold lower side of transmission to engine.

**Tightening torque:**

**$50\pm 4$  N·m ( $5.1\pm 0.4$  kg-m,  $36.9\pm 2.9$  ft-lb)**

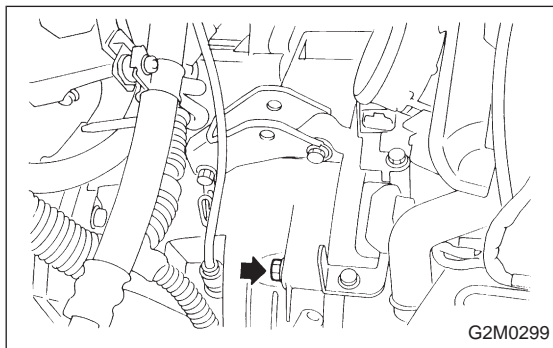

- 5) Tighten bolt which holds right upper side of transmission to engine.

**Tightening torque:**

**$50\pm 4$  N·m ( $5.1\pm 0.4$  kg-m,  $36.9\pm 2.9$  ft-lb)**

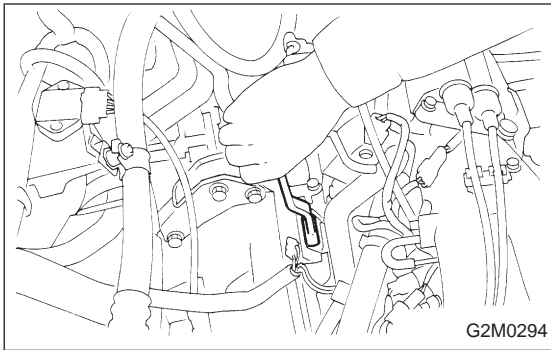

- 6) Install torque converter to drive plate. (AT model)
- (1) Tighten bolts which hold torque converter to drive plate.
  - (2) Tighten other bolts while rotating the engine by using ST.

ST 499977000 CRANK PULLEY WRENCH

**CAUTION:**

**Be careful not to drop bolts into torque converter housing.**

**Tightening torque:**

**$25\pm 2$  N·m ( $2.5\pm 0.2$  kg·m,  $18.1\pm 1.4$  ft·lb)**

- (3) Clog plug onto service hole.

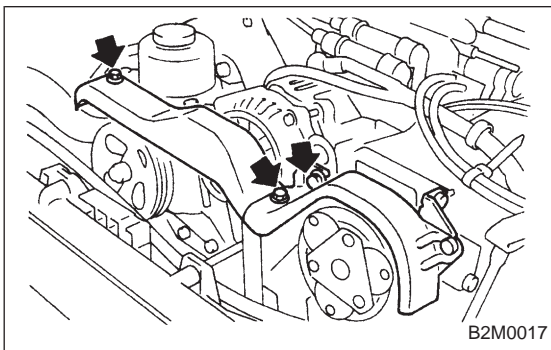

- (4) Install V-belt cover.

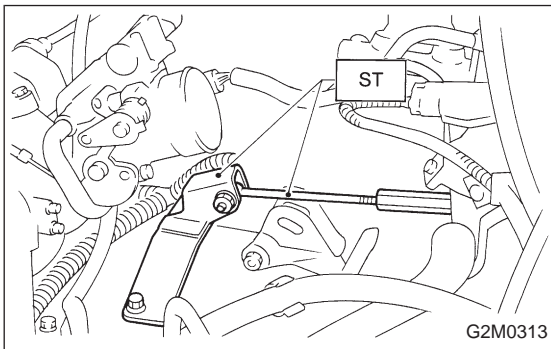

- 7) Remove special tools.

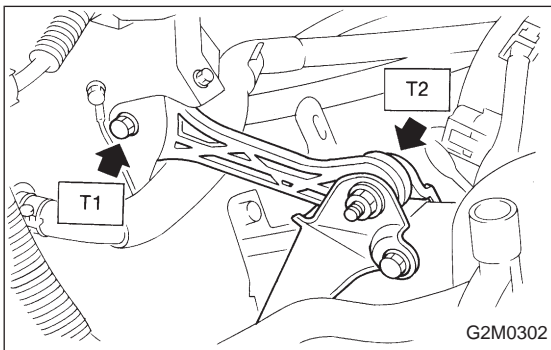

- 8) Install pitching stopper.

**Tightening torque:**

**$T1$ :  $49\pm 5$  N·m ( $5.0\pm 0.5$  kg·m,  $36.2\pm 3.6$  ft·lb)**

**$T2$ :  $57\pm 10$  N·m ( $5.8\pm 1.0$  kg·m,  $42\pm 7$  ft·lb)**

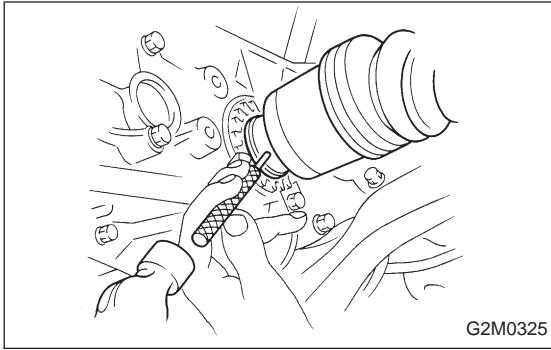

- 9) Install front drive shafts into transmission.
  - (1) Lift-up the vehicle.
  - (2) Install front drive shaft into transmission.
  - (3) Drive spring pin into chamfered hole of drive shaft.

**CAUTION:**

**Always use a new spring pin.**

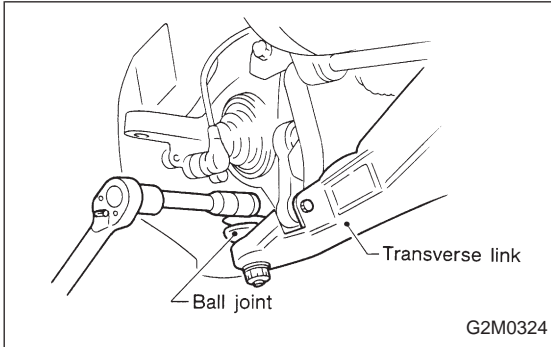

- (4) Install ball joints of lower arm into knuckle arm of housing, and tighten installing bolts.

**Tightening torque:**

**$49\pm 10$  N·m ( $5.0\pm 1.0$  kg·m,  $36\pm 7$  ft·lb)**

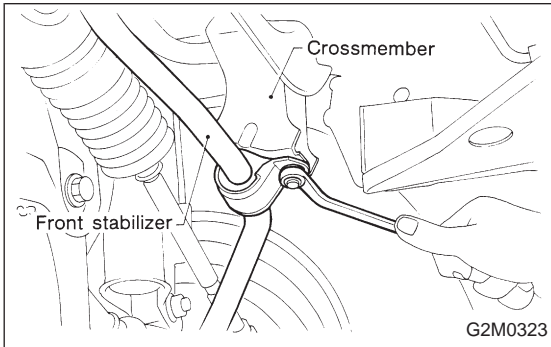

- 10) Install stabilizer clamps onto front crossmember.

**Tightening torque:**

**$25\pm 4$  N·m ( $2.5\pm 0.4$  kg·m,  $18.1\pm 2.9$  ft·lb)**

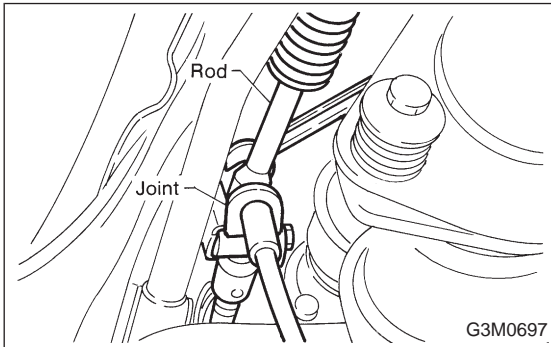

- 11) Install gear shift rod and stay. (MT model)

- (1) Install gear shift rod onto transmission.
- (2) Install stay onto transmission.
- (3) Install spring.

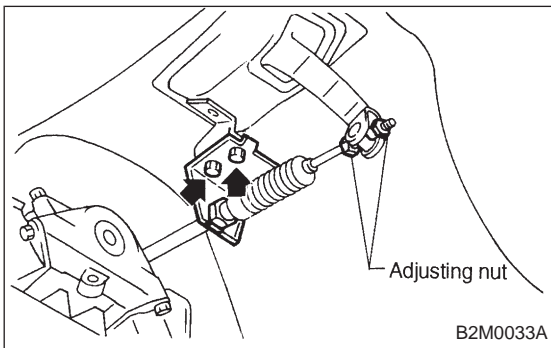

- 12) Install shift selector cable onto selector lever. (AT model)

- (1) Install selector cable into selector lever.
- (2) Install cable bracket onto body.

**NOTE:**

Tighten selector cable adjusting and lock nut after checking selector lever operation [step. 24)].

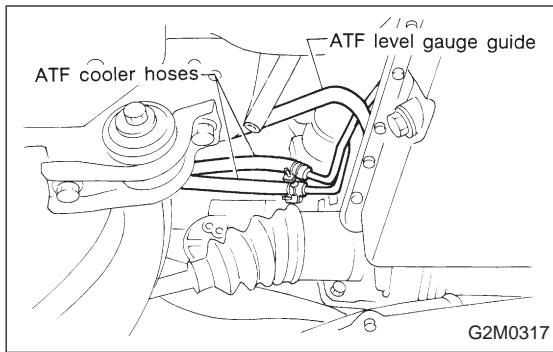

13) Install ATF level gauge guide, and ATF cooler hoses onto pipe. (AT model)

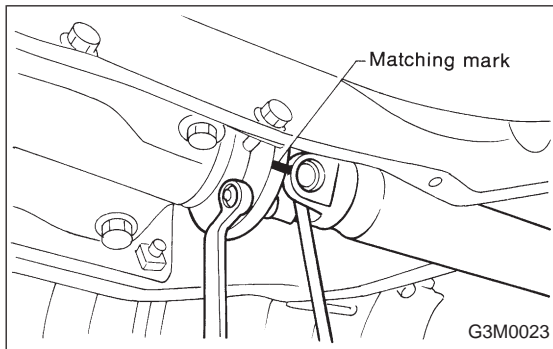

14) Install propeller shaft. (AWD model)  
 (1) Install propeller shaft into transmission.  
 (2) Tighten bolts which install propeller shaft onto companion flange of rear differential.

**Tightening torque:**  
 $31 \pm 8 \text{ N}\cdot\text{m}$  ( $3.2 \pm 0.8 \text{ kg}\cdot\text{m}$ ,  $23.1 \pm 5.8 \text{ ft}\cdot\text{lb}$ )

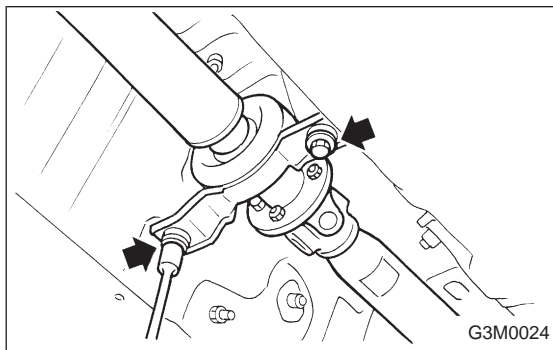

(3) Install center bearing bracket on body.  
**Tightening torque:**  
 $52 \pm 5 \text{ N}\cdot\text{m}$  ( $5.3 \pm 0.5 \text{ kg}\cdot\text{m}$ ,  $38.3 \pm 3.6 \text{ ft}\cdot\text{lb}$ )

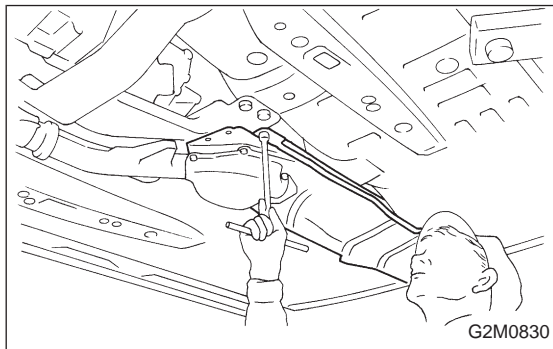

15) Install exhaust system.  
 (1) Install heat shield cover. (AWD model)

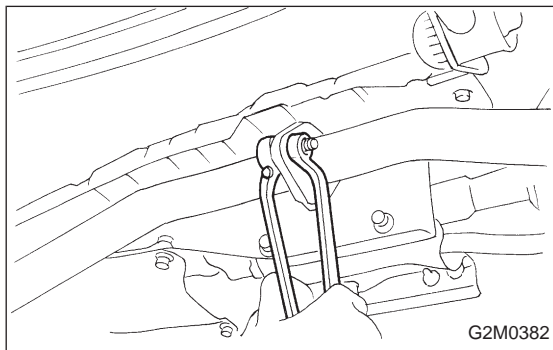

(2) Install rear exhaust pipe to muffler. (AWD model)  
**Tightening torque:**  
 $48 \pm 9 \text{ N}\cdot\text{m}$  ( $4.9 \pm 0.9 \text{ kg}\cdot\text{m}$ ,  $35.4 \pm 6.5 \text{ ft}\cdot\text{lb}$ )

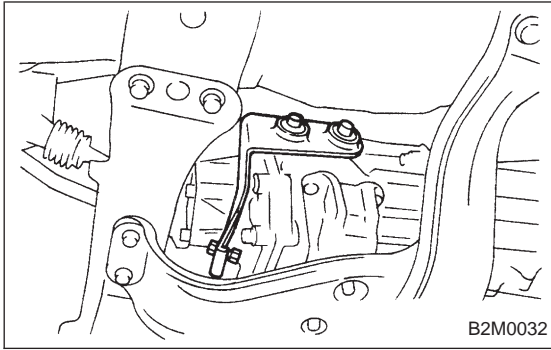

- (3) Install hanger bracket on right side of transmission.  
(AWD model)

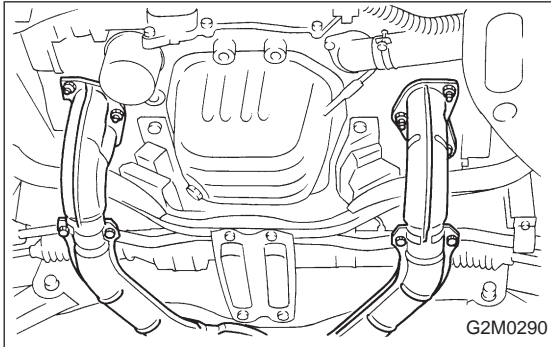

- (4) Install front exhaust pipe onto engine.  
**Tightening torque:**  
 **$30\pm 5$  N·m ( $3.1\pm 0.5$  kg·m,  $22.4\pm 3.6$  ft·lb)**

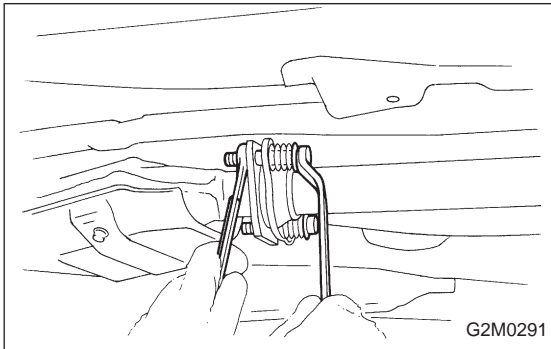

- (5) Install center exhaust pipe to rear exhaust pipe.  
**Tightening torque:**  
 **$18\pm 5$  N·m ( $1.8\pm 0.5$  kg·m,  $13.0\pm 3.6$  ft·lb)**

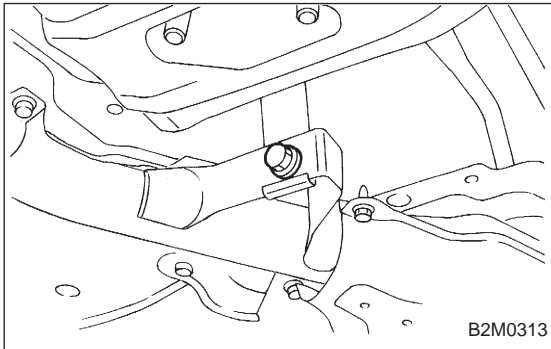

- (6) Tighten bolt which installs center exhaust pipe to hanger bracket.  
**Tightening torque:**  
 **$30\pm 5$  N·m ( $3.1\pm 0.5$  kg·m,  $22.4\pm 3.6$  ft·lb)**

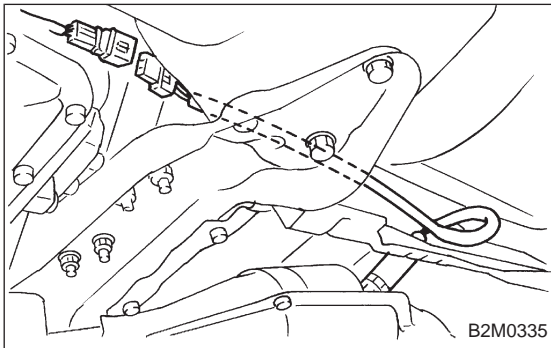

- (7) Connect connector to rear oxygen sensor.

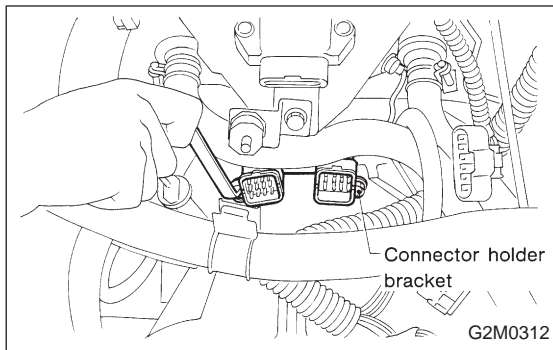

16) Install transmission connector holder bracket.

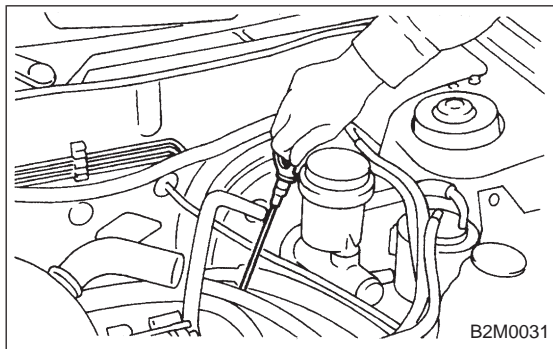

17) Install ATF level gauge. (AT model)

18) Connect connectors and cables.

(1) Connect the following connectors.

- Transmission harness connectors
- Transmission ground terminal
- Front oxygen sensor connector
- Vehicle speed sensor 2
- Neutral position switch connector (MT model)
- Back-up light switch connector (MT model)

(2) Connect the following cables.

- Cruise control cable  
(With cruise control model)
- Clutch cable

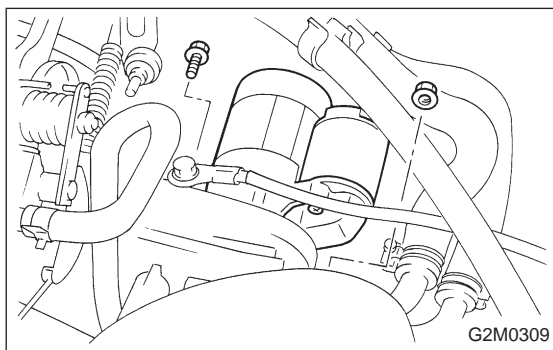

19) Install starter.

(1) Install starter onto transmission case, and connect connectors and terminals.

(2) Tighten bolt and nut which install starter onto transmission.

**Tightening torque:**

**$40 \pm 4$  N·m ( $4.1 \pm 0.4$  kg·m,  $29.7 \pm 2.9$  ft·lb)**

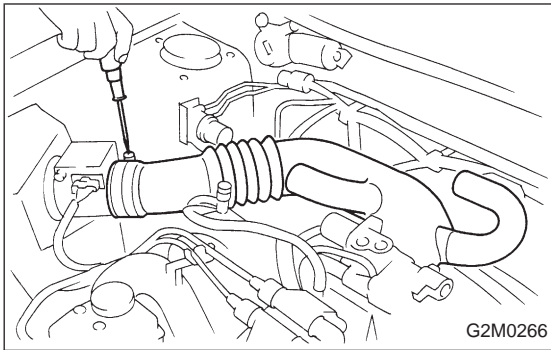

20) Install air intake duct.

21) Connect battery ground cable.

22) Fill ATF. (AT model)

<Ref. to 3-2 [W2A1].>

23) Check selector lever operation. (AT model)

<Ref. to 3-3 [W2E0].>

24) Take off vehicle from lift arms.

25) Check the vehicle on road tester. (AT model)

<Ref. to 3-2 [W3E0].>