

## 8. Front Fender **AIRBAG**

### A: REMOVAL

#### SUPPLEMENTAL RESTRAINT SYSTEM "AIRBAG"

Airbag system wiring harness is routed near the front fender.

#### CAUTION:

- All Airbag system wiring harness and connectors are colored yellow. Do not use electrical test equipment on these circuits.
- Be careful not to damage Airbag system wiring harness when servicing the front fender.

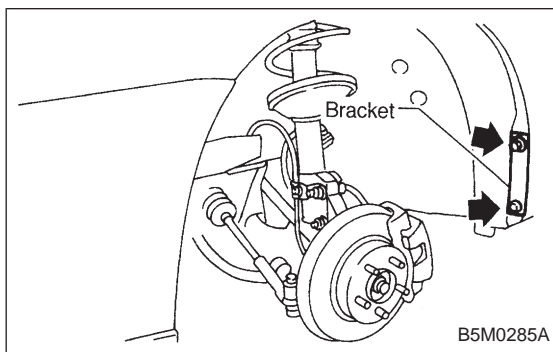

- 1) Disconnect ground cable from battery.
- 2) Remove bracket which secures mud guard to front fender.
- 3) Remove mud guard. <Ref. to 5-1 [W9A1].>

#### NOTE:

Do not remove the entire mud guard, only the front section of it.

- 4) Remove headlight. <Ref. to 6-2 [W4B2].>

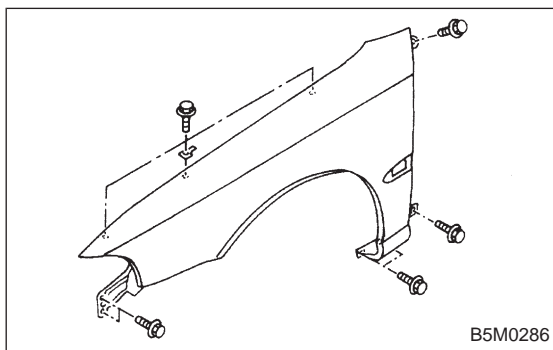

- 5) Remove bolts which secure front fender. Remove front fender.

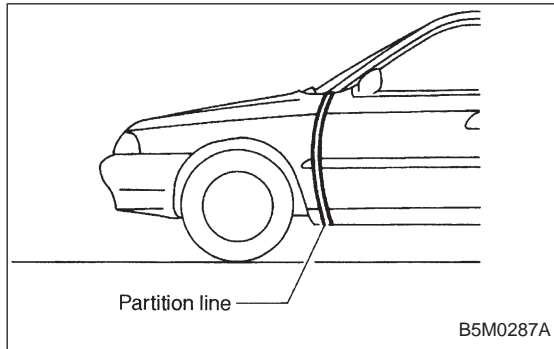
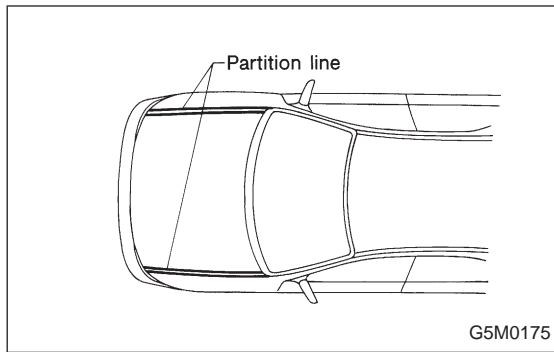

## B: INSTALLATION

- 1) Installation is in the reverse order of removal.
- 2) Check for alignment of front fender with hood and front door with front fender at all points. Adjust, if necessary.

## 9. Mud Guard and Rear Arch Protector **AIRBAG**

### A: REMOVAL

#### SUPPLEMENTAL RESTRAINT SYSTEM "AIRBAG"

Airbag system wiring harness is routed near the mud guard.

#### CAUTION:

- All Airbag system wiring harness and connectors are colored yellow. Do not use electrical test equipment on these circuits.
- Be careful not to damage Airbag system wiring harness when servicing the mud guard.

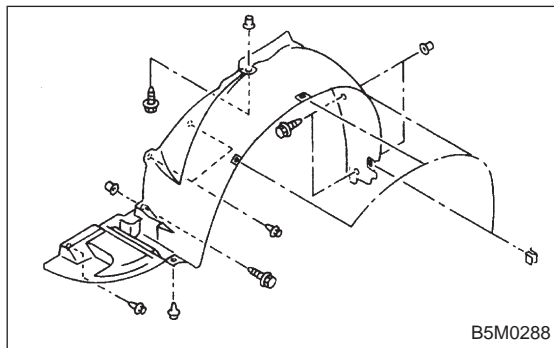

### 1. MUD GUARD (EXCEPT OUTBACK WITH STEP ROOF)

- 1) Jack-up vehicle to remove tire.
- 2) Remove screws and clips. Move mud guard toward the center of the body and remove mud guard.