

6. Turn Signal and Hazard Warning Light

A: REMOVAL AND INSTALLATION

1. FRONT TURN SIGNAL LIGHT

Refer to 6-2 [W4B2] as for removal and installation of front turn signal light.

NOTE:

The front turn signal light is united with headlight assembly.

2. REAR COMBINATION LIGHT

Refer to 6-2 [W5A1] as for removal and installation of rear combination light.

3. COMBINATION SWITCH

Refer to 6-2 [W4B3] as for removal and installation of combination switch.

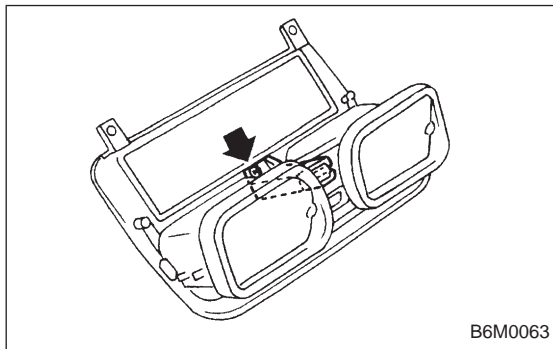

4. HAZARD SWITCH

- 1) Remove center panel from instrument panel. <Ref. to 5-4 [W1A0].>
- 2) Disconnect connector of hazard switch from body harness.
- 3) Remove hazard switch from center panel.

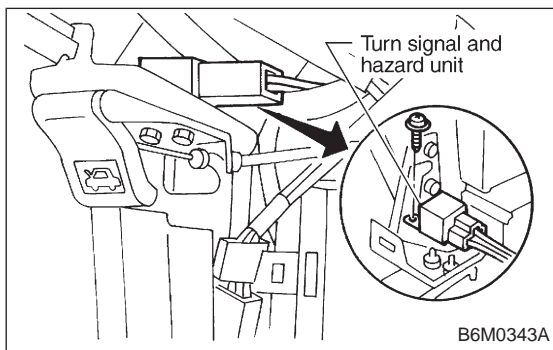

5. TURN SIGNAL AND HAZARD UNIT

- 1) Remove instrument panel lower cover.
- 2) Remove engine hood opener lever bracket.
- 3) Disconnect connector of turn signal and hazard unit.
- 4) Remove screw, and then remove turn signal and hazard unit from bracket.

B: DISASSEMBLY AND ASSEMBLY

1. COMBINATION SWITCH

Refer to 6-2 [W4C1] as for disassembly and assembly of combination switch.

C: INSPECTION

1. COMBINATION SWITCH (ON-CAR)

- 1) Remove instrument panel lower cover.
- 2) Remove lower column cover.

- 3) Unfasten holddown clip which secures harness, and disconnect connectors from body harness.
- 4) Move combination switch to respective positions and check continuity between terminals as indicated in table below:

Turn signal switch

Switch position	Terminal	a-5	a-7	a-6
Turn	L·L'	○	○	
	↓	x		x
	N			
	↑	x		x
	R·R'		○	○

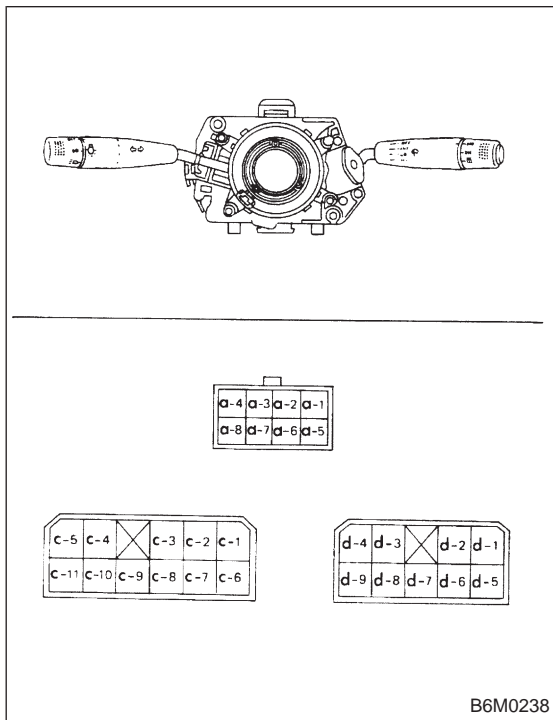

2. HAZARD SWITCH

Move hazard switch to each position and check continuity between terminals as indicated in table below:

	7	3	9	10	5	6	1	2
ON	○		○	○	○	○	○	○
OFF	○	○					○	○

