

## 7. EGR Solenoid Valve

### A: REMOVAL AND INSTALLATION

- 1) Remove bolt which installs EGR solenoid valve onto intake manifold.
- 2) Disconnect hoses and connector from EGR solenoid valve.

**NOTE:**

This figure shows the rear side of intake manifold.

- 3) Installation is in the reverse order of removal.

**Tightening torque:**

**19±5 N·m (1.9±0.5 kg·m, 13.7±3.6 ft·lb)**

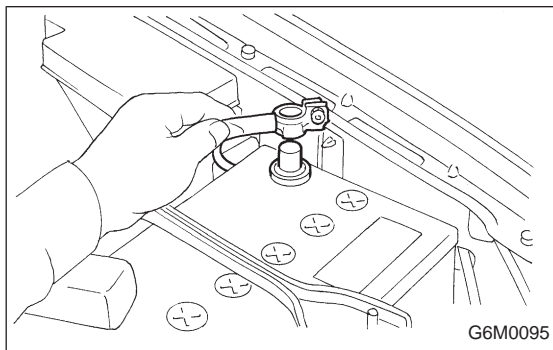

## 8. Fuel Temperature Sensor (2200 cc AWD Model)

### A: REMOVAL

- 1) Disconnect battery ground cable.

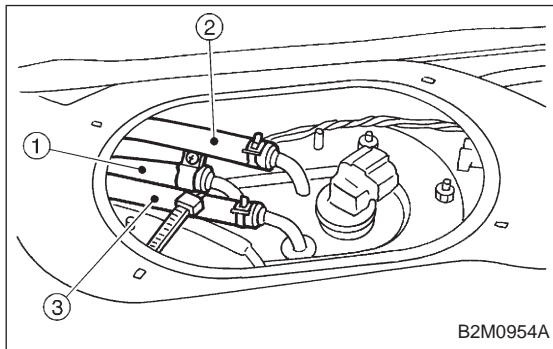

- 2) Release fuel pressure. <Ref. to 2-8 [W1A0].>

- 3) Disconnect fuel delivery hose ①, return hose ② and jet pump hose ③.

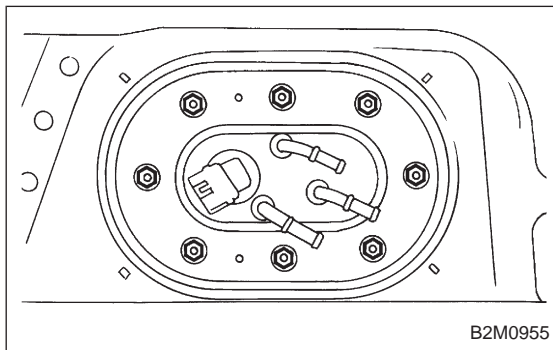

- 4) Remove nuts which install fuel pump assembly onto fuel tank.

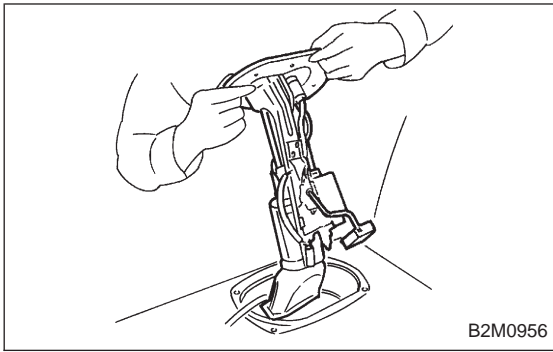

5) Take off fuel pump assembly from fuel tank.

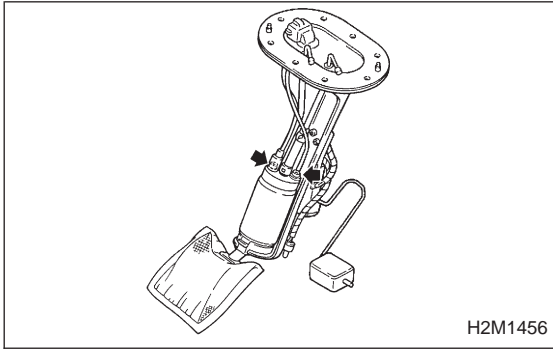

6) Remove two screws fixing terminals on fuel pump assembly.

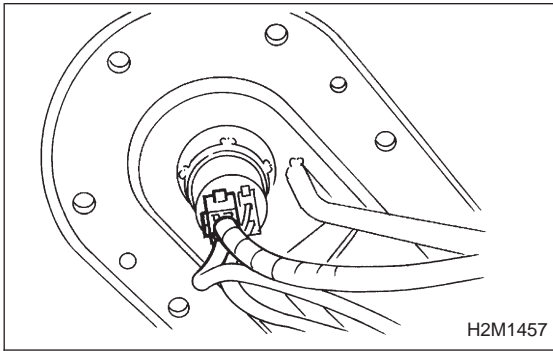

7) Disconnect connector from fuel pump.

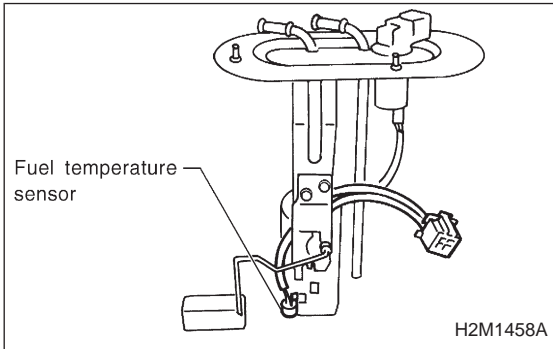

8) Remove fuel temperature sensor from fuel pump assembly.

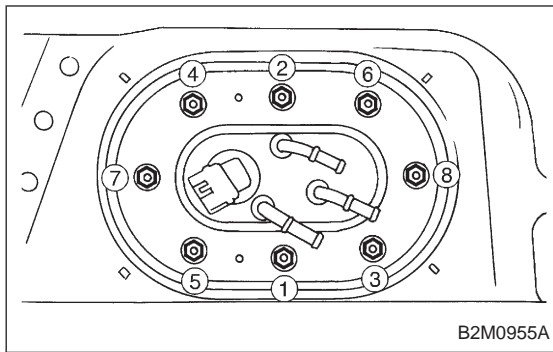

**B: INSTALLATION**

**CAUTION:**

Leave fuel filler cap open when tightening nuts, to prevent fuel from flowing out through fuel delivery and return pipes. Close fuel filler cap after tightening nuts.

Installation is in the reverse order of removal. Do the following:

- (1) Always use new gaskets.
- (2) Ensure sealing portion is free from fuel or foreign particles before installation.
- (3) Tighten nuts in numerical sequence shown in Figure to specified torque.

**Tightening torque:**

***4.4±1.5 N·m (0.45±0.15 kg-m, 3.3±1.1 ft-lb)***

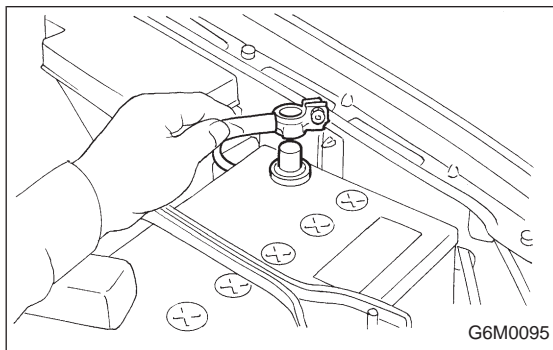

**9. Fuel Tank Pressure Sensor (2200 cc AWD Model)**

**A: REMOVAL AND INSTALLATION**

1) Disconnect battery ground cable.

2) Remove trims.

● 4 door model:

Remove right trunk side trim.

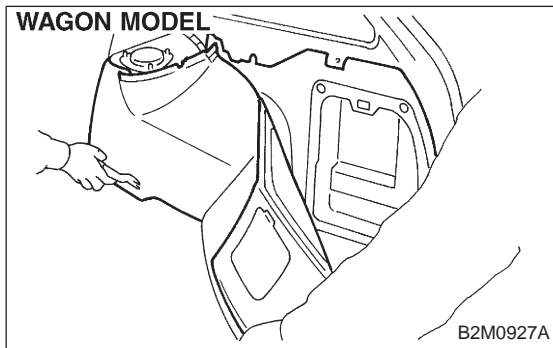
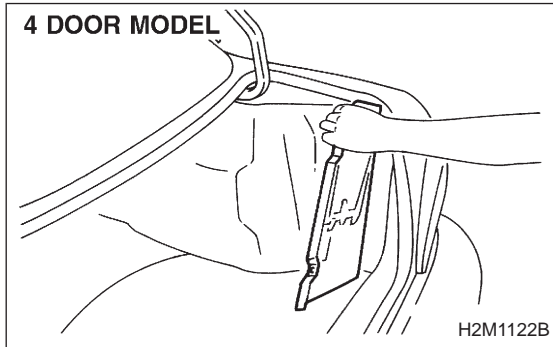

● Wagon model:

- (1) Remove right rear quarter upper rear trim.
- (2) Remove right strut cap.
- (3) Remove right rear quarter pillar lower trim.