

3. Timing Belt

A: REMOVAL

1. CRANKSHAFT PULLEY AND BELT COVER

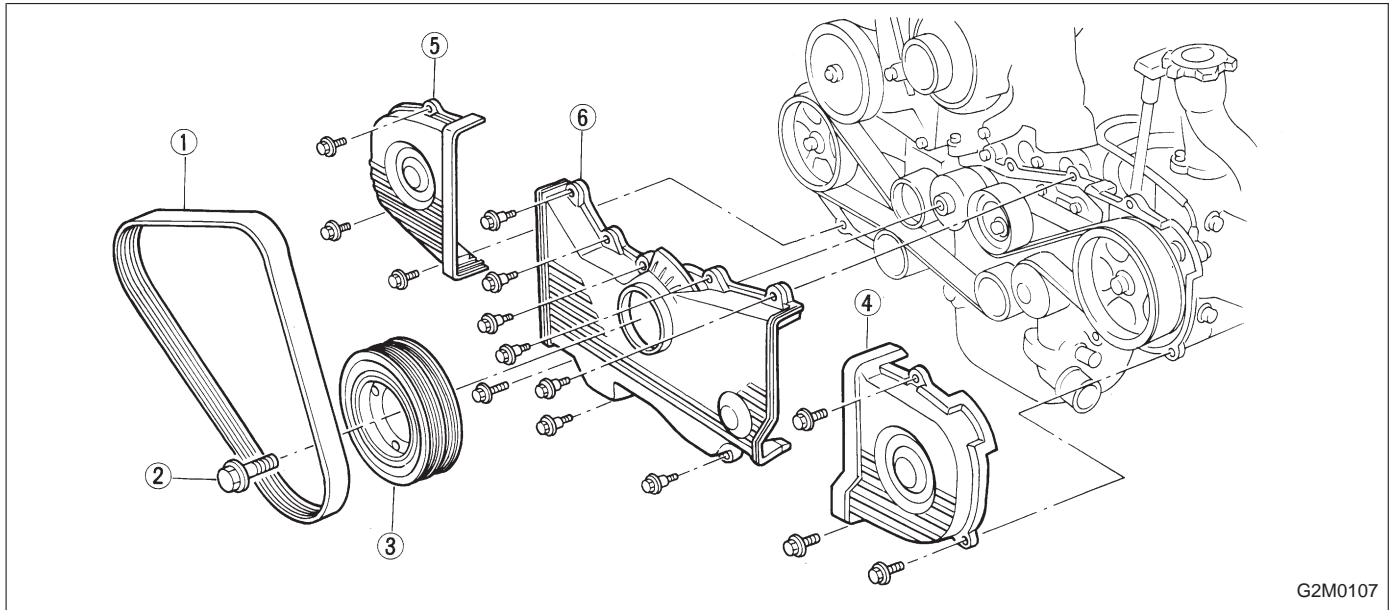

G2M0107

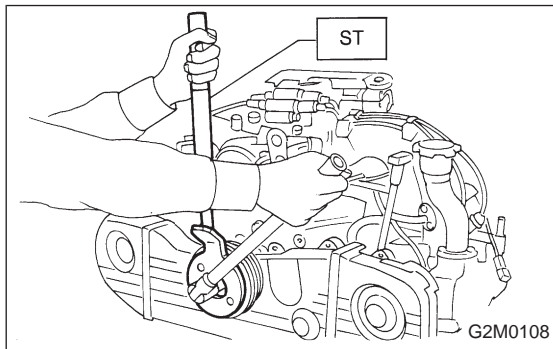

G2M0108

- 1) Remove V-belt and A/C belt tensioner.
- 2) Remove pulley bolt. To lock crankshaft use ST.
ST 499977000 CRANKSHAFT PULLEY WRENCH
- 3) Remove crankshaft pulley.
- 4) Remove left side belt cover.
- 5) Remove right side belt cover.
- 6) Remove front belt cover.

2. TIMING BELT

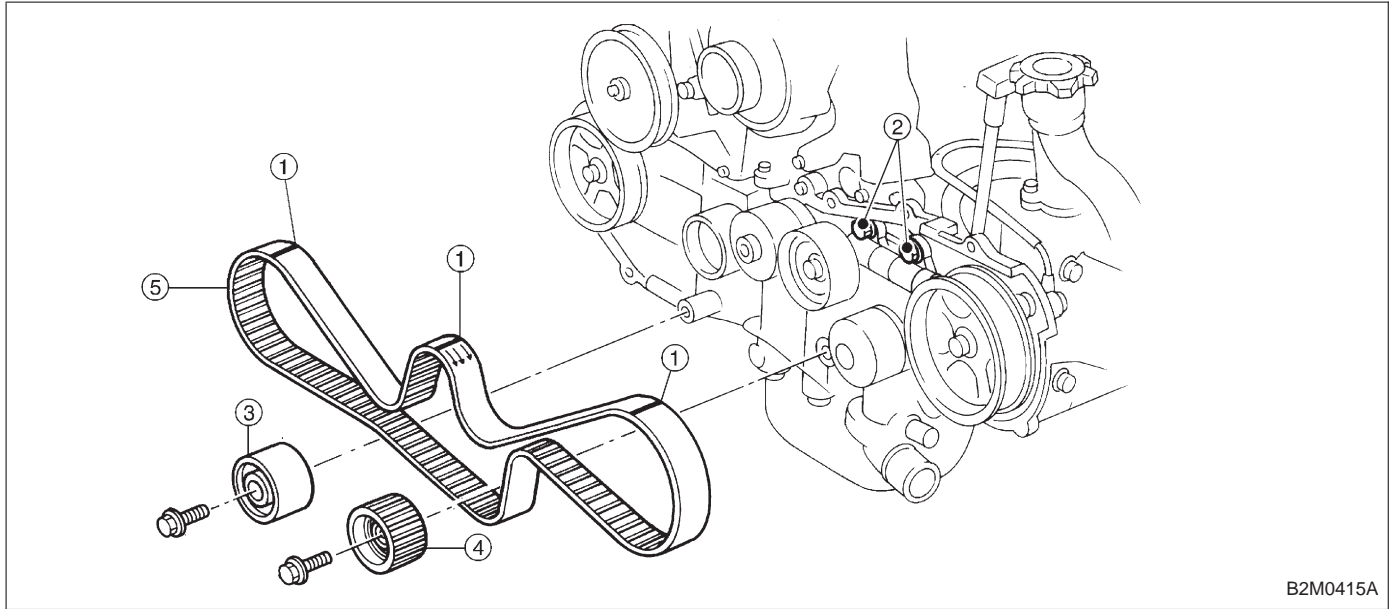

B2M0415A

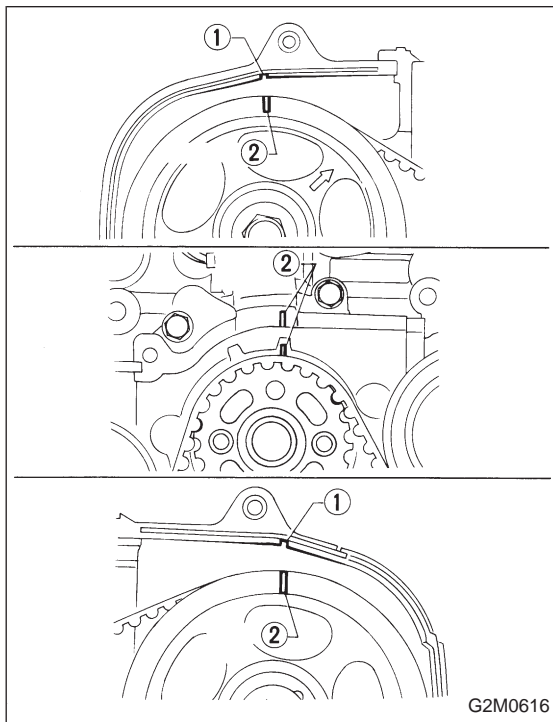

G2M0616

1) If alignment mark ② and/or arrow mark (which indicates rotation direction) on timing belt fade away, put new marks before removing timing belt as follows:

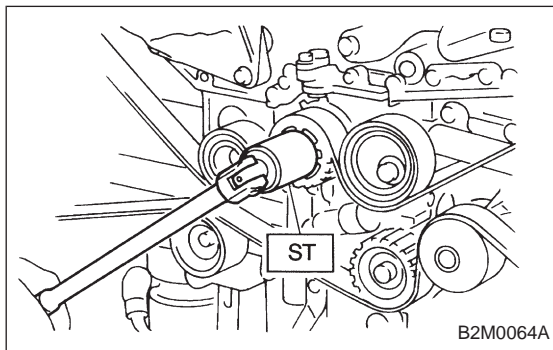

B2M0064A

(1) Turn crankshaft, and align alignment marks ② on crankshaft sprocket, and left and right camshaft sprockets with notches ① of belt cover and cylinder block.

ST 499987500 CRANKSHAFT SOCKET

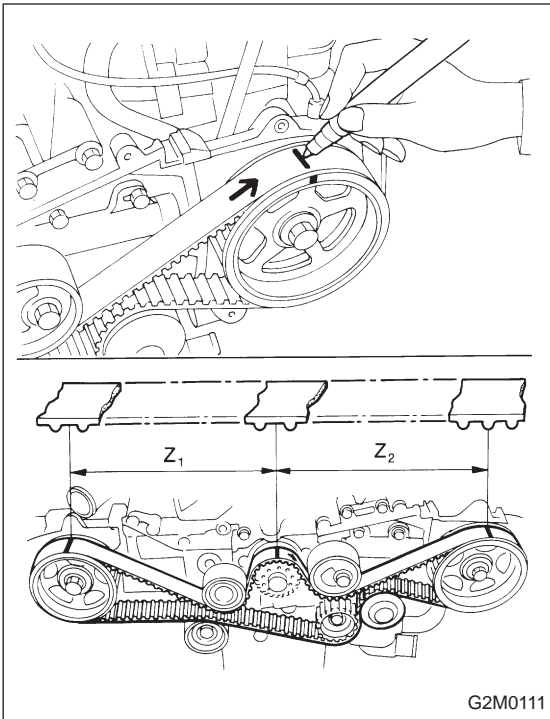

(2) Using white paint, put alignment and/or arrow marks on timing belts in relation to the sprockets.

Z_1 : 44 tooth length
 Z_2 : 40.5 tooth length

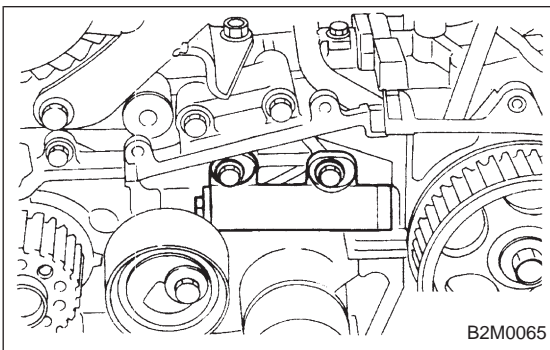

2) Loosen tensioner adjuster mounting bolts.

- 3) Remove belt idler.
- 4) Remove belt idler No. 2.
- 5) Remove timing belt.
- 6) Remove tensioner adjuster.

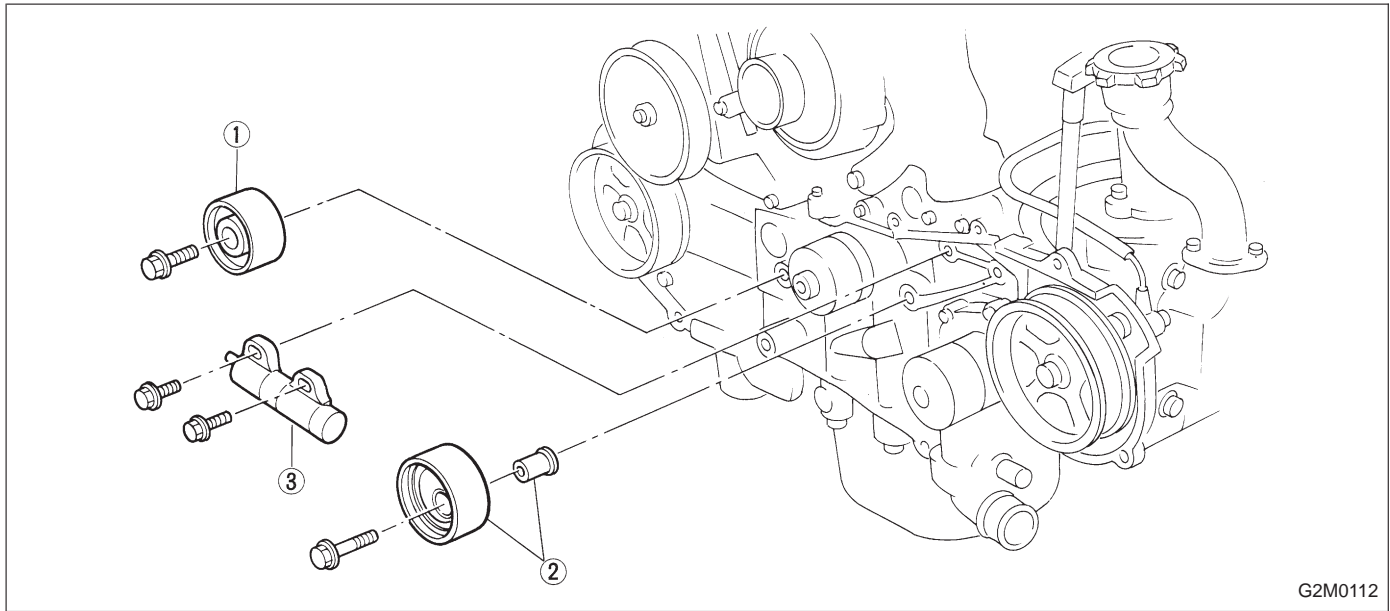
3. BELT TENSIONER AND IDLER

G2M0112

- 1) Remove belt idler.
- 2) Remove belt tensioner and spacer.
- 3) Remove belt tensioner adjuster.

4. SPROCKET

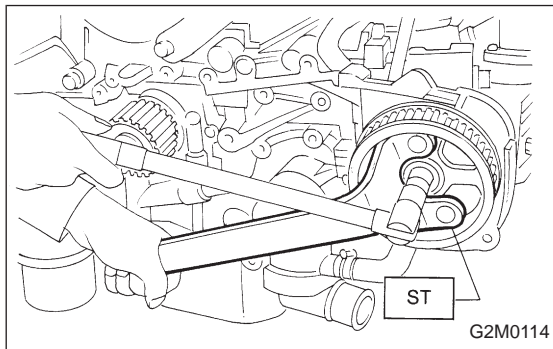
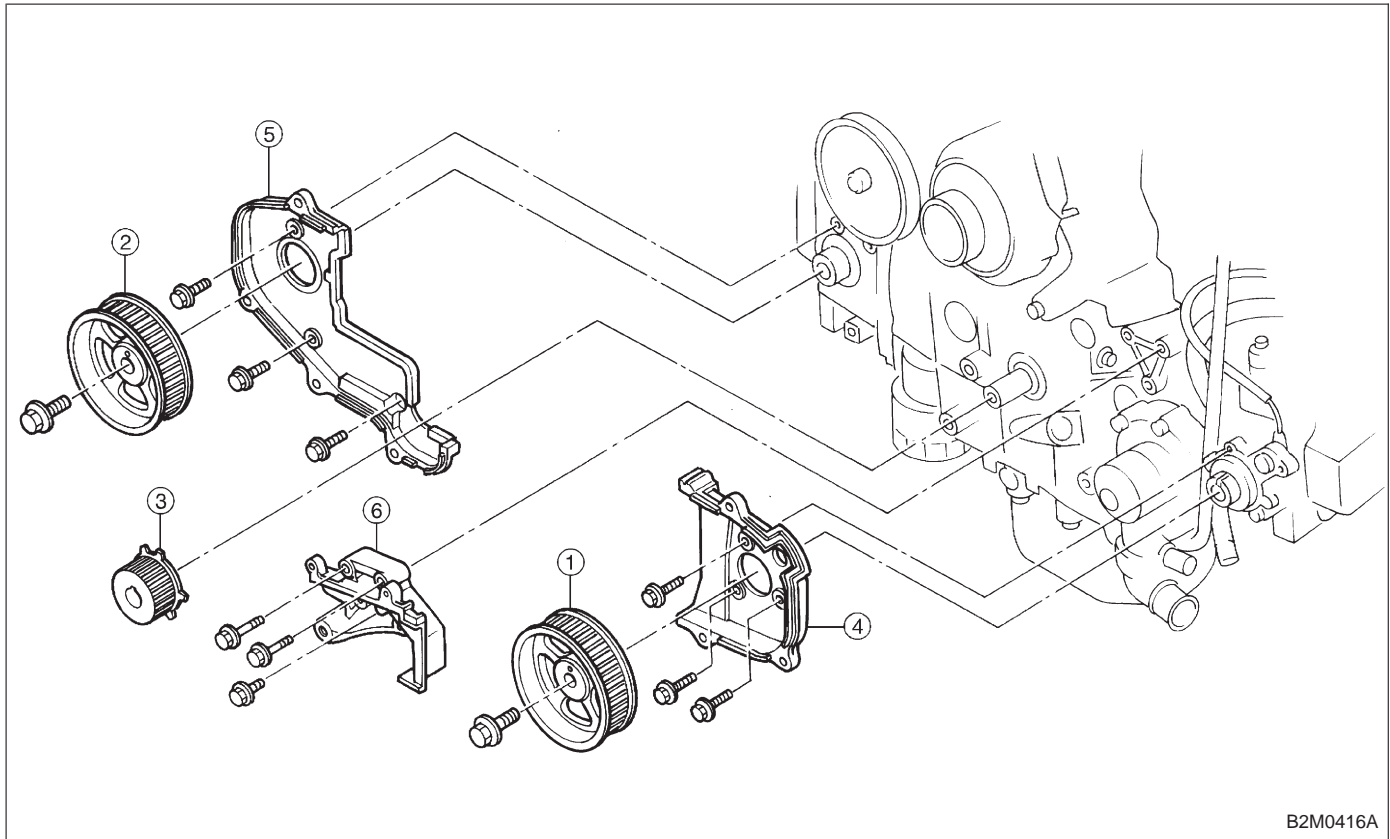

- 1) Remove left side camshaft sprocket.
- 2) Remove right side camshaft sprocket. To lock camshaft use ST.
ST 499207100 CAMSHAFT SPROCKET WRENCH

- 3) Remove crankshaft sprocket.
- 4) Remove left side belt cover No. 2.
- 5) Remove right side belt cover No. 2.

CAUTION:
Do not damage or lose the seal rubber when removing belt covers.

- 6) Remove tensioner bracket.

B: INSPECTION**1. TIMING BELT**

- 1) Check timing belt teeth for breaks, cracks, and wear. If any fault is found, replace belt.
- 2) Check the condition of back side of belt; if any crack is found, replace belt.

CAUTION:

- Be careful not to let oil, grease or coolant contact the belt. Remove quickly and thoroughly if this happens.

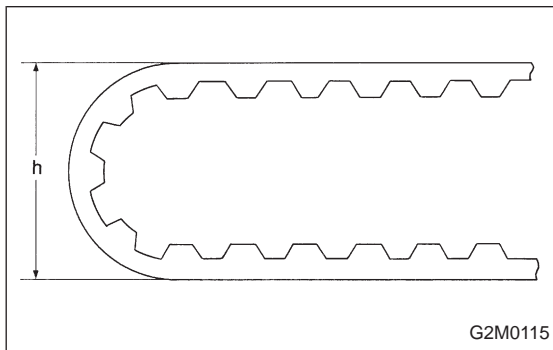

- Do not bend the belt sharply.

**Bending radius: h
60 mm (2.36 in) or more**

2. BELT TENSION ADJUSTER

- 1) Visually check oil seals for leaks, and rod ends for abnormal wear or scratches. If necessary, replace belt tension adjuster.

CAUTION:

Slight traces of oil at rod's oil seal does not indicate a problem.

- 2) While holding tensioner with both hands, push the rod section against floor or wall ensuring the rod section will react as follows:

- (1) When applying a force of 147 N (15 kg, 33 lb), the rod section should not sink.
- (2) When applying a force of 147 to 490 N (15 to 50 kg, 33 to 110 lb), the rod section should maintain a projectionally acting force and should not sink within 8.5 seconds.

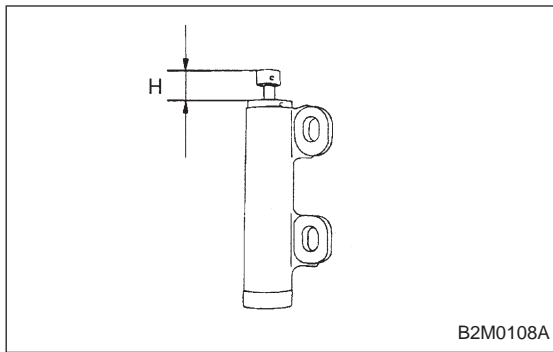

3) Measure the extension of rod beyond the body. If it is not within specifications, replace with a new one.

Rod extension: H

15.4 — 16.4 mm (0.606 — 0.646 in)

3. BELT TENSIONER

- 1) Check mating surfaces of timing belt and contact point of tension adjuster rod for abnormal wear or scratches. Replace belt tensioner if faulty.
- 2) Check spacer and tensioner bushing for wear.
- 3) Check tensioner for smooth rotation. Replace if noise or excessive play is noted.
- 4) Check tensioner for grease leakage.

4. BELT IDLER

- 1) Check idler for smooth rotation. Replace if noise or excessive play is noted.
- 2) Check outer contacting surfaces of idler pulley for abnormal wear and scratches.
- 3) Check idler for grease leakage.

5. SPROCKET

- 1) Check sprocket teeth for abnormal wear and scratches.
- 2) Make sure there is no free play between sprocket and key.
- 3) Check crankshaft sprocket notch for sensor for damage and contamination of foreign matter.

C: INSTALLATION

1. SPROCKET

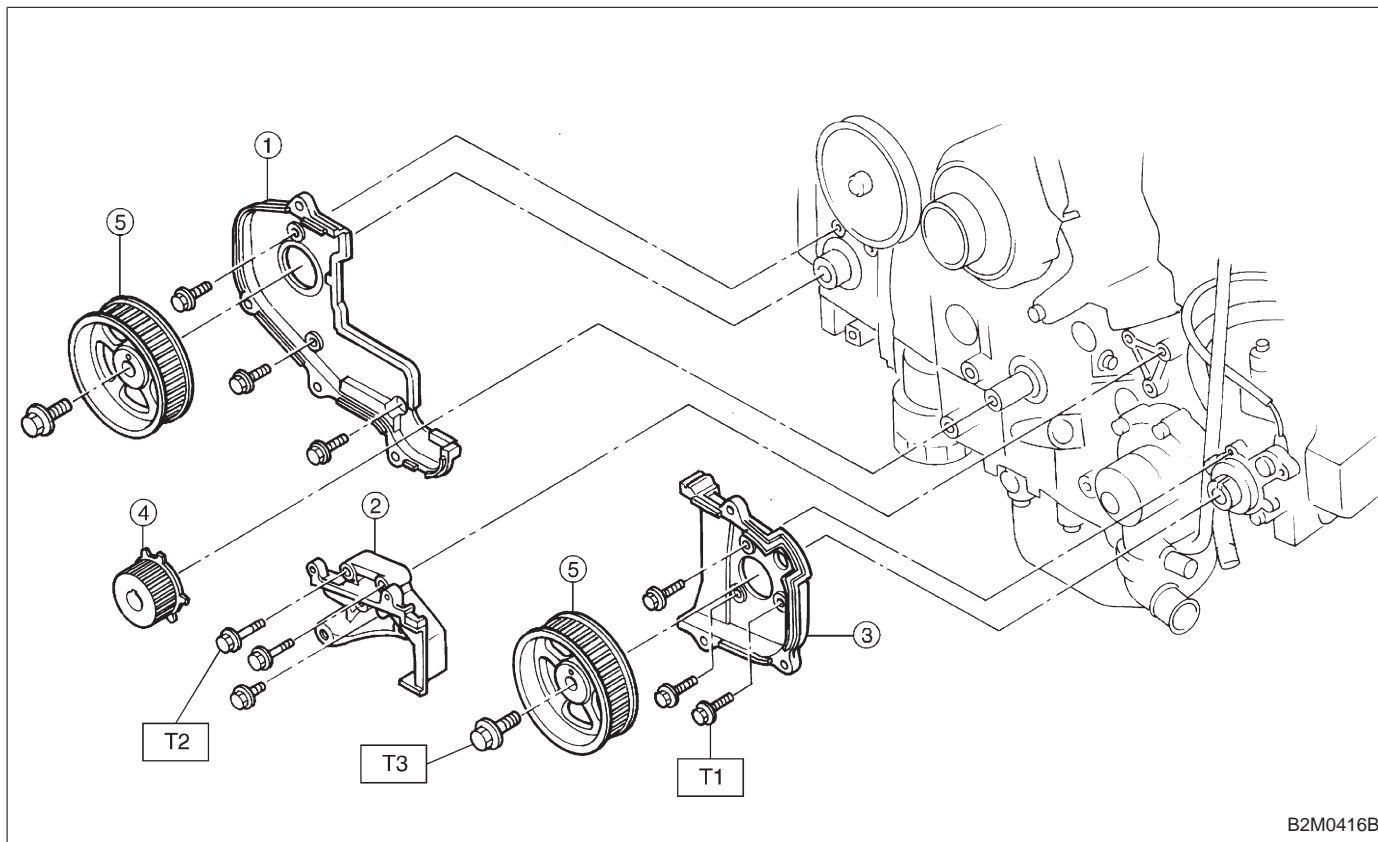

Tightening torque: N·m (kg·m, ft·lb)

T1: 5±1 (0.5±0.1, 3.6±0.7)

T2: 25±2 (2.5±0.2, 18.1±1.4)

T3: 78±5 (8.0±0.5, 57.9±3.6)

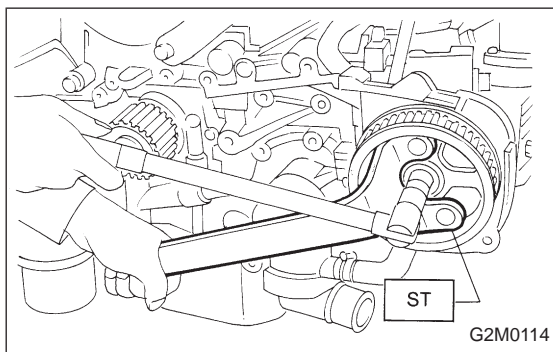

- 1) Install right side belt cover No. 2.
- 2) Install tensioner bracket.
- 3) Install left side belt cover No. 2.
- 4) Install crankshaft sprocket.
- 5) Install right side camshaft sprocket and left side camshaft sprocket. To lock camshaft use ST.

ST 499207100 CAMSHAFT SPROCKET WRENCH

CAUTION:

Do not confuse left and right side camshaft sprockets during installation. The left side camshaft sprocket is identified by a projection used to monitor cam angle sensor.

2. BELT TENSIONER AND IDLER

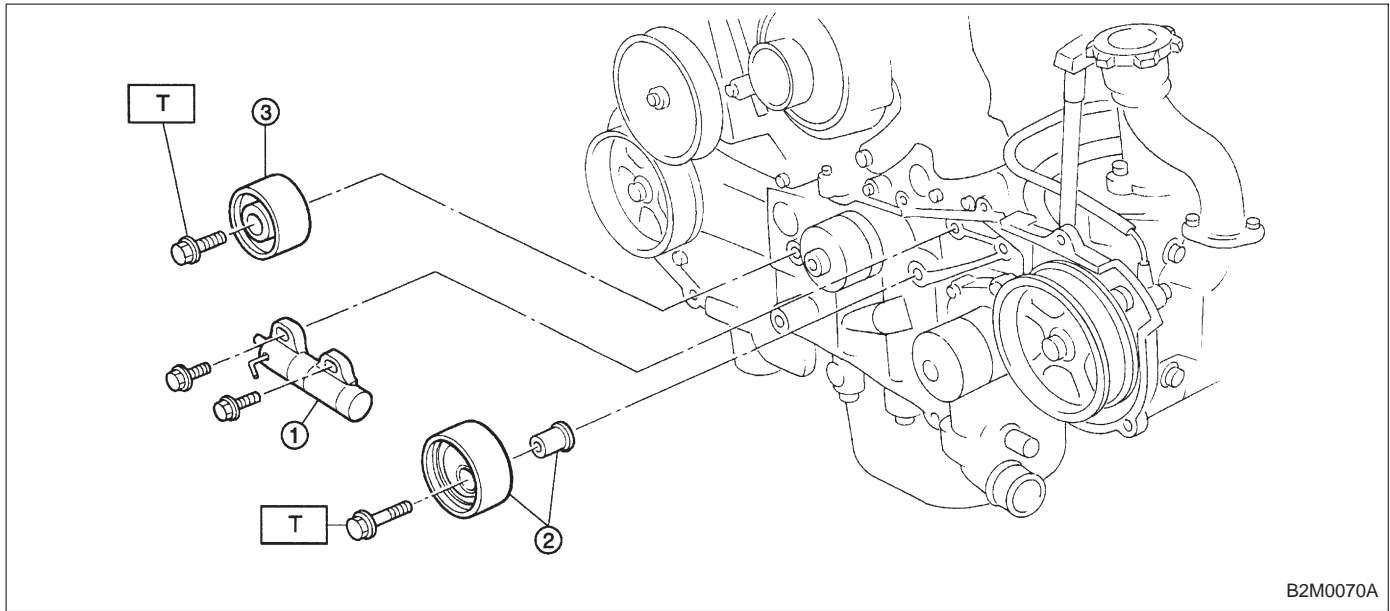

Tightening torque: N·m (kg·m, ft·lb)
T: 39±4 (4.0±0.4, 28.9±2.9)

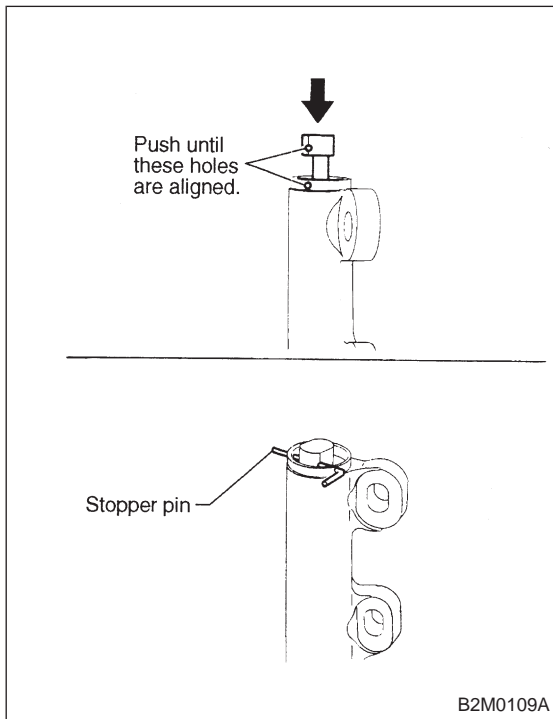

1) Installation of belt tension adjuster
Insert stopper pin 1.5 mm (0.059 in) diameter into place while pushing tension adjuster rod into body using a press.

CAUTION:

- Do not allow press pressure to exceed 9,807 N (1,000 kg, 2,205 lb).
- Do not release press pressure until stopper pin is completely inserted.
- Push tension adjuster rod vertically.
- Press-in the push rod gradually taking three minutes or more.

- 2) Install belt tensioner and spacer.
- 3) Install belt idler.

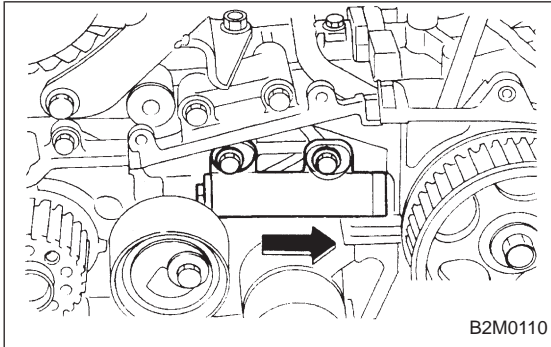

- 4) Temporarily tighten bolts while belt tension adjuster is pushed all the way to the right.

3. TIMING BELT

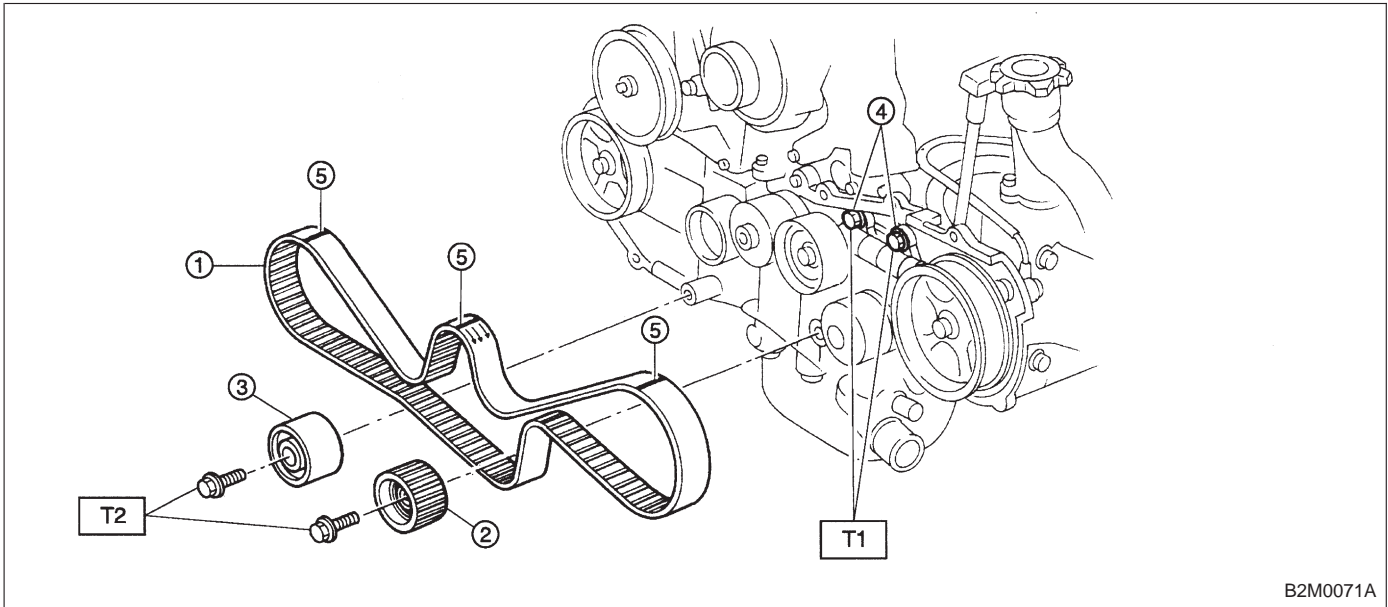

Tightening torque: N·m (kg·m, ft·lb)

T1: 25±2 (2.5±0.2, 18.1±1.4)

T2: 39±4 (4.0±0.4, 28.9±2.9)

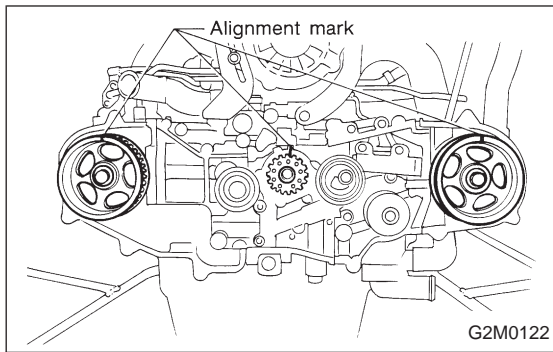

1) Installation of timing belt

(1) Using ST, turn left and right camshaft sprockets so that their alignment marks come to top positions.

ST 499207100 CAMSHAFT SPROCKET WRENCH

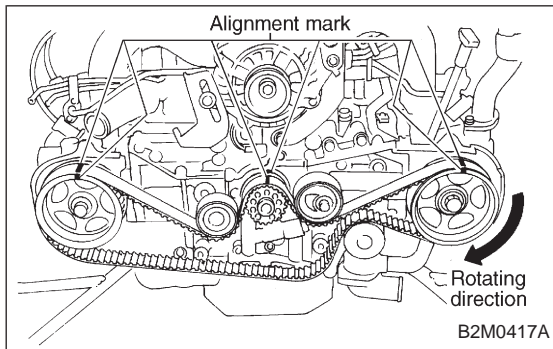

(2) While aligning alignment mark on timing belt with marks on sprockets, position timing belt properly.

CAUTION:

Ensure belt's rotating direction is correct.

2) Install belt idler No. 2.

3) Install belt idler.

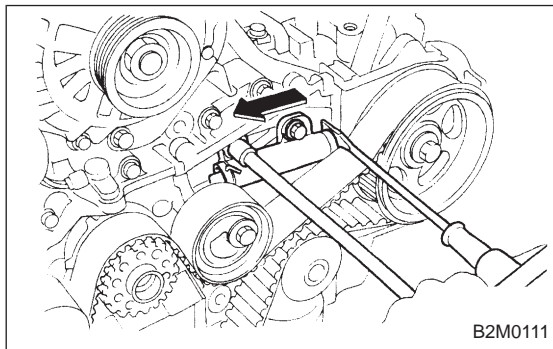

4) Loosen belt tension adjuster attaching bolts and move adjuster all the way to the left. Tighten the bolts.

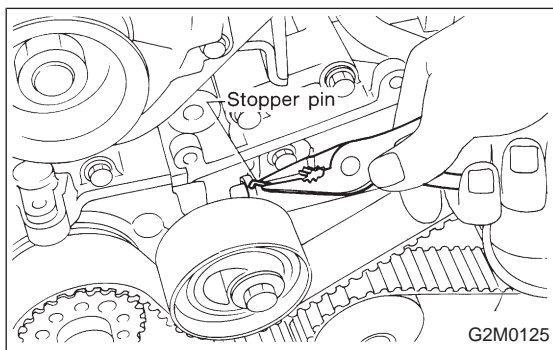

5) After ensuring that the marks on timing belt and camshaft sprockets are aligned, remove stopper pin from belt tension adjuster.

CAUTION:

After properly installing timing belt, remove rocker cover and ensure that the valve lash adjuster contains no air.

4. CRANKSHAFT PULLEY AND BELT COVER

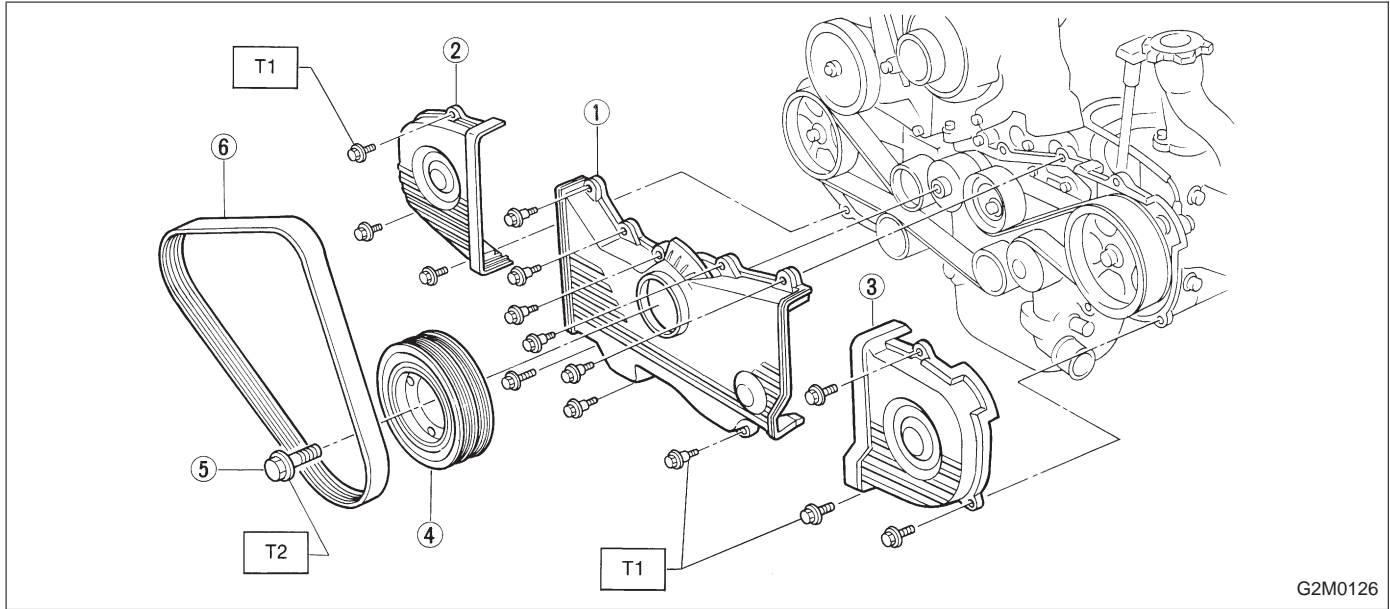

Tightening torque: N·m (kg·m, ft·lb)

T1: 5 ± 1 (0.5 ± 0.1 , 3.6 ± 0.7)

T2: 108^{+10}_{-5} ($11^{+1.0}_{-0.5}$, $79.6^{+7.2}_{-3.6}$)

- 1) Install front belt cover.
- 2) Install right side belt cover.
- 3) Install left side belt cover.
- 4) Install crankshaft pulley.

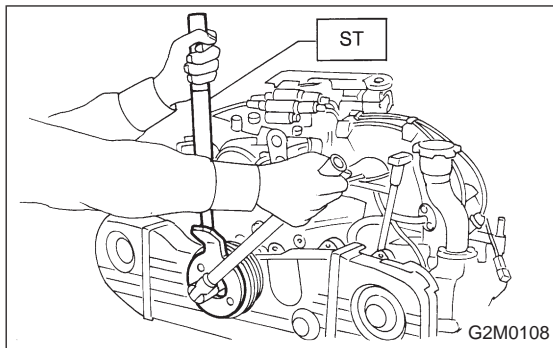

- 5) Install pulley bolt.

To lock crankshaft, use ST.

ST 499977000 CRANKSHAFT PULLEY WRENCH

- 6) Install V-belt.