

4. Valve Rocker Assembly

A: REMOVAL

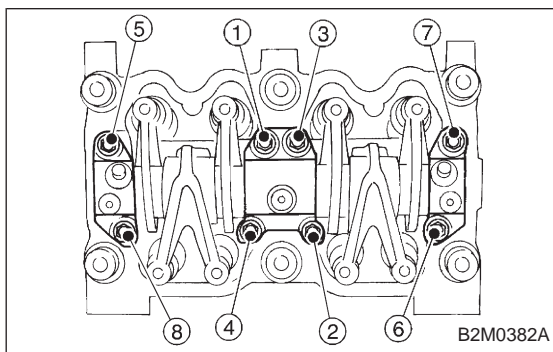
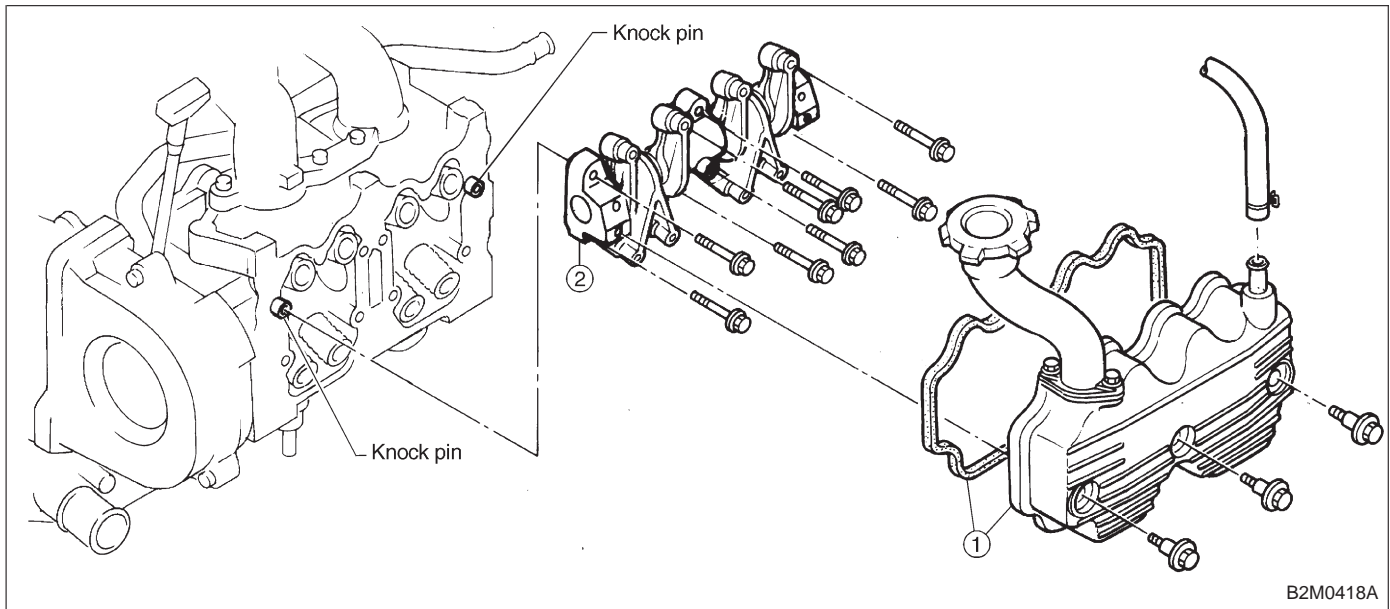

- 1) Disconnect PCV hose and remove rocker cover.
- 2) Removal of valve rocker assembly
 - (1) Remove bolts ① through ④ in numerical sequence.

CAUTION:

Leave two or three threads of bolt ① engaged to retain valve rocker assembly.

- (2) Equally loosen bolts ⑤ through ⑧ all the way, being careful that knock pin is not gouged.

- (3) Remove valve rocker assembly.

CAUTION:

Locate valve rocker assembly with air vent (on rocker arm) facing upward or dip it in engine oil after removal.

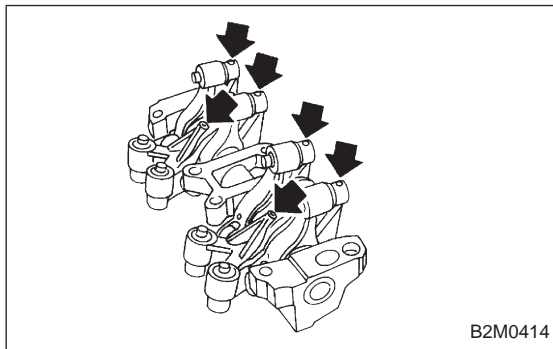

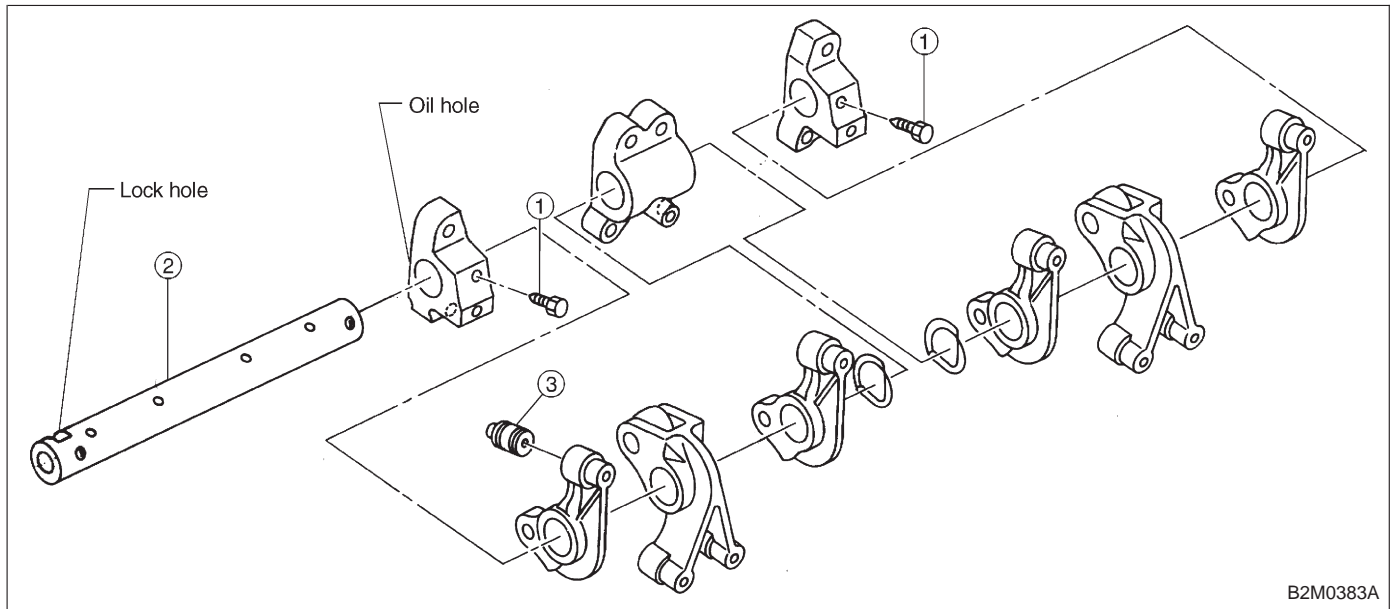
B: DISASSEMBLY

B2M0383A

- 1) Remove bolts which secure rocker shaft.
- 2) Extract rocker shaft. Remove valve rocker arms, springs and shaft supports from rocker shaft.

CAUTION:

- Arrange all removed parts in order so that they can be installed in their original positions.
- Locate rocker arms with air vents facing upward.

- 3) Remove valve lash adjuster from valve rocker.

CAUTION:

- Do not remove valve lash adjuster unless it requires air bleeding or replacement.
- If valve lash adjuster is hard to remove by hand, use pliers. Be careful not to scratch valve lash adjuster.
- Dip lash adjuster in engine oil after removal.

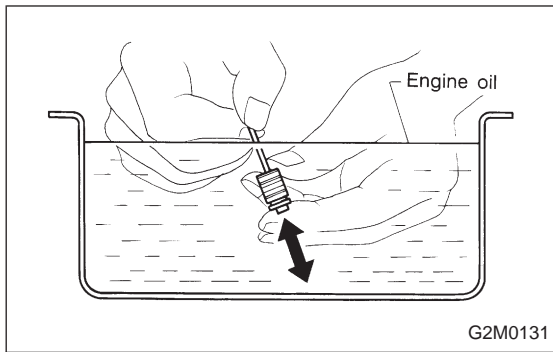

C: INSPECTION

1. HYDRAULIC LASH ADJUSTER

1) Bleed air from hydraulic lash adjuster as described below:

- (1) While dipping hydraulic lash adjuster in engine oil, as shown in Figure, push check ball in using a 2 mm (0.08 in) diameter round bar.
- (2) With check ball pushed in, manually move plunger up and down at one second intervals until air bubbles disappear.
- (3) After air bubbles disappear, remove round bar and quickly push plunger in to ensure it is locked. If plunger does not lock properly, replace hydraulic lash adjuster.

CAUTION:

Leave hydraulic lash adjuster (after air is bled) in engine oil until it is ready for installation.

2) Replace hydraulic lash adjuster with a new one if valve contact surface is scratched.

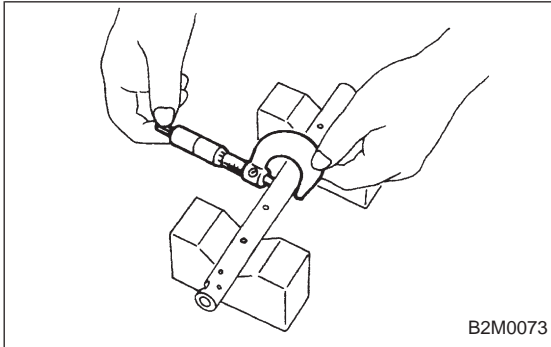
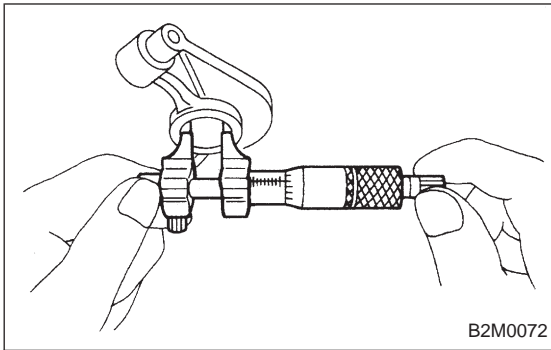

2. VALVE ROCKER ARM

1) Measure inside diameter of valve rocker arm and outside diameter of valve rocker shaft, and determine the difference between the two (= oil clearance).

Clearance between arm and shaft:

Standard

0.020 — 0.054 mm (0.0008 — 0.0021 in)

Limit

0.10 mm (0.0039 in)

If oil clearance exceeds specifications, replace valve rocker arm or shaft.

NOTE:

Replace valve rocker arm or shaft, whichever shows greater amount of wear.

Rocker arm inside diameter:

22.020 — 22.041 mm (0.8669 — 0.8678 in)

Rocker shaft diameter:

21.987 — 22.000 mm (0.8656 — 0.8661 in)

2) Measure inside diameter of rocker shaft support and outside diameter of valve rocker shaft, and determine the difference between the two (= oil clearance).

Clearance between support and shaft:

Standard

0.005 — 0.039 mm (0.0002 — 0.0015 in)

Limit

0.05 mm (0.0020 in)

If oil clearance exceeds specifications, replace rocker shaft support or shaft.

NOTE:

Replace rocker shaft support or shaft, whichever shows greater amount of wear.

Rocker shaft support inside diameter:

22.005 — 22.026 mm (0.8663 — 0.8672 in)

Rocker shaft diameter:

21.987 — 22.000 mm (0.8656 — 0.8661 in)

3) If cam or valve contact surface of valve rocker arm is worn or dented excessively, replace valve rocker arm.

4) Check that valve rocker arm roller rotates smoothly. If not, replace valve rocker arm.

3. VALVE ROCKER SHAFT

Visually check oil relief valve of shaft end for any of the following abnormalities.

- Breaks in check ball body
- Foreign particles caught in valve spring
- Oil leakage at check ball

CAUTION:

Repair or replace valve rocker shaft as necessary.

D: ASSEMBLY

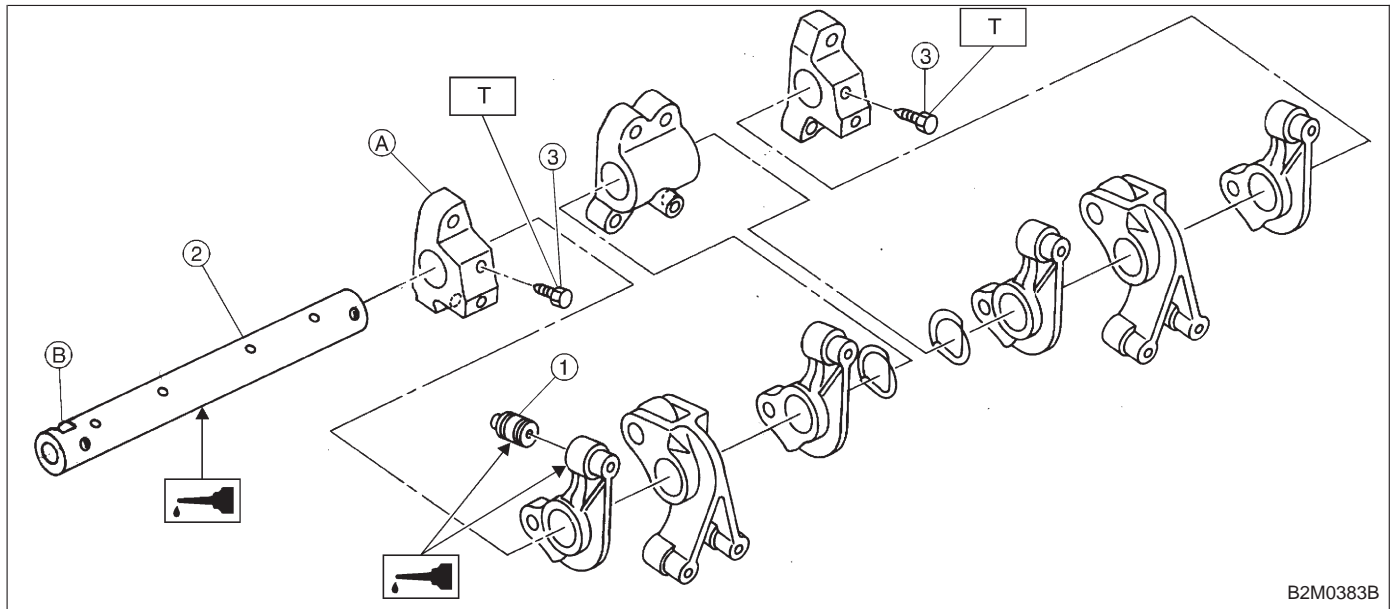

B2M0383B

Tightening torque: N·m (kg·m, ft·lb)
T: 5±1 (0.5±0.1, 3.6±0.7)

1) After bleeding air from hydraulic lash adjuster, position hydraulic lash adjuster in valve rocker arm while dipping in engine oil.

CAUTION:

- Fill rocker arm oil reservoir chamber with engine oil.
- Install a new hydraulic lash adjuster O-ring, being careful not to scratch it.
- Do not attempt to rotate hydraulic lash adjuster during installation.

2) Arrange valve rocker arms, springs and shaft supports in assembly order and insert valve rocker shaft. Ensure that cutout portion of rocker shaft faces oil holes (A) in shaft supports.

CAUTION:

Valve rocker arms, rocker shaft and shaft supports have identification marks. Ensure parts with same markings are properly assembled.

3) Install valve rocker shaft securing bolts while aligning shaft "lock" holes (B) with bolts.

E: INSTALLATION

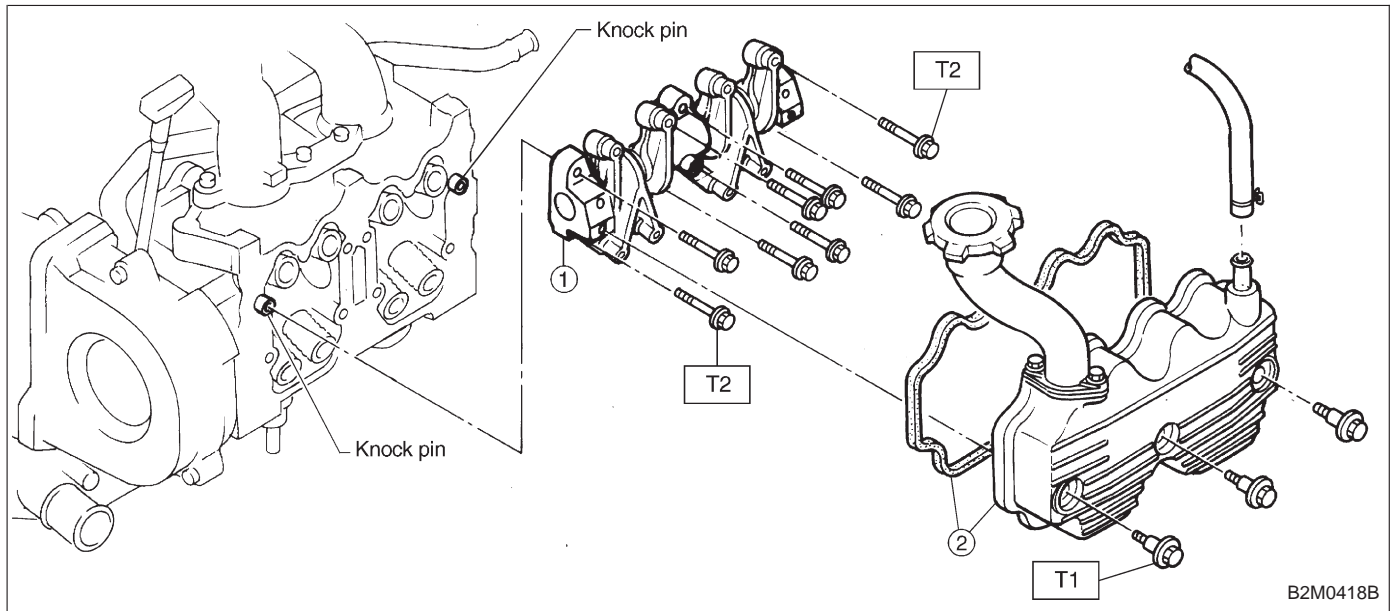

Tightening torque: N·m (kg·m, ft·lb)

T1: 5±1 (0.5±0.1, 3.6±0.7)

T2: 12±1 (1.2±0.1, 8.7±0.7)

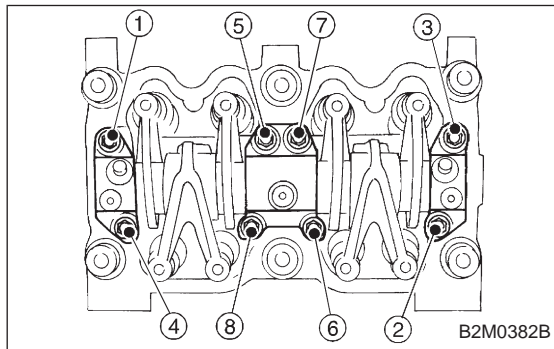

1) Installation of valve rocker assembly

(1) Temporarily tighten bolts ① through ④ equally as shown in Figure.

CAUTION:

Do not allow valve rocker assembly to gouge knock pins.

(2) Tighten bolts ⑤ through ⑧ to specified torque.

(3) Tighten bolts ① through ④ to specified torque.

2) Install rocker cover and connect PCV hose.