

2. Air Intake System

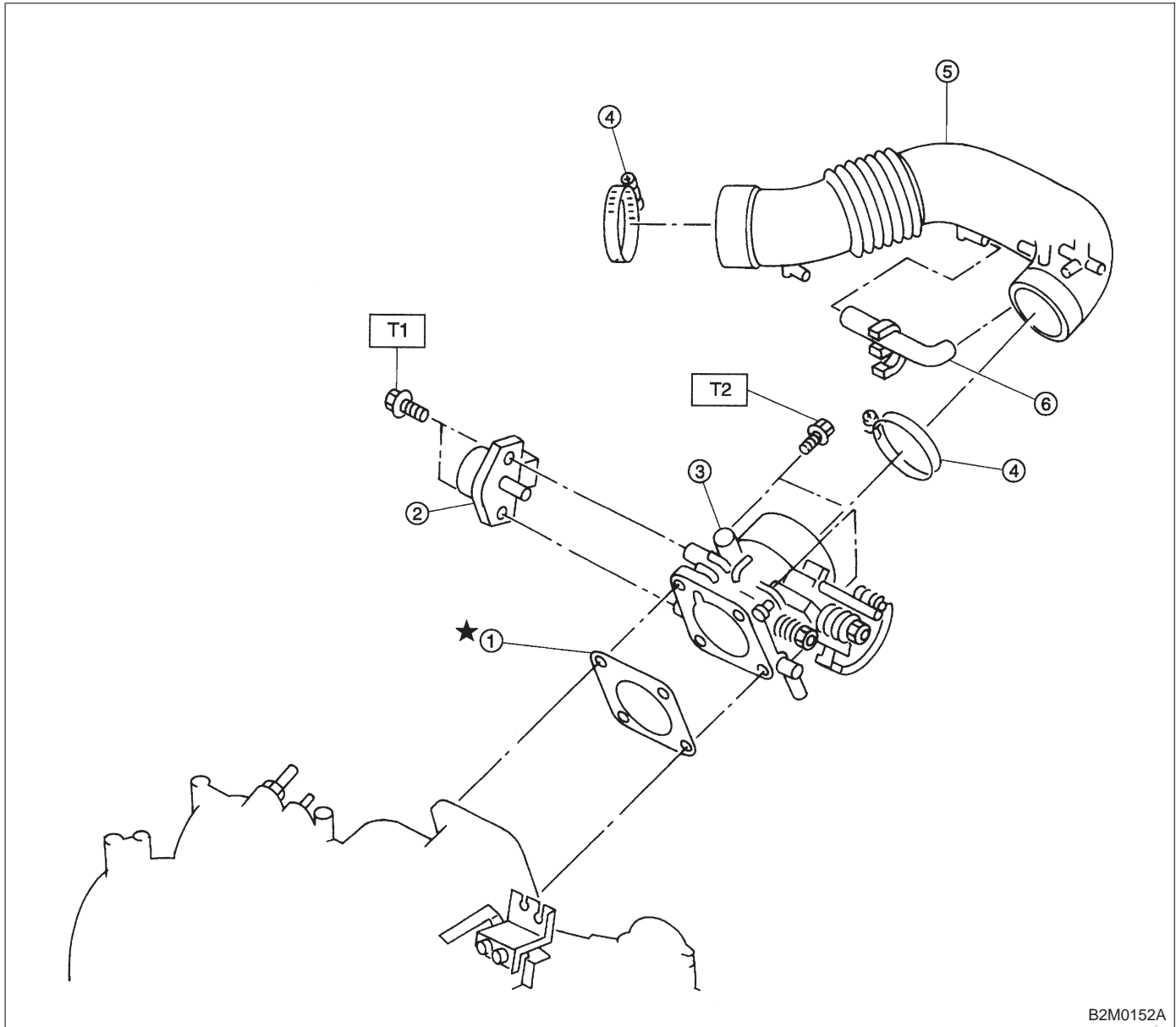

B2M0152A

- ① Gasket
- ② Throttle position sensor
- ③ Throttle body
- ④ Clamp
- ⑤ Air intake duct
- ⑥ By-pass hose

**Tightening torque: N·m (kg·m, ft·lb)**  
**T1: 2.2±0.2 (0.22±0.02, 1.6±0.1)**  
**T2: 22±2 (2.2±0.2, 15.9±1.4)**