

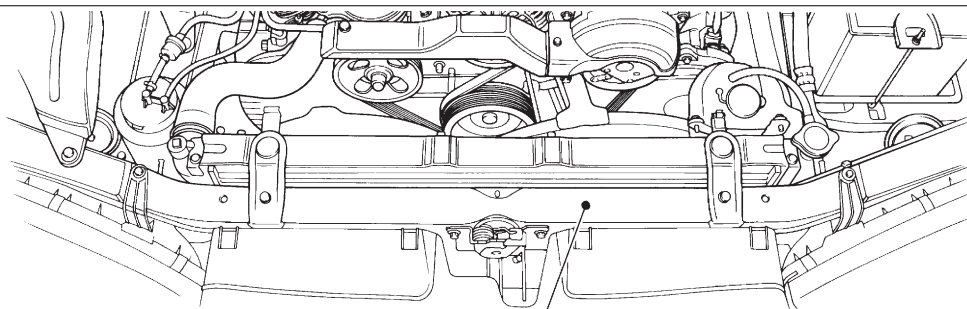

1. Safety Precautions

1. HFC-134a AIR CONDITIONING SYSTEM

Component parts of the cooling system, refrigerant, compressor oil, and other parts are not the same for the HFC-134a system and the older CFC-12 system. Do not interchange parts or liquid.

Vehicles with HFC-134a air conditioning systems, use only HFC-134a parts that are indicated on a label attached to the vehicle. Before performing any maintenance, verify the type of air conditioning system installed in the vehicle.



	SUBARU LAFAYETTE, IN		E
	AIR CONDITIONER (LI-TYPE)		
REFRIGERANT CHARGE : HFC134a 21-25 OZ (0.6-0.7kg)	REFRIGERANT UNDER HIGH PRESSURE CONSULT SERVICE MANUAL	CAUTION : USE ONLY REFRIGERANT HFC134a AND OIL ZXL200PG FOR THIS AIR CONDITIONER. DON'T USE REFRIGERANT CFC12 AND OIL D-90PX.	
COMPRESSOR OIL : ZXL200PG COMPRESSOR BELT : 73323AC000 OR 73323AC010	CAUTION : SYSTEM TO BE SERVICED BY QUALIFIED PERSONNEL SAE J639	ATTENTION : UTILISEZ LE LIQUIDE RÉFRIGÉRANT HFC134a ET L'HUILE ZXL200PG DANS CE CLIMATISEUR. NE JAMAIS UTILISER LE RÉFRIGÉRANT CFC12 ET L'HUILE D-90PX.	
		VORSICHT : NUR KÄLTEMITTEL HFC134a UND ÖL ZXL200PG FÜR DIESE KLIMAAANLAGE VERWENDEN. NIEMALS KÄLTEMITTEL CFC12 UND ÖL D-90PX.	

B4M0780

2. COMPRESSOR OIL

Do not use any compressor oil that is not specifically designated for the HFC-134a air conditioning system; only use ZXL200PG. Also, do not use HFC-134a compressor oil in the CFC-12 air conditioning system. If compression oils are mixed, poor lubrication will result and the compressor itself may be damaged.

Because HFC-134a compressor oil is very hygroscopic (easily absorbs moisture), when parts of the air conditioning system are being removed, quickly install a blind plug to prevent contact with the outside air. Also, always make sure that the service container for compressor oil is tightly closed except when in use. Store compressor oil in a tightly closed steel container.

3. REFRIGERANT

Do not put CFC-12 refrigerant into a HFC-134a air conditioning system. Also, do not put HFC-134a refrigerant into a CFC-12 air conditioning system. If the wrong refrigerant is used, poor lubrication will result and the compressor itself may be destroyed.

4. HANDLING OF REFRIGERANT

Because refrigerant boils at approx. -30°C (-22°F) at sea level, it is cold enough to give you severe frostbite. Always wear goggles to protect your eyes and gloves to protect your hands. Also, even under the pressures normally found in CFC-12 containers, refrigerant will boil with the addition of heat. This could raise the pressure inside the container to a dangerous level.

Never expose a can of HFC-134a to direct sunlight, or to temperatures over 40°C (104°F). One more thing to remember about HFC-134a is that when it is exposed to an open flame or to hot metal, it forms phosgene, a deadly gas. Do not discharge HFC-134a into the atmosphere on purpose. Always read and follow the precautions on the HFC-134a bottle.

