

- 10) After tightening axle nut, lock it securely.
- 11) Install wheel and tighten wheel nuts to specified torque.

Tightening torque:

88 ± 10 N·m (9 ± 1 kg·m, 65 ± 7 ft·lb)

2. Rear Axle (AWD Model)

A: REMOVAL

- 1) Disconnect ground cable from battery.
- 2) Jack-up vehicle, and remove rear wheel cap and wheels.

CAUTION:

Be sure to loosen and retighten axle nut after removing wheel from vehicle. Failure to follow this rule may damage wheel bearings.

- 3) Unlock axle nut.
- 4) Remove axle nut using a socket wrench.

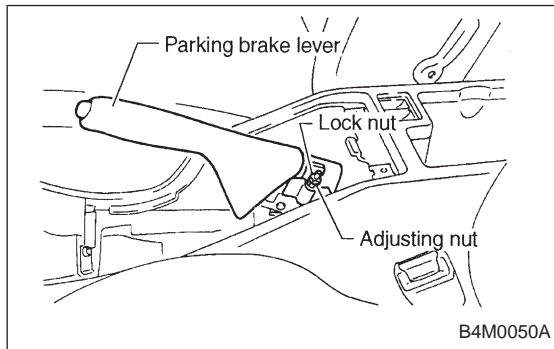

- 5) Return parking brake lever and loosen adjusting nut.
 - (1) Disc brake: Perform steps 6) and 7).
 - (2) Drum brake: Perform steps 8) through 10).

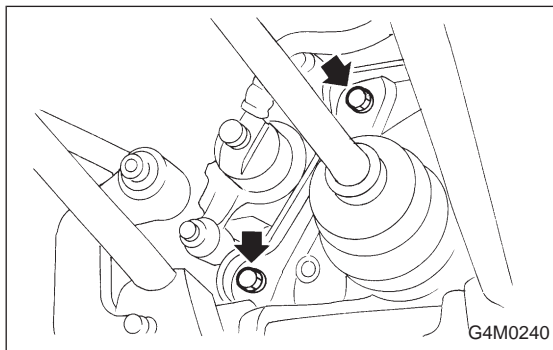

- 6) Remove disc brake caliper from back plate, and suspend it from strut using a piece of wire.
- 7) Remove disc rotor from hub.

NOTE:

If disc rotor seizes up within hub, drive it out by installing an 8-mm bolt into bolt hole in disc rotor.

8) Remove brake drum from hub.

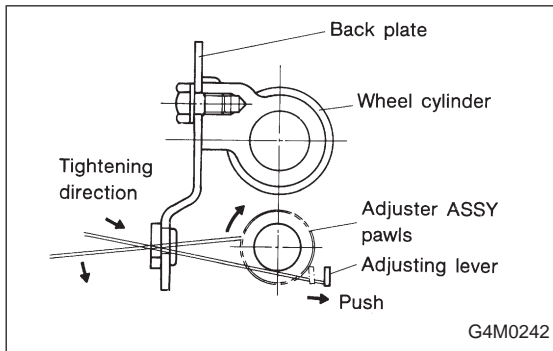

9) If it is difficult to remove brake drum, remove adjusting hole cover from back plate, and then turn adjusting screw using a slot-type screwdriver until brake shoe separates from the drum.

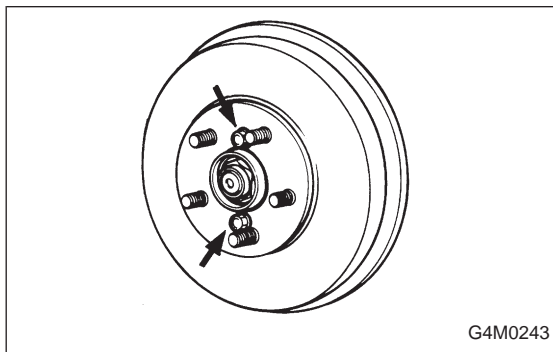

NOTE:

If brake drum is difficult to remove, drive it out by installing an 8-mm bolt into bolt hole in brake drum.

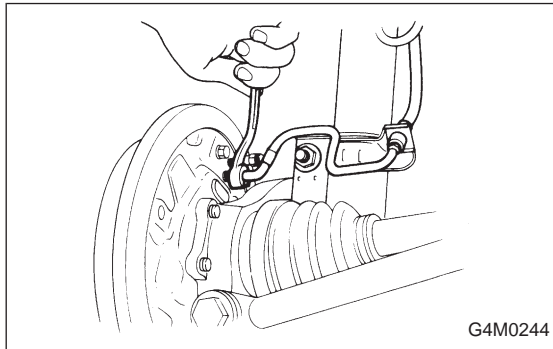

10) Using a flare-nut wrench, disconnect brake pipe from wheel cylinder.

CAUTION:

Cover open end of wheel cylinder to prevent entry of foreign particles.

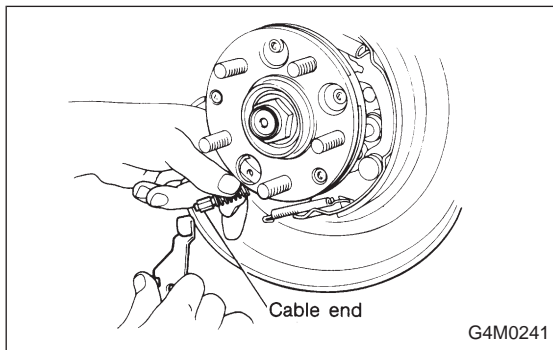

11) Disconnect parking brake cable end.

2. Rear Axle (AWD Model)

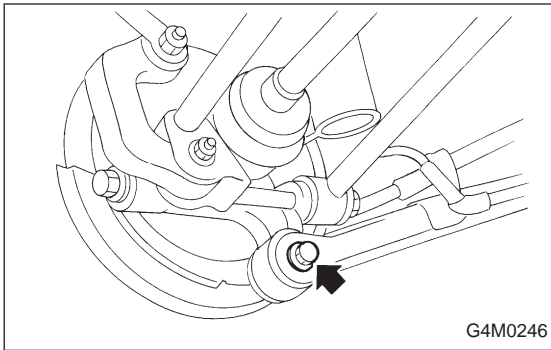

12) Remove bolts which secure trailing link assembly to rear housing.

CAUTION:

Discard old self-locking nut. Replace with a new one.

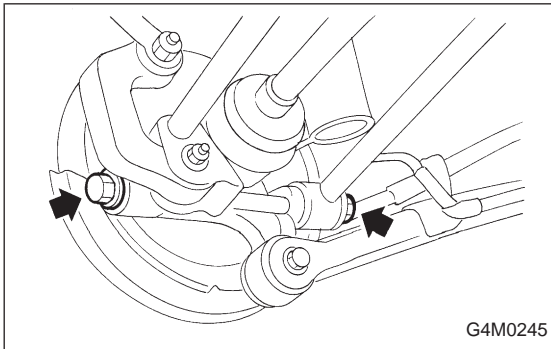

13) Remove bolts which secure lateral link assembly to rear housing.

CAUTION:

Discard old self-locking nut. Replace with a new one.

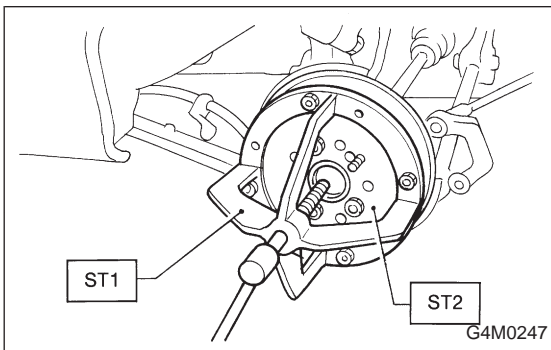

14) Disengage BJ from housing splines, and remove rear drive shaft assembly. If it is hard to remove, use STs.

ST1 926470000 AXLE SHAFT PULLER

ST2 927140000 PLATE

CAUTION:

- Be careful not to damage oil seal lip when removing rear drive shaft.

- When rear drive shaft is to be replaced, also replace inner oil seal with a new one.

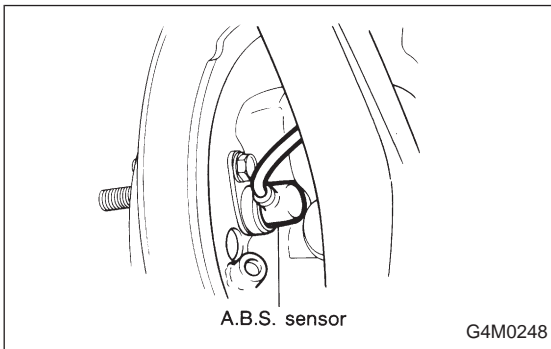

15) Remove rear A.B.S. sensor from back plate (only vehicle equipped with A.B.S.).

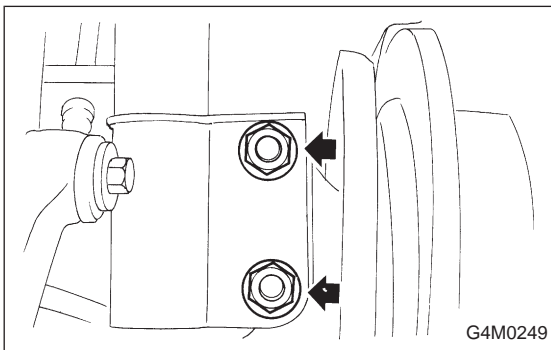

16) Remove bolts which secure rear housing to strut, and separate the two.

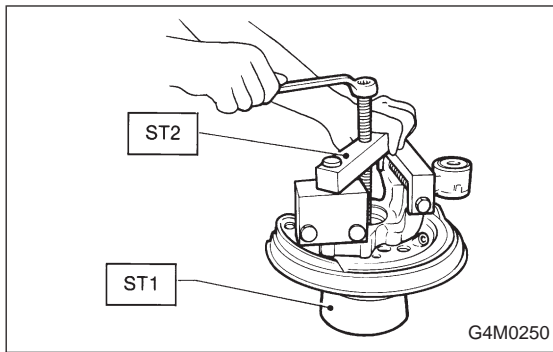

B: DISASSEMBLY

- 1) Using ST1 and ST2, remove hub from rear housing.
 ST1 927080000 HUB STAND
 ST2 927420000 HUB REMOVER
- 2) Remove back plate from rear housing.
- 3) Using a standard screwdriver, remove outer and inner oil seals.

CAUTION:
 Use new oil seals.

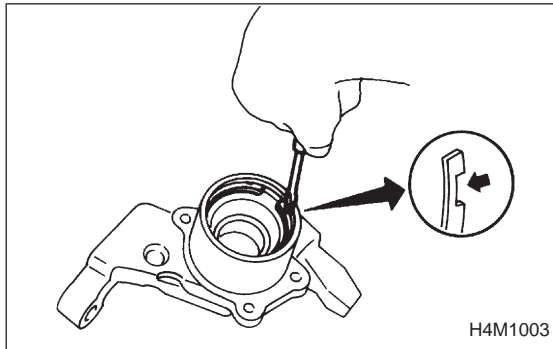

- 4) Using flat bladed screwdriver, remove snap ring.

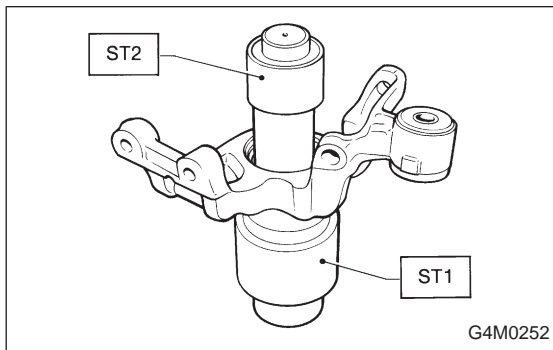

- 5) Using ST1 and ST2, remove bearing by pressing inner race.
 ST1 927430000 HOUSING STAND
 ST2 927440000 BEARING REMOVER

CAUTION:

- Do not remove bearing unless damaged.
- Do not re-use bearing after removal.

- 6) Remove tone wheel bolts and remove tone wheel from hub (only vehicle equipped with A.B.S.).

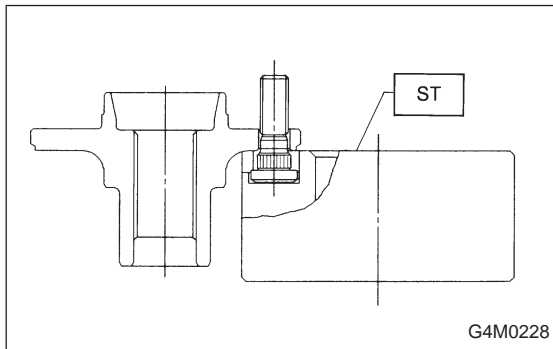

- 7) Using ST, press hub bolts out.
 ST 927080000 HUB STAND

CAUTION:
 Be careful not to hammer hub bolts. This may deform hub.

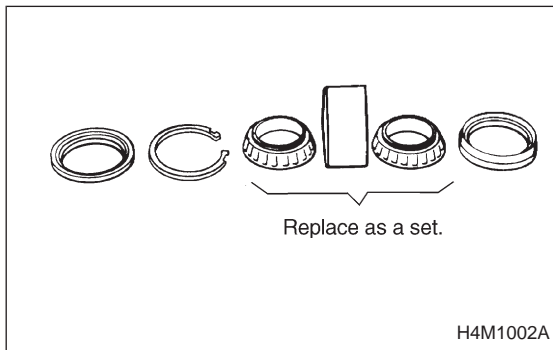

C: INSPECTION

Check the removed parts for wear and damage. If defective, replace with new ones.

CAUTION:

- If a bearing is faulty, replace it as a bearing set.
- Be sure to replace oil seal at every overhaul.

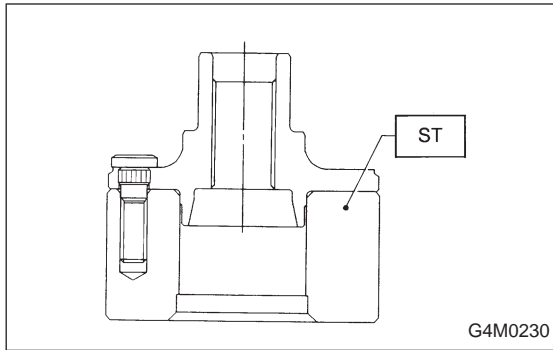
**D: ASSEMBLY**

1) Using ST, press new hub bolt into place.

CAUTION:

- Ensure hub bolt closely contacts hub.
- Use a 12 mm (0.47 in) hole in the ST to prevent hub bolt from tilting during installation.

ST 927080000 HUB STAND

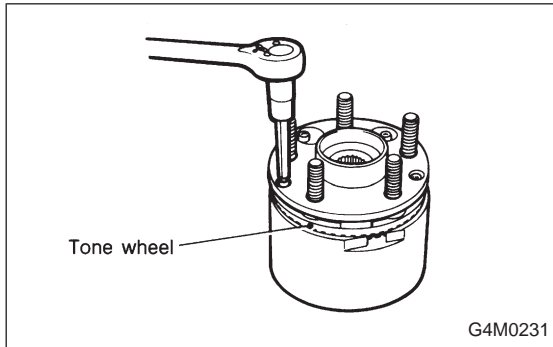

2) Remove foreign particles (dust, rust, etc.) from mating surfaces of hub and tone wheel, and install tone wheel to hub (only vehicle equipped with A.B.S.).

CAUTION:

- Ensure tone wheel closely contacts hub.
- Be careful not to damage tone wheel teeth.

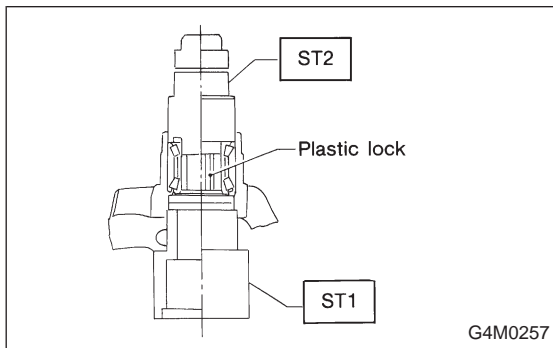

3) Clean housing interior completely. Using ST1 and ST2, press bearing into housing.

ST1 927430000 HOUSING STAND

ST2 927440000 BEARING REMOVER

CAUTION:

- Always press outer race when installing bearing.
- Be careful not to remove plastic lock from inner race when installing bearing.
- Charge bearing with new grease when outer race is not removed.

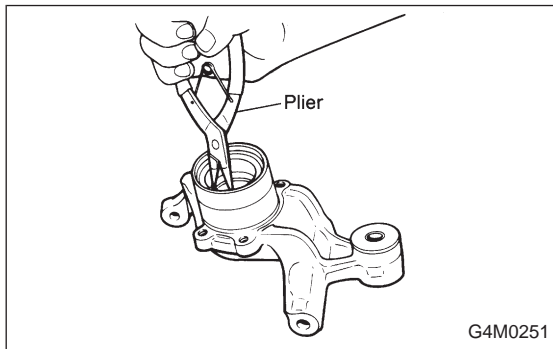

4) Install snap ring.

CAUTION:

Ensure snap ring fits in groove properly.

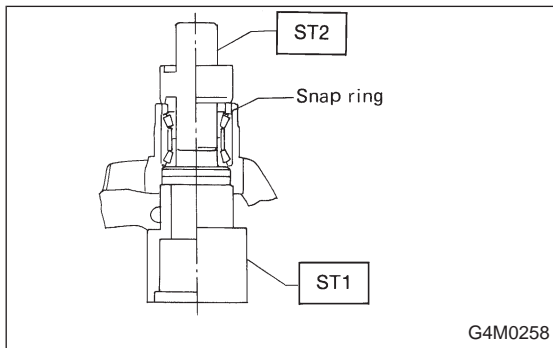

5) Using ST1 and ST2, press outer oil seal until it comes in contact with snap ring.

ST1 927430000 HOUSING STAND

ST2 927460000 OIL SEAL INSTALLER

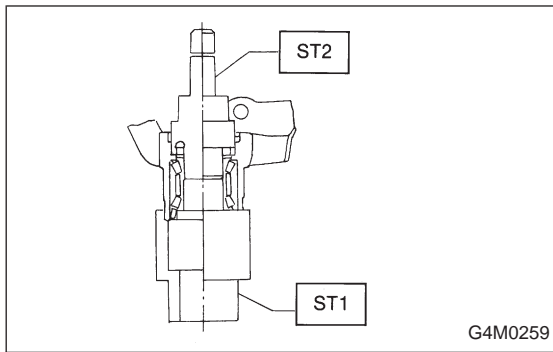

- 6) Invert both ST1 and housing.
- 7) Using ST2, press inner oil seal into housing until it touches bottom.

ST1 927430000 HOUSING STAND
 ST2 927460000 OIL SEAL INSTALLER

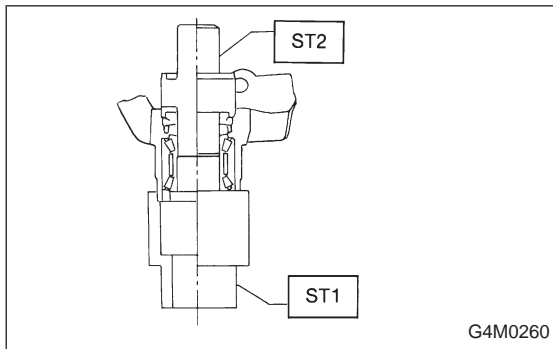

- 8) Using ST1 and ST2, press sub seal into place.

ST1 927430000 HOUSING STAND
 ST2 927460000 OIL SEAL INSTALLER

- 9) Apply sufficient grease to oil seal lip.

Specified grease:
SHELL 6459N

CAUTION:

- If specified grease is not available, remove bearing grease and apply Auto Rex A instead.
- Do not mix different types of grease.

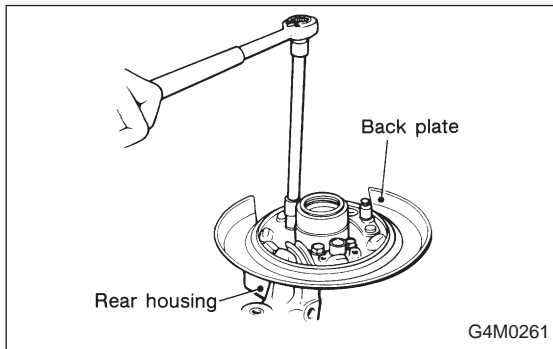

- 10) Install back plate to rear housing.

Tightening torque:
52±6 N·m (5.3±0.6 kg·m, 38.3±4.3 ft·lb)

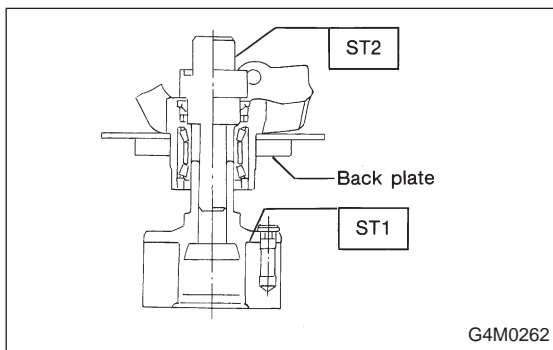

- 11) Using ST1 and ST2, press bearing into hub.

ST1 927080000 HUB STAND
 ST2 927450000 HUB INSTALLER

E: INSTALLATION

1) Connect rear housing assembly and strut assembly.

CAUTION:

Use a new self-locking nut.

Tightening torque:

$147 \pm 15 \text{ N}\cdot\text{m}$ ($15 \pm 1.5 \text{ kg}\cdot\text{m}$, $108 \pm 11 \text{ ft}\cdot\text{lb}$)

2) Fit BJ (bell joint) to rear housing splines.

CAUTION:

Be careful not to damage inner oil seal lip.

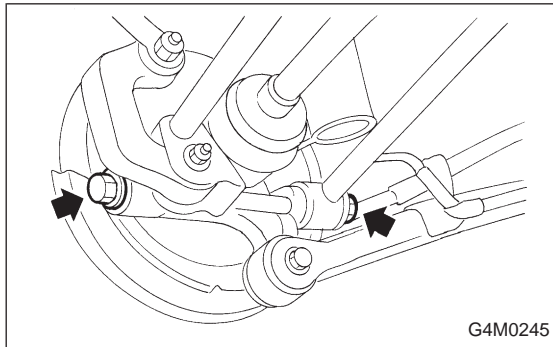

G4M0245

3) Connect rear housing assembly to lateral link assembly.

CAUTION:

Use a new self-locking nut.

Tightening torque:

$137 \pm 20 \text{ N}\cdot\text{m}$ ($14 \pm 2 \text{ kg}\cdot\text{m}$, $101 \pm 14 \text{ ft}\cdot\text{lb}$)

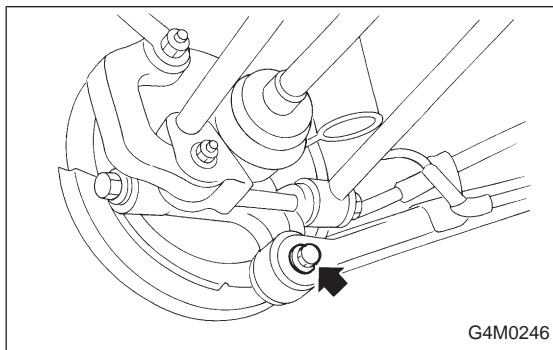

G4M0246

4) Connect rear housing assembly to trailing link assembly.

CAUTION:

Use a new self-locking nut.

Tightening torque:

$98 - 127 \text{ N}\cdot\text{m}$ ($10 - 13 \text{ kg}\cdot\text{m}$, $72 - 94 \text{ ft}\cdot\text{lb}$)

5) Connect parking brake cable to parking brake.

Disc brake: Perform steps 6) through 8).

6) Install disc rotor on rear housing assembly.

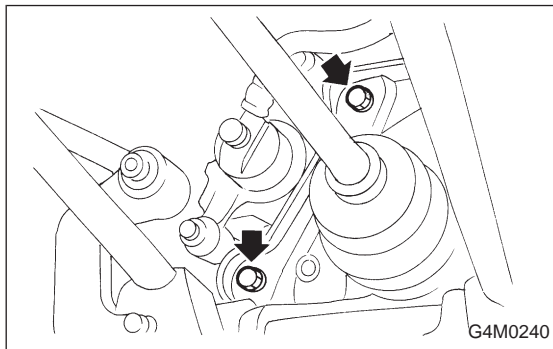

G4M0240

7) Install disc brake caliper on back plate.

Tightening torque:

$52 \pm 6 \text{ N}\cdot\text{m}$ ($5.3 \pm 0.6 \text{ kg}\cdot\text{m}$, $38.3 \pm 4.3 \text{ ft}\cdot\text{lb}$)

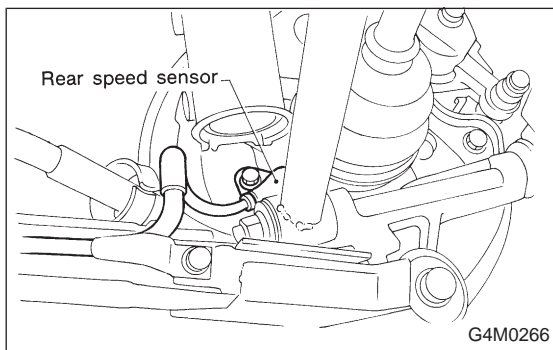

G4M0266

8) Install rear speed sensor to back plate (only vehicle equipped with A.B.S.).

Drum brake: Perform steps 9) through 11).

9) Clean brake pipe connection. Using a flare-nut wrench, connect brake pipe to wheel cylinder.

10) Connect parking brake cable to lever.

11) Install brake drum on rear housing assembly.

12) Bleed air from brake system. <Ref. to 4-4 [W11B0].>

13) Adjust parking brake lever stroke by turning adjuster.

14) Move brake lever back to apply brakes. While depressing brake pedal, tighten axle nut using a socket wrench. Lock axle nut after tightening.

Tightening torque:

186±20 N·m (19±2 kg-m, 137±14 ft-lb)

CAUTION:

- Use a new axle nut.
- Always tighten axle nut before installing wheel on vehicle. If wheel is installed and comes in contact with ground when axle nut is loose, wheel bearings may be damaged.
- Be sure to tighten axle nut to specified torque. Do not overtighten it as this may damage wheel bearing.

15) Install wheel and tighten wheel nuts to specified torque.

15) Install wheel and tighten wheel nuts to specified torque.

Tightening torque:

88±10 N·m (9±1 kg-m, 65±7 ft-lb)

3. Rear Axle (FWD Model)

A: REMOVAL

1) Disconnect ground cable from battery.

2) Jack-up vehicle, and remove rear wheel cap and wheels.

CAUTION:

Be sure to loosen and retighten axle nut after removing wheel from vehicle. Failure to follow this rule may damage wheel bearings.

3) Pry hub cap off with a screwdriver placed between it and hub.

4) Unlock axle nut.

5) Remove axle nut using a socket wrench. Remove washer.

CAUTION:

Do not re-use old axle nut. Replace with a new one.

NOTE:

Temporarily tighten axle nut to hold hub in place.