

7) Coat the seal ring with vaseline, and install it in the seal ring groove of the shaft.

CAUTION:

Do not expand the seal ring excessively when installing.

ST 899580100 INSTALLER

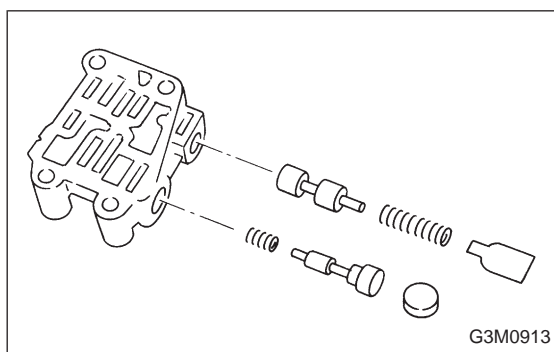

16. Transfer Valve Body

A: DISASSEMBLY

1) Remove the plate. Then remove the spring and pilot valve together.

2) Remove the straight pin and pry out the plug with a screwdriver. Then extract the spring and transfer clutch valve together.

CAUTION:

Be careful not to damage the valve and valve body.

B: INSPECTION

Check each component for harmful cuts, damage, or other faults.

C: ASSEMBLY

To assemble, reverse the removal sequence.

NOTE:

Make sure the valve slides smoothly after assembling.