

## 6-2b [T6A0] BODY ELECTRICAL SYSTEM (ELECTRICAL PARTS)

### 6. Security System

## 6. Security System

### A: ELECTRICAL COMPONENTS LOCATION

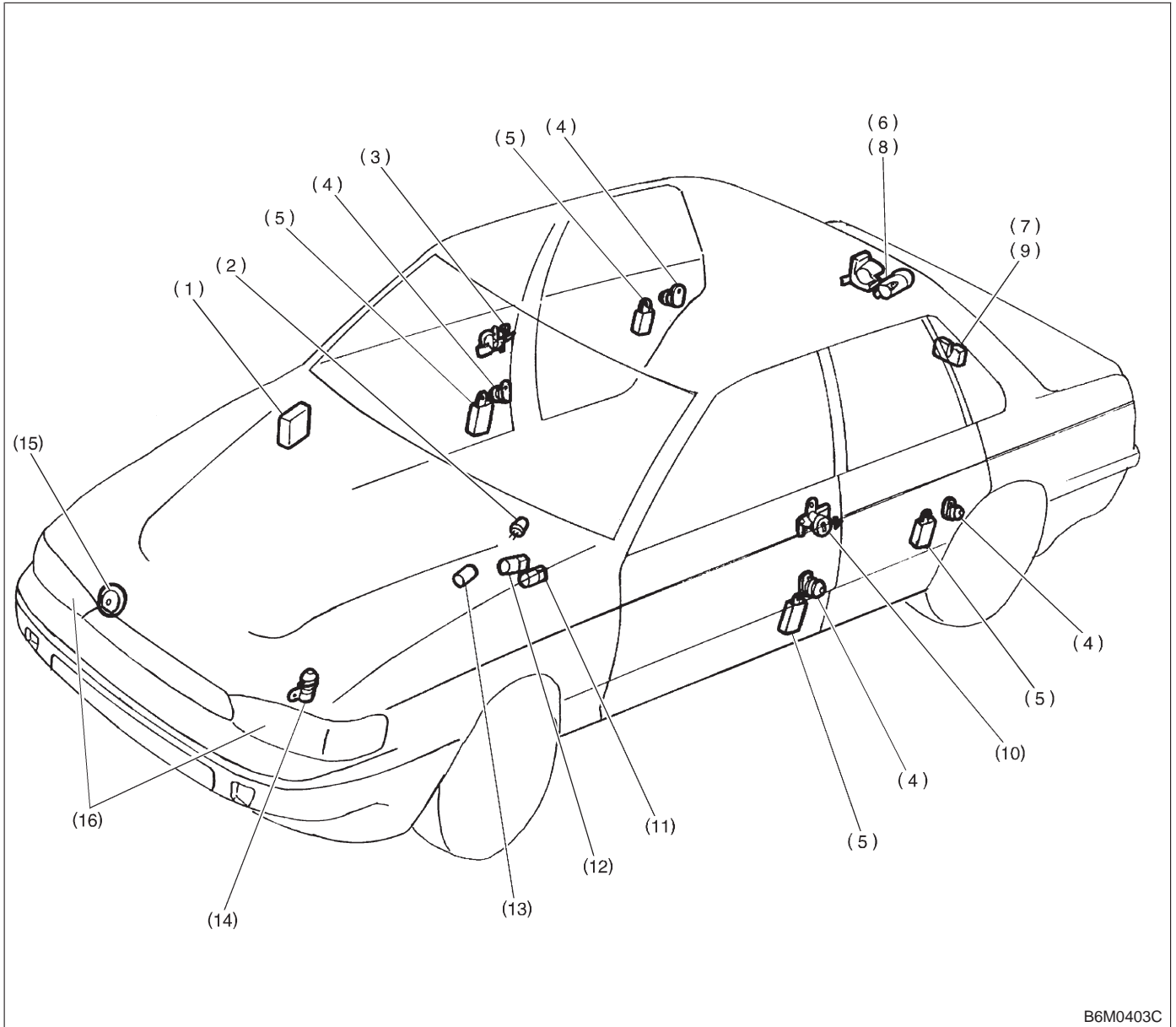

B6M0403C

- |   |  |                         |
|---|--|-------------------------|
| (1) Security control module   | (7) Trunk lid switch (SEDAN)   | (14) Engine hood switch |
| (2) Security indicator light  | (8) Rear gate key cylinder lock/<br>unlock switch (WAGON)                | (15) Horn               |
| (3) RH door key cylinder lock/unlock<br>switch (built-in tamper switch)         | (9) Rear gate switch (WAGON)   | (16) Headlight          |
| (4) Door switch   | (10) LH door key cylinder lock/unlock<br>switch (built-in tamper switch) |                         |
| (5) Door lock/unlock switch   | (11) Starter interrupt relay   |                         |
| (6) Trunk lid key cylinder unlock<br>switch (SEDAN) (built-in tamper<br>switch) | (12) Headlight alarm relay   |                         |
|   | (13) Ignition switch (ACC position)                                      |                         |

**B: SCHEMATIC**

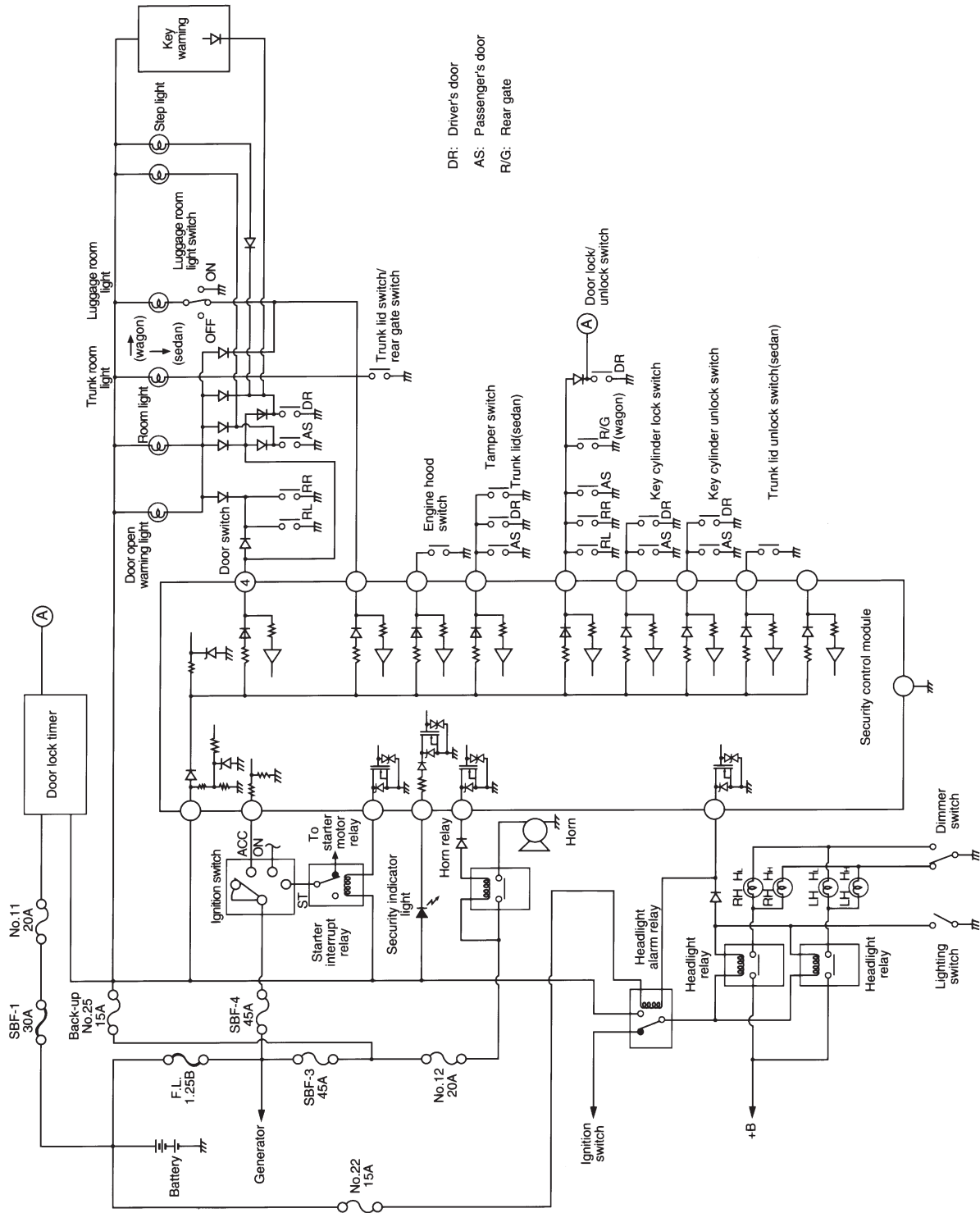

B6H0319

## 6-2b [T6C0] BODY ELECTRICAL SYSTEM (ELECTRICAL PARTS)

### 6. Security System

#### C: CONTROL MODULE I/O SIGNAL

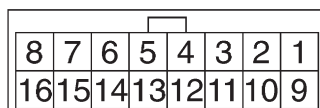

B6M0405

Content	Terminal No.	Measuring conditions and I/O signals (Ignition switch ACC position)
Door lock/unlock switch	1 (INPUT)	<ul style="list-style-type: none"> <li>Battery voltage is present when all doors and rear gate (WAGON) are locked.</li> <li>"0" volt is present when one of the doors or rear gate (WAGON) is unlocked.</li> </ul>
Key cylinder lock switch	2 (INPUT)	<ul style="list-style-type: none"> <li>"0" volt is present when key cylinder is turned to LOCK position.</li> <li>Battery voltage is present when key cylinder is in positions other than LOCK.</li> </ul>
Tamper switch	3 (INPUT)	<ul style="list-style-type: none"> <li>Battery voltage is present when key cylinder switch is installed to key cylinder.</li> <li>"0" volt is present when key cylinder switch is removed from key cylinder.</li> </ul>
Door switch	4 (INPUT)	<ul style="list-style-type: none"> <li>Battery voltage is present when all doors are closed.</li> <li>"0" volt is present when one of the door is open.</li> </ul>
Starter interrupt relay	5 (OUTPUT)	<ul style="list-style-type: none"> <li>Battery voltage is present when ignition switch is turned ACC or ON.</li> <li>"0" volt is present when security system is in alarm state.</li> </ul>
Ignition switch (ACC)	6 (INPUT)	<ul style="list-style-type: none"> <li>Battery voltage is present when ignition switch is turned ACC or ON.</li> <li>"0" volt is present when ignition switch is turned OFF.</li> </ul>
Security indicator light	7 (OUTPUT)	<ul style="list-style-type: none"> <li>Battery voltage is present when indicator light goes off.</li> <li>"0" volt is present when indicator light illuminates.</li> </ul>
Power supply (back-up)	8	Battery voltage is constantly present.
Ground	9	—
Engine hood switch	10 (INPUT)	<ul style="list-style-type: none"> <li>Battery voltage is present when engine hood is closed.</li> <li>"0" volt is present when engine hood is open.</li> </ul>
Trunk lid switch (SEDAN) Rear gate switch (WAGON)	11 (INPUT)	<ul style="list-style-type: none"> <li>Battery voltage is present when trunk lid or rear gate is closed.</li> <li>"0" volt is present when trunk lid or rear gate is open.</li> </ul>
Headlight alarm relay	12 (OUTPUT)	<ul style="list-style-type: none"> <li>Battery voltage is present when ignition switch is turned ACC or ON.</li> <li>"0" volt and battery voltage repeats in alarm state. (Headlights flash intermittently at 0.2 sec. ON and 0.6 sec. OFF intervals).</li> </ul>
Horn relay	13 (OUTPUT)	<ul style="list-style-type: none"> <li>Battery voltage is present when ignition switch is turned ACC or ON.</li> <li>"0" volt and battery voltage repeats in alarm state. (Horn sounds intermittently at 0.2 sec. ON and 0.6 sec. OFF intervals.)</li> </ul>
Key cylinder unlock switch	14 (INPUT)	<ul style="list-style-type: none"> <li>"0" volt is present when key cylinder is turned to UNLOCK position.</li> <li>Battery voltage is present when key cylinder is in positions other than UNLOCK.</li> </ul>
Trunk lid key cylinder unlock switch (SEDAN)	15 (INPUT)	<ul style="list-style-type: none"> <li>"0" volt is present when trunk lid key cylinder is turned to UNLOCK position.</li> <li>Battery voltage is present when trunk lid key cylinder is in positions other than UNLOCK.</li> </ul>

**D: BASIC DIAGNOSTICS PROCEDURE**

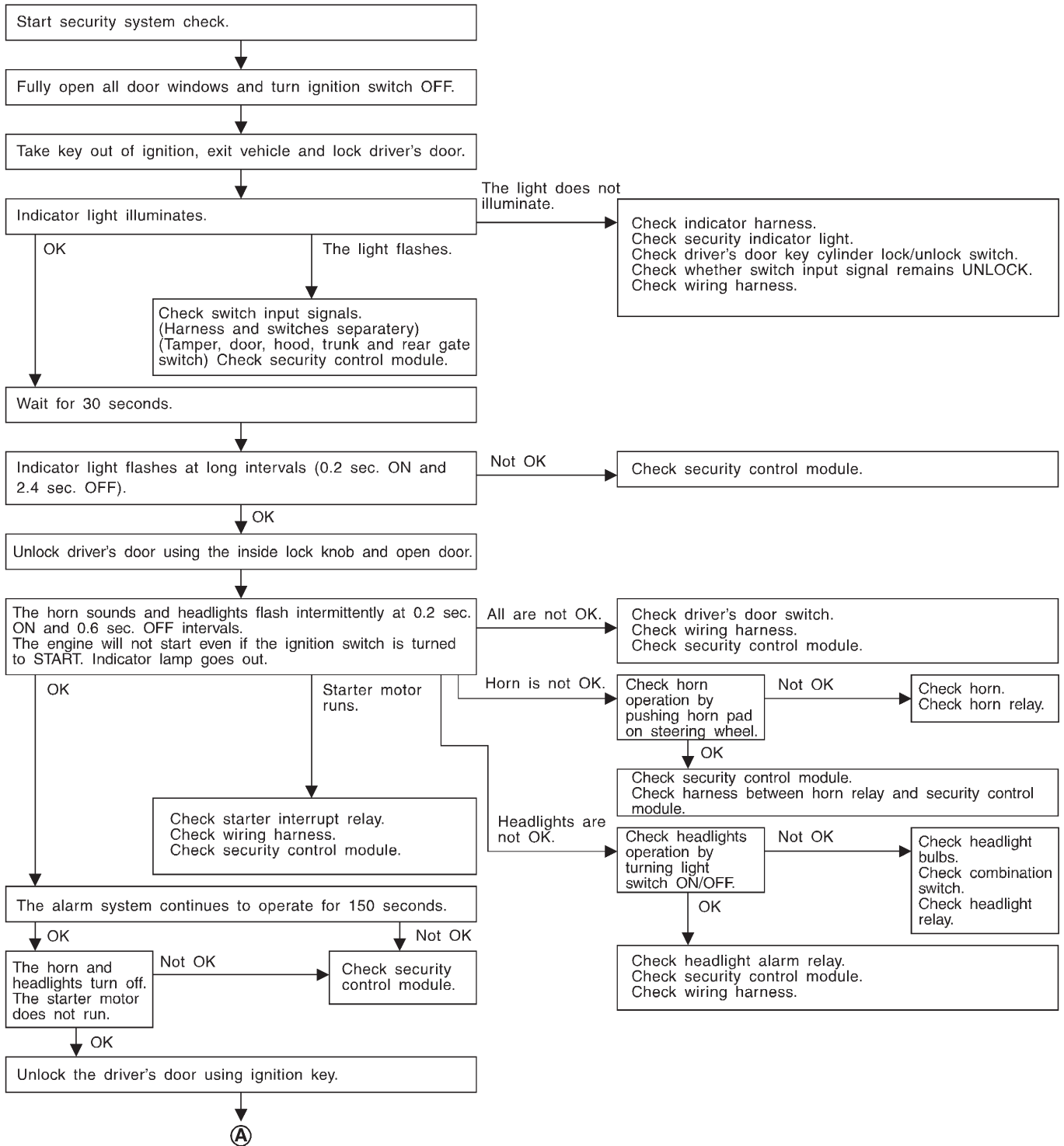

# 6-2b [T6D0] BODY ELECTRICAL SYSTEM (ELECTRICAL PARTS)

## 6. Security System

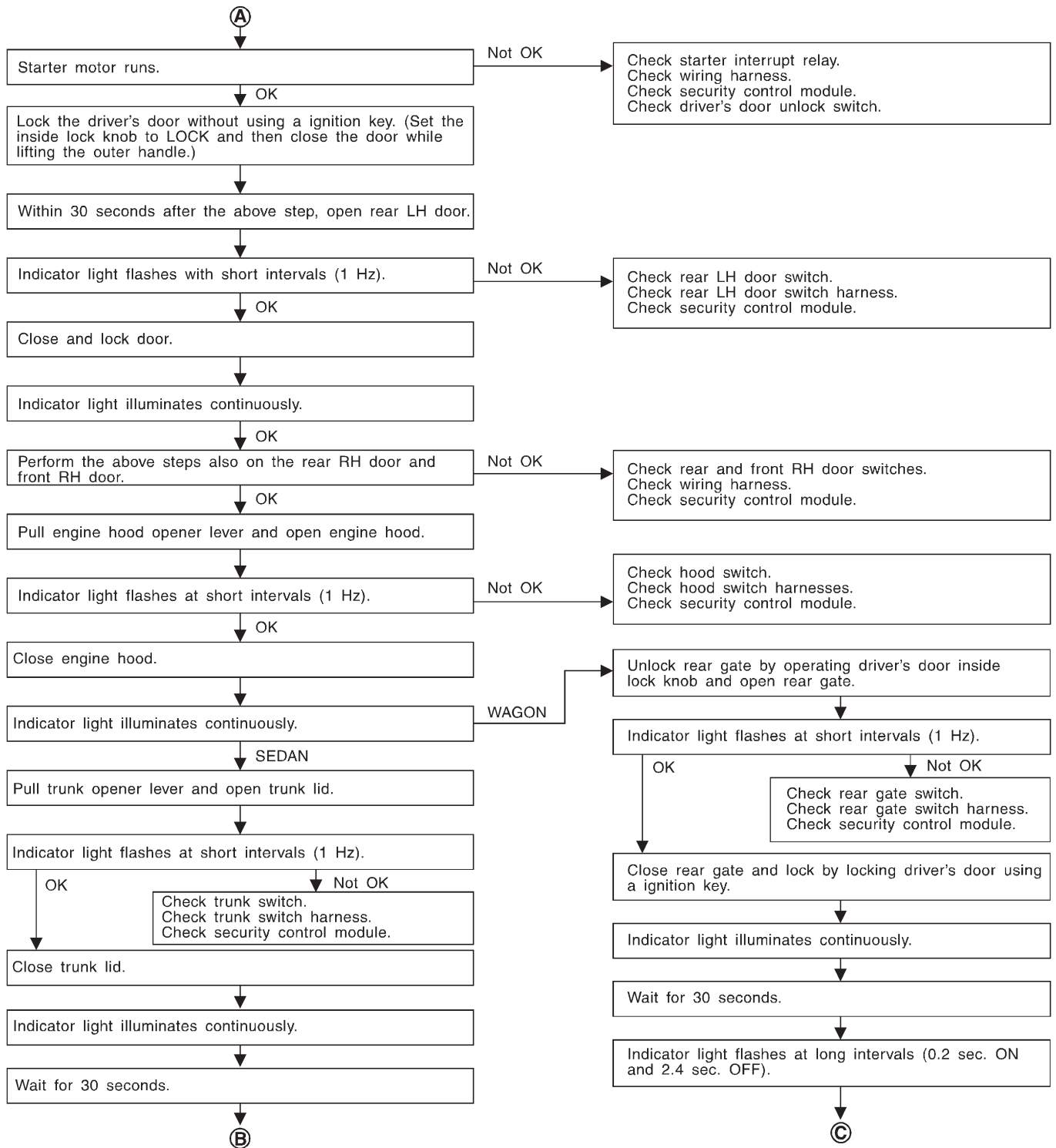

B6M0735

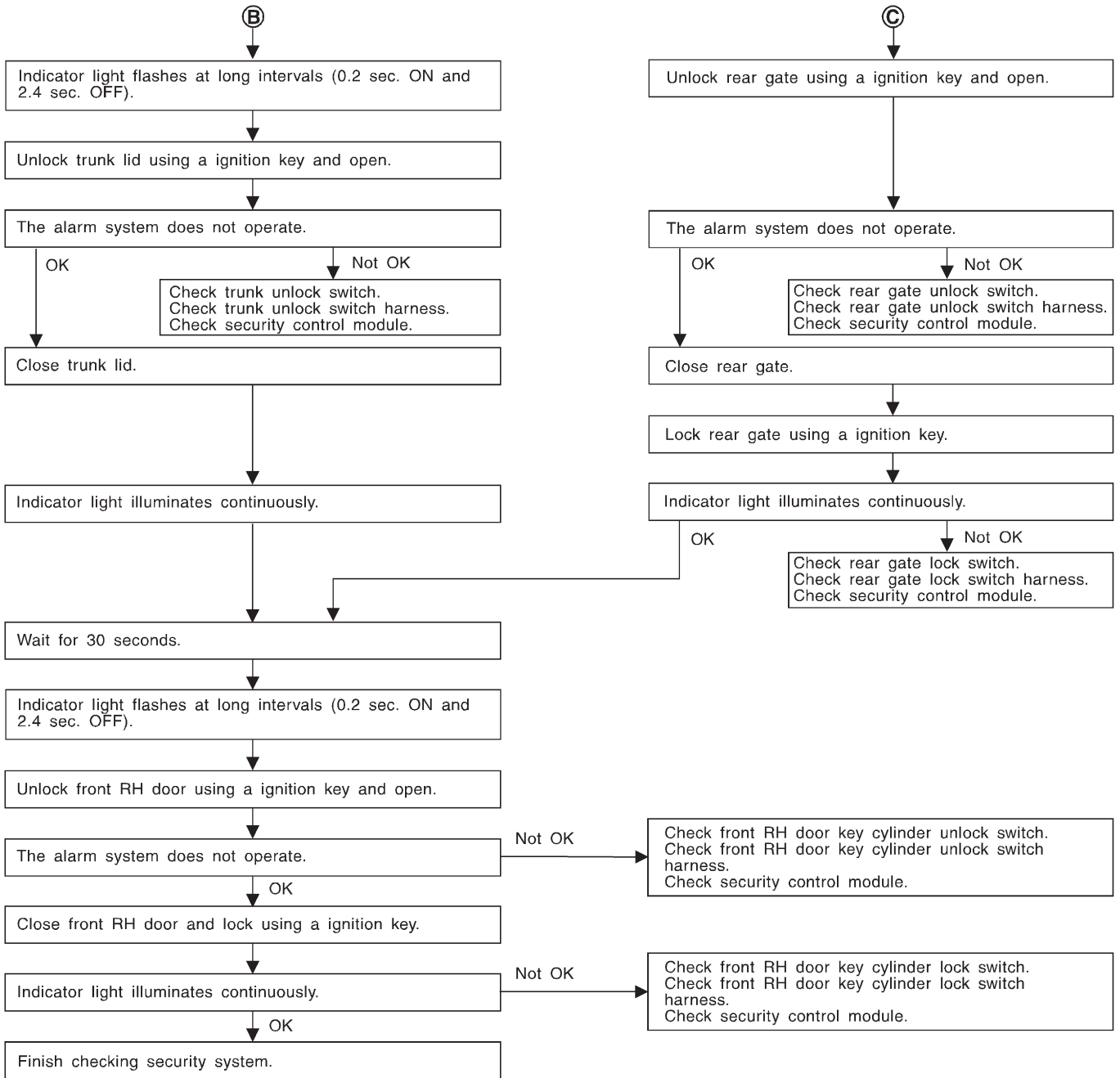

## 6-2b [T6E1] BODY ELECTRICAL SYSTEM (ELECTRICAL PARTS)

### 6. Security System

#### E: DIAGNOSTICS PROCEDURE FOR SECURITY CONTROL MODULE POWER SUPPLY/GROUND CIRCUIT

##### 6E1 : CHECK FUSE AND POWER SUPPLY CIRCUIT.

- 1) Check fuse No. 25.
- 2) Measure voltage between main fuse box connector and chassis ground.

##### Connector & terminal

(F35) No. 2 (+) — Chassis ground (-):

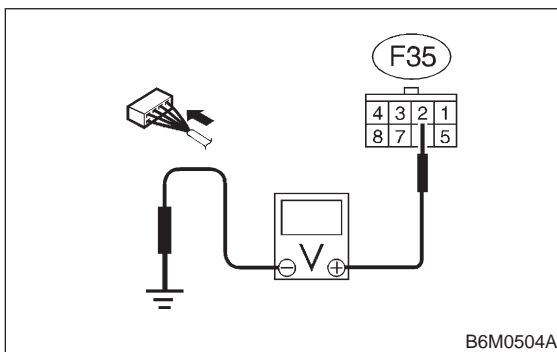

- CHECK** : Is the voltage more than 10 V?
- YES** : Go to step 6E2.
- NO** : Replace fuse or repair wiring harness. Go to step 6E2.

##### 6E2 : CHECK FUSE AND POWER SUPPLY CIRCUIT.

- 1) Disconnect connector from security control module.
- 2) Measure voltage between security control module connector and chassis ground.

##### Connector & terminal

(B93) No. 8 (+) — Chassis ground (-):

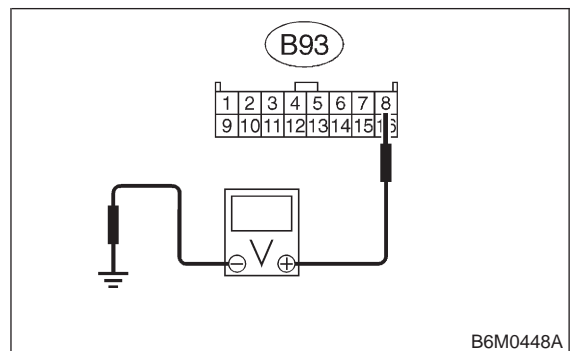

- CHECK** : Is the voltage more than 10 V?
- YES** : Go to step 6E3.
- NO** : Replace fuse or repair wiring harness. Go to step 6E3.

##### 6E3 : CHECK FUSE AND POWER SUPPLY CIRCUIT.

- 1) Check fuse No. 3.
- 2) Turn ignition switch to ACC.
- 3) Measure voltage between fuse and relay box connector and chassis ground.

##### Connector & terminal

(i5) No. 13 (+) — Chassis ground (-):

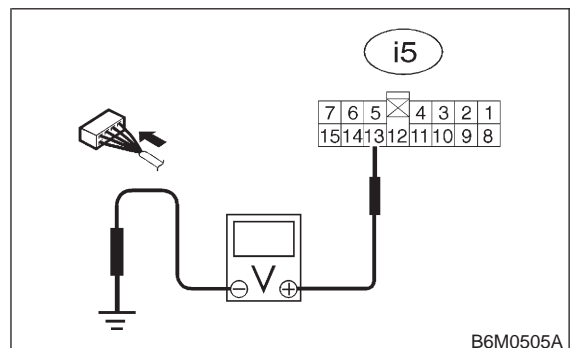

- CHECK** : Is the voltage more than 10 V?
- YES** : Go to step 6E4.
- NO** : Replace fuse or repair wiring harness. Go to step 6E4.

**6E4 : CHECK FUSE AND POWER SUPPLY CIRCUIT.**

- 1) Disconnect connector from security control module.
- 2) Measure voltage between security control module connector and chassis ground.

**Connector & terminal**

**(B93) No. 6 (+) — Chassis ground (-):**

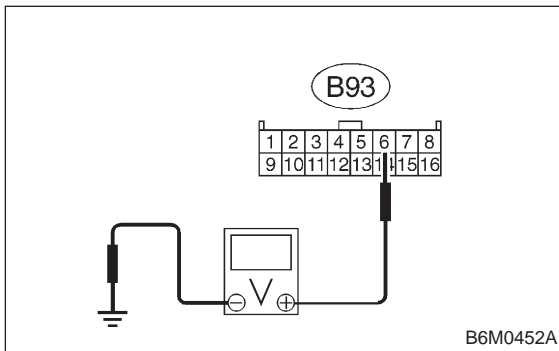

- CHECK** : *Is the voltage more than 10 V?*  
**YES** : Go to step 6E5.  
**NO** : Replace fuse or repair wiring harness.

**6E5 : CHECK GROUND CIRCUIT BETWEEN SECURITY CONTROL MODULE AND BODY.**

- 1) Turn ignition switch to OFF.
- 2) Disconnect connector of security control module.
- 3) Measure resistance of harness connector between security control module and chassis ground.

**Connector & terminal**

**(B93) No. 9 (+) — Chassis ground (-):**

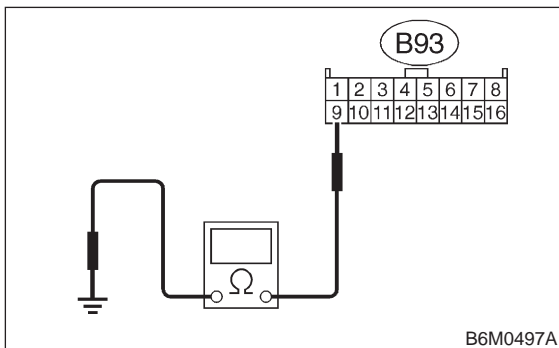

- CHECK** : *Is the resistance less than 10 Ω?*  
**YES** : Go to "BASIC DIAGNOSTICS PROCEDURE". <Ref. to 6-2b [T6D0]>.  
**NO** : Repair wiring harness.

**F: DIAGNOSTICS PROCEDURE FOR SECURITY INDICATOR LIGHT AND INDICATOR LIGHT CIRCUIT**

**6F1 : CHECK SECURITY INDICATOR LIGHT.**

- 1) Remove security indicator light.
- 2) Measure resistance between security indicator light connector terminals.

**Terminals**

**No. 2 — No. 4:**

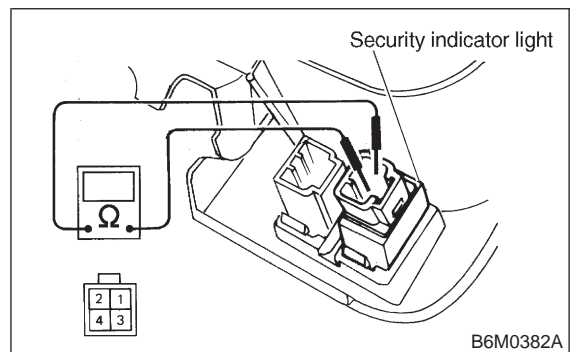

- CHECK** : *Is the resistance approx. 120 Ω?*  
**YES** : Go to step 6F2.  
**NO** : Replace indicator light.

**6F2 : CHECK POWER SUPPLY FOR INDICATOR LIGHT.**

- 1) Disconnect connector of security indicator light.
- 2) Measure voltage between security indicator light connector and chassis ground.

**Connector & terminal**

**(i8) No. 2 (+) — Chassis ground (-):**

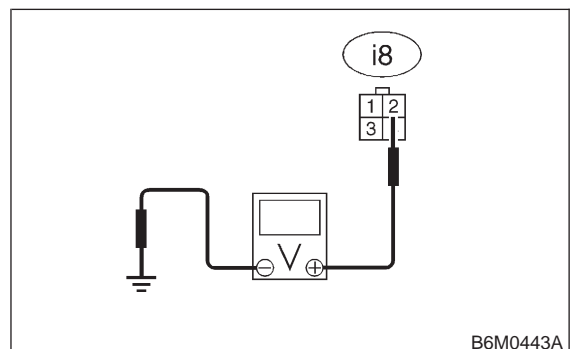

- CHECK** : *Is the voltage more than 10 V?*  
**YES** : Go to step 6F3.  
**NO** : Repair wiring harness.



## 6-2b [T6F3] BODY ELECTRICAL SYSTEM (ELECTRICAL PARTS)

### 6. Security System

#### 6F3 : CHECK HARNESS CONNECTOR BETWEEN SECURITY INDICATOR LIGHT AND SECURITY CONTROL MODULE.

- 1) Disconnect connectors of security indicator light and security control module.
- 2) Measure resistance of harness connector between security indicator light and security control module.

#### Connector & terminal

(i8) No. 4 — (B93) No. 7:

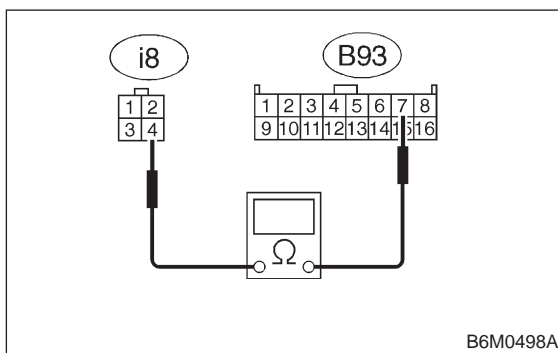

- CHECK** : Is the resistance less than 10 Ω?
- YES** : Go to "BASIC DIAGNOSTICS PROCEDURE". <Ref. to 6-2b [T6D0].>
- NO** : Repair wiring harness.

#### G: DIAGNOSTICS PROCEDURE FOR DOOR SWITCH SIGNAL

#### 6G1 : CHECK DOOR SWITCH INPUT SIGNAL FOR SECURITY CONTROL MODULE.

- 1) Remove security control module without disconnecting connector.
- 2) Turn door switch ON/OFF and measure voltage between security control module connector and chassis ground.

#### Connector & terminal

(B93) No. 4 (+) — Chassis ground (-):

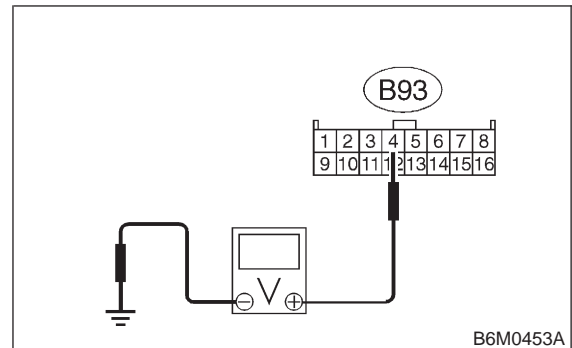

- CHECK** : Is the voltage more than 10 V? (Door closed)
- YES** : Go to "BASIC DIAGNOSTICS PROCEDURE". <Ref. to 6-2b [T6D0].> Go to step 6G2.
- NO** : Go to step 6G2.

**6G2 : CHECK DOOR SWITCH INPUT SIGNAL FOR SECURITY CONTROL MODULE.**

Turn door switch ON/OFF and measure voltage between security control module connector and chassis ground.

**Connector & terminal**

**(B93) No. 4 (+) — Chassis ground (-):**

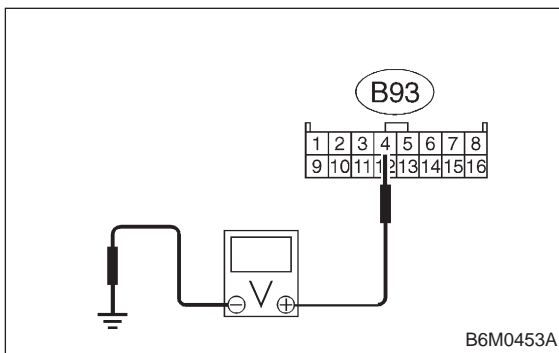

**CHECK** : **Is the voltage less than 1 V? (Door opened)**

**YES** : Go to "BASIC DIAGNOSTICS PROCEDURE". <Ref. to 6-2b [T6D0].>

**NO** : Go to step **6G3**.

**NOTE:**

When one of the doors is open, the voltage may be 1 V, max.

**6G3 : CHECK DOOR SWITCH.**

Perform inspection of door switch. <Ref. to 6-2 [W9B1].>

**NOTE:**

The door switch is used for interior light also.

**CHECK** : **Is door switch normal?**

**YES** : Repair wiring harness between door switch and security control module.

**NO** : Replace door switch.

**H: DIAGNOSTICS PROCEDURE FOR ENGINE HOOD SWITCH SIGNAL**

**6H1 : CHECK ENGINE HOOD SWITCH INPUT SIGNAL FOR SECURITY CONTROL MODULE.**

- 1) Remove security control module without disconnecting connector.
- 2) Turn engine hood switch ON/OFF and measure voltage between security control module connector and chassis ground.

**Connector & terminal**

**(B93) No. 10 (+) — Chassis ground (-):**

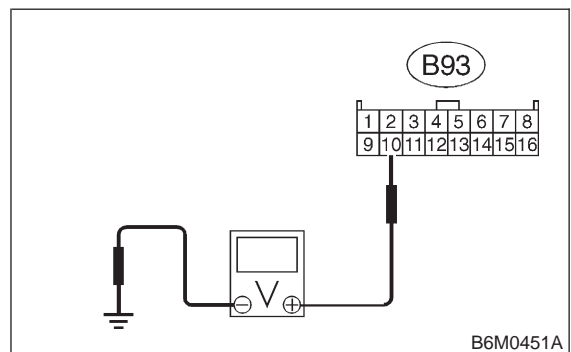

**CHECK** : **Is the voltage more than 10 V? (Hood closed)**

**YES** : Go to "BASIC DIAGNOSTICS PROCEDURE". <Ref. to 6-2b [T6D0].> Go to step **6H2**.

**NO** : Go to step **6H2**.

## 6-2b [T6H2] BODY ELECTRICAL SYSTEM (ELECTRICAL PARTS)

### 6. Security System

**6H2 : CHECK ENGINE HOOD SWITCH INPUT SIGNAL FOR SECURITY CONTROL MODULE.**

Turn engine hood switch ON/OFF and measure voltage between security control module connector and chassis ground.

**Connector & terminal**

**(B93) No. 10 (+) — Chassis ground (-):**

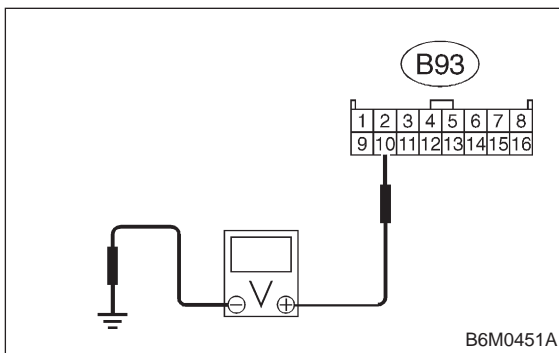

**CHECK** : **Is the voltage less than 1 V? (Hood opened)**

**YES** : Go to "BASIC DIAGNOSTICS PROCEDURE". <Ref. to 6-2b [T6D0].>

**NO** : Go to step **6H3**.

**6H3 : CHECK ENGINE HOOD SWITCH.**

Perform inspection of engine hood switch. <Ref. to 6-2 [W2300].>

**CHECK** : **Is engine hood switch normal?**

**YES** : Repair wiring harness between engine hood switch and security control module.

**NO** : Replace engine hood switch.

**I: DIAGNOSTICS PROCEDURE FOR TRUNK LID SWITCH (SEDAN) OR REAR GATE SWITCH (WAGON) SIGNAL**

**6I1 : CHECK TRUNK LID SWITCH (SEDAN) OR REAR GATE SWITCH (WAGON) INPUT SIGNAL FOR SECURITY CONTROL MODULE.**

1) Remove security control module without disconnecting connector.

2) Turn trunk lid switch (or rear gate switch) ON/OFF and measure voltage between security control module connector and chassis ground.

**Connector & terminal**

**(B93) No. 11 (+) — Chassis ground (-):**

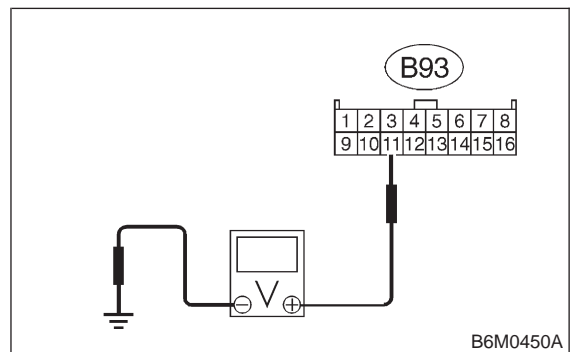

**CHECK** : **Is the voltage more than 10 V? (Lid or gate closed)**

**YES** : Go to "BASIC DIAGNOSTICS PROCEDURE". <Ref. to 6-2b [T6D0].> Go to step **6I2**.

**NO** : Go to step **6I2**.

**6I2 : CHECK TRUNK LID SWITCH (SEDAN) OR REAR GATE SWITCH (WAGON) INPUT SIGNAL FOR SECURITY CONTROL MODULE.**

Turn trunk lid switch (or rear gate switch) ON/OFF and measure voltage between security control module connector and chassis ground.

**Connector & terminal**  
**(B93) No. 11 (+) — Chassis ground (-):**

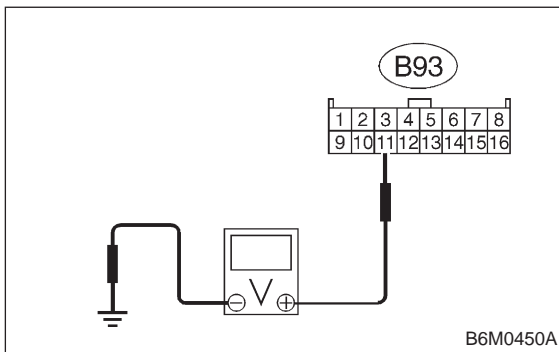

- CHECK** : **Is the voltage less than 1 V? (Lid or gate opened)**
- YES** : Go to "BASIC DIAGNOSTICS PROCEDURE". <Ref. to 6-2b [T6D0].>
- NO** : Go to step **6I3**.

**6I3 : CHECK TRUNK LID SWITCH (SEDAN) OR REAR GATE SWITCH (WAGON).**

Perform inspection of trunk lid switch/rear gate switch. <Ref. to 6-2 [W9B2].> — <Ref. to 6-2 [W9B3].>

**NOTE:**

The trunk lid switch/rear gate switch is used for both trunk room light/luggage room light.

- CHECK** : **Is trunk lid or rear gate switch normal?**
- YES** : Repair wiring harness between trunk lid or rear gate switch and security control module.
- NO** : Replace trunk lid or rear gate switch.

**J: DIAGNOSTICS PROCEDURE FOR DOOR LOCK/UNLOCK SWITCH SIGNAL**

**6J1 : CHECK DOOR LOCK/UNLOCK SWITCH INPUT SIGNAL FOR SECURITY CONTROL MODULE.**

- 1) Remove security control module without disconnecting connector.
- 2) Close all the doors and rear gate (WAGON), and lock with ignition key.
- 3) Measure voltage between security control module connector and chassis ground.

**Connector & terminal**  
**(B93) No. 1 (+) — Chassis ground (-):**

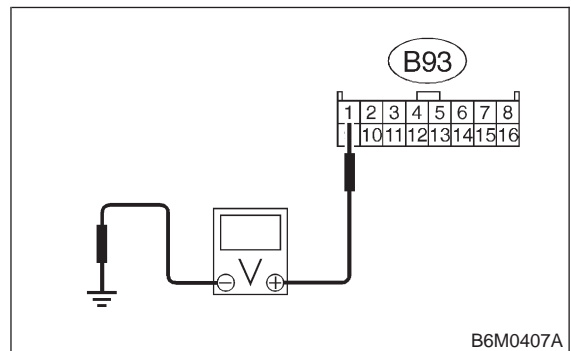

- CHECK** : **Is the voltage more than 10 V?**
- YES** : Go to "BASIC DIAGNOSTICS PROCEDURE". <Ref. to 6-2b [T6D0].> Go to step **6J2**.
- NO** : Go to step **6J2**.

**NOTE:**

When one of the door (driver, passenger or rear gate) lock knobs is in unlocked position, the voltage may be 1 V, max.

## 6-2b [T6J2] BODY ELECTRICAL SYSTEM (ELECTRICAL PARTS)

### 6. Security System

#### 6J2 : CHECK DOOR LOCK/UNLOCK SWITCH INPUT SIGNAL FOR SECURITY CONTROL MODULE.

- 1) Unlock the door with ignition key.
- 2) Measure voltage between security control module connector and chassis ground.

##### Connector & terminal

(B93) No. 1 (+) — Chassis ground (-):

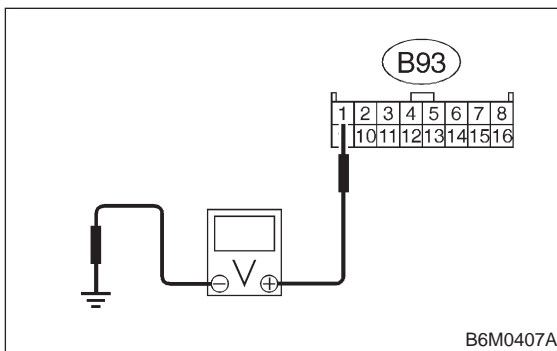

- CHECK** : Is the voltage less than 1 V?
- YES** : Go to "BASIC DIAGNOSTICS PROCEDURE". <Ref. to 6-2b [T6D0].>
- NO** : Go to step 6J3.

#### 6J3 : CHECK DOOR LOCK/UNLOCK SWITCH.

Perform inspection of door lock/unlock switch. <Ref. to 6-2 [W2300].>

- CHECK** : Is door lock/unlock switch normal?
- YES** : Repair wiring harness between door lock/unlock switch and security control module.
- NO** : Replace door lock/unlock switch.

#### K: DIAGNOSTICS PROCEDURE FOR KEY CYLINDER LOCK/UNLOCK SWITCH AND TAMPER SWITCH SIGNAL

##### NOTE:

Key cylinder lock switch, key cylinder unlock switch and tamper switch are combined as a control module.

#### 6K1 : CHECK KEY CYLINDER SWITCH INPUT SIGNAL FOR SECURITY CONTROL MODULE (ALL DOORS AND REAR GATE).

- 1) Remove security control module without disconnecting connector.
- 2) Measure voltage between security control module connector and chassis ground while turning key cylinder with ignition key.

##### Connector & terminal

(B93) No. 2 (+) — Chassis ground (-):

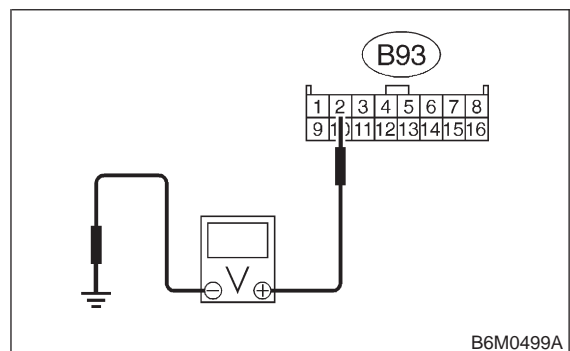

- CHECK** : Is the voltage less than 1 V? (LOCK position)
- YES** : Go to "BASIC DIAGNOSTICS PROCEDURE". <Ref. to 6-2b [T6D0].> Go to step 6K2.
- NO** : Go to step 6K2.

**6K2 : CHECK KEY CYLINDER SWITCH INPUT SIGNAL FOR SECURITY CONTROL MODULE (ALL DOORS AND REAR GATE).**

Measure voltage between security control module connector and chassis ground while turning key cylinder with ignition key.

**Connector & terminal**  
**(B93) No. 2 (+) — Chassis ground (-):**

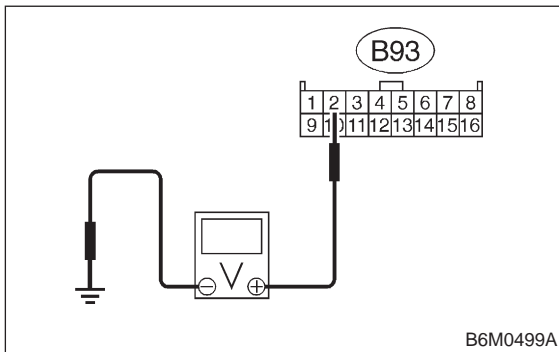

- CHECK** : **Is the voltage more than 10 V? (Other than LOCK position)**
- YES** : Go to "BASIC DIAGNOSTICS PROCEDURE". <Ref. to 6-2b [T6D0].> Go to step **6K3**.
- NO** : Go to step **6K3**.

**6K3 : CHECK KEY CYLINDER SWITCH INPUT SIGNAL FOR SECURITY CONTROL MODULE (ALL DOORS AND REAR GATE).**

Measure voltage between security control module connector and chassis ground while turning key cylinder with ignition key.

**Connector & terminal**  
**(B93) No. 14 (+) — Chassis ground (-):**

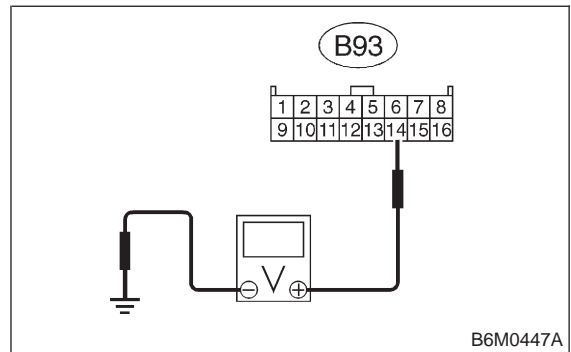

- CHECK** : **Is the voltage less than 1 V? (UNLOCK position)**
- YES** : Go to "BASIC DIAGNOSTICS PROCEDURE". <Ref. to 6-2b [T6D0].> Go to step **6K4**.
- NO** : Go to step **6K4**.

## 6-2b [T6K4] BODY ELECTRICAL SYSTEM (ELECTRICAL PARTS)

### 6. Security System

**6K4 : CHECK KEY CYLINDER SWITCH INPUT SIGNAL FOR SECURITY CONTROL MODULE (ALL DOORS AND REAR GATE).**

Measure voltage between security control module connector and chassis ground while turning key cylinder with ignition key.

#### Connector & terminal

**(B93) No. 14 (+) — Chassis ground (-):**

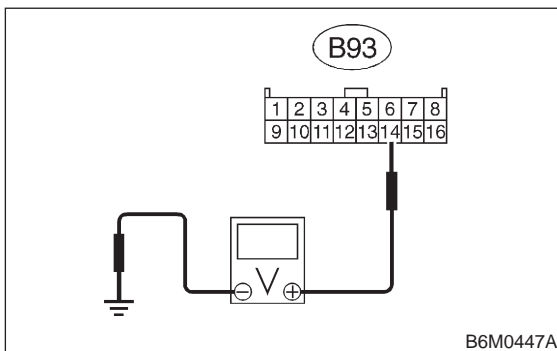

- CHECK** : Is the voltage more than 10 V? (Other than UNLOCK position)
- YES** : Go to "BASIC DIAGNOSTICS PROCEDURE". <Ref. to 6-2b [T6D0].> Go to step **6K5**.
- NO** : Go to step **6K5**.

**6K5 : CHECK KEY CYLINDER SWITCH INPUT SIGNAL FOR SECURITY CONTROL MODULE (TRUNK LID).**

Measure voltage between security control module connector and chassis ground while turning key cylinder with ignition key.

#### Connector & terminal

**(B93) No. 15 (+) — Chassis ground (-):**

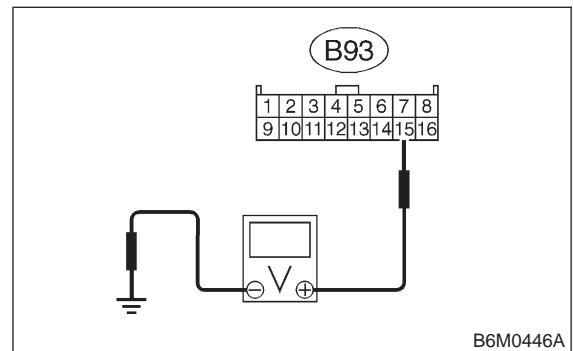

- CHECK** : Is the voltage less than 1 V? (UNLOCK position)
- YES** : Go to "BASIC DIAGNOSTICS PROCEDURE". <Ref. to 6-2b [T6D0].> Go to step **6K6**.
- NO** : Go to step **6K6**.

**6K6 : CHECK KEY CYLINDER SWITCH INPUT SIGNAL FOR SECURITY CONTROL MODULE (TRUNK LID).**

Measure voltage between security control module connector and chassis ground while turning key cylinder with ignition key.

**Connector & terminal**  
**(B93) No. 15 (+) — Chassis ground (-):**

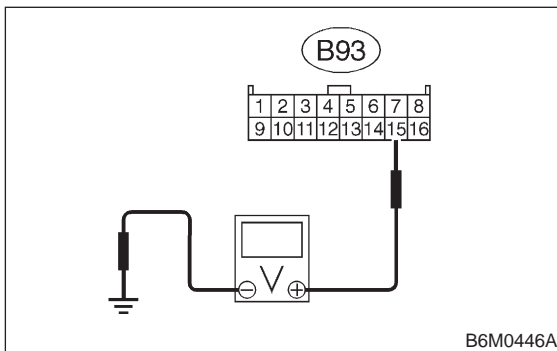

- CHECK** : *Is the voltage more than 10 V? (Other than UNLOCK position)*
- YES** : Go to "BASIC DIAGNOSTICS PROCEDURE". <Ref. to 6-2b [T6D0].> Go to step **6K7**.
- NO** : Go to step **6K7**.

**6K7 : CHECK KEY CYLINDER SWITCH INPUT SIGNAL FOR SECURITY CONTROL MODULE.**

Measure voltage between security control module connector and chassis ground while installing key cylinder switch to door outer handle.

**Connector & terminal**  
**(B93) No. 3 (+) — Chassis ground (-):**

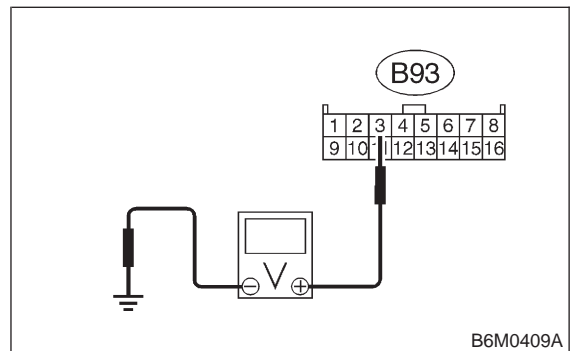

- CHECK** : *Is the voltage more than 10 V? (Switch is installed.)*
- YES** : Go to "BASIC DIAGNOSTICS PROCEDURE". <Ref. to 6-2b [T6D0].> Go to step **6K8**.
- NO** : Go to step **6K8**.



## 6-2b [T6K8] BODY ELECTRICAL SYSTEM (ELECTRICAL PARTS)

### 6. Security System

#### 6K8 : CHECK KEY CYLINDER SWITCH INPUT SIGNAL FOR SECURITY CONTROL MODULE.

Measure voltage between security control module connector and chassis ground while removing key cylinder switch from door outer handle.

##### Connector & terminal

(B93) No. 3 (+) — Chassis ground (-):

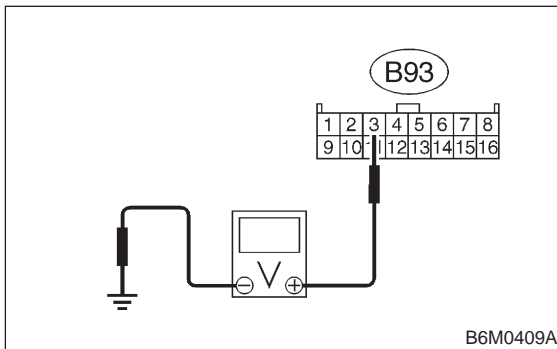

**CHECK** : Is the voltage less than 1 V? (Switch is removed.)

**YES** : Go to "BASIC DIAGNOSTICS PROCEDURE". <Ref. to 6-2b [T6D0].>

**NO** : Go to step 6K9.

##### NOTE:

For SEDAN vehicles, remove key cylinder switch from trunk lid key cylinder to perform the above inspection.

#### 6K9 : CHECK KEY CYLINDER SWITCH.

Perform inspection of key cylinder lock/unlock switch and tamper switch. <Ref. to 6-2 [W2300].>

**CHECK** : Is key cylinder switch normal?

**YES** : Repair wiring harness between key cylinder switch and security control module.

**NO** : Replace key cylinder switch.

#### L: DIAGNOSTICS PROCEDURE FOR STARTER INTERRUPT SIGNAL

#### 6L1 : CHECK STARTER INTERRUPT OUTPUT SIGNAL FOR SECURITY CONTROL MODULE.

1) Remove security control module without disconnecting connector.

2) Measure voltage between security control module connector and chassis ground.

##### Connector & terminal

(B93) No. 5 (+) — Chassis ground (-):

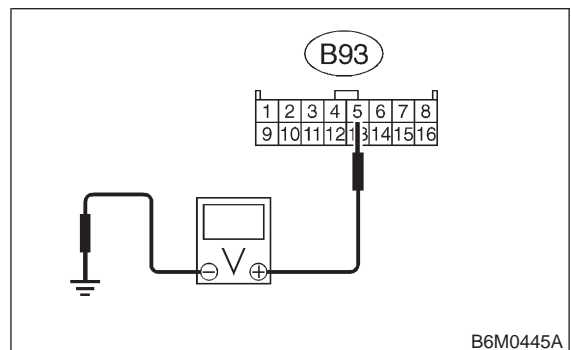

**CHECK** : Is the voltage more than 10 V?

**YES** : Go to step 6L6.

**NO** : Go to step 6L2.

**6L2 : CHECK STARTER INTERRUPT OUTPUT SIGNAL FOR SECURITY CONTROL MODULE.**

- 1) Set security system in armed state.
- 2) Open the door without ignition key to operate the security system (alarm state).
- 3) Measure voltage between security control module and chassis ground during alarm state.

**Connector & terminal**  
**(B93) No. 5 (+) — Chassis ground (-):**

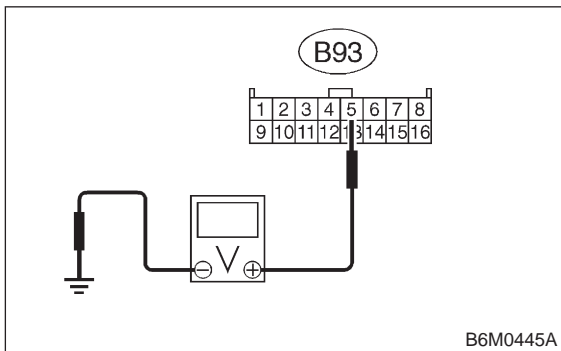

- CHECK** : *Is the voltage less than 1 V?*
- YES** : Go to step 6L6.
- NO** : Go to step 6L3.

**6L3 : CHECK POWER SUPPLY FOR STARTER INTERRUPT RELAY.**

- 1) Remove starter interrupt relay without disconnecting connector.
- 2) Measure voltage between starter interrupt relay connector and chassis ground.

**Connector & terminal**  
**(B59) No. 1 (+) — Chassis ground (-):**

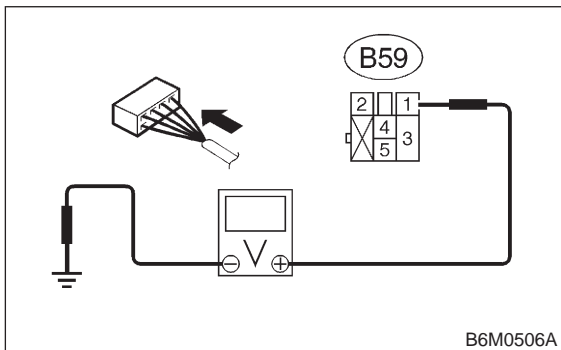

- CHECK** : *Is the voltage more than 10 V?*
- YES** : Go to step 6L4.
- NO** : Repair wiring harness between starter interrupt relay and battery.

**6L4 : CHECK CONTINUITY OF STARTER INTERRUPT RELAY.**

- 1) Remove starter interrupt relay.
- 2) Check continuity between terminals No. 1 and No. 2 of starter interrupt relay.

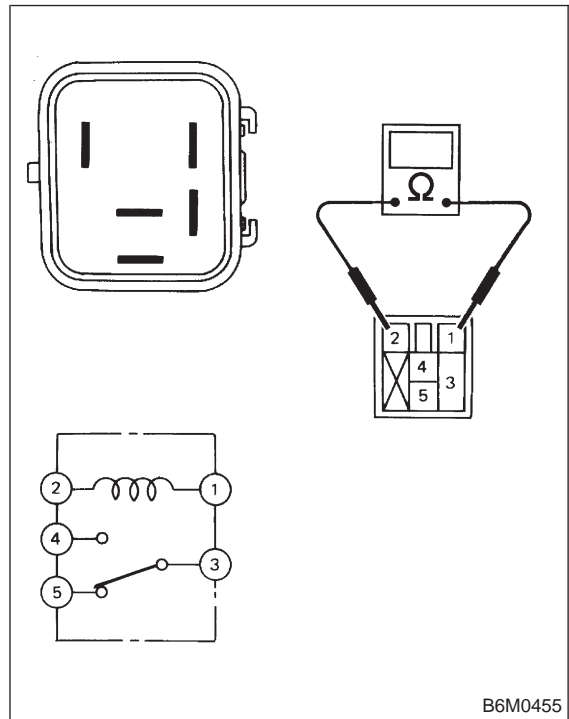

- CHECK** : *Is starter interrupt relay normal?*
- YES** : Go to step 6L5.
- NO** : Replace starter interrupt relay.

## 6-2b [T6L5] BODY ELECTRICAL SYSTEM (ELECTRICAL PARTS)

### 6. Security System

#### 6L5 : CHECK HARNESS CONNECTOR BETWEEN STARTER INTERRUPT RELAY AND SECURITY CONTROL MODULE.

- 1) Disconnect connectors of starter interrupt relay and security control module.
- 2) Measure resistance of harness connector between starter interrupt relay and security control module.

##### Connector & terminal

(B59) No. 2 — (B93) No. 5:

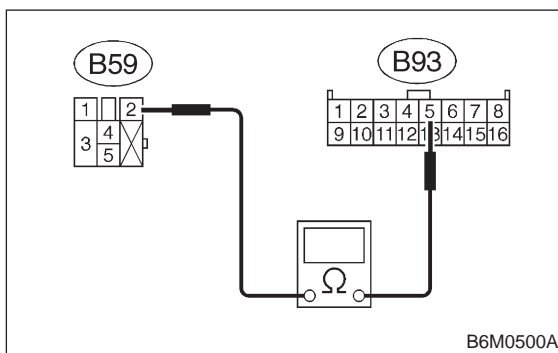

- CHECK** : *Is the resistance less than 10 Ω?*
- YES** : Replace security control module.
- NO** : Repair wiring harness between starter interrupt relay and security control module.

#### 6L6 : CHECK STARTER INTERRUPT RELAY.

Perform inspection of starter interrupt relay. <Ref. to 6-2 [W22B1].>

- CHECK** : *Is starter interrupt relay normal?*
- YES** : Repair wiring harness of starter motor circuit.
- NO** : Replace starter interrupt relay.

#### M: DIAGNOSTICS PROCEDURE FOR HORN ALARM SIGNAL

#### 6M1 : CHECK HORN ALARM OUTPUT SIGNAL FOR SECURITY CONTROL MODULE.

- 1) Remove security control module without disconnecting connector.
- 2) Measure voltage between security control module connector and chassis ground.

##### Connector & terminal

(B93) No. 13 (+) — Chassis ground (-):

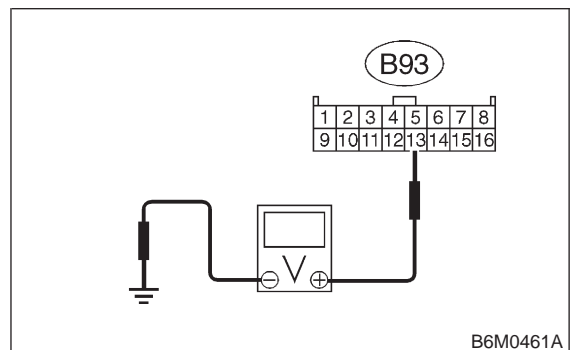

- CHECK** : *Is the voltage more than 10 V?*
- YES** : Go to step 6M6.
- NO** : Go to step 6M2.

**6M2 : CHECK HORN ALARM OUTPUT SIGNAL FOR SECURITY CONTROL MODULE.**

- 1) Set security system in armed state.
- 2) Open the door without ignition key to operate the security system (alarm state).
- 3) Measure voltage between security control module and chassis ground during alarm state.

**Connector & terminal**  
**(B93) No. 13 (+) — Chassis ground (-):**

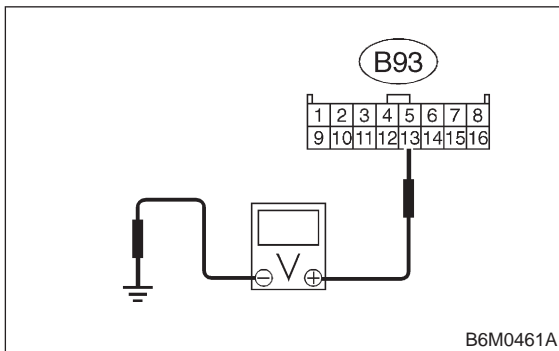

- CHECK** : Does the voltage interval repeat between less than 1 V (0.2 sec.) and more than 10 V (0.6 sec.)?
- YES** : Go to step 6M6.
- NO** : Go to step 6M3.

**6M3 : CHECK POWER SUPPLY FOR HORN RELAY.**

- 1) Check fuse No. 12.
- 2) Remove horn relay without disconnecting connector.
- 3) Measure voltage between horn relay connector and chassis ground.

**Connector & terminal**  
**(B49) No. 2 (+) — Chassis ground (-):**

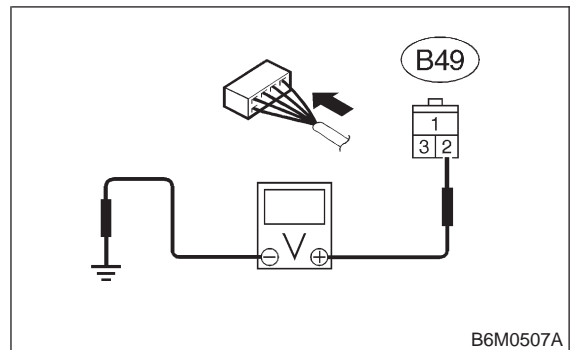

- CHECK** : Is the voltage more than 10 V?
- YES** : Go to step 6M4.
- NO** : Repair wiring harness between horn relay and battery.

**6M4 : CHECK CONTINUITY OF HORN RELAY.**

- 1) Remove horn relay.
- 2) Check continuity between terminals No. 1 and No. 2 of horn relay.

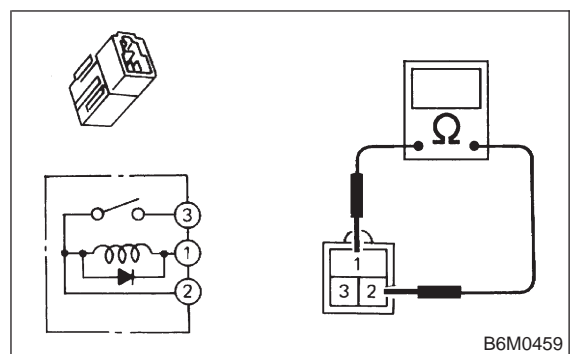

- CHECK** : Is horn relay normal?
- YES** : Go to step 6M5.
- NO** : Replace horn relay.

## 6-2b [T6M5] BODY ELECTRICAL SYSTEM (ELECTRICAL PARTS)

### 6. Security System

#### 6M5 : CHECK HARNESS CONNECTOR BETWEEN HORN RELAY AND SECURITY CONTROL MODULE.

- 1) Disconnect connectors of horn relay and security control module.
- 2) Measure resistance of harness connector between horn relay and security control module.

##### Connector & terminal

(B49) No. 1 (+) — (B93) No. 13:

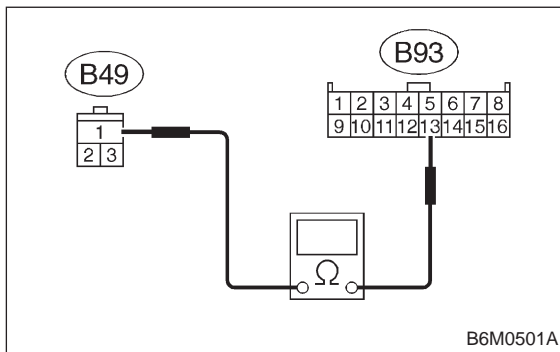

- CHECK** : Is the resistance less than 10 Ω?
- YES** : Replace security control module.
- NO** : Repair wiring harness between horn relay and security control module.

#### 6M6 : CHECK HORN RELAY.

Perform inspection of horn relay. <Ref. to 6-2 [W16B2].>

- CHECK** : Is horn relay normal?
- YES** : Repair wiring harness of horn circuit.
- NO** : Replace horn relay.

#### N: DIAGNOSTICS PROCEDURE FOR HEADLIGHT ALARM SIGNAL

#### 6N1 : CHECK HEADLIGHT ALARM OUTPUT SIGNAL FOR SECURITY CONTROL MODULE.

- 1) Remove security control module without disconnecting connector.
- 2) Measure voltage between security control module connector and chassis ground.

##### Connector & terminal

(B93) No. 12 (+) — Chassis ground (-):

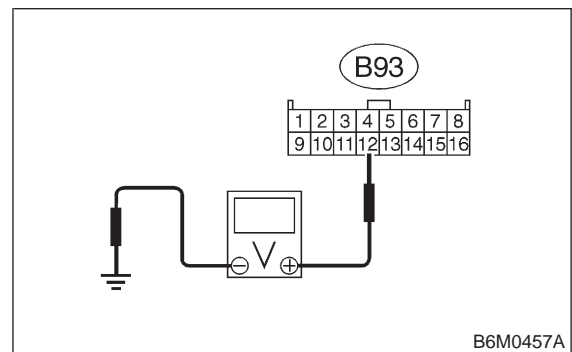

- CHECK** : Is the voltage more than 10 V?
- YES** : Go to step 6N6.
- NO** : Go to step 6N2.

**6N2 : CHECK HEADLIGHT ALARM OUTPUT SIGNAL FOR SECURITY CONTROL MODULE.**

- 1) Set security system in armed state.
- 2) Open the door without ignition key to operate the security system (alarm state).
- 3) Measure voltage between security control module and chassis ground during alarm state.

**Connector & terminal**

**(B93) No. 12 (+) — Chassis ground (-):**

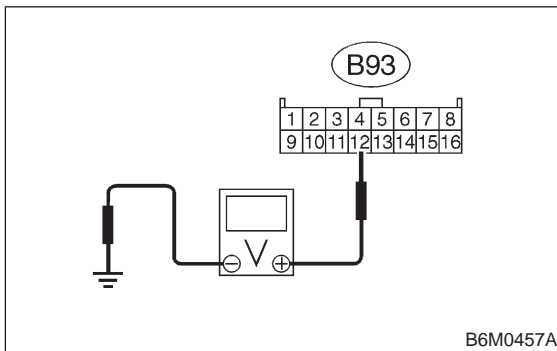

**CHECK** : Does the voltage interval repeat between less than 1 V (0.2 sec.) and more than 10 V (0.6 sec.)?

**YES** : Go to step 6N6.

**NO** : Go to step 6N3.

**6N3 : CHECK POWER SUPPLY FOR HEADLIGHT ALARM RELAY.**

- 1) Remove headlight alarm relay without disconnecting connector.
- 2) Measure voltage between headlight alarm relay connector and chassis ground.

**Connector & terminal**

**(B58) No. 1 (+) — Chassis ground (-):**

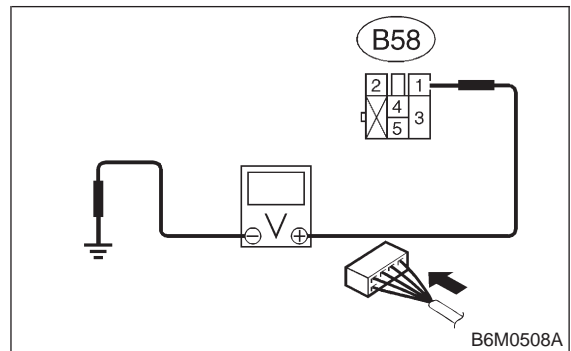

**CHECK** : Is the voltage more than 10 V?

**YES** : Go to step 6N4.

**NO** : Repair wiring harness between headlight alarm relay and battery.

## 6-2b [T6N4] BODY ELECTRICAL SYSTEM (ELECTRICAL PARTS)

### 6. Security System

#### 6N4 : CHECK CONTINUITY OF HEADLIGHT ALARM RELAY.

- 1) Remove headlight alarm relay.
- 2) Check continuity between terminals No. 1 and No. 2 of headlight alarm relay.

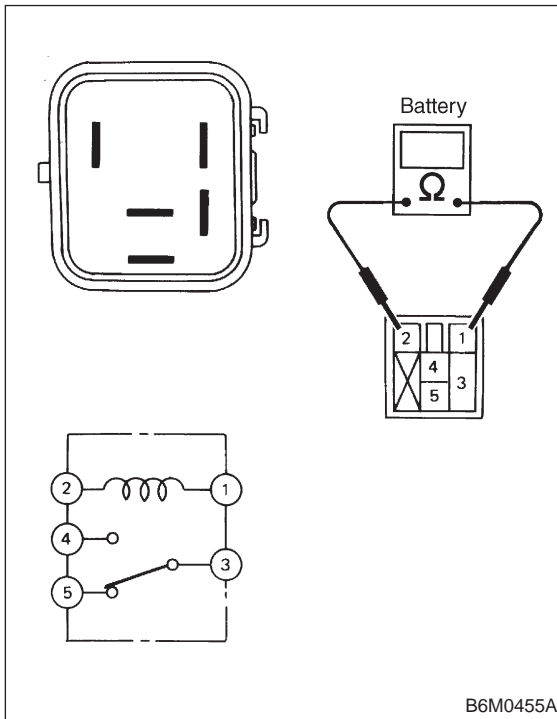

- CHECK** : Is headlight alarm relay normal?
- YES** : Go to step 6N5.
- NO** : Replace headlight alarm relay.

#### 6N5 : CHECK HARNESS CONNECTOR BETWEEN HEADLIGHT ALARM RELAY AND SECURITY CONTROL MODULE.

- 1) Disconnect connectors of headlight alarm relay and security control module.
- 2) Measure resistance of harness connector between headlight alarm relay and security control module.

##### Connector & terminal

(B58) No. 2 — (B93) No. 12:

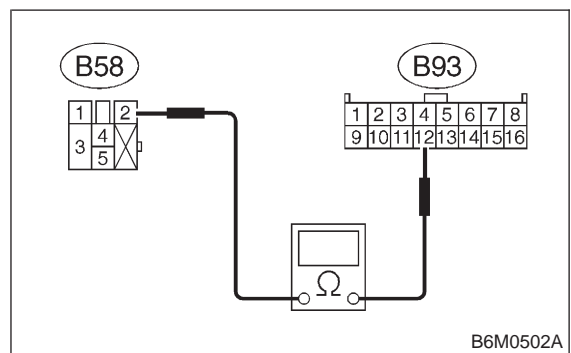

- CHECK** : Is the resistance less than 10 Ω?
- YES** : Replace security control module.
- NO** : Repair wiring harness between headlight alarm relay and security control module.

#### 6N6 : CHECK HEADLIGHT ALARM RELAY.

Perform inspection of headlight alarm relay. <Ref. to 6-2 [W2300].>

- CHECK** : Is headlight alarm relay normal?
- YES** : Repair wiring harness of headlight circuit.
- NO** : Replace headlight alarm relay.