

## 5. Diagnostics Chart with Trouble Code

### A: TROUBLE CODES

#### 1. LIST OF TROUBLE CODES

Trouble code/ Contents of troubles	Memory function	Contents of diagnosis	Index No.
03	Provided.	<ul style="list-style-type: none"> <li>● Front sub sensor harness is faulty.</li> <li>● Front sub sensor is faulty.</li> </ul>	<Ref. to 5-5 [T5B0].>
04	Provided.	<ul style="list-style-type: none"> <li>● Airbag main harness circuit is shorted.</li> <li>● Passenger's airbag module harness circuit is shorted.</li> <li>● Airbag control module is faulty.</li> </ul>	<Ref. to 5-5 [T5C0].>
08	Provided.	<ul style="list-style-type: none"> <li>● Airbag control module is faulty.</li> <li>● Airbag main harness is faulty.</li> </ul>	<Ref. to 5-5 [T5D0].>
09	Provided.	<ul style="list-style-type: none"> <li>● Airbag control module is faulty.</li> <li>● Airbag main harness is faulty.</li> </ul>	<Ref. to 5-5 [T5E0].>
11	Provided.	<ul style="list-style-type: none"> <li>● Airbag control module is faulty.</li> <li>● Airbag main harness circuit is open.</li> <li>● Fuse No. 8 is blown.</li> <li>● Body harness circuit is open.</li> </ul>	<Ref. to 5-5 [T5F0].>
12	Provided.	<ul style="list-style-type: none"> <li>● Airbag main harness circuit is open.</li> <li>● Driver's airbag module harness circuit is open.</li> <li>● Roll connector circuit is open.</li> <li>● Airbag control module is faulty.</li> </ul>	<Ref. to 5-5 [T5G0].>
13	Provided.	<ul style="list-style-type: none"> <li>● Airbag main harness circuit is shorted.</li> <li>● Driver's airbag module harness is shorted.</li> <li>● Roll connector circuit is shorted.</li> <li>● Airbag control module is faulty.</li> </ul>	<Ref. to 5-5 [T5H0].>
14	Not provided.	(AB6), (AB17) and (AB18) are not connected properly to airbag control module.	<Ref. to 5-5 [T5I0].>
15	Provided.	<ul style="list-style-type: none"> <li>● Side airbag sensor (RH) is faulty.</li> <li>● Airbag main harness is faulty.</li> </ul>	<Ref. to 5-5 [T5J0].>
16	Provided.	<ul style="list-style-type: none"> <li>● Side airbag sensor (RH) is faulty.</li> <li>● Side airbag sensor is different.</li> </ul>	<Ref. to 5-5 [T5K0].>
21	Provided.	Airbag control module is faulty.	<Ref. to 5-5 [T5L0].>
22	Provided.	<ul style="list-style-type: none"> <li>● Airbag main harness circuit is open.</li> <li>● Passenger's airbag module harness circuit is open.</li> <li>● Airbag control module is faulty.</li> </ul>	<Ref. to 5-5 [T5M0].>
25	Provided.	<ul style="list-style-type: none"> <li>● Side airbag sensor (LH) is faulty.</li> <li>● Airbag main harness is faulty.</li> </ul>	<Ref. to 5-5 [T5N0].>
26	Provided.	<ul style="list-style-type: none"> <li>● Side airbag sensor (LH) is faulty.</li> <li>● Side airbag sensor is different.</li> </ul>	<Ref. to 5-5 [T5O0].>
31	Not provided.	<ul style="list-style-type: none"> <li>● Airbag control module is faulty.</li> <li>● Airbag main harness circuit is open.</li> <li>● Fuse No. 16 is blown.</li> <li>● Body harness circuit is open.</li> </ul>	<Ref. to 5-5 [T5P0].>
33	Provided.	Front airbag module is inflated.	<Ref. to 5-5 [T5Q0].>
34	Provided.	<ul style="list-style-type: none"> <li>● Passenger's airbag main harness circuit is shorted to power supply.</li> <li>● Passenger's airbag module harness is shorted to power supply.</li> <li>● Airbag control module is faulty.</li> </ul>	<Ref. to 5-5 [T5R0].>

## 5-5 [T5A1]

## SUPPLEMENTAL RESTRAINT SYSTEM

### 5. Diagnostics Chart with Trouble Code

Trouble code/ Contents of troubles	Memory function	Contents of diagnosis	Index No.
41	Provided.	<ul style="list-style-type: none"> <li>● Driver's airbag main harness circuit is shorted to ground.</li> <li>● Driver's airbag module harness circuit is shorted to ground.</li> <li>● Roll connector circuit is shorted to ground.</li> <li>● Airbag control module is faulty.</li> </ul>	<Ref. to 5-5 [T5S0].>
42	Provided.	<ul style="list-style-type: none"> <li>● Passenger's airbag main harness circuit is shorted to ground.</li> <li>● Passenger's airbag module harness circuit is shorted to ground.</li> <li>● Airbag control module is faulty.</li> </ul>	<Ref. to 5-5 [T5T0].>
43	Provided.	<ul style="list-style-type: none"> <li>● Driver's airbag main harness circuit is shorted to power supply.</li> <li>● Driver's airbag module harness is shorted to power supply.</li> <li>● Roll connector is shorted to power supply.</li> <li>● Airbag control module is faulty.</li> </ul>	<Ref. to 5-5 [T5U0].>
44	Provided.	Side airbag module is inflated.	<Ref. to 5-5 [T5V0].>
51	Provided.	<ul style="list-style-type: none"> <li>● Airbag main harness is faulty.</li> <li>● Side airbag module (RH) is faulty.</li> <li>● Airbag control module is faulty.</li> </ul>	<Ref. to 5-5 [T5W0].>
52	Provided.	<ul style="list-style-type: none"> <li>● Airbag main harness is faulty.</li> <li>● Side airbag module (LH) is faulty.</li> <li>● Airbag control module is faulty.</li> </ul>	<Ref. to 5-5 [T5X0].>
Airbag warning light remains on.	Not provided.	<ul style="list-style-type: none"> <li>● Airbag warning light is faulty.</li> <li>● Airbag control module to airbag warning light harness circuit is shorted or open.</li> <li>● Grounding circuit is faulty.</li> <li>● Airbag control module is faulty.</li> <li>● (AB1) and (B31) are not connected properly.</li> <li>● (AB6) is not connected properly to airbag control module.</li> </ul>	<Ref. to 5-5 [T5Y0].>
Airbag warning light remains off.	Not provided.	<ul style="list-style-type: none"> <li>● Fuse No. 15 is blown.</li> <li>● Body harness circuit is open.</li> <li>● Airbag warning light is faulty.</li> <li>● Airbag main harness is faulty.</li> <li>● Airbag control module is faulty.</li> </ul>	<Ref. to 5-5 [T5Z0].>
Warning light indicates trouble code, then normal code. (Flashing trouble code.)	Provided.	Airbag system component parts are faulty.	<Ref. to 5-5 [T5AA0].>
Warning light indicates trouble code, then normal code. (Flashing normal code.)	Not provided.	<ul style="list-style-type: none"> <li>● Airbag connector is faulty.</li> <li>● Fuse No. 16 is blown.</li> <li>● Airbag main harness is faulty.</li> <li>● Airbag control module is faulty.</li> <li>● Body harness is faulty.</li> </ul>	<Ref. to 5-5 [T5AB0].>

2. HOW TO READ TROUBLE CODES

The AIRBAG warning light flashes a code corresponding to the faulty parts.  
The long segment (1.2 sec on) indicates a “ten”, and the short segment (0.3 sec on) indicates a “one”.

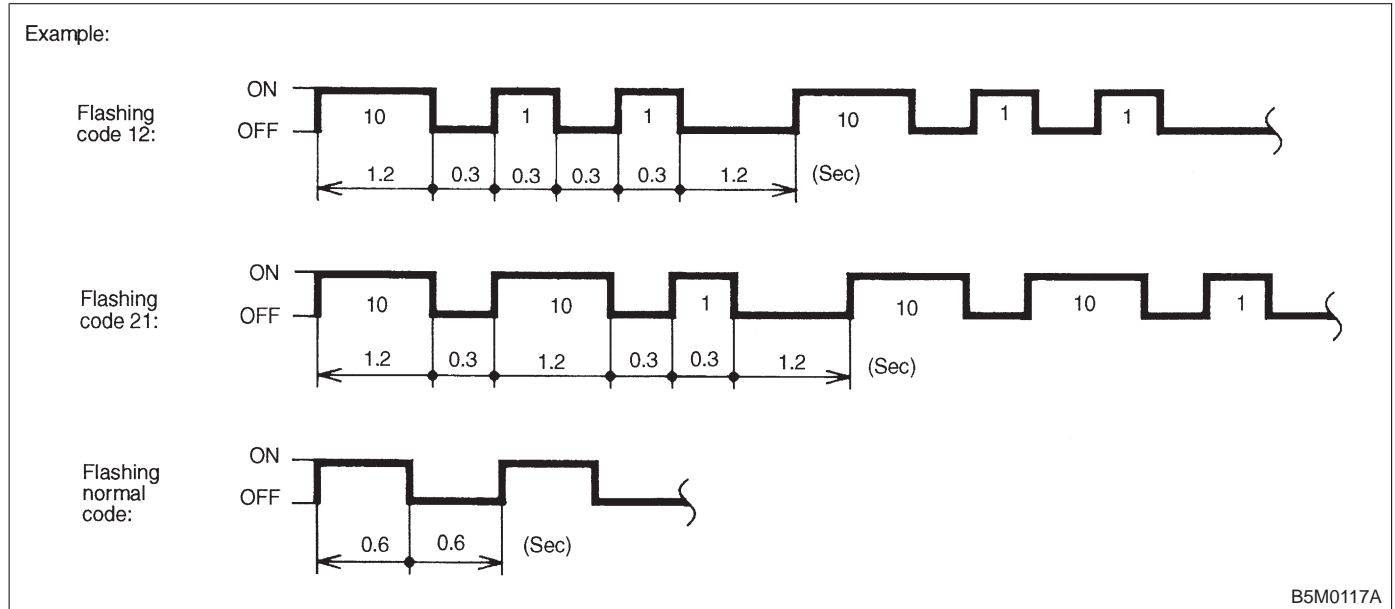

B: TROUBLE CODE 03

DIAGNOSIS:

- Front sub sensor harness is faulty.
- Front sub sensor is faulty.

CAUTION:

Before performing diagnostics on airbag system, turn ignition switch “OFF”, disconnect battery ground terminal, and then wait at least 20 seconds. <Ref. to 5-5 [W7A0].>

5B1 : FRONT SUB SENSOR (RH) AND FRONT SUB SENSOR HARNESS (RH) INSPECTION

- 1) Disconnect connector (AB6) from airbag control module <Ref. to 5-5 [W5A0].>, and connect it to test harness E connector (1E).
- 2) Measure resistance between test harness E connector (3E) terminal.

Connector & terminal  
(3E) No. 2 — (3E) No. 4:

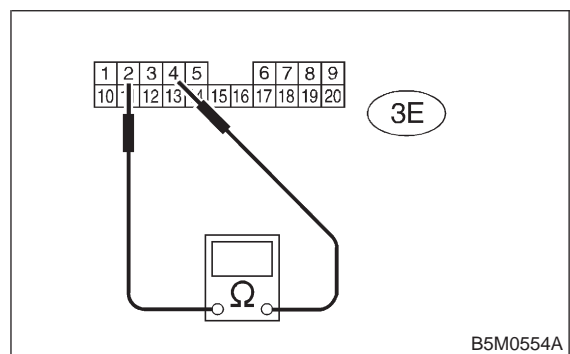

**CHECK** : Is the resistance between 750 Ω and 1 kΩ?

**YES** : Go to step 5B2.

**NO** : Go to step 5B2.

## 5-5 [T5B2]

# SUPPLEMENTAL RESTRAINT SYSTEM

### 5. Diagnostics Chart with Trouble Code

#### 5B2 : FRONT SUB SENSOR (RH) AND FRONT SUB SENSOR HARNESS (RH) INSPECTION

Measure resistance across test harness E connector (3E) terminal and chassis ground.

##### Connector & terminal

(3E) No. 2 (+) — Chassis ground (-):

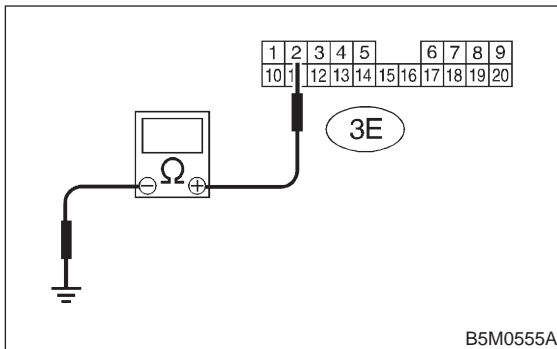

- CHECK** : Is the resistance more than 10 kΩ?  
**YES** : Go to step 5B3.  
**NO** : Go to step 5B3.

#### 5B3 : FRONT SUB SENSOR (RH) AND FRONT SUB SENSOR HARNESS (RH) INSPECTION

Measure resistance across test harness E connector (3E) terminal and chassis ground.

##### Connector & terminal

(3E) No. 4 (+) — Chassis ground (-):

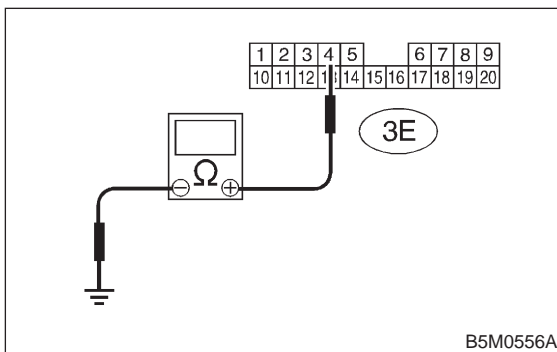

- CHECK** : Is the resistance more than 10 kΩ?  
**YES** : Go to step 5B4.  
**NO** : Go to step 5B4.

#### 5B4 : FRONT SUB SENSOR (LH) AND FRONT SUB SENSOR HARNESS (LH) INSPECTION

Measure resistance between test harness E connector (3E) terminal.

##### Connector & terminal

(3E) No. 1 — (3E) No. 3:

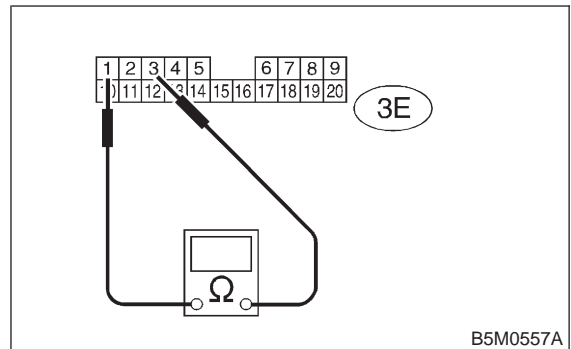

- CHECK** : Is the resistance between 750 Ω and 1 kΩ?  
**YES** : Go to step 5B5.  
**NO** : Go to step 5B5.

#### 5B5 : FRONT SUB SENSOR (LH) AND FRONT SUB SENSOR HARNESS (LH) INSPECTION

Measure resistance across test harness E connector (3E) terminal and chassis ground.

##### Connector & terminal

(3E) No. 1 (+) — Chassis ground (-):

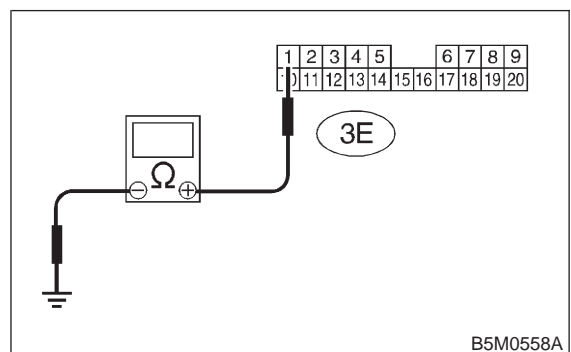

- CHECK** : Is the resistance more than 10 kΩ?  
**YES** : Go to step 5B6.  
**NO** : Go to step 5B6.

**5B6 : FRONT SUB SENSOR (LH) AND FRONT SUB SENSOR HARNESS (LH) INSPECTION**

Measure resistance across test harness E connector (3E) terminal and chassis ground.

**Connector & terminal**  
**(3E) No. 3 (+) — Chassis ground (-):**

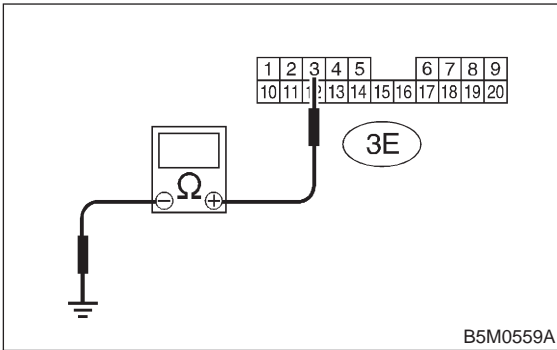

- CHECK** : Is the resistance more than 10 kΩ?
- YES** : Replace airbag control module. <Ref. to 5-5 [W5A0].>
- NO** : Go to step 5B7.

**5B7 : AIRBAG MAIN HARNESS INSPECTION**

- 1) Disconnect connector (AB14) and (AB15), then connect test harness F connector (2F) and connector (AB14).
- 2) Measure resistance between test harness E connector (3E) terminal and test harness F connector (3F) terminal.

**Connector & terminal**  
**(3E) No. 2 — (3F) No. 6:**

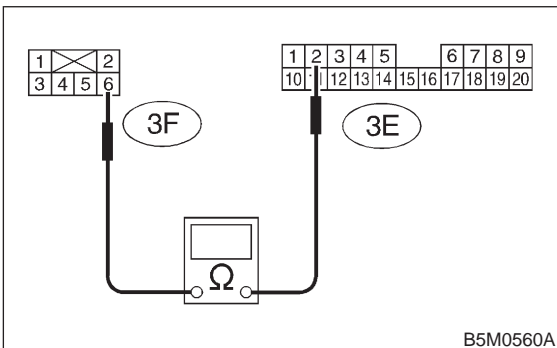

- CHECK** : Is the resistance less than 10 Ω?
- YES** : Go to step 5B8.
- NO** : Replace airbag main harness. <Ref. to 5-5 [W4A0].>

**5B8 : AIRBAG MAIN HARNESS INSPECTION**

Measure resistance between test harness E connector (3E) terminal and test harness F connector (3F) terminal.

**Connector & terminal**  
**(3E) No. 4 — (3F) No. 5:**

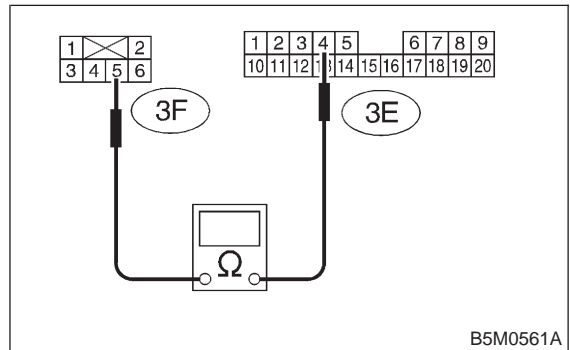

- CHECK** : Is the resistance less than 10 Ω?
- YES** : Go to step 5B9.
- NO** : Replace airbag main harness. <Ref. to 5-5 [W4A0].>

**5B9 : AIRBAG MAIN HARNESS INSPECTION**

Measure resistance across test harness E connector (3E) terminal and chassis ground.

**Connector & terminal**  
**(3E) No. 2 (+) — Chassis ground (-):**

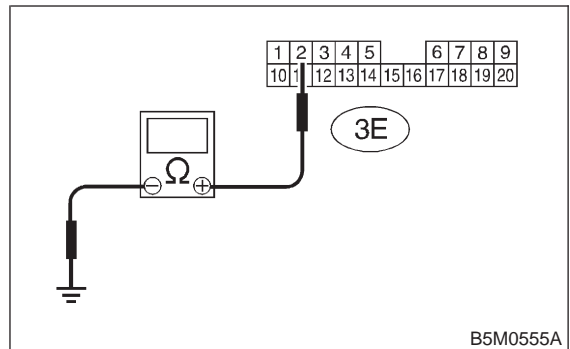

- CHECK** : Is the resistance more than 10 kΩ?
- YES** : Go to step 5B10.
- NO** : Replace airbag main harness. <Ref. to 5-5 [W4A0].>

## 5-5 [T5B10]

# SUPPLEMENTAL RESTRAINT SYSTEM

### 5. Diagnostics Chart with Trouble Code

#### 5B10 : AIRBAG MAIN HARNESS INSPECTION

Measure resistance across test harness E connector (3E) terminal and chassis ground.

##### Connector & terminal

(3E) No. 4 (+) — Chassis ground (-):

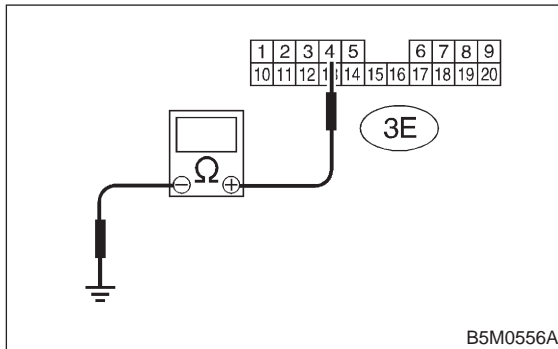

- CHECK** : Is the resistance more than 10 kΩ?  
**YES** : Go to step 5B11.  
**NO** : Replace airbag main harness. <Ref. to 5-5 [W4A0].>

#### 5B11 : FRONT SUB SENSOR HARNESS (RH) INSPECTION

- 1) Connect test harness F connector (1F) and connector (AB15).
- 2) Disconnect connector (AB16) from front sub sensor (RH) <Ref. to 5-5 [W7A0].> and then test harness H connector (1H) and connector (AB16).
- 3) Measure resistance between test harness F connector (3F) terminal and test harness H connector (3H) terminal.

##### Connector & terminal

(3F) No. 3 — (3H) No. 5:

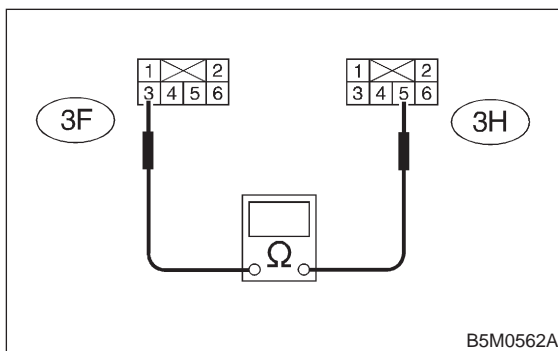

- CHECK** : Is the resistance less than 10 Ω?  
**YES** : Go to step 5B12.  
**NO** : Replace front sub sensor harness (RH). <Ref. to 5-5 [W7A0].>

#### 5B12 : FRONT SUB SENSOR HARNESS (RH) INSPECTION

Measure resistance between test harness F connector (3F) terminal and test harness H connector (3H) terminal.

##### Connector & terminal

(3F) No. 4 — (3H) No. 6:

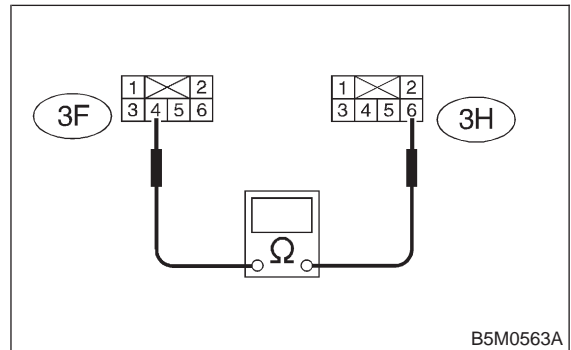

- CHECK** : Is the resistance less than 10 Ω?  
**YES** : Go to step 5B13.  
**NO** : Replace front sub sensor harness (RH). <Ref. to 5-5 [W7A0].>

#### 5B13 : FRONT SUB SENSOR HARNESS (RH) INSPECTION

Measure resistance across test harness F connector (3F) terminal and chassis ground.

##### Connector & terminal

(3F) No. 3 (+) — Chassis ground (-):

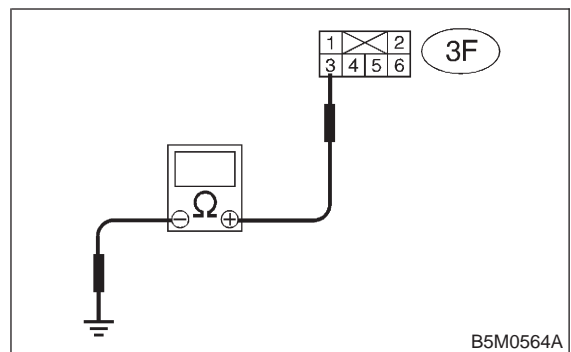

- CHECK** : Is the resistance more than 10 kΩ?  
**YES** : Go to step 5B14.  
**NO** : Replace front sub sensor harness (RH). <Ref. to 5-5 [W7A0].>

**5B14 : FRONT SUB SENSOR HARNESS (RH) INSPECTION**

Measure resistance across test harness F connector (3F) terminal and chassis ground.

**Connector & terminal**  
(3F) No. 4 (+) — Chassis ground (-):

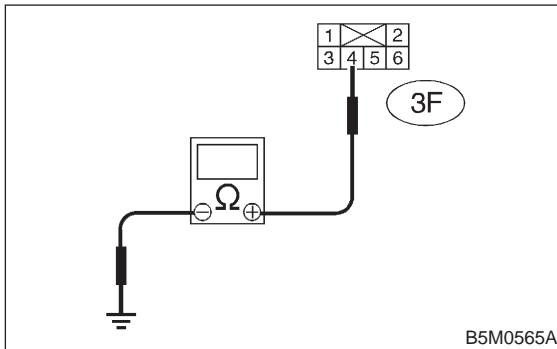

- CHECK** : Is the resistance more than 10 kΩ?
- YES** : Go to step 5B15.
- NO** : Replace front sub sensor harness (RH). <Ref. to 5-5 [W7A0].>

**5B15 : FRONT SUB SENSOR (RH) INSPECTION**

- 1) Connect test harness H connector (2H) and front sub sensor (RH).
- 2) Measure resistance between test harness H connector (3H) terminal.

**Connector & terminal**  
(3H) No. 3 — (3H) No. 4:

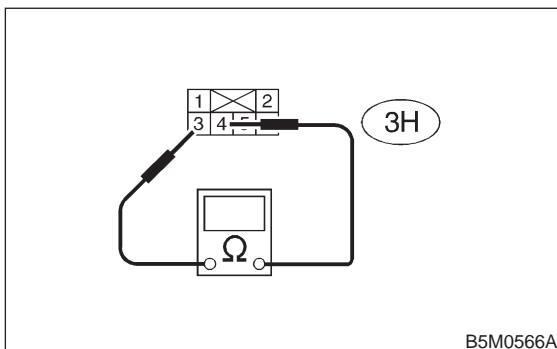

- CHECK** : Is the resistance between 750 Ω and 1 kΩ?
- YES** : Go to step 5B16.
- NO** : Replace front sub sensor (RH). <Ref. to 5-5 [W7A0].>

**5B16 : FRONT SUB SENSOR (RH) INSPECTION**

Measure resistance across test harness H connector (3H) terminal and chassis ground.

**Connector & terminal**  
(3H) No. 3 (+) — Chassis ground (-):

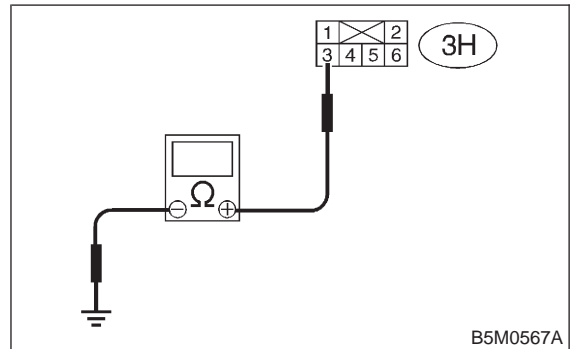

- CHECK** : Is the resistance more than 10 kΩ?
- YES** : Go to step 5B17.
- NO** : Replace front sub sensor (RH). <Ref. to 5-5 [W7A0].>

**5B17 : FRONT SUB SENSOR (RH) INSPECTION**

Measure resistance across test harness H connector (3H) terminal and chassis ground.

**Connector & terminal**  
(3H) No. 4 (+) — Chassis ground (-):

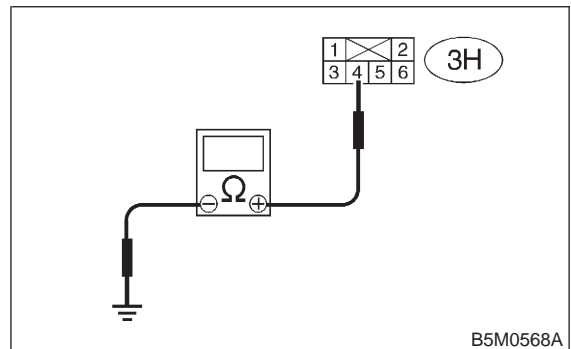

- CHECK** : Is the resistance more than 10 kΩ?
- YES** : Go to step 5B18.
- NO** : Replace front sub sensor (RH). <Ref. to 5-5 [W7A0].>

## 5-5 [T5B18]

# SUPPLEMENTAL RESTRAINT SYSTEM

### 5. Diagnostics Chart with Trouble Code

#### 5B18 : AIRBAG MAIN HARNESS INSPECTION

- 1) Disconnect connector (AB11) and (AB12), then connect test harness F connector (2F) and connector (AB11).
- 2) Measure resistance between test harness E connector (3E) terminal and test harness F connector (3F) terminal.

##### Connector & terminal

(3E) No. 3 — (3F) No. 6:

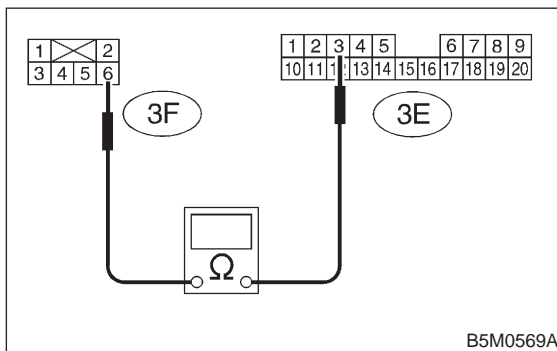

- CHECK** : Is the resistance less than 10 Ω?
- YES** : Go to step 5B19.
- NO** : Replace airbag main harness. <Ref. to 5-5 [W4A0].>

#### 5B19 : AIRBAG MAIN HARNESS INSPECTION

Measure resistance between test harness E connector (3E) terminal and test harness F connector (3F) terminal.

##### Connector & terminal

(3E) No. 1 — (3F) No. 5:

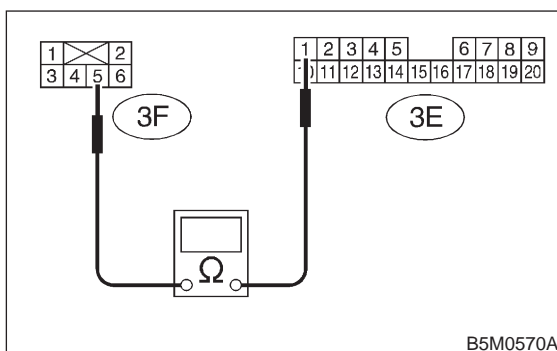

- CHECK** : Is the resistance less than 10 Ω?
- YES** : Go to step 5B20.
- NO** : Replace airbag main harness. <Ref. to 5-5 [W4A0].>

#### 5B20 : AIRBAG MAIN HARNESS INSPECTION

Measure resistance across test harness E connector (3E) terminal and chassis ground.

##### Connector & terminal

(3E) No. 3 (+) — Chassis ground (-):

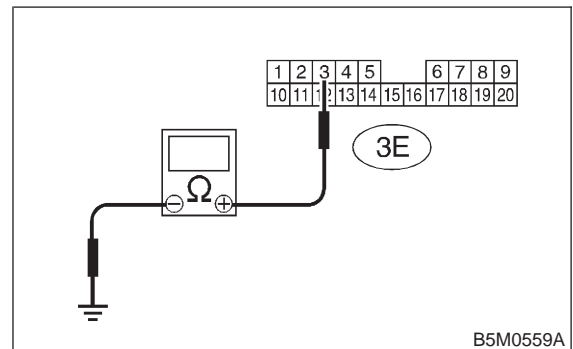

- CHECK** : Is the resistance more than 10 kΩ?
- YES** : Go to step 5B21.
- NO** : Replace airbag main harness. <Ref. to 5-5 [W4A0].>

#### 5B21 : AIRBAG MAIN HARNESS INSPECTION

Measure resistance across test harness E connector (3E) terminal and chassis ground.

##### Connector & terminal

(3E) No. 1 (+) — Chassis ground (-):

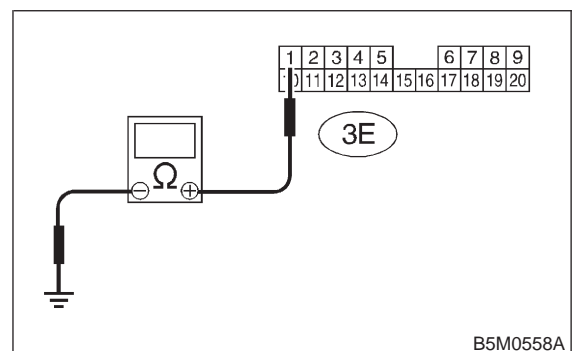

- CHECK** : Is the resistance more than 10 kΩ?
- YES** : Go to step 5B22.
- NO** : Replace airbag main harness. <Ref. to 5-5 [W4A0].>



**5B22 : FRONT SUB SENSOR HARNESS (LH) INSPECTION**

- 1) Connect test harness F connector (1F) and connector (AB12).
- 2) Disconnect connector (AB13) from front sub sensor (LH) <Ref. to 5-5 [W7A0].> and then test harness H connector (1H) and connector (AB13).
- 3) Measure resistance between test harness F connector (3F) terminal and test harness H connector (3H) terminal.

**Connector & terminal**  
**(3F) No. 3 — (3H) No. 5:**

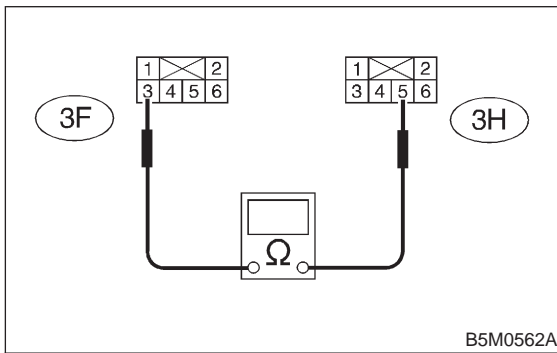

- CHECK** : *Is the resistance less than 10 Ω?*
- YES** : Go to step **5B23**.
- NO** : Replace front sub sensor harness (LH). <Ref. to 5-5 [W7A0].>

**5B23 : FRONT SUB SENSOR HARNESS (LH) INSPECTION**

Measure resistance between test harness F connector (3F) terminal and test harness H connector (3H) terminal.

**Connector & terminal**  
**(3F) No. 4 — (3H) No. 6:**

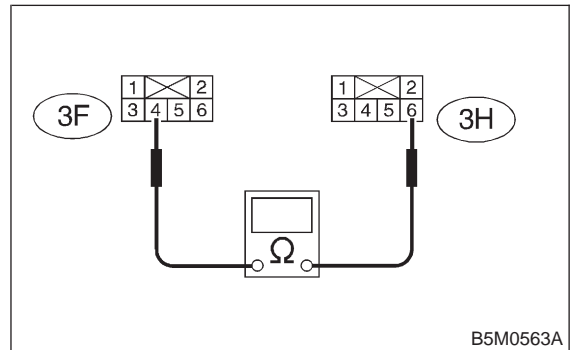

- CHECK** : *Is the resistance less than 10 Ω?*
- YES** : Go to step **5B24**.
- NO** : Replace front sub sensor harness (LH). <Ref. to 5-5 [W7A0].>

**5B24 : FRONT SUB SENSOR HARNESS (LH) INSPECTION**

Measure resistance across test harness F connector (3F) terminal and chassis ground.

**Connector & terminal**  
**(3F) No. 3 (+) — Chassis ground (-):**

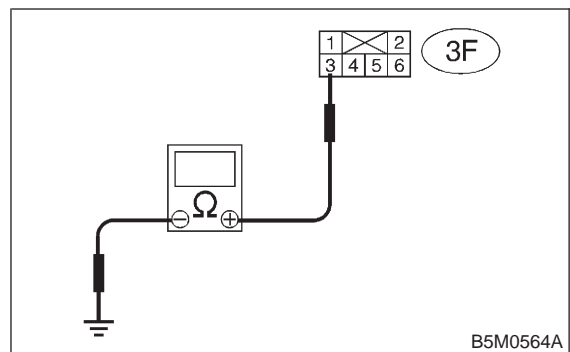

- CHECK** : *Is the resistance more than 10 kΩ?*
- YES** : Go to step **5B25**.
- NO** : Replace front sub sensor harness (LH). <Ref. to 5-5 [W7A0].>

## 5-5 [T5B25]

# SUPPLEMENTAL RESTRAINT SYSTEM

### 5. Diagnostics Chart with Trouble Code

#### 5B25 : FRONT SUB SENSOR HARNESS (LH) INSPECTION

Measure resistance across test harness F connector (3F) terminal and chassis ground.

##### Connector & terminal

(3F) No. 4 (+) — Chassis ground (-):

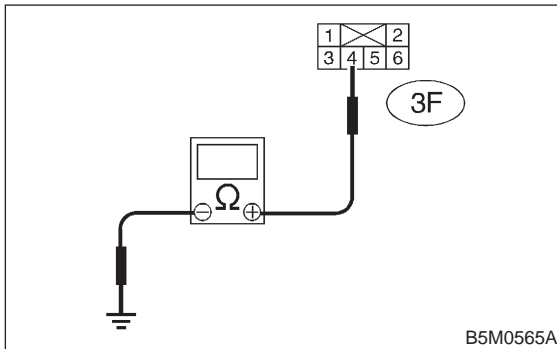

- CHECK** : Is the resistance more than 10 k $\Omega$ ?  
**YES** : Go to step 5B26.  
**NO** : Replace front sub sensor harness (LH). <Ref. to 5-5 [W7A0].>

#### 5B26 : FRONT SUB SENSOR (LH) INSPECTION

- 1) Connect test harness H connector (2H) and front sub sensor (LH).
- 2) Measure resistance between test harness H connector (3H) terminal.

##### Connector & terminal

(3H) No. 3 — (3H) No. 4:

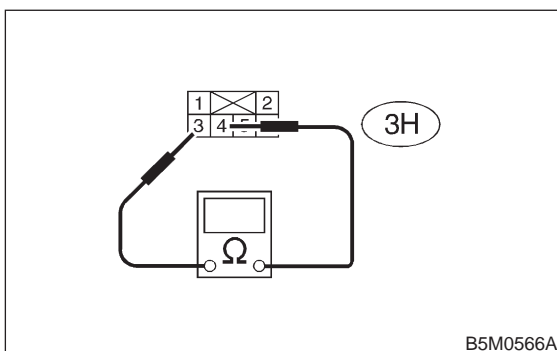

- CHECK** : Is the resistance between 750  $\Omega$  and 1 k $\Omega$ ?  
**YES** : Go to step 5B27.  
**NO** : Replace front sub sensor (LH). <Ref. to 5-5 [W7A0].>

#### 5B27 : FRONT SUB SENSOR (LH) INSPECTION

Measure resistance across test harness H connector (3H) terminal and chassis ground.

##### Connector & terminal

(3H) No. 3 (+) — Chassis ground (-):

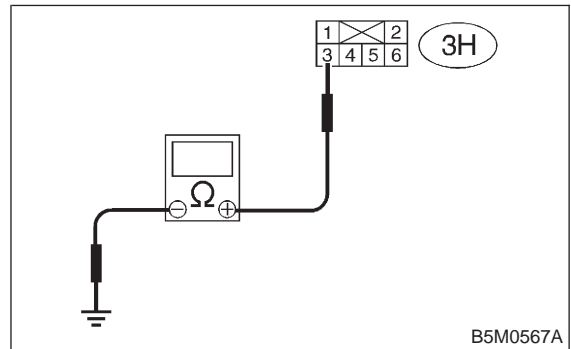

- CHECK** : Is the resistance more than 10 k $\Omega$ ?  
**YES** : Go to step 5B28.  
**NO** : Replace front sub sensor (LH). <Ref. to 5-5 [W7A0].>

#### 5B28 : FRONT SUB SENSOR (LH) INSPECTION

Measure resistance across test harness H connector (3H) terminal and chassis ground.

##### Connector & terminal

(3H) No. 4 (+) — Chassis ground (-):

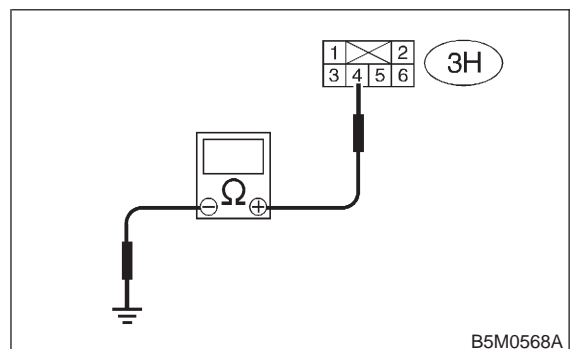

- CHECK** : Is the resistance more than 10 k $\Omega$ ?  
**YES** : Perform clear memory. <Ref. to 5-5 [T4C0].>  
**NO** : Replace front sub sensor (LH). <Ref. to 5-5 [W7A0].>

**C: TROUBLE CODE 04**

**DIAGNOSIS:**

- Airbag main harness circuit is shorted.
- Passenger's airbag module harness circuit is shorted.
- Airbag control module is faulty.

**CAUTION:**

Before performing diagnostics on airbag system, turn ignition switch "OFF", disconnect battery ground cable and then wait at least 20 seconds.

After 20 seconds elapse, remove instrument panel lower cover, and disconnect (AB3) and (AB8), (AB9) and (AB10).

**5C1 : AIRBAG MAIN HARNESS INSPECTION**

- 1) Disconnect connector (AB6) from airbag control module <Ref. to 5-5 [W5A0].>, and connect it to test harness E connector (1E).
- 2) Measure resistance between test harness E connector (2E) terminal.

**Connector & terminal**

**(2E) No. 2 — (2E) No. 5:**

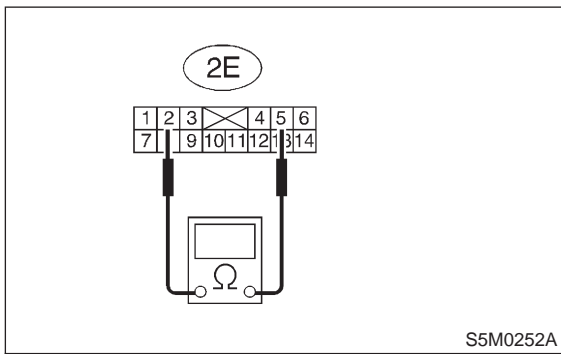

- CHECK** : Is resistance more than 10 kΩ?
- YES** : Replace airbag control module. <Ref. to 5-5 [W5A0].>
- NO** : Replace airbag main harness. <Ref. to 5-5 [W4A0].>

**D: TROUBLE CODE 08**

**DIAGNOSIS:**

- Airbag control module is faulty.
- Airbag main harness is faulty.

**CAUTION:**

Before performing diagnostics on airbag system, turn ignition switch OFF, disconnect battery ground cable and then wait at least 20 seconds.

After 20 seconds elapse, remove instrument panel lower cover, and disconnect (AB3) and (AB8), (AB9) and (AB10).

**5D1 : AIRBAG MAIN HARNESS INSPECTION**

- 1) Disconnect connector (AB18) from airbag control module and connect it to test harness E connector (1E).
- 2) Connect battery ground cable and turn ignition switch ON. (engine off)
- 3) Measure voltage across connector (3E) terminal and chassis ground.

**Connector & terminal**

**(3E) No. 7 (+) — Chassis ground (-):**

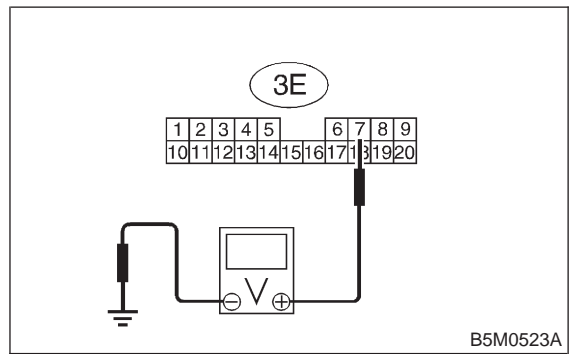

- CHECK** : Is the voltage less than 1 V?
- YES** : Replace airbag control module. <Ref. to 5-5 [W5A0].>
- NO** : Go to step 5D2.

## 5-5 [T5D2]

# SUPPLEMENTAL RESTRAINT SYSTEM

## 5. Diagnostics Chart with Trouble Code

### 5D2 : AIRBAG MAIN HARNESS INSPECTION

Measure voltage across connector (3E) terminal and chassis ground.

#### Connector & terminal

(3E) No. 8 (+) — Chassis ground (-):

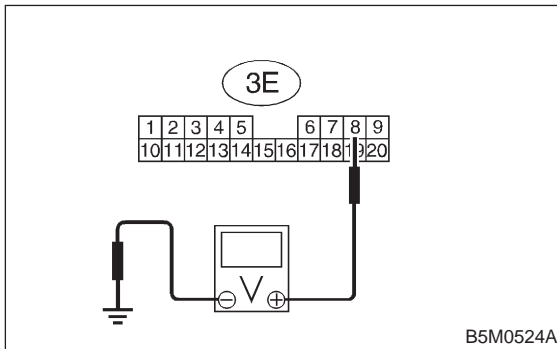

- CHECK** : Is the voltage less than 1 V?
- YES** : Replace airbag control module. <Ref. to 5-5 [W5A0].>
- NO** : Replace airbag main harness. <Ref. to 5-5 [W4A0].>

### E: TROUBLE CODE 09

#### DIAGNOSIS:

- Airbag control module is faulty.
- Airbag main harness is faulty.

#### CAUTION:

Before performing diagnostics on airbag system, turn ignition switch OFF, disconnect battery ground cable and then wait at least 20 seconds.

After 20 seconds elapse, remove instrument panel lower cover, and disconnect (AB3) and (AB8), (AB9) and (AB10).

### 5E1 : AIRBAG MAIN HARNESS INSPECTION

- 1) Disconnect connector (AB17) from airbag control module and connect it to test harness E connector (1E).
- 2) Connect battery ground cable and turn ignition switch ON. (engine off)
- 3) Measure voltage across connector (3E) terminal and chassis ground.

#### Connector & terminal

(3E) No. 10 (+) — Chassis ground (-):

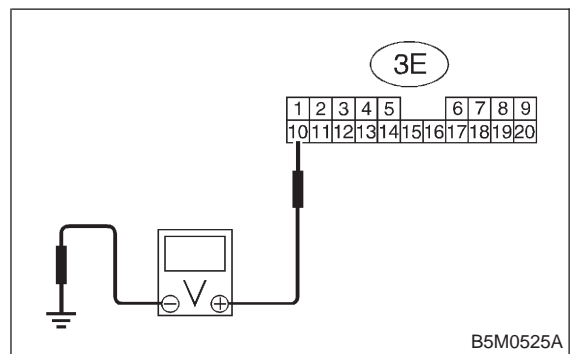

- CHECK** : Is the voltage less than 1 V?
- YES** : Replace airbag control module. <Ref. to 5-5 [W5A0].>
- NO** : Go to step 5E2.

**5E2 : AIRBAG MAIN HARNESS INSPECTION**

Measure voltage across connector (3E) terminal and chassis ground.

**Connector & terminal**  
**(3E) No. 12 (+) — Chassis ground (-):**

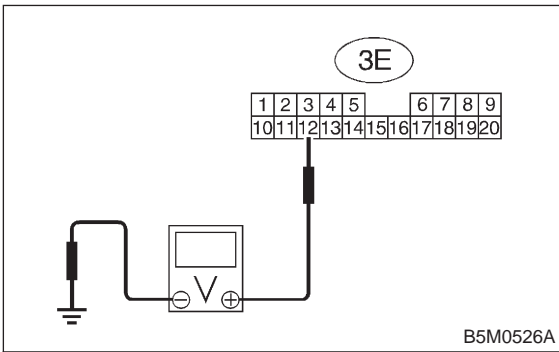

- CHECK** : **Is the voltage less than 1 V?**
- YES** : Replace airbag control module. <Ref. to 5-5 [W5A0].>
- NO** : Replace airbag main harness. <Ref. to 5-5 [W4A0].>

**F: TROUBLE CODE 11**

**DIAGNOSIS:**

- Airbag control module is faulty.
- Airbag main harness circuit is open.
- Fuse No. 8 is blown. (In joint box)
- Body harness circuit is open.

**CAUTION:**

**Before performing diagnostics on airbag system, turn ignition switch “OFF”, disconnect battery ground cable and then wait at least 20 seconds.**

**After 20 seconds elapse, remove instrument panel lower cover, and disconnect (AB3) and (AB8), (AB9) and (AB10).**

**5F1 : AIRBAG CONTROL MODULE INSPECTION**

- 1) Disconnect connector (AB6) from airbag control module <Ref. to 5-5 [W5A0].> and connect it to test harness E connector (1E).
- 2) Connect battery ground cable and turn ignition switch “ON”. (engine off)
- 3) Measure voltage across connector (2E) terminal and chassis ground.

**Connector & terminal**

**(2E) No. 6 (+) — Chassis ground (-):**

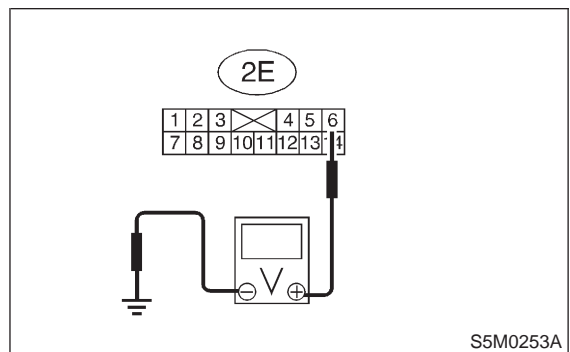

- CHECK** : **Is voltage more than 10 V?**
- YES** : Replace airbag control module. <Ref. to 5-5 [W5A0].>
- NO** : Go to step **5F2**.

## 5-5 [T5F2]

# SUPPLEMENTAL RESTRAINT SYSTEM

## 5. Diagnostics Chart with Trouble Code

### 5F2 : AIRBAG MAIN HARNESS INSPECTION

1) Go to following procedure after performing diagnostics on airbag system as per diagnosis procedure under "5F1: AIRBAG CONTROL MODULE INSPECTION" <Ref. to 5-5 [T5F1].> previously outlined.

2) Turn ignition switch "OFF", disconnect battery ground terminal and then wait at least 20 seconds.

3) Disconnect body harness connector (B31) from connector (AB1) at front lower pillar, and connect connector (AB1) to test harness A connector (2A).

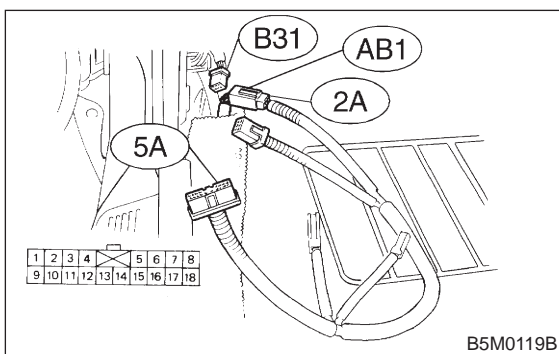

4) Measure resistance between test harness A connector (5A) terminal and test harness E connector (2E) terminal.

#### Connector & terminal

(5A) No. 1 — (2E) No. 6:

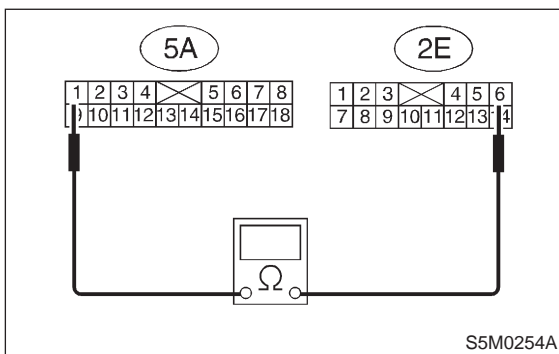

**CHECK** : Is resistance less than 10 Ω?

**YES** : Go to step 5F3.

**NO** : Replace airbag main harness. <Ref. to 5-5 [W4A0].>

### 5F3 : AIRBAG MAIN HARNESS INSPECTION

Measure resistance between (5A) connector terminal and chassis ground.

#### Connector & terminal

(5A) No. 1 (+) — Chassis ground (-):

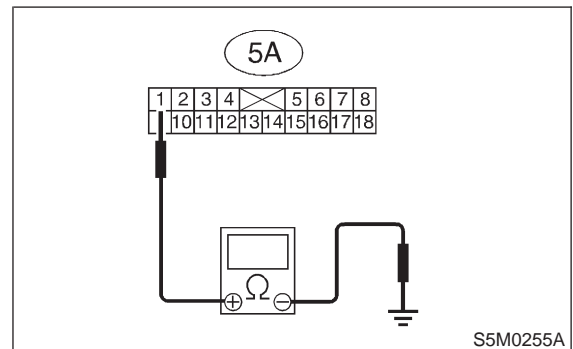

**CHECK** : Is resistance more than 10 kΩ?

**YES** : Go to step 5F4.

**NO** : Replace airbag main harness. <Ref. to 5-5 [W4A0].>

### 5F4 : AIRBAG MAIN HARNESS INSPECTION

Measure resistance between (2E) connector terminal and chassis ground.

#### Connector & terminal

(2E) No. 6 (+) — Chassis ground (-):

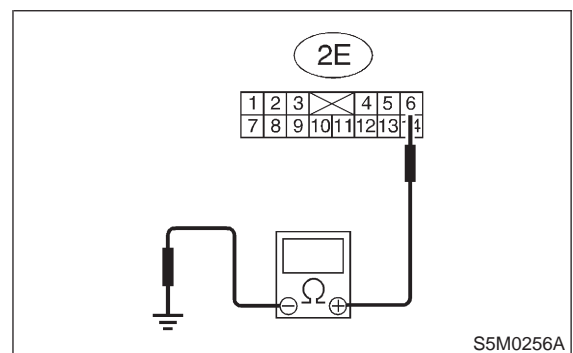

**CHECK** : Is resistance more than 10 kΩ?

**YES** : Go to step 5F5.

**NO** : Replace airbag main harness. <Ref. to 5-5 [W4A0].>

**5F5 : FUSE NO. 8 (IN JOINT BOX) INSPECTION**

- 1) Turn ignition switch "OFF".
- 2) Remove and visually check fuse No. 8 (in joint box).

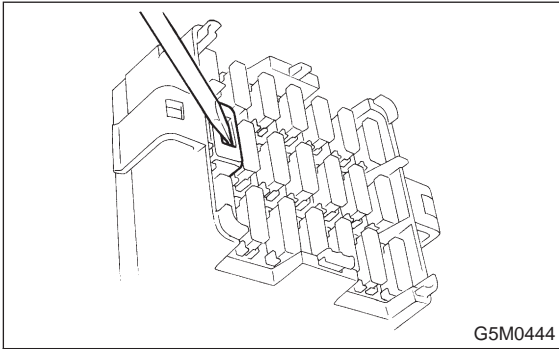

- CHECK** : *Is fuse No. 8 blown?*
- YES** : Replace fuse No. 8 if fuse No. 8 blows again, repair body harness.
- NO** : Repair body harness.

**G: TROUBLE CODE 12**

**DIAGNOSIS:**

- Airbag main harness circuit is open.
- Driver's airbag module harness circuit is open.
- Roll connector circuit is open.
- Airbag control module is faulty.

**CAUTION:**

**Before performing diagnostics on airbag system, turn ignition switch "OFF", disconnect battery ground cable and then wait at least 20 seconds.**

**5G1 : AIRBAG MAIN HARNESS INSPECTION**

- 1) Remove lower cover panel <Ref. to 5-4 [W1A0].>, and connect connector (AB8) below steering column to test harness F connector (1F).

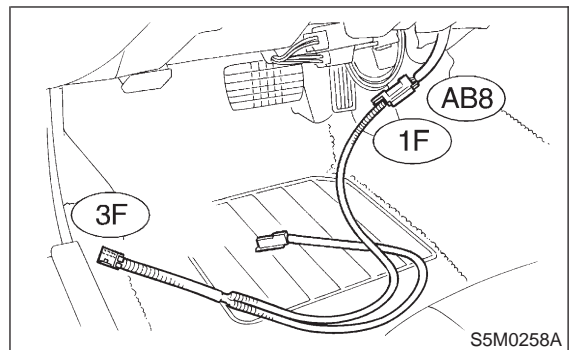

- 2) Disconnect connector (AB6) <Ref. to 5-5 [W5A0].> from airbag control module, and connect it to test harness E connector (1E) terminal.
- 3) Measure resistance between test harness E connector (2E) and test harness F connector (3F) terminals.

**Connector & terminal**

**(2E) No. 1 — (3F) No. 3:**

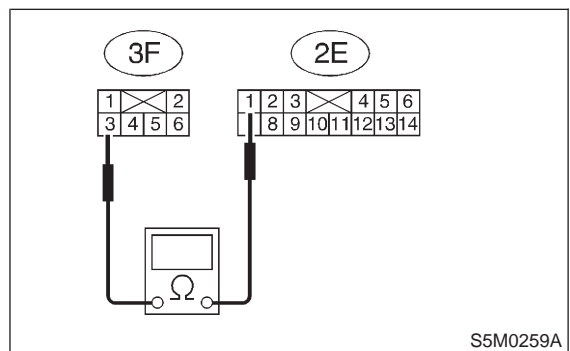

- CHECK** : *Is resistance less than 10 Ω?*
- YES** : Go to step 5G2.
- NO** : Replace airbag main harness. <Ref. to 5-5 [W4A0].>

## 5-5 [T5G2]

# SUPPLEMENTAL RESTRAINT SYSTEM

## 5. Diagnostics Chart with Trouble Code

### 5G2 : AIRBAG MAIN HARNESS INSPECTION

Measure resistance between test harness E connector (2E) and test harness F connector (3F) terminals.

#### Connector & terminal

(2E) No. 4 — (3F) No. 4:

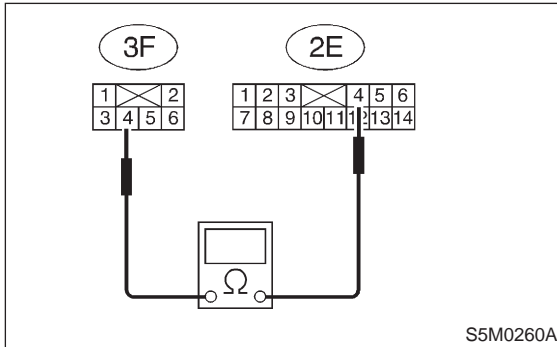

**CHECK** : Is resistance less than 10 Ω?

**YES** : Replace airbag control module. <Ref. to 5-5 [W5A0].>

**NO** : Replace airbag main harness. <Ref. to 5-5 [W4A0].>

### H: TROUBLE CODE 13

#### DIAGNOSIS:

- Airbag main harness circuit is shorted.
- Driver's airbag module harness is shorted.
- Roll connector circuit is shorted.
- Airbag control module is faulty.

#### CAUTION:

Before performing diagnostics on airbag system, turn ignition switch "OFF", disconnect battery ground cable and then wait at least 20 seconds.

After 20 seconds elapse, remove instrument panel lower cover, and disconnect (AB3) and (AB8), (AB9) and (AB10).

### 5H1 : AIRBAG MAIN HARNESS INSPECTION

1) Disconnect connector (AB6) from airbag control module <Ref. to 5-5 [W5A0].>, and connect it to test harness E connector (1E).

2) Measure resistance between test harness E connector (2E) terminal.

#### Connector & terminal

(2E) No. 1 — (2E) No. 4:

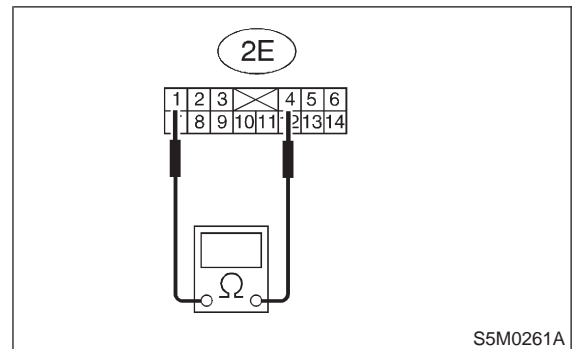

**CHECK** : Is resistance more than 10 kΩ?

**YES** : Replace airbag control module. <Ref. to 5-5 [W5A0].>

**NO** : Replace airbag main harness. <Ref. to 5-5 [W4A0].>



**I: TROUBLE CODE 14**

**DIAGNOSIS:**

(AB6), (AB17) and (AB18) are not connected properly to airbag control module.

**CAUTION:**

Before performing diagnostics on airbag system, turn ignition switch "OFF", disconnect battery ground cable and then wait at least 20 seconds.

**5I1 : CHECK POOR CONTACT IN CONNECTORS (AB6), (AB17) AND (AB18).**

Check connectors (AB6), (AB17) and (AB18) connected to airbag control module. <Ref. to 5-5 [W5A0].>

- CHECK** : *Is there poor contact in connectors (AB6), (AB17) and (AB18)?*
- YES** : Repair poor contact in connectors (AB6), (AB17) and (AB18).
- NO** : Replace airbag control module. <Ref. to 5-5 [W5A0].>

**J: TROUBLE CODE 15**

**DIAGNOSIS:**

- Side airbag sensor (RH) is faulty.
- Airbag main harness is faulty.

**CAUTION:**

Before performing diagnostics on airbag system, turn ignition switch OFF, disconnect battery ground cable and then wait at least 20 seconds.

After 20 seconds elapse, remove instrument panel lower cover, and disconnect (AB3) and (AB8), (AB9) and (AB10).

**5J1 : AIRBAG MAIN HARNESS INSPECTION**

- 1) Disconnect connector (AB18) from airbag control module and connect it to test harness E connector (1E).
- 2) Disconnect connector (AB28) from airbag control module and connect it to test harness G connector (1G).
- 3) Measure resistance between test harness E connector (3E) terminal and test harness G connector (3G) terminal.

**Connector & terminal**  
**(3E) No. 17 — (3G) No. 2:**

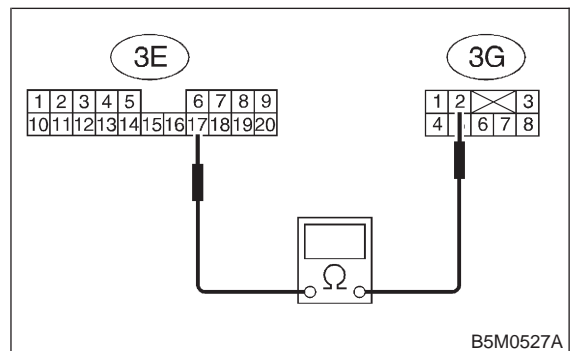

- CHECK** : *Is the resistance less than 10 Ω?*
- YES** : Go to step 5J2.
- NO** : Replace airbag main harness. <Ref. to 5-5 [W4A0].>

## 5-5 [T5J2]

# SUPPLEMENTAL RESTRAINT SYSTEM

## 5. Diagnostics Chart with Trouble Code

### 5J2 : AIRBAG MAIN HARNESS INSPECTION

Measure resistance between test harness E connector (3E) terminal and test harness G connector (3G) terminal.

**Connector & terminal**  
**(3E) No. 19 — (3G) No. 5:**

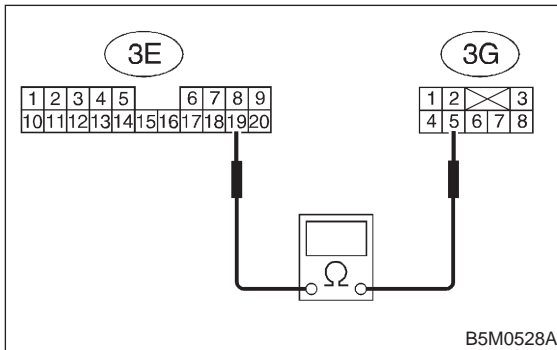

- CHECK** : Is the resistance less than 10 Ω?
- YES** : Go to step 5J3.
- NO** : Replace airbag main harness. <Ref. to 5-5 [W4A0].>

### 5J3 : AIRBAG MAIN HARNESS INSPECTION

Measure resistance between connector (3G) terminal and chassis ground.

**Connector & terminal**  
**(3G) No. 2 (+) — Chassis ground (-):**

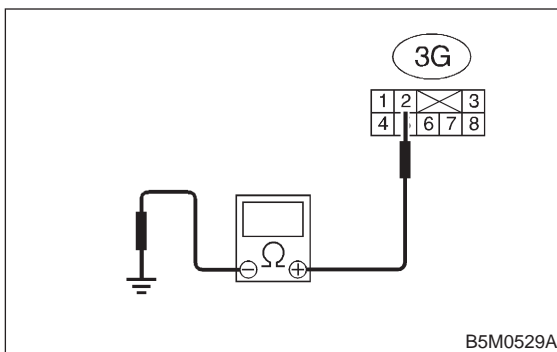

- CHECK** : Is the resistance more than 1 MΩ?
- YES** : Go to step 5J4.
- NO** : Replace airbag main harness. <Ref. to 5-5 [W4A0].>

### 5J4 : AIRBAG MAIN HARNESS INSPECTION

Measure resistance between connector (3G) terminal and chassis ground.

**Connector & terminal**  
**(3G) No. 5 (+) — Chassis ground (-):**

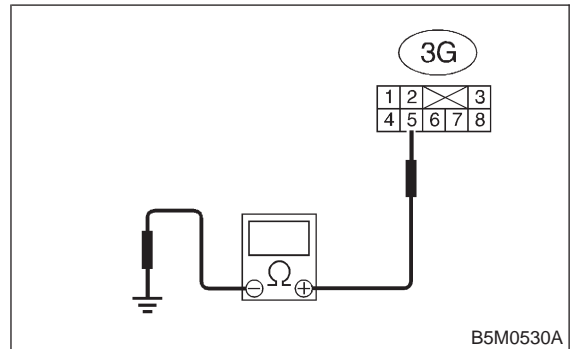

- CHECK** : Is the resistance more than 1 MΩ?
- YES** : Go to step 5J5.
- NO** : Replace airbag main harness. <Ref. to 5-5 [W4A0].>

### 5J5 : AIRBAG MAIN HARNESS INSPECTION

Measure resistance between connector (3E) terminal and chassis ground.

**Connector & terminal**  
**(3E) No. 17 (+) — Chassis ground (-):**

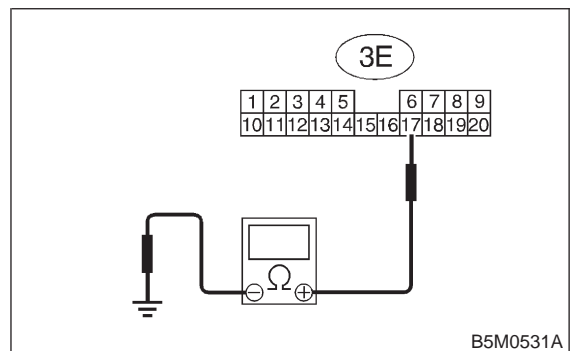

- CHECK** : Is the resistance more than 1 MΩ?
- YES** : Go to step 5J6.
- NO** : Replace airbag main harness. <Ref. to 5-5 [W4A0].>

**5J6 : AIRBAG MAIN HARNESS INSPECTION**

Measure resistance between connector (3E) terminal and chassis ground.

**Connector & terminal**  
**(3E) No. 19 (+) — Chassis ground (-):**

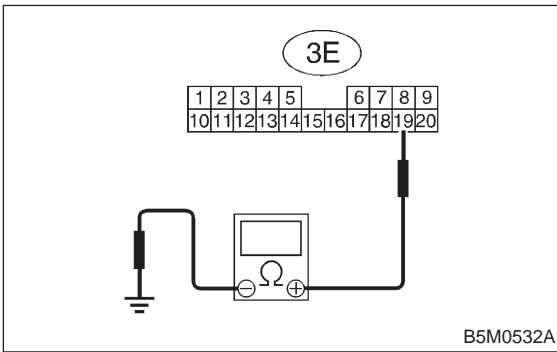

- CHECK** : **Is the resistance more than 1 MΩ?**
- YES** : Replace airbag main sensor. <Ref. to 5-5 [W8A0].>
- NO** : Replace airbag main harness. <Ref. to 5-5 [W4A0].>

**K: TROUBLE CODE 16**

**DIAGNOSIS:**

- Side airbag sensor (RH) is faulty.
- Side airbag sensor is different.

**CAUTION:**

**Before performing diagnostics on airbag system, turn ignition switch OFF, disconnect battery ground cable and then wait at least 20 seconds.**

**5K1 : CHECK IF TROUBLE CODE 16 IS INDICATED.**

Confirm flashing trouble code according to "BASIC DIAGNOSTICS PROCEDURE". <Ref. to 5-5 [T4A0].>

- CHECK** : **Is airbag warning light trouble code 16 indicated?**
- YES** : Replace side airbag sensor (RH). <Ref. to 5-5 [W8A0].>
- NO** : Perform clear memory. <Ref. to 5-5 [T4C0].>

**L: TROUBLE CODE 21****DIAGNOSIS:**

Airbag control module is faulty.

**CAUTION:**

Before performing diagnostics on airbag system, turn ignition switch "OFF", disconnect battery ground terminal, and then wait at least 20 seconds. <Ref. to 5-5 [W5A0].>

**5L1 : CHECK IF TROUBLE CODE 21 IS INDICATED.**

Confirm flashing trouble code according to "BASIC DIAGNOSTICS PROCEDURE". <Ref. to 5-5 [T4A0].>

- CHECK** : *Is airbag warning light trouble code 21 indicated?*
- YES** : Replace airbag control module. <Ref. to 5-5 [W5A0].>
- NO** : Perform clear memory. <Ref. to 5-5 [T4C0].>

**M: TROUBLE CODE 22****DIAGNOSIS:**

- Airbag main harness circuit is open.
- Passenger's airbag module harness circuit is open.
- Airbag control module is faulty.

**CAUTION:**

Before performing diagnostics on airbag system, turn ignition switch "OFF", disconnect battery ground cable and then wait at least 20 seconds.

**5M1 : AIRBAG MAIN HARNESS INSPECTION**

- 1) Remove front pillar lower trim (Passenger side). <Ref. to 5-3 [W5A1].>
- 2) Disconnect connector (AB9) and (AB10) <Ref. to 5-5 [W3A2].> and connect connector (AB9) to test harness F connector (1F).
- 3) Disconnect connector (AB6) <Ref. to 5-5 [W5A0].> from airbag control module, and connect it to test harness E connector (1E) terminal.
- 4) Measure resistance between test harness E connector (2E) and test harness F connector (3F) terminals.

**Connector & terminal**

**(2E) No. 2 — (3F) No. 3:**

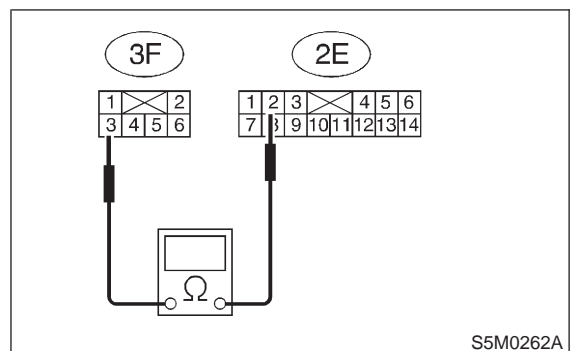

- CHECK** : *Is resistance less than 10 Ω?*
- YES** : Go to step **5M2**.
- NO** : Replace airbag main harness. <Ref. to 5-5 [W4A0].>

**5M2 : AIRBAG MAIN HARNESS INSPECTION**

Measure resistance between test harness E connector (2E) and test harness F connector (3F) terminals.

**Connector & terminal**  
(2E) No. 5 — (3F) No. 4:

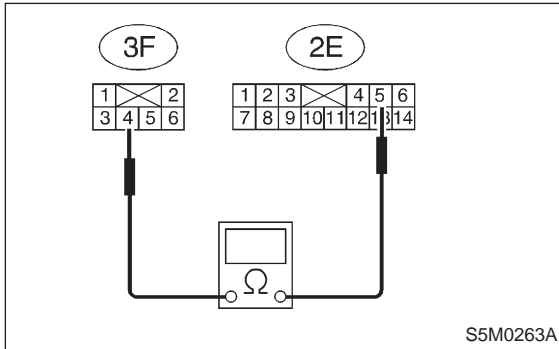

- CHECK** : Is resistance less than 10 Ω?
- YES** : Replace airbag control module. <Ref. to 5-5 [W5A0].>
- NO** : Replace airbag main harness. <Ref. to 5-5 [W4A0].>

**N: TROUBLE CODE 25**

**DIAGNOSIS:**

- Side airbag sensor (LH) is faulty.
- Airbag main harness is faulty.

**CAUTION:**

Before performing diagnostics on airbag system, turn ignition switch OFF, disconnect battery ground cable and then wait at least 20 seconds.

After 20 seconds elapse, remove instrument panel lower cover, and disconnect (AB3) and (AB8), (AB9) and (AB10).

**5N1 : AIRBAG MAIN HARNESS INSPECTION**

- 1) Disconnect connector (AB17) from airbag control module and connect it to test harness E connector (1E).
- 2) Disconnect connector (AB23) from airbag control module and connect it to test harness G connector (1G).
- 3) Measure resistance between test harness E connector (3E) terminal and test harness G connector (3G) terminal.

**Connector & terminal**  
(3E) No. 14 — (3G) No. 5:

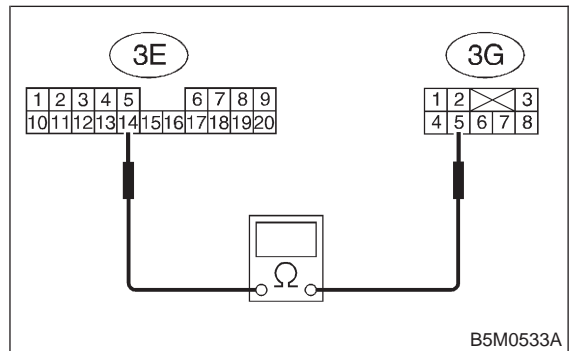

- CHECK** : Is the resistance less than 10 Ω?
- YES** : Go to step 5N2.
- NO** : Replace airbag main harness. <Ref. to 5-5 [W4A0].>

## 5-5 [T5N2]

# SUPPLEMENTAL RESTRAINT SYSTEM

### 5. Diagnostics Chart with Trouble Code

#### 5N2 : AIRBAG MAIN HARNESS INSPECTION

Measure resistance between test harness E connector (3E) terminal and test harness G connector (3G) terminal.

**Connector & terminal**  
**(3E) No. 16 — (3G) No. 2:**

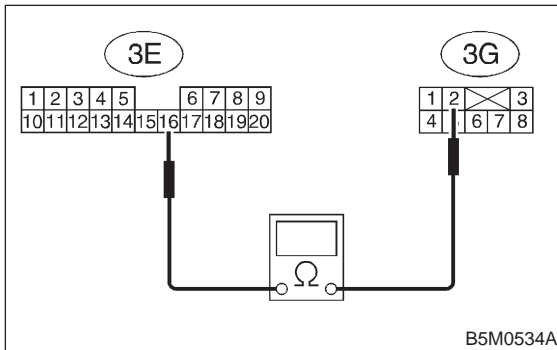

- CHECK** : Is the resistance less than 10 Ω?
- YES** : Go to step 5N3.
- NO** : Replace airbag main harness. <Ref. to 5-5 [W4A0].>

#### 5N3 : AIRBAG MAIN HARNESS INSPECTION

Measure resistance between connector (3G) terminal and chassis ground.

**Connector & terminal**  
**(3G) No. 2 (+) — Chassis ground (-):**

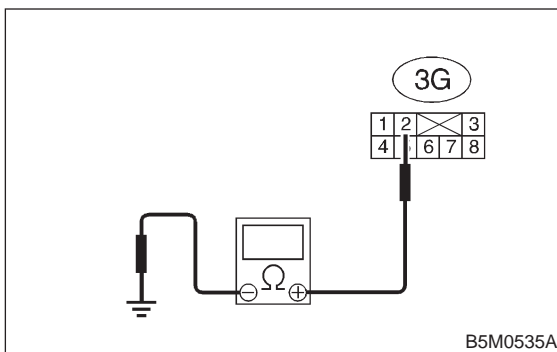

- CHECK** : Is the resistance more than 1 MΩ?
- YES** : Go to step 5N4.
- NO** : Replace airbag main harness. <Ref. to 5-5 [W4A0].>

#### 5N4 : AIRBAG MAIN HARNESS INSPECTION

Measure resistance between connector (3G) terminal and chassis ground.

**Connector & terminal**  
**(3G) No. 5 (+) — Chassis ground (-):**

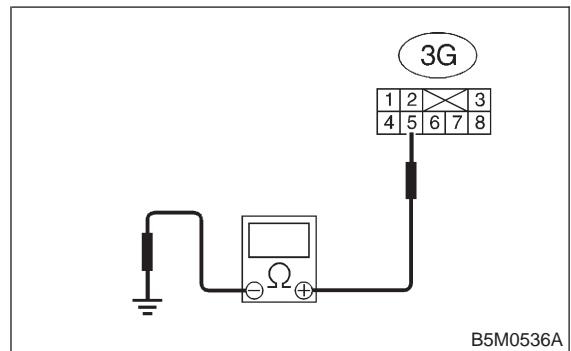

- CHECK** : Is the resistance more than 1 MΩ?
- YES** : Go to step 5N5.
- NO** : Replace airbag main harness. <Ref. to 5-5 [W4A0].>

#### 5N5 : AIRBAG MAIN HARNESS INSPECTION

Measure resistance between connector (3E) terminal and chassis ground.

**Connector & terminal**  
**(3E) No. 14 (+) — Chassis ground (-):**

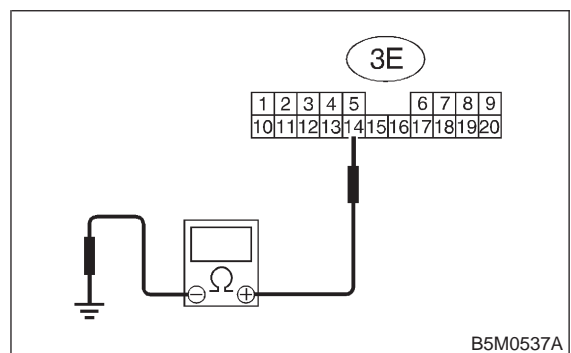

- CHECK** : Is the resistance more than 1 MΩ?
- YES** : Go to step 5N6.
- NO** : Replace airbag main harness. <Ref. to 5-5 [W4A0].>

**5N6 : AIRBAG MAIN HARNESS INSPECTION**

Measure resistance between connector (3E) terminal and chassis ground.

**Connector & terminal**  
**(3E) No. 16 (+) — Chassis ground (-):**

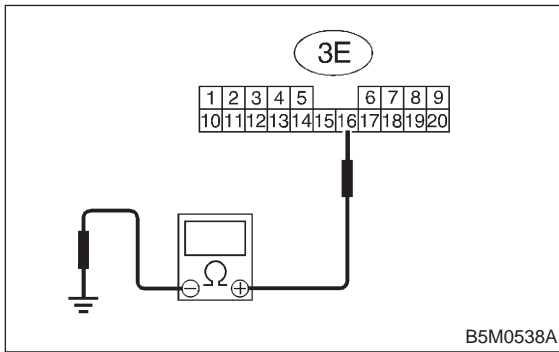

- CHECK** : **Is the resistance more than 1 MΩ?**
- YES** : Replace side airbag sensor (LH). <Ref. to 5-5 [W8A0].>
- NO** : Replace airbag main harness. <Ref. to 5-5 [W4A0].>

**O: TROUBLE CODE 26**

**DIAGNOSIS:**

- Side airbag sensor (LH) is faulty.
- Side airbag sensor is different.

**CAUTION:**

**Before performing diagnostics on airbag system, turn ignition switch OFF, disconnect battery ground cable and then wait at least 20 seconds.**

**5O1 : CHECK IF TROUBLE CODE 26 IS INDICATED.**

Confirm flashing trouble code according to "BASIC DIAGNOSTICS PROCEDURE". <Ref. to 5-5 [T4A0].>

- CHECK** : **Is airbag warning light trouble code 26 indicated?**
- YES** : Replace side airbag sensor (LH). <Ref. to 5-5 [W8A0].>
- NO** : Perform clear memory. <Ref. to 5-5 [T4C0].>

**P: TROUBLE CODE 31**

**DIAGNOSIS:**

- Airbag control module is faulty.
- Airbag main harness circuit is open.
- Fuse No. 16 is blown. (In joint box)
- Body harness circuit is open.

**CAUTION:**

**Before performing diagnostics on airbag system, turn ignition switch “OFF”, disconnect battery ground cable and then wait at least 20 seconds.**

**After 20 seconds elapse, remove instrument panel lower cover, and disconnect (AB3) and (AB8), (AB9) and (AB10).**

**5P1 : AIRBAG CONTROL MODULE INSPECTION**

- 1) Disconnect connector (AB6) from airbag control module <Ref. to 5-5 [W5A0].>, and connect it to test harness E connector (1E).
- 2) Connect battery ground cable and turn ignition switch “ON” (engine off).
- 3) Measure voltage across connector (2E) terminal and chassis ground.

**Connector & terminal**

**(2E) No. 3 (+) — Chassis ground (-):**

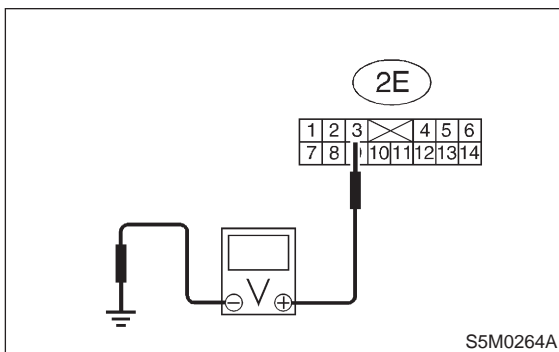

- CHECK** : Is voltage more than 10 V?
- YES** : Replace airbag control module. <Ref. to 5-5 [W5A0].>
- NO** : Go to step 5P2.

**5P2 : AIRBAG MAIN HARNESS INSPECTION**

- 1) Go to following procedure after performing diagnostics on airbag system as per diagnosis procedure under “5P1 AIRBAG CONTROL MODULE INSPECTION” <Ref. to 5-5 [T5P1].> previously outlined.
- 2) Turn ignition switch “OFF”, disconnect battery ground cable and then wait at least 20 seconds.
- 3) Disconnect connector (AB1) from body harness connector (B31) at front lower pillar (driver side), and connect connector (AB1) to test harness A connector (2A).
- 4) Measure resistance between test harness A connector (5A) and test harness E connector (2E) terminals.

**Connector & terminal**

**(5A) No. 9 — (2E) No. 3:**

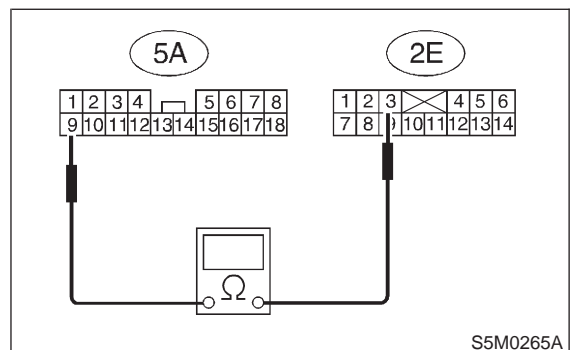

- CHECK** : Is resistance less than 10 Ω?
- YES** : Go to step 5P3.
- NO** : Replace airbag main harness. <Ref. to 5-5 [W4A0].>



### 5P3 : AIRBAG MAIN HARNESS INSPECTION

Measure resistance between each terminal of connectors (5A) and chassis ground.

**Connector & terminal**

**(5A) No. 9 (+) — Chassis ground (-):**

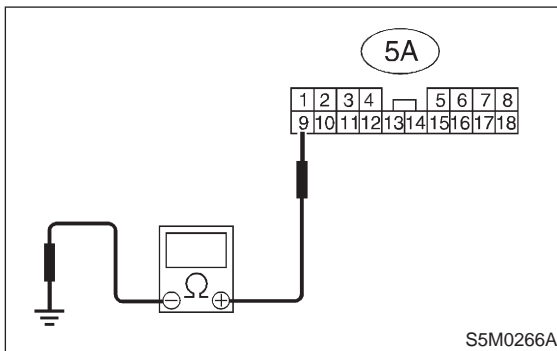

- CHECK** : **Is resistance more than 10 kΩ?**
- YES** : Go to step **5P4**.
- NO** : Replace airbag main harness. <Ref. to 5-5 [W4A0].>

### 5P4 : AIRBAG MAIN HARNESS INSPECTION

Measure resistance between each terminal of connectors (2E) and chassis ground.

**Connector & terminal**

**(2E) No. 3 (+) — Chassis ground (-):**

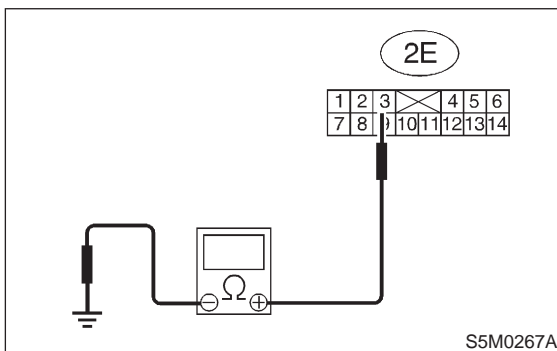

- CHECK** : **Is resistance more than 10 kΩ?**
- YES** : Go to step **5P5**.
- NO** : Replace airbag main harness. <Ref. to 5-5 [W4A0].>

### 5P5 : FUSE NO. 16 (IN JOINT BOX) INSPECTION

Make sure ignition switch is turned "OFF", then remove and visually check fuse No. 16 (in joint box).

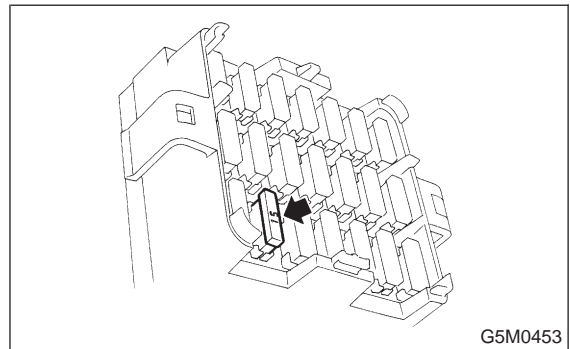

- CHECK** : **Is fuse No. 16 blown?**
- YES** : Replace fuse No. 16. If fuse No. 16 blows again, repair body harness.
- NO** : Repair body harness.

**Q: TROUBLE CODE 33**

**DIAGNOSIS:**

Front airbag module is inflated.

**CAUTION:**

Before performing diagnostics on airbag system, turn ignition switch "OFF", disconnect battery ground terminal, and then wait at least 20 seconds. <Ref. to 5-5 [W5A0].>

**5Q1 : CHECK IF TROUBLE CODE 33 IS INDICATED.**

Confirm flashing trouble code according to "BASIC DIAGNOSTICS PROCEDURE". <Ref. to 5-5 [T4A0].>

- CHECK** : *Is airbag warning light trouble code 33 indicated?*
- YES** : Replace airbag control module. <Ref. to 5-5 [W5A0].>
- NO** : Perform clear memory. <Ref. to 5-5 [T4C0].>

**R: TROUBLE CODE 34**

**DIAGNOSIS:**

- Passenger's airbag main harness circuit is shorted to power supply.
- Passenger's airbag module harness is shorted to power supply.
- Airbag control module is faulty.

**CAUTION:**

Before performing diagnostics on airbag system, turn ignition switch "OFF", disconnect battery ground terminal and then wait at least 20 seconds.

After 20 seconds elapse, remove instrument panel lower cover, and disconnect (AB3) and (AB8), (AB9) and (AB10).

**5R1 : AIRBAG MAIN HARNESS INSPECTION**

- 1) Disconnect connector (AB6) from airbag control module <Ref. to 5-5 [W5A0].>, and connect it to test harness E connector (1E).
- 2) Connect battery ground cable and turn ignition switch "ON" (engine off).
- 3) Measure voltage across each test harness E connector (2E) terminal and chassis ground.

**Connector & terminal**

**(2E) No. 2 (+) — Chassis ground (-):**

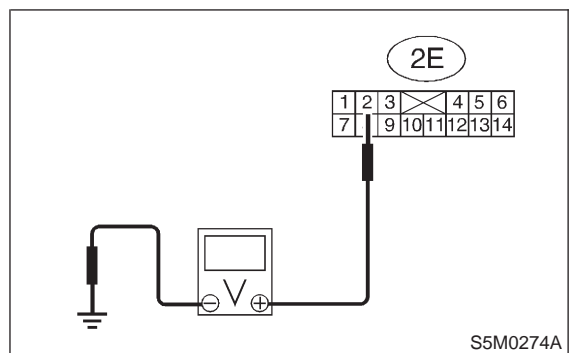

- CHECK** : *Is voltage less than 1 V?*
- YES** : Go to step 5R2.
- NO** : Replace airbag main harness. <Ref. to 5-5 [W4A0].>

**5R2 : AIRBAG MAIN HARNESS INSPECTION**

Measure voltage across each test harness E connector (2E) terminal and chassis ground.

**Connector & terminal**

**(2E) No. 5 (+) — Chassis ground (-):**

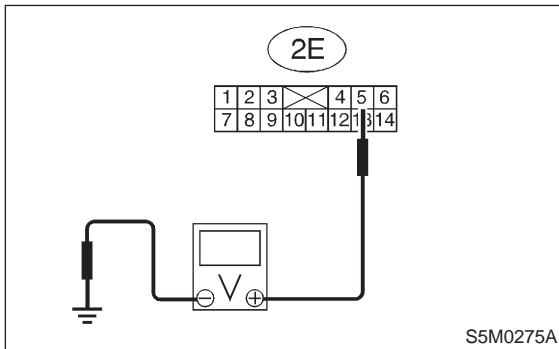

- CHECK** : **Is voltage less than 1 V?**
- YES** : Replace airbag control module. <Ref. to 5-5 [W5A0].>
- NO** : Replace airbag main harness. <Ref. to 5-5 [W4A0].>

**S: TROUBLE CODE 41**

**DIAGNOSIS:**

- Driver's airbag main harness circuit is shorted to ground.
- Driver's airbag module harness circuit is shorted to ground.
- Roll connector circuit is shorted to ground.
- Airbag control module is faulty.

**CAUTION:**

**Before performing diagnostics on airbag system, turn ignition switch "OFF", disconnect battery ground cable and then wait at least 20 seconds.**

**After 20 seconds elapse, remove instrument panel lower cover, and disconnect (AB3) and (AB8), (AB9) and (AB10).**

**5S1 : AIRBAG MAIN HARNESS INSPECTION**

- 1) Disconnect connector (AB6) from airbag control module <Ref. to 5-5 [W5A0].>, and connect it to test harness E connector (1E).
- 2) Measure resistance between test harness E connector (2E) terminals and chassis ground.

**Connector & terminal**

**(2E) No. 4 (+) — Chassis ground (-):**

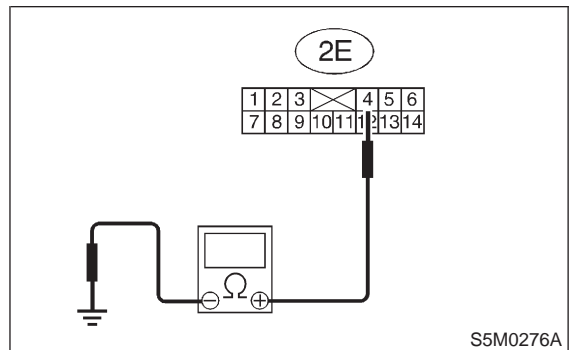

- CHECK** : **Is resistance more than 200 Ω?**
- YES** : Go to step **5S2**.
- NO** : Replace airbag main harness. <Ref. to 5-5 [W4A0].>

## 5-5 [T5S2]

# SUPPLEMENTAL RESTRAINT SYSTEM

## 5. Diagnostics Chart with Trouble Code

### 5S2 : AIRBAG MAIN HARNESS INSPECTION

Measure resistance between test harness E connector (2E) terminals and chassis ground.

#### Connector & terminal

(2E) No. 1 (+) — Chassis ground (-):

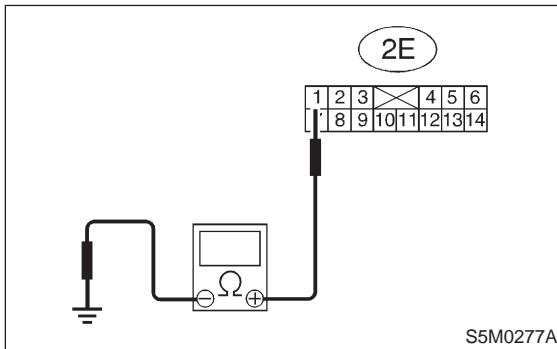

- CHECK** : Is resistance more than 200 Ω?
- YES** : Replace airbag control module. <Ref. to 5-5 [W5A0].>
- NO** : Replace airbag main harness. <Ref. to 5-5 [W4A0].>

### T: TROUBLE CODE 42

#### DIAGNOSIS:

- Passenger's airbag main harness circuit is shorted to ground.
- Passenger's airbag module harness circuit is shorted to ground.
- Airbag control module is faulty.

#### CAUTION:

Before performing diagnostics on airbag system, turn ignition switch "OFF", disconnect battery ground cable and then wait at least 20 seconds.

After 20 seconds elapse, remove instrument panel lower cover, and disconnect (AB3) and (AB8), (AB9) and (AB10).

### 5T1 : AIRBAG MAIN HARNESS INSPECTION

- 1) Disconnect connector (AB6) from airbag control module <Ref. to 5-5 [W5A0].>, and connect it to test harness E connector (1E).
- 2) Measure resistance between test harness E connector (2E) terminals and chassis ground.

#### Connector & terminal

(2E) No. 2 (+) — Chassis ground (-):

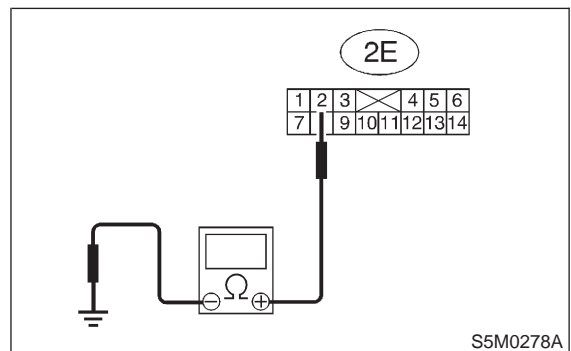

- CHECK** : Is resistance more than 200 Ω?
- YES** : Go to step 5T2.
- NO** : Replace airbag main harness. <Ref. to 5-5 [W4A0].>

**5T2 : AIRBAG MAIN HARNESS INSPECTION**

Measure resistance between test harness E connector (2E) terminals and chassis ground.

**Connector & terminal**

**(2E) No. 5 (+) — Chassis ground (-):**

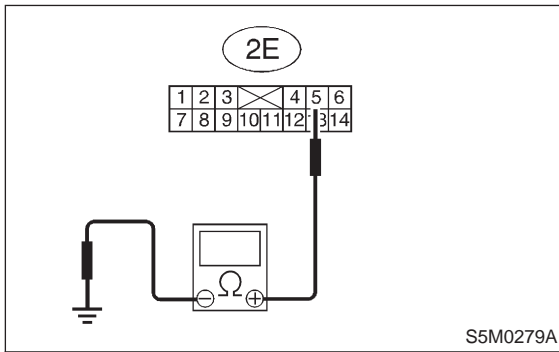

- CHECK** : Is resistance more than 200 Ω?
- YES** : Replace airbag control module. <Ref. to 5-5 [W5A0].>
- NO** : Replace airbag main harness. <Ref. to 5-5 [W4A0].>

**U: TROUBLE CODE 43**

**DIAGNOSIS:**

- Driver's airbag main harness circuit is shorted to power supply.
- Driver's airbag module harness is shorted to power supply.
- Roll connector is shorted to power supply.
- Airbag control module is faulty.

**CAUTION:**

**Before performing diagnostics on airbag system, turn ignition switch "OFF", disconnect battery ground terminal and then wait at least 20 seconds.**

**After 20 seconds elapse, remove instrument panel lower cover, and disconnect (AB3) and (AB8), (AB9) and (AB10).**

**5U1 : AIRBAG MAIN HARNESS INSPECTION**

- 1) Disconnect connector (AB6) from airbag control module <Ref. to 5-5 [W5A0].>, and connect it to test harness E connector (1E).
- 2) Connect battery ground cable and turn ignition switch "ON" (engine off).
- 3) Measure voltage across each test harness E connector (2E) terminal and chassis ground.

**Connector & terminal**

**(2E) No. 4 (+) — Chassis ground (-):**

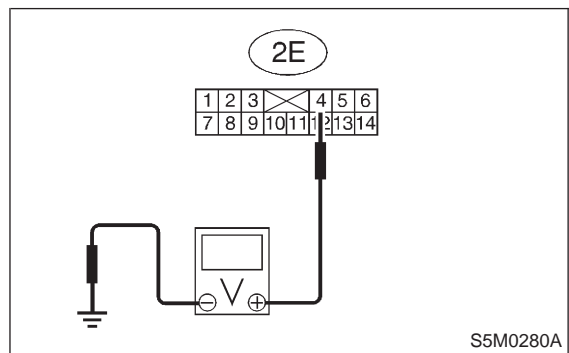

- CHECK** : Is voltage less than 1 V?
- YES** : Go to step 5U2.
- NO** : Replace airbag main harness. <Ref. to 5-5 [W4A0].>

**5U2 : AIRBAG MAIN HARNESS INSPECTION**

Measure voltage across each test harness E connector (2E) terminal and chassis ground.

**Connector & terminal**

**(2E) No. 1 (+) — Chassis ground (-):**

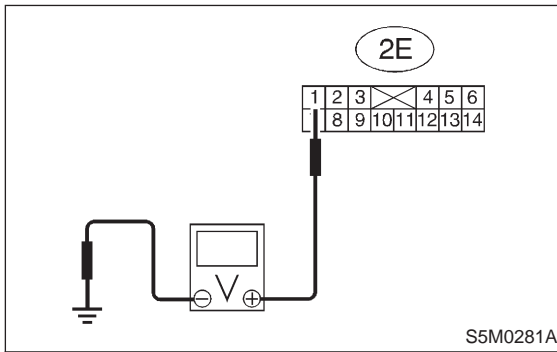

- CHECK** : **Is voltage less than 1 V?**
- YES** : Replace airbag control module. <Ref. to 5-5 [W5A0].>
- NO** : Replace airbag main harness. <Ref. to 5-5 [W4A0].>

**V: TROUBLE CODE 44**

**DIAGNOSIS:**

Side airbag module is inflated.

**CAUTION:**

**Before performing diagnostics on airbag system, turn ignition switch OFF, disconnect battery ground cable and then wait at least 20 seconds.**

**5V1 : CHECK IF TROUBLE CODE 44 IS INDICATED.**

Confirm flashing trouble code according to "BASIC DIAGNOSTICS PROCEDURE". <Ref. to 5-5 [T4A0].>

- CHECK** : **Is airbag warning light trouble code 44 indicated?**
- YES** : Replace front seat with side airbag module (Operating side). <Ref. to 5-3 [W100].>
- NO** : Perform clear memory. <Ref. to 5-5 [T4C0].>

## W: TROUBLE CODE 51

### DIAGNOSIS:

- Airbag main harness is faulty.
- Side airbag module (RH) is faulty.
- Airbag control module is faulty.

### CAUTION:

**Before performing diagnostics on airbag system, turn ignition switch OFF, disconnect battery ground cable and then wait at least 20 seconds.**

**After 20 seconds elapse, remove instrument panel lower cover, and disconnect (AB3) and (AB8), (AB9) and (AB10).**

### 5W1 : SIDE AIRBAG MODULE INSPECTION

- 1) Disconnect connector (AB26) and (AB27), and then connect connector (AB26) and test harness F connector (1F).
- 2) Connect test harness F connector (2F) and airbag resistor <Ref. to 5-5 [T3E0].>
- 3) Connect battery ground cable and then turn ignition switch ON.

- CHECK** : *Does the airbag warning light come on?*
- YES** : Replace front seat with side airbag module (RH). <Ref. to 5-3 [W100].>
- NO** : Go to step **5W2**.

### 5W2 : AIRBAG MAIN HARNESS INSPECTION

- 1) Turn ignition switch OFF, disconnect battery ground cable and then wait at least 20 seconds.
- 2) Disconnect test harness F and airbag resistor.
- 3) Disconnect connector (AB18) from airbag control module and connect it to test harness E connector (1E).
- 4) Measure resistance of test harness E connector (3E) terminal.

#### Connector & terminal

**(3E) No. 7 — (3E) No. 9:**

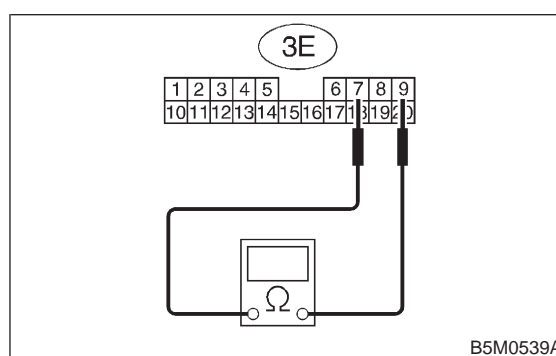

- CHECK** : *Is the resistance more than 1 MΩ?*
- YES** : Go to step **5W3**.
- NO** : Replace airbag main harness. <Ref. to 5-5 [W4A0].>

### 5W3 : AIRBAG MAIN HARNESS INSPECTION

Measure resistance of test harness E connector (3F) terminal.

#### Connector & terminal

**(3F) No. 3 — (3F) No. 4:**

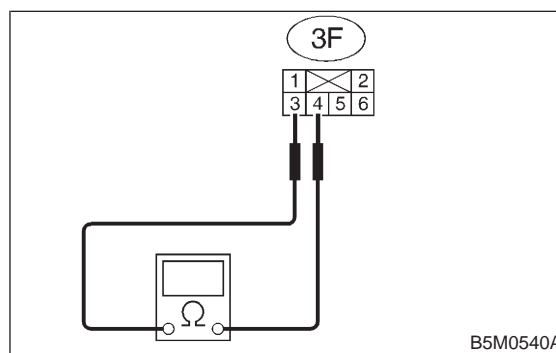

- CHECK** : *Is the resistance more than 1 MΩ?*
- YES** : Go to step **5W4**.
- NO** : Replace airbag main harness. <Ref. to 5-5 [W4A0].>

## 5-5 [T5W4]

# SUPPLEMENTAL RESTRAINT SYSTEM

### 5. Diagnostics Chart with Trouble Code

#### 5W4 : AIRBAG MAIN HARNESS INSPECTION

Measure resistance between connector (3F) terminal and chassis ground.

##### Connector & terminal

(3F) No. 3 (+) — Chassis ground (-):

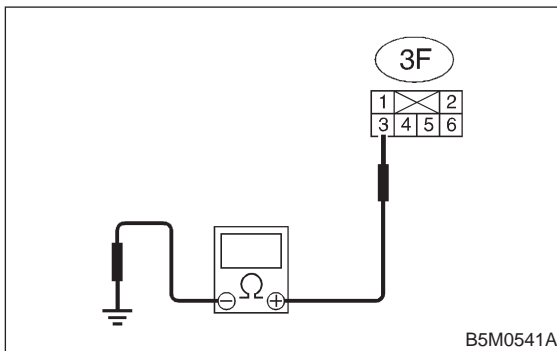

- CHECK** : Is the resistance more than 1 MΩ?
- YES** : Go to step 5W5.
- NO** : Replace airbag main harness. <Ref. to 5-5 [W4A0].>

#### 5W5 : AIRBAG MAIN HARNESS INSPECTION

Measure resistance between connector (3F) terminal and chassis ground.

##### Connector & terminal

(3F) No. 4 (+) — Chassis ground (-):

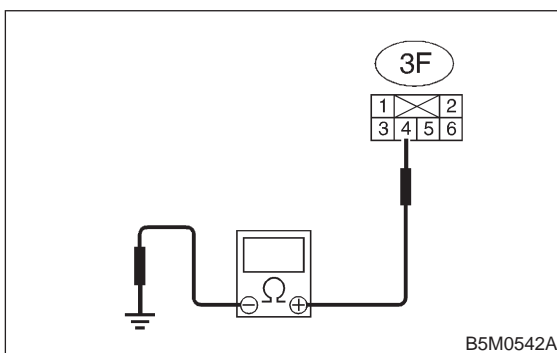

- CHECK** : Is the resistance more than 1 MΩ?
- YES** : Go to step 5W6.
- NO** : Replace airbag main harness. <Ref. to 5-5 [W4A0].>

#### 5W6 : AIRBAG MAIN HARNESS INSPECTION

Measure resistance between connector (3E) terminal and chassis ground.

##### Connector & terminal

(3E) No. 7 (+) — Chassis ground (-):

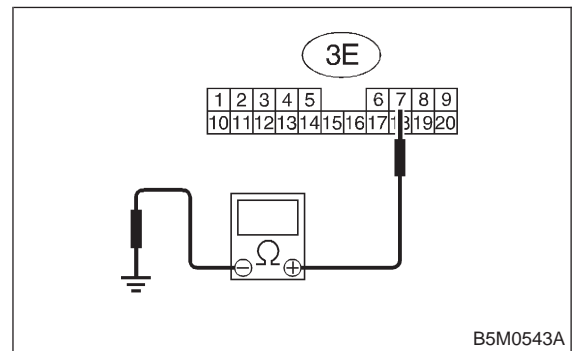

- CHECK** : Is the resistance more than 1 MΩ?
- YES** : Go to step 5W7.
- NO** : Replace airbag main harness. <Ref. to 5-5 [W4A0].>

#### 5W7 : AIRBAG MAIN HARNESS INSPECTION

Measure resistance between connector (3E) terminal and chassis ground.

##### Connector & terminal

(3E) No. 9 (+) — Chassis ground (-):

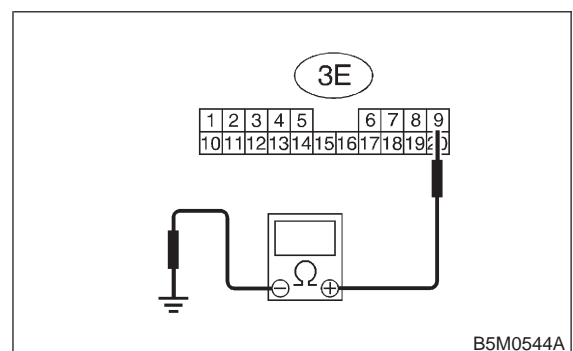

- CHECK** : Is the resistance more than 1 MΩ?
- YES** : Replace airbag control module. <Ref. to 5-5 [W5A0].>
- NO** : Replace airbag main harness. <Ref. to 5-5 [W4A0].>



**X: TROUBLE CODE 52**

**DIAGNOSIS:**

- Airbag main harness is faulty.
- Side airbag module (LH) is faulty.
- Airbag control module is faulty.

**CAUTION:**

**Before performing diagnostics on airbag system, turn ignition switch OFF, disconnect battery ground cable and then wait at least 20 seconds.**

**After 20 seconds elapse, remove instrument panel lower cover, and disconnect (AB3) and (AB8), (AB9) and (AB10).**

**5X1 : SIDE AIRBAG MODULE INSPECTION**

- 1) Disconnect connector (AB21) and (AB22), and then connect connector (AB21) and test harness F connector (1F).
- 2) Connect test harness F connector (2F) and airbag resistor. <Ref. to 5-5 [T3F0].>
- 3) Connect battery ground cable and then turn ignition switch ON.

- CHECK** : Does the airbag warning light come on?
- YES** : Replace front seat with side airbag module (LH). <Ref. to 5-3 [W100].>
- NO** : Go to step **5X2**.

**5X2 : AIRBAG MAIN HARNESS INSPECTION**

- 1) Turn ignition switch OFF, disconnect battery ground cable and then wait at least 20 seconds.
- 2) Disconnect test harness F and airbag resistor.
- 3) Disconnect connector (AB17) from airbag control module and connect it to test harness E connector (1E).
- 4) Measure resistance of test harness E connector (3E) terminal.

**Connector & terminal**  
**(3E) No. 10 — (3E) No. 12:**

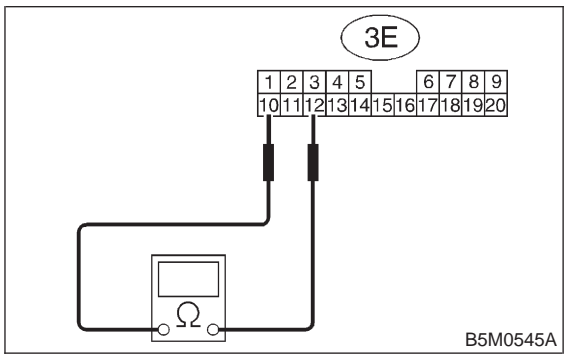

- CHECK** : Is the resistance more than 1 MΩ?
- YES** : Go to step **5X3**.
- NO** : Replace airbag main harness. <Ref. to 5-5 [W4A0].>

**5X3 : AIRBAG MAIN HARNESS INSPECTION**

Measure resistance of test harness E connector (3F) terminal.

**Connector & terminal**  
**(3F) No. 3 — (3F) No. 4:**

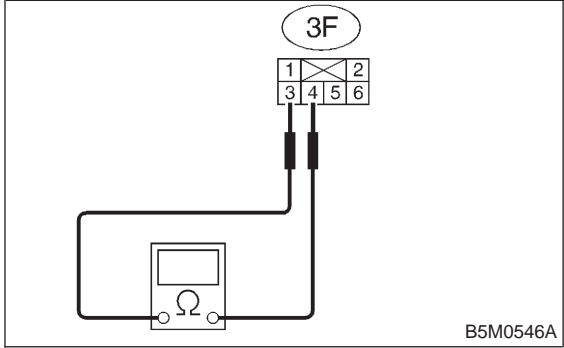

- CHECK** : Is the resistance more than 1 MΩ?
- YES** : Go to step **5X4**.
- NO** : Replace airbag main harness. <Ref. to 5-5 [W4A0].>

## 5-5 [T5X4]

## SUPPLEMENTAL RESTRAINT SYSTEM

### 5. Diagnostics Chart with Trouble Code

#### 5X4 : AIRBAG MAIN HARNESS INSPECTION

Measure resistance between connector (3F) terminal and chassis ground.

##### Connector & terminal

(3F) No. 3 (+) — Chassis ground (-):

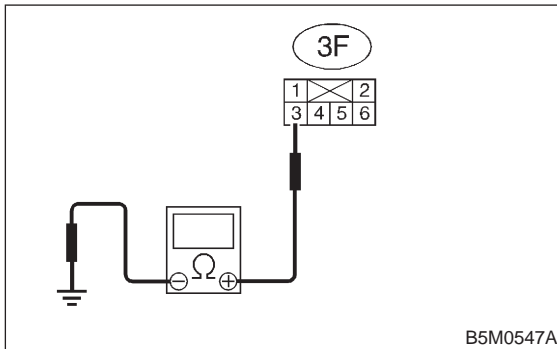

- CHECK** : Is the resistance more than 1 MΩ?
- YES** : Go to step 5X5.
- NO** : Replace airbag main harness. <Ref. to 5-5 [W4A0].>

#### 5X5 : AIRBAG MAIN HARNESS INSPECTION

Measure resistance between connector (3F) terminal and chassis ground.

##### Connector & terminal

(3F) No. 4 (+) — Chassis ground (-):

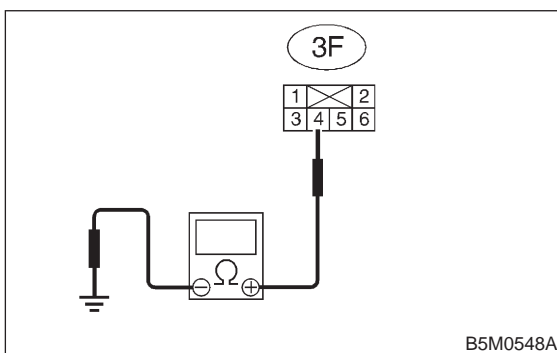

- CHECK** : Is the resistance more than 1 MΩ?
- YES** : Go to step 5X6.
- NO** : Replace airbag main harness. <Ref. to 5-5 [W4A0].>

#### 5X6 : AIRBAG MAIN HARNESS INSPECTION

Measure resistance between connector (3E) terminal and chassis ground.

##### Connector & terminal

(3E) No. 10 (+) — Chassis ground (-):

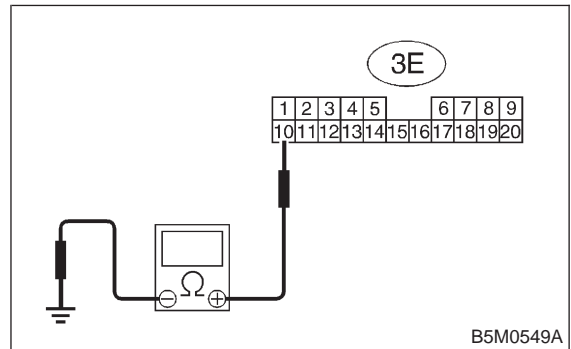

- CHECK** : Is the resistance more than 1 MΩ?
- YES** : Go to step 5X7.
- NO** : Replace airbag main harness. <Ref. to 5-5 [W4A0].>

#### 5X7 : AIRBAG MAIN HARNESS INSPECTION

Measure resistance between connector (3E) terminal and chassis ground.

##### Connector & terminal

(3E) No. 12 (+) — Chassis ground (-):

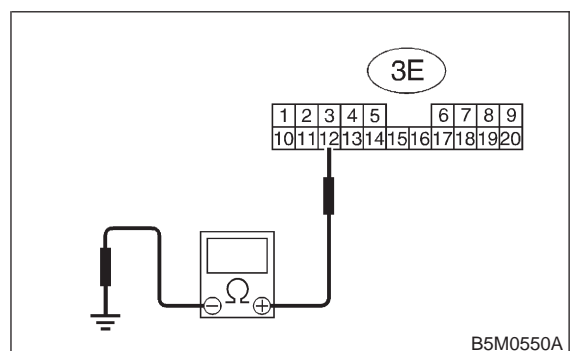

- CHECK** : Is the resistance more than 1 MΩ?
- YES** : Replace airbag control module. <Ref. to 5-5 [W5A0].>
- NO** : Replace airbag main harness. <Ref. to 5-5 [W4A0].>

**Y: AIRBAG WARNING LIGHT REMAINS ON.**

**DIAGNOSIS:**

- Airbag warning light is faulty.
- Airbag control module to airbag warning light harness circuit is shorted or open.
- Grounding circuit is faulty.
- Airbag control module is faulty.
- (AB1) and (B31) are not connected properly.
- (AB6) is not connected properly to airbag control module.

**CAUTION:**

**Before performing diagnostics on airbag system, turn ignition switch "OFF", disconnect battery ground cable and then wait at least 20 seconds.**

**5Y1 : CHECK POOR CONTACT IN CONNECTORS (AB1) AND (B31).**

- 1) Remove front pillar lower trim (Driver side).
- 2) Check poor contact in connectors (AB1) and (B31).

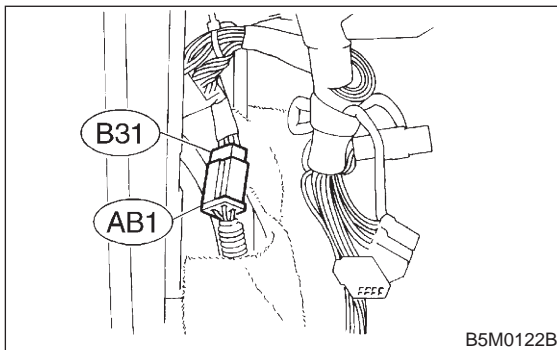

- CHECK** : *Is there poor contact in double lock of connectors (AB1) and (B31)?*
- YES** : Repair poor contact in double lock of connectors (AB1) and (B31).
- NO** : Go to step **5Y2**.

**5Y2 : INSPECTION OF AIRBAG WARNING LIGHT**

- 1) Turn ignition switch "OFF" and connect body harness connector (B31) to test connector A connector (1A).

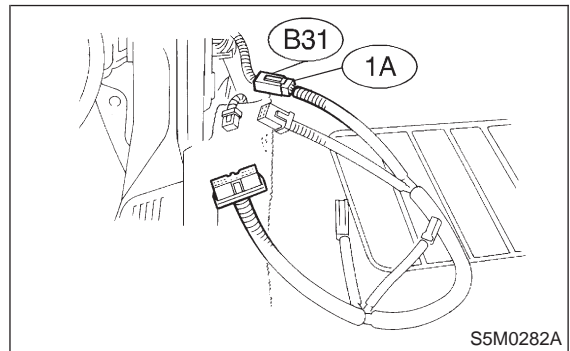

- 2) Connect battery ground cable and turn ignition switch "ON", (engine off) and connect connectors (3A) and (4A).

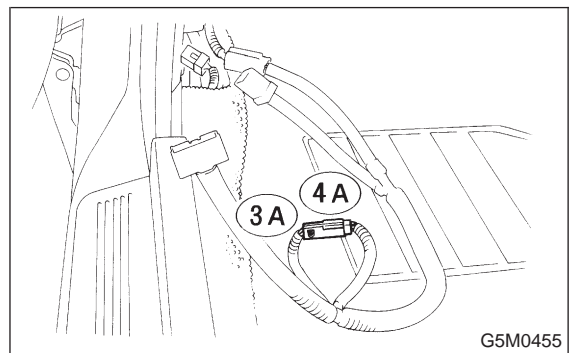

- CHECK** : *Does the airbag warning light come off?*
- YES** : Go to step **5Y4**.
- NO** : Go to step **5Y3**.

## 5-5 [T5Y3]

# SUPPLEMENTAL RESTRAINT SYSTEM

## 5. Diagnostics Chart with Trouble Code

### 5Y3 : INSPECTION OF BODY HARNESS

Check body harness.

#### NOTE:

After problem has been eliminated, disconnect connectors (3A) and (4A).

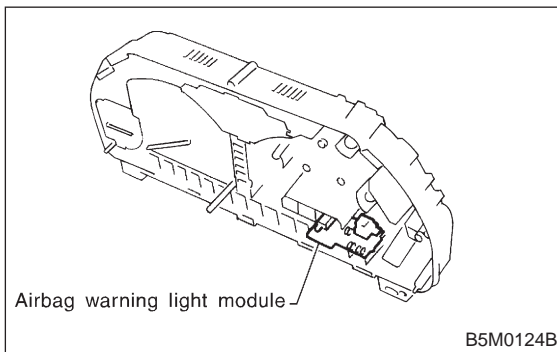

- CHECK** : *Is there anything unusual to body harness?*
- YES** : Repair body harness.
- NO** : Replace airbag warning light module.

### 5Y4 : CHECK POOR CONTACT IN CONNECTOR (AB6).

Check connector (AB6) connected to airbag control module. <Ref. to 5-5 [W5A0].>

- CHECK** : *Is there poor contact in connector (AB6)?*
- YES** : Repair poor contact in connector (AB6).
- NO** : Go to step **5Y5**.

### 5Y5 : INSPECTION OF AIRBAG MAIN HARNESS

- 1) Turn ignition switch "OFF", disconnect battery ground cable and then wait at least 20 seconds, and re-connect connectors (AB1) and (B31).
- 2) Remove instrument panel lower cover and disconnect (AB3) with (AB8), then disconnect connector (AB6) from airbag control module, <Ref. to 5-5 [W5A0].> and connect it to test harness E connector (1E).
- 3) Connect battery ground cable and turn ignition switch "ON", (engine off) and connect connectors (4E) and (5E).

#### NOTE:

After problem has been eliminated, disconnect connectors (4E) and (5E).

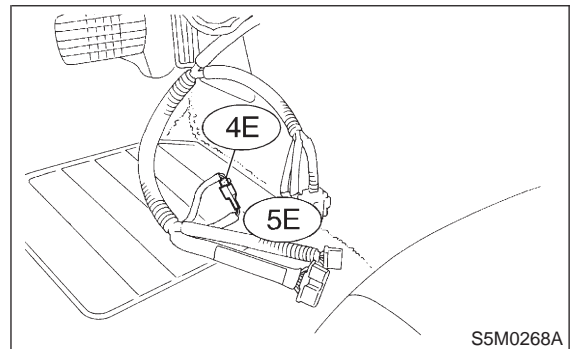

- CHECK** : *Does the airbag warning light come on?*
- YES** : Go to step **5Y6**.
- NO** : Replace airbag main harness. <Ref. to 5-5 [W4A0].>

**5Y6 : GROUNDING CIRCUIT INSPECTION**

- 1) Turn ignition switch "OFF", disconnect battery ground cable and then wait at least 20 seconds.
- 2) Disconnect connector (AB1) from body harness connector (B31), and connect connector (B31) to test harness A connector (1A).
- 3) Measure resistance between connector (5A) terminal and chassis ground.

**Connector & terminal**

**(5A) No. 17 (+) — Chassis ground (-):**

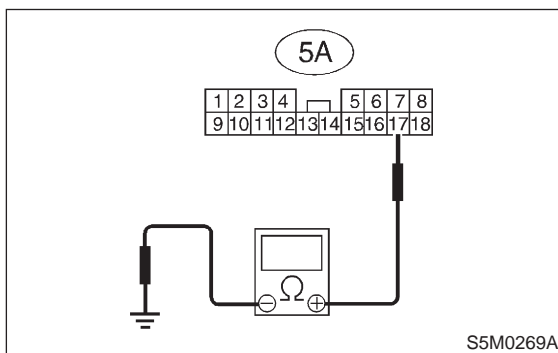

- CHECK** : Is resistance less than 10 Ω?
- YES** : Go to step 5Y7.
- NO** : Repair body grounding circuit.

**5Y7 : GROUNDING CIRCUIT INSPECTION**

Measure resistance between connector (5A) terminal and chassis ground.

**Connector & terminal**

**(5A) No. 18 (+) — Chassis ground (-):**

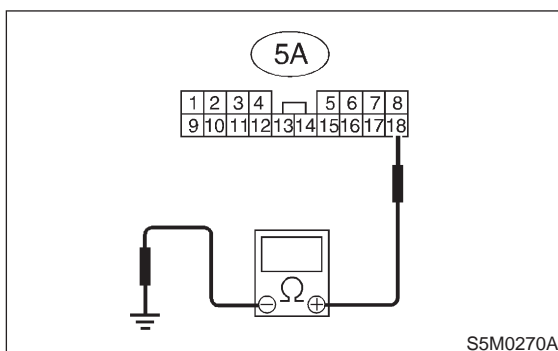

- CHECK** : Is resistance less than 10 Ω?
- YES** : Go to step 5Y8.
- NO** : Repair body grounding circuit.

**5Y8 : INSPECTION OF AIRBAG MAIN HARNESS**

- 1) Connect connectors (AB1) and (B31). Disconnect connector (AB6) from airbag control module <Ref. to 5-5 [W5A0].>, and connect it to test harness E connector (1E).
- 2) Measure resistance between each test harness E connector (2E) terminal and chassis ground.

**Connector & terminal**

**(2E) No. 9 (+) — Chassis ground (-):**

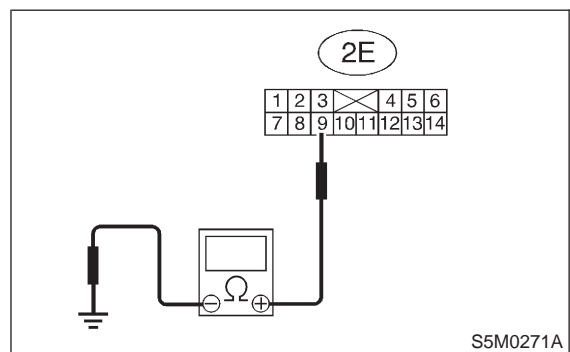

- CHECK** : Is resistance less than 10 Ω?
- YES** : Go to step 5Y9.
- NO** : Replace airbag main harness. <Ref. to 5-5 [W4A0].>

**5Y9 : INSPECTION OF AIRBAG MAIN HARNESS**

Measure resistance between each test harness E connector (2E) terminal and chassis ground.

**Connector & terminal**

**(2E) No. 10 (+) — Chassis ground (-):**

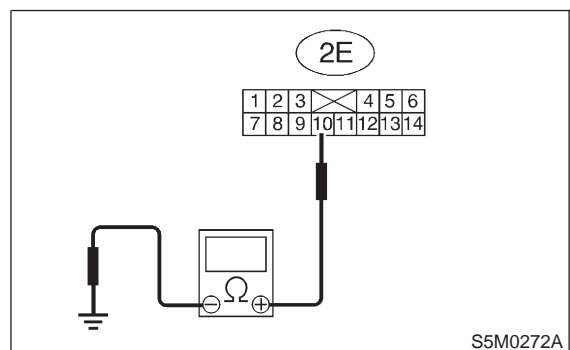

- CHECK** : Is resistance less than 10 Ω?
- YES** : Replace airbag control module. <Ref. to 5-5 [W5A0].>
- NO** : Replace airbag main harness. <Ref. to 5-5 [W4A0].>

**Z: AIRBAG WARNING LIGHT REMAINS OFF.**

**DIAGNOSIS:**

- Fuse No. 15 is blown. (In joint box)
- Body harness circuit is open.
- Airbag warning light is faulty.
- Airbag main harness is faulty.
- Airbag control module is faulty.

**CAUTION:**

Before performing diagnostics on airbag system, turn ignition switch "OFF", disconnect battery ground terminal, and then wait at least 20 seconds.

**5Z1 : FUSE NO. 15 (IN JOINT BOX) INSPECTION**

Remove and visually check fuse No. 15 (In joint box).

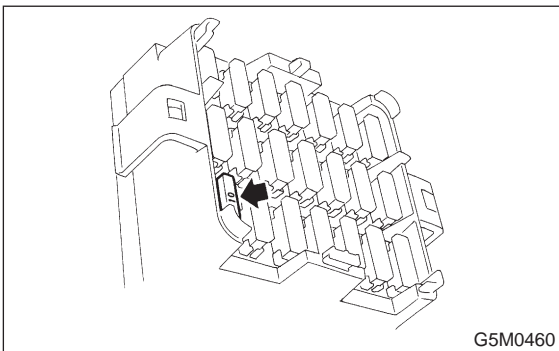

- CHECK** : *Is fuse No. 15 blown?*
- YES** : Replace fuse No. 15. If fuse No. 15 blows again, Go to step 5Z2.
- NO** : Go to step 5Z2.

**5Z2 : BODY HARNESS INSPECTION**

Turn ignition switch "ON" (engine off) to make sure other warning lights (in combination meter) illuminate.

- CHECK** : *Do all the warning lights (in combination meter) except airbag warning light come on?*
- YES** : Go to step 5Z3.
- NO** : Repair body harness.

**5Z3 : AIRBAG WARNING LIGHT MODULE (IN COMBINATION METER) INSPECTION**

- 1) Turn ignition switch "OFF", disconnect battery ground cable and then wait at least 20 seconds.
- 2) Disconnect body harness connector (B31) from connector (AB1).

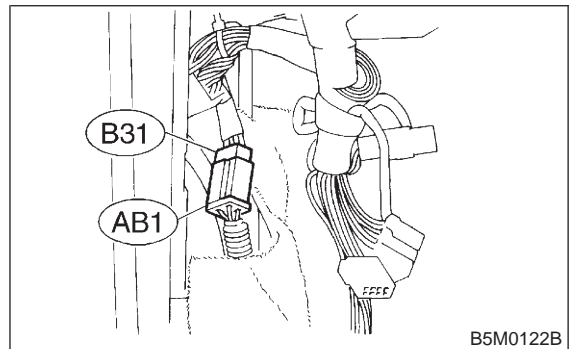

- 3) Connect battery ground cable and turn ignition switch "ON" (engine off) to make sure airbag warning light illuminates.

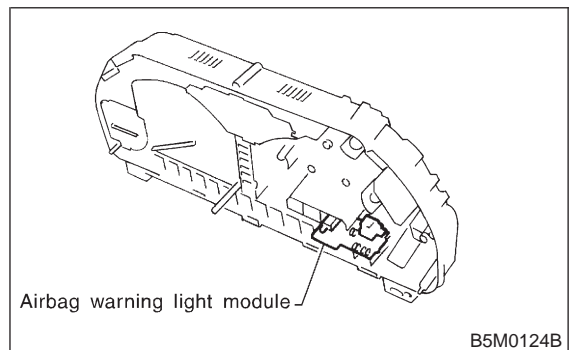

- CHECK** : *Does the airbag warning light come on?*
- YES** : Go to step 5Z4.
- NO** : Replace airbag warning light module.

**5Z4 : AIRBAG MAIN HARNESS INSPECTION**

- 1) Turn ignition switch "OFF", disconnect battery ground cable and then wait at least 20 seconds.
- 2) Connect body harness connector (B31) and connector (AB1).
- 3) Disconnect connectors (AB3) and (AB8) below steering column. <Ref. to 5-5 [M2F2].>

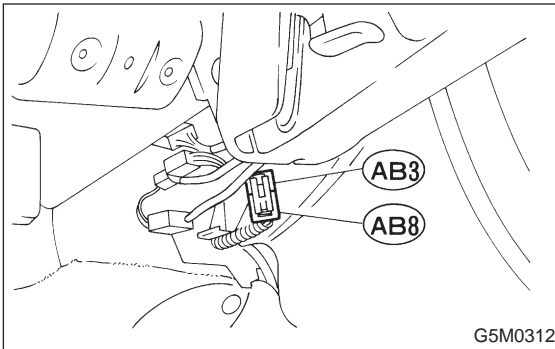

- 4) Disconnect connector (AB6) from airbag control module. <Ref. to 5-5 [W5A0].>
- 5) Connect battery ground cable and turn ignition switch "ON" to make sure airbag warning light illuminates.

- CHECK** : **Does the airbag warning light come on?**
- YES** : Replace airbag control module. <Ref. to 5-5 [W5A0].>
- NO** : Replace airbag main harness. <Ref. to 5-5 [W4A0].>

**AA: WARNING LIGHT INDICATES TROUBLE CODE, THEN NORMAL CODE. (FLASHING TROUBLE CODE.)**

**DIAGNOSIS:**

Airbag system component parts are faulty.

**CAUTION:**

**Before performing diagnostics on airbag system, turn ignition switch "OFF", disconnect battery ground cable, and then wait at least 20 seconds.**

**5AA1 : AIRBAG COMPONENT PARTS APPEARANCE INSPECTION**

- 1) Conduct on-board diagnostic and call up trouble codes stored in memory. <Ref. to 5-5 [T4B0].>
- 2) Select trouble code required to check airbag component parts from those listed in table and reproduce symptom.



## 5-5 [T5AA1]

## SUPPLEMENTAL RESTRAINT SYSTEM

### 5. Diagnostics Chart with Trouble Code

Trouble codes	Check parts	Index. No.
03	<ul style="list-style-type: none"> <li>● Airbag main harness</li> <li>● Front sub sensor and front sub sensor harness (Both sides)</li> </ul>	<Ref. to 5-5 [W400].> <Ref. to 5-5 [W700].>
04	<ul style="list-style-type: none"> <li>● Airbag module (Passenger)</li> <li>● Airbag main harness</li> <li>● Airbag control module</li> </ul>	<Ref. to 5-5 [W3A2].> <Ref. to 5-5 [W400].> <Ref. to 5-5 [W500].>
08	<ul style="list-style-type: none"> <li>● Airbag control module</li> <li>● Side airbag module RH in front seat</li> </ul>	<Ref. to 5-5 [W500].> <Ref. to 5-3 [W100].>
09	<ul style="list-style-type: none"> <li>● Airbag control module</li> <li>● Side airbag module LH in front seat</li> </ul>	<Ref. to 5-5 [W500].> <Ref. to 5-3 [W100].>
11	<ul style="list-style-type: none"> <li>● Fuse No. 8</li> <li>● Airbag main harness</li> <li>● Airbag control module</li> <li>● Body harness</li> </ul>	<Ref. to 5-5 [T5F5].> <Ref. to 5-5 [W400].> <Ref. to 5-5 [W500].> <Ref. to 5-3 [W100].>
12	<ul style="list-style-type: none"> <li>● Roll connector</li> <li>● Airbag module (Driver)</li> <li>● Airbag main harness</li> <li>● Airbag control module</li> </ul>	<Ref. to 5-5 [W600].> <Ref. to 5-5 [W3A1].> <Ref. to 5-5 [W400].> <Ref. to 5-5 [W500].>
13	<ul style="list-style-type: none"> <li>● Airbag module (Driver)</li> <li>● Roll connector</li> <li>● Airbag main harness</li> <li>● Airbag control module</li> </ul>	<Ref. to 5-5 [W3A1].> <Ref. to 5-5 [W600].> <Ref. to 5-5 [W400].> <Ref. to 5-5 [W500].>
15	Side airbag sensor RH	<Ref. to 5-5 [W800].>
16	Side airbag sensor RH	<Ref. to 5-5 [W800].>
21	Airbag control module	<Ref. to 5-5 [W500].>
22	<ul style="list-style-type: none"> <li>● Airbag module (Passenger)</li> <li>● Airbag main harness</li> <li>● Airbag control module</li> </ul>	<Ref. to 5-5 [W3A2].> <Ref. to 5-5 [W400].> <Ref. to 5-5 [W500].>
25	Side airbag module LH in front seat	<Ref. to 5-3 [W100].>
26	Side airbag module LH in front seat	<Ref. to 5-3 [W100].>
33	Airbag control module	<Ref. to 5-5 [W500].>
34	<ul style="list-style-type: none"> <li>● Airbag main harness</li> <li>● Airbag module (Passenger)</li> <li>● Airbag control module</li> </ul>	<Ref. to 5-5 [W400].> <Ref. to 5-5 [W3A2].> <Ref. to 5-5 [W500].>
41	<ul style="list-style-type: none"> <li>● Airbag module (Driver)</li> <li>● Roll connector</li> <li>● Airbag main harness</li> <li>● Airbag control module</li> </ul>	<Ref. to 5-5 [W3A1].> <Ref. to 5-5 [W600].> <Ref. to 5-5 [W400].> <Ref. to 5-5 [W500].>
42	<ul style="list-style-type: none"> <li>● Airbag module (Passenger)</li> <li>● Airbag main harness</li> <li>● Airbag control module</li> </ul>	<Ref. to 5-5 [W3A2].> <Ref. to 5-5 [W400].> <Ref. to 5-5 [W500].>
43	<ul style="list-style-type: none"> <li>● Airbag module (Driver)</li> <li>● Roll connector</li> <li>● Airbag main harness</li> <li>● Airbag control module</li> </ul>	<Ref. to 5-5 [W3A1].> <Ref. to 5-5 [W600].> <Ref. to 5-5 [W400].> <Ref. to 5-5 [W500].>
44	Side airbag module in front seat	<Ref. to 5-3 [W100].>
51	Side airbag module RH in front seat	<Ref. to 5-3 [W100].>
52	Side airbag module LH in front seat	<Ref. to 5-3 [W100].>

3) Conduct appearance inspection on parts selected.

#### NOTE:

Also check connector terminals, wiring harness, case, etc. for damage.

**CHECK** : *Is there anything unusual about the appearance of airbag component parts?*

**YES** : Replace faulty airbag component parts.

**NO** : Go to step **5AA2**.



**5AA2 : AIRBAG COMPONENT PARTS VIBRATION INSPECTION**

- 1) Gently shake check parts (to determine faults.).
- 2) To check airbag module or roll connector, turn and tilt steering wheel.

**CAUTION:**

**Do not shake or vibrate airbag control module.**

**CHECK** : *Does the component malfunction again when shaking?*

**YES** : Replace faulty airbag component parts.

**NO** : Go to step 5AA3.

**5AA3 : SHOWERING INSPECTION TO BODY**

Spray water on vehicle body.

**CAUTION:**

**Do not directly spray water on airbag components.**

**NOTE:**

Also check wiring harnesses as water may leak along them and get airbag component parts wet.

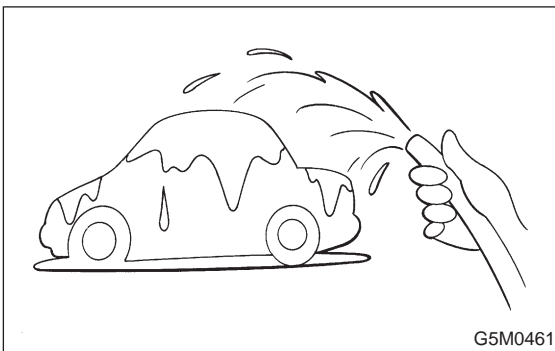

**CHECK** : *Does water leak into the passenger compartment when showering vehicle?*

**YES** : Replace faulty airbag component parts.

**NO** : Perform clear memory. <Ref. to 5-5 [T4C0].>

**AB: WARNING LIGHT INDICATES TROUBLE CODE, THEN NORMAL CODE. (FLASHING NORMAL CODE.)**

**DIAGNOSIS:**

- Airbag connector is faulty.
- Fuse No. 16 is blown. (In joint box)
- Airbag main harness is faulty.
- Airbag control module is faulty.
- Body harness is faulty.

**CAUTION:**

**Before performing diagnostics on airbag system, turn ignition switch "OFF", disconnect battery ground cable, and then wait at least 20 seconds.**

**5AB1 : AIRBAG CONNECTOR APPEARANCE INSPECTION**

Conduct appearance inspection on airbag connectors (AB2) through (AB28). <Ref. to 5-5 [T100].>

**NOTE:**

Check terminals, case and wiring harnesses for damage.

**CHECK** : *Is there anything unusual about the appearance of connectors (AB2) through (AB28)?*

**YES** : Replace faulty airbag component parts.

**NO** : Go to step 5AB2.

**5AB2 : AIRBAG CONNECTOR VIBRATION INSPECTION**

Conduct vibration inspection on airbag connectors (AB2) through (AB28). <Ref. to 5-5 [T100].>

**NOTE:**

Gently shake each airbag connector.

**CHECK** : *Do the connectors (AB2) through (AB28) malfunction again when shaking?*

**YES** : Replace faulty airbag component parts.

**NO** : Go to step 5AB3.

## 5-5 [T5AB3]

# SUPPLEMENTAL RESTRAINT SYSTEM

## 5. Diagnostics Chart with Trouble Code

### 5AB3 : SHOWERING INSPECTION TO BODY

Spray water on vehicle body.

#### CAUTION:

**Do not directly spray water on airbag components.**

#### NOTE:

If leaks are noted, also check wiring harnesses as water may leak along them and wet airbag connectors.



**CHECK** : *Does water leak into the passenger compartment when showering vehicle?*

**YES** : Replace faulty airbag component parts.

**NO** : Go to step **5AB4**.

### 5AB4 : FUSE NO. 16 (IN JOINT BOX), AIRBAG MAIN HARNESS, AIRBAG CONTROL MODULE, BODY HARNESS APPEARANCE INSPECTION

Conduct appearance inspection on fuse No. 16 <Ref. to 5-5 [T5P5].>, airbag main harness <Ref. to 5-5 [W4A0].>, airbag control module <Ref. to 5-5 [W5A0].> and body harness.

#### NOTE:

Also check connectors, terminals, wiring harness and case for damage.

**CHECK** : *Is there anything unusual about the appearance of fuse No. 16, airbag main harness, airbag control module or body harness?*

**YES** : Replace faulty airbag component parts.

**NO** : Go to step **5AB5**.

### 5AB5 : FUSE NO. 16 (IN JOINT BOX), AIRBAG MAIN HARNESS, BODY HARNESS VIBRATION INSPECTION

Conduct vibration inspection on fuse No. 16, airbag main harness and body harness.

#### CAUTION:

**Do not shake or vibrate airbag control module.**

#### NOTE:

Gently shake each part.

**CHECK** : *Do fuse No. 16, airbag main harness or body harness malfunction again when shaking?*

**YES** : Replace faulty airbag component parts.

**NO** : Go to step **5AB6**.

### 5AB6 : SHOWERING INSPECTION TO BODY

Spray water on vehicle body.

#### CAUTION:

**Do not directly spray water on each part.**

#### NOTE:

If leaks are noted, check wiring harnesses as water may leak along them and get parts wet.



**CHECK** : *Does water leak into the passenger compartment when showering vehicle?*

**YES** : Replace faulty airbag component parts.

**NO** : Go to step **5AB7**.

**5AB7 : WARNING LIGHT ILLUMINATION CHECK**

Turn ignition switch "ON" (engine off) and observe airbag warning light.

- CHECK** : ***Does the airbag warning light come on for about 7 seconds, then go out and stay out?***
- YES** : Perform clear memory. <Ref. to 5-5 [T4C0].>
- NO** : Go to "DIAGNOSTICS PROCEDURE". <Ref. to 5-5 [T4D0].>

**5-5 [T5AB7]**

**SUPPLEMENTAL RESTRAINT SYSTEM**

5. Diagnostics Chart with Trouble Code

---

**MEMO:**