

5. Oil Pan and Oil Strainer

- The oil pan is attached to the cylinder block using liquid gasket for sealing. The oil strainer is a metal net type and removes large foreign particles from the engine oil. It is located in the middle of the oil pan. The pipe from the strainer is connected to the suction port of the oil pump in the left bank of the cylinder block.
- There is a baffle plate in the oil pan, near the bottom of the cylinder block. It stabilizes the oil level and reinforces the oil pan.

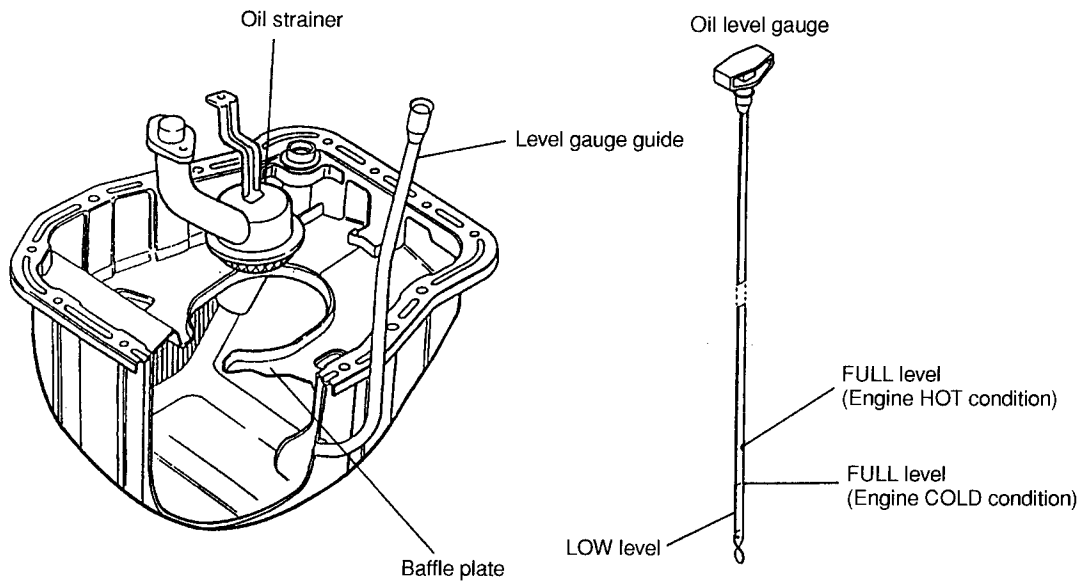

S2H0852A