

10. Piston

- The pistons are of a slipper skirt design for reduced weight and friction. The oil control ring groove utilizes a thermal design.
- The piston pin is offset either downward (Nos. 1 and 3 pistons) or upward (Nos. 2 and 4 pistons).
- The piston head has recesses to prevent interference with the intake and exhaust valves. It also has engraved marks to identify the piston size and the direction of installation. All the pistons are common in their design.
- Three piston rings are used for each piston – two compression rings and one oil control ring. The top piston ring has inner bevels and the second piston ring has a cut on the bottom outside to reduce oil consumption.

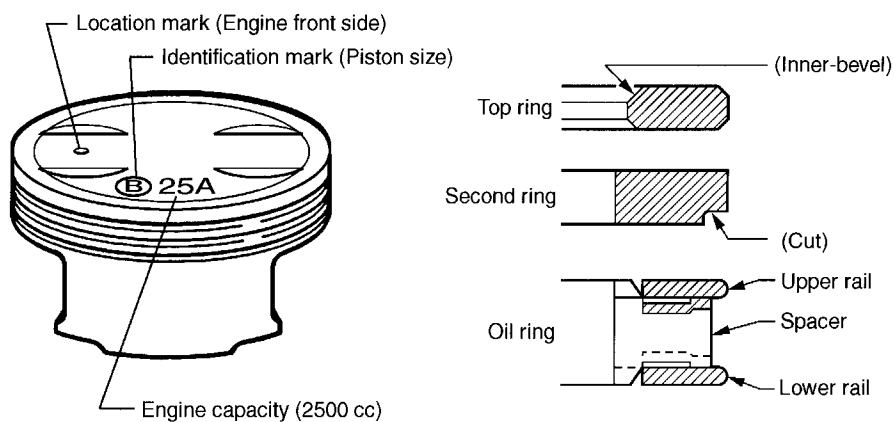

B2H3411C