

## 23. Planetary Gear and Low Clutch

S510212

### A: REMOVAL

S510212A18

- 1) Extract the torque converter clutch assembly. <Ref. to AT-35, REMOVAL, Torque Converter Clutch Assembly.>
- 2) Remove the input shaft.

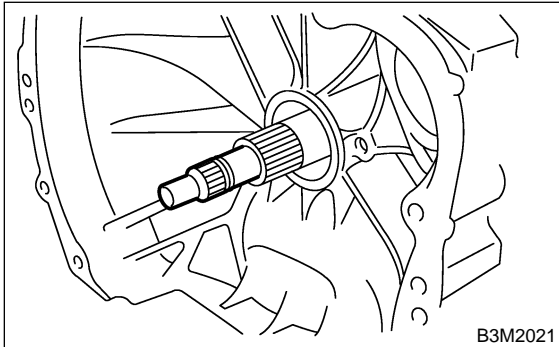

- 3) Disconnect the air breather hose. <Ref. to AT-28, REMOVAL, Air Breather Hose.>
- 4) Disconnect transmission harness connector from stay.

#### NOTE:

Lift-up lever behind the connector and disconnect from stay.

- 5) Disconnect inhibitor switch connector from stay.
- 6) Remove the oil charger pipe, and remove the O-ring from the flange face. Attach the O-ring to the pipe. <Ref. to AT-29, REMOVAL, Oil Charger Pipe.>
- 7) Remove the oil cooler inlet and outlet pipes. <Ref. to AT-30, REMOVAL, Oil Cooler Pipes.>
- 8) Remove rear vehicle speed sensor, and separate the transmission case and extension case. <Ref. to AT-36, REMOVAL, Extension Case.>
- 9) Remove reduction driven gear.  
WITHOUT VTD <Ref. to AT-48, WITHOUT VTD, REMOVAL, Reduction Driven Gear.>  
WITH VTD <Ref. to AT-48, WITH VTD, REMOVAL, Reduction Driven Gear.>
- 10) Separation of torque converter clutch case and transmission case. <Ref. to AT-58, REMOVAL, Torque Converter Clutch Case.>
- 11) Remove the oil pump housing. <Ref. to AT-62, REMOVAL, Oil Pump.>
- 12) Take out the high clutch and reverse clutch assembly. <Ref. to AT-87, REMOVAL, High Clutch and Reverse Clutch.>

- 13) Take out the front sun gear and the thrust bearing.

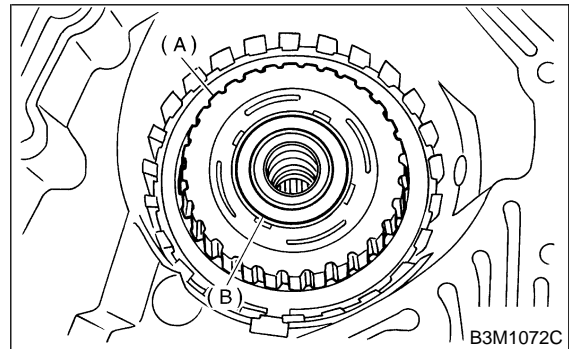

- (A) Front sun gear
- (B) Thrust needle bearing

- 14) Pull out leaf spring.

#### NOTE:

- Be careful not to bend leaf spring during removal.
- Remove it while pressing down on lower leaf spring.

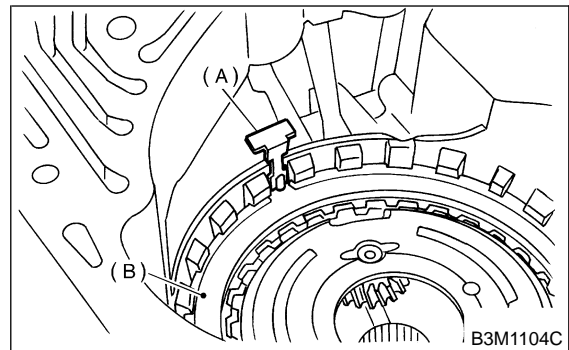

- (A) Leaf spring
- (B) Retaining plate

- 15) Remove snap ring and thrust needle bearing.

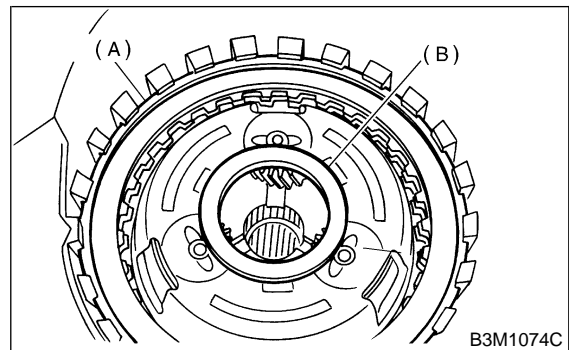

- (A) Snap ring
- (B) Thrust needle bearing

16) Take out retaining plate, drive plate and driven plate of 2-4 brake.

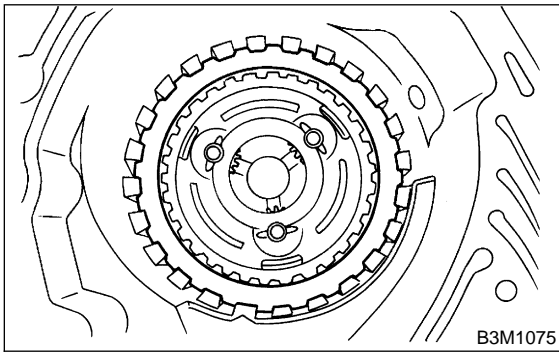

17) Take out the thrust needle bearing, planetary gear assembly and the low clutch assembly.

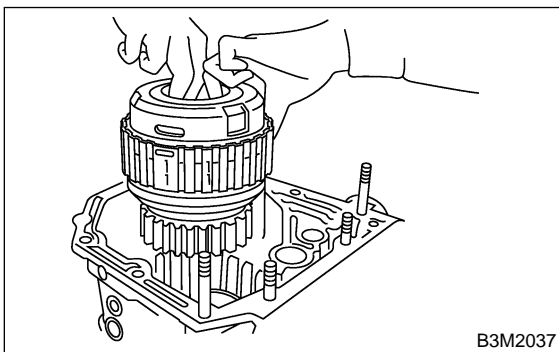

## B: INSTALLATION S510212A11

1) Install planetary gear and low clutch assembly to transmission case.

Install carefully while rotating the low clutch and planetary gear assembly slowly paying special attention not to damage the seal ring.

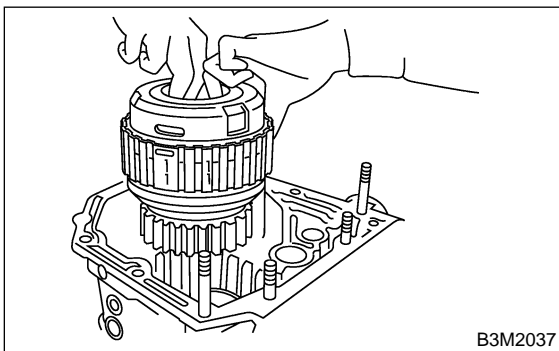

2) Install leaf spring of 2-4 brake.

NOTE:

Be careful not to mistake the location of the leaf spring to be inserted.

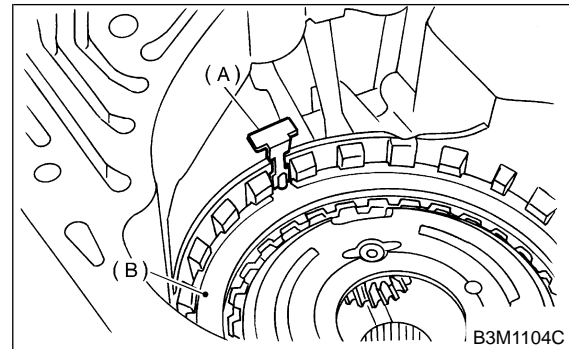

- (A) Leaf spring
- (B) Retaining plate

3) Install thrust needle bearing and snap ring.

NOTE:

Install thrust needle bearing in the correct direction.

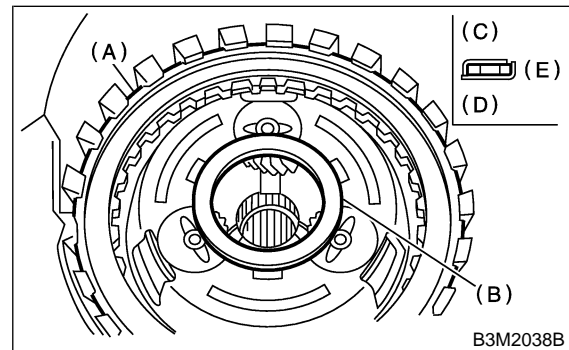

- (A) Snap ring
- (B) Thrust needle bearing
- (C) Up side
- (D) Down side
- (E) Outside

4) Install front sun gear and thrust needle bearing.  
5) Install the high clutch hub and thrust needle bearing.

Attach the thrust needle bearing to the hub with vaseline and install the hub by correctly engaging the splines of the front planetary carrier.

NOTE:

Install thrust needle bearing in the correct direction.

# PLANETARY GEAR AND LOW CLUTCH

Automatic Transmission

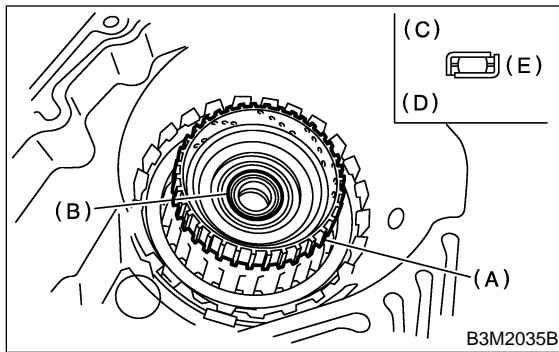

- (A) High clutch hub
- (B) Thrust needle bearing
- (C) Up side
- (D) Down side
- (E) Outside

6) Install the high clutch assembly.

### NOTE:

Correctly engage the high clutch hub and clutch splines.

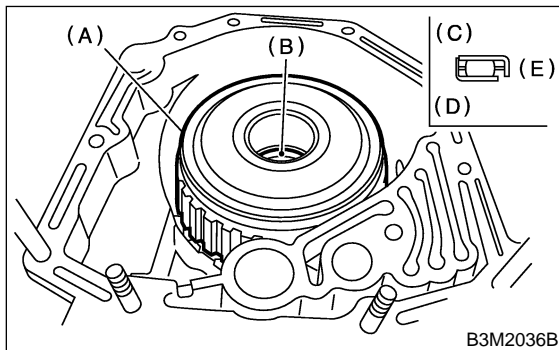

- (A) High clutch and reverse clutch assembly
- (B) Thrust needle bearing
- (C) Up side
- (D) Down side
- (E) Outside

- 7) Install oil pump housing assembly with gasket.
- 8) Install torque converter clutch case. <Ref. to AT-59, INSTALLATION, Torque Converter Clutch Case.>
- 9) Insert inhibitor switch and transmission connector into stay.
- 10) Install air breather hose. <Ref. to AT-28, INSTALLATION, Air Breather Hose.>
- 11) Install oil cooler pipes. <Ref. to AT-30, INSTALLATION, Oil Cooler Pipes.>
- 12) Install the oil charger pipe with O-ring. <Ref. to AT-29, INSTALLATION, Oil Charger Pipe.>
- 13) Insert the input shaft while turning lightly by hand.

### CAUTION:

Be careful not to damage the bushing.

Normal protrusion A:  
50 — 55 mm (1.97 — 2.17 in)

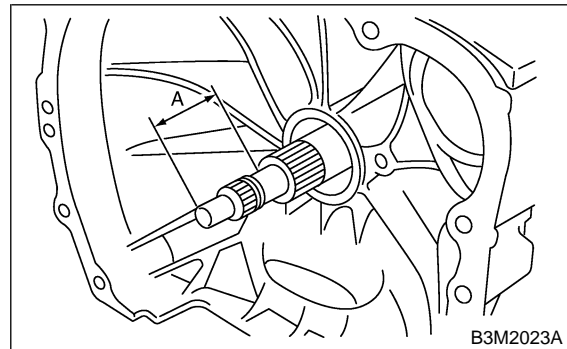

14) Install the torque converter clutch assembly. <Ref. to AT-35, INSTALLATION, Torque Converter Clutch Assembly.>

### C: DISASSEMBLY S510212A06

1) Remove snap ring from the low clutch drum.

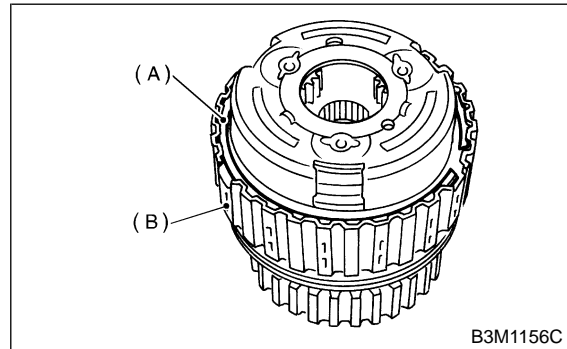

- (A) Snap ring
- (B) Low clutch drum

2) Take out front planetary carrier.

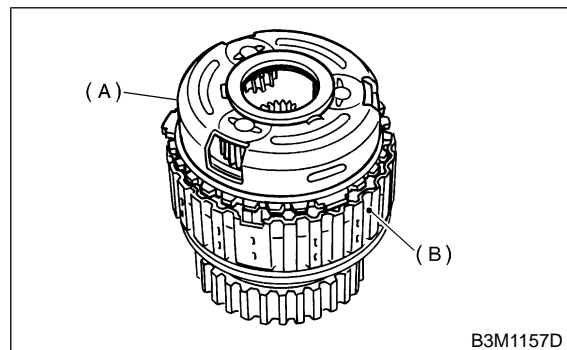

- (A) Front planetary carrier
- (B) Low clutch drum

3) Take out rear sun gear.

# PLANETARY GEAR AND LOW CLUTCH

Automatic Transmission

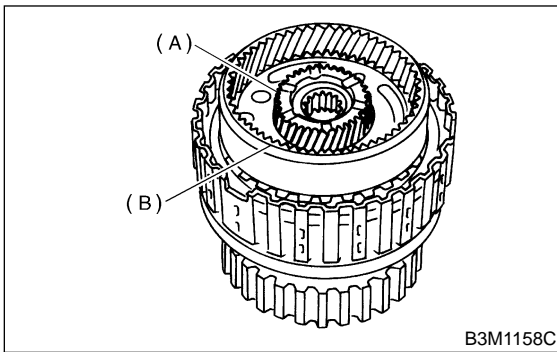

- (A) Rear sun gear
- (B) Rear planetary carrier

4) Take out rear planetary carrier, washer and thrust needle bearing.

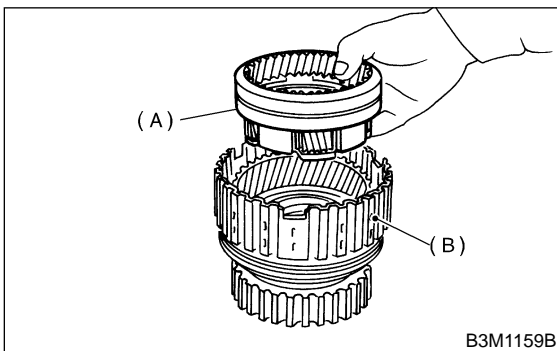

- (A) Rear planetary carrier
- (B) Low clutch drum

5) Take out rear internal gear.

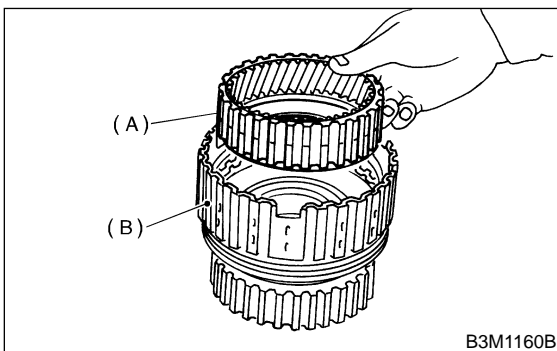

- (A) Rear internal gear
- (B) Low clutch drum

6) Remove the snap ring from the low clutch drum.

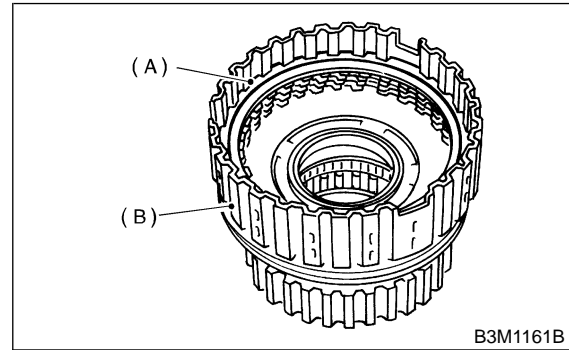

- (A) Snap ring
- (B) Low clutch drum

7) Compress the spring retainer, and remove the snap ring from the low clutch drum, by using ST1 and ST2.

ST1 498627100 SEAT  
ST2 398673600 COMPRESSOR

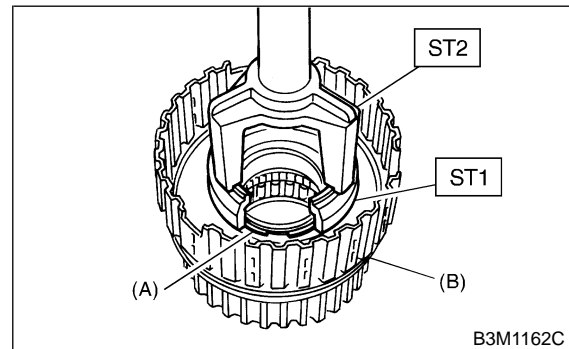

- (A) Snap ring
- (B) Low clutch drum

8) Remove one-way clutch. <Ref. to AT-104, REMOVAL, One-way Clutch.>

Install the one-way clutch inner race to the low clutch drum, and apply compressed air to remove the low clutch piston.

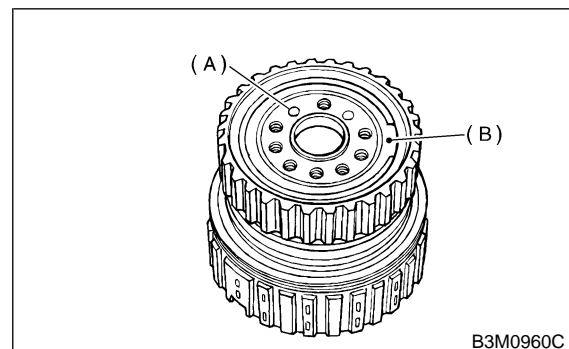

- (A) Apply compressed air
- (B) One-way clutch inner race

9) Remove the one-way clutch inner race.

# PLANETARY GEAR AND LOW CLUTCH

Automatic Transmission

10) Remove the one-way clutch after taking out the snap ring.

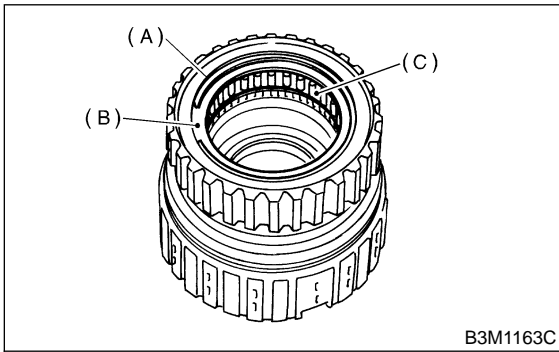

- (A) Snap ring
- (B) Plate
- (C) One-way clutch

11) Remove the needle bearing after taking out the snap ring.

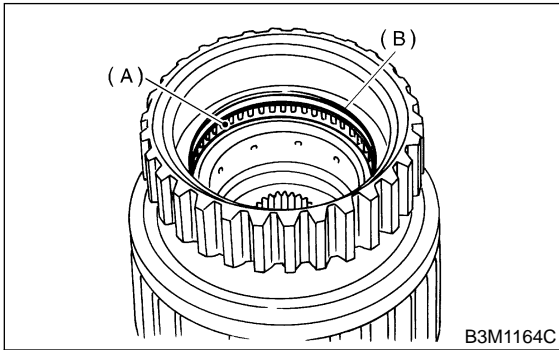

- (A) Needle bearing
- (B) Snap ring

## D: ASSEMBLY S510212A02

- 1) Install lathe cut seal ring to low clutch piston.
- 2) Fit the low clutch piston to the low clutch drum.

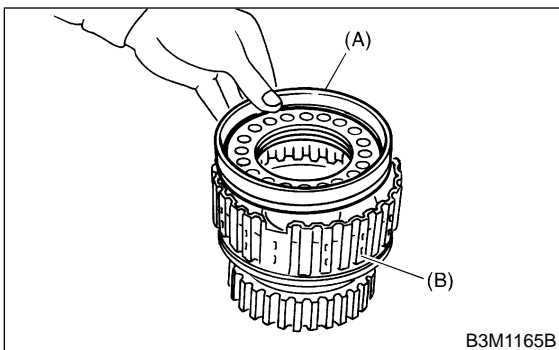

- (A) Low clutch piston
- (B) Low clutch drum

3) Install spring retainer to low clutch piston.

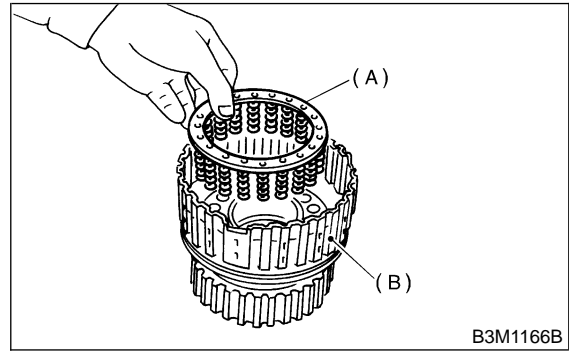

- (A) Spring retainer
- (B) Low clutch drum

4) Install ST to low clutch drum.  
ST 498437100 LOW CLUTCH PISTON GUIDE

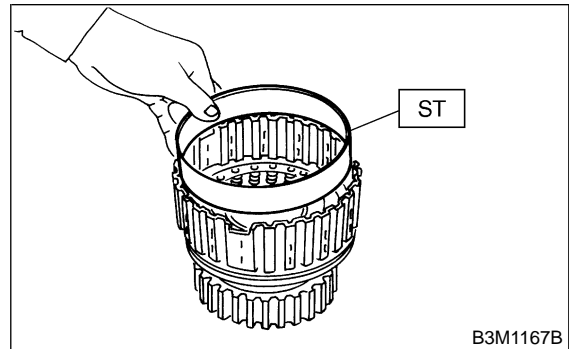

5) Set the cover on the piston with a press using ST1 and ST2, and attach the snap ring.

### NOTE:

- Be careful not to fold cover seal during installation.
- After installing snap ring, remove ST1, ST2 and ST3.

ST1 498627100 SEAT  
ST2 398673600 COMPRESSOR  
ST3 498437100 LOW CLUTCH PISTON GUIDE

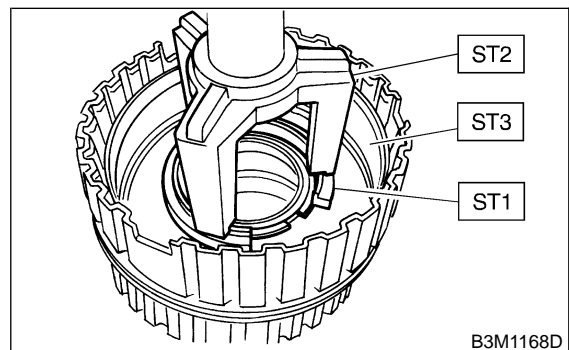

6) Install the dish plate, driven plates, drive plates, and retaining plate, and secure with the snap ring.

**NOTE:**

Pay attention to the orientation of the dish plate.

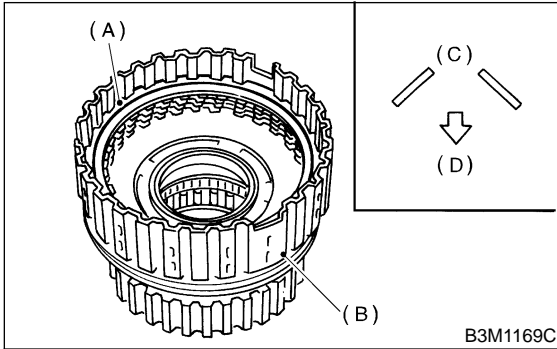

- (A) Snap ring
- (B) Low clutch drum
- (C) Dish plate
- (D) Low clutch piston side

7) Check the low clutch for operation.

- (1) Remove one-way clutch. <Ref. to AT-104, REMOVAL, One-way Clutch.>
- (2) Set the one-way clutch inner race, and apply compressed air for checking.

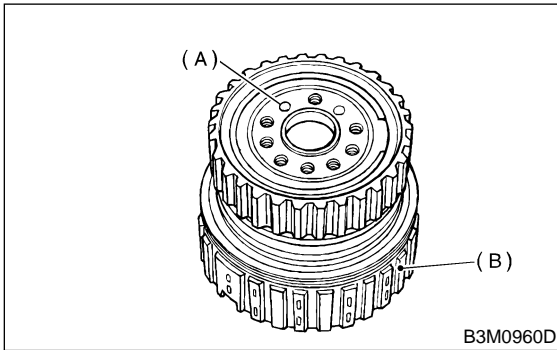

- (A) Apply compressed air
- (B) Low clutch drum

8) Checking low clutch clearance. <Ref. to AT-99, INSPECTION, Planetary Gear and Low Clutch.>

9) Install washer to rear internal gear.

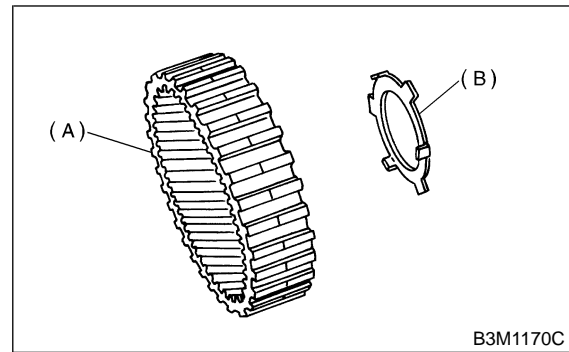

- (A) Rear internal gear
- (B) Washer

10) Install rear internal gear.

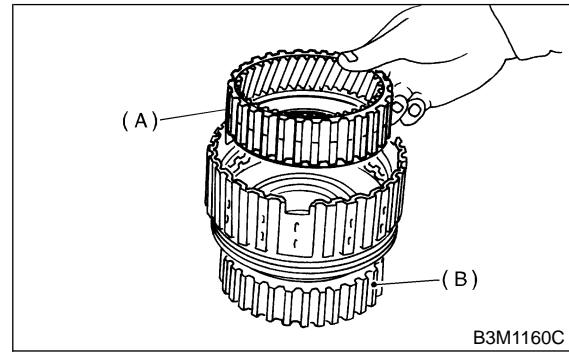

- (A) Rear internal gear
- (B) Low clutch drum

11) Install thrust needle bearing.

**NOTE:**

Install thrust needle bearing in the correct direction.

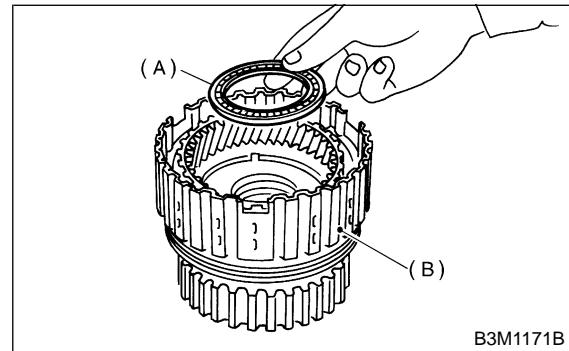

- (A) Thrust needle bearing
- (B) Low clutch drum

12) Install washer to rear planetary carrier.

**NOTE:**

Make sure washer tooth is inserted into hole on planetary carrier.

# PLANETARY GEAR AND LOW CLUTCH

Automatic Transmission

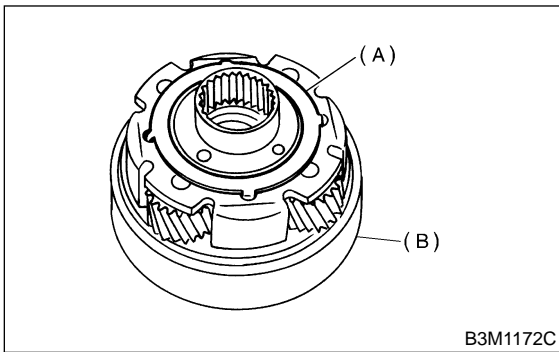

- (A) Washer
- (B) Rear planetary carrier

13) Install rear planetary carrier to low clutch drum.

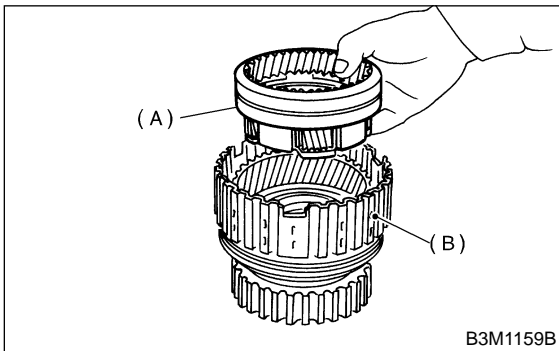

- (A) Rear planetary carrier
- (B) Low clutch drum

14) Install thrust needle bearing to rear planetary carrier.

NOTE:

Install thrust needle bearing in the correct direction.

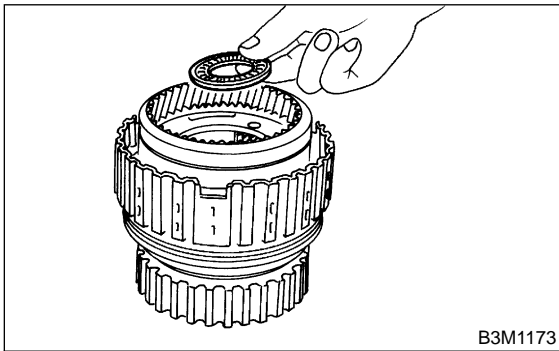

15) Install rear sun gear.

NOTE:

Pay attention to the orientation of the rear sun gear.

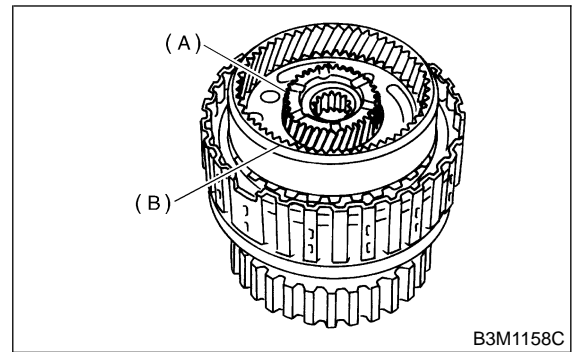

- (A) Rear sun gear
- (B) Rear planetary carrier

16) Install thrust needle bearing to front planetary carrier.

NOTE:

Pay attention to the orientation of the thrust needle bearing.

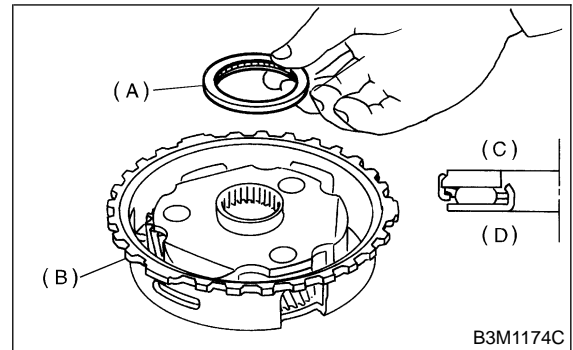

- (A) Thrust needle bearing
- (B) Front planetary carrier
- (C) Rear sun gear side
- (D) Front planetary carrier side

17) Install front planetary carrier to low clutch drum.

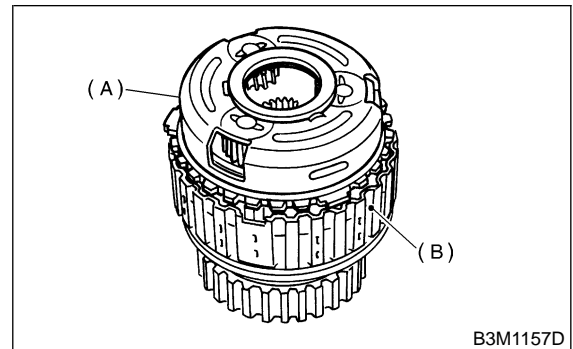

- (A) Front planetary carrier
- (B) Low clutch drum

18) Install snap ring to low clutch drum.

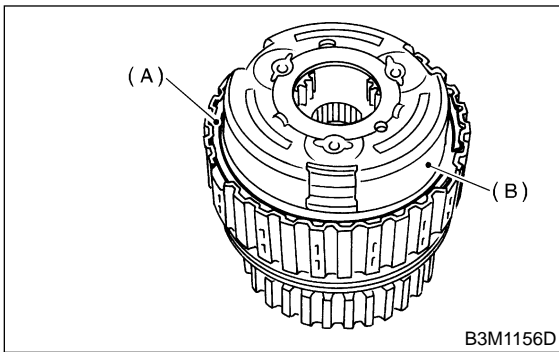

- (A) Snap ring
- (B) Front planetary carrier

19) Install the needle bearing, and secure with the snap ring.

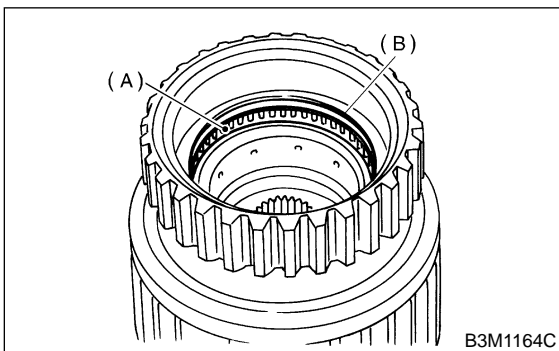

- (A) Needle bearing
- (B) Snap ring

20) Install the one-way clutch, one-way clutch inner race and plate, and secure with the snap ring.

**NOTE:**

Set the inner race. Make sure that the forward clutch is free in the clockwise direction and locked in the counterclockwise direction, as viewed from the front of the vehicle.

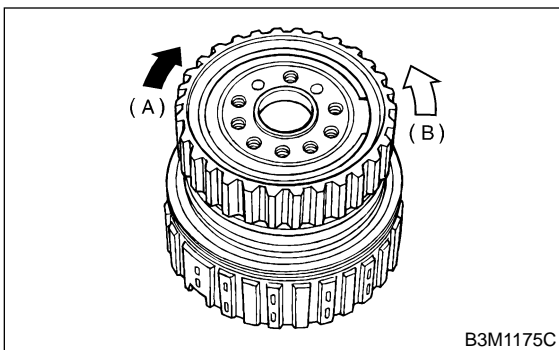

- (A) Locked
- (B) Free

**E: INSPECTION** S510212A10

- Drive plate facing for wear and damage
- Snap ring for wear, return spring for breakage or setting, and spring retainer for deformation

- Lip seal and lathe cut seal ring for damage
- Piston check ball for operation
- Measure the total end play and adjust to within specifications.

<Ref. to AT-66, ADJUSTMENT, Oil Pump.>

1) Inspect clearance between retaining plate and operation of the low clutch.

**NOTE:**

Before measuring clearance, place the same thickness of shim on both sides to prevent retaining plate from tilting.

**Standard value:**

**0.7 — 1.1 mm (0.028 — 0.043 in)**

**Allowable limit:**

**1.6 mm (0.063 in)**

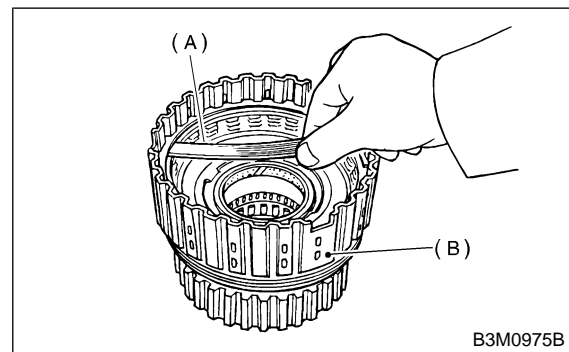

- (A) Thickness gauge
- (B) Low clutch drum

If the clearance is out of the specified range, select a proper retaining plate so that the standard clearance can be obtained.

Available retaining plates	
Part No.	Thickness mm (in)
31567AA830	3.8 (0.150)
31567AA840	4.0 (0.157)
31567AA850	4.2 (0.165)
31567AA860	4.4 (0.173)
31567AA870	4.6 (0.181)