

18. Fuel S175052

A: OPERATION S175052A16

1. RELEASING OF FUEL PRESSURE

S175052A1601

WARNING:

- Place "NO FIRE" signs near the working area.

- Be careful not to spill fuel on the floor.

1) Disconnect connector from fuel pump relay.

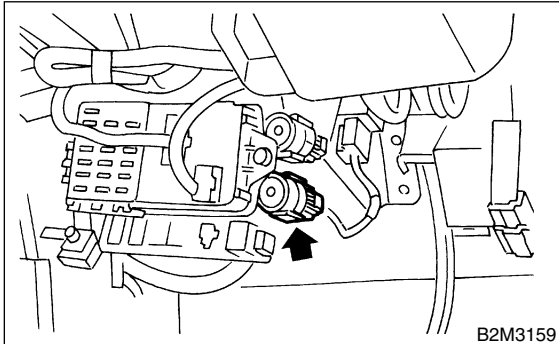

- 2) Start the engine and run it until it stalls.
- 3) After the engine stalls, crank it for five more seconds.
- 4) Turn ignition switch to OFF.

2. DRAINING FUEL S175052A1603

WARNING:

- Place "NO FIRE" signs near the working area.

- Be careful not to spill fuel on the floor.

- 1) Set vehicle on the lift.
- 2) Disconnect battery ground cable.

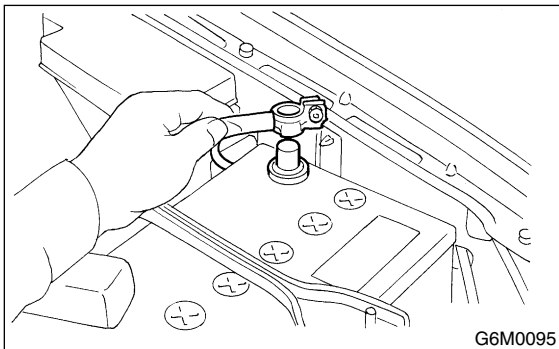

- 3) Lift-up the vehicle.
- 4) Remove front right side fuel tank cover.

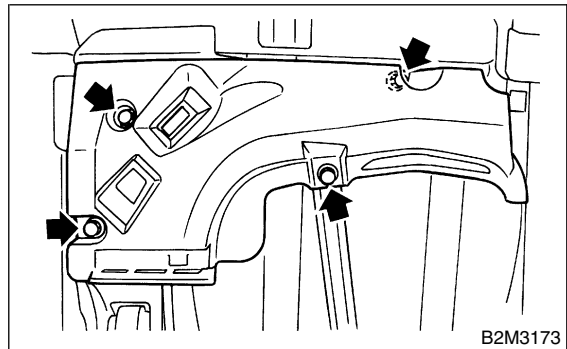

- 5) Drain fuel from fuel tank.
Set a container under the vehicle and remove drain plug from fuel tank.

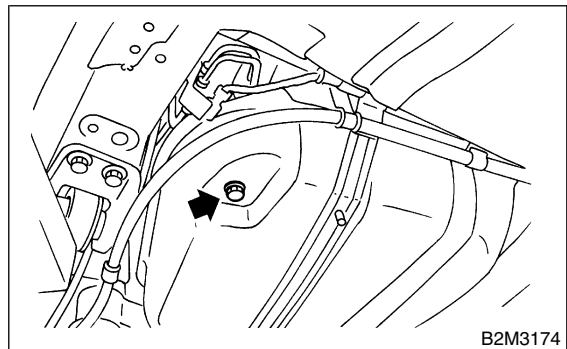

- 6) Tighten fuel drain plug and install front right side tank cover.

Tightening torque:
26 N·m (2.65 kgf·m, 19.2 ft·lb)

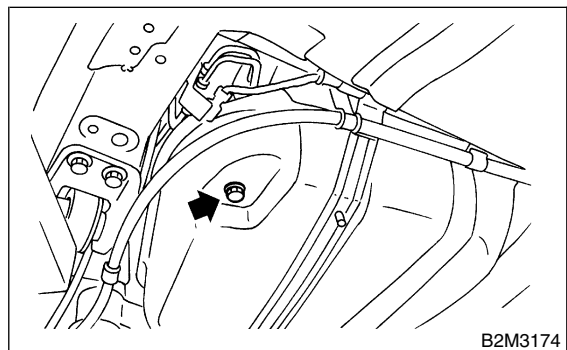

Tightening torque:
18 N·m (1.8 kgf·m, 13.0 ft·lb)

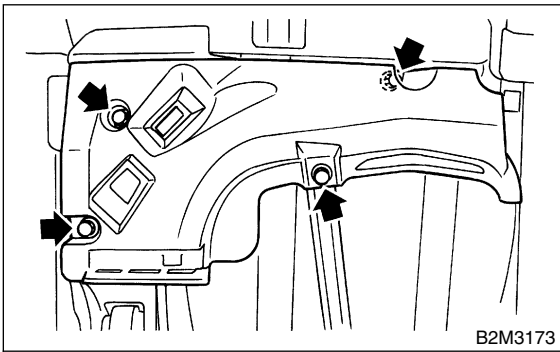

- 7) Lower the vehicle.
- 8) Remove sub service hole cover.

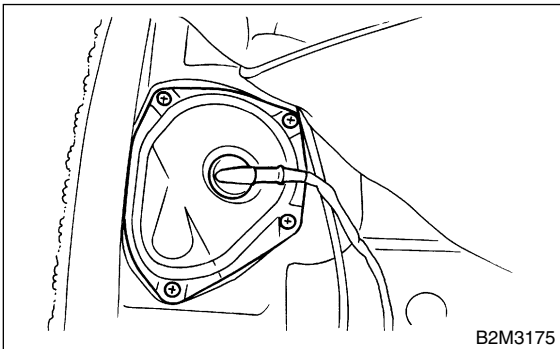

- 9) Disconnect connector from fuel sub level sensor.

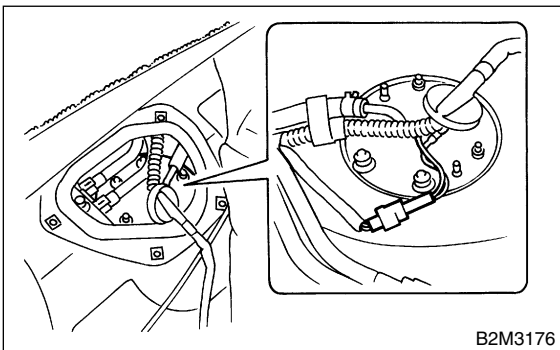

- 10) Disconnect fuel jet pump hose.

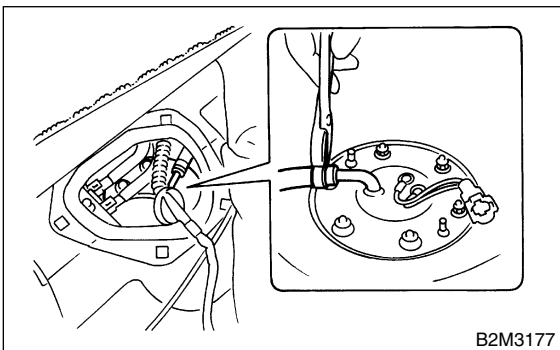

- 11) Remove fuel sub level sensor.

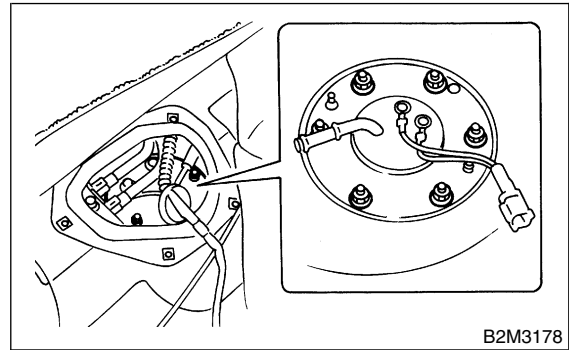

- 12) Drain fuel from fuel tank by using hand pump.

WARNING:
Do not use a motor pump when draining fuel.

- 13) After draining fuel, reinstall fuel sub level sensor.

Tightening torque:
T: 4.4 N·m (0.45 kgf·m, 3.3 ft·lb)

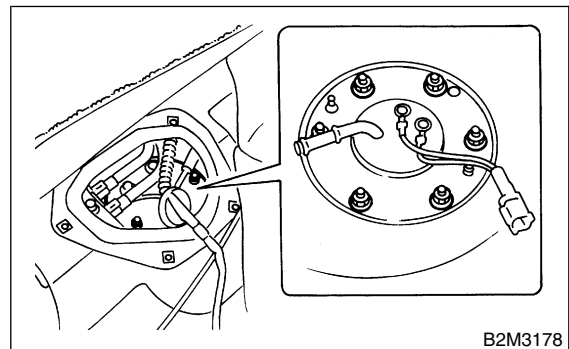

NOTE:
 If you have not removed fuel tank yet, proceed with the procedure below for installation.

- (1) Connect fuel jet pump hose.

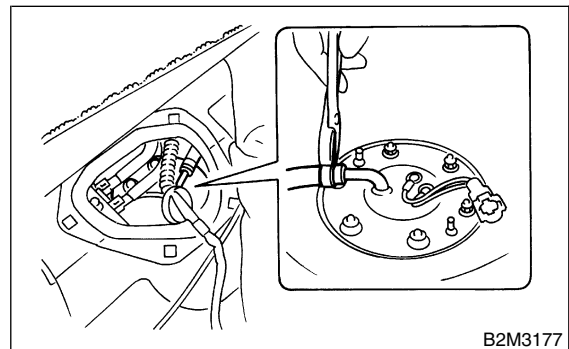

- (2) Connect connector from fuel sub level sensor.

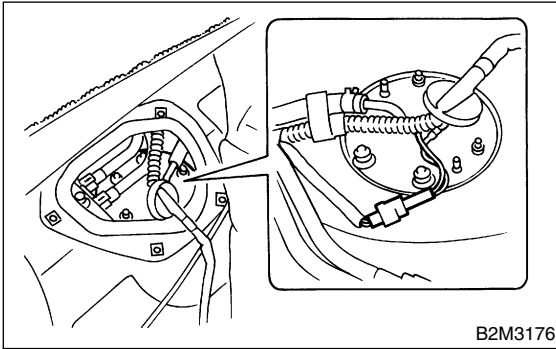

- (3) Install sub service hole cover.

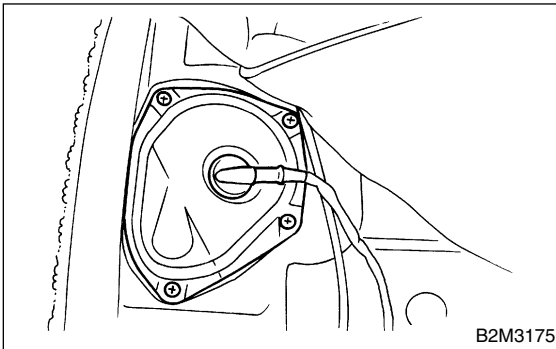

- (4) Set rear seat and floor mat.