

## 16. Camshaft S143092

### A: REMOVAL S143092A18

- 1) Remove crankshaft pulley. <Ref. to ME(H6)-39, REMOVAL, Crankshaft Pulley.>
- 2) Remove front chain cover. <Ref. to ME(H6)-40, REMOVAL, Front Chain Cover.>
- 3) Remove timing chain assembly. <Ref. to ME(H6)-42, REMOVAL, Timing Chain Assembly.>
- 4) Remove camshaft sprockets. <Ref. to ME(H6)-47, REMOVAL, Camshaft Sprocket.>
- 5) Remove crankshaft sprocket. <Ref. to ME(H6)-48, REMOVAL, Crankshaft Sprocket.>
- 6) Remove rear chain cover. <Ref. to ME(H6)-49, REMOVAL, Rear Chain Cover.>
- 7) Remove rocker cover (RH).

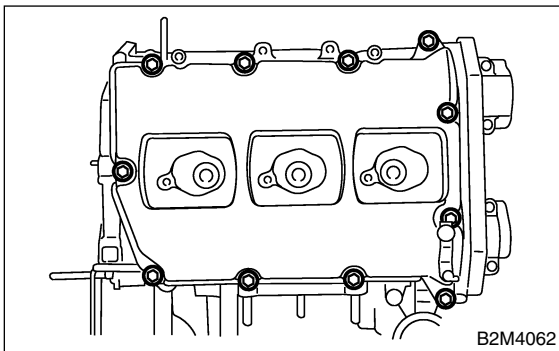

- 8) Loosen front camshaft cap bolts equally, a little at a time in numerical sequence shown in the figure (RH).

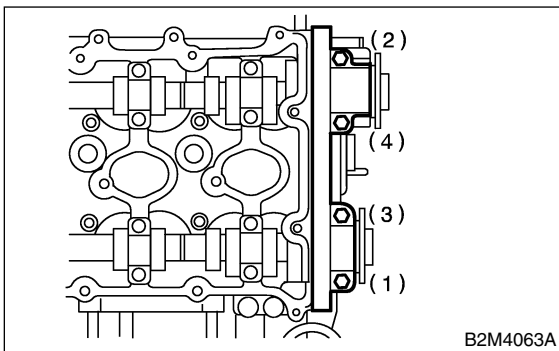

- 9) Remove camshaft cap and intake camshaft (RH).

- 10) Loosen camshaft cap bolts equally, a little at a time in the numerical sequence shown in the figure.

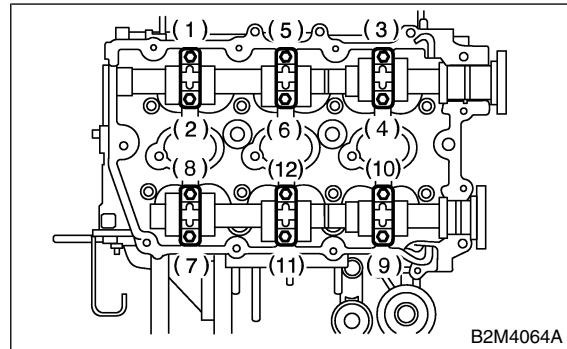

- 11) Remove camshaft cap and exhaust camshaft (RH).

**CAUTION:**  
Arrange camshaft caps in order so that they can be installed in their original position.

- 12) Remove plug (LH).

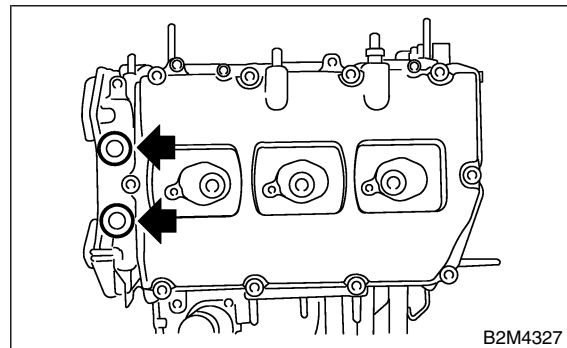

- 13) Similarly, remove left-hand camshafts and related parts.

### B: INSTALLATION S143092A11

- 1) Apply a coat of engine oil to camshaft journals and install camshaft.

**CAUTION:**  
When installing camshaft, adjust camshaft front flange knock pin (A) position as follows:  
LH side: 12 o'clock  
RH side: 10 o'clock

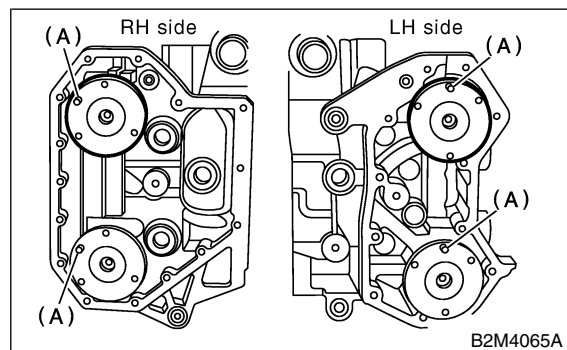

# CAMSHAFT

Mechanical

2) Install camshaft cap.

(1) Apply fluid packing sparingly to back of front camshaft cap shown in the figure.

**CAUTION:**

**Do not apply fluid packing excessively. Failure to do so may cause excess packing to come out and flow toward oil seal, resulting in oil leaks.**

**Fluid packing:**

**THREE BOND 1280B**

**Fluid packing application diameter:**

**2.0±0.5 mm (0.079±0.020 in)**

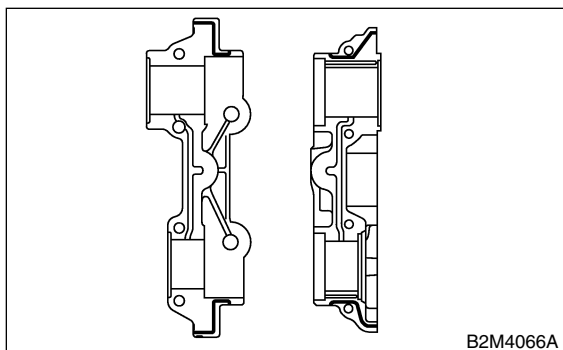

(2) Apply engine oil to cap bearing surface and install cap on camshaft.

(3) Tighten the camshaft cap bolts in the numerical sequence shown in the figure.

**Tightening torque:**

**16 N·m (1.6 kgf·m, 11.6 ft·lb)**

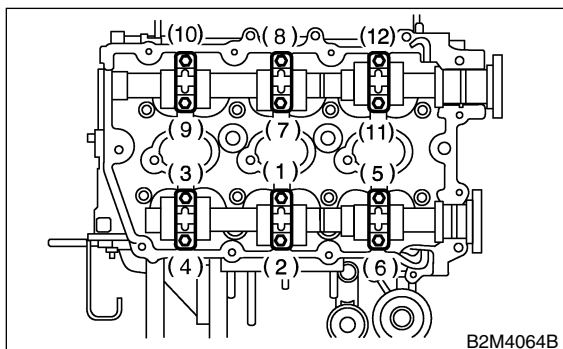

(4) Tighten the front camshaft cap bolts in the numerical sequence shown in the figure.

**Tightening torque:**

**9.8 N·m (1.0 kgf·m, 7.2 ft·lb)**

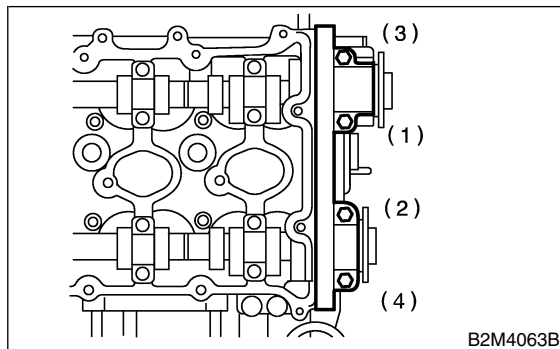

3) Install rocker cover.

(1) Apply fluid packing sparingly to matching surface of cylinder heads and rocker covers shown in the figure.

**CAUTION:**

**Do not apply fluid packing excessively. Doing so may cause excess packing to come out and flow toward oil seal, resulting in oil leaks.**

**Fluid packing:**

**THREE BOND 1280B**

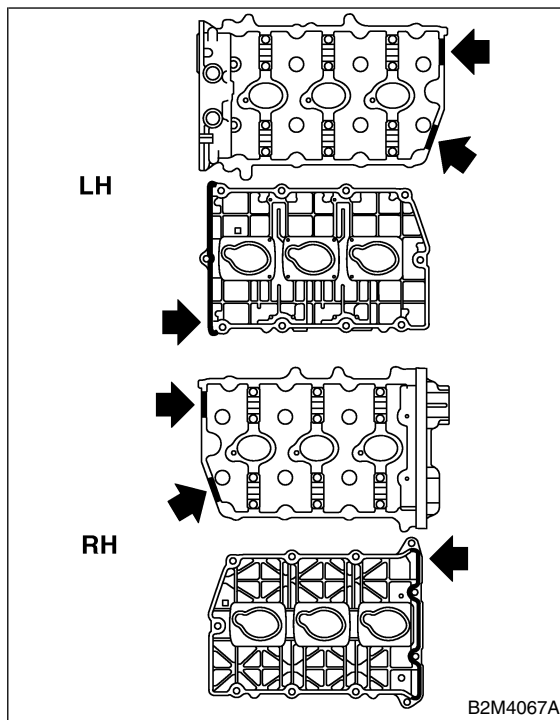

(2) Tighten the rocker cover bolts in the numerical order shown in the figure.

**Tightening torque:**

**6.4 N·m (0.64 kgf-m, 4.6 ft-lb)**

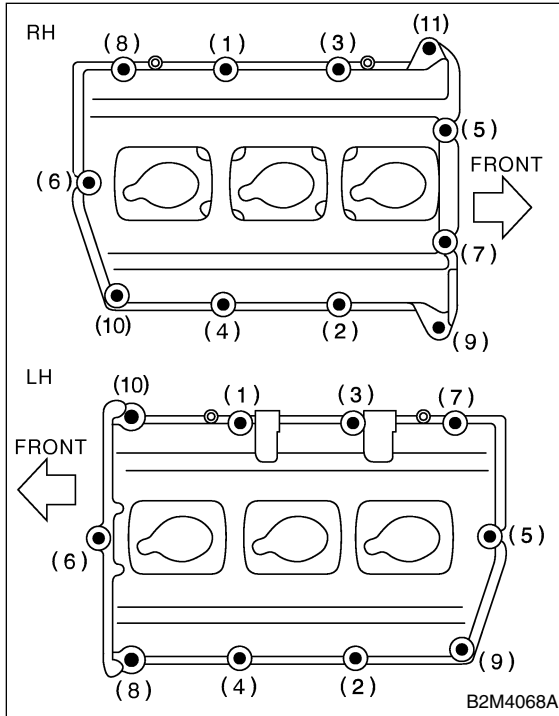

- 4) Install rear chain cover. <Ref. to ME(H6)-49, INSTALLATION, Rear Chain Cover.>
- 5) Install crankshaft sprocket. <Ref. to ME(H6)-48, INSTALLATION, Crankshaft Sprocket.>
- 6) Install camshaft sprockets. <Ref. to ME(H6)-47, INSTALLATION, Camshaft Sprocket.>
- 7) Install timing chain assembly. <Ref. to ME(H6)-43, INSTALLATION, Timing Chain Assembly.>
- 8) Install front chain cover. <Ref. to ME(H6)-40, INSTALLATION, Front Chain Cover.>
- 9) Install crankshaft pulley. <Ref. to ME(H6)-39, INSTALLATION, Crankshaft Pulley.>

## C: INSPECTION S143092A10

### 1. CAMSHAFT S143092A1001

1) Measure the bend, and repair or replace if necessary.

**Limit:**

**0.020 mm (0.0008 in)**

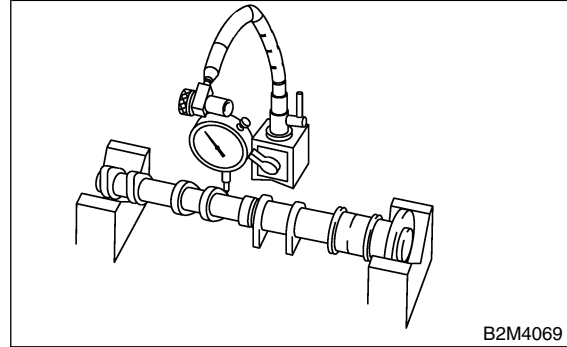

- 2) Check journal for damage and wear. Replace if faulty.
- 3) Measure outside diameter of camshaft journal. If the journal diameter is not as specified, check the oil clearance.

	Camshaft journal	
	Front	Center, rear
Standard	37.946 — 37.963 mm (1.4939 — 1.4946 in)	27.946 — 27.963 mm (1.1002 — 1.1009 in)

- 4) Measurement of the camshaft journal oil clearance
  - (1) Clean the bearing caps and camshaft journals.
  - (2) Place the camshafts on the cylinder head. (Without installing valve rocker.)
  - (3) Place plastigauge across each of the camshaft journals.
  - (4) Install the bearing caps.

**CAUTION:**

**Do not turn the camshaft.**

- (5) Remove the bearing caps.

# CAMSHAFT

Mechanical

(6) Measure the widest point of the plastigauge on each journal.

If the oil clearance exceeds the limit, replace the camshaft. If necessary, replace the camshaft caps and cylinder head as a set.

**Standard oil clearance:**

**0.037 — 0.072 mm (0.0015 — 0.0028 in)**

**Limit:**

**0.10 mm (0.0039 in)**

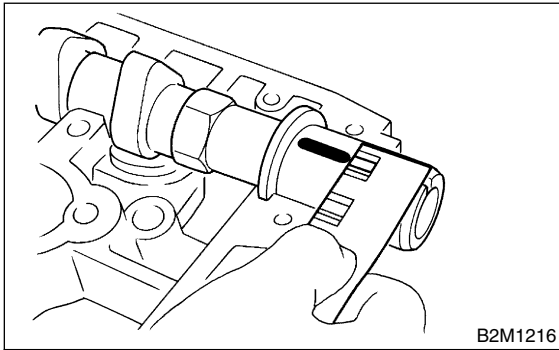

(7) Completely remove the plastigauge.

5) Check cam face condition; remove minor faults by grinding with oil stone. Measure the cam height H; replace if the limit has been exceeded.

**Cam height: H**

**Standard:**

**Intake:**

**46.05 — 46.15 mm (1.8130 — 1.8169 in)**

**Exhaust:**

**45.55 — 45.65 mm (1.7933 — 1.7972 in)**

**Limit:**

**Intake:**

**45.95 mm (1.8091 in)**

**Exhaust:**

**45.45 mm (1.7894 in)**

**Cam base circle diameter A:**

**36.0 mm (1.4173 in)**

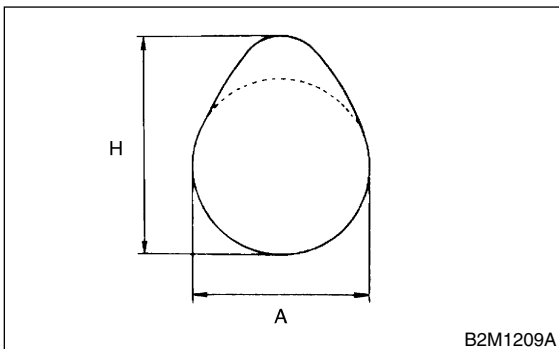

6) Measure the thrust clearance of camshaft with dial gauge. If the clearance exceeds the limit, replace caps and cylinder head as a set. If necessary replace camshaft.

**Standard:**

**Intake:**

**0.075 — 0.135 mm (0.0030 — 0.0053 in)**

**Exhaust:**

**0.048 — 0.108 mm (0.0019 — 0.0043 in)**

**Limit:**

**Intake:**

**0.155 mm (0.0061 in)**

**Exhaust:**

**0.130 mm (0.0051 in)**

