

## 1. Pre-delivery Inspection SA09719

### A: GENERAL SA09719G23

The purposes of the pre-delivery inspection (PDI) are as follows.

- Remove the additional parts used for ensuring the vehicle quality during transportation and restore the vehicle to its normal state.
- Check if the vehicle before delivery is in a normal state.
- Check for any damage or missing parts that may have taken place during transportation or storage.
- Make sure to provide a complete vehicle to the customer.

Because of the above reasons, all dealerships must always carry out the PDIs before delivering a vehicle.

In addition, all franchised shops and PDI centers must check the status of every vehicle received to identify who is responsible for any possible defects.

**B: PDI PROCEDURE** SA09719G50

Follow the procedures shown in the table below.

**Static Checks Just After Vehicle Receipt**

Step	Check point
1. Appearance check	(1) If the vehicle is covered with protective coating, visually check the vehicle body for damage and dents. (2) If the protective film has been removed, visually check the body paints for small areas of damage or stains. (3) Visually check the glass and light lenses for any damage and cracks or excessive gaps to the body sheet metal. (4) Visually check the plated parts for any damage.
2. Tire check	(1) Check the tires for damage, abnormal conditions, and dents on the wheels. (2) Check the tire air pressure.
3. Fuse installation	(1) If the vehicle is about to be delivered to the customer, attach a fuse.
4. Connection of air conditioner relay	(1) If the vehicle is about to be delivered to the customer, connect the air conditioner relay.
5. Check the doors for lock/unlock and open/close operations.	(1) Using the key, check if the door can be locked and unlocked normally. (2) Open and close the all doors to see that there are no abnormal conditions.
6. Check the trunk lid open/close operations.	(1) Operate the trunk lock release lever to check that the trunk opens normally. (2) Using the key, check if the trunk lid can be unlocked normally. (3) Open and close the trunk lid to see that there are no abnormal conditions.
7. Check the rear gate for lock/unlock and open/close operations.	(1) Using the key, check if the rear gate can be lock and unlocked normally. (2) Open and close the rear gate to see that there are no abnormal conditions. (3) Operate the power door locking switch to check that the rear gate is locked and unlocked normally.
8. Operation check of trunk lid release handle	(1) Operate the trunk lid release lever to check the trunk is unlocked normally.
9. Operation check of fuel lid opener lock release lever	(1) Operate the fuel lid opener to check that the fuel lid is unlocked normally.
10. Accessory check	Check the following accessories are provided: <ul style="list-style-type: none"> <li>● Owner's manual</li> <li>● Warranty booklet</li> <li>● Service booklet</li> <li>● Spare key</li> <li>● Jack</li> <li>● Tool set</li> <li>● Spare tire</li> </ul>
11. Operation check of hood lock release system	(1) Operate the hood lock release lever to check that the hood opens normally.
12. Battery	(1) Check the battery for any abnormal conditions such as rust and trace of battery fluid leaks.
13. Brake fluid	(1) Check the fluid amount.
14. Engine oil	(1) Check the oil amount.
15. Transmission fluid	(1) Check the fluid amount. (2) For AT, check the front differential oil.
16. AT front differential oil	(1) Check the AT front differential oil amount.
17. Coolant	(1) Check the coolant amount.
18. Clutch fluid	(1) Check the clutch fluid amount.
19. Window washer fluid	(1) Check the window washer fluid amount.
20. Hood latch check	(1) Check that the hood is closed and latched securely.
21. Keyless entry system	(1) Check that the keyless entry system operates normally.

# PRE-DELIVERY INSPECTION

## Pre-delivery Inspection

Step	Check point
22. Security system	(1) Check that the security system operates normally.
23. Seat	(1) Check the seat surfaces for smears or dirt. (2) Check the seat installation conditions and functionality.
24. Seat belt	(1) Check the seat belt installation conditions and functionality.
25. Wheel alignment	(1) Check that the wheel alignments are properly adjusted.

## Checks with the Engine Running

Step	Check point
1. Test mode connector	(1) Disconnect the test mode connector.
2. Operation check of shift lock system, key interlock, and starter interlock	(1) For a MT vehicle, check the starter interlock system operations. (2) For an AT vehicle, check the shift lock and key interlock system operations.
3. Starting condition	(1) Start the engine and check that the engine starts smoothly.
4. Exhaust system	(1) Check that the exhaust noise is normal and no leaks are found.
5. Indicator light	(1) Check that all the indicator lights operate normally.
6. Clock	(1) Check that the clock operate normally.
7. Radio	(1) Check that the radio system operates normally.
8. Cigarette lighter	(1) Check that the cigarette lighter operates normally.
9. Lighting system	(1) Check that the lighting systems operate normally.
10. Window washer	(1) Check that the window washer system operates normally.
11. Wiper	(1) Check that the wiper system operates normally.
12. Power window operation check	(1) Check the power window for correct operations.

## Dynamic Test with the Vehicle Running

Step	Check point
1. Brake test	(1) Check that the foot brake operates normally.
2. Parking brake	(1) Check that the parking brake operates normally.
3. AT shift control	(1) Check the AT shift patterns are correct.
4. Heater & ventilation	(1) Check that the heater & ventilation system operates normally.
5. Air conditioner	(1) Check that the air conditioner operates normally.
6. Cruise control	(1) Check that the cruise control system operates normally.

## Checks after Dynamic Test

Step	Check point
1. ATF level	(1) Check that the ATF level is normal.
2. Power steering fluid level	(1) Check that the power steering fluid level is normal.
3. Fluid leak check	(1) Check for fluid/oil leaks.
4. Water leak check	(1) Spray the vehicle with water and check for water leaks.
5. Appearance check 2	(1) Remove the protective coating (if any). (2) Check the body paints for damage and smears. (3) Check the plated parts for damage and rust.

## 1. APPEARANCE CHECK SA09719G5001

1) Remove any protective film from the vehicle.

### NOTE:

- Before removal of protective film, perform steam cleaning to facilitate removal. When the vehicle has parked for a long time, or when the temperature is low, heating up the body temperature with a high temperature cleaning will facilitate removal.
- For remaining glue, lightly apply guard wax or solvent (such as petroleum benzine or IPA), to the area that glue remains with a flannel shop cloth, and wipe it.
- For a surface which has traces, expose the surface to the sun for 2 or 3 hours or heat it up with a dryer at 80°C (176°F) for approximately 1 hour.

2) If there is no protective film, check the body paints for small areas of damage or stains and repair as necessary.

3) Check the window glass, door glass, and lights for any cracks or damage and repair or replace the parts as necessary.

4) Check the plated parts, such as the grilles and door knobs, for damage or loss of gloss and repair or replace the parts as necessary.

## 2. TIRE CHECK SA09719G5002

- Check the tire outer faces for any damage.
- Check the tire air pressure by referring to the following table.

Tire size	Tire inflation pressure kPa (kg/cm <sup>2</sup> , psi)	
	Front	Rear
P195/60R15	230 (2.3, 33)	220 (2.2, 32)
P205/60R15	220 (2.2, 32)	210 (2.1, 30)
R205/55R16	220 (2.2, 32)	210 (2.1, 30)
P225/60R16	210 (2.1, 30)	200 (2.0, 29)

## 3. FUSE INSTALLATION SA09719G5010

A vehicle just delivered has no fuses for the circuit to prevent battery discharge. Attach a 15 A fuse as shown in the figure.

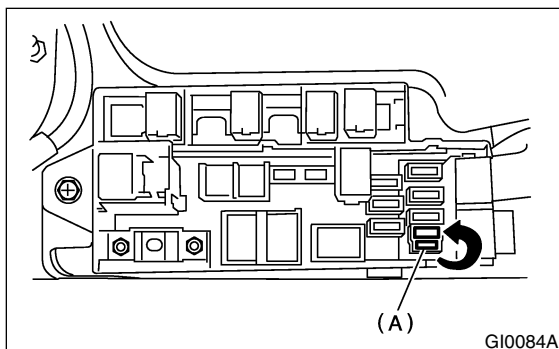

## 4. CONNECTION OF AIR CONDITIONER RELAY SA09719G5050

A vehicle just delivered has its air conditioner relay disconnected to protect the air conditioner compressor. Switch air conditioner relay position as shown in the figure below.

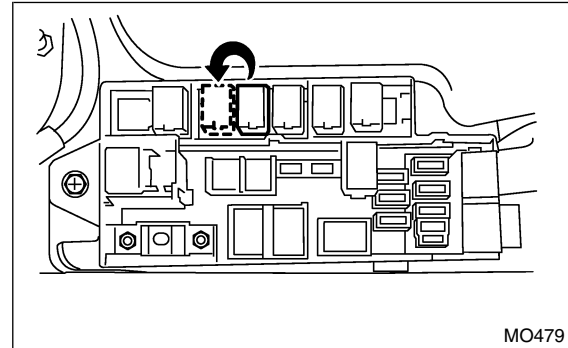

## 5. CHECK THE DOOR OPERATIONS, LOCK/UNLOCK AND OPEN/CLOSE, AS FOLLOWS. SA09719G5003

Using the key, lock and unlock the door several times to check for normal operation. Open and close the door several times for smooth movement.

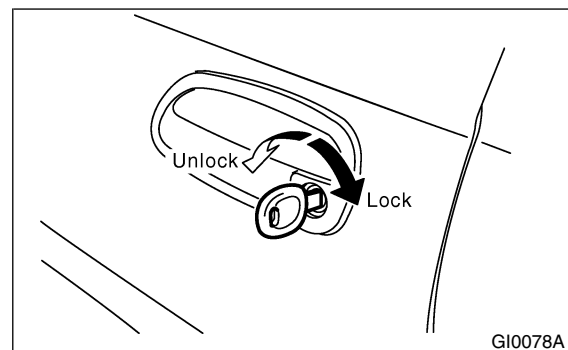

### ● Vehicles with manual door locks:

Sit in the driver seat, close the door completely, and move the lock lever to the lock position. Then, pull the inside door handle to ensure the door will not open.

# PRE-DELIVERY INSPECTION

## Pre-delivery Inspection

### ● Vehicles with power door locks:

Sit in the driver seat, close the driver's door completely, and place the power locking switch (A) to the lock position. Then pull the all inside door handles (B) to ensure that the all doors will not open.

Sit in the passenger seat, do the same procedure as for the driver seat.

For other doors, place the lock levers to the lock positions and then pull the inside door handles to ensure that the doors will not open.

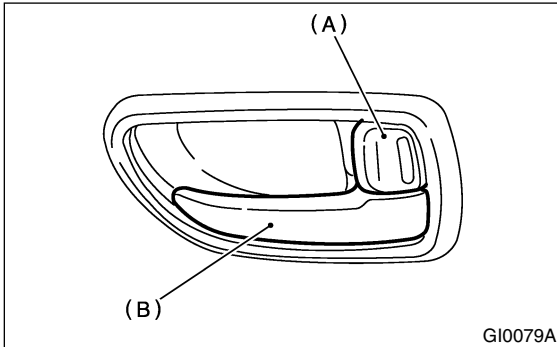

### 6. CHECK THE TRUNK LID OPERATIONS, OPEN/CLOSE, AS FOLLOWS. SA09719G5055

- Operate the trunk lock release lever and verify that the trunk lid opens.
- Using the key, open the trunk lid several times to check for normal operation.
- Open and close the trunk lid several times for smooth movement.

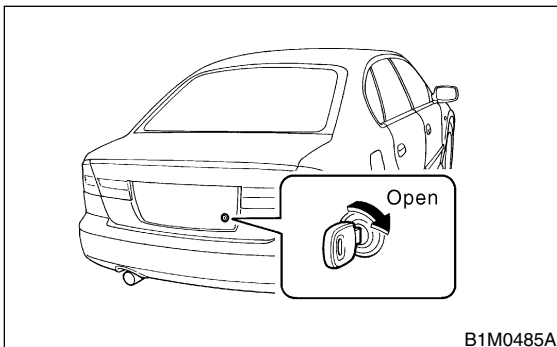

- Set the trunk lid release lever to the cancel position, and check that the trunk lid can only be opened with the key.

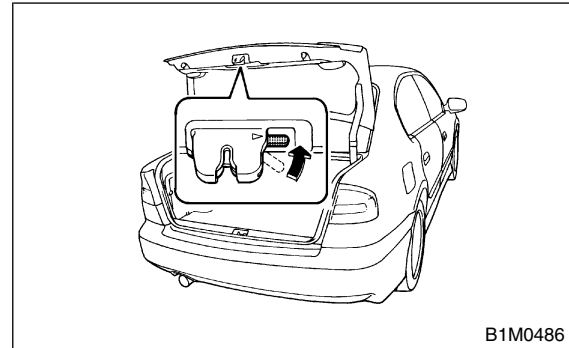

### 7. CHECK THE REAR GATE OPERATIONS, LOCK/UNLOCK AND OPEN/CLOSE, AS FOLLOWS. SA09719G5053

- Using the key, lock and unlock the rear gate several times to check for normal operation.
- Open and close the rear gate several times for smooth movement.

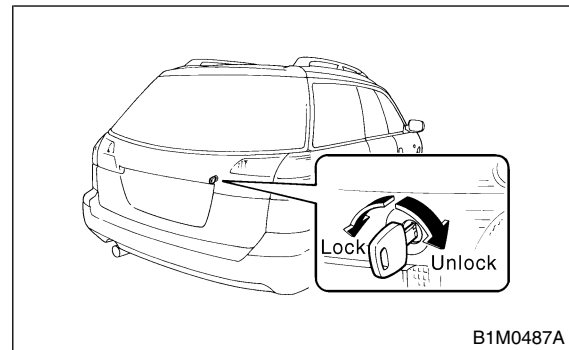

- Operate the power door locking switch to check that the rear gate is locked and unlocked normally.

**8. OPERATION CHECK OF TRUNK LID RELEASE HANDLE** SA09719G5056

1) Use a screwdriver with a thin blade. Slide the screwdriver blade from the slit aperture of the lock assembly fully to the end until you hear a click. This places the latch in the locked position.

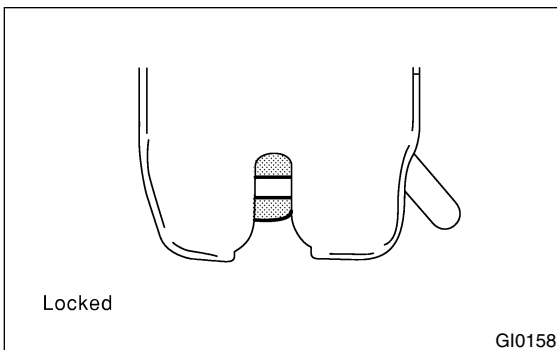
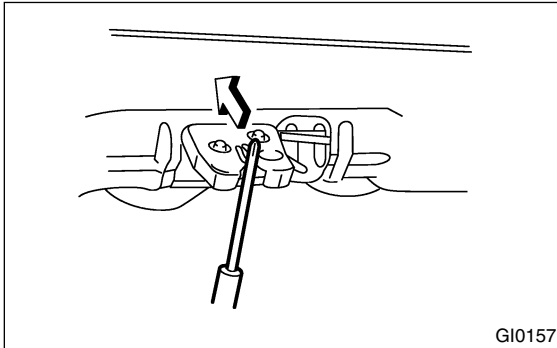

2) Move the release handle from outside the vehicle, in the direction of the arrow to check if the latch is released.

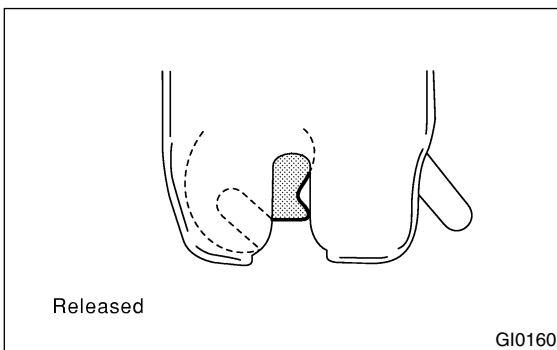
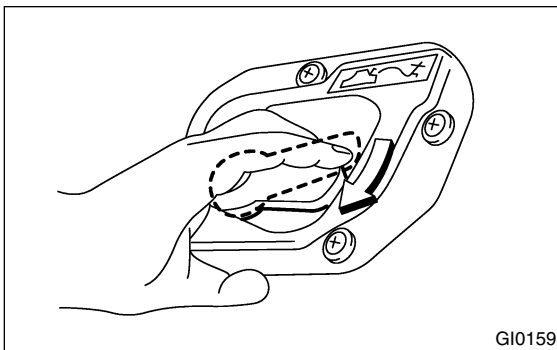

**9. OPERATION CHECK OF FUEL LID OPENER LOCK RELEASE LEVER** SA09719G5007

Operate the fuel lid opener and verify that the fuel lid opens normally. Check that the filler cap is securely closed.

**10. ACCESSORY CHECK** SA09719G5008

Check that the following accessories are provided in the luggage compartment or cargo area.

- Owner's manual
- Warranty booklet
- Service booklet
- Spare key
- Jack
- Tool set
- Spare tire

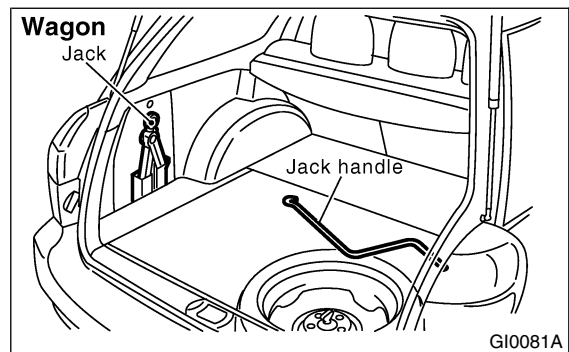
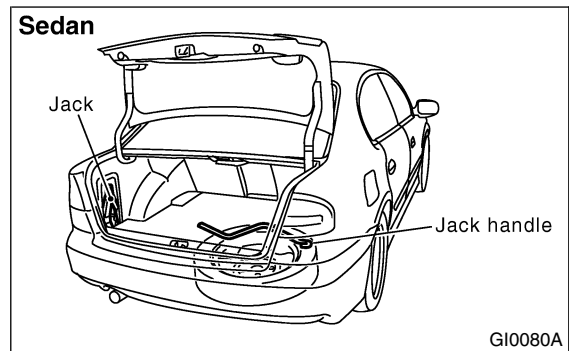

# PRE-DELIVERY INSPECTION

Pre-delivery Inspection

## 11. OPERATION CHECK OF HOOD LOCK RELEASE SYSTEM SA09719G5009

Unlatch and open the hood while checking that no abnormal conditions are found. Then, support the hood with the hood stay.

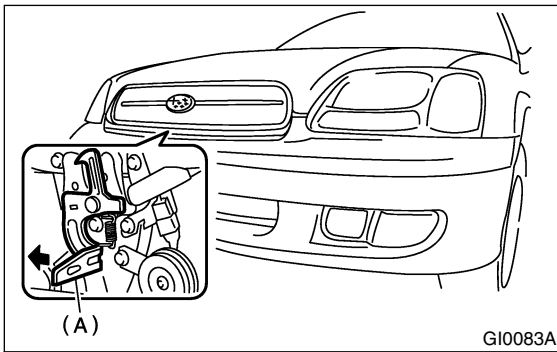
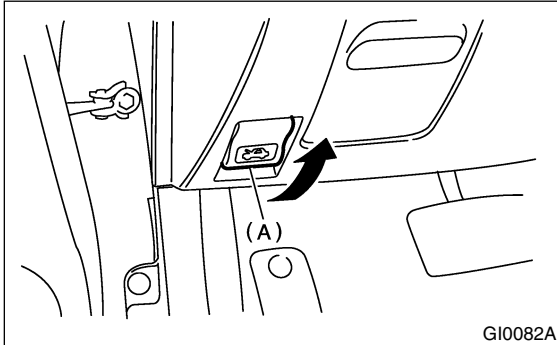

## 12. BATTERY SA09719G5012

Check the battery terminals to make sure that no rust or corruptions due to fluid leaks are found. Check that the battery tent is securely tightened.

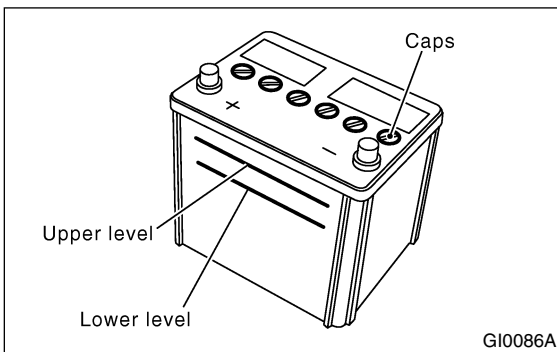

## 13. BRAKE FLUID SA09719G5013

Check the brake fluid amount. If the amount is insufficient, carry out a brake line test to identify brake fluid leaks and check the brake operation. After that, refill the brake fluid tank with the specified type of fluid.

## 14. ENGINE OIL SA09719G5014

Check the engine oil amount. If the amount is insufficient, check that no leaks are found. Then, add the necessary amount of the specified engine oil.

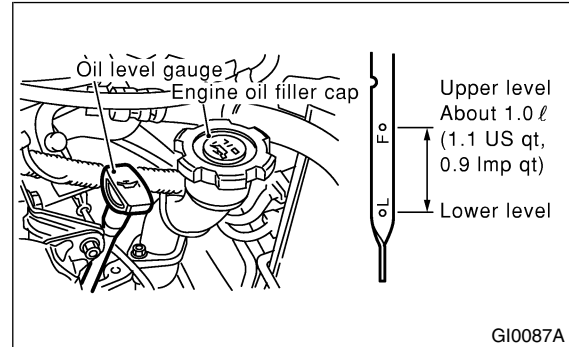

## 15. TRANSMISSION FLUID SA09719G5015

Check the transmission fluid amount. If the amount is insufficient, check that no leaks are found. Then, add the necessary amount of the specified fluid.

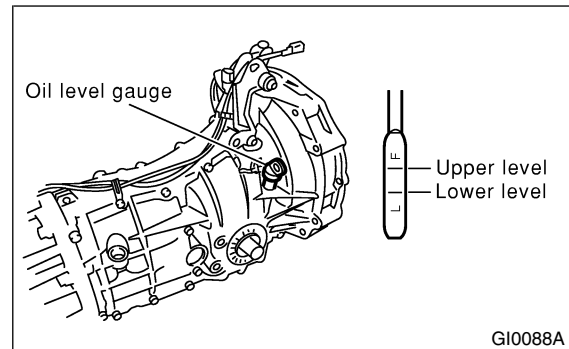

## 16. AT FRONT DIFFERENTIAL OIL SA09719G5016

Check the AT front differential oil amount. If the amount is insufficient, check that no leaks are found. Then, add the necessary amount of the specified AT front differential oil.

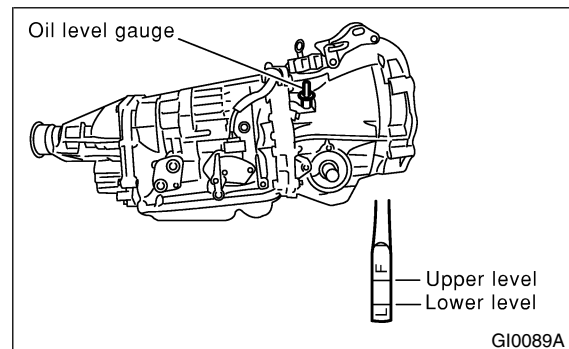

## 17. COOLANT SA09719G5017

Check the coolant amount on the reservoir. If the amount is insufficient, check that no leaks are found. Then, add the necessary amount of coolant with the specified concentration.

## 18. CLUTCH FLUID SA09719G5018

Check the clutch fluid amount. If the amount is insufficient, check that no leaks are found. Then, add the necessary amount of the specified fluid.

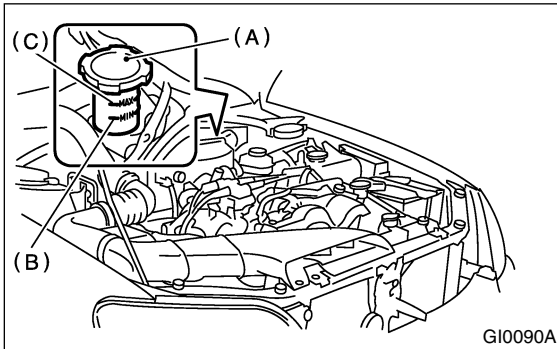

## 19. WINDOW WASHER FLUID SA09719G5019

Check the window washer fluid amount. If the amount is insufficient, check that no leaks are found. Then, add the necessary amount of washer fluid commercially available.

## 20. HOOD LATCH CHECK SA09719G5020

Retract the hood stay and close the hood. Check that the hood is securely latched.

## 21. KEYLESS ENTRY SYSTEM SA09719G5021

Check the keyless entry system operations as follows.

- Open all the door windows fully.
- Remove the key from the ignition switch and close all the doors including rear gate (wagon).
- Press the “LOCK/ARM” button on the transmitter momentarily once and check if all the doors are locked and the horn chirps once.

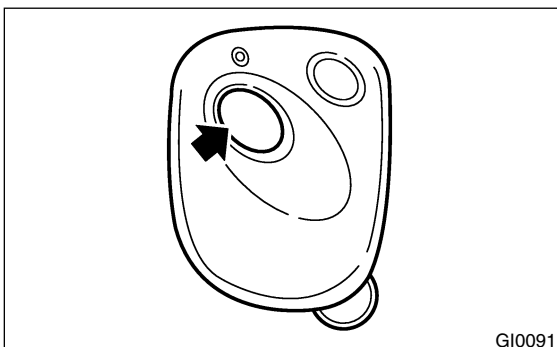

- Press the “UNLOCK/DISARM” button on the transmitter momentarily once and check if the driver’s door is unlocked, the horn chirps twice and the dome light illuminates.

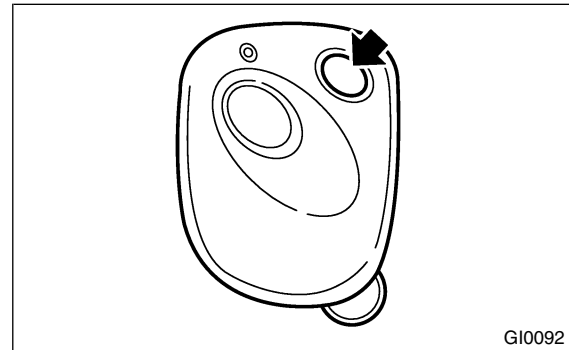

- Press the “UNLOCK/DISARM” button on the transmitter momentarily once again and check if all the doors including the rear gate on wagon are unlocked.
- Press the “LOCK/ARM” button on the transmitter a little bit of time (approx. 1.5 sec.) and check if a panicking condition occurs; the horn sounds continuously. Also, check if that condition lasts for 30 seconds or until any button of the transmitter is pressed.
- Press the “LOCK/ARM” button on the transmitter momentarily once with one of the doors including the rear gate (wagon) open and check if the horn chirps three times to warn of a door ajar. Then, bring all doors including the rear gate (wagon) in closed condition and check if all the doors are locked and the horn chirps once.
- Press the “LOCK” side of the power door locking switch with any one of the doors including the rear gate (wagon) open. Then, bring all the doors including the rear gate (wagon) in the closed condition and check if all the doors are locked and the horn chirps once.

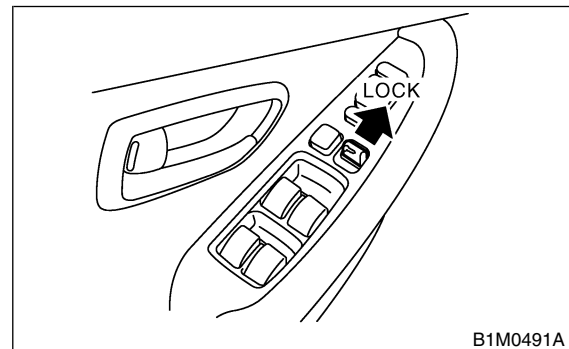



# PRE-DELIVERY INSPECTION

Pre-delivery Inspection

## 22. SECURITY SYSTEM SA09719G5022

Check the security system operations as follows.

- Open all the door windows fully.
- Remove the key from the ignition switch and close all the doors including rear gate (wagon).
- Press the “LOCK/ARM” button on the transmitter momentarily once and check if all the doors are locked, the horn chirps once, the parking lights flash once and the security indicator light flashes slowly to ensure that the security system has been brought into the arming state.

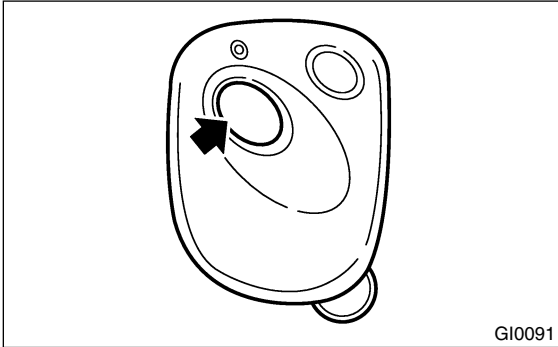

- Press the “UNLOCK/DISARM” button on the transmitter momentarily once and check if the driver’s door is unlocked, the horn chirps twice, the parking lights flash twice, the dome light illuminates and the security indicator light goes off to ensure that the system has been brought into the disarming state.

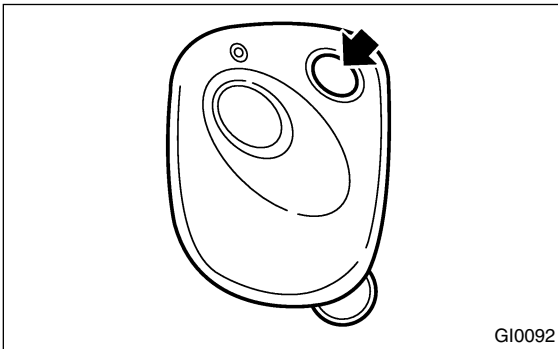

- Press the “UNLOCK/DISARM” button on the transmitter momentarily once again and check if all the doors including the rear gate on wagon are unlocked.
- Press the “LOCK/ARM” button on the transmitter a little bit of time (approx. 1.5 sec.) and check if a panicking condition occurs; the horn sounds continuously, the parking lights flash and the security indicator light flashes rapidly. Also, check if that condition lasts for 30 seconds or until any button of the transmitter is pressed.
- Press the “LOCK/ARM” button on the transmitter momentarily once with one of the doors including the rear gate (wagon) open and check if the horn chirps three times to warn of a door ajar.

Then, bring all doors including the rear gate (wagon) in closed condition and check if the arming condition is brought about; all the doors are locked, the horn chirps once and the parking lights flash once.

- Press the “LOCK” side of the power door locking switch with any one of the doors including the rear gate (wagon) open. Then, bring all the doors including the rear gate (wagon) in the closed condition and check if all the doors are locked, the horn chirps once and the parking lights flash once to ensure that the security system has been brought into the arming state.

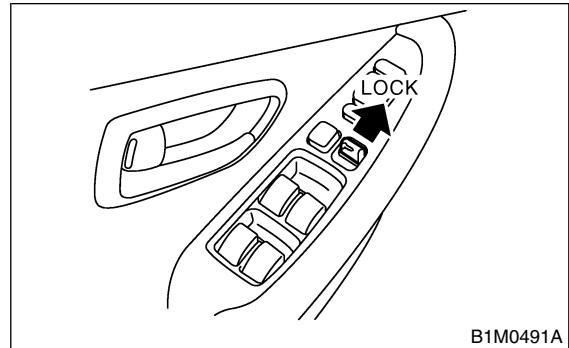

- Unlock a door using the inner lock knob or the key and open the door while the security system is in the arming state. Check to ensure that the alarming condition occurs, i.e. the horn sounds continuously, the parking lights flash and the security indicator light flashes rapidly, and that it lasts for 30 seconds or until the “UNLOCK/DISARM” button on the transmitter is pressed. Also, check to ensure that turning the ignition key to the “START” position in the arming state does not cause the starter motor to turn, thus the engine being prevented from starting.
- Apply a shock to the vehicle body with the security system in arming state, and check to ensure that the alarming condition occurs.
- Troubleshoot the security system if any one of the above-mentioned checks does not meet the requirements.

## 23. SEAT SA09719G5023

Check that each seat provides full functionality in sliding and reclining. Check all available functions of the rear seat such as a trunk-through center arm rest.

## 24. SEAT BELT SA09719G5024

Pull out the seat belt and then release it. Check that the belt webbing retracts smoothly.

## 25. WHEEL ALIGNMENT SA09719G5026

Check the wheel alignments. <Ref. to FS-6, Wheel Alignment.> and <Ref. to RS-8, Wheel Alignment.>

## 26. TEST MODE CONNECTOR SA09719G5027

Turn the ignition switch to ON and check that the check-engine light starts blinking. If the light blinks, return the ignition key to LOCK and disconnect the test mode connector. Then, turn the ignition key to ON again. If the check-engine light blinks at that time in spite of the disconnected test mode connector, carry out an engine diagnosis.

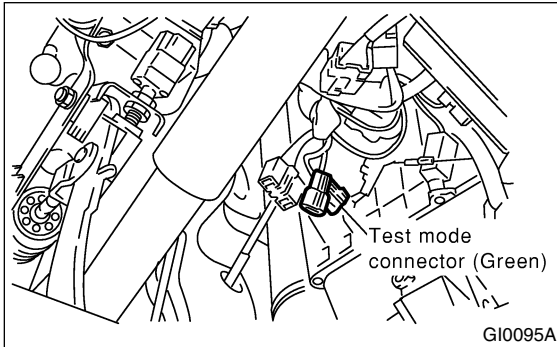

## 27. OPERATION CHECK OF SHIFT LOCK SYSTEM, KEY INTERLOCK, AND STARTER INTERLOCK SA09719G5028

- For an MT vehicle, check the starter interlock system operations.
- For an AT vehicle, check the shift lock and key interlock system operations.

## 28. STARTING CONDITION SA09719G5029

Start the engine and check that the engine starts smoothly. If any battery voltage problems are found, recharge or replace the battery. If any abnormal noises are observed, immediately stop the engine and check and repair the necessary components.

## 29. EXHAUST SYSTEM SA09719G5030

Listen to the exhaust noise to see if no abnormal noises are observed.

## 30. INDICATOR LIGHT SA09719G5031

Check that all the indicator lights are off.

## 31. CLOCK SA09719G5032

Check the clock for normal operations and enough accuracy.

## 32. RADIO SA09719G5033

Check the radio for full functionality and normal noise level. Also check the CD unit operations.

## 33. CIGARETTE LIGHTER SA09719G5034

Check that the cigarette lighter operations.

## 34. LIGHTING SYSTEM SA09719G5035

- Check the headlight operations.
- Check the brake light operations.
- Check the other lights for normal operations.

# PRE-DELIVERY INSPECTION

Pre-delivery Inspection

## 35. WINDOW WASHER SA09719G5036

- Before inspection of the window washer system, connect the washer connector to the washer motor.

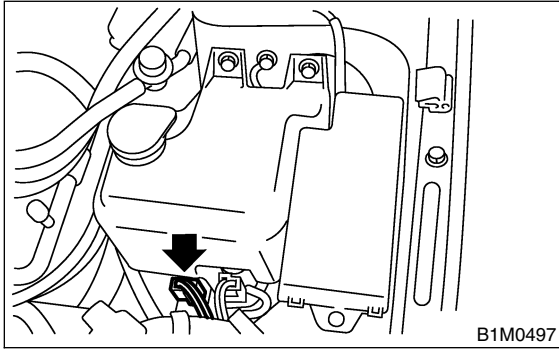

- Check that the window washer system injects washer fluid to the specified area of the windshield shown in the figure.

NOTE:

If the washer fluid does not cover the specified area, clean the nozzle.

**Front**

**Injection position:**

**A: 300 mm (11.81 in)**

**B: 100 mm (3.94 in)**

**C: 200 mm (7.87 in)**

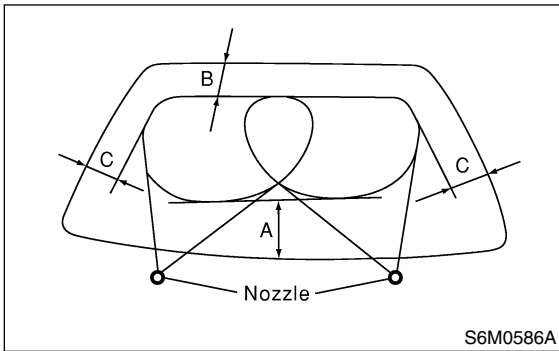

**Rear**

**Injection position:**

**A: 60 mm (2.36 in)**

**B: 42°**

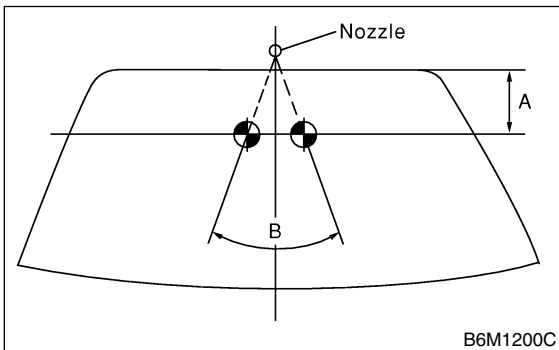

## 36. WIPER SA09719G5037

Check the front and rear wipers for normal operations.

## 37. POWER WINDOW OPERATION CHECK SA09719G5004

Manipulate the power window switches one by one to check that each of the power windows goes up and down with no abnormal noises.

## 38. BRAKE TEST SA09719G5038

Check the foot brake for normal operations.

## 39. PARKING BRAKE SA09719G5039

Check the parking brake for normal operations.

## 40. AT SHIFT CONTROL SA09719G5041

Set the AT select lever to each gear position while checking that the demanded gear position is correctly attained.

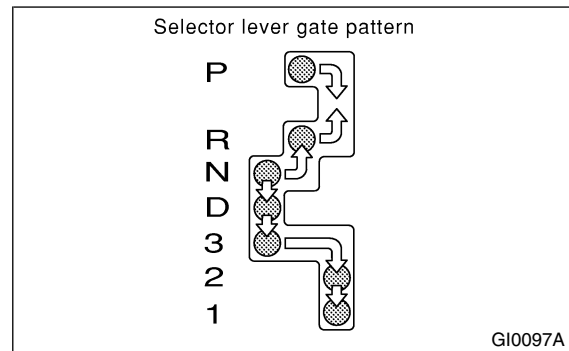

Selector Position	Gear Position			
	1st	2nd	3rd	4th
D	Yes	Yes	Yes	Yes
3	Yes	Yes	Yes	
2		Yes		
1	Yes			

## 41. HEATER & VENTILATION SA09719G5042

Operate the heater and ventilation system to check for normal airflow and heating capacity.

## 42. AIR CONDITIONER SA09719G5043

Operate the air conditioner. Check that the A/C compressor operates normally and enough cooling is provided.

## 43. CRUISE CONTROL SA09719G5044

Operate the cruise control system. Check that the system is activated and deactivated correctly.

## 44. ATF LEVEL SA09719G5045

Check that the ATF level is normal. If insufficient, check that no leaks are found. Then add the necessary amount of the specified ATF.

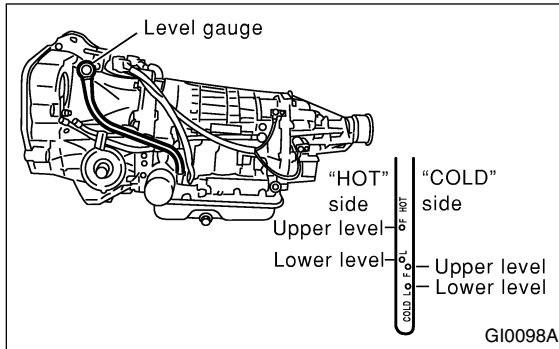

## 45. POWER STEERING FLUID LEVEL SA09719G5046

Check that the power steering fluid level is normal. If insufficient, check that no leaks are found. Then add the necessary amount of the specified power steering fluid.

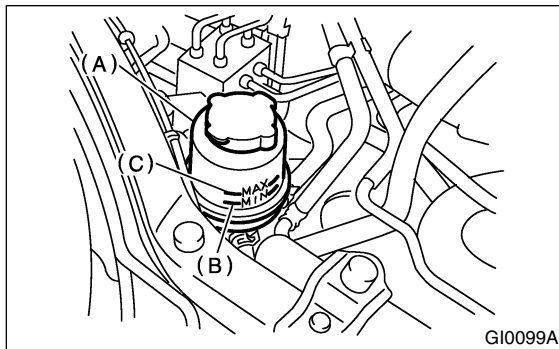

## 46. FLUID LEAK CHECK SA09719G5047

Check the entire areas of the vehicle for any trace of coolant/oil/fluid leaks.

## 47. WATER LEAK TEST SA09719G5048

Spray the vehicle with water and check that no water enters the passenger compartment.

- Before performing the water leakage test, remove anything that may obstruct the operation or which must be kept dry.
- Close all of the windows completely, and then close all of the doors tightly. Close the hood and trunk lid before starting the test.
- Connect a hose to a tap, and spray water on the vehicle. The rate of water discharge must be approx. 20 to 25 liters (5.3 to 6.6 US gal, 4.4 to 5.5 Imp gal) per minute.

When spraying water on areas adjacent to the floor and wheel house, increase the pressure. When directing water on areas other than the floor portion and wheel house, decrease the pressure. But the force of water must be made strong occasionally by pressing the end of the hose.

### NOTE:

Be sure to keep the hose at least 10 cm (3.9 in) from the vehicle.

- Check the following areas:
  - Front window and body framework mating portion
  - Door mating portions
  - Glass mating portions
  - Rear quarter window mating portions
  - Rear window and body framework mating portion
  - Around roof drips
- If any dampness in the compartments is discovered after the water has been applied, carefully check all areas that may have possibly contributed to the leak.

## 48. APPEARANCE CHECK 2 SA09719G5049

Check the vehicle body paints, plated faces, glass, and lenses for any dirt or damage.

# PRE-DELIVERY INSPECTION

Pre-delivery Inspection

---

**MEMO:**