

REAR ARM

Rear Suspension

4. Rear Arm S201105

A: REMOVAL S201105A18

- 1) Lift-up the vehicle and remove rear wheel.
- 2) Remove bearing unit.
<Ref. to DS-22, REMOVAL, Hub Unit Bearing.>
- 3) Remove bolt securing parking brake cable clamp to rear arm.

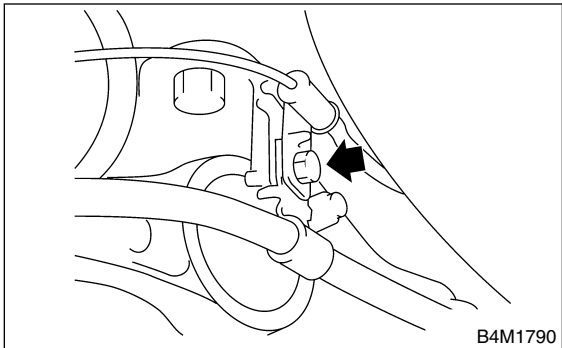

- 4) Remove bolt securing brake hose to rear arm.

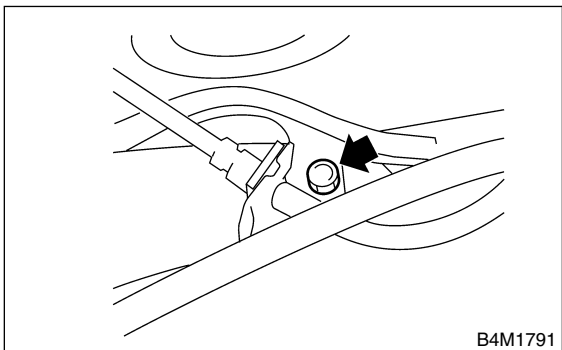

- 5) Remove bolt securing ABS sensor to rear arm.

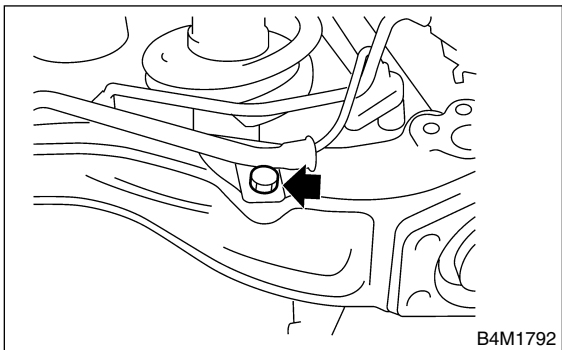

- 6) Suspend the back plate from sub frame.

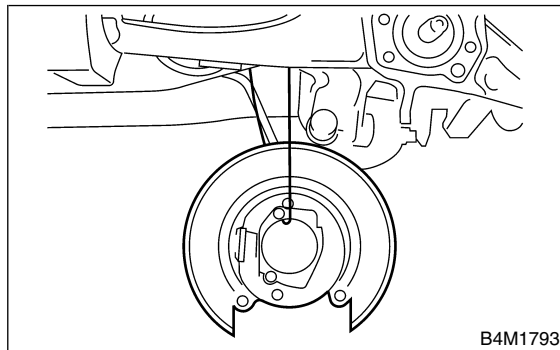

- 7) Remove nut securing stabilizer link to rear arm.

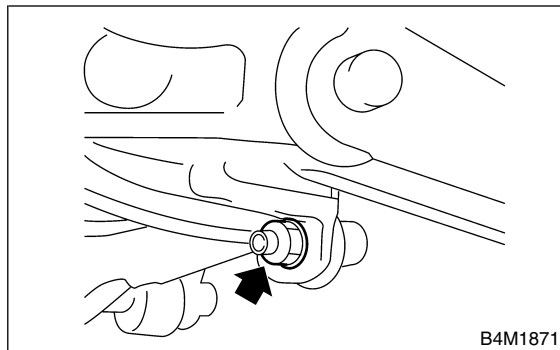

- 8) Remove bolt securing shock absorber to rear arm.

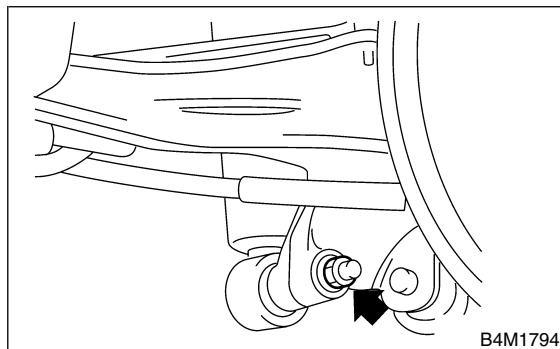

- 9) Use transmission jack to support rear arm horizontally.

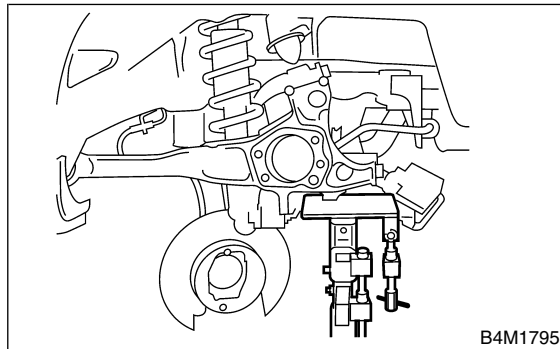

10) Remove bolt securing rear arm to body.

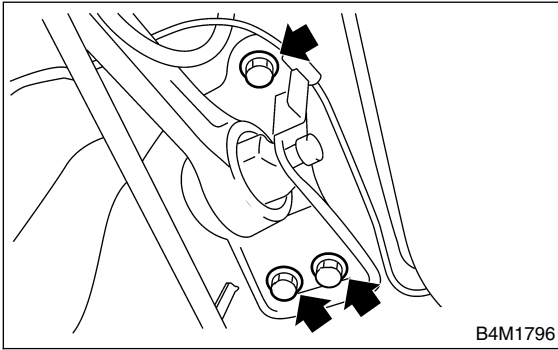

11) Loosen nut securing link front to rear arm.

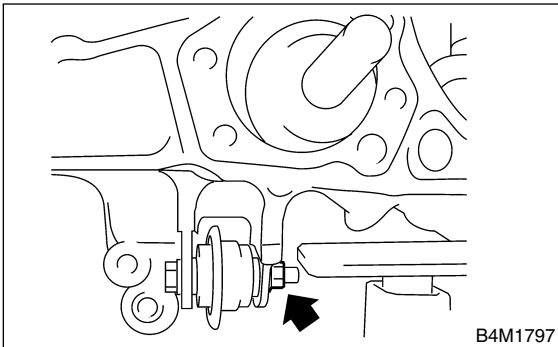

12) Loosen nut securing link rear to rear arm.

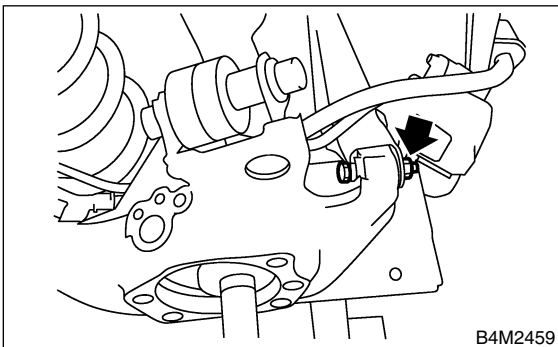

13) Loosen nut securing link upper to rear arm.

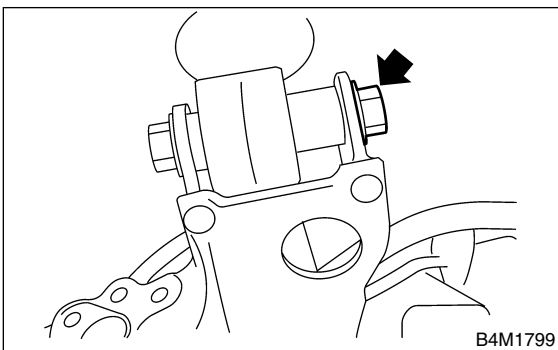

14) Remove bolts securing rear arm to links and remove rear arm.

B: INSTALLATION S201105A11

- 1) Use a transmission jack to support the rear arm.
- 2) Install rear arm and temporarily tighten bolts securing rear arm to links.
- 3) Install bearing unit.
<Ref. to DS-23, INSTALLATION, Hub Unit Bearing.>
- 4) Install bolt securing ABS sensor to rear arm.
- 5) Install bolt securing brake hose to rear arm.
- 6) Install bolt securing parking brake cable clamp to rear arm.
- 7) Place jack (furnished with vehicle) upside down and position it between link rear and sub frame. Adjust jack position so rear shock absorber is aligned with rear arm at their corresponding holes. Install lower shock absorber bolts.

CAUTION:
Put a cloth between jack and its mating area to protect link rear and sub frame from scratches.

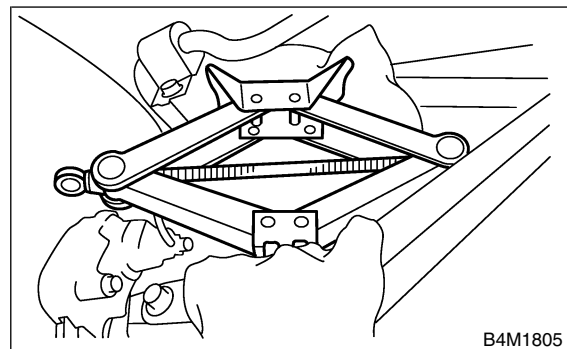

8) Using transmission jack, support rear arm horizontally and tighten nuts and bolts securing rear arm, link front, link rear, link upper and shock absorber.

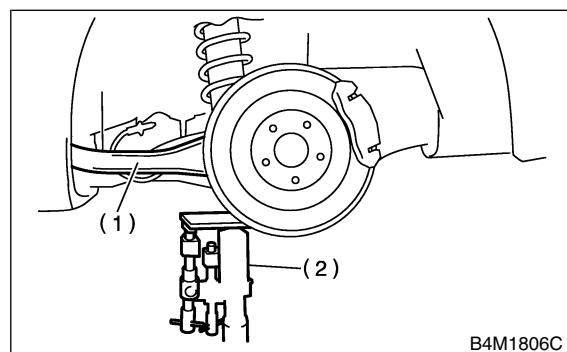

- (1) Rear arm
- (2) Transmission jack

REAR ARM

Rear Suspension

NOTE:

Check wheel alignment and adjust if necessary.

Tightening torque:

Refer to COMPONENT of General Description for tightening torque. <Ref. to RS-3, REAR SUSPENSION, COMPONENT, General Description.>

C: DISASSEMBLY S201105A06

1. FRONT BUSHING S201105A0601

1) Using ST-A, B, press front bushing out of place.
ST-A, B 20099AE020 INSTALLER & REMOVER SET

- (1) Set ST-A in position with larger inside diameter side facing up.
- (2) Set rear arm with protruded bushing side facing down.
- (3) Place ST-B on upper side of bushing, then press bushing out of position.

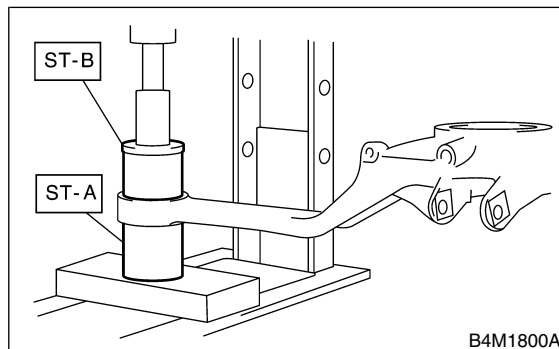

2. REAR BUSHING S201105A0602

Using ST-C and bearing puller, press rear bushing out of place.

ST-C 20099AE040 INSTALLER & REMOVER SET

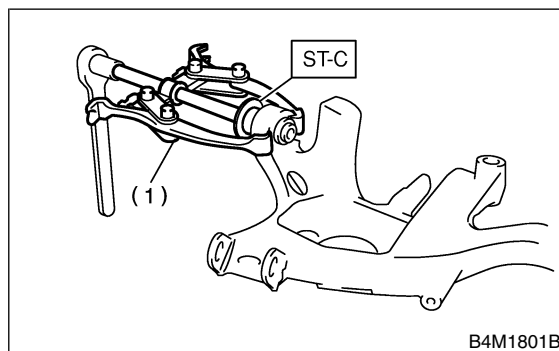

- (1) Bearing puller

D: ASSEMBLY S201105A02

1. FRONT BUSHING S201105A0201

1) Using ST-A, B, press bushing into trailing link.
 ST-A, B 20099AE020 INSTALLER &
 REMOVER SET

- (1) Set ST-A in position with smaller inside diameter side facing up.
- (2) Set rear arm in position with outer side of vehicle body facing down.
- (3) Place bushing on upper side of rear arm.
- (4) Place ST-B on upper side of bushing, then press bushing into position.

CAUTION:

- Install bushing with painted side facing up.
- Install front bushing in the proper direction, as shown in figure.

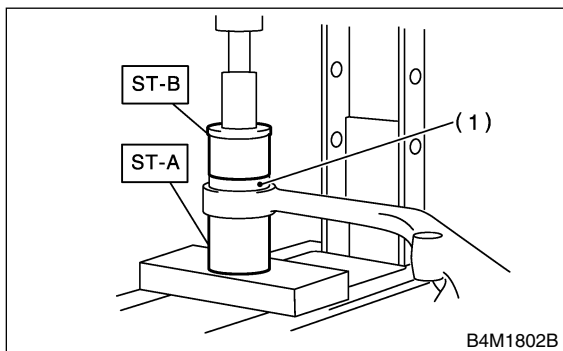
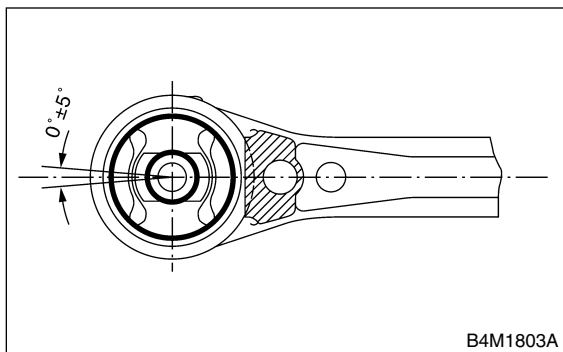

(1) Bushing

2. REAR BUSHING S201105A0202

1) Using ST-C, D and bearing puller, press bushing into trailing link.

ST-C, D 20099AE040 INSTALLER &
 REMOVER SET

- (1) Insert bushing into bore in ST-D.
- (2) Set ST-C, ST-D and bearing puller in position, as shown in the figure, and press bushing into position.

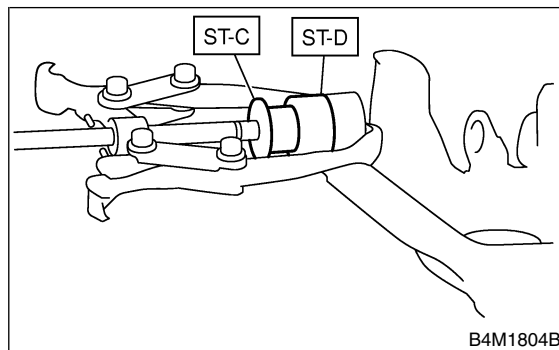

E: INSPECTION S201105A10

Check trailing links for bends, corrosion or damage.