

4. Release Bearing and Lever

S504251

A: REMOVAL S504251A18

- 1) Remove transmission assembly from vehicle body.
<Ref. to MT-27, REMOVAL, Manual Transmission Assembly.>
- 2) Remove the two clips from clutch release lever and remove release bearing.

NOTE:

Be careful not to deform clips.

- 3) Remove release lever seal.

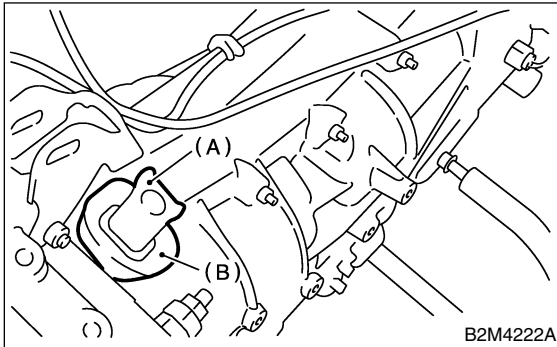

- (A) Clutch release lever
- (B) Release lever seal

- 4) Remove release lever retainer spring from release lever pivot with a screwdriver by accessing it through clutch housing release lever hole. Then remove release lever.

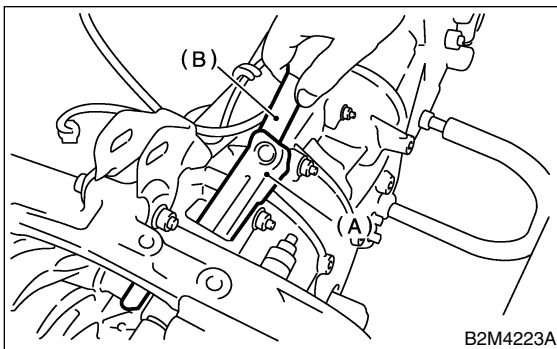

- (A) Clutch release lever
- (B) Screwdriver

- 5) Remove pivot.

B: INSTALLATION S504251A11

NOTE:

Before or during assembling, lubricate the following points with a light coat of grease.

- Contact surface of lever and pivot
- Contact surface of lever and bearing
- Transmission main shaft spline (Use grease containing molybdenum disulphide.)
- Contact surface of lever and operating cylinder

- 1) Install pivot.

Tightening torque:

T: 15.7 N·m (1.6 kgf·m, 11.6 ft·lb)

- 2) While pushing release lever to pivot and twisting it to both sides, fit retainer spring onto the constricted portion of pivot.

NOTE:

● Apply grease (SUNLIGHT 2: P/N 003602010) to contact point of release lever and operating cylinder. <Ref to CL-3, COMPONENT, General Description.>

- Confirm that retainer spring is securely fitted by observing it through the main case hole.

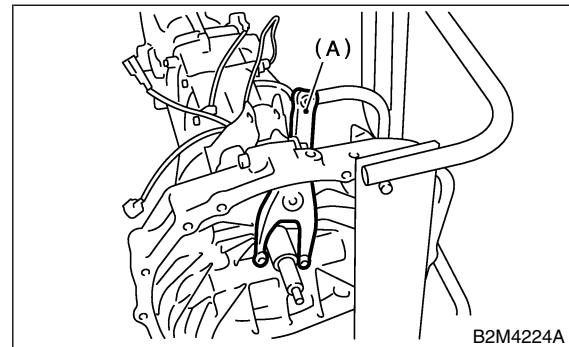

- (A) Release lever

- 3) Install release bearing and fasten it with two clips.

- 4) Install release lever seal.

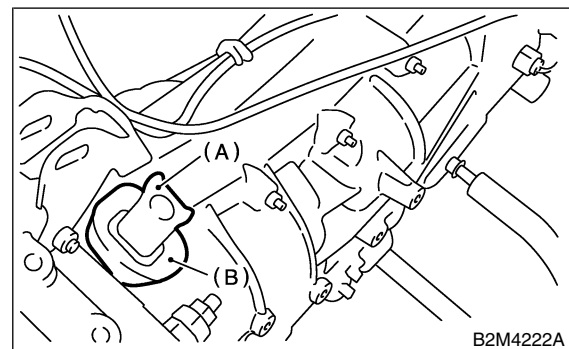

- (A) Clutch release lever
- (B) Screwdriver

RELEASE BEARING AND LEVER

Clutch System

5) Install transmission assembly.
<Ref. to MT-29, INSTALLATION, Manual Transmission Assembly.>

C: INSPECTION S504251A10

1. RELEASE BEARING S504251A1001

NOTE:

Since this bearing is grease sealed and is of a non-lubrication type, do not wash with gasoline or any solvent when servicing the clutch.

1) Check the bearing for smooth movement by applying force in the radial direction.

Radial direction stroke:

1.4 mm (0.055 in)

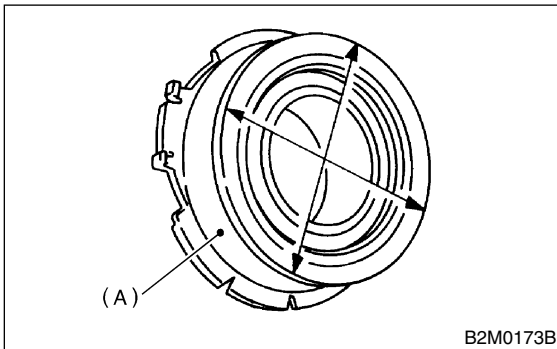

(A) Bearing case

2) Check the bearing for smooth rotation by applying pressure in the thrust direction.

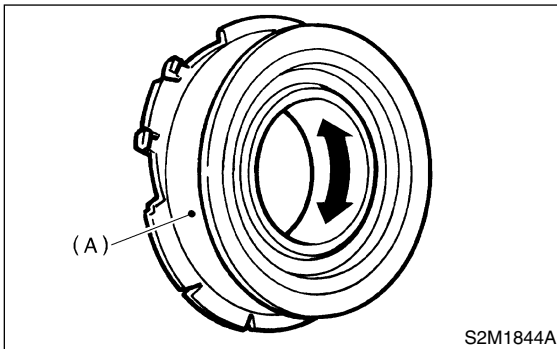

(A) Bearing case

3) Check wear and damage of bearing case surface contacting with lever.

2. RELEASE LEVER S504251A1002

1) Check lever pivot portion and the point of contact with release bearing case for wear.

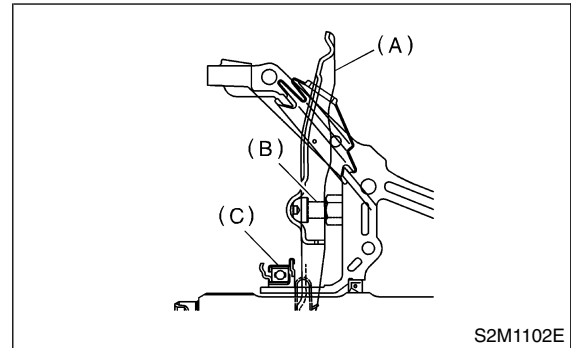

- (A) Clutch release lever
- (B) Pivot
- (C) Clutch release bearing