

# NOTE

***NT***



|              |           |
|--------------|-----------|
| 1. Note..... | Page<br>2 |
|--------------|-----------|



# NOTE

## NOTE

### 1. Note

#### A: NOTE

This is information that can improve efficiency of maintenance and assure sound work.

#### 1. FASTENER NOTICE

Fasteners are used to prevent parts from damage and dislocation due to looseness. Fasteners must be tightened to the specified torque.

Do not apply paint, lubricant, rust retardant, or other substances to the surface around bolts, fasteners, etc. Doing so will make it difficult to obtain the correct torque and result in looseness and other problems.

#### 2. STATIC ELECTRICITY DAMAGE

Do not touch the ECM, connectors, logic boards, and other such parts when there is a risk of static electricity. Always use a static electricity prevention cord or touch grounded metal before conducting work.

#### 3. IGNITION OFF BATTERY

When removing the battery cables, always be sure to turn the ignition off to prevent electrical damage to the ECM from rush current.

#### 4. SERVICE PARTS

Use authentic service parts for maximum performance and maintenance, when conducting repairs. Subaru/FHI will not be responsible for poor performance resulting from the use of parts not specified by a genuine dealer.

#### 5. LIFTS AND JACKS

When using a lift or jack-ridged rack to raise a vehicle, always follow instructions concerning jack-up points and weight limits to prevent the vehicle from falling, which could result in injury. Be especially careful to make sure the vehicle is balanced before raising it.

##### • Support locations

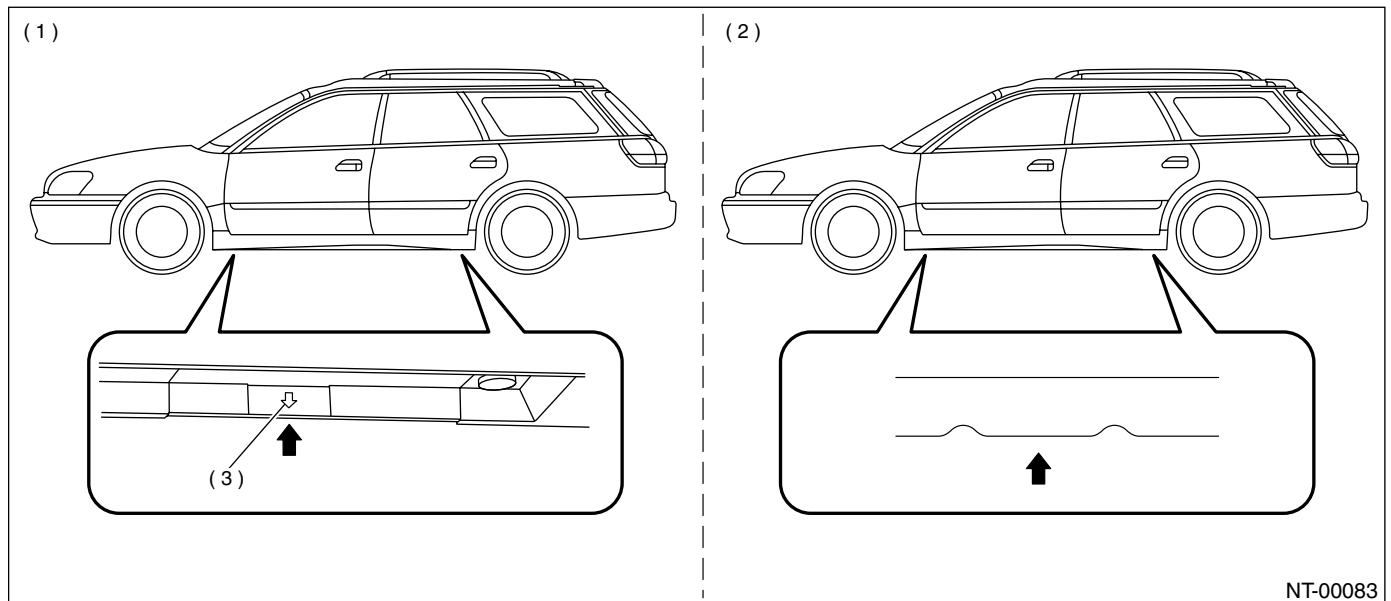

- (1) Model with side sill cover
- (2) Model without side sill cover
- (3) Jack-up point mark

• Pantograph jack

(1)

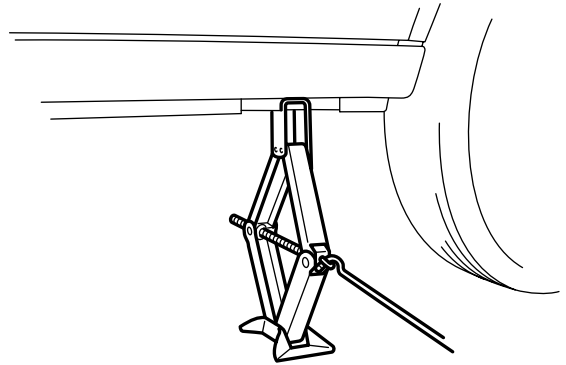
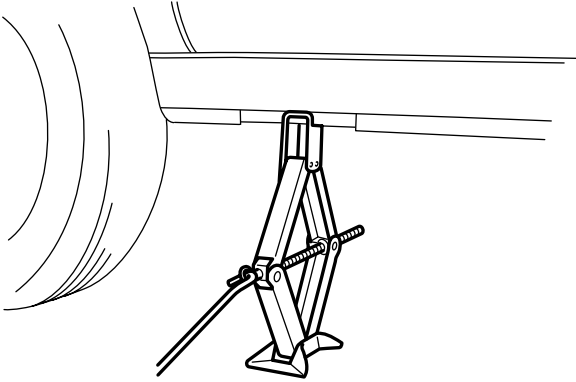

(2)

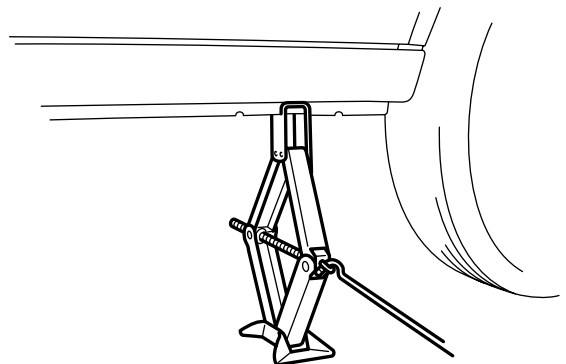
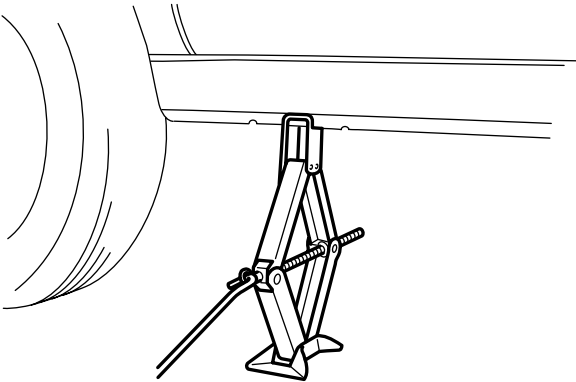

NT-00084

- (1) Model with side sill cover
- (2) Mode without side sill cover

# NOTE

## NOTE

### • Lift

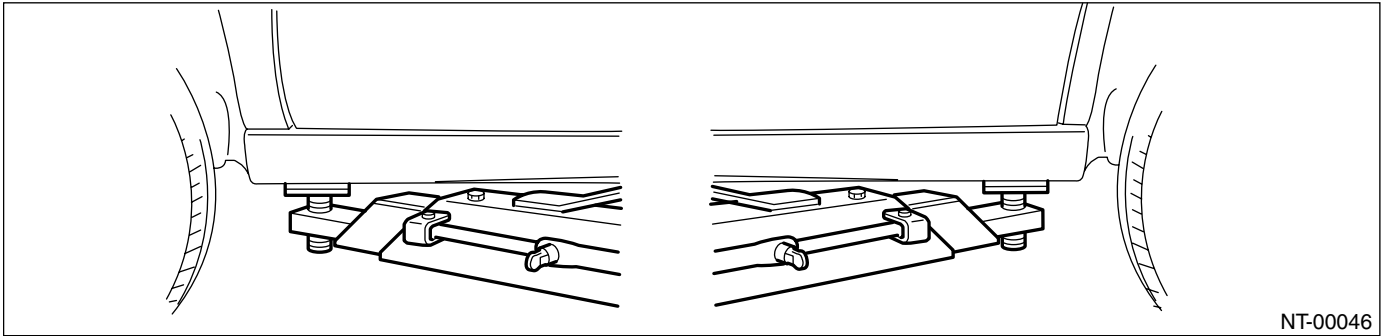

NT-00046

### • Safety stand

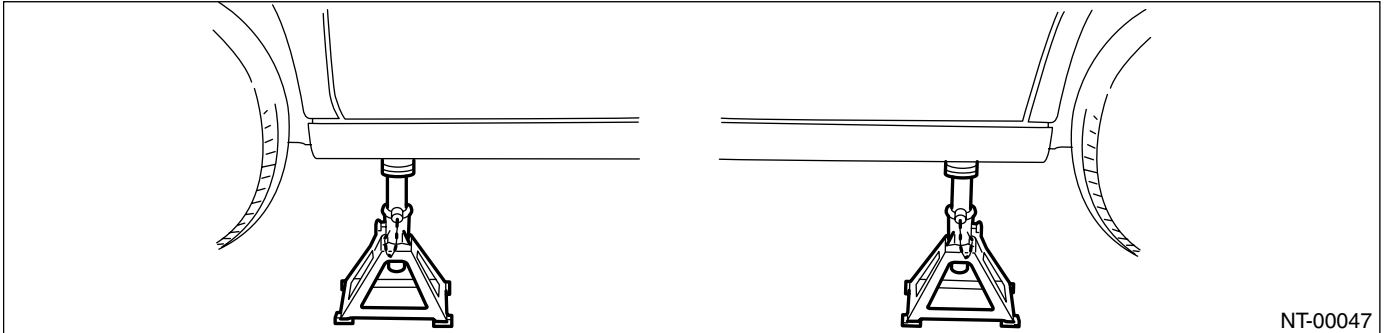

NT-00047

### Front

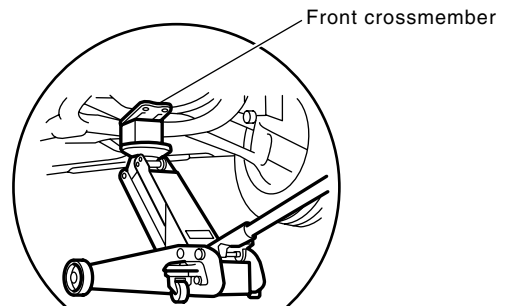
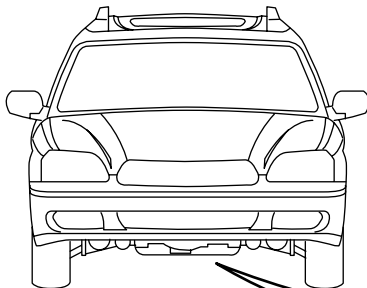

### Rear

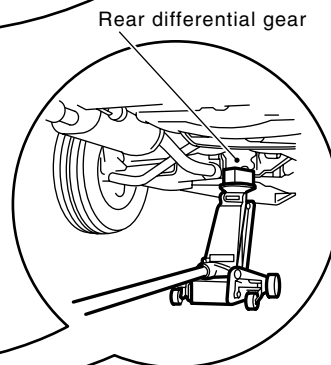
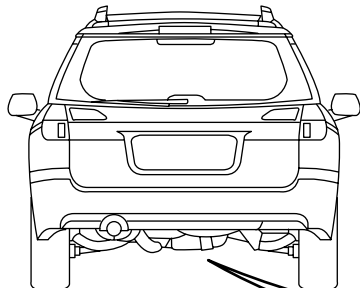

NT-00036

## 6. TIE DOWNS

Tie-downs are used when transporting vehicles and when using the chassis dynamo.

- **Tie-down points**

Attach tie-downs only to the specified points on the vehicle.

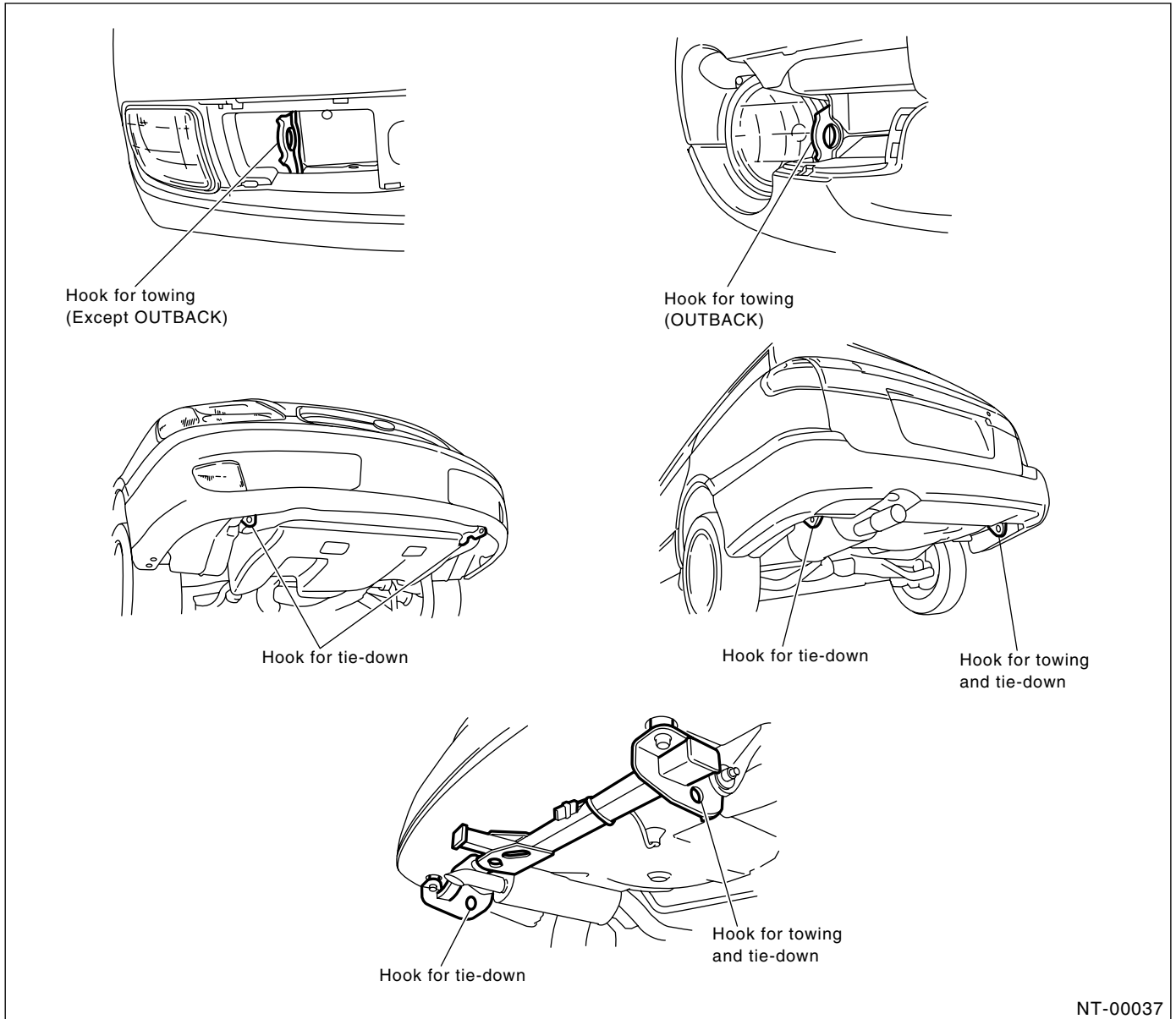

## NOTE

### • Chain direction at tie-down condition

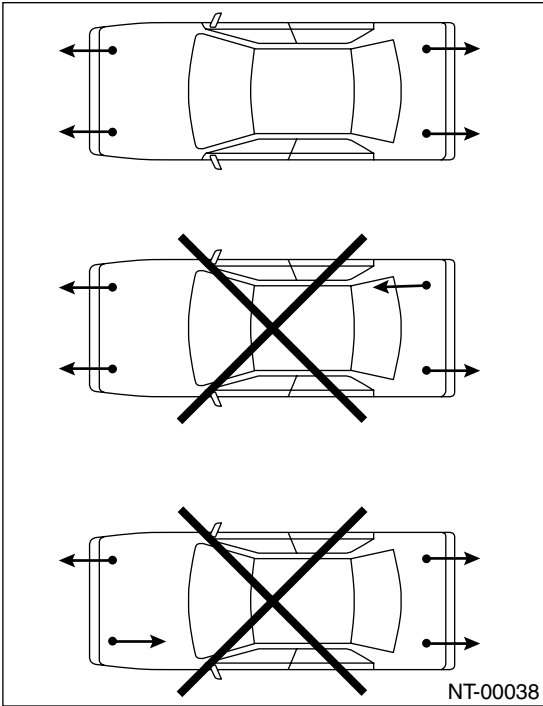

### • Chain pulling range at tie-down condition

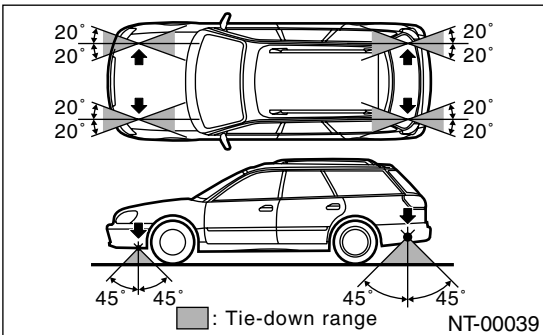

### • Vehicle sinking volume at tie-down condition

Measure distance L between tire highest point to arch highest point before tie-down and after tie-down. Difference of measurement value (drop height) shall be within 50.8 mm (2.00 in). Make sure to fix a vehicle securely.

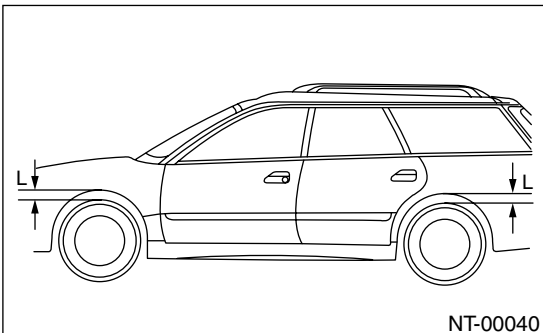

## 7. TOWING

Avoid towing vehicles except when the vehicle cannot be driven. For vehicles with AWD, AT or VTD, use a loader instead of towing. When towing other vehicles, to prevent excessive weight from damaging the hook or vehicle:

- Do not tow other vehicles with a front towing hook.
- Make sure the vehicle towing is heavier than the vehicle being towed.

## 8. FRONT HOOD STAY INSTALLATION

- At the check and general maintenance

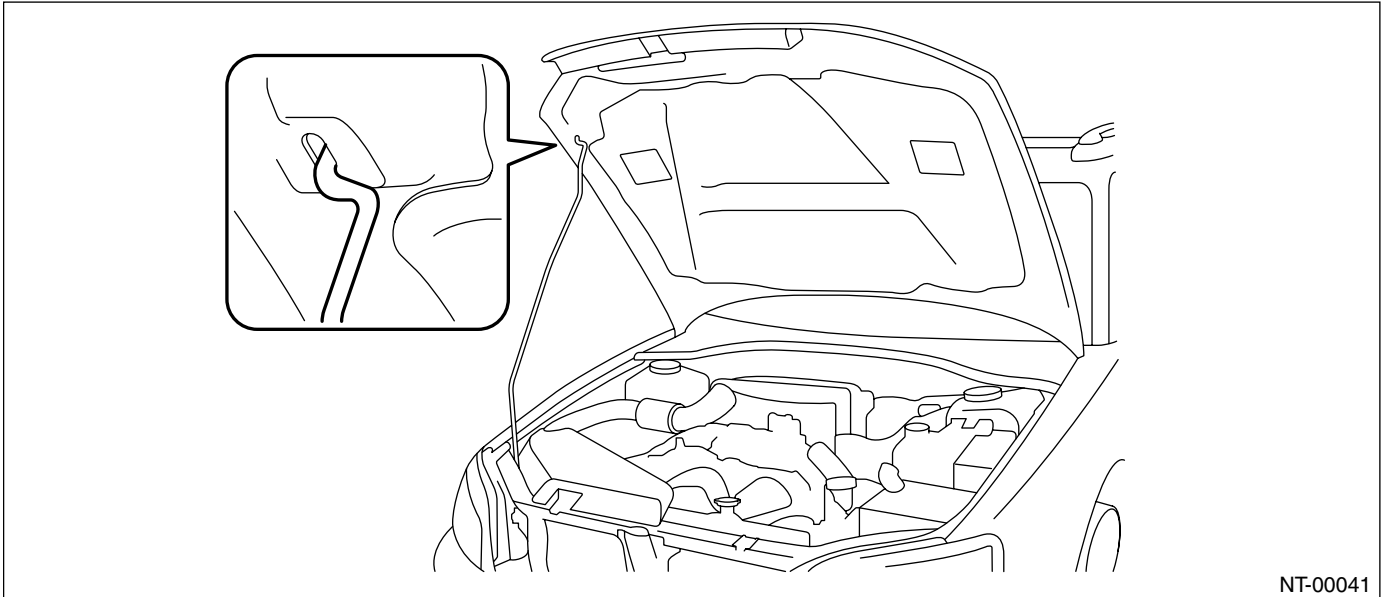

NT-00041

- When wider hood opening is necessary

Set stay into the hole of hood inner as shown in the figure below.

### NOTE:

Before setting the hood in this position, remove the windshield washer hose attaching clip from the hood.

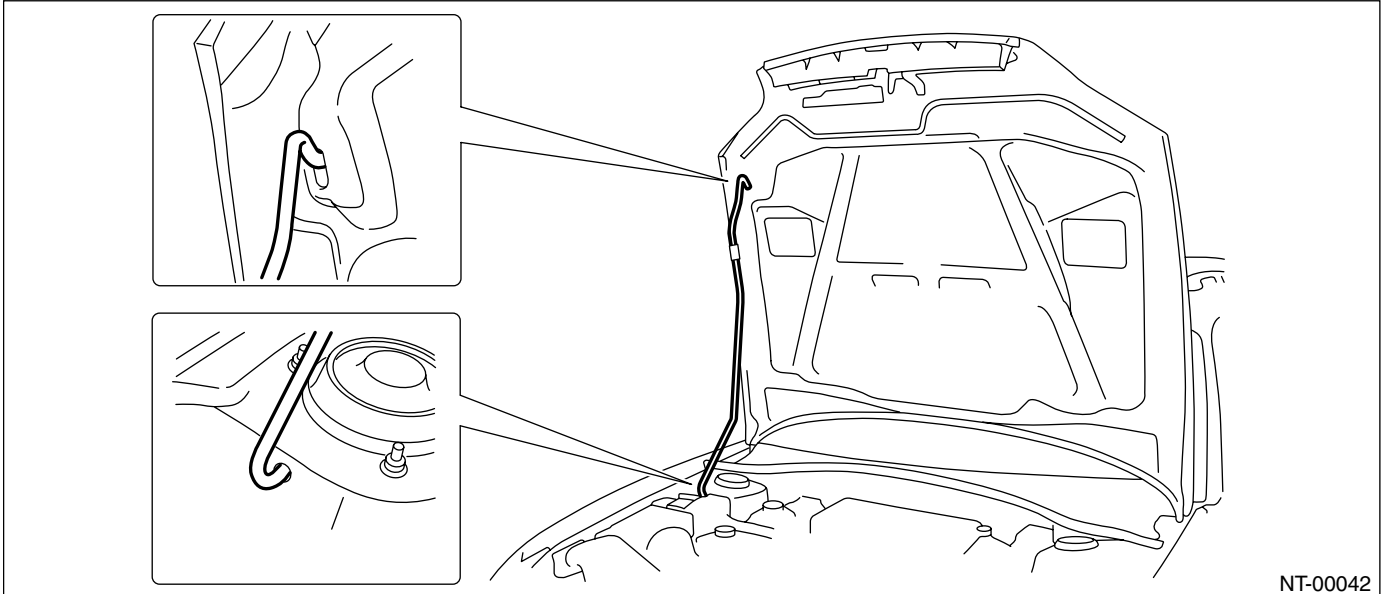

NT-00042

## 9. TRAINING

For information about training, contact a dealer or agent.

## 10. GENERAL SCAN TOOL

Using general scan tools will greatly improve efficiency of repairing engine electronic controls. The Subaru Select Monitor can be used to diagnose the engine and also the ABS, the air conditioner, and other parts.

# NOTE

NOTE

---

**MEMO:**