

GENERAL DESCRIPTION

GD(H4DOTC)

	Page
1. List of Diagnostic Trouble Code (DTC)	2
2. Diagnostic Trouble Code (DTC) Detecting Criteria	10



LIST OF DIAGNOSTIC TROUBLE CODE (DTC)

GENERAL DESCRIPTION

1. List of Diagnostic Trouble Code (DTC)

A: LIST

DTC	Item	Index
P0011	A Camshaft Position-Timing Over-Advanced or System Performance (Bank 1)	<Ref. to GD(H4DOTC)-10, DTC P0011 — “A” CAMSHAFT POSITION - TIMING OVER-ADVANCED OR SYSTEM PERFORMANCE (BANK 1) —, Diagnostic Trouble Code (DTC) Detecting Criteria.>
P0021	A Camshaft Position-Timing Over-Advanced or System Performance (Bank 2)	<Ref. to GD(H4DOTC)-13, DTC P0021 — “A” CAMSHAFT POSITION - TIMING OVER-ADVANCED OR SYSTEM PERFORMANCE (BANK 2) —, Diagnostic Trouble Code (DTC) Detecting Criteria.>
P0030	HO2S Heater Control Circuit (Bank 1 Sensor 1)	<Ref. to GD(H4DOTC)-14, DTC P0030 — HO2S HEATER CONTROL CIRCUIT (BANK 1 SENSOR 1) —, Diagnostic Trouble Code (DTC) Detecting Criteria.>
P0031	HO2S Heater Control Circuit Low (Bank 1 Sensor 1)	<Ref. to GD(H4DOTC)-16, DTC P0031 — HO2S HEATER CONTROL CIRCUIT LOW (BANK 1 SENSOR 1) —, Diagnostic Trouble Code (DTC) Detecting Criteria.>
P0032	HO2S Heater Control Circuit High (Bank 1 Sensor 1)	<Ref. to GD(H4DOTC)-18, DTC P0032 — HO2S HEATER CONTROL CIRCUIT HIGH (BANK 1 SENSOR 1) —, Diagnostic Trouble Code (DTC) Detecting Criteria.>
P0037	HO2S Heater Control Circuit Low (Bank 1 Sensor 2)	<Ref. to GD(H4DOTC)-20, DTC P0037 — HO2S HEATER CONTROL CIRCUIT LOW (BANK 1 SENSOR 2) —, Diagnostic Trouble Code (DTC) Detecting Criteria.>
P0038	HO2S Heater Control Circuit High (Bank 1 Sensor 2)	<Ref. to GD(H4DOTC)-22, DTC P0038 — HO2S HEATER CONTROL CIRCUIT HIGH (BANK 1 SENSOR 2) —, Diagnostic Trouble Code (DTC) Detecting Criteria.>
P0068	Manifold Absolute Pressure/Barometric Pressure Circuit Range/Performance	<Ref. to GD(H4DOTC)-24, DTC P0068 — MANIFOLD PRESSURE SENSOR RANGE/PERFORMANCE —, Diagnostic Trouble Code (DTC) Detecting Criteria.>
P0101	Mass or Volume Air Flow Circuit Range/Performance	<Ref. to GD(H4DOTC)-26, DTC P0101 — MASS OR VOLUME AIR FLOW CIRCUIT RANGE/PERFORMANCE —, Diagnostic Trouble Code (DTC) Detecting Criteria.>
P0102	Mass or Volume Air Flow Circuit Low Input	<Ref. to GD(H4DOTC)-30, DTC P0102 — MASS OR VOLUME AIR FLOW CIRCUIT LOW INPUT —, Diagnostic Trouble Code (DTC) Detecting Criteria.>
P0103	Mass or Volume Air Flow Circuit High Input	<Ref. to GD(H4DOTC)-32, DTC P0103 — MASS OR VOLUME AIR FLOW CIRCUIT HIGH INPUT —, Diagnostic Trouble Code (DTC) Detecting Criteria.>
P0107	Manifold Absolute Pressure/Barometric Pressure Circuit Low Input	<Ref. to GD(H4DOTC)-34, DTC P0107 — MANIFOLD ABSOLUTE PRESSURE/BAROMETRIC PRESSURE CIRCUIT LOW INPUT —, Diagnostic Trouble Code (DTC) Detecting Criteria.>
P0108	Manifold Absolute Pressure/Barometric Pressure Circuit High Input	<Ref. to GD(H4DOTC)-36, DTC P0108 — MANIFOLD ABSOLUTE PRESSURE/BAROMETRIC PRESSURE CIRCUIT HIGH INPUT —, Diagnostic Trouble Code (DTC) Detecting Criteria.>
P0111	Intake Air Temperature Circuit Range/Performance	<Ref. to GD(H4DOTC)-38, DTC P0111 — INTAKE AIR TEMPERATURE CIRCUIT RANGE/PERFORMANCE —, Diagnostic Trouble Code (DTC) Detecting Criteria.>
P0112	Intake Air Temperature Circuit Low Input	<Ref. to GD(H4DOTC)-40, DTC P0112 — INTAKE AIR TEMPERATURE CIRCUIT LOW INPUT —, Diagnostic Trouble Code (DTC) Detecting Criteria.>
P0113	Intake Air Temperature Circuit High Input	<Ref. to GD(H4DOTC)-42, DTC P0113 — INTAKE AIR TEMPERATURE CIRCUIT HIGH INPUT —, Diagnostic Trouble Code (DTC) Detecting Criteria.>
P0117	Engine Coolant Temperature Circuit Low Input	<Ref. to GD(H4DOTC)-44, DTC P0117 — ENGINE COOLANT TEMPERATURE CIRCUIT LOW INPUT —, Diagnostic Trouble Code (DTC) Detecting Criteria.>
P0118	Engine Coolant Temperature Circuit High Input	<Ref. to GD(H4DOTC)-46, DTC P0118 — ENGINE COOLANT TEMPERATURE CIRCUIT HIGH INPUT —, Diagnostic Trouble Code (DTC) Detecting Criteria.>

LIST OF DIAGNOSTIC TROUBLE CODE (DTC)

GENERAL DESCRIPTION

DTC	Item	Index
P0122	Throttle/Pedal Position Sensor/ Switch "A" Circuit Low Input	<Ref. to GD(H4DOTC)-48, DTC P0122 — THROTTLE/PEDAL POSITION SENSOR/SWITCH "A" CIRCUIT LOW INPUT —, Diagnostic Trouble Code (DTC) Detecting Criteria.>
P0123	Throttle/Pedal Position Sensor/ Switch "A" Circuit High Input	<Ref. to GD(H4DOTC)-50, DTC P0123 — THROTTLE/PEDAL POSITION SENSOR/SWITCH "A" CIRCUIT HIGH INPUT —, Diagnostic Trouble Code (DTC) Detecting Criteria.>
P0125	Insufficient Coolant Temperature for Closed Loop Fuel Control	<Ref. to GD(H4DOTC)-52, DTC P0125 — INSUFFICIENT COOLANT TEMPERATURE FOR CLOSED LOOP FUEL CONTROL —, Diagnostic Trouble Code (DTC) Detecting Criteria.>
P0128	Coolant Thermostat (Coolant Temperature Below Thermostat Regulating Temperature)	<Ref. to GD(H4DOTC)-56, DTC P0128 — COOLANT THERMOSTAT (COOLANT TEMPERATURE BELOW THERMOSTAT REGULATING TEMPERATURE) —, Diagnostic Trouble Code (DTC) Detecting Criteria.>
P0129	Atmospheric Pressure Sensor Circuit Range/Performance	<Ref. to GD(H4DOTC)-58, DTC P0129 — BAROMETRIC PRESSURE TOO LOW —, Diagnostic Trouble Code (DTC) Detecting Criteria.>
P0131	O ₂ Sensor Circuit Low Voltage (Bank 1 Sensor 1)	<Ref. to GD(H4DOTC)-60, DTC P0131 — O ₂ SENSOR CIRCUIT LOW VOLTAGE (BANK 1 SENSOR 1) —, Diagnostic Trouble Code (DTC) Detecting Criteria.>
P0132	O ₂ Sensor Circuit High Voltage (Bank 1 Sensor 1)	<Ref. to GD(H4DOTC)-62, DTC P0132 — O ₂ SENSOR CIRCUIT HIGH VOLTAGE (BANK 1 SENSOR 1) —, Diagnostic Trouble Code (DTC) Detecting Criteria.>
P0133	O ₂ Sensor Circuit Slow Response (Bank 1 Sensor 1)	<Ref. to GD(H4DOTC)-64, DTC P0133 — O ₂ SENSOR CIRCUIT SLOW RESPONSE (BANK 1 SENSOR 1) —, Diagnostic Trouble Code (DTC) Detecting Criteria.>
P0134	O ₂ Sensor Circuit No Activity Detected (Bank 1 Sensor 1)	<Ref. to GD(H4DOTC)-68, DTC P0134 — O ₂ SENSOR CIRCUIT NO ACTIVITY DETECTED (BANK 1 SENSOR 1) —, Diagnostic Trouble Code (DTC) Detecting Criteria.>
P0137	O ₂ Sensor Circuit Low Voltage (Bank 1 Sensor 2)	<Ref. to GD(H4DOTC)-70, DTC P0137 — O ₂ SENSOR CIRCUIT LOW VOLTAGE (BANK 1 SENSOR 2) —, Diagnostic Trouble Code (DTC) Detecting Criteria.>
P0138	O ₂ Sensor Circuit High Voltage (Bank 1 Sensor 2)	<Ref. to GD(H4DOTC)-72, DTC P0138 — O ₂ SENSOR CIRCUIT HIGH VOLTAGE (BANK 1 SENSOR 2) —, Diagnostic Trouble Code (DTC) Detecting Criteria.>
P0139	O ₂ Sensor Circuit Slow Response (Bank 1 Sensor 2)	<Ref. to GD(H4DOTC)-74, DTC P0139 — O ₂ SENSOR CIRCUIT SLOW RESPONSE (BANK 1 SENSOR 2) —, Diagnostic Trouble Code (DTC) Detecting Criteria.>
P0171	System too Lean (Bank 1)	<Ref. to GD(H4DOTC)-78, DTC P0171 — SYSTEM TOO LEAN (BANK 1) —, Diagnostic Trouble Code (DTC) Detecting Criteria.>
P0172	System too Rich (Bank 1)	<Ref. to GD(H4DOTC)-82, DTC P0172 — SYSTEM TOO RICH (BANK 1) —, Diagnostic Trouble Code (DTC) Detecting Criteria.>
P0181	Fuel Temperature Sensor "A" Circuit Range/Performance	<Ref. to GD(H4DOTC)-85, DTC P0181 — FUEL TEMPERATURE SENSOR "A" CIRCUIT RANGE/PERFORMANCE —, Diagnostic Trouble Code (DTC) Detecting Criteria.>
P0182	Fuel Temperature Sensor "A" Circuit Low Input	<Ref. to GD(H4DOTC)-88, DTC P0182 — FUEL TEMPERATURE SENSOR "A" CIRCUIT LOW INPUT —, Diagnostic Trouble Code (DTC) Detecting Criteria.>
P0183	Fuel Temperature Sensor "A" Circuit High Input	<Ref. to GD(H4DOTC)-90, DTC P0183 — FUEL TEMPERATURE SENSOR "A" CIRCUIT HIGH INPUT —, Diagnostic Trouble Code (DTC) Detecting Criteria.>
P0222	Throttle/Pedal Position Sensor/ Switch "B" Circuit Low Input	<Ref. to GD(H4DOTC)-92, DTC P0222 — THROTTLE/PEDAL POSITION SENSOR/SWITCH "B" CIRCUIT LOW INPUT —, Diagnostic Trouble Code (DTC) Detecting Criteria.>
P0223	Throttle/Pedal Position Sensor/ Switch "B" Circuit High Input	<Ref. to GD(H4DOTC)-94, DTC P0223 — THROTTLE/PEDAL POSITION SENSOR/SWITCH "B" CIRCUIT HIGH INPUT —, Diagnostic Trouble Code (DTC) Detecting Criteria.>
P0230	Fuel Pump Primary Circuit	<Ref. to GD(H4DOTC)-96, DTC P0230 — FUEL PUMP PRIMARY CIRCUIT —, Diagnostic Trouble Code (DTC) Detecting Criteria.>

LIST OF DIAGNOSTIC TROUBLE CODE (DTC)

GENERAL DESCRIPTION

DTC	Item	Index
P0244	Turbo/Super Charger Wastegate Solenoid "A" Range/Performance	<Ref. to GD(H4DOTC)-98, DTC P0244 — TURBO/SUPER CHARGER WASTEGATE SOLENOID "A" RANGE/PERFORMANCE —, Diagnostic Trouble Code (DTC) Detecting Criteria.>
P0245	Turbo/Super Charger Wastegate Solenoid "A" Low	<Ref. to GD(H4DOTC)-100, DTC P0245 — TURBO/SUPER CHARGER WASTEGATE SOLENOID "A" LOW —, Diagnostic Trouble Code (DTC) Detecting Criteria.>
P0246	Turbo/Super Charger Wastegate Solenoid "A" High	<Ref. to GD(H4DOTC)-102, DTC P0246 — TURBO/SUPER CHARGER WASTEGATE SOLENOID "A" HIGH —, Diagnostic Trouble Code (DTC) Detecting Criteria.>
P0301	Cylinder 1 misfire detected	<Ref. to GD(H4DOTC)-104, DTC P0301 — CYLINDER 1 MISFIRE DETECTED —, Diagnostic Trouble Code (DTC) Detecting Criteria.>
P0302	Cylinder 2 misfire detected	<Ref. to GD(H4DOTC)-110, DTC P0302 — CYLINDER 2 MISFIRE DETECTED —, Diagnostic Trouble Code (DTC) Detecting Criteria.>
P0303	Cylinder 3 misfire detected	<Ref. to GD(H4DOTC)-110, DTC P0303 — CYLINDER 3 MISFIRE DETECTED —, Diagnostic Trouble Code (DTC) Detecting Criteria.>
P0304	Cylinder 4 misfire detected	<Ref. to GD(H4DOTC)-110, DTC P0304 — CYLINDER 4 MISFIRE DETECTED —, Diagnostic Trouble Code (DTC) Detecting Criteria.>
P0327	Knock Sensor 1 Circuit Low Input (Bank 1 or Single Sensor)	<Ref. to GD(H4DOTC)-112, DTC P0327 — KNOCK SENSOR 1 CIRCUIT LOW INPUT (BANK 1 OR SINGLE SENSOR) —, Diagnostic Trouble Code (DTC) Detecting Criteria.>
P0328	Knock Sensor 1 Circuit High Input (Bank 1 or Single Sensor)	<Ref. to GD(H4DOTC)-114, DTC P0328 — KNOCK SENSOR 1 CIRCUIT HIGH INPUT (BANK 1 OR SINGLE SENSOR) —, Diagnostic Trouble Code (DTC) Detecting Criteria.>
P0335	Crankshaft Position Sensor "A" Circuit	<Ref. to GD(H4DOTC)-116, DTC P0335 — CRANKSHAFT POSITION SENSOR "A" CIRCUIT —, Diagnostic Trouble Code (DTC) Detecting Criteria.>
P0336	Crankshaft Position Sensor "A" Circuit Range/Performance	<Ref. to GD(H4DOTC)-118, DTC P0336 — CRANKSHAFT POSITION SENSOR "A" CIRCUIT RANGE/PERFORMANCE —, Diagnostic Trouble Code (DTC) Detecting Criteria.>
P0340	Camshaft Position Sensor "A" Circuit (Bank 1 or Single Sensor)	<Ref. to GD(H4DOTC)-120, DTC P0340 — CAMSHAFT POSITION SENSOR "A" CIRCUIT (BANK 1 OR SINGLE SENSOR) —, Diagnostic Trouble Code (DTC) Detecting Criteria.>
P0345	Camshaft Position Sensor "A" Circuit (Bank 2)	<Ref. to GD(H4DOTC)-122, DTC P0345 — CAMSHAFT POSITION SENSOR "A" CIRCUIT (BANK 2) —, Diagnostic Trouble Code (DTC) Detecting Criteria.>
P0420	Catalyst System Efficiency Below Threshold (Bank 1)	<Ref. to GD(H4DOTC)-124, DTC P0420 — CATALYST SYSTEM EFFICIENCY BELOW THRESHOLD (BANK 1) —, Diagnostic Trouble Code (DTC) Detecting Criteria.>
P0442	Evaporative Emission Control System Leak Detected (small leak)	<Ref. to GD(H4DOTC)-128, DTC P0442 — EVAPORATIVE EMISSION CONTROL SYSTEM LEAK DETECTED (SMALL LEAK) —, Diagnostic Trouble Code (DTC) Detecting Criteria.>
P0447	Evaporative Emission Control System Vent Control Circuit Open	<Ref. to GD(H4DOTC)-152, DTC P0447 — EVAPORATIVE EMISSION CONTROL SYSTEM VENT CONTROL CIRCUIT OPEN —, Diagnostic Trouble Code (DTC) Detecting Criteria.>
P0448	Evaporative Emission Control System Vent Control Circuit Shorted	<Ref. to GD(H4DOTC)-154, DTC P0448 — EVAPORATIVE EMISSION CONTROL SYSTEM VENT CONTROL CIRCUIT SHORTED —, Diagnostic Trouble Code (DTC) Detecting Criteria.>
P0451	Evaporative Emission Control System Pressure Sensor Range/Performance	<Ref. to GD(H4DOTC)-156, DTC P0451 — EVAPORATIVE EMISSION CONTROL SYSTEM PRESSURE SENSOR RANGE/PERFORMANCE —, Diagnostic Trouble Code (DTC) Detecting Criteria.>
P0452	Evaporative Emission Control System Pressure Sensor Low Input	<Ref. to GD(H4DOTC)-158, DTC P0452 — EVAPORATIVE EMISSION CONTROL SYSTEM PRESSURE SENSOR LOW INPUT —, Diagnostic Trouble Code (DTC) Detecting Criteria.>
P0453	Evaporative Emission Control System Pressure Sensor High Input	<Ref. to GD(H4DOTC)-160, DTC P0453 — EVAPORATIVE EMISSION CONTROL SYSTEM PRESSURE SENSOR HIGH INPUT —, Diagnostic Trouble Code (DTC) Detecting Criteria.>

LIST OF DIAGNOSTIC TROUBLE CODE (DTC)

GENERAL DESCRIPTION

DTC	Item	Index
P0456	Evaporative Emission Control System Leak Detected (very small leak)	<Ref. to GD(H4DOTC)-162, DTC P0456 — EVAPORATIVE EMISSION CONTROL SYSTEM LEAK DETECTED (VERY SMALL LEAK) —, Diagnostic Trouble Code (DTC) Detecting Criteria.>
P0457	Evaporative Emission Control System Leak Detected (fuel cap loose/off)	<Ref. to GD(H4DOTC)-162, DTC P0457 — EVAPORATIVE EMISSION CONTROL SYSTEM LEAK DETECTED (FUEL CAP LOOSE/OFF) —, Diagnostic Trouble Code (DTC) Detecting Criteria.>
P0458	Evaporative Emission Control System Purge Control Valve Circuit Low	<Ref. to GD(H4DOTC)-164, DTC P0458 — EVAPORATIVE EMISSION CONTROL SYSTEM PURGE CONTROL VALVE CIRCUIT LOW —, Diagnostic Trouble Code (DTC) Detecting Criteria.>
P0459	Evaporative Emission Control System Purge Control Valve Circuit High	<Ref. to GD(H4DOTC)-166, DTC P0459 — EVAPORATIVE EMISSION CONTROL SYSTEM PURGE CONTROL VALVE CIRCUIT HIGH —, Diagnostic Trouble Code (DTC) Detecting Criteria.>
P0461	Fuel Level Sensor Circuit Range/Performance	<Ref. to GD(H4DOTC)-168, DTC P0461 — FUEL LEVEL SENSOR CIRCUIT RANGE/PERFORMANCE —, Diagnostic Trouble Code (DTC) Detecting Criteria.>
P0462	Fuel Level Sensor Circuit Low Input	<Ref. to GD(H4DOTC)-170, DTC P0462 — FUEL LEVEL SENSOR CIRCUIT LOW INPUT —, Diagnostic Trouble Code (DTC) Detecting Criteria.>
P0463	Fuel Level Sensor Circuit High Input	<Ref. to GD(H4DOTC)-172, DTC P0463 — FUEL LEVEL SENSOR CIRCUIT HIGH INPUT —, Diagnostic Trouble Code (DTC) Detecting Criteria.>
P0464	Fuel Level Sensor Circuit Intermittent	<Ref. to GD(H4DOTC)-174, DTC P0464 — FUEL LEVEL SENSOR CIRCUIT INTERMITTENT —, Diagnostic Trouble Code (DTC) Detecting Criteria.>
P0483	Cooling Fan Rationality Check	<Ref. to GD(H4DOTC)-177, DTC P0483 — COOLING FAN RATIONALITY CHECK —, Diagnostic Trouble Code (DTC) Detecting Criteria.>
P0502	Vehicle Speed Sensor Circuit Low Input	<Ref. to GD(H4DOTC)-178, DTC P0502 — VEHICLE SPEED SENSOR CIRCUIT LOW INPUT —, Diagnostic Trouble Code (DTC) Detecting Criteria.>
P0503	Vehicle Speed Sensor Intermittent/Erratic/High	<Ref. to GD(H4DOTC)-180, DTC P0503 — VEHICLE SPEED SENSOR INTERMITTENT/ERRATIC/HIGH —, Diagnostic Trouble Code (DTC) Detecting Criteria.>
P0506	Idle Control System RPM Lower Than Expected	<Ref. to GD(H4DOTC)-182, DTC P0506 — IDLE CONTROL SYSTEM RPM LOWER THAN EXPECTED —, Diagnostic Trouble Code (DTC) Detecting Criteria.>
P0507	Idle Control System RPM Higher Than Expected	<Ref. to GD(H4DOTC)-184, DTC P0507 — IDLE CONTROL SYSTEM RPM HIGHER THAN EXPECTED —, Diagnostic Trouble Code (DTC) Detecting Criteria.>
P0512	Starter Request Circuit	<Ref. to GD(H4DOTC)-186, DTC P0512 — STARTER REQUEST CIRCUIT —, Diagnostic Trouble Code (DTC) Detecting Criteria.>
P0519	Idle Control System Malfunction (Fail-Safe)	<Ref. to GD(H4DOTC)-187, DTC P0519 — IDLE CONTROL SYSTEM MALFUNCTION (FAIL-SAFE) —, Diagnostic Trouble Code (DTC) Detecting Criteria.>
P0545	Exhaust Gas Temperature Sensor Circuit Low — Bank 1 —	<Ref. to GD(H4DOTC)-188, DTC P0545 — EXHAUST GAS TEMPERATURE SENSOR CIRCUIT LOW-BANK 1 —, Diagnostic Trouble Code (DTC) Detecting Criteria.>
P0546	Exhaust Gas Temperature Sensor Circuit High — Bank 1 —	<Ref. to GD(H4DOTC)-190, DTC P0546 — EXHAUST GAS TEMPERATURE SENSOR CIRCUIT HIGH-BANK 1 —, Diagnostic Trouble Code (DTC) Detecting Criteria.>
P0600	CAN Communication Circuit	<Ref. to GD(H4DOTC)-192, DTC P0600 — CAN COMMUNICATION CIRCUIT —, Diagnostic Trouble Code (DTC) Detecting Criteria.>
P0604	Internal Control Module Random Access Memory (RAM) Error	<Ref. to GD(H4DOTC)-193, DTC P0604 — INTERNAL CONTROL MODULE RANDOM ACCESS MEMORY (RAM) ERROR —, Diagnostic Trouble Code (DTC) Detecting Criteria.>
P0605	Internal Control Module Read Only Memory (ROM) Error	<Ref. to GD(H4DOTC)-194, DTC P0605 — INTERNAL CONTROL MODULE READ ONLY MEMORY (ROM) ERROR —, Diagnostic Trouble Code (DTC) Detecting Criteria.>
P0607	Control Module Performance	<Ref. to GD(H4DOTC)-196, DTC P0607 — CONTROL MODULE PERFORMANCE —, Diagnostic Trouble Code (DTC) Detecting Criteria.>

LIST OF DIAGNOSTIC TROUBLE CODE (DTC)

GENERAL DESCRIPTION

DTC	Item	Index
P0638	Throttle Actuator Control Range/Performance (Bank 1)	<Ref. to GD(H4DOTC)-200, DTC P0638 — THROTTLE ACTUATOR CONTROL RANGE/PERFORMANCE (BANK 1) —, Diagnostic Trouble Code (DTC) Detecting Criteria.>
P0691	Cooling Fan 1 Control Circuit Low	<Ref. to GD(H4DOTC)-203, DTC P0691 — COOLING FAN 1 CONTROL CIRCUIT LOW —, Diagnostic Trouble Code (DTC) Detecting Criteria.>
P0692	Cooling Fan 1 Control Circuit High	<Ref. to GD(H4DOTC)-204, DTC P0692 — COOLING FAN 1 CONTROL CIRCUIT HIGH —, Diagnostic Trouble Code (DTC) Detecting Criteria.>
P0700	AT MIL Light up Request	<Ref. to GD(H4DOTC)-205, DTC P0700 — AT MIL LIGHT UP REQUEST —, Diagnostic Trouble Code (DTC) Detecting Criteria.>
P0851	Neutral Switch Input Circuit Low (AT model)	<Ref. to GD(H4DOTC)-206, DTC P0851 — NEUTRAL SWITCH INPUT CIRCUIT LOW (AT MODEL) —, Diagnostic Trouble Code (DTC) Detecting Criteria.>
P0851	Neutral Switch Input Circuit Low (MT model)	<Ref. to GD(H4DOTC)-207, DTC P0851 — NEUTRAL SWITCH INPUT CIRCUIT LOW (MT MODEL) —, Diagnostic Trouble Code (DTC) Detecting Criteria.>
P0852	Neutral Switch Input Circuit High (AT model)	<Ref. to GD(H4DOTC)-208, DTC P0852 — NEUTRAL SWITCH INPUT CIRCUIT HIGH (AT MODEL) —, Diagnostic Trouble Code (DTC) Detecting Criteria.>
P0852	Neutral Switch Input Circuit High (MT model)	<Ref. to GD(H4DOTC)-209, DTC P0852 — NEUTRAL SWITCH INPUT CIRCUIT HIGH (MT MODEL) —, Diagnostic Trouble Code (DTC) Detecting Criteria.>
P1086	Tumble Generated Valve Position Sensor 2 Circuit Low	<Ref. to GD(H4DOTC)-210, DTC P1086 — TUMBLE GENERATED VALVE POSITION SENSOR 2 CIRCUIT LOW —, Diagnostic Trouble Code (DTC) Detecting Criteria.>
P1087	Tumble Generated Valve Position Sensor 2 Circuit High	<Ref. to GD(H4DOTC)-212, DTC P1087 — TUMBLE GENERATED VALVE POSITION SENSOR 2 CIRCUIT HIGH —, Diagnostic Trouble Code (DTC) Detecting Criteria.>
P1088	Tumble Generated Valve Position Sensor 1 Circuit Low	<Ref. to GD(H4DOTC)-214, DTC P1088 — TUMBLE GENERATED VALVE POSITION SENSOR 1 CIRCUIT LOW —, Diagnostic Trouble Code (DTC) Detecting Criteria.>
P1089	Tumble Generated Valve Position Sensor 1 Circuit High	<Ref. to GD(H4DOTC)-216, DTC P1089 — TUMBLE GENERATED VALVE POSITION SENSOR 1 CIRCUIT HIGH —, Diagnostic Trouble Code (DTC) Detecting Criteria.>
P1090	Tumble Generated Valve System 1 (Valve Open)	<Ref. to GD(H4DOTC)-218, DTC P1090 — TUMBLE GENERATED VALVE SYSTEM 1 (VALVE OPEN) —, Diagnostic Trouble Code (DTC) Detecting Criteria.>
P1091	Tumble Generated Valve System 1 (Valve Close)	<Ref. to GD(H4DOTC)-219, DTC P1091 — TUMBLE GENERATED VALVE SYSTEM 1 (VALVE CLOSE) —, Diagnostic Trouble Code (DTC) Detecting Criteria.>
P1092	Tumble Generated Valve System 2 (Valve Open)	<Ref. to GD(H4DOTC)-220, DTC P1092 — TUMBLE GENERATED VALVE SYSTEM 2 (VALVE OPEN) —, Diagnostic Trouble Code (DTC) Detecting Criteria.>
P1093	Tumble Generated Valve System 2 (Valve Close)	<Ref. to GD(H4DOTC)-221, DTC P1093 — TUMBLE GENERATED VALVE SYSTEM 2 (VALVE CLOSE) —, Diagnostic Trouble Code (DTC) Detecting Criteria.>
P1094	Tumble Generated Valve Signal 1 Circuit Malfunction (Open)	<Ref. to GD(H4DOTC)-222, DTC P1094 — TUMBLE GENERATED VALVE SIGNAL 1 CIRCUIT MALFUNCTION (OPEN) —, Diagnostic Trouble Code (DTC) Detecting Criteria.>
P1095	Tumble Generated Valve Signal 1 Circuit Malfunction (Short)	<Ref. to GD(H4DOTC)-224, DTC P1095 — TUMBLE GENERATED VALVE SIGNAL 1 CIRCUIT MALFUNCTION (SHORT) —, Diagnostic Trouble Code (DTC) Detecting Criteria.>
P1096	Tumble Generated Valve Signal 2 Circuit Malfunction (Open)	<Ref. to GD(H4DOTC)-226, DTC P1096 — TUMBLE GENERATED VALVE SIGNAL 2 CIRCUIT MALFUNCTION (OPEN) —, Diagnostic Trouble Code (DTC) Detecting Criteria.>
P1097	Tumble Generated Valve Signal 2 Circuit Malfunction (Short)	<Ref. to GD(H4DOTC)-228, DTC P1097 — TUMBLE GENERATED VALVE SIGNAL 2 CIRCUIT MALFUNCTION (SHORT) —, Diagnostic Trouble Code (DTC) Detecting Criteria.>

LIST OF DIAGNOSTIC TROUBLE CODE (DTC)

GENERAL DESCRIPTION

DTC	Item	Index
P1110	Atmospheric Pressure Sensor Circuit Malfunction (Low Input)	<Ref. to GD(H4DOTC)-230, DTC P1110 — ATMOSPHERIC PRESSURE SENSOR CIRCUIT MALFUNCTION (LOW INPUT) —, Diagnostic Trouble Code (DTC) Detecting Criteria.>
P1111	Atmospheric Pressure Sensor Circuit Malfunction (High Input)	<Ref. to GD(H4DOTC)-231, DTC P1111 — ATMOSPHERIC PRESSURE SENSOR CIRCUIT MALFUNCTION (HIGH INPUT) —, Diagnostic Trouble Code (DTC) Detecting Criteria.>
P1152	O ₂ Sensor Circuit Range/Performance (Low) (Bank1 Sensor1)	<Ref. to GD(H4DOTC)-232, DTC P1152 — O ₂ SENSOR CIRCUIT RANGE/PERFORMANCE (LOW) (BANK1 SENSOR1) —, Diagnostic Trouble Code (DTC) Detecting Criteria.>
P1153	O ₂ Sensor Circuit Range/Performance (High) (Bank1 Sensor1)	<Ref. to GD(H4DOTC)-236, DTC P1153 — O ₂ SENSOR CIRCUIT RANGE/PERFORMANCE (HIGH) (BANK1 SENSOR1) —, Diagnostic Trouble Code (DTC) Detecting Criteria.>
P1160	Return Spring Failure	<Ref. to GD(H4DOTC)-240, DTC P1160 — RETURN SPRING FAILURE —, Diagnostic Trouble Code (DTC) Detecting Criteria.>
P1301	Misfire Detected (High Temperature Exhaust Gas)	<Ref. to GD(H4DOTC)-242, DTC P1301 — MISFIRE DETECTED (HIGH TEMPERATURE EXHAUST GAS) —, Diagnostic Trouble Code (DTC) Detecting Criteria.>
P1312	Exhaust Gas Temperature Sensor Malfunction	<Ref. to GD(H4DOTC)-244, DTC P1312 — EXHAUST GAS TEMPERATURE SENSOR MALFUNCTION —, Diagnostic Trouble Code (DTC) Detecting Criteria.>
P1400	Fuel Tank Pressure Control Solenoid Valve Circuit Low	<Ref. to GD(H4DOTC)-246, DTC P1400 — FUEL TANK PRESSURE CONTROL SOLENOID VALVE CIRCUIT LOW —, Diagnostic Trouble Code (DTC) Detecting Criteria.>
P1420	Fuel Tank Pressure Control Sol. Valve Circuit High	<Ref. to GD(H4DOTC)-248, DTC P1420 — FUEL TANK PRESSURE CONTROL SOL. VALVE CIRCUIT HIGH —, Diagnostic Trouble Code (DTC) Detecting Criteria.>
P1443	Vent Control Solenoid Valve Function Problem	<Ref. to GD(H4DOTC)-250, DTC P1443 — VENT CONTROL SOLENOID VALVE FUNCTION PROBLEM —, Diagnostic Trouble Code (DTC) Detecting Criteria.>
P1446	Fuel Tank Sensor Control Valve Circuit Low	<Ref. to GD(H4DOTC)-252, DTC P1446 — FUEL TANK SENSOR CONTROL VALVE CIRCUIT LOW —, Diagnostic Trouble Code (DTC) Detecting Criteria.>
P1447	Fuel Tank Sensor Control Valve Circuit High	<Ref. to GD(H4DOTC)-254, DTC P1447 — FUEL TANK SENSOR CONTROL VALVE CIRCUIT HIGH —, Diagnostic Trouble Code (DTC) Detecting Criteria.>
P1448	Fuel Tank Sensor Control Valve Range/Performance	<Ref. to GD(H4DOTC)-256, DTC P1448 — FUEL TANK SENSOR CONTROL VALVE RANGE PERFORMANCE —, Diagnostic Trouble Code (DTC) Detecting Criteria.>
P1491	Positive Crankcase Ventilation (Blow-by) Function Problem	<Ref. to GD(H4DOTC)-260, DTC P1491 — POSITIVE CRANKCASE VENTILATION (BLOW-BY) FUNCTION PROBLEM —, Diagnostic Trouble Code (DTC) Detecting Criteria.>
P1518	Starter Switch Circuit Low Input	<Ref. to GD(H4DOTC)-262, DTC P1518 — STARTER SWITCH CIRCUIT LOW INPUT —, Diagnostic Trouble Code (DTC) Detecting Criteria.>
P1544	Exhaust Gas Temperature Too High	<Ref. to GD(H4DOTC)-263, DTC P1544 — EXHAUST GAS TEMPERATURE TOO HIGH —, Diagnostic Trouble Code (DTC) Detecting Criteria.>
P1560	Back-Up Voltage Circuit Malfunction	<Ref. to GD(H4DOTC)-264, DTC P1560 — BACK-UP VOLTAGE CIRCUIT MALFUNCTION —, Diagnostic Trouble Code (DTC) Detecting Criteria.>
P2088	OCV Solenoid Valve Signal A Circuit Open (Bank 1)	<Ref. to GD(H4DOTC)-265, DTC P2088 — OCV SOLENOID VALVE SIGNAL A CIRCUIT OPEN (BANK 1) —, Diagnostic Trouble Code (DTC) Detecting Criteria.>
P2089	OCV Solenoid Valve Signal A Circuit Short (Bank 1)	<Ref. to GD(H4DOTC)-268, DTC P2089 — OCV SOLENOID VALVE SIGNAL A CIRCUIT SHORT (BANK 1) —, Diagnostic Trouble Code (DTC) Detecting Criteria.>
P2092	OCV Solenoid Valve Signal A Circuit Open (Bank 2)	<Ref. to GD(H4DOTC)-270, DTC P2092 — OCV SOLENOID VALVE SIGNAL A CIRCUIT OPEN (BANK 2) —, Diagnostic Trouble Code (DTC) Detecting Criteria.>

LIST OF DIAGNOSTIC TROUBLE CODE (DTC)

GENERAL DESCRIPTION

DTC	Item	Index
P2093	OCV Solenoid Valve Signal A Circuit Short (Bank 2)	<Ref. to GD(H4DOTC)-272, DTC P2093 — OCV SOLENOID VALVE SIGNAL A CIRCUIT SHORT (BANK 2) —, Diagnostic Trouble Code (DTC) Detecting Criteria.>
P2096	Post Catalyst Fuel Trim System Too Lean Bank 1	<Ref. to GD(H4DOTC)-274, DTC P2096 — POST CATALYST FUEL TRIM SYSTEM TOO LEAN BANK 1 —, Diagnostic Trouble Code (DTC) Detecting Criteria.>
P2097	Post Catalyst Fuel Trim System Too Rich Bank 1	<Ref. to GD(H4DOTC)-276, DTC P2097 — POST CATALYST FUEL TRIM SYSTEM TOO RICH BANK 1 —, Diagnostic Trouble Code (DTC) Detecting Criteria.>
P2101	Throttle Actuator Control Motor Circuit Range/Performance	<Ref. to GD(H4DOTC)-278, DTC P2101 — THROTTLE ACTUATOR CONTROL MOTOR CIRCUIT RANGE/PERFORMANCE —, Diagnostic Trouble Code (DTC) Detecting Criteria.>
P2102	Throttle Actuator Control Motor Circuit Low	<Ref. to GD(H4DOTC)-280, DTC P2102 — THROTTLE ACTUATOR CONTROL MOTOR CIRCUIT LOW —, Diagnostic Trouble Code (DTC) Detecting Criteria.>
P2103	Throttle Actuator Control Motor Circuit High	<Ref. to GD(H4DOTC)-282, DTC P2103 — THROTTLE ACTUATOR CONTROL MOTOR CIRCUIT HIGH —, Diagnostic Trouble Code (DTC) Detecting Criteria.>
P2109	Throttle/Pedal Position Sensor A Minimum Stop Performance	<Ref. to GD(H4DOTC)-284, DTC P2109 — THROTTLE/PEDAL POSITION SENSOR A MINIMUM STOP PERFORMANCE —, Diagnostic Trouble Code (DTC) Detecting Criteria.>
P2122	Throttle/Pedal Position Sensor/Switch “D” Circuit Low Input	<Ref. to GD(H4DOTC)-286, DTC P2122 — THROTTLE/PEDAL POSITION SENSOR/SWITCH “D” CIRCUIT LOW INPUT —, Diagnostic Trouble Code (DTC) Detecting Criteria.>
P2123	Throttle/Pedal Position Sensor/Switch “D” Circuit High Input	<Ref. to GD(H4DOTC)-288, DTC P2123 — THROTTLE/PEDAL POSITION SENSOR/SWITCH “D” CIRCUIT HIGH INPUT —, Diagnostic Trouble Code (DTC) Detecting Criteria.>
P2127	Throttle/Pedal Position Sensor/Switch “E” Circuit Low Input	<Ref. to GD(H4DOTC)-290, DTC P2127 — THROTTLE/PEDAL POSITION SENSOR/SWITCH “E” CIRCUIT LOW INPUT —, Diagnostic Trouble Code (DTC) Detecting Criteria.>
P2128	Throttle/Pedal Position Sensor/Switch “E” Circuit High Input	<Ref. to GD(H4DOTC)-292, DTC P2128 — THROTTLE/PEDAL POSITION SENSOR/SWITCH “E” CIRCUIT HIGH INPUT —, Diagnostic Trouble Code (DTC) Detecting Criteria.>
P2135	Throttle/Pedal Position Sensor/Switch “A”/“B” Voltage Rationality	<Ref. to GD(H4DOTC)-294, DTC P2135 — THROTTLE/PEDAL POSITION SENSOR/SWITCH “A” / “B” VOLTAGE RATIONALITY —, Diagnostic Trouble Code (DTC) Detecting Criteria.>
P2138	Throttle/Pedal Position Sensor/Switch “D”/“E” Voltage Rationality	<Ref. to GD(H4DOTC)-296, DTC P2138 — THROTTLE/PEDAL POSITION SENSOR/SWITCH “D” / “E” VOLTAGE RATIONALITY —, Diagnostic Trouble Code (DTC) Detecting Criteria.>

LIST OF DIAGNOSTIC TROUBLE CODE (DTC)

GENERAL DESCRIPTION

MEMO:

DIAGNOSTIC TROUBLE CODE (DTC) DETECTING CRITERIA

GENERAL DESCRIPTION

2. Diagnostic Trouble Code (DTC) Detecting Criteria

A: DTC P0011 — “A” CAMSHAFT POSITION - TIMING OVER-ADVANCED OR SYSTEM PERFORMANCE (BANK 1) —

1. OUTLINE OF DIAGNOSIS

Detect the malfunction of AVCS system.

- 1) Judge NG when the amount of AVCS actual timing advance does not approach to the amount of AVCS target timing advance.
- 2) Judge NG when the most retarded learning value is outside of the normal range.

2. COMPONENT DESCRIPTION

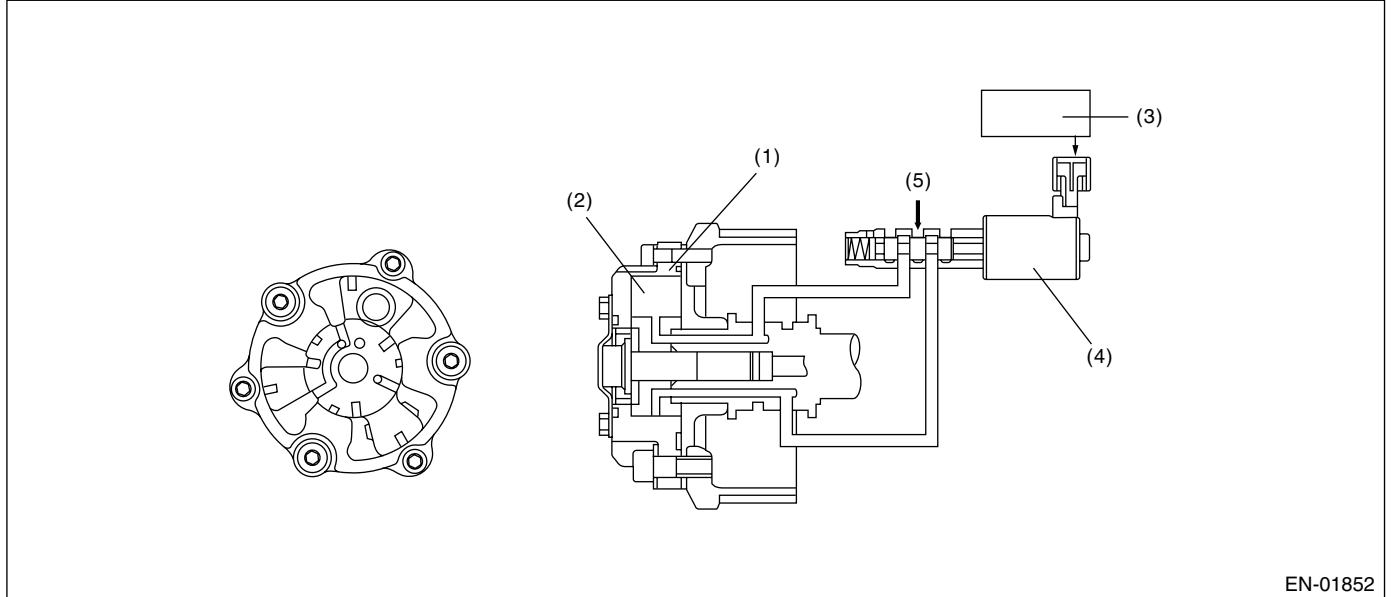

EN-01852

(1) AVCS timing controller

(3) Engine control module (ECM)

(5) Oil pressure

(2) Vane

(4) Oil flow control valve

3. ENABLE CONDITION (For abnormality judgment only)

Secondary Parameters	Enable Conditions
Abnormality judgement (1)	
Battery voltage	$\geq 10.9 \text{ V}$
Engine speed	$\geq 1500 \text{ rpm}$
Coolant temperature	$\geq 60^\circ\text{C}$ (140 °F)
Abnormality judgement (2)	
Battery voltage	$\geq 10.9 \text{ V}$
Engine speed	$\geq 500 \text{ rpm}$
Coolant temperature	$\geq 60^\circ\text{C}$ (140 °F)

4. GENERAL DRIVING CYCLE

- 1) Always perform the diagnosis after idling when the engine speed is more than 1500 rpm.
- 2) Always perform the diagnosis after warming up the engine when the engine speed is more than 500 rpm.

DIAGNOSTIC TROUBLE CODE (DTC) DETECTING CRITERIA

GENERAL DESCRIPTION

5. DIAGNOSTIC METHOD

- 1) Judge NG when the difference of the amount of AVCS target timing advance and the amount of AVCS actual timing advance becomes large.
- 2) Judge NG when the most retarded learning value is outside of the normal range.

• Abnormality Judgment

Judge NG when the continuous time of completing the malfunction criteria below becomes more than 20 seconds.

• Judgment Value

Malfunction Criteria	Threshold Value
(1) Judgement value AVCS target position – AVCS actual position	$\geq 7.5^\circ$
(2) Judgement value AVCS control Most timing retard learning value	During most timing retard learning $< -29.5^\circ\text{CA}$ or $> 29.5^\circ\text{CA}$

Time Needed for Diagnosis: 10 seconds

Malfunction Indicator Light Illumination: Illuminates when malfunction occurs in 2 continuous driving cycles.

• Normality Judgment

Judge OK and clear the NG when the continuous time of completing the malfunction criteria below becomes more than 1 second.

• Judgment Value

Malfunction Criteria	Threshold Value
(1) Judgement value AVCS control Amount of AVCS target timing advance AVCS target position – AVCS actual position	During feedback $5 - 30^\circ\text{CA}$ $< 10^\circ$
(2) Judgement value Most timing retard learning value	$-29.5 - 29.5^\circ\text{CA}$

6. DTC CLEAR CONDITION

- When the OK idling cycle was completed 40 times in a row
- When “Clear Memory” was performed

7. MALFUNCTION INDICATOR LIGHT CLEAR CONDITION

- When the OK driving cycle was completed 3 times in a row
- When “Clear Memory” was performed

DIAGNOSTIC TROUBLE CODE (DTC) DETECTING CRITERIA

GENERAL DESCRIPTION

8. FAIL SAFE

- Ignition timing whole learning compensation:
 - Enter the initial value (whole learning compensation factor = 0.5, Variable amount of whole learning compensation factor = 0.25) to the whole learning compensation factor and variable amount of whole learning compensation factor when IG OFF, and then make the whole learning incomplete.
 - Enter the initial value (whole learning compensation factor = 0.5, Variable amount of whole learning compensation factor = 0.25) to the whole learning compensation factor and variable amount of whole learning compensation factor when making a normality judgment from abnormality judgment, and then make the whole learning incomplete.
- Ignition timing partial learning compensation:
 - Enter the initial value (0°CA) to the compensation value of partial learning zone when IG OFF.
 - Enter the initial value (0°CA) to the compensation value of partial learning zone when making a normality judgment from abnormality judgment.
- AVCS control: Most timing retard learning is not complete or most timing retard learning completion is not experienced.
- ISC feedback compensation: Do not perform the AVCS actual timing advance compensation. Make the OCV driving Duty to be the given value (9.36%).

9. ECM OPERATING AT DTC SETTING

Memorize the freeze frame data. (For test mode \$02)

DIAGNOSTIC TROUBLE CODE (DTC) DETECTING CRITERIA

GENERAL DESCRIPTION

B: DTC P0021 — “A” CAMSHAFT POSITION - TIMING OVER-ADVANCED OR SYSTEM PERFORMANCE (BANK 2) —

NOTE:

For the diagnostic procedure, refer to DTC P0011. <Ref. to GD(H4DOTC)-10, DTC P0011 — “A” CAMSHAFT POSITION - TIMING OVER-ADVANCED OR SYSTEM PERFORMANCE (BANK 1) —.>

DIAGNOSTIC TROUBLE CODE (DTC) DETECTING CRITERIA

GENERAL DESCRIPTION

C: DTC P0030 — HO2S HEATER CONTROL CIRCUIT (BANK 1 SENSOR 1) —

1. OUTLINE OF DIAGNOSIS

Detect the malfunction of front oxygen (A/F) sensor heater.

Judge NG when impedance of front oxygen (A/F) sensor is larger than the standard value by referring to the engine condition such as fuel shut-off in deceleration, etc.

2. COMPONENT DESCRIPTION

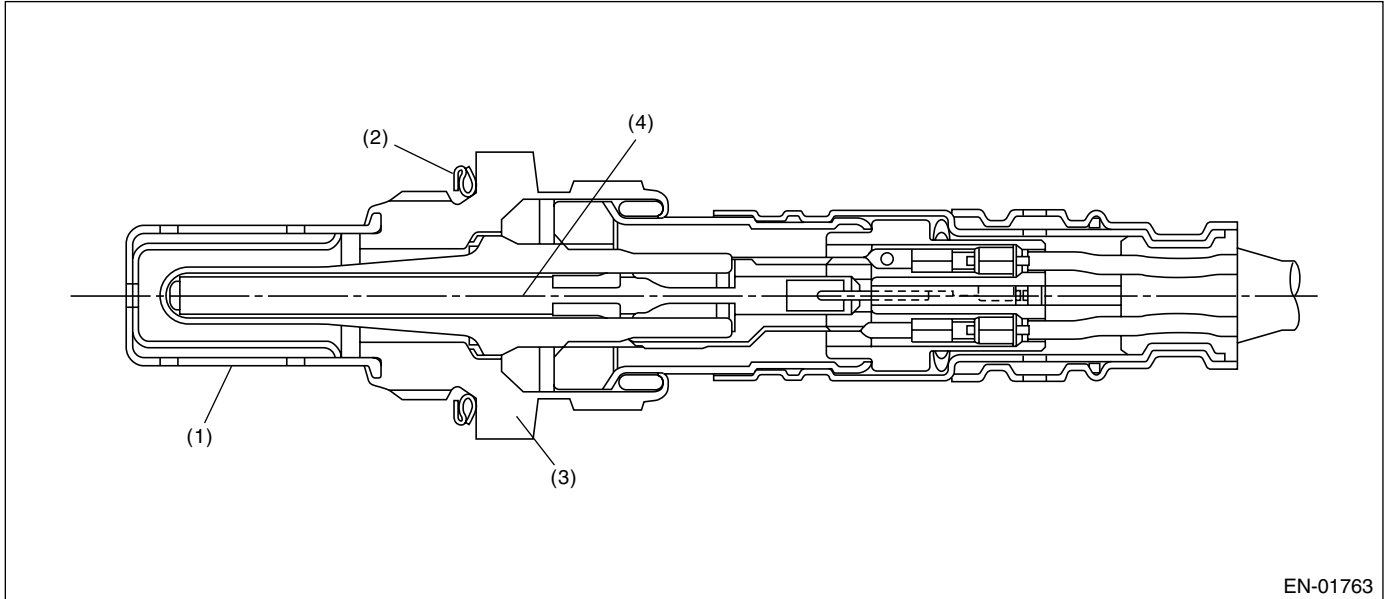

EN-01763

- (1) Protection tube
- (2) Gasket
- (3) Sensor housing
- (4) Ceramic heater

3. ENABLE CONDITION

Secondary Parameters	Enable Conditions
Time needed for all secondary parameters to be in enable conditions	60 seconds or more
Battery voltage	> 10.9 V
After fuel shut-off	20 seconds or more
Front oxygen (A/F) sensor heater control duty \geq 70%	Experienced

4. GENERAL DRIVING CYCLE

Perform diagnosis continuously in 60 seconds after starting engine.

DIAGNOSTIC TROUBLE CODE (DTC) DETECTING CRITERIA

GENERAL DESCRIPTION

5. DIAGNOSTIC METHOD

Judge NG when the continuous time of completing the malfunction criteria below becomes more than the time needed for diagnosis (10 seconds). Judge OK and clear NG when the continuous time of not completing the malfunction criteria below becomes more than the time needed for diagnosis (10 seconds).

Judgment Value

Malfunction Criteria	Threshold Value
Impedance of front oxygen (A/F) sensor	> 50 Ω

Time Needed for Diagnosis: 10 seconds

Malfunction Indicator Light Illumination: Illuminates when malfunction occurs in 2 continuous driving cycles.

6. DTC CLEAR CONDITION

- When the OK idling cycle was completed 40 times in a row
- When "Clear Memory" was performed

7. MALFUNCTION INDICATOR LIGHT CLEAR CONDITION

- When the OK driving cycle was completed 3 times in a row
- When "Clear Memory" was performed

8. FAIL SAFE

- Front oxygen (A/F) sensor main learning correction: Not allowed to calculate
- Correction when re-starting at high temperature: Normally minimum value 0.3 \rightarrow 0
- Purge control: Not allowed to purge

9. ECM OPERATING AT DTC SETTING

Memorize the freeze frame data. (For test mode \$02)

DIAGNOSTIC TROUBLE CODE (DTC) DETECTING CRITERIA

GENERAL DESCRIPTION

D: DTC P0031 — HO₂S HEATER CONTROL CIRCUIT LOW (BANK 1 SENSOR 1)

1. OUTLINE OF DIAGNOSIS

Detect the open or short circuit of heater.

The heater conducts the duty control. The output terminal voltage at ON becomes 0 V, and the output terminal voltage at OFF becomes battery voltage.

Judge NG when the terminal voltage remains to be Low.

2. COMPONENT DESCRIPTION

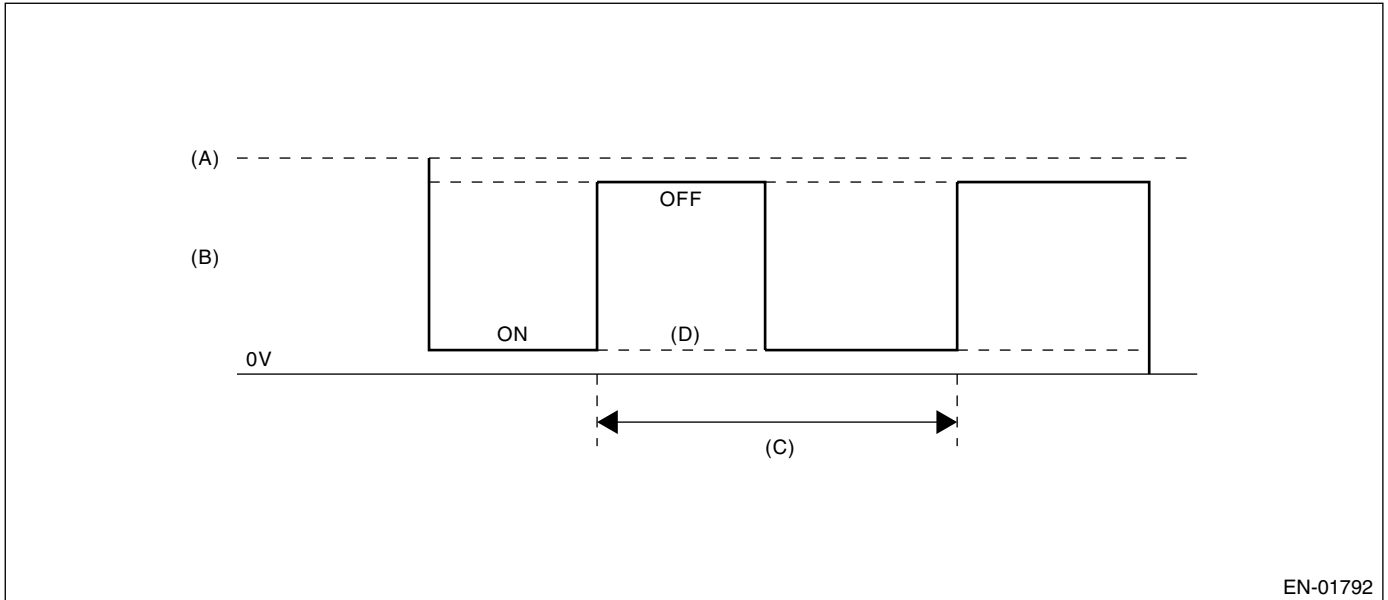

- (A) Battery voltage
(B) Front oxygen (A/F) sensor heater output voltage
(C) 128 milliseconds
(D) Low abnormality output voltage

3. ENABLE CONDITION

Secondary Parameters	Enable Conditions
Battery voltage	≥ 10.9 V

4. GENERAL DRIVING CYCLE

Always perform diagnosis continuously.

DIAGNOSTIC TROUBLE CODE (DTC) DETECTING CRITERIA

GENERAL DESCRIPTION

5. DIAGNOSTIC METHOD

• Abnormality Judgment

Judge NG when the continuous time of completing the malfunction criteria below becomes more than 1 second (8 cycles).

• Judgment Value

Malfunction Criteria	Threshold Value
Output voltage level	Low
Front oxygen (A/F) sensor heater control duty	< 87.5%

Time Needed for Diagnosis: 1 second

Malfunction Indicator Light Illumination: Illuminates as soon as malfunction occurs.

• Normality Judgment

Judge OK and clear the NG when all the malfunction criteria below are completed.

• Judgment Value

Malfunction Criteria	Threshold Value
Output voltage level	High

6. DTC CLEAR CONDITION

- When the OK idling cycle was completed 40 times in a row
- When "Clear Memory" was performed

7. MALFUNCTION INDICATOR LIGHT CLEAR CONDITION

- When the OK driving cycle was completed 3 times in a row
- When "Clear Memory" was performed

8. FAIL SAFE

- Front oxygen (A/F) sensor activation judgment: Front oxygen (A/F) sensor full activation is not complete, or front oxygen (A/F) sensor half activation is not complete.
- A/F main learning: Not allowed to calculate the A/F main learning compensation factor.
- Compensation when starting the engine at high temperature: Make the MIN value to be 0 from 0.3 normally.
- Purge control: Not allowed to purge.

9. ECM OPERATING AT DTC SETTING

Memorize the freeze frame data. (For test mode \$02)

DIAGNOSTIC TROUBLE CODE (DTC) DETECTING CRITERIA

GENERAL DESCRIPTION

E: DTC P0032 — HO₂S HEATER CONTROL CIRCUIT HIGH (BANK 1 SENSOR 1) —

1. OUTLINE OF DIAGNOSIS

Detect the open or short circuit of heater.

The heater conducts the duty control. The output terminal voltage at ON becomes 0 V, and the output terminal voltage at OFF becomes battery voltage.

Judge NG when the terminal voltage remains to be High.

2. COMPONENT DESCRIPTION

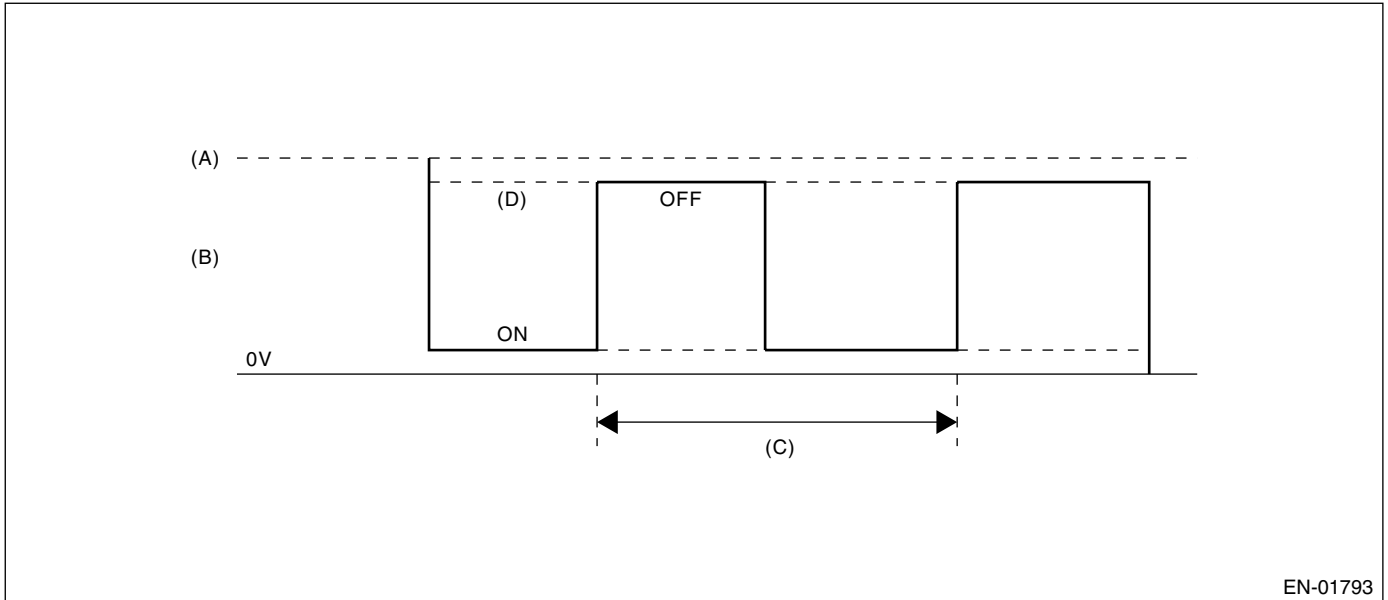

- (A) Battery voltage
(B) Front oxygen (A/F) sensor heater output voltage
(C) 128 milliseconds
(D) High abnormality output voltage

3. ENABLE CONDITION

Secondary Parameters	Enable Conditions
Battery voltage	≥ 10.9 V

4. GENERAL DRIVING CYCLE

Always perform diagnosis continuously.

DIAGNOSTIC TROUBLE CODE (DTC) DETECTING CRITERIA

GENERAL DESCRIPTION

5. DIAGNOSTIC METHOD

• Abnormality Judgment

Judge NG when the continuous time of completing the malfunction criteria below becomes 1 second (8 cycles).

• Judgment Value

Malfunction Criteria	Threshold Value
Output voltage level	High
Front oxygen (A/F) sensor heater control duty	≥ 12.5%

Time Needed for Diagnosis: 1 second

Malfunction Indicator Light Illumination: Illuminates as soon as malfunction occurs.

• Normality Judgment

Judge OK and clear the NG when all the malfunction criteria below are completed.

• Judgment Value

Malfunction Criteria	Threshold Value
Output voltage level	Low

6. DTC CLEAR CONDITION

- When the OK idling cycle was completed 40 times in a row
- When "Clear Memory" was performed

7. MALFUNCTION INDICATOR LIGHT CLEAR CONDITION

- When the OK driving cycle was completed 3 times in a row
- When "Clear Memory" was performed

8. FAIL SAFE

- Front oxygen (A/F) sensor activation judgment: Front oxygen (A/F) sensor full activation is not complete, or front oxygen (A/F) sensor half activation is not complete.
- A/F main learning: Not allowed to calculate the A/F main learning compensation factor.
- Compensation when starting the engine at high temperature: Make the MIN value to be 0 from 0.3 normally.
- Purge control: Not allowed to purge.

9. ECM OPERATING AT DTC SETTING

Memorize the freeze frame data. (For test mode \$02)

DIAGNOSTIC TROUBLE CODE (DTC) DETECTING CRITERIA

GENERAL DESCRIPTION

F: DTC P0037 — HO2S HEATER CONTROL CIRCUIT LOW (BANK 1 SENSOR 2)

1. OUTLINE OF DIAGNOSIS

Detect open or short circuit of rear oxygen sensor heater.

Rear oxygen sensor heater conducted the duty control, and the output terminal voltage at ON is 0 V and the output terminal voltage at OFF is the battery voltage.

Judge NG when the terminal voltage remains to be Low.

2. COMPONENT DESCRIPTION

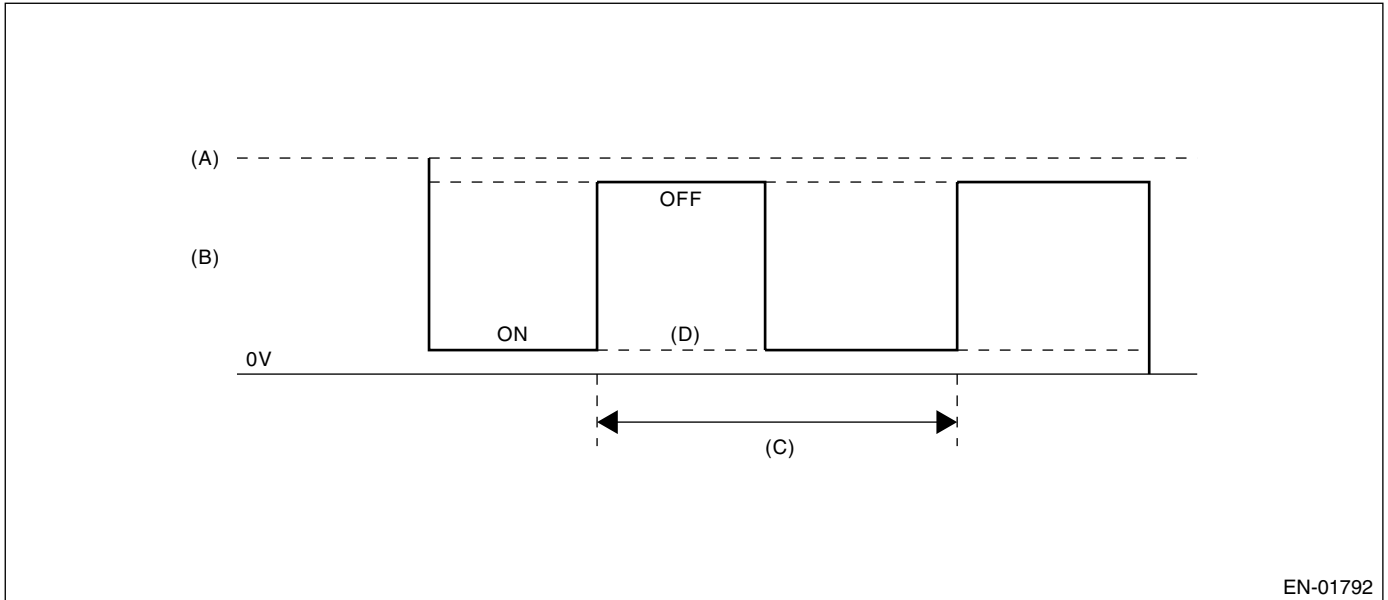

- (A) Battery voltage
- (B) Rear oxygen sensor heater output voltage
- (C) 256 milliseconds (cycles)
- (D) Low malfunction voltage

3. ENABLE CONDITION

Secondary Parameters	Enable Conditions
Battery voltage	> 10.9 V

4. GENERAL DRIVING CYCLE

Perform the diagnosis continuously after engine starting.

DIAGNOSTIC TROUBLE CODE (DTC) DETECTING CRITERIA

GENERAL DESCRIPTION

5. DIAGNOSTIC METHOD

• Abnormality Judgment

Judge NG when the continuous time of completing all the malfunction criteria below becomes more than 2560 millisecond (10 cycles).

• Judgment Value

Malfunction Criteria	Threshold Value
Output voltage level	Low
Rear oxygen sensor heater control duty	< 75%

Time Needed for Diagnosis: 2.56 seconds

Malfunction Indicator Light Illumination: Illuminates when malfunction occurs in 2 continuous driving cycles.

• Normality Judgment

Judge OK and clear the NG when all the malfunction criteria below are completed.

• Judgment Value

Malfunction Criteria	Threshold Value
Output voltage level	High

6. DTC CLEAR CONDITION

- When the OK idling cycle was completed 40 times in a row
- When "Clear Memory" was performed

7. MALFUNCTION INDICATOR LIGHT CLEAR CONDITION

- When the OK driving cycle was completed 3 times in a row
- When "Clear Memory" was performed

8. FAIL SAFE

Sub feedback control: Not allowed

9. ECM OPERATING AT DTC SETTING

Memorize the freeze frame data. (For test mode \$02)

DIAGNOSTIC TROUBLE CODE (DTC) DETECTING CRITERIA

GENERAL DESCRIPTION

G: DTC P0038 — HO₂S HEATER CONTROL CIRCUIT HIGH (BANK 1 SENSOR 2) —

1. OUTLINE OF DIAGNOSIS

Detect open or short circuit of rear oxygen heater.

Rear oxygen heater conducted the duty control, and the output terminal voltage at ON is 0 V and the output terminal voltage at OFF is the battery voltage.

Judge NG when the terminal voltage remains to be High.

2. COMPONENT DESCRIPTION

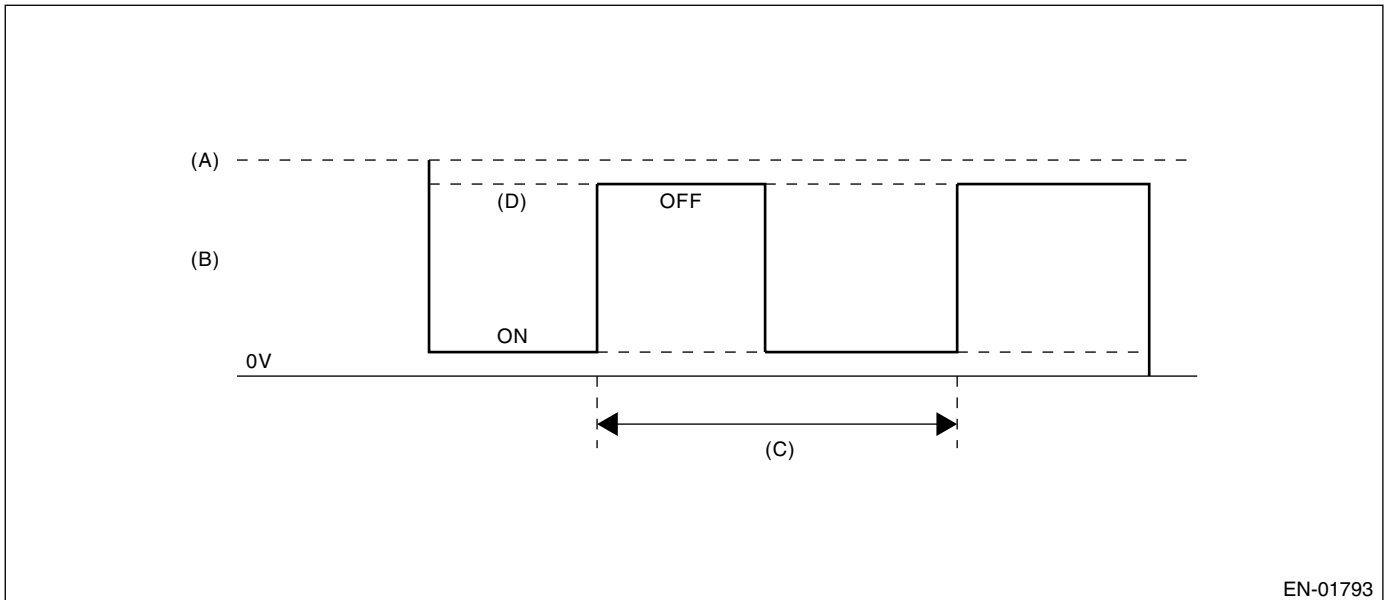

- (A) Battery voltage (C) 256 milliseconds (cycle)
(B) Rear oxygen sensor heater output voltage (D) High malfunction voltage

3. ENABLE CONDITION

Secondary Parameters	Enable Conditions
Battery voltage	> 10.9 V

4. GENERAL DRIVING CYCLE

Perform the diagnosis continuously after engine starting.

DIAGNOSTIC TROUBLE CODE (DTC) DETECTING CRITERIA

GENERAL DESCRIPTION

5. DIAGNOSTIC METHOD

• Abnormality Judgment

Judge NG when the continuous time of completing all the malfunction criteria below becomes more than 2560 milliseconds (10 cycles).

• Judgment Value

Malfunction Criteria	Threshold Value
Output voltage level	High
Rear oxygen sensor heater control duty	≥ 25%

Time Needed for Diagnosis: 2.56 seconds

Malfunction Indicator Light Illumination: Illuminates when malfunction occurs in 2 continuous driving cycles.

• Normality Judgment

Judge OK and clear the NG when all the malfunction criteria below are completed.

• Judgment Value

Malfunction Criteria	Threshold Value
Output voltage level	Low

6. DTC CLEAR CONDITION

- When the OK idling cycle was completed 40 times in a row
- When "Clear Memory" was performed

7. MALFUNCTION INDICATOR LIGHT CLEAR CONDITION

- When the OK driving cycle was completed 3 times in a row
- When "Clear Memory" was performed

8. FAIL SAFE

Sub feedback control: Not allowed

9. ECM OPERATING AT DTC SETTING

Memorize the freeze frame data. (For test mode \$02)

DIAGNOSTIC TROUBLE CODE (DTC) DETECTING CRITERIA

GENERAL DESCRIPTION

H: DTC P0068 — MANIFOLD PRESSURE SENSOR RANGE/PERFORMANCE —

1. OUTLINE OF DIAGNOSIS

Detect the malfunction of intake manifold pressure sensor output property. Judge NG when the intake air pressure AD value is Low whereas it seemed to be High from the viewpoint of engine condition, or when it is High whereas it seemed to be Low from the engine condition.

2. COMPONENT DESCRIPTION

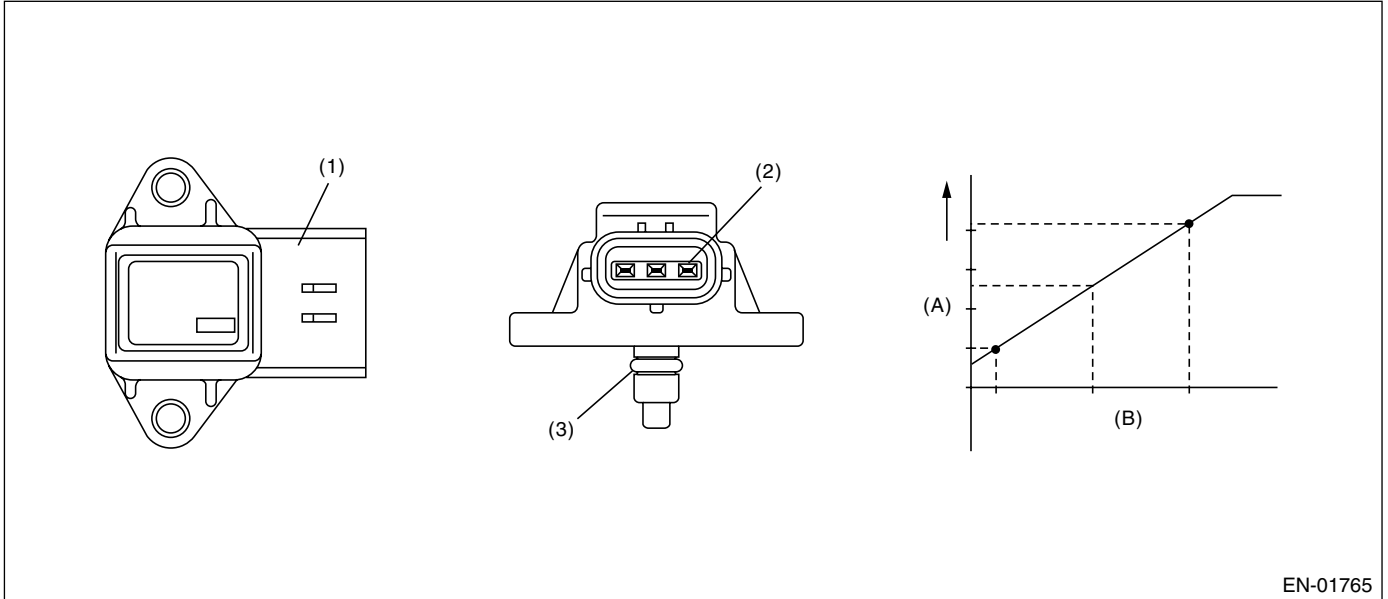

EN-01765

(1) Connector
(2) Terminal

(3) O-ring

(A) Output voltage
(B) Absolute pressure

3. ENABLE CONDITION

Secondary Parameters	Enable Conditions
Engine coolant temperature	$\geq 75^{\circ}\text{C}$ (167°F)

4. GENERAL DRIVING CYCLE

Perform the diagnosis continuously after idling.

DIAGNOSTIC TROUBLE CODE (DTC) DETECTING CRITERIA

GENERAL DESCRIPTION

5. DIAGNOSTIC METHOD

• Abnormality Judgment

Judge NG when either Low side or High side becomes NG. Judge NG when the continuous time of completing the malfunction criteria below becomes more than 3 seconds.

• Judgment Value

Malfunction Criteria	Threshold Value
Low side	
Engine speed	< 2500 rpm
Throttle position	≥ 10°
Output voltage	< 1.0 V
High side	
Engine speed	600 ←→ 900 rpm
Throttle position	< 1.3°
Output voltage	≥ 2.6 V

Time Needed for Diagnosis: 3 seconds

Malfunction Indicator Light Illumination: Illuminates when malfunction occurs in 2 continuous driving cycles.

• Normality Judgment

Judge OK and clear the NG when both Low side and High side become OK. Judge OK when the malfunction criteria below are completed.

• Judgment Value

Malfunction Criteria	Threshold Value
Low side	
Engine speed	< 2500 rpm
Throttle position	≥ 10°
Output voltage	≥ 1.0 V
High side	
Engine speed	600 ←→ 900 rpm
Throttle position	< 1.3°
Output voltage	< 2.6 V

6. DTC CLEAR CONDITION

- When the OK idling cycle was completed 40 times in a row
- When "Clear Memory" was performed

7. MALFUNCTION INDICATOR LIGHT CLEAR CONDITION

- When the OK driving cycle was completed 3 times in a row
- When "Clear Memory" was performed

8. FAIL SAFE

- Intake manifold pressure sensor process: Estimate the pressure from engine load.
- ISC feedback: Not allowed to calculate the amount of feedback.
- Heavy fuel judgment: Not allowed to carry out the heavy judgment.
- Fuel cut control: Not allowed to cut the over pressure charged fuel.

9. ECM OPERATING AT DTC SETTING

Memorize the freeze frame data. (For test mode \$02)

DIAGNOSTIC TROUBLE CODE (DTC) DETECTING CRITERIA

GENERAL DESCRIPTION

I: DTC P0101 — MASS OR VOLUME AIR FLOW CIRCUIT RANGE/PERFORMANCE —

1. OUTLINE OF DIAGNOSIS

Detect the malfunction of air flow sensor output property. Judge Low side NG when the air flow voltage indicates low value in spite of the driving condition that the air flow voltage might be high; otherwise, judge High side NG when the air flow voltage indicates high value in spite of the driving condition that the air flow voltage might be low. Judge air flow sensor property NG when the Low side or High side becomes NG.

2. COMPONENT DESCRIPTION

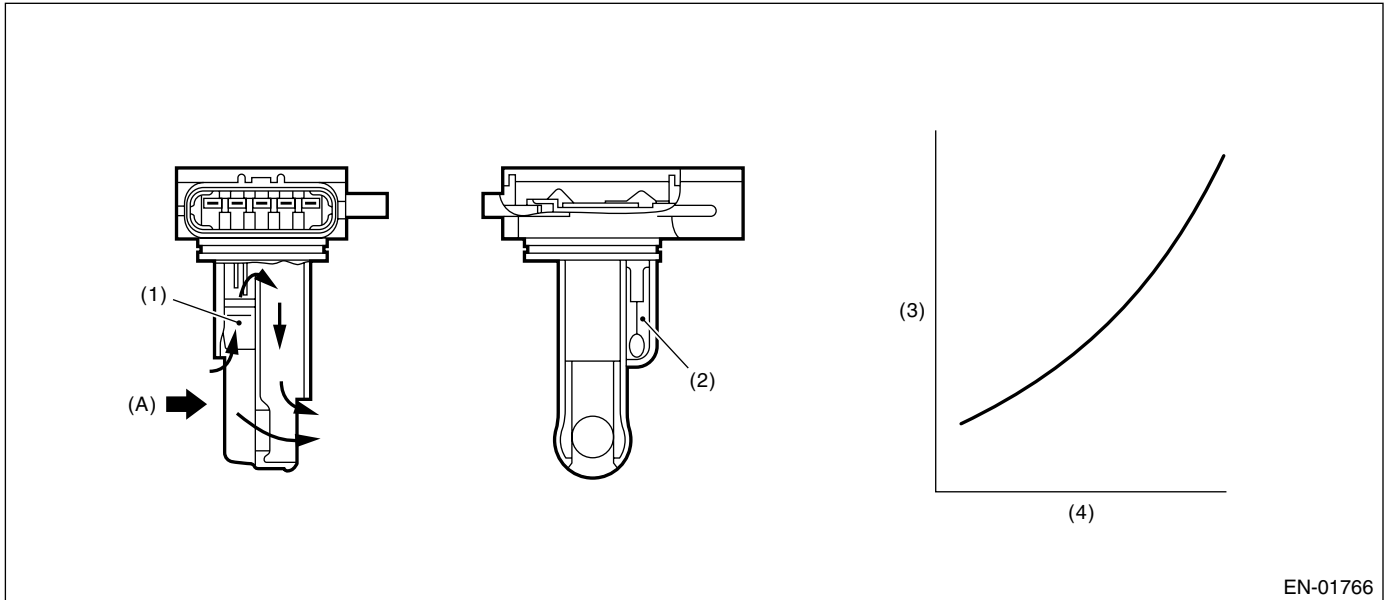

EN-01766

(1) Air flow sensor

(2) Intake air temperature sensor

(3) Voltage (V)

(4) Intake air volume (kg (lb)/s)

(A) Air

3. ENABLE CONDITION

Secondary Parameters	Enable Conditions
Engine coolant temperature	$\geq 75^{\circ}\text{C}$ (167°F)

4. GENERAL DRIVING CYCLE

Perform the diagnosis continuously after idling.

DIAGNOSTIC TROUBLE CODE (DTC) DETECTING CRITERIA

GENERAL DESCRIPTION

5. DIAGNOSTIC METHOD

• Abnormality Judgment

Judge NG when the continuous time of completing the malfunction criteria below becomes more than the time needed for diagnosis.

• Judgment Value

Malfunction Criteria	Threshold Value
Low side NG	
Output voltage	< 1.5 V
Engine speed	≥ 2500 rpm
Throttle angle	≥ 15°
Intake manifold pressure	≥ 53.3 kPa (400 mmHg, 15.7 inHg)
High side NG	
Output voltage	≥ 2.5 V
Engine speed	550 ←→ 900 rpm
Throttle angle	< 1.92°
Intake manifold pressure	< 46.7 kPa (350 mmHg, 13.8 inHg)

Time Needed for Diagnosis:

Low side	3 seconds
High side	10 seconds

Malfunction Indicator Light Illumination: Illuminates when malfunction occurs in 2 continuous driving cycles.

• Normality Judgment

Judge OK the when the malfunction criteria below are completed.

• Judgment Value

Malfunction Criteria	Threshold Value
Low side NG	
Output voltage	≥ 1.5 V
Engine speed	≥ 2500 rpm
Throttle angle	≥ 15°
Intake manifold pressure	≥ 53.3 kPa (400 mmHg, 15.7 inHg)
High side NG	
Output voltage	< 2.5 V
Engine speed	550 ←→ 900 rpm
Throttle angle	< 1.92°
Intake manifold pressure	< 46.7 kPa (350 mmHg, 13.8 inHg)

6. DTC CLEAR CONDITION

- When the OK idling cycle was completed 40 times in a row
- When "Clear Memory" was performed

7. MALFUNCTION INDICATOR LIGHT CLEAR CONDITION

- When the OK driving cycle was completed 3 times in a row
- When "Clear Memory" was performed

DIAGNOSTIC TROUBLE CODE (DTC) DETECTING CRITERIA

GENERAL DESCRIPTION

8. FAIL SAFE

- Air flow meter: Engine load is normally calculated by manifold pressure and engine speed; however, calculated only by manifold pressure.
- EVAP conc. learning (fuel): Not allowed to learn.
- Knock compensation:
 - Knock compensation final timing advance and retard value = knock compensation + whole learning compensation value + partial learning compensation value.
 - At normal: knock compensation = 0°CA is fixed.
 - At trouble: knock compensation ≠ 0°CA is fixed. (Retard max. 12°CA at knock.)
 - Not allowed to update the whole learning compensation factor.
 - Not allowed to calculate the partial learning zone compensation value.
- ISC control: Make the open loop compensation to be the given value (1 g (0.04 oz)/s). Stop calculating the throttle sensor temperature compensation. (Hold the previous value.)
- Purge control: Not allowed to purge.

9. ECM OPERATING AT DTC SETTING

Memorize the freeze frame data. (For test mode \$02)

DIAGNOSTIC TROUBLE CODE (DTC) DETECTING CRITERIA

GENERAL DESCRIPTION

MEMO:

DIAGNOSTIC TROUBLE CODE (DTC) DETECTING CRITERIA

GENERAL DESCRIPTION

J: DTC P0102 — MASS OR VOLUME AIR FLOW CIRCUIT LOW INPUT —

1. OUTLINE OF DIAGNOSIS

Detect the open or short circuit of air flow sensor. Judge NG when out of the standard value.

2. COMPONENT DESCRIPTION

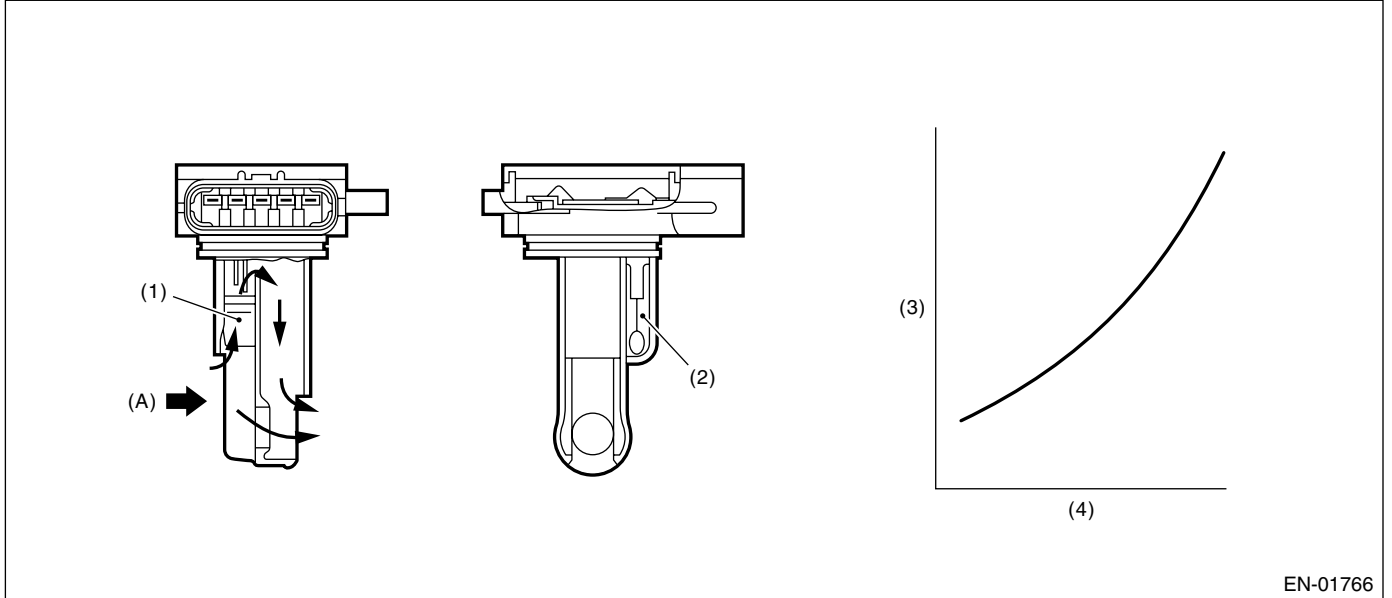

(1) Air flow sensor

(2) Intake air temperature sensor

(3) Voltage (V)

(4) Intake air volume (kg (lb)/s)

(A) Air

3. ENABLE CONDITION

Secondary Parameters	Enable Conditions
None	

4. GENERAL DRIVING CYCLE

Always perform the diagnosis continuously.

5. DIAGNOSTIC METHOD

Judge NG when the continuous time of completing the malfunction criteria below becomes more than 0.5 seconds. Judge OK and clear the NG when the malfunction criteria below are not completed.

Judgment Value

Malfunction Criteria	Threshold Value
Output voltage	≤ 0.2 V

Time Needed for Diagnosis: 0.5 seconds

Malfunction Indicator Light Illumination: Illuminates as soon as the malfunction occurs.

6. DTC CLEAR CONDITION

- When the OK idling cycle was completed 40 times in a row
- When "Clear Memory" was performed

7. MALFUNCTION INDICATOR LIGHT CLEAR CONDITION

- When the OK driving cycle was completed 3 times in a row
- When "Clear Memory" was performed

DIAGNOSTIC TROUBLE CODE (DTC) DETECTING CRITERIA

GENERAL DESCRIPTION

8. FAIL SAFE

- Air flow meter: Engine load is normally calculated by manifold pressure and engine speed; however, calculated only by manifold pressure.
- EVAP conc. learning (fuel): Not allowed to learn.
- Knock compensation:
 - Knock compensation final timing advance and retard value = knock compensation + whole learning compensation value + partial learning compensation value.
 - At normal: knock compensation = 0°CA is fixed.
 - At trouble: knock compensation ≠ 0°CA is fixed. (Retard max. 12°CA at knock.)
 - Not allowed to update the whole learning compensation factor.
 - Not allowed to calculate the partial learning zone compensation value.
- ISC control: Make the open loop compensation to be the given value (1 g (0.04 oz)/s). Stop calculating the throttle sensor temperature compensation. (Hold the previous value.)
- Purge control: Not allowed to purge.

9. ECM OPERATING AT DTC SETTING

Memorize the freeze frame data. (For test mode \$02)

DIAGNOSTIC TROUBLE CODE (DTC) DETECTING CRITERIA

GENERAL DESCRIPTION

K: DTC P0103 — MASS OR VOLUME AIR FLOW CIRCUIT HIGH INPUT —

1. OUTLINE OF DIAGNOSIS

Detect the open or short circuit of air flow sensor. Judge NG when out of the standard value.

2. COMPONENT DESCRIPTION

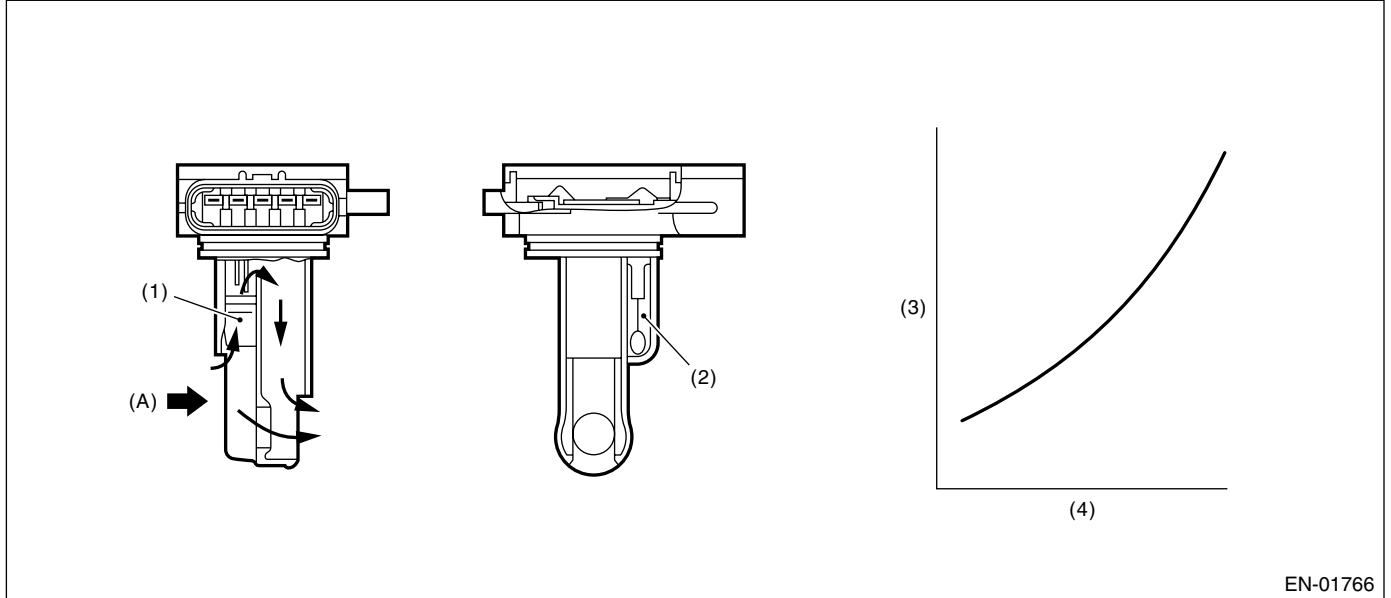

EN-01766

(1) Air flow sensor

(3) Voltage (V)

(A) Air

(2) Intake air temperature sensor

(4) Intake air volume (kg (lb)/s)

3. ENABLE CONDITION

Secondary Parameters	Enable Conditions
None	

4. GENERAL DRIVING CYCLE

Always perform the diagnosis continuously.

5. DIAGNOSTIC METHOD

Judge NG when the continuous time of completing the malfunction criteria below becomes more than 0.5 seconds. Judge OK and clear the NG when the malfunction criteria below are not completed.

Judgment Value

Malfunction Criteria	Threshold Value
Output voltage	≥ 4.985 V

Time Needed for Diagnosis: 0.5 seconds

Malfunction Indicator Light Illumination: Illuminates as soon as the malfunction occurs.

6. DTC CLEAR CONDITION

- When the OK idling cycle was completed 40 times in a row
- When "Clear Memory" was performed

7. MALFUNCTION INDICATOR LIGHT CLEAR CONDITION

- When the OK driving cycle was completed 3 times in a row
- When "Clear Memory" was performed

DIAGNOSTIC TROUBLE CODE (DTC) DETECTING CRITERIA

GENERAL DESCRIPTION

8. FAIL SAFE

- Air flow meter: Engine load is normally calculated by manifold pressure and engine speed; however, calculated only by manifold pressure.
- EVAP conc. learning (fuel): Not allowed to learn.
- Knock compensation:
 - Knock compensation final timing advance and retard value = knock compensation + whole learning compensation value + partial learning compensation value.
 - At normal: knock compensation = 0°CA is fixed.
 - At trouble: knock compensation ≠ 0°CA is fixed. (Retard max. 12°CA at knock.)
 - Not allowed to update the whole learning compensation factor.
 - Not allowed to calculate the partial learning zone compensation value.
- ISC control: Make the open loop compensation to be the given value (1 g (0.04 oz)/s). Stop calculating the throttle sensor temperature compensation. (Hold the previous value.)
- Purge control: Not allowed to purge.

9. ECM OPERATING AT DTC SETTING

Memorize the freeze frame data. (For test mode \$02)

DIAGNOSTIC TROUBLE CODE (DTC) DETECTING CRITERIA

GENERAL DESCRIPTION

L: DTC P0107 — MANIFOLD ABSOLUTE PRESSURE/BAROMETRIC PRESSURE CIRCUIT LOW INPUT —

1. OUTLINE OF DIAGNOSIS

Detect the open or short circuit of intake manifold pressure sensor. Judge NG when out of the standard value.

2. COMPONENT DESCRIPTION

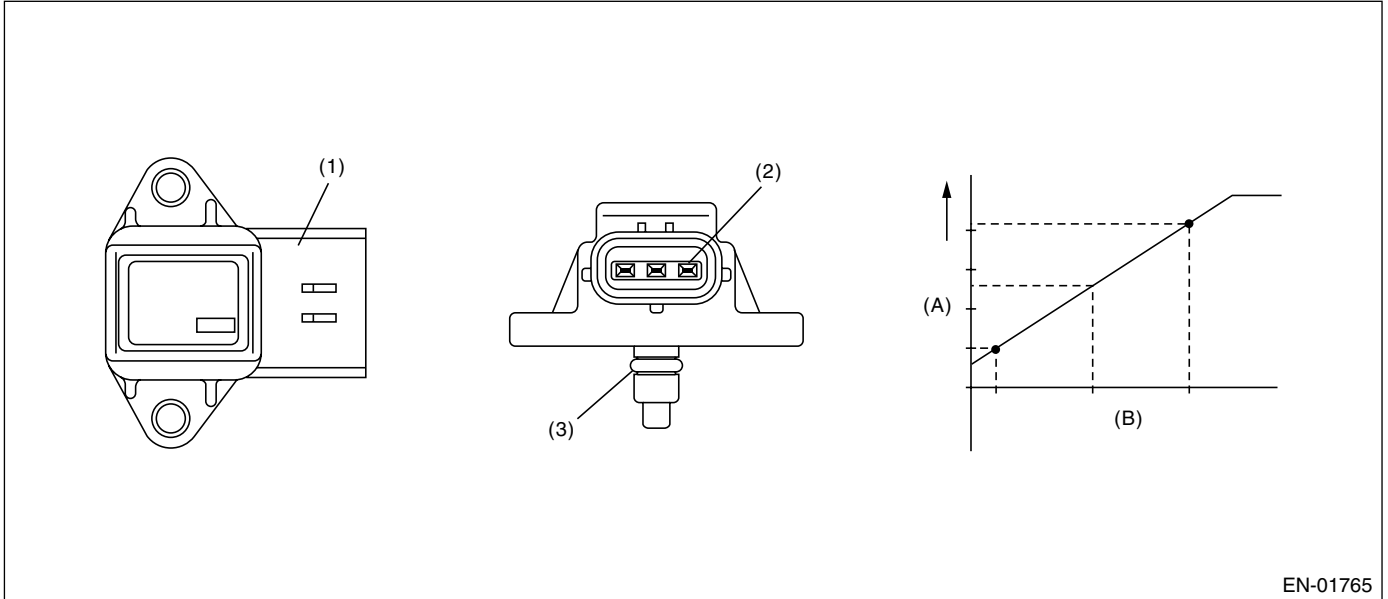

EN-01765

(1) Connector

(2) Terminal

(3) O-ring

(A) Output voltage

(B) Absolute pressure

3. ENABLE CONDITION

Secondary Parameters	Enable Conditions
Battery voltage	≥ 10.9 V

4. GENERAL DRIVING CYCLE

Always perform the diagnosis continuously.

5. DIAGNOSTIC METHOD

Judge NG when the continuous time of completing the malfunction criteria below becomes more than 0.5 seconds. Judge OK and clear the NG when the malfunction criteria below are not completed.

Judgment Value

Malfunction Criteria	Threshold Value
Output voltage	< 0.568 V

Time Needed for Diagnosis: 0.5 seconds

Malfunction Indicator Light Illumination: Illuminates as soon as the malfunction occurs.

6. DTC CLEAR CONDITION

- When the OK idling cycle was completed 40 times in a row
- When "Clear Memory" was performed

7. MALFUNCTION INDICATOR LIGHT CLEAR CONDITION

- When the OK driving cycle was completed 3 times in a row
- When "Clear Memory" was performed

DIAGNOSTIC TROUBLE CODE (DTC) DETECTING CRITERIA

GENERAL DESCRIPTION

8. FAIL SAFE

- Intake manifold pressure sensor process: Estimate the pressure from engine load.
- ISC feedback: Not allowed to calculate the amount of feedback.
- Heavy fuel judgment: Not allowed to carry out the heavy judgment.
- Fuel cut control: Not allowed to cut the over pressure charged fuel.

9. ECM OPERATING AT DTC SETTING

Memorize the freeze frame data. (For test mode \$02)

DIAGNOSTIC TROUBLE CODE (DTC) DETECTING CRITERIA

GENERAL DESCRIPTION

M: DTC P0108 — MANIFOLD ABSOLUTE PRESSURE/BAROMETRIC PRESSURE CIRCUIT HIGH INPUT —

1. OUTLINE OF DIAGNOSIS

Detect the open or short circuit of intake manifold pressure sensor. Judge NG when out of the standard value.

2. COMPONENT DESCRIPTION

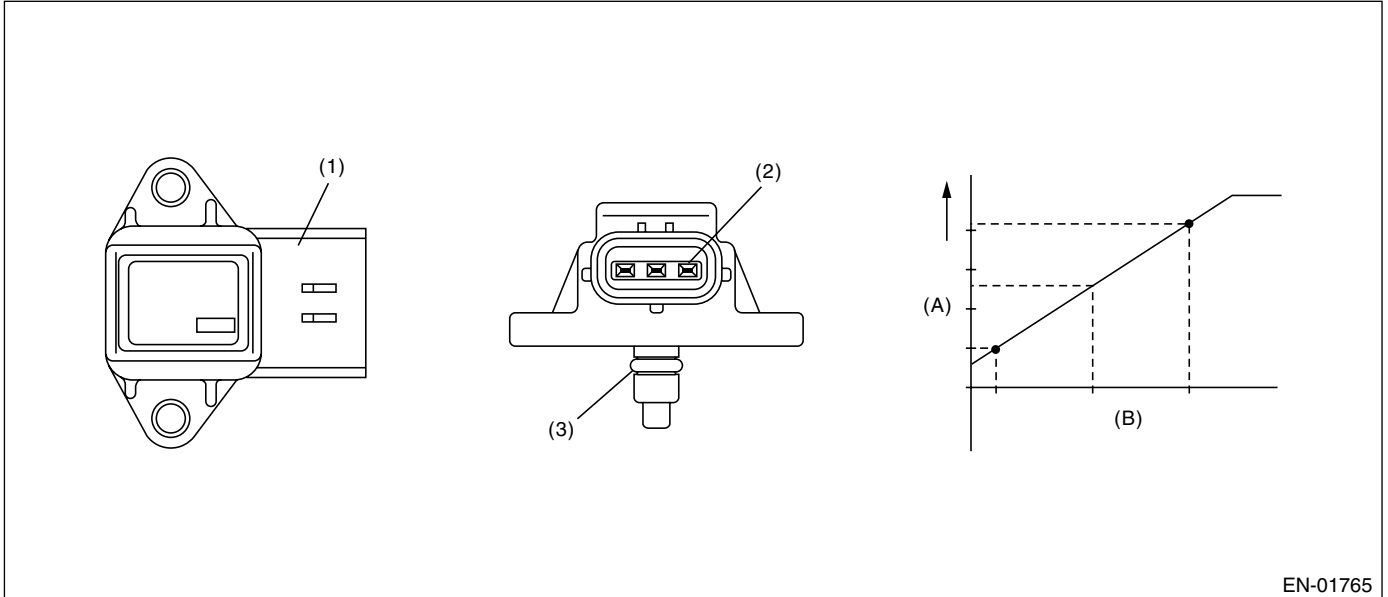

EN-01765

(1) Connector

(2) Terminal

(3) O-ring

(A) Output voltage

(B) Absolute pressure

3. ENABLE CONDITION

Secondary Parameters	Enable Conditions
Battery voltage	≥ 10.9 V

4. GENERAL DRIVING CYCLE

Always perform the diagnosis continuously.

5. DIAGNOSTIC METHOD

Judge NG when the continuous time of completing the malfunction criteria below becomes more than 0.5 seconds. Judge OK and clear the NG when the malfunction criteria below are not completed.

Judgment Value

Malfunction Criteria	Threshold Value
Output voltage	≥ 4.93 V

Time Needed for Diagnosis: 0.5 seconds

Malfunction Indicator Light Illumination: Illuminates as soon as the malfunction occurs.

6. DTC CLEAR CONDITION

- When the OK idling cycle was completed 40 times in a row
- When "Clear Memory" was performed

7. MALFUNCTION INDICATOR LIGHT CLEAR CONDITION

- When the OK driving cycle was completed 3 times in a row
- When "Clear Memory" was performed

DIAGNOSTIC TROUBLE CODE (DTC) DETECTING CRITERIA

GENERAL DESCRIPTION

8. FAIL SAFE

- Intake manifold pressure sensor process: Estimate the pressure from engine load.
- ISC feedback: Not allowed to calculate the amount of feedback.
- Heavy fuel judgment: Not allowed to carry out the heavy judgment.
- Fuel cut control: Not allowed to cut the over pressure charged fuel.

9. ECM OPERATING AT DTC SETTING

Memorize the freeze frame data. (For test mode \$02)

DIAGNOSTIC TROUBLE CODE (DTC) DETECTING CRITERIA

GENERAL DESCRIPTION

N: DTC P0111 — INTAKE AIR TEMPERATURE CIRCUIT RANGE/PERFORMANCE —

1. OUTLINE OF DIAGNOSIS

Detect the malfunction of intake air temperature sensor output property. Judge NG when the intake air temperature is not varied whereas it seemed to be varied from the viewpoint of engine condition.

2. COMPONENT DESCRIPTION

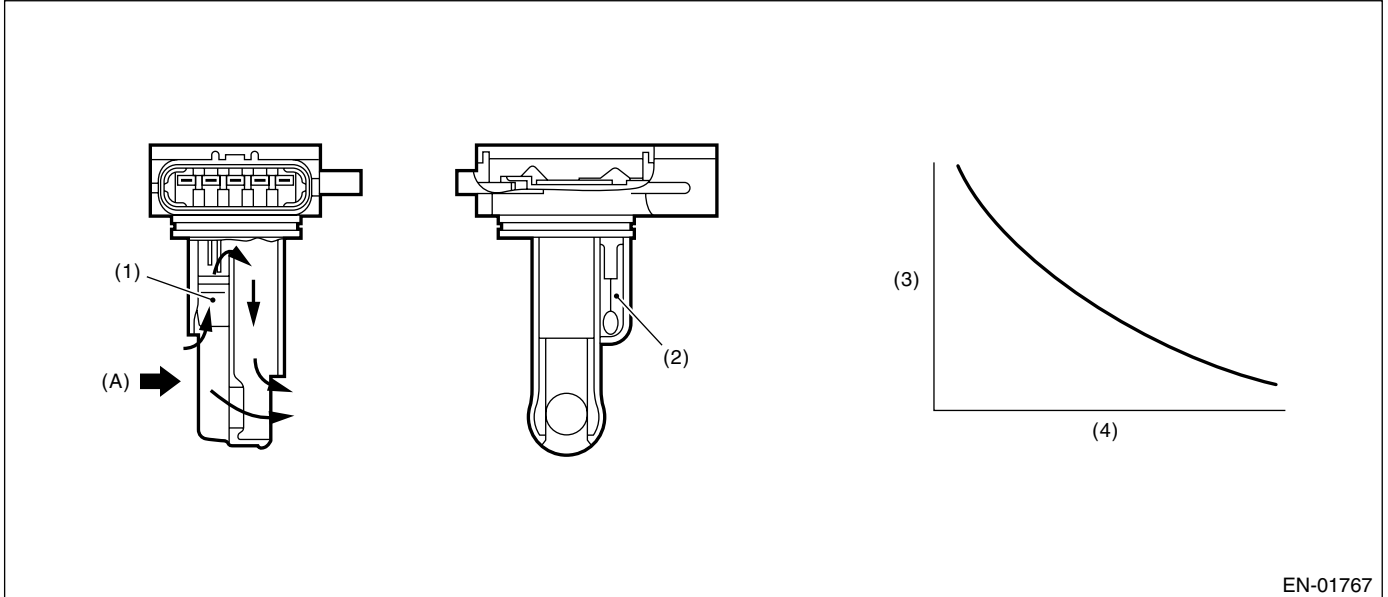

EN-01767

(1) Air flow sensor

(2) Intake air temperature sensor

(3) Resistance (Ω)

(4) Intake air temperature $^{\circ}\text{C}$ ($^{\circ}\text{F}$)

(A) Air

3. ENABLE CONDITION

Secondary Parameters	Enable Conditions
Coolant temp. before engine start	$< 30^{\circ}\text{C}$ (86°F)
Coolant temperature	$> 75^{\circ}\text{C}$ (167°F)
Battery voltage	$\geq 10.9\text{ V}$
Continuous time when the vehicle speed is less than 50 km/h (31 MPH)	600 seconds or more

4. GENERAL DRIVING CYCLE

Perform the diagnosis when the vehicle speed condition is completed after idling from starting the cooled engine.

DIAGNOSTIC TROUBLE CODE (DTC) DETECTING CRITERIA

GENERAL DESCRIPTION

5. DIAGNOSTIC METHOD

• Abnormality Judgment

Judge NG when the continuous time of completing the malfunction criteria below becomes more than 1 second.

• Judgment Value

Malfunction Criteria	Threshold Value
Output voltage difference between Max. and Min.	< 20 mV (It is equal to approx. 0.5°C (33°F) around 25°.)
Exhaust temperature above 500°C (932°F)	60 seconds or more

Time Needed for Diagnosis: 1 second

Malfunction Indicator Light Illumination: Illuminates when malfunction occurs in 2 continuous driving cycles.

• Normality Judgment

Judge OK and clear the NG when the malfunction criteria below are completed.

• Judgment Value

Malfunction Criteria	Threshold Value
Output voltage difference between Max. and Min.	≥ 20 mV

6. DTC CLEAR CONDITION

- When the OK idling cycle was completed 40 times in a row
- When "Clear Memory" was performed

7. MALFUNCTION INDICATOR LIGHT CLEAR CONDITION

- When the OK driving cycle was completed 3 times in a row
- When "Clear Memory" was performed

8. FAIL SAFE

Intake air temperature sensor process: Intake air temperature is fixed at 20°C (68°F).

9. ECM OPERATING AT DTC SETTING

Memorize the freeze frame data. (For test mode \$02)

DIAGNOSTIC TROUBLE CODE (DTC) DETECTING CRITERIA

GENERAL DESCRIPTION

O: DTC P0112 — INTAKE AIR TEMPERATURE CIRCUIT LOW INPUT —

1. OUTLINE OF DIAGNOSIS

Detect the open or short circuit of intake air temperature sensor. Judge NG when out of the standard value.

2. COMPONENT DESCRIPTION

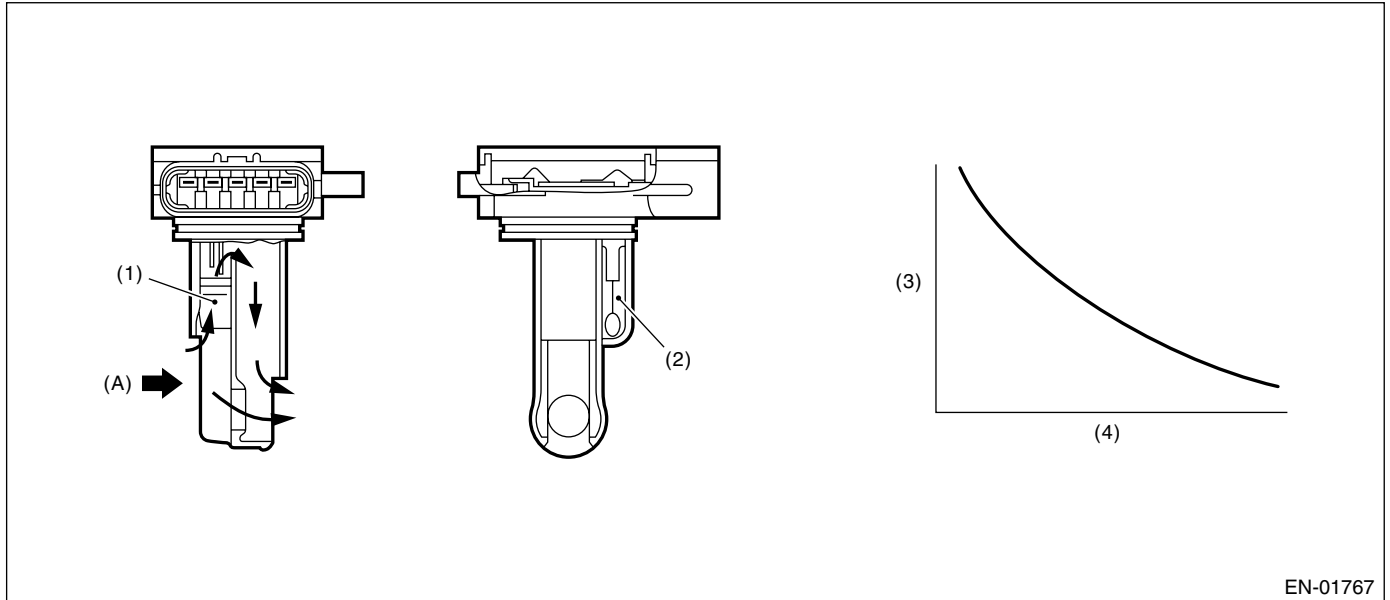

EN-01767

(1) Air flow sensor

(3) Resistance (Ω)

(A) Air

(2) Intake air temperature sensor

(4) Intake air temperature $^{\circ}\text{C}$ ($^{\circ}\text{F}$)

3. ENABLE CONDITION

Secondary Parameters	Enable Conditions
None	

4. GENERAL DRIVING CYCLE

Always perform the diagnosis continuously.

DIAGNOSTIC TROUBLE CODE (DTC) DETECTING CRITERIA

GENERAL DESCRIPTION

5. DIAGNOSTIC METHOD

• Abnormality Judgment

Judge NG when the continuous time of completing the malfunction criteria below becomes more than 0.5 seconds.

• Judgment Value

Malfunction Criteria	Threshold Value
Output voltage	< 0.165 V
Ignition switch	ON

Time Needed for Diagnosis: 0.5 seconds

Malfunction Indicator Light Illumination: Illuminates as soon as the malfunction occurs.

• Normality Judgment

Judge OK and clear the NG when the malfunction criteria below are completed.

• Judgment Value

Malfunction Criteria	Threshold Value
Output voltage	≥ 0.165 V
Ignition switch	ON

6. DTC CLEAR CONDITION

- When the OK idling cycle was completed 40 times in a row
- When "Clear Memory" was performed

7. MALFUNCTION INDICATOR LIGHT CLEAR CONDITION

- When the OK driving cycle was completed 3 times in a row
- When "Clear Memory" was performed

8. FAIL SAFE

Intake air temperature sensor process: Intake air temperature is fixed at 20°C (68°F).

9. ECM OPERATING AT DTC SETTING

Memorize the freeze frame data. (For test mode \$02)

DIAGNOSTIC TROUBLE CODE (DTC) DETECTING CRITERIA

GENERAL DESCRIPTION

P: DTC P0113 — INTAKE AIR TEMPERATURE CIRCUIT HIGH INPUT —

1. OUTLINE OF DIAGNOSIS

Detect the open or short circuit of intake air temperature sensor. Judge NG when out of the standard value.

2. COMPONENT DESCRIPTION

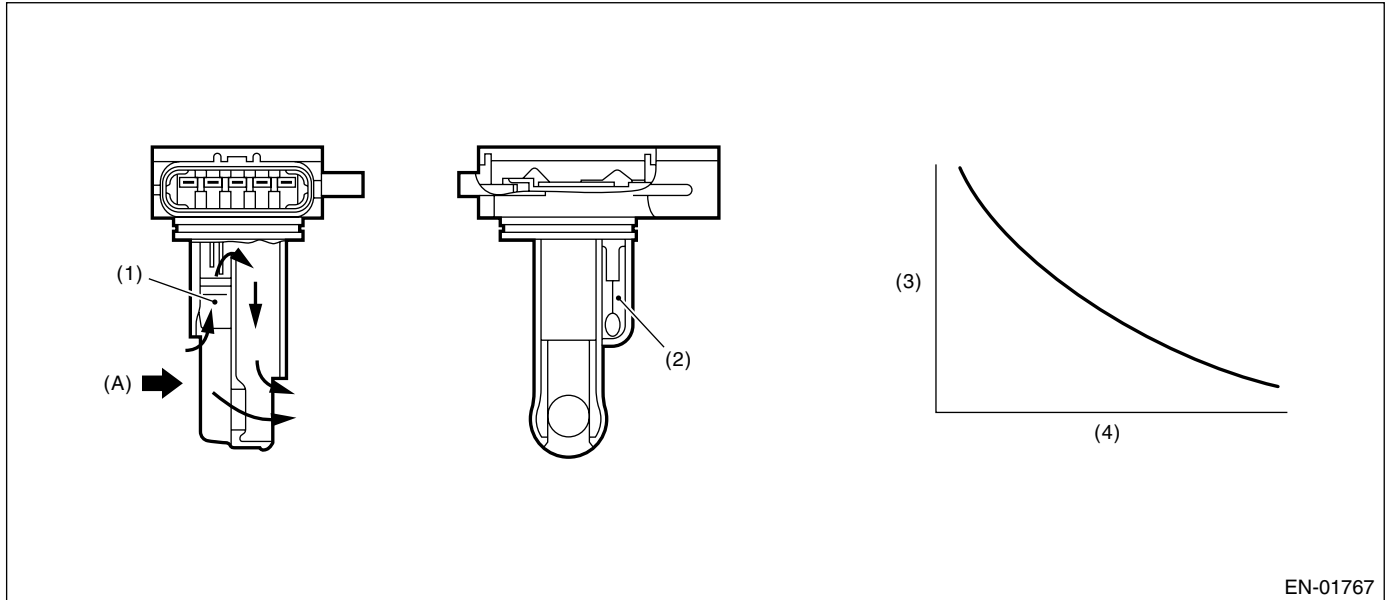

(1) Air flow sensor

(3) Resistance (Ω)

(A) Air

(2) Intake air temperature sensor

(4) Intake air temperature $^{\circ}\text{C}$ ($^{\circ}\text{F}$)

3. ENABLE CONDITION

Secondary Parameters	Enable Conditions
None	

4. GENERAL DRIVING CYCLE

Always perform the diagnosis continuously.

DIAGNOSTIC TROUBLE CODE (DTC) DETECTING CRITERIA

GENERAL DESCRIPTION

5. DIAGNOSTIC METHOD

• Abnormality Judgment

Judge NG when the continuous time of completing the malfunction criteria below becomes more than 0.5 seconds.

• Judgment Value

Malfunction Criteria	Threshold Value
Output voltage	≥ 4.72 V
Ignition switch	ON

Time Needed for Diagnosis: 0.5 seconds

Malfunction Indicator Light Illumination: Illuminates as soon as the malfunction occurs.

• Normality Judgment

Judge OK and clear the NG when the malfunction criteria below are completed.

• Judgment Value

Malfunction Criteria	Threshold Value
Output voltage	≥ 0.23 V
Ignition switch	ON

6. DTC CLEAR CONDITION

- When the OK idling cycle was completed 40 times in a row
- When "Clear Memory" was performed

7. MALFUNCTION INDICATOR LIGHT CLEAR CONDITION

- When the OK driving cycle was completed 3 times in a row
- When "Clear Memory" was performed

8. FAIL SAFE

Intake air temperature sensor process: Intake air temperature is fixed at 20°C (68°F).

9. ECM OPERATING AT DTC SETTING

Memorize the freeze frame data. (For test mode \$02)

DIAGNOSTIC TROUBLE CODE (DTC) DETECTING CRITERIA

GENERAL DESCRIPTION

Q: DTC P0117 — ENGINE COOLANT TEMPERATURE CIRCUIT LOW INPUT —

1. OUTLINE OF DIAGNOSIS

Detect the open or short circuit of engine coolant temperature sensor. Judge NG when out of the standard value.

2. COMPONENT DESCRIPTION

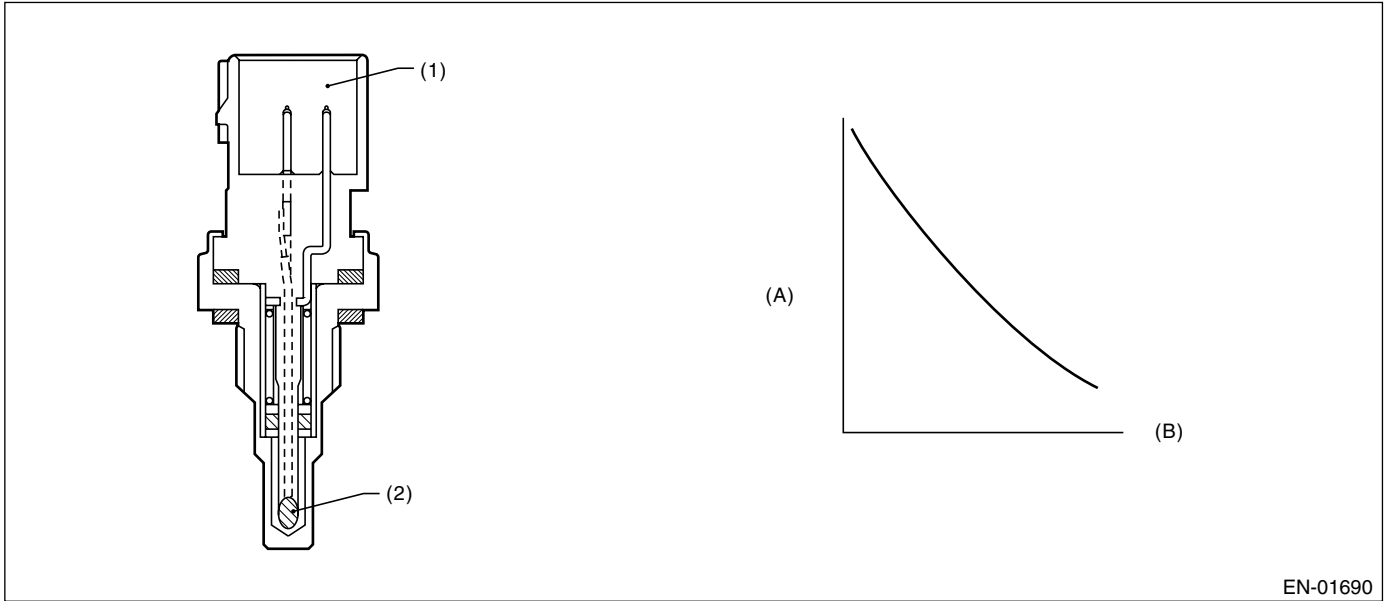

EN-01690

- (1) Connector
(2) Thermistor element
(A) Resistance value (k Ω)
(B) Temperature °C (°F)

3. ENABLE CONDITION

Secondary Parameters	Enable Conditions
None	

4. GENERAL DRIVING CYCLE

Always perform the diagnosis continuously.

5. DIAGNOSTIC METHOD

Judge NG when the continuous time of completing the malfunction criteria below becomes more than 0.5 seconds. Judge OK and clear the NG when the malfunction criteria below are not completed.

Judgment Value

Malfunction Criteria	Threshold Value
Output voltage	< 0.165 V

Time Needed for Diagnosis: 0.5 seconds

Malfunction Indicator Light Illumination: Illuminates as soon as the malfunction occurs.

6. DTC CLEAR CONDITION

- When the OK idling cycle was completed 40 times in a row
- When "Clear Memory" was performed

7. MALFUNCTION INDICATOR LIGHT CLEAR CONDITION

- When the OK driving cycle was completed 3 times in a row
- When "Clear Memory" was performed

DIAGNOSTIC TROUBLE CODE (DTC) DETECTING CRITERIA

GENERAL DESCRIPTION

8. FAIL SAFE

- Engine coolant temperature process: Fix the engine coolant temperature at 70°C (158°F).
- ISC feedback: Calculate the target engine speed setting the engine coolant temperature to 70°C (158°F).
- ISC learning: Not allowed to learn.
- Heavy fuel judgment control: Not allowed to carry out the heavy judgment.
- Air conditioner control: Not allowed to turn the air conditioner to ON.
- Radiator fan control: Both main and sub fan are in High driving.
- Increase compensation factor at high coolant temperature: Increase normally occurs with high temperature and other conditions; however, occurs with other conditions except coolant temperature condition.
- AVCS control: Make the oil flow control valve driving output to be Duty=0%.
- Tumble generator valve control: Open the tumble generator valve.

9. ECM OPERATING AT DTC SETTING

Memorize the freeze frame data. (For test mode \$02)

DIAGNOSTIC TROUBLE CODE (DTC) DETECTING CRITERIA

GENERAL DESCRIPTION

R: DTC P0118 — ENGINE COOLANT TEMPERATURE CIRCUIT HIGH INPUT —

1. OUTLINE OF DIAGNOSIS

Detect the open or short circuit of engine coolant temperature sensor. Judge NG when out of the standard value.

2. COMPONENT DESCRIPTION

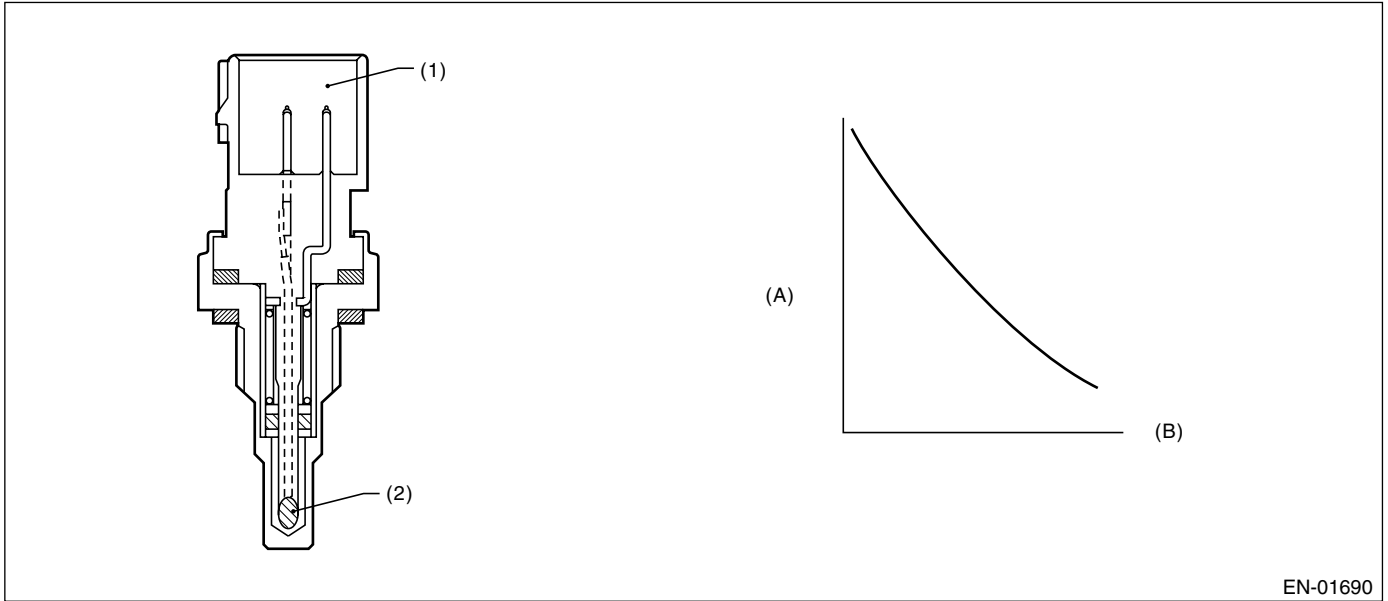

EN-01690

(1) Connector

(2) Thermistor element

(A) Resistance value (k Ω)

(B) Temperature °C (°F)

3. ENABLE CONDITION

Secondary Parameters	Enable Conditions
None	

4. GENERAL DRIVING CYCLE

Always perform the diagnosis continuously.

5. DIAGNOSTIC METHOD

Judge NG when the continuous time of completing the malfunction criteria below becomes more than 0.5 seconds. Judge OK and clear the NG when the malfunction criteria below are not completed.

Judgment Value

Malfunction Criteria	Threshold Value
Output voltage	≥ 4.72 V

Time Needed for Diagnosis: 0.5 seconds

Malfunction Indicator Light Illumination: Illuminates as soon as the malfunction occurs.

6. DTC CLEAR CONDITION

- When the OK idling cycle was completed 40 times in a row
- When "Clear Memory" was performed

7. MALFUNCTION INDICATOR LIGHT CLEAR CONDITION

- When the OK driving cycle was completed 3 times in a row
- When "Clear Memory" was performed

DIAGNOSTIC TROUBLE CODE (DTC) DETECTING CRITERIA

GENERAL DESCRIPTION

8. FAIL SAFE

- Engine coolant temperature process: Fix the engine coolant temperature at 70°C (158°F).
- ISC feedback: Calculate the target engine speed setting the engine coolant temperature to 70°C (158°F).
- ISC learning: Not allowed to learn.
- Heavy fuel judgment control: Not allowed to carry out the heavy judgment.
- Air conditioner control: Not allowed to turn the air conditioner to ON.
- Radiator fan control: Both main and sub fan are in High driving.
- Increase compensation factor at high coolant temperature: Increase normally occurs with high temperature and other conditions; however, occurs with other conditions except coolant temperature condition.
- AVCS control: Make the oil flow control valve driving output to be Duty=0%.
- Tumble generator valve control: Open the tumble generator valve.

9. ECM OPERATING AT DTC SETTING

Memorize the freeze frame data. (For test mode \$02)

DIAGNOSTIC TROUBLE CODE (DTC) DETECTING CRITERIA

GENERAL DESCRIPTION

8. FAIL SAFE

Stop power distribution to electric control throttle motor. (Throttle opening is fixed to 6°.)

9. ECM OPERATION AT DTC SETTING

Memorize the freeze frame data. (For test mode \$02)

DIAGNOSTIC TROUBLE CODE (DTC) DETECTING CRITERIA

GENERAL DESCRIPTION

T: DTC P0123 — THROTTLE/PEDAL POSITION SENSOR/SWITCH “A” CIRCUIT HIGH INPUT —

1. OUTLINE OF DIAGNOSIS

Detect the open or short circuit of throttle position sensor 1.
Judge NG when out of the standard value.

2. COMPONENT DESCRIPTION

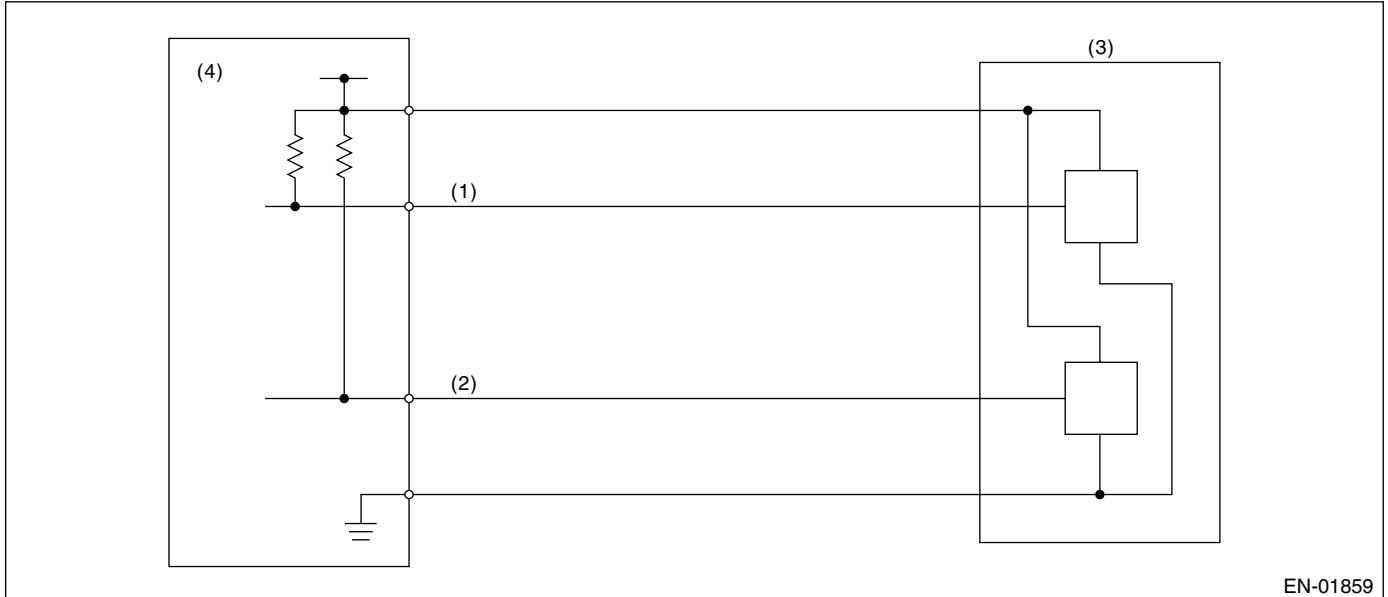

- (1) Throttle position sensor 1 signal (3) Throttle position sensor
(2) Throttle position sensor 2 signal (4) Engine control module (ECM)

3. ENABLE CONDITION

Secondary Parameters	Enable Conditions
Ignition switch	ON

4. GENERAL DRIVING CYCLE

Always perform the diagnosis continuously.

5. DIAGNOSTIC METHOD

Judge OK and clear the NG when the malfunction criteria below are completed.

Judgment Value

Malfunction Criteria	Threshold Value
Sensor 1 input voltage	≥ 4.646 V

Time Needed for Diagnosis: 24 milliseconds

Malfunction Indicator Light Illumination: Illuminates as soon as malfunction occurs.

6. DTC CLEAR CONDITION

- When the OK idling cycle was completed 40 times in a row
- When “Clear Memory” was performed (Only engine stop)

7. MALFUNCTION INDICATOR LIGHT CLEAR CONDITION

- When the OK driving cycle was completed 3 times in a row
- When “Clear Memory” was performed (Only engine stop)

DIAGNOSTIC TROUBLE CODE (DTC) DETECTING CRITERIA

GENERAL DESCRIPTION

8. FAIL SAFE

Stop power distribution to electric control throttle motor. (Throttle opening is fixed to 6°.)

9. ECM OPERATION AT DTC SETTING

Memorize the freeze frame data. (For test mode \$02)

DIAGNOSTIC TROUBLE CODE (DTC) DETECTING CRITERIA

GENERAL DESCRIPTION

U: DTC P0125 — INSUFFICIENT COOLANT TEMPERATURE FOR CLOSED LOOP FUEL CONTROL —

1. OUTLINE OF DIAGNOSIS

Detect the malfunction of engine coolant temperature output property. Judge NG when the engine coolant temperature does not rise whereas it seemed to rise from the viewpoint of the engine condition.

2. COMPONENT DESCRIPTION

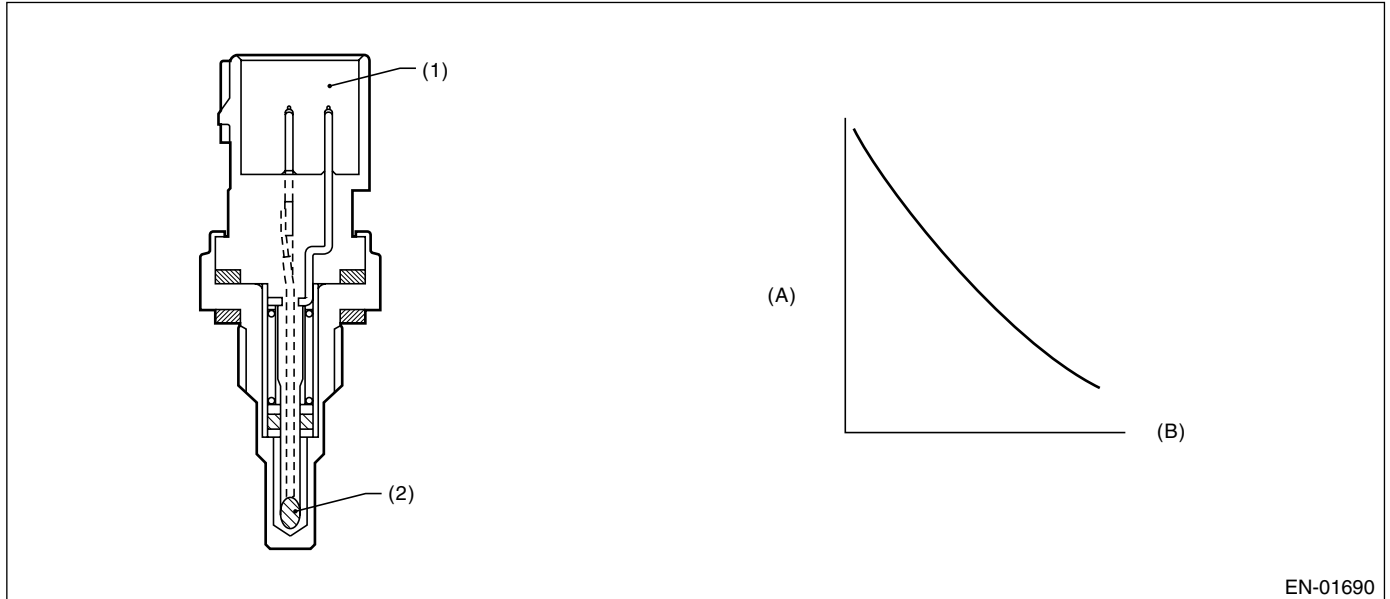

(1) Connector

(2) Thermistor element

(A) Resistance value (k Ω)

(B) Temperature °C (°F)

3. ENABLE CONDITION

Secondary Parameters	Enable Conditions
Engine speed	≥ 500 rpm
Battery voltage	> 10.9 V

4. GENERAL DRIVING CYCLE

Perform the diagnosis only once after engine starting.

DIAGNOSTIC TROUBLE CODE (DTC) DETECTING CRITERIA

GENERAL DESCRIPTION

5. DIAGNOSTIC METHOD

• Abnormality Judgment

Judge NG when the malfunction criteria below are completed.

• Judgment Value

Malfunction Criteria	Threshold Value
Engine coolant temperature	< 20°C (68°F)
Timer for diagnosis after engine starting	≥ Timer judgment value after engine starting

Timer for diagnosis after engine starting

a) Timer stop at fuel cut mode.

b) During the driving conditions except a) above, timer count up by 64 milliseconds + TWCNT milliseconds at every 64 milliseconds.

Where, TWCNT is determined as follows,

TWCNT = 0 at idle switch ON,

TWCNT show on the following table at idle switch OFF.

Temperature °C (°F)	Vehicle speed km/h (MPH)							
	0 (0)	8 (4.97)	16 (9.94)	24 (14.9)	32 (19.9)	40 (24.9)	48 (29.8)	56 (34.8)
-20 (-4)	0 ms	37.14 ms	74.27 ms	111.41 ms	126.66 ms	141.91 ms	163.59 ms	185.26 ms
-10 (14)	0 ms	27.39 ms	54.78 ms	82.17 ms	99.65 ms	117.13 ms	135.96 ms	154.80 ms
0 (32)	0 ms	17.65 ms	35.29 ms	52.94 ms	72.64 ms	92.34 ms	108.34 ms	124.33 ms
10 (50)	0 ms	7.90 ms	15.80 ms	23.70 ms	45.63 ms	67.56 ms	80.71 ms	93.87 ms
20 (68)	0 ms	7.90 ms	15.80 ms	23.70 ms	45.63 ms	67.56 ms	80.71 ms	93.87 ms

Judgment value of timer after engine starting

$$t = 451.1 - 25.9 \times T_i$$

T_i is the lowest coolant temperature after starting the engine.

Time Needed for Diagnosis: To be determined. (It is varied by the Min. engine coolant temperature and engine conditions such as vehicle speed and engine coolant temperature.)

Malfunction Indicator Light Illumination: Illuminates when malfunction occurs in 2 continuous driving cycles.

• Normality Judgment

Judge OK and clear the NG when the malfunction criteria below are completed.

• Judgment Value

Malfunction Criteria	Threshold Value
Engine coolant temperature	≥ 20°C (68°F)

6. DTC CLEAR CONDITION

- When the OK idling cycle was completed 40 times in a row
- When "Clear Memory" was performed

7. MALFUNCTION INDICATOR LIGHT CLEAR CONDITION

- When the OK driving cycle was completed 3 times in a row
- When "Clear Memory" was performed

DIAGNOSTIC TROUBLE CODE (DTC) DETECTING CRITERIA

GENERAL DESCRIPTION

8. FAIL SAFE

- Engine coolant temperature process: Fix the engine coolant temperature at 70°C (158°F).
- ISC feedback: Calculate the target engine speed setting the engine coolant temperature to 70°C (158°F).
- ISC learning: Not allowed to learn.
- Heavy fuel judgment control: Not allowed to carry out the heavy judgment.
- Air conditioner control: Not allowed to turn the air conditioner to ON.
- Radiator fan control: Both main and sub fan are in High driving.
- Increase compensation factor at high coolant temperature: Increase normally occurs with high temperature and other conditions; however, occurs with other conditions except coolant temperature condition.
- AVCS control: Make the oil flow control valve driving output to be Duty=0%.
- Tumble generator valve control: Open the tumble generator valve.

9. ECM OPERATING AT DTC SETTING

Memorize the freeze frame data. (For test mode \$02)

DIAGNOSTIC TROUBLE CODE (DTC) DETECTING CRITERIA

GENERAL DESCRIPTION

MEMO:

DIAGNOSTIC TROUBLE CODE (DTC) DETECTING CRITERIA

GENERAL DESCRIPTION

V: DTC P0128 — COOLANT THERMOSTAT (COOLANT TEMPERATURE BELOW THERMOSTAT REGULATING TEMPERATURE) —

1. OUTLINE OF DIAGNOSIS

Detect the malfunction of thermostat function. Judge NG when the engine coolant temperature is lower than the estimated engine coolant temperature and the difference between them is large. Judge OK when the engine coolant temperature becomes 75°C (167°F) and the difference is small before judging NG.

2. COMPONENT DESCRIPTION

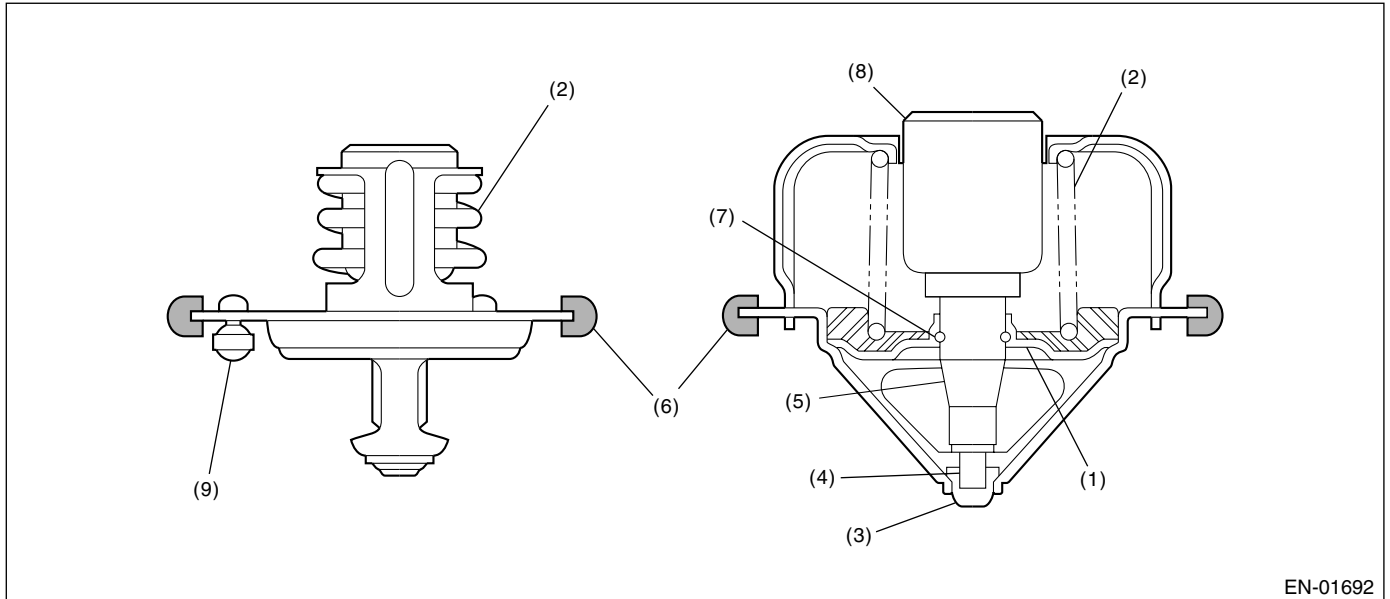

- | | | |
|-------------|--------------------|------------------|
| (1) Valve | (4) Piston | (7) Stop ring |
| (2) Spring | (5) Guide | (8) Wax element |
| (3) Stopper | (6) Rubber packing | (9) Jiggle valve |

3. ENABLE CONDITION

Secondary Parameters	Enable Conditions
None	

4. GENERAL DRIVING CYCLE

Always perform the diagnosis continuously.

DIAGNOSTIC TROUBLE CODE (DTC) DETECTING CRITERIA

GENERAL DESCRIPTION

5. DIAGNOSTIC METHOD

• Abnormality Judgment

Judge NG when the continuous time of completing the malfunction criteria below becomes more than 30 seconds.

• Judgment Value

Malfunction Criteria	Threshold Value
Battery voltage	≥ 10.9 V
Estimated ambient air temperature	$\geq -7^{\circ}\text{C}$ (19.4°F)
Engine coolant temperature at engine starting	$< 55^{\circ}\text{C}$ (131°F)
Estimated coolant temperature	$\geq 75^{\circ}\text{C}$ (167°F)
Engine coolant temperature	$< 75^{\circ}\text{C}$ (167°F)
(Estimated – measured) coolant temperature	$> 30^{\circ}\text{C}$ (86°F)

Time Needed for Diagnosis: 30 seconds

Malfunction Indicator Light Illumination: Illuminates when malfunction occurs in 2 continuous driving cycles.

• Normality Judgment

Judge OK and clear the NG when the malfunction criteria below are completed.

• Judgment Value

Malfunction Criteria	Threshold Value
Battery voltage	≥ 10.9 V
Estimated ambient air temperature	$\geq -7^{\circ}\text{C}$ (19.4°F)
Thermostat malfunction diagnosis	Not finished
Engine coolant temperature at engine starting	$< 55^{\circ}\text{C}$ (131°F)
Engine coolant temperature	$\geq 75^{\circ}\text{C}$ (167°F)
(Estimated – measured) coolant temperature	$\leq 30^{\circ}\text{C}$ (86°F)

6. DTC CLEAR CONDITION

- When the OK idling cycle was completed 40 times in a row
- When “Clear Memory” was performed

7. MALFUNCTION INDICATOR LIGHT CLEAR CONDITION

- When the OK driving cycle was completed 3 times in a row
- When “Clear Memory” was performed

8. FAIL SAFE

None

9. ECM OPERATING AT DTC SETTING

- Memorize the freeze frame data. (For test mode \$02)
- Memorize the diagnostic value and trouble standard value. (For test mode \$06)

DIAGNOSTIC TROUBLE CODE (DTC) DETECTING CRITERIA

GENERAL DESCRIPTION

W: DTC P0129 — BAROMETRIC PRESSURE TOO LOW —

1. OUTLINE OF DIAGNOSIS

Detect the malfunction of atmospheric pressure sensor output property. Judge NG when the atmospheric pressure sensor output is largely different from the intake manifold pressure at engine starting.

2. COMPONENT DESCRIPTION

Atmospheric pressure sensor is built in ECM.

3. ENABLE CONDITION

Secondary Parameters	Enable Conditions
Engine speed	< 300 rpm
Vehicle speed	< 1 km/h (0.62 MPH)

4. GENERAL DRIVING CYCLE

Perform the diagnosis once before engine starting with the ignition switch ON.

5. DIAGNOSTIC METHOD

• Abnormality Judgment

Judge NG when the continuous time of completing the malfunction criteria below becomes more than 0.3 seconds.

• Judgment Value

Malfunction Criteria	Threshold Value
Atmospheric – manifold absolute pressure	≥ 26.7 kPa (200 mmHg, 7.88 inHg)
Intake manifold pressure at engine starting – manifold absolute pressure	< 1.33 kPa (10 mmHg, 2.95 inHg)

Time Needed for Diagnosis: 0.3 seconds

Malfunction Indicator Light Illumination: Detect when malfunction occurs in 2 continuous driving cycles.

• Normality Judgment

Judge OK and clear the NG when the continuous time of completing the malfunction criteria below becomes more than 0.26 seconds.

• Judgment Value

Malfunction Criteria	Threshold Value
Atmospheric – manifold absolute pressure	< 26.7 kPa (200 mmHg, 7.88 inHg)

6. DTC CLEAR CONDITION

- When the OK idling cycle was completed 40 times in a row
- When “Clear Memory” was performed

7. MALFUNCTION INDICATOR LIGHT CLEAR CONDITION

- When the OK driving cycle was completed 3 times in a row
- When “Clear Memory” was performed

8. FAIL SAFE

Atmospheric pressure sensor process: Fix the atmospheric pressure to 101 kPa (760 mmHg, 29.8 inHg).

9. ECM OPERATING AT DTC SETTING

Memorize the freeze frame data. (For test mode \$02)

DIAGNOSTIC TROUBLE CODE (DTC) DETECTING CRITERIA

GENERAL DESCRIPTION

MEMO:

DIAGNOSTIC TROUBLE CODE (DTC) DETECTING CRITERIA

GENERAL DESCRIPTION

X: DTC P0131 — O₂ SENSOR CIRCUIT LOW VOLTAGE (BANK 1 SENSOR 1) —

1. OUTLINE OF DIAGNOSIS

Detect the open or short circuit of sensor.

Judge NG when the element impressed voltage is out of range, or the element current is out of range.

2. COMPONENT DESCRIPTION

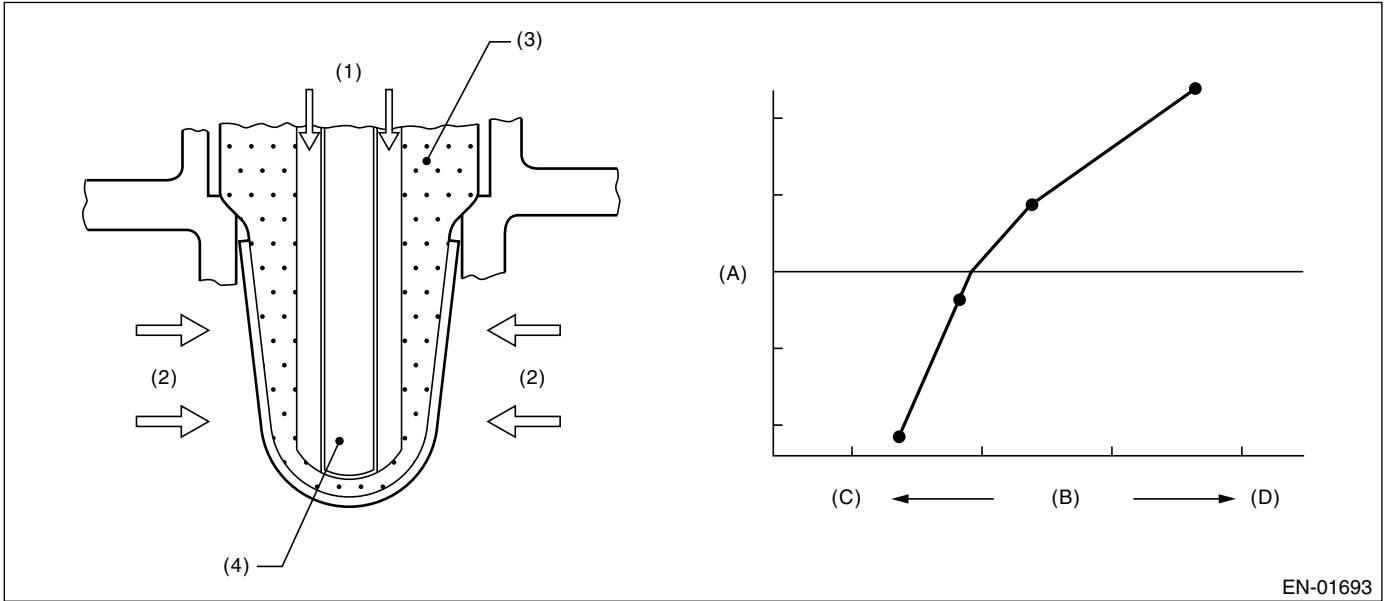

EN-01693

- | | |
|----------------------|-------------------------|
| (1) Atmosphere | (A) Electromotive force |
| (2) Exhaust | (B) Air fuel ratio |
| (3) ZrO ₂ | (C) Lean |
| (4) Ceramic heater | (D) Rich |

3. ENABLE CONDITION

Secondary Parameters	Enable Conditions
Voltage	≥ 10.9 V

4. GENERAL DRIVING CYCLE

Always perform the diagnosis continuously.

5. DIAGNOSTIC METHOD

Judge NG when the continuous time of completing any malfunction criteria below becomes more than 1 second.

Judgment Value

Malfunction Criteria	Threshold Value
Input voltage	< 1.8 V
Input current	< -0.01 A

Time Needed for Diagnosis: 1 second

Malfunction Indicator Light Illumination: Illuminates as soon as the malfunction occurs.

6. DTC CLEAR CONDITION

- When the OK idling cycle was completed 40 times in a row
- When "Clear Memory" was performed

DIAGNOSTIC TROUBLE CODE (DTC) DETECTING CRITERIA

GENERAL DESCRIPTION

7. MALFUNCTION INDICATOR LIGHT CLEAR CONDITION

- When the OK driving cycle was completed 3 times in a row
- When "Clear Memory" was performed

8. FAIL SAFE

- Front oxygen (A/F) sensor activation judgment: Front oxygen (A/F) sensor full activation is not complete, or front oxygen (A/F) sensor half activation is not complete.
- A/F main learning: Not allowed to calculate the A/F main learning compensation factor.
- Compensation when starting the engine at high temperature: Make the MIN value to be 0 from 0.3 normally.
- Purge control: Not allowed to purge.

9. ECM OPERATING AT DTC SETTING

Memorize the freeze frame data. (For test mode \$02)

DIAGNOSTIC TROUBLE CODE (DTC) DETECTING CRITERIA

GENERAL DESCRIPTION

Y: DTC P0132 — O₂ SENSOR CIRCUIT HIGH VOLTAGE (BANK 1 SENSOR 1) —

1. OUTLINE OF DIAGNOSIS

Detect the open or short circuit of sensor.

Judge NG when the element impressed voltage is out of range, or the element current is out of range.

2. COMPONENT DESCRIPTION

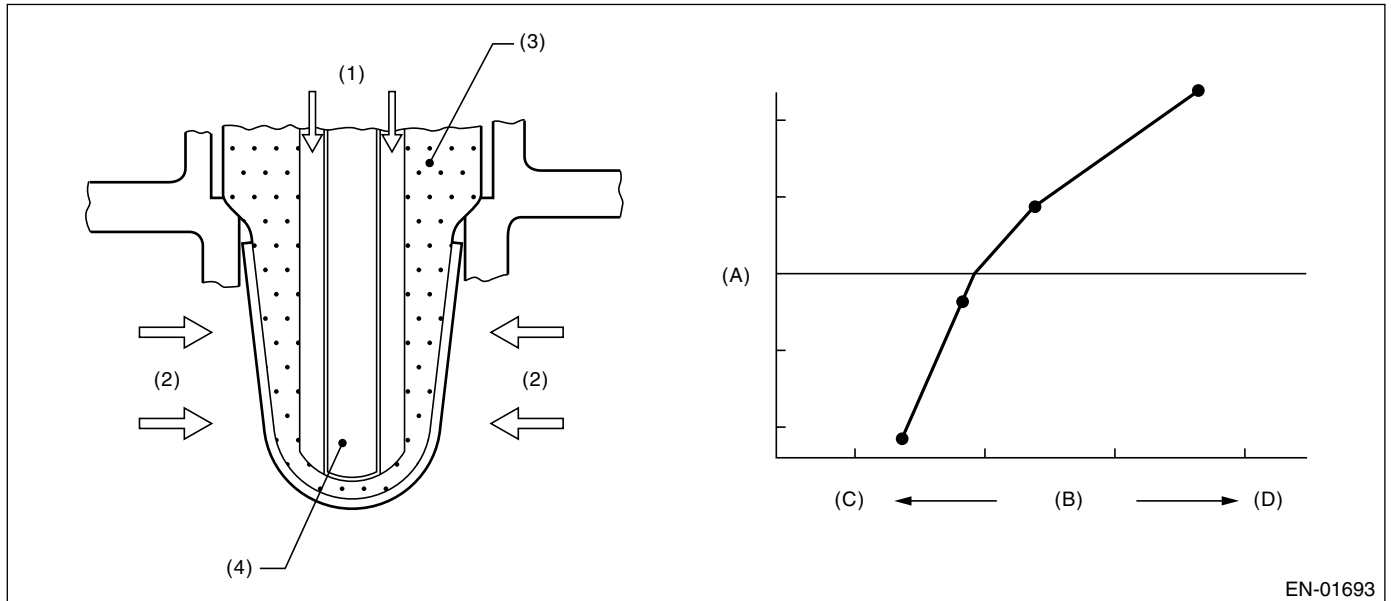

EN-01693

- | | |
|----------------------|-------------------------|
| (1) Atmosphere | (A) Electromotive force |
| (2) Exhaust | (B) Air fuel ratio |
| (3) ZrO ₂ | (C) Lean |
| (4) Ceramic heater | (D) Rich |

3. ENABLE CONDITION

Secondary Parameters	Enable Conditions
Voltage	≥ 10.9 V

4. GENERAL DRIVING CYCLE

Always perform the diagnosis continuously.

5. DIAGNOSTIC METHOD

Judge NG when the continuous time of completing any malfunction criteria below becomes more than 1 second.

Judgment Value

Malfunction Criteria	Threshold Value
Input voltage	≥ 3.8 V
Input current	≥ 0.01 A

Time Needed for Diagnosis: 1 second

Malfunction Indicator Light Illumination: Illuminates as soon as the malfunction occurs.

6. DTC CLEAR CONDITION

- When the OK idling cycle was completed 40 times in a row
- When "Clear Memory" was performed

DIAGNOSTIC TROUBLE CODE (DTC) DETECTING CRITERIA

GENERAL DESCRIPTION

7. MALFUNCTION INDICATOR LIGHT CLEAR CONDITION

- When the OK driving cycle was completed 3 times in a row
- When "Clear Memory" was performed

8. FAIL SAFE

- Front oxygen (A/F) sensor activation judgment: Front oxygen (A/F) sensor full activation is not complete, or front oxygen (A/F) sensor half activation is not complete.
- A/F main learning: Not allowed to calculate the A/F main learning compensation factor.
- Compensation when starting the engine at high temperature: Make the MIN value to be 0 from 0.3 normally.
- Purge control: Not allowed to purge.

9. ECM OPERATING AT DTC SETTING

Memorize the freeze frame data. (For test mode \$02)

DIAGNOSTIC TROUBLE CODE (DTC) DETECTING CRITERIA

GENERAL DESCRIPTION

Z: DTC P0133 — O₂ SENSOR CIRCUIT SLOW RESPONSE (BANK 1 SENSOR 1)

1. OUTLINE OF DIAGNOSIS

Detect time-lag of front oxygen (A/F) sensor response. Front oxygen (A/F) sensor cover has some ventilation holes for exhaust gas. Clogged ventilation holes are diagnosed. When the holes are clogged, the A/F output variation becomes slow comparing with the actual A/F variation because oxygen which reaches the zirconia layer is insufficient. Therefore, if the cover has clogged holes, the rich to lean judgment in ECM is delayed when the change from rich to lean is caused.

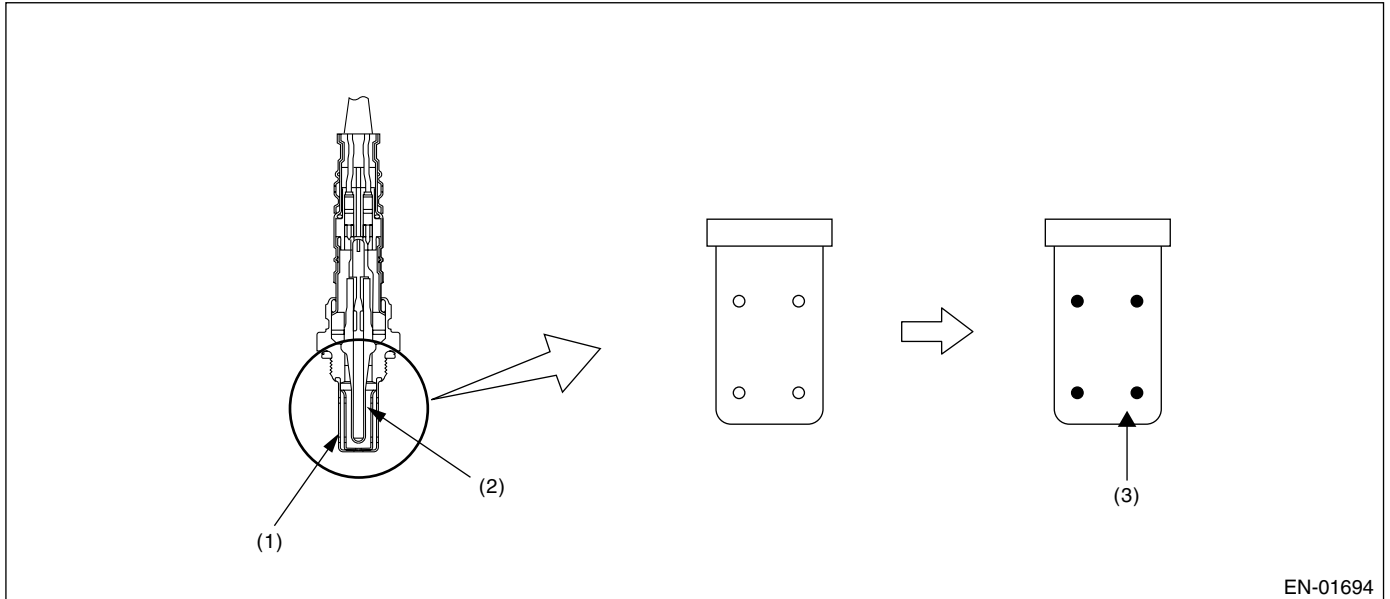

(1) Cover

(2) Zirconia

(3) Clogging

DIAGNOSTIC TROUBLE CODE (DTC) DETECTING CRITERIA

GENERAL DESCRIPTION

2. COMPONENT DESCRIPTION

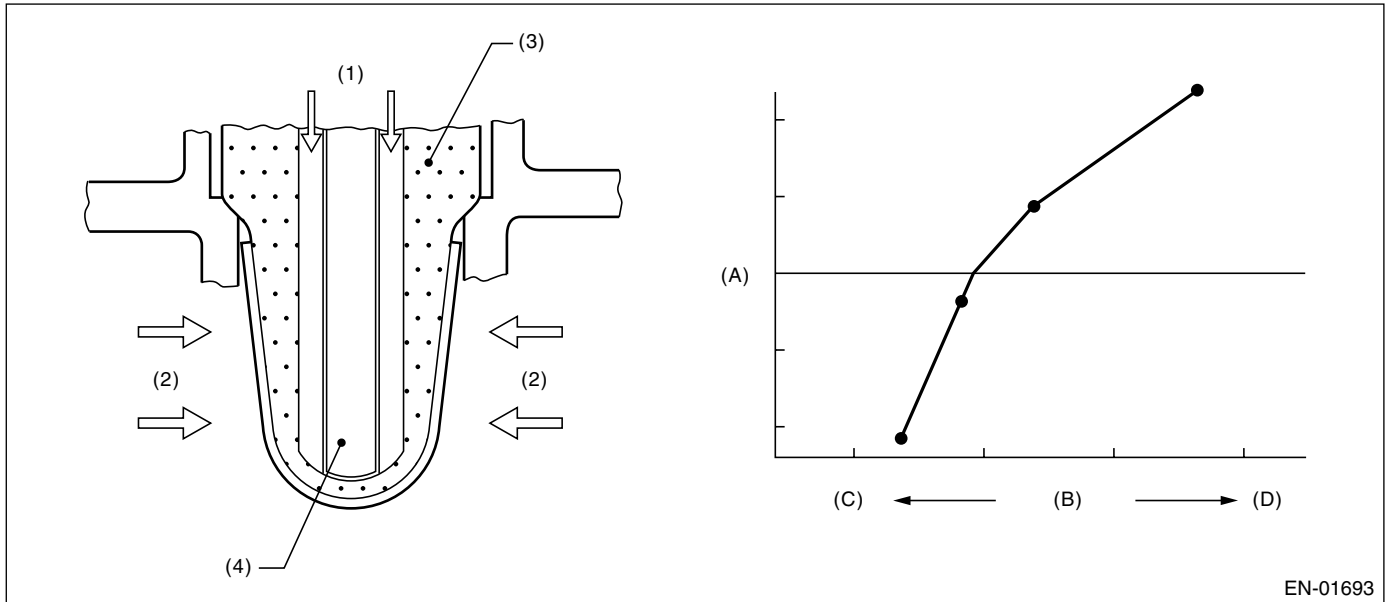

EN-01693

- | | |
|----------------------|-------------------------|
| (1) Atmosphere | (A) Electromotive force |
| (2) Exhaust | (B) Air fuel ratio |
| (3) ZrO ₂ | (C) Lean |
| (4) Ceramic heater | (D) Rich |

3. ENABLE CONDITION

Secondary Parameters	Enable Conditions
All secondary parameter enable conditions	more than 1 second
Battery voltage	> 10.9 V
Atmospheric pressure	> 75.1 kPa (563 mmHg, 22.2 inHg)
Closed loop control with main feedback operating	operating
Impedance of front oxygen (A/F) sensor	0 ↔ 50 Ω
After starting engine	120 seconds or more
Engine coolant temperature	≥ 75°C (167°F)
Engine speed	1000 ↔ 3200 rpm
Vehicle speed	10 ↔ 120 km/h (6.21 ↔ 74.6 MPH)
Amount of intake air	10 ↔ 31 g (0.35 ↔ 1.09 oz)/s
Engine load change during 0.5 engine rev.	≤ 0.02 g (0.001 oz)/rev
All conditions for EVAP canister purge	to be in enable
Learning value of EVAP conc. during purge	≤ 0.2
Total time of operating canister purge	20 seconds or more

4. GENERAL DRIVING CYCLE

Perform diagnosis only once at a constant speed of 10 to 120 km/h (6.21 to 74.6 MPH) in 120 seconds after starting the engine.

DIAGNOSTIC TROUBLE CODE (DTC) DETECTING CRITERIA

GENERAL DESCRIPTION

5. DIAGNOSTIC METHOD

Integrate the difference of f_{af} in every 128 milliseconds and difference of λ value.

After integrate 1640 times (210 seconds), calculate the diagnosis value.

Judge NG when the malfunction criteria below are completed. Judge OK and clear NG when the malfunction criteria below are not completed.

Judgment Value

Malfunction Criteria	Threshold Value
$para_{fca} = td2f_{af}/td2l_{md}$ where, $td2f_{af}(N) = td2f_{af}(n-1) + d2f_{af}(n) $ $td2l_{md}(N) = td2l_{md}(n-1) + d2l_{md}(n) $ add up for a total of 210 seconds $d2f_{af}(n) = (f_{af}(n) - f_{af}(n-1)) - (f_{af}(n-1) - f_{af}(n-2))$ $d2l_{md}(n) = (l_{md}(n) - l_{md}(n-1)) - (l_{md}(n-1) - l_{md}(n-2))$ f_{af} = main feedback compensation coefficient every 128 milliseconds l_{md} = output lambda every 128 milliseconds	≥ 0.367

Time Needed for Diagnosis: 210 seconds

Malfunction Indicator Light Illumination: Illuminates when malfunction occurs in 2 continuous driving cycles.

6. DTC CLEAR CONDITION

- When the OK idling cycle was completed 40 times in a row
- When "Clear Memory" was performed

7. MALFUNCTION INDICATOR LIGHT CLEAR CONDITION

- When the OK driving cycle was completed 3 times in a row
- When "Clear Memory" was performed

8. FAIL SAFE

- Front oxygen (A/F) sensor main learning correction: Not allowed to calculate.
- Correction when re-starting at high temperature: Normally minimum value $0.3 \rightarrow 0$.
- Purge control: Not allowed to purge.

9. ECM OPERATING AT DTC SETTING

- Memorize the freeze frame data. (For test mode \$02)
- Memorize the diagnostic value and trouble standard value. (For test mode \$06)

DIAGNOSTIC TROUBLE CODE (DTC) DETECTING CRITERIA

GENERAL DESCRIPTION

MEMO:

DIAGNOSTIC TROUBLE CODE (DTC) DETECTING CRITERIA

GENERAL DESCRIPTION

AA:DTC P0134 — O₂ SENSOR CIRCUIT NO ACTIVITY DETECTED (BANK 1 SENSOR 1) —

1. OUTLINE OF DIAGNOSIS

Detect the open circuit of sensor.
Judge NG when the element impedance is large.

2. COMPONENT DESCRIPTION

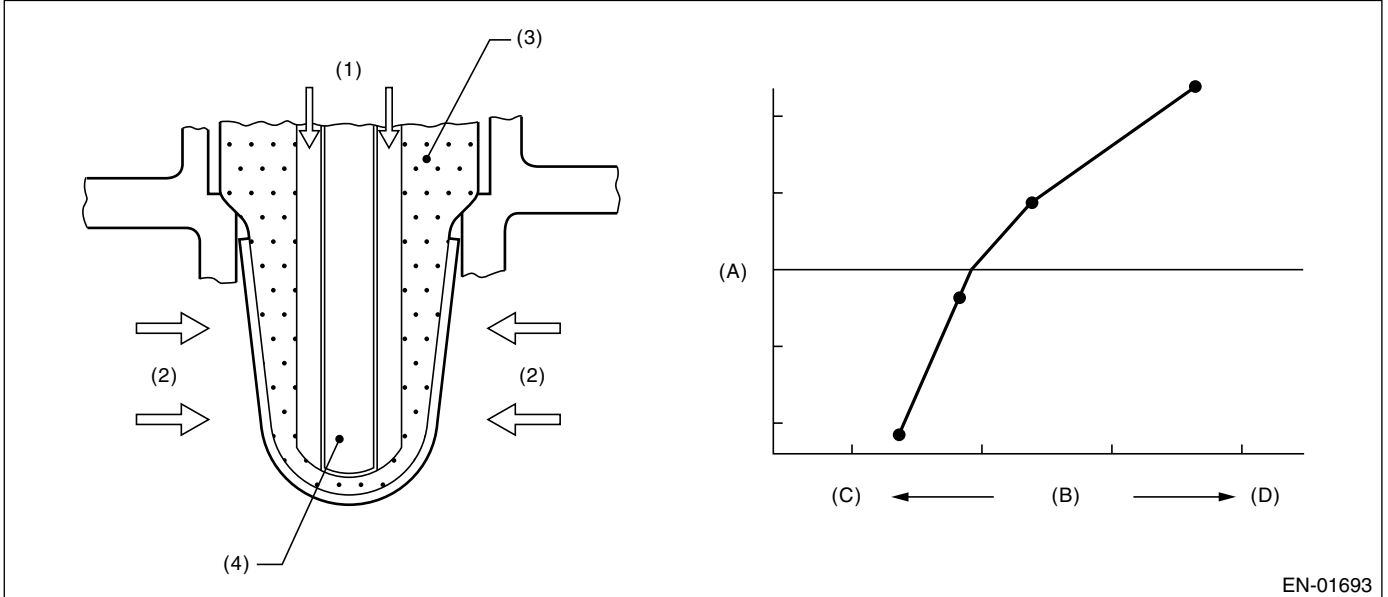

EN-01693

- | | |
|----------------------|-------------------------|
| (1) Atmosphere | (A) Electromotive force |
| (2) Exhaust | (B) Air fuel ratio |
| (3) ZrO ₂ | (C) Lean |
| (4) Ceramic heater | (D) Rich |

3. ENABLE CONDITION

Secondary Parameters	Enable Conditions
None	

4. GENERAL DRIVING CYCLE

Always perform the diagnosis continuously.

5. DIAGNOSTIC METHOD

Judge NG when the continuous time of completing the malfunction criteria below becomes more than 5 seconds.

Judgment Value

Malfunction Criteria	Threshold Value
Voltage	≥ 10.9 V
Time after engine starting	≥ 50 seconds
Cumulative amount of Front O ₂ (A/F) sensor heater control duty every 128 milliseconds	≥ 28000%
Front lambda sensor impedance	≥ 500 Ω

Time Needed for Diagnosis: 5 seconds

Malfunction Indicator Light Illumination: Illuminates as soon as the malfunction occurs.

DIAGNOSTIC TROUBLE CODE (DTC) DETECTING CRITERIA

GENERAL DESCRIPTION

6. DTC CLEAR CONDITION

- When the OK idling cycle was completed 40 times in a row
- When "Clear Memory" was performed

7. MALFUNCTION INDICATOR LIGHT CLEAR CONDITION

- When the OK driving cycle was completed 3 times in a row
- When "Clear Memory" was performed

8. FAIL SAFE

- Front oxygen (A/F) sensor activation judgment: Front oxygen (A/F) sensor full activation is not complete, or front oxygen (A/F) sensor half activation is not complete.
- A/F main learning: Not allowed to calculate the A/F main learning compensation factor.
- Compensation when starting the engine at high temperature: Make the MIN value to be 0 from 0.3 normally.
- Purge control: Not allowed to purge.

9. ECM OPERATING AT DTC SETTING

Memorize the freeze frame data. (For test mode \$02)

DIAGNOSTIC TROUBLE CODE (DTC) DETECTING CRITERIA

GENERAL DESCRIPTION

AB:DTC P0137 — O₂ SENSOR CIRCUIT LOW VOLTAGE (BANK 1 SENSOR 2) —

1. OUTLINE OF DIAGNOSIS

Detect the malfunction of rear oxygen sensor open or short circuit. Judge NG when the rear oxygen sensor voltage may be abnormal from rear oxygen sensor voltage value with considering the conditions such as intake air amount, engine coolant temperature, main feedback control.

2. COMPONENT DESCRIPTION

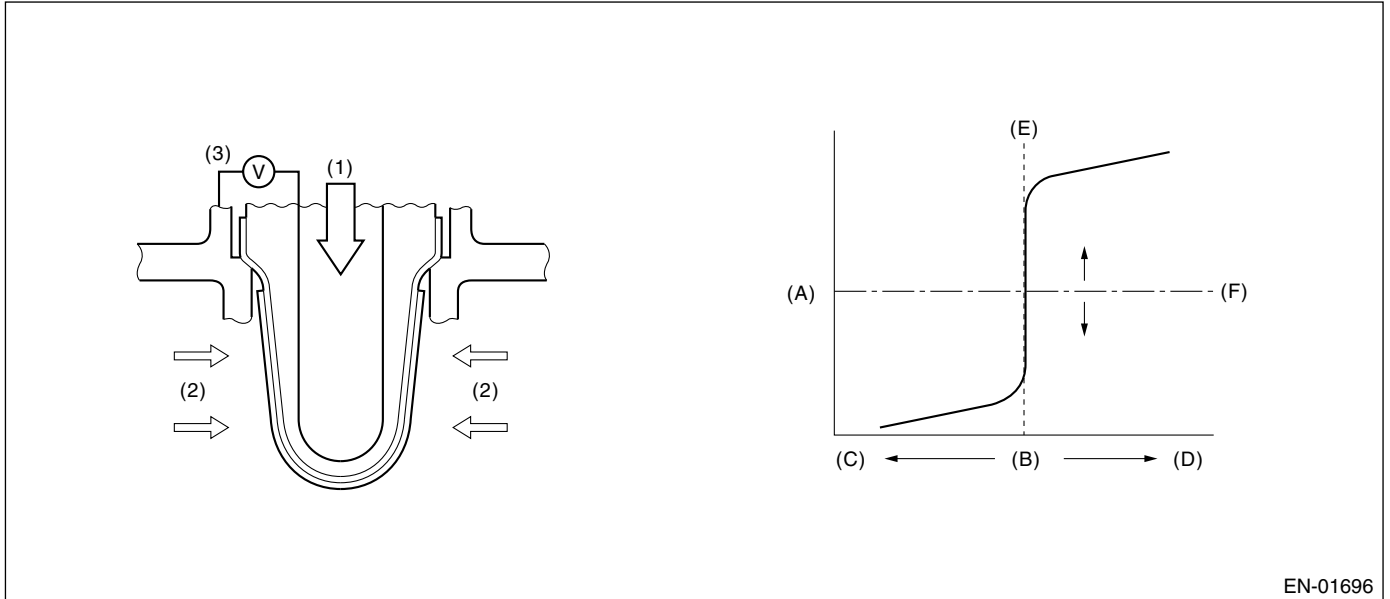

EN-01696

- (1) Atmosphere
- (2) Exhaust
- (3) Electromotive force

- (A) Electromotive force
- (B) Air fuel ratio
- (C) Rich

- (D) Lean
- (E) Theoretical air fuel ratio
- (F) Comparative voltage

3. ENABLE CONDITION (USED ONLY FOR MALFUNCTION JUDGMENT)

Secondary Parameters	Enable Conditions
Closed loop control with main feedback control	In operation
Target output voltage of rear oxygen sensor	≥ 0.54 V
Amount of intake air	≥ 10 g (0.35 oz)/s
Engine coolant temperature	≥ 75°C (167°F)
Misfire detection during 200 engine revs.	< 5 times
Compensation factor for front oxygen (A/F) sensor with main feedback control	Not in limit value
Battery voltage	> 10.9 V
Cumulative time for completing the conditions with main feedback control	≥ 200 seconds
5 seconds or more fuel shut-off in decel.	Experienced

4. GENERAL DRIVING CYCLE

Perform the diagnosis once after warming up the engine.

DIAGNOSTIC TROUBLE CODE (DTC) DETECTING CRITERIA

GENERAL DESCRIPTION

5. DIAGNOSTIC METHOD

• Abnormality Judgment

Judge NG when the malfunction criteria below are completed.

• Judgment Value

Malfunction Criteria	Threshold Value
Max. output voltage	< 490 mV

Time Needed for Diagnosis: 200 seconds

Malfunction Indicator Light Illumination: Illuminates when malfunction occurs in 2 continuous driving cycles.

• Normality Judgment

Judge OK when the malfunction criteria below are completed.

• Judgment Value

Malfunction Criteria	Threshold Value
Low side diagnosis of rear oxygen sensor voltage	Incomplete
Max. output voltage	≥ 490 mV

6. DTC CLEAR CONDITION

- When the OK idling cycle was completed 40 times in a row
- When "Clear Memory" was performed

7. MALFUNCTION INDICATOR LIGHT CLEAR CONDITION

- When the OK driving cycle was completed 3 times in a row
- When "Clear Memory" was performed

8. FAIL SAFE

Sub feedback control: Not allowed

9. ECM OPERATING AT DTC SETTING

- Memorize the freeze frame data. (For test mode \$02)
- Memorize the diagnostic value and trouble standard value. (For test mode \$06)

DIAGNOSTIC TROUBLE CODE (DTC) DETECTING CRITERIA

GENERAL DESCRIPTION

AC:DTC P0138 — O₂ SENSOR CIRCUIT HIGH VOLTAGE (BANK 1 SENSOR 2) —

1. OUTLINE OF DIAGNOSIS

Detect the malfunction of rear oxygen sensor open or short circuit. Judge NG when the rear oxygen sensor voltage may be abnormal with considering the conditions such as intake air amount, engine coolant temperature, main feedback control.

2. COMPONENT DESCRIPTION

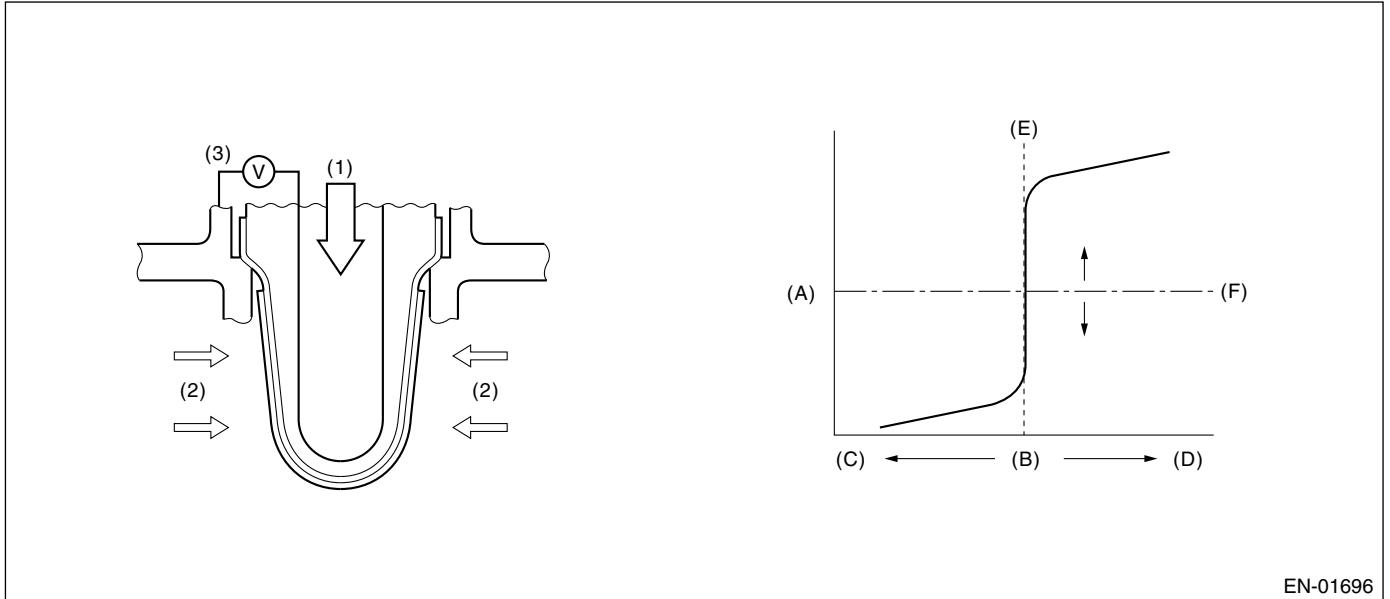

EN-01696

- (1) Atmosphere
- (2) Exhaust
- (3) Electromotive force

- (A) Electromotive force
- (B) Air fuel ratio
- (C) Rich

- (D) Lean
- (E) Theoretical air fuel ratio
- (F) Comparative voltage

3. ENABLE CONDITION (USED ONLY FOR MALFUNCTION JUDGMENT)

Secondary Parameters	Enable Conditions
Closed loop control with main feedback control	In operation
Target output voltage of rear oxygen sensor	≥ 0.54 V
Amount of intake air	≥ 10 g (0.35 oz)/s
Engine coolant temperature	≥ 75°C (167°F)
Misfire detection during 200 engine revs.	< 5 times
Compensation factor for front oxygen (A/F) sensor with main feedback control	Not in limit value
Battery voltage with main feedback control	> 10.9 V
Cumulative time for completing the conditions with main feedback control	≥ 200 seconds
5 seconds or more fuel shut-off in decel.	Experienced

4. GENERAL DRIVING CYCLE

Perform the diagnosis once after warming up the engine.

DIAGNOSTIC TROUBLE CODE (DTC) DETECTING CRITERIA

GENERAL DESCRIPTION

5. DIAGNOSTIC METHOD

• Abnormality Judgment

Judge NG when the malfunction criteria below are completed.

• Judgment Value

Malfunction Criteria	Threshold Value
Min. output voltage	> 250 mV

Time Needed for Diagnosis: 200 seconds

Malfunction Indicator Light Illumination: Detect when malfunction occurs in 2 continuous driving cycles.

• Normality Judgment

Judge OK when the malfunction criteria below are completed.

• Judgment Value

Malfunction Criteria	Threshold Value
High side diagnosis of rear oxygen sensor voltage	Incomplete
Min. output voltage	≤ 250 mV

6. DTC CLEAR CONDITION

- When the OK idling cycle was completed 40 times in a row
- When "Clear Memory" was performed

7. MALFUNCTION INDICATOR LIGHT CLEAR CONDITION

- When the OK driving cycle was completed 3 times in a row
- When "Clear Memory" was performed

8. FAIL SAFE

Sub feedback control: Not allowed

9. ECM OPERATING AT DTC SETTING

- Memorize the freeze frame data. (For test mode \$02)
- Memorize the diagnostic value and trouble standard value. (For test mode \$06)

DIAGNOSTIC TROUBLE CODE (DTC) DETECTING CRITERIA

GENERAL DESCRIPTION

AD:DTC P0139 — O₂ SENSOR CIRCUIT SLOW RESPONSE (BANK 1 SENSOR 2)

1. OUTLINE OF DIAGNOSIS

Detect the slow response of rear oxygen sensor.

• Diagnostic Method

Measure the response time of the output change of the rear oxygen sensor when the A/F ratio changes from rich to lean. And Judge NG when the measured response time is larger than the threshold value.

2. COMPONENT DESCRIPTION

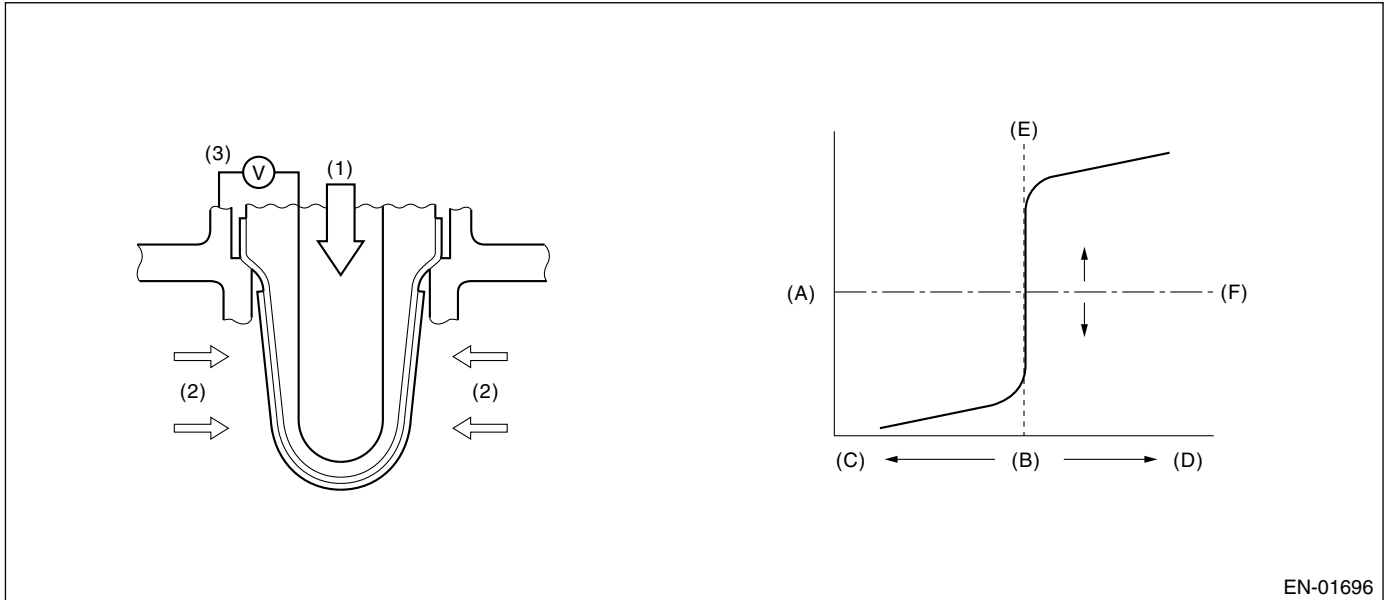

EN-01696

- (1) Atmosphere
- (2) Exhaust
- (3) Electromotive force

- (A) Electromotive force
- (B) Air fuel ratio
- (C) Rich

- (D) Lean
- (E) Theoretical air fuel ratio
- (F) Comparative voltage

3. ENABLE CONDITION

Secondary Parameters	Enable Conditions
Battery voltage	> 10.9 V
A/F main feedback control condition	Completed
5 seconds or more fuel shut-off in deceleration	Experienced
After fuel shutting-off in deceleration	2 seconds or more

4. GENERAL DRIVING CYCLE

Perform the diagnosis only once when fuel shut-off in deceleration after rapid acceleration. (Pay attention to oxygen sensor voltage for the timing of deceleration in order to calculate the diagnostic value.)

DIAGNOSTIC TROUBLE CODE (DTC) DETECTING CRITERIA

GENERAL DESCRIPTION

5. DIAGNOSTIC METHOD

When the rear oxygen sensor output voltage changes from 0.5 V (rich) to 0.2 V (lean), calculate the Min. value of response time regarded as judgment value while the output varies from 0.45 V to 0.25 V.

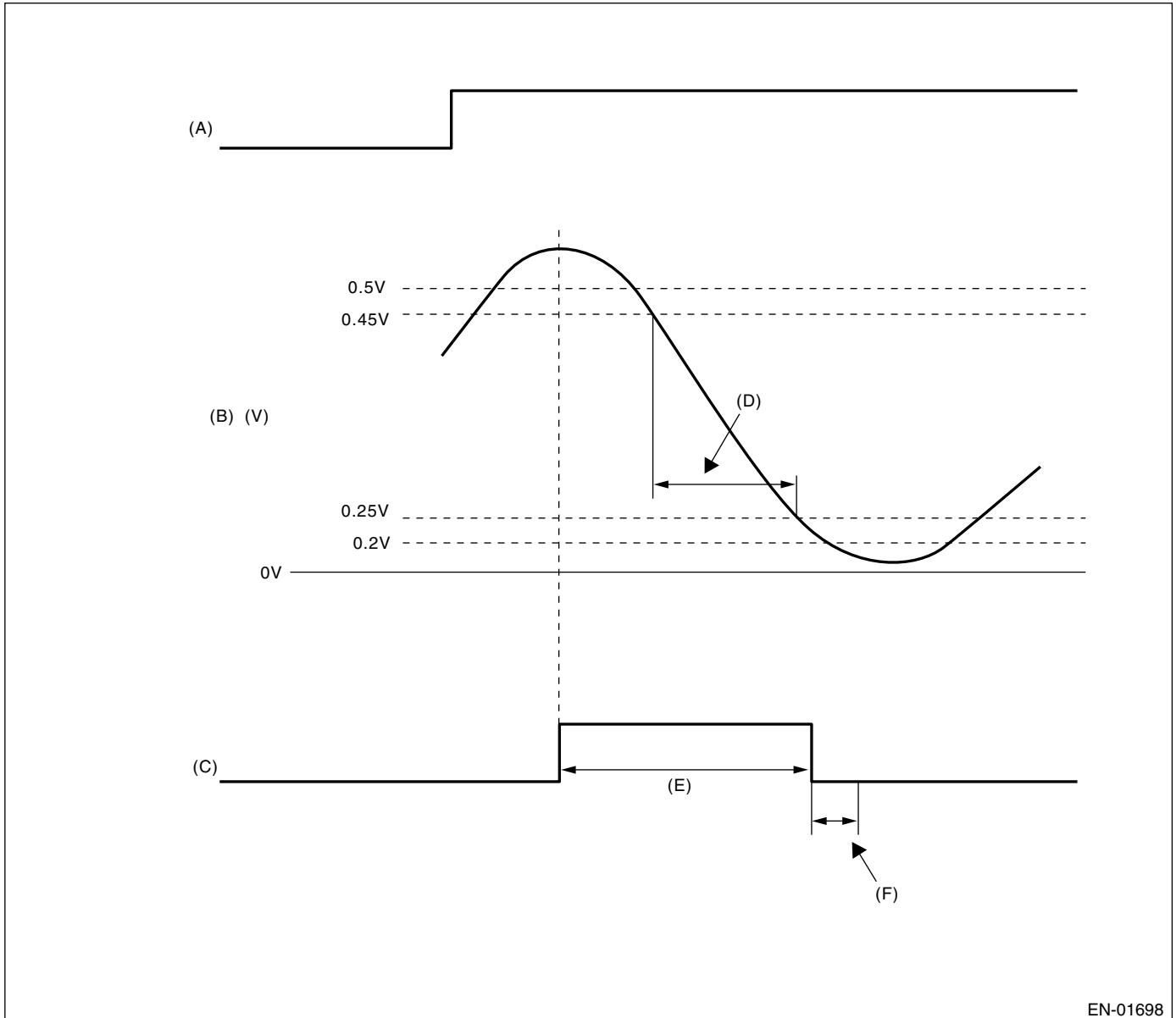

EN-01698

(A) State of diagnosis execution

(C) Fuel cut during deceleration

(E) More than 2 seconds

(B) Rear oxygen sensor

(D) Measure response time

(F) Perform malfunction determination 2 seconds after carriage return from deceleration fuel cut.

• Abnormality Judgment

Judge NG when the judgment value is larger than the threshold value after fuel shut-off in deceleration.

Response time (Diagnosis value) > Threshold value → Abnormal

Judge NG when the malfunction criteria below are completed in 2 seconds after the recovery of fuel shut-off in deceleration which requires 5 seconds or more. Judge OK when the malfunction criteria below are not completed regardless of the fuel shut-off in deceleration.

DIAGNOSTIC TROUBLE CODE (DTC) DETECTING CRITERIA

GENERAL DESCRIPTION

NOTE:

Variation time of rear oxygen sensor output voltage is short during fuel shut-off in deceleration. Carry out the NG judgment only after the fuel shut-off in deceleration. As for OK judgment, without the condition of fuel shut-off in deceleration, judge OK if the value is below the threshold value.

• Judgment Value

Malfunction Criteria	Threshold Value
Shortest time change from rich (450 mV O ₂ output) to lean (250 mV) if voltage reduces from 500 mV to 200 mV.	≥ 327 milliseconds

Time Needed for Diagnosis: 5 seconds

Malfunction Indicator Light Illumination: Illuminates when malfunction occurs in 2 continuous driving cycles.

6. DTC CLEAR CONDITION

- When the OK idling cycle was completed 40 times in a row
- When “Clear Memory” was performed

7. MALFUNCTION INDICATOR LIGHT CLEAR CONDITION

- When the OK driving cycle was completed 3 times in a row
- When “Clear Memory” was performed

8. FAIL SAFE

Sub feedback control: Not allowed

9. ECM OPERATING AT DTC SETTING

- Memorize the freeze frame data. (For test mode \$02)
- Memorize the diagnostic value and trouble standard value. (For test mode \$06)

DIAGNOSTIC TROUBLE CODE (DTC) DETECTING CRITERIA

GENERAL DESCRIPTION

MEMO:

DIAGNOSTIC TROUBLE CODE (DTC) DETECTING CRITERIA

GENERAL DESCRIPTION

AE:DTC P0171 — SYSTEM TOO LEAN (BANK 1) —

1. OUTLINE OF DIAGNOSIS

Detect the fuel system malfunction by the amount of main feedback control.

• Fuel System Diagnosis

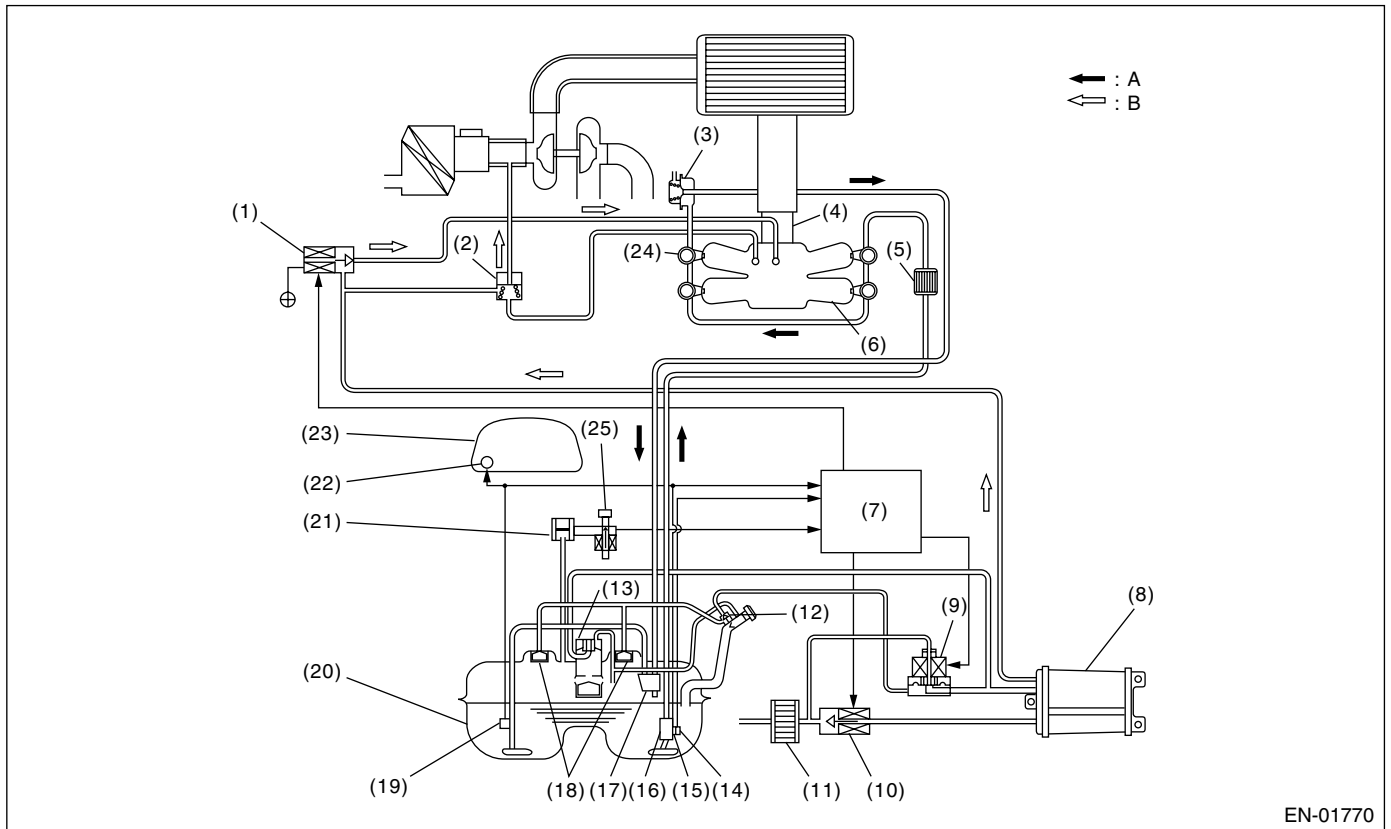

EN-01770

- | | | |
|-------------------------------------|------------------------------|---|
| (1) Purge control solenoid valve | (10) Drain valve | (19) Fuel sub level sensor |
| (2) Purge valve | (11) Drain filter | (20) Fuel tank |
| (3) Pressure regulator | (12) Shut-off valve | (21) Fuel tank pressure sensor |
| (4) Throttle body | (13) Vent valve | (22) Fuel meter |
| (5) Fuel filter | (14) Fuel temperature sensor | (23) Combination meter |
| (6) Intake manifold | (15) Fuel level sensor | (24) Fuel injector |
| (7) Engine control module (ECM) | (16) Fuel pump | (25) Tank pressure switching solenoid valve |
| (8) Canister | (17) Jet pump | |
| (9) Pressure control solenoid valve | (18) Fuel cut valve | |

• Diagnostic Method

Fuel system is diagnosed by comparing the target air fuel ratio calculated by ECM with the actual air fuel ratio measured by sensor.

DIAGNOSTIC TROUBLE CODE (DTC) DETECTING CRITERIA

GENERAL DESCRIPTION

2. ENABLE CONDITION

Secondary Parameters	Enable Conditions
A/F main learning system	In operation
Engine coolant temperature	$\geq 75\text{ }^{\circ}\text{C}$ (167°F)
Engine load	\geq Map 5
Intake air change during 0.5 engine rev.	$\leq 0.02\text{ g}$ (0.001 oz)/rev
Learning value of EVAP conc. during purge	≤ 0.1
Cumulative time of canister purge after engine start	20 seconds or more
Continuous period after canister purge starting	30 seconds or more

Map 5

Engine speed (rpm)	idle	800	1200	1600	2000	2400	2800	3200	3600	4000	4400
Measured value (g (oz)/rev)	NA	0.236 (0.008)	0.232 (0.008)	0.226 (0.008)	0.231 (0.008)	0.252 (0.009)	0.262 (0.009)	0.243 (0.009)	0.243 (0.009)	0.267 (0.009)	0.270 (0.010)

3. GENERAL DRIVING CYCLE

Perform the diagnosis continuously at idling or a constant speed after warming up the engine.

4. DIAGNOSTIC METHOD

• Abnormality Judgment

Judge that the fuel system malfunction occurs when the time during completing the malfunction criteria below continues 30 seconds or more by comparing the diagnosed value (fsobd) with threshold value.

• Judgment Value

Malfunction Criteria	Threshold Value
$\text{fsobd} = (\text{sglmd} - \text{tglm da}) + \text{faf} + \text{flaf}$ where, sglmd = measured lambda tglm da = target lambda faf = main feedback compensation coefficient every 64 milliseconds flaf = main feedback learning compensation coefficient	$\geq \text{fsobdL1}$ See Map 4 fsobdL1 = lean side threshold value of fsobd

Map 4 Threshold value for fuel system malfunction criteria

Amount of air (g (oz)/s)	0 (0)	2.4 (0.085)	4.7 (0.166)	7 (0.247)	9.4 (0.332)	11.7 (0.413)	14.1 (0.497)
fsobdL1 (%)	40	40	36.9	32.0	27.0	26.5	26.5

Time Needed for Diagnosis: 10 seconds \times 3 times

Malfunction Indicator Light Illumination: Illuminates when malfunction occurs in 2 continuous driving cycles.

• Normality Judgment

Judge OK when the malfunction criteria below are continued for 10 seconds.

• Judgment Value

Malfunction Criteria	Threshold Value
$\text{fsobd} = (\text{sglmd} - \text{tglm da}) + \text{faf} + \text{flaf}$	$< 19\%$

DIAGNOSTIC TROUBLE CODE (DTC) DETECTING CRITERIA

GENERAL DESCRIPTION

5. DTC CLEAR CONDITION

- When the OK idling cycle was completed 40 times in a row
- When "Clear Memory" was performed

6. MALFUNCTION INDICATOR LIGHT CLEAR CONDITION

- When OK with similar drive in 3 driving cycles.
- When "Clear Memory" was performed

7. FAIL SAFE

Rich side malfunction

- Purge control solenoid valve control: Not allowed to purge.
- Heavy fuel judgment control: Not allowed to carry out the heavy judgment.

8. ECM OPERATING AT DTC SETTING

Memorize the freeze frame data. (For test mode \$02)

DIAGNOSTIC TROUBLE CODE (DTC) DETECTING CRITERIA

GENERAL DESCRIPTION

MEMO:

DIAGNOSTIC TROUBLE CODE (DTC) DETECTING CRITERIA

GENERAL DESCRIPTION

AF:DTC P0172 — SYSTEM TOO RICH (BANK 1) —

1. OUTLINE OF DIAGNOSIS

Detect the fuel system malfunction by the amount of main feedback control.

• Fuel System Diagnosis

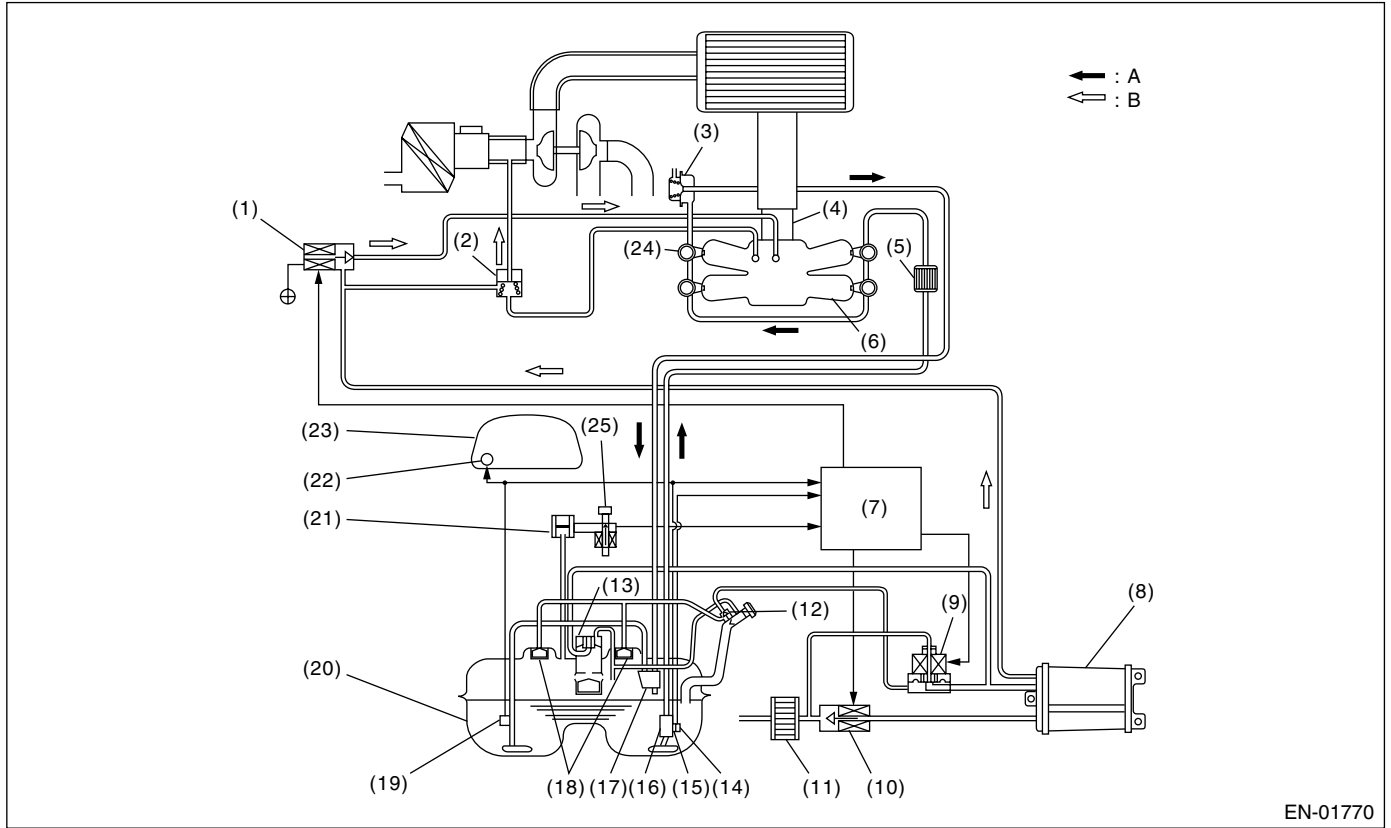

EN-01770

- | | | |
|-------------------------------------|------------------------------|---|
| (1) Purge control solenoid valve | (10) Drain valve | (19) Fuel sub level sensor |
| (2) Purge valve | (11) Drain filter | (20) Fuel tank |
| (3) Pressure regulator | (12) Shut-off valve | (21) Fuel tank pressure sensor |
| (4) Throttle body | (13) Vent valve | (22) Fuel meter |
| (5) Fuel filter | (14) Fuel temperature sensor | (23) Combination meter |
| (6) Intake manifold | (15) Fuel level sensor | (24) Fuel injector |
| (7) Engine control module (ECM) | (16) Fuel pump | (25) Tank pressure switching solenoid valve |
| (8) Canister | (17) Jet pump | |
| (9) Pressure control solenoid valve | (18) Fuel cut valve | |

• Diagnostic Method

Fuel system is diagnosed by comparing the target air fuel ratio calculated by ECM with the actual air fuel ratio measured by sensor.

DIAGNOSTIC TROUBLE CODE (DTC) DETECTING CRITERIA

GENERAL DESCRIPTION

2. ENABLE CONDITION

Secondary Parameters	Enable Conditions
A/F main learning system	In operation
Engine coolant temperature	≥75°C (167°F)
Engine load	≥ Map 5
Intake air change during 0.5 engine rev.	≤ 0.02 g (0.001 oz)/rev
Learning value of EVAP conc. during purge	≤ 0.1
Cumulative time of canister purge after engine start	20 seconds or more
Continuous period after canister purge starting	30 seconds or more

Map 5

Engine speed (rpm)	idle	800	1200	1600	2000	2400	2800	3200	3600	4000	4400
Measured value (g (oz)/rev)	NA	0.236 (0.008)	0.232 (0.008)	0.226 (0.008)	0.231 (0.008)	0.252 (0.009)	0.262 (0.009)	0.243 (0.009)	0.243 (0.009)	0.267 (0.009)	0.270 (0.010)

3. GENERAL DRIVING CYCLE

Perform the diagnosis continuously at idling or a constant speed after warming up the engine.

4. DIAGNOSTIC METHOD

• Abnormality Judgment

Judge that the fuel system malfunction occurs when the time during completing the malfunction criteria below continues 30 seconds or more by comparing the diagnosed value (fsobd) with threshold value.

• Judgment Value

Malfunction Criteria	Threshold Value
$fsobd = (sglmd - tglmda) + faf + flaf$ where, sglmd = measured lambda tglmda = target lambda faf = main feedback compensation coefficient every 64 milliseconds flaf = main feedback learning compensation coefficient	$\leq fsobdR1$ See Map 4 fsobdR1 = rich side threshold value of fsobd

Map 4 Threshold value for fuel system malfunction criteria

Amount of air (g/s)	0 (0)	2.4 (0.085)	4.7 (0.166)	7 (0.247)	9.4 (0.332)	11.7 (0.413)	
fsobdR1 (%)	-40	-40	-36.9	-32.0	-27.0	-27.0	

Time Needed for Diagnosis: 10 seconds × 3 times

Malfunction Indicator Light Illumination: Illuminates when malfunction occurs in 2 continuous driving cycles.

• Normality Judgment

Judge OK when the malfunction criteria below are continued for 10 seconds.

• Judgment Value

Malfunction Criteria	Threshold Value
$fsobd = (sglmd - tglmda) + faf + flaf$	≥ -20%

DIAGNOSTIC TROUBLE CODE (DTC) DETECTING CRITERIA

GENERAL DESCRIPTION

5. DTC CLEAR CONDITION

- When the OK idling cycle was completed 40 times in a row
- When "Clear Memory" was performed

6. MALFUNCTION INDICATOR LIGHT CLEAR CONDITION

- When OK with similar drive in 3 drive cycles.
- When "Clear Memory" was performed

7. FAIL SAFE

Rich side malfunction

- Purge control solenoid valve control: Not allowed to purge.
- Heavy fuel judgment control: Not allowed to carry out the heavy judgment.

8. ECM OPERATING AT DTC SETTING

Memorize the freeze frame data. (For test mode \$02)

DIAGNOSTIC TROUBLE CODE (DTC) DETECTING CRITERIA

GENERAL DESCRIPTION

AG:DTC P0181 — FUEL TEMPERATURE SENSOR “A” CIRCUIT RANGE/PERFORMANCE —

1. OUTLINE OF DIAGNOSIS

Detect the malfunction of fuel temperature sensor output property. Perform the diagnosis in two methods; namely, drift diagnosis and stuck diagnosis. Judge NG when either of them results in NG, and judge OK when both of them result in OK.

• Drift Diagnosis

Normally fuel temperature is lower than engine coolant temperature. When the fuel temperature becomes higher than the engine coolant temperature, the range is considered to be shifted, and make an NG judgment.

2. COMPONENT DESCRIPTION

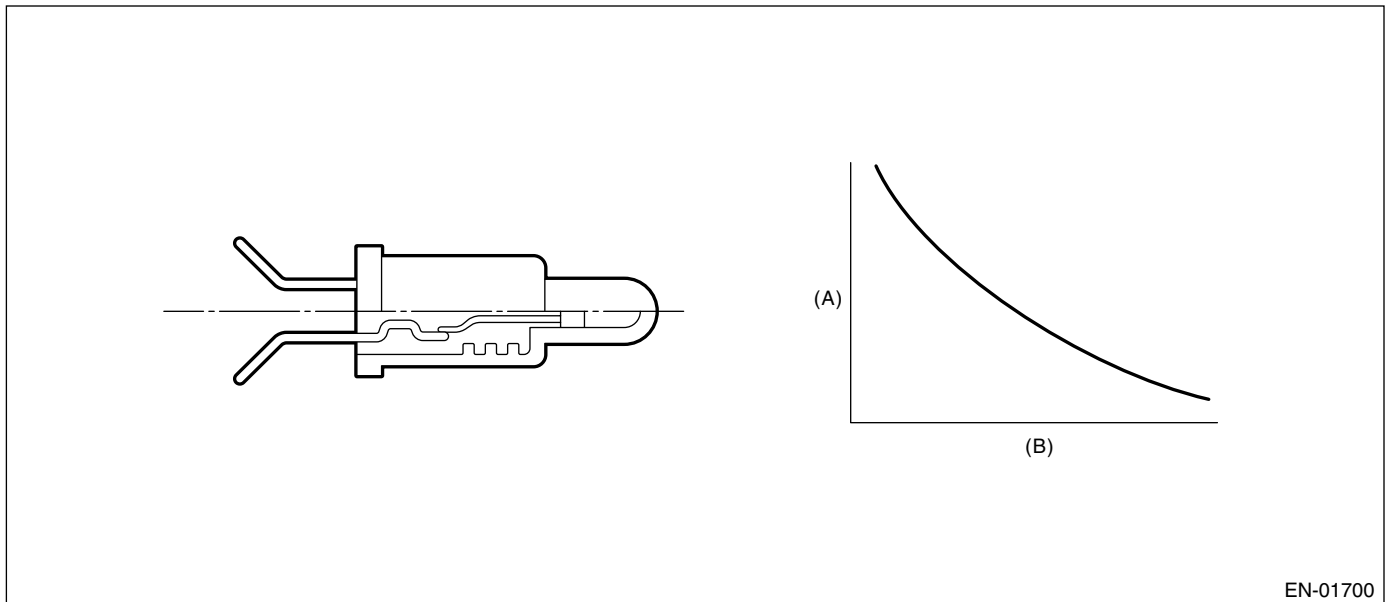

EN-01700

(A) Resistance (Ω)

(B) Fuel temperature $^{\circ}\text{C}$ ($^{\circ}\text{F}$)

3. ENABLE CONDITION

Secondary Parameters	Enable Conditions
None	

4. GENERAL DRIVING CYCLE

Always perform the diagnosis continuously.

DIAGNOSTIC TROUBLE CODE (DTC) DETECTING CRITERIA

GENERAL DESCRIPTION

5. DIAGNOSTIC METHOD

• Abnormality Judgment

Judge NG when the continuous time of completing the malfunction criteria below becomes more than 120 seconds.

• Judgment Value

Malfunction Criteria	Threshold Value
Fuel level	$\geq 10 \ell$ (2.64 US gal, 2.20 Imp gal)
After starting engine	20 seconds or more
Engine coolant temperature – engine coolant temperature at engine starting	$> 10^{\circ}\text{C}$ (50°F)
Fuel temperature – engine coolant temperature	$\geq 10^{\circ}\text{C}$ (50°F)
Battery voltage	$> 10.9 \text{ V}$

Time Needed for Diagnosis: 120 seconds

Malfunction Indicator Light Illumination: Illuminates when malfunction occurs in 2 continuous driving cycles.

• Normality Judgment

Judge OK when the malfunction criteria below are completed.

• Judgment Value

Malfunction Criteria	Threshold Value
Fuel level	$\geq 10 \ell$ (2.64 US gal, 2.20 Imp gal)
After starting engine	20 seconds or more
Engine coolant temperature – engine coolant temperature at engine starting	$> 10^{\circ}\text{C}$ (50°F)
Fuel temperature – engine coolant temperature	$< 10^{\circ}\text{C}$ (50°F)
Battery voltage	$> 10.9 \text{ V}$

• Stuck Diagnosis

If the fuel temperature which might rise along with the engine idling (the cumulative amount of intake air after engine starting is large) does not increase, the engine is considered to be stuck and make an NG judgment.

6. ENABLE CONDITION

Secondary Parameters	Enable Conditions
After starting engine	20 seconds or more
Battery voltage	$> 10.9 \text{ V}$

7. GENERAL DRIVING CYCLE

Perform the diagnosis continuously in 20 seconds or more after starting the engine.

DIAGNOSTIC TROUBLE CODE (DTC) DETECTING CRITERIA

GENERAL DESCRIPTION

8. DIAGNOSTIC METHOD

• Abnormality Judgment

Judge NG when the malfunction criteria below are completed.

• Judgment Value

Malfunction Criteria	Threshold Value
Accumulated amount of intake air	≥ 550 kg (1212.5 lb)
Fuel temperature difference between Max. and Min.	$< 3^{\circ}\text{C}$ (37.4 $^{\circ}\text{F}$)

Time Needed for Diagnosis: To be determined.

Malfunction Indicator Light Illumination: Illuminates when malfunction occurs in 2 continuous driving cycles.

• Normality Judgment

Judge OK when the malfunction criteria below are completed.

• Judgment Value

Malfunction Criteria	Threshold Value
Accumulated amount of intake air	≥ 550 kg (1212.5 lb)
Fuel temperature difference between Max. and Min.	$\geq 3^{\circ}\text{C}$ (37.4 $^{\circ}\text{F}$)

9. DTC CLEAR CONDITION

- When the OK idling cycle was completed 40 times in a row
- When "Clear Memory" was performed

10.MALFUNCTION INDICATOR LIGHT CLEAR CONDITION

- When the OK driving cycle was completed 3 times in a row
- When "Clear Memory" was performed

11.FAIL SAFE

None

12.ECM OPERATING AT DTC SETTING

Memorize the freeze frame data. (For test mode \$02)

DIAGNOSTIC TROUBLE CODE (DTC) DETECTING CRITERIA

GENERAL DESCRIPTION

AH:DTC P0182 — FUEL TEMPERATURE SENSOR “A” CIRCUIT LOW INPUT —

1. OUTLINE OF DIAGNOSIS

Detect the open or short circuit of fuel temperature sensor. Judge NG when out of the standard value.

2. COMPONENT DESCRIPTION

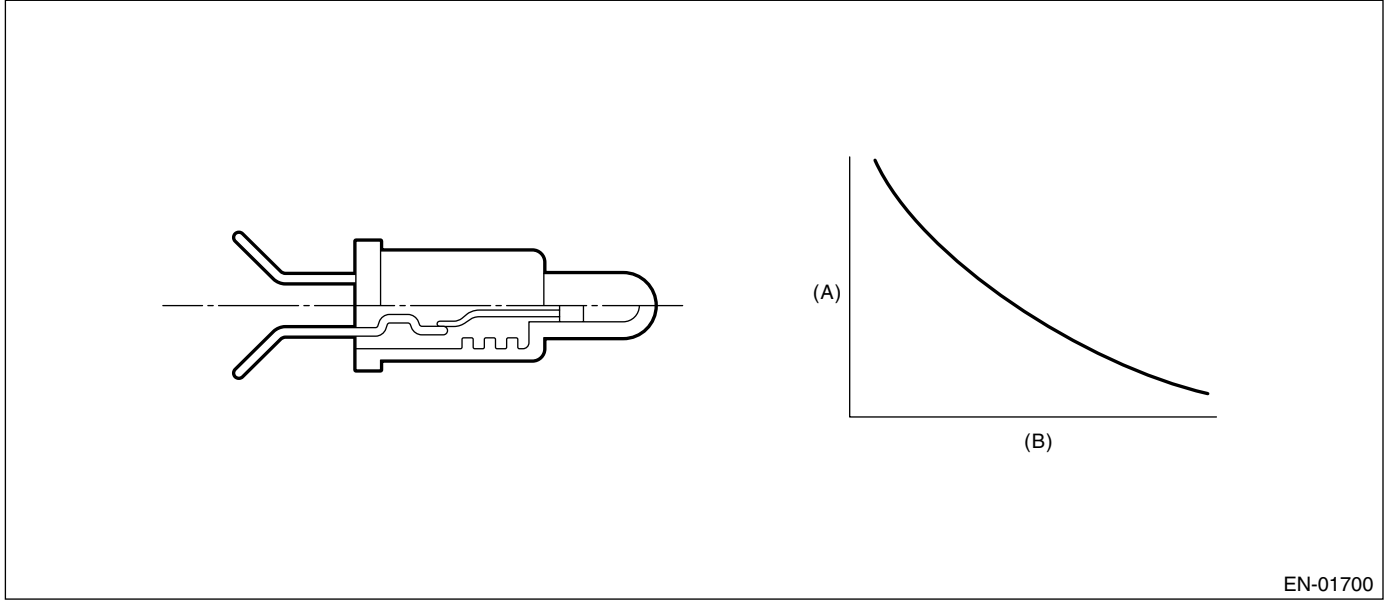

(A) Resistance (Ω)

(B) Fuel temperature °C (°F)

3. ENABLE CONDITION

Secondary Parameters	Enable Conditions
None	

4. GENERAL DRIVING CYCLE

Always perform the diagnosis continuously.

5. DIAGNOSTIC METHOD

• Abnormality Judgment

Judge NG when the continuous time of completing the malfunction criteria below becomes more than 2.5 seconds.

• Judgment Value

Malfunction Criteria	Threshold Value
Output voltage	< 0.1646 V
Battery voltage	≥ 10.9 V

Time Needed for Diagnosis: 2.5 seconds

Malfunction Indicator Light Illumination: Illuminates as soon as the malfunction occurs.

• Normality Judgment

Judge OK when the cumulative time until completing the malfunction criteria below becomes more than 2.5 seconds.

• Judgment Value

Malfunction Criteria	Threshold Value
Output voltage	≥ 0.1646 V
Battery voltage	≥ 10.9 V

DIAGNOSTIC TROUBLE CODE (DTC) DETECTING CRITERIA

GENERAL DESCRIPTION

6. DTC CLEAR CONDITION

- When the OK idling cycle was completed 40 times in a row
- When "Clear Memory" was performed

7. MALFUNCTION INDICATOR LIGHT CLEAR CONDITION

- When the OK driving cycle was completed 3 times in a row
- When "Clear Memory" was performed

8. FAIL SAFE

None

9. ECM OPERATING AT DTC SETTING

Memorize the freeze frame data. (For test mode \$02)

DIAGNOSTIC TROUBLE CODE (DTC) DETECTING CRITERIA

GENERAL DESCRIPTION

AI: DTC P0183 — FUEL TEMPERATURE SENSOR “A” CIRCUIT HIGH INPUT —

1. OUTLINE OF DIAGNOSIS

Detect the open or short circuit of fuel temperature sensor. Judge NG when out of the standard value.

2. COMPONENT DESCRIPTION

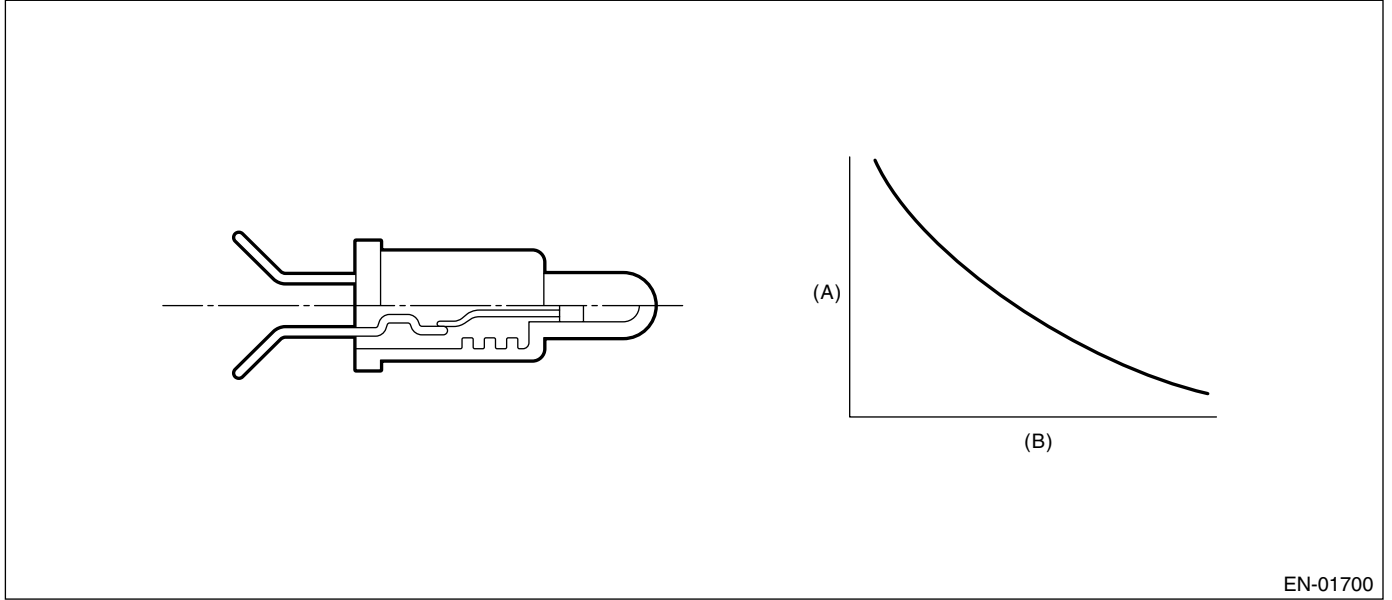

EN-01700

(A) Resistance (Ω)

(B) Fuel temperature °C (°F)

3. ENABLE CONDITION

Secondary Parameters	Enable Conditions
None	

4. GENERAL DRIVING CYCLE

Always perform the diagnosis continuously.

5. DIAGNOSTIC METHOD

• Abnormality Judgment

Judge NG when the continuous time of completing the malfunction criteria below becomes more than 2.5 seconds.

• Judgment Value

Malfunction Criteria	Threshold Value
Output voltage	$\geq 4.72 \text{ V}$
Battery voltage	$\geq 10.9 \text{ V}$

Time Needed for Diagnosis: 2.5 seconds

Malfunction Indicator Light Illumination: Illuminates as soon as the malfunction occurs.

• Normality Judgment

Judge OK when the cumulative time until completing the malfunction criteria below becomes more than 2.5 seconds.

• Judgment Value

Malfunction Criteria	Threshold Value
Output voltage	$< 4.72 \text{ V}$
Battery voltage	$\geq 10.9 \text{ V}$

DIAGNOSTIC TROUBLE CODE (DTC) DETECTING CRITERIA

GENERAL DESCRIPTION

6. DTC CLEAR CONDITION

- When the OK idling cycle was completed 40 times in a row
- When "Clear Memory" was performed

7. MALFUNCTION INDICATOR LIGHT CLEAR CONDITION

- When the OK driving cycle was completed 3 times in a row
- When "Clear Memory" was performed

8. FAIL SAFE

None

9. ECM OPERATING AT DTC SETTING

Memorize the freeze frame data. (For test mode \$02)

DIAGNOSTIC TROUBLE CODE (DTC) DETECTING CRITERIA

GENERAL DESCRIPTION

AJ:DTC P0222 — THROTTLE/PEDAL POSITION SENSOR/SWITCH “B” CIRCUIT LOW INPUT —

1. OUTLINE OF DIAGNOSIS

Detect the open or short circuit of throttle position sensor 2.
Judge NG when out of the standard value.

2. COMPONENT DESCRIPTION

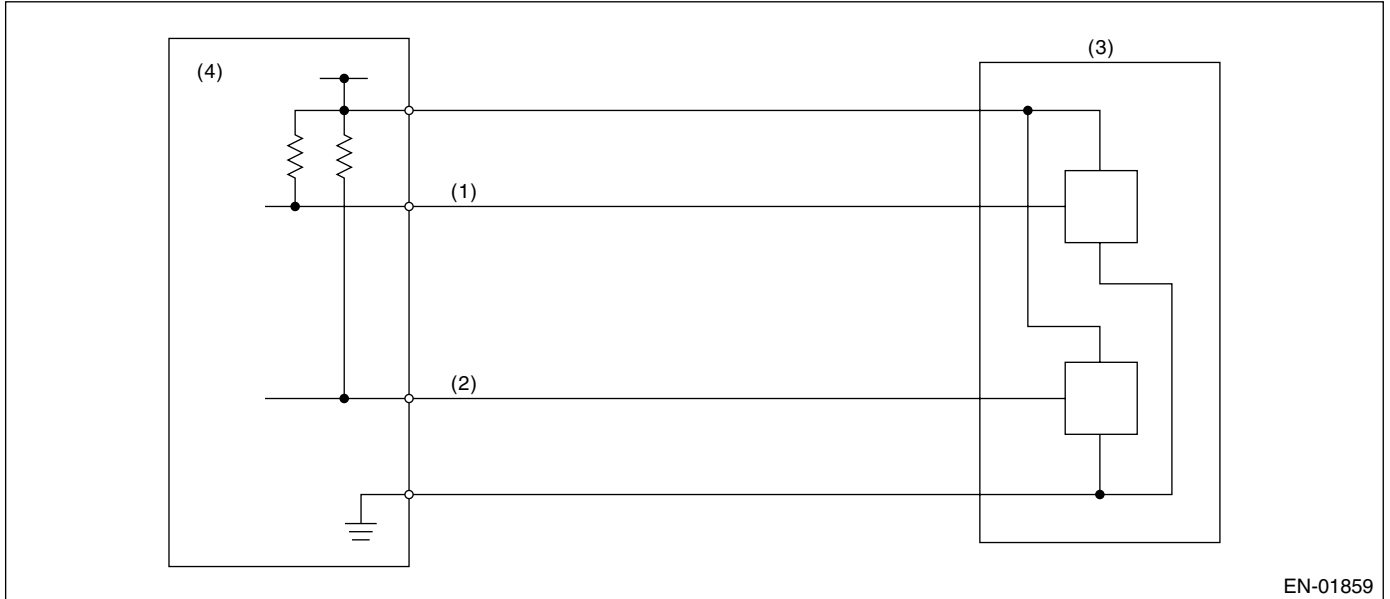

EN-01859

- (1) Throttle position sensor 1 signal (3) Throttle position sensor
(2) Throttle position sensor 2 signal (4) Engine control module (ECM)

3. ENABLE CONDITION

Secondary Parameters	Enable Conditions
Ignition switch	ON

4. GENERAL DRIVING CYCLE

Always perform the diagnosis continuously.

5. DIAGNOSTIC METHOD

Judge OK and clear the NG when the malfunction criteria below are completed.

Judgment Value

Malfunction Criteria	Threshold Value
Sensor 1 input voltage	≤ 0.749 V

Time Needed for Diagnosis: 24 milliseconds

Malfunction Indicator Light Illumination: Illuminates as soon as malfunction occurs.

6. DTC CLEAR CONDITION

- When the OK idling cycle was completed 40 times in a row
- When “Clear Memory” was performed (Only engine stop)

7. MALFUNCTION INDICATOR LIGHT CLEAR CONDITION

- When the OK driving cycle was completed 3 times in a row
- When “Clear Memory” was performed (Only engine stop)

DIAGNOSTIC TROUBLE CODE (DTC) DETECTING CRITERIA

GENERAL DESCRIPTION

8. FAIL SAFE

Stop power distribution to electric control throttle motor. (Throttle opening is fixed to 6°.)

9. ECM OPERATION AT DTC SETTING

Memorize the freeze frame data. (For test mode \$02)

DIAGNOSTIC TROUBLE CODE (DTC) DETECTING CRITERIA

GENERAL DESCRIPTION

AK:DTC P0223 — THROTTLE/PEDAL POSITION SENSOR/SWITCH “B” CIRCUIT HIGH INPUT —

1. OUTLINE OF DIAGNOSIS

Detect the open or short circuit of throttle position sensor 2.
Judge NG when out of the standard value.

2. COMPONENT DESCRIPTION

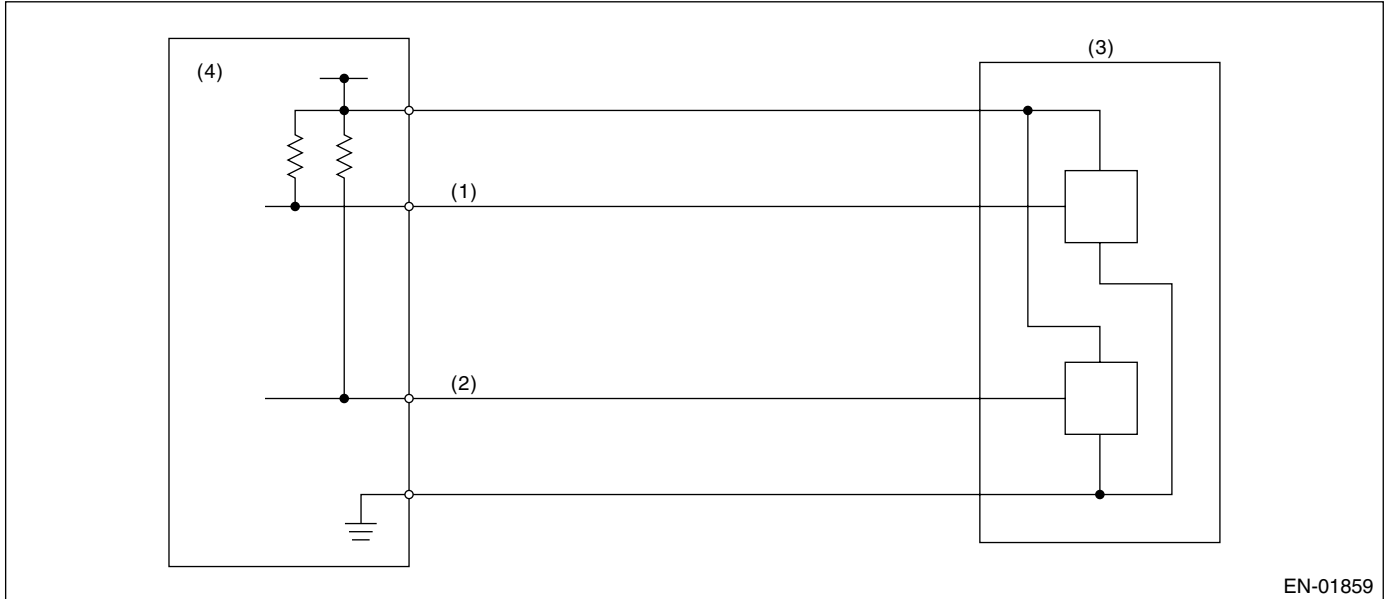

EN-01859

- (1) Throttle position sensor 1 signal (3) Throttle position sensor
(2) Throttle position sensor 2 signal (4) Engine control module (ECM)

3. ENABLE CONDITION

Secondary Parameters	Enable Conditions
Ignition switch	ON

4. GENERAL DRIVING CYCLE

Always perform the diagnosis continuously.

5. DIAGNOSTIC METHOD

Judge OK and clear the NG when the malfunction criteria below are completed.

Judgment Value

Malfunction Criteria	Threshold Value
Sensor 1 input voltage	≥ 4.747 V

Time Needed for Diagnosis: 24 milliseconds

Malfunction Indicator Light Illumination: Illuminates as soon as malfunction occurs.

6. DTC CLEAR CONDITION

- When the OK idling cycle was completed 40 times in a row
- When “Clear Memory” was performed (Only engine stop)

7. MALFUNCTION INDICATOR LIGHT CLEAR CONDITION

- When the OK driving cycle was completed 3 times in a row
- When “Clear Memory” was performed (Only engine stop)

DIAGNOSTIC TROUBLE CODE (DTC) DETECTING CRITERIA

GENERAL DESCRIPTION

8. FAIL SAFE

Stop power distribution to electric control throttle motor. (Throttle opening is fixed to 6°.)

9. ECM OPERATION AT DTC SETTING

Memorize the freeze frame data. (For test mode \$02)

DIAGNOSTIC TROUBLE CODE (DTC) DETECTING CRITERIA

GENERAL DESCRIPTION

AL:DTC P0230 — FUEL PUMP PRIMARY CIRCUIT —

1. OUTLINE OF DIAGNOSIS

Detect the malfunction of fuel pump control unit. Judge NG when the NG signal is sent through a diagnostic line coming from the fuel pump control unit. Fuel pump control unit detects the open or short circuit malfunction for each line, and then sends NG signals if one of them is found NG.

2. COMPONENT DESCRIPTION

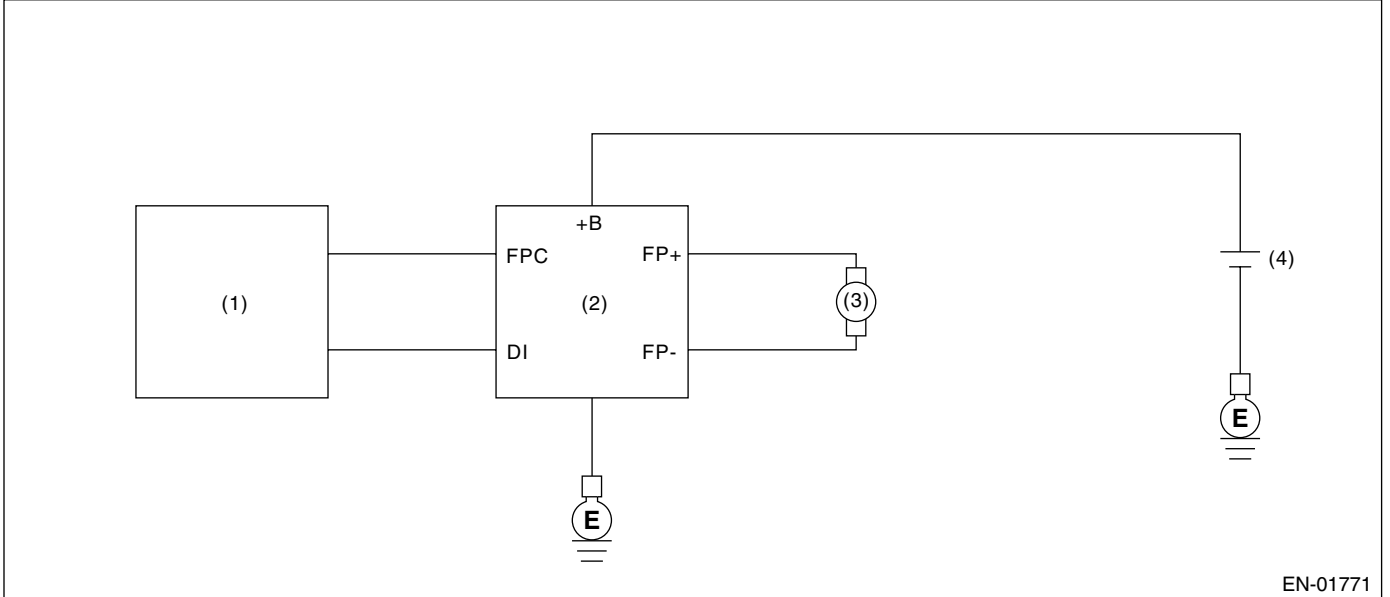

- (1) Engine control module (ECM) (3) Fuel pump
(2) Fuel pump control unit (4) Battery

3. ENABLE CONDITION

Secondary Parameters	Enable Conditions
None	

4. GENERAL DRIVING CYCLE

Always perform the diagnosis continuously.

DIAGNOSTIC TROUBLE CODE (DTC) DETECTING CRITERIA

GENERAL DESCRIPTION

5. DIAGNOSTIC METHOD

• Abnormality Judgment

Judge NG when the continuous time of completing the malfunction criteria below becomes more than 2.5 seconds.

• Judgment Value

Malfunction Criteria	Threshold Value
Battery voltage	$\geq 8\text{ V}$
After starting engine	30 seconds or more
Fuel pump control	ON
Fuel pump control unit output diagnosis signal	Low

Time Needed for Diagnosis: 2.5 seconds

Malfunction Indicator Light Illumination: Illuminates when malfunction occurs in 2 continuous driving cycles.

• Normality Judgment

Judge OK and clear the NG when the malfunction criteria below are completed.

• Judgment Value

Malfunction Criteria	Threshold Value
Battery voltage	$\geq 8\text{ V}$
After starting engine	30 seconds or more
Fuel pump control	ON
Fuel pump control unit output diagnosis signal	High

6. DTC CLEAR CONDITION

- When the OK idling cycle was completed 40 times in a row
- When "Clear Memory" was performed

7. MALFUNCTION INDICATOR LIGHT CLEAR CONDITION

- When the OK driving cycle was completed 3 times in a row
- When "Clear Memory" was performed

8. FAIL SAFE

OFF setting may be needed depending on the NG portion.

9. ECM OPERATING AT DTC SETTING

Memorize the freeze frame data. (For test mode \$02)

DIAGNOSTIC TROUBLE CODE (DTC) DETECTING CRITERIA

GENERAL DESCRIPTION

AM:DTC P0244 — TURBO/SUPER CHARGER WASTEGATE SOLENOID “A” RANGE/PERFORMANCE —

1. OUTLINE OF DIAGNOSIS

Detect the malfunction of wastegate control solenoid valve function. Judge NG when becoming high wastegate pressure.

2. COMPONENT DESCRIPTION

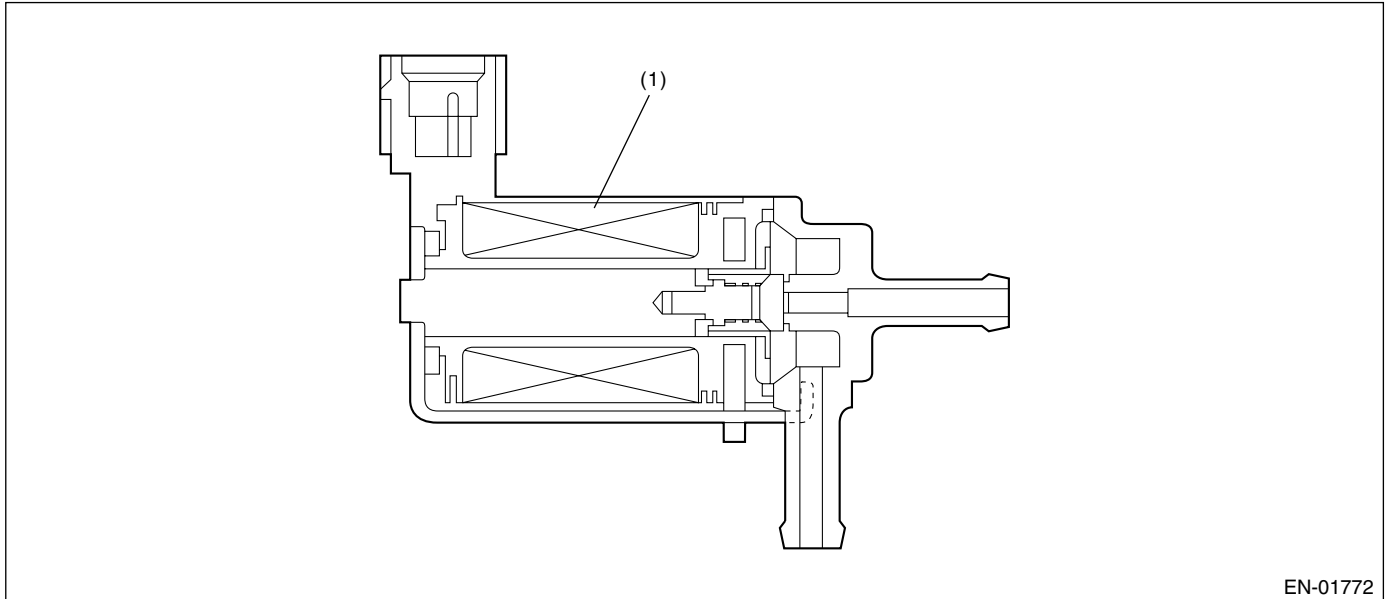

(1) Coil

3. ENABLE CONDITION

Secondary Parameters	Enable Conditions
None	

4. GENERAL DRIVING CYCLE

Always perform the diagnosis continuously.

DIAGNOSTIC TROUBLE CODE (DTC) DETECTING CRITERIA

GENERAL DESCRIPTION

5. DIAGNOSTIC METHOD

• Abnormality Judgment

Judge NG when the continuous time of completing the malfunction criteria below becomes more than 1 second.

• Judgment Value

Malfunction Criteria	Threshold Value
Intake manifold pressure	≥ Map 10

• Map 10

Pa (kPa (mmHg, inHg))	56.7 (440,17.3)	67.2 (504, 19.8)	75.7 (568, 22.4)	84.3 (632, 24.9)	92.8 (696, 27.4)	101.3 (760, 29.9)
Abnormal threshold (kPa (mmHg, inHg))	152.6 (1145, 45.08)	165.4 (1241, 48.8)	177.2 (1329, 52.3)	189.0 (1418, 55.8)	200.7 (1506, 59.3)	212.5 (1594, 62.8)
Normal threshold (kPa (mmHg, inHg))	130.2 (977, 38.5)	143.0 (1073, 42.2)	154.8 (1161, 45.7)	166.6 (1250, 49.2)	178.4 (1338, 52.7)	190.1 (1426, 56.1)

Time Needed for Diagnosis: 1 second

Malfunction Indicator Light Illumination: Illuminates as soon as malfunction occurs.

• Normality Judgment

Judge OK and clear the NG when the malfunction criteria below are completed.

• Judgment Value

Malfunction Criteria	Threshold Value
Intake manifold pressure	< Map 10

6. DTC CLEAR CONDITION

- When the OK idling cycle was completed 40 times in a row
- When "Clear Memory" was performed

7. MALFUNCTION INDICATOR LIGHT CLEAR CONDITION

- When the OK driving cycle was completed 3 times in a row
- When "Clear Memory" was performed

8. FAIL SAFE

None

9. ECM OPERATING AT DTC SETTING

Memorize the freeze frame data. (For test mode \$02)

DIAGNOSTIC TROUBLE CODE (DTC) DETECTING CRITERIA

GENERAL DESCRIPTION

AN:DTC P0245 — TURBO/SUPER CHARGER WASTEGATE SOLENOID “A” LOW —

1. OUTLINE OF DIAGNOSIS

Detect the open or short circuit of wastegate control solenoid valve. Judge NG when the terminal output voltage remains Low during outputting the duty signal.

2. COMPONENT DESCRIPTION

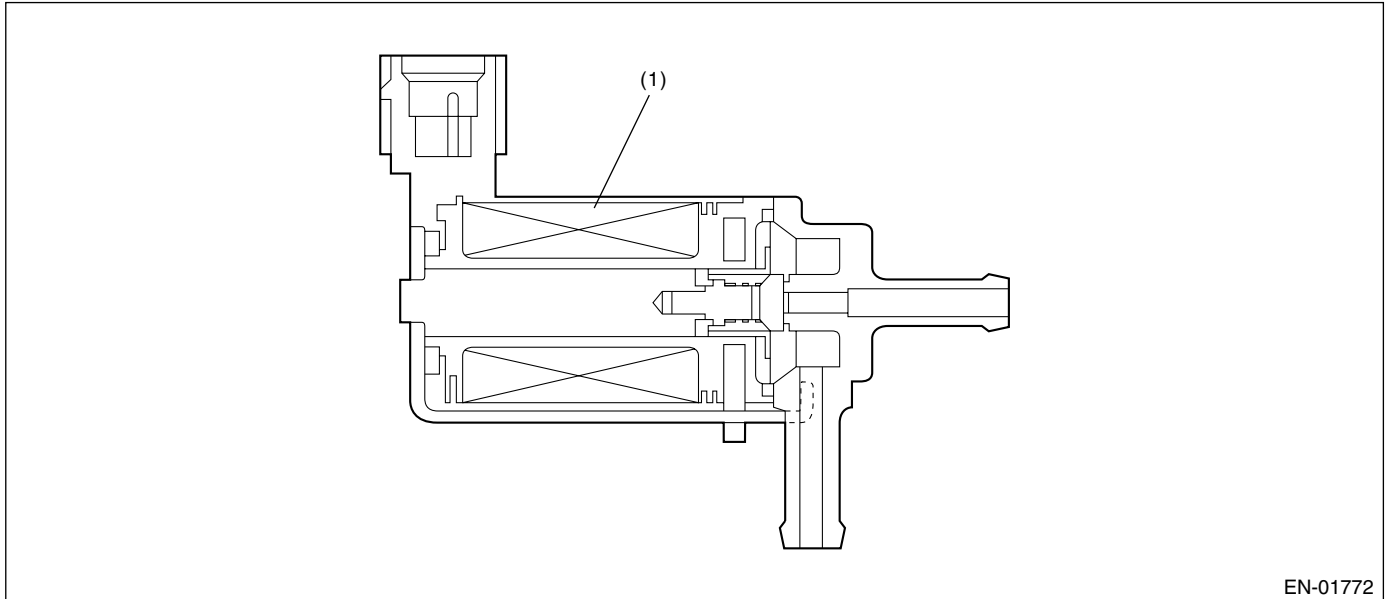

EN-01772

(1) Coil

3. ENABLE CONDITION

Secondary Parameters	Enable Conditions
Battery voltage	> 10.9 V
After starting engine	1 second or more

4. GENERAL DRIVING CYCLE

Perform the diagnosis continuously after starting the engine.

DIAGNOSTIC TROUBLE CODE (DTC) DETECTING CRITERIA

GENERAL DESCRIPTION

5. DIAGNOSTIC METHOD

• Abnormality Judgment

Judge NG when the continuous time until completing the malfunction criteria below becomes more than 655 milliseconds.

• Judgment Value

Malfunction Criteria	Threshold Value
Terminal output voltage	Low
Duty ratio for turbocharged pressure control	< 75%

Time Needed for Diagnosis: 655 milliseconds

Malfunction Indicator Light Illumination: Illuminates as soon as the malfunction occurs.

• Normality Judgment

Judge OK and clear the NG when the malfunction criteria below are completed.

• Judgment Value

Malfunction Criteria	Threshold Value
Terminal output voltage	High

6. DTC CLEAR CONDITION

- When the OK idling cycle was completed 40 times in a row
- When "Clear Memory" was performed

7. MALFUNCTION INDICATOR LIGHT CLEAR CONDITION

- When the OK driving cycle was completed 3 times in a row
- When "Clear Memory" was performed

8. FAIL SAFE

None

9. ECM OPERATING AT DTC SETTING

Memorize the freeze frame data. (For test mode \$02)

DIAGNOSTIC TROUBLE CODE (DTC) DETECTING CRITERIA

GENERAL DESCRIPTION

AO:DTC P0246 — TURBO/SUPER CHARGER WASTEGATE SOLENOID “A” HIGH —

1. OUTLINE OF DIAGNOSIS

Detect the open or short circuit of wastegate control solenoid valve. Judge NG when the terminal output voltage remains Low or High during outputting the duty signal.

2. COMPONENT DESCRIPTION

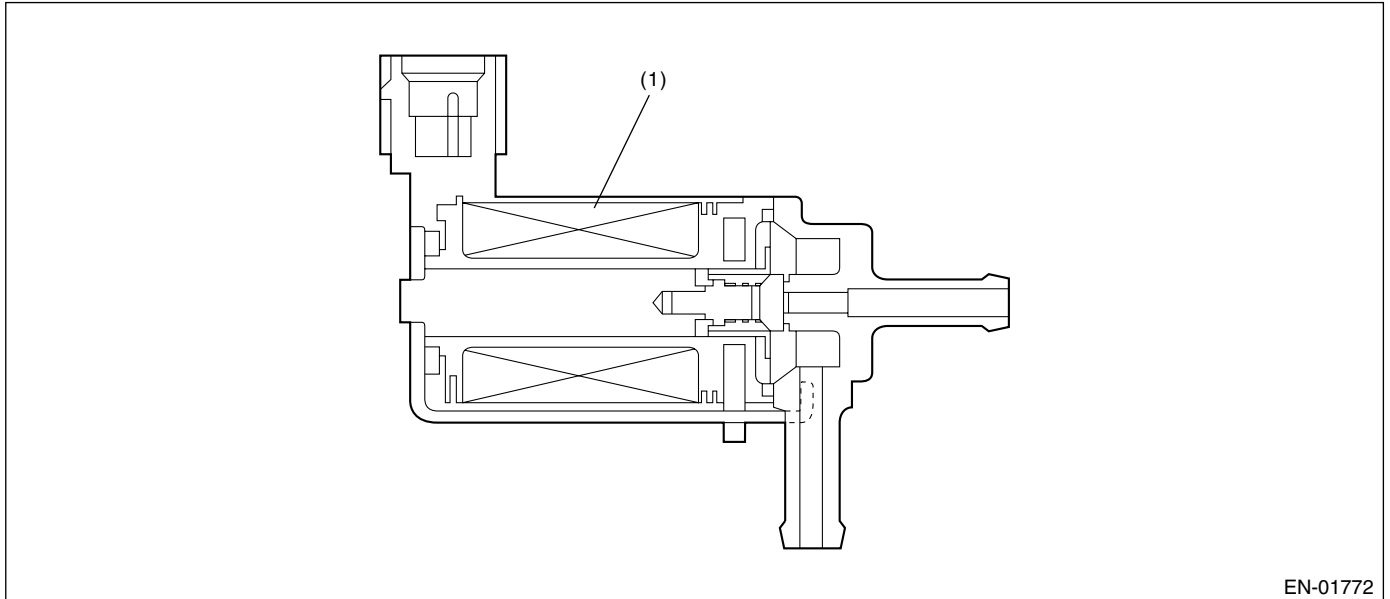

(1) Coil

3. ENABLE CONDITION

Secondary Parameters	Enable Conditions
Battery voltage	> 10.9 V
After starting engine	1 second or more

4. GENERAL DRIVING CYCLE

Perform the diagnosis continuously after starting the engine.

DIAGNOSTIC TROUBLE CODE (DTC) DETECTING CRITERIA

GENERAL DESCRIPTION

5. DIAGNOSTIC METHOD

• Abnormality Judgment

Judge NG when the continuous time until completing the malfunction criteria below becomes more than 655 milliseconds.

• Judgment Value

Malfunction Criteria	Threshold Value
Terminal output voltage	High
Duty ratio for turbocharged pressure control	> 25%

Time Needed for Diagnosis: 655 milliseconds

Malfunction Indicator Light Illumination: Illuminates as soon as the malfunction occurs.

• Normality Judgment

Judge OK and clear the NG when the malfunction criteria below are completed.

• Judgment Value

Malfunction Criteria	Threshold Value
Terminal output voltage	Low

6. DTC CLEAR CONDITION

- When the OK idling cycle was completed 40 times in a row
- When "Clear Memory" was performed

7. MALFUNCTION INDICATOR LIGHT CLEAR CONDITION

- When the OK driving cycle was completed 3 times in a row
- When "Clear Memory" was performed

8. FAIL SAFE

None

9. ECM OPERATING AT DTC SETTING

Memorize the freeze frame data. (For test mode \$02)

DIAGNOSTIC TROUBLE CODE (DTC) DETECTING CRITERIA

GENERAL DESCRIPTION

AP:DTC P0301 — CYLINDER 1 MISFIRE DETECTED —

1. OUTLINE OF DIAGNOSIS

Detect whether the misfire occurred or not. (Revolution fluctuation method) Monitoring the misfire which influences exhaust deterioration (1.5 times of FTP) and catalyst damage is made obligatory by the law. Misfire affecting these two has three patterns below.

- Intermittent misfire (The same cylinder misfires in random, or different cylinders misfire in random.): FTP 1.5 times misfire
- Every time misfire (The same cylinder misfires every time.): FTP 1.5 times misfire, Catalyst damage misfire

The following detecting methods are adopted for these detection.

1) Intermittent misfire: FTP 1.5 times misfire

- 180° Interval Difference Method (MT: 1,800 rpm or less; AT: None)
- 360° Interval Difference Method (whole range)
- 720° Interval Difference Method (3,000 rpm or less)

2) Every time misfire: FTP 1.5 times misfire, Catalyst damage misfire

- 360° Interval Difference Method

2. ENABLE CONDITION

Secondary Parameters	Enable Conditions
All secondary parameters approval continuation time	1 second or more
Intake manifold pressure change during 0.5 engine rev.	< 16.0 kPa (120 mmHg, 4.72 inHg) (MT) < 14.7 kPa (110 mmHg, 4.33 inHg) (AT)
Engine speed change	< 500 rpm/32 milliseconds
Throttle position change during 16 milliseconds	< 10°
Fuel shut-off function	Not in operation
Atmospheric pressure	≥ 75.1 kPa (563 mmHg, 22.2 inHg)
Fuel level	≥ 9.6 ℓ (2.54 US gal, 2.11 Imp gal)
Air condition	No switching ON ↔ OFF
Radiator fan	No switching ON ↔ OFF
Power steering switch	No switching ON ↔ OFF
Starter	ON, or OFF, or change from ON to OFF
Evaporative system leak check	Not in operation
Engine speed	500 — 6700 rpm
Intake manifold pressure	> Map 3 or more
Battery voltage	≥ 8 V
Engine coolant temperature	≤ 111°C (232°F)
Intake air temperature	≤ 101°C (214°F)
Heavy quality fuel judgement	Does not execute.
VDC and AT control	Is not controlling.

DIAGNOSTIC TROUBLE CODE (DTC) DETECTING CRITERIA

GENERAL DESCRIPTION

Map3

- MT

Vehicle Speed < 64.4 km/h (40 MPH)

rpm	700	1000	1500	2000	2500	3000	3500	4000	4500	5000	5500	6000	6500	6700
kPa	25.1	24.8	25.6	23.3	26.3	25.9	28.9	30.0	31.7	33.0	37.1	41.9	47.0	51.1
(mmHg, inHg)	(188, 7.40)	(186, 7.32)	(192, 7.56)	(175, 6.89)	(197, 7.76)	(194, 7.64)	(216.5, 8.52)	(225, 8.86)	(237.5, 9.35)	(248, 9.76)	(278.5, 11.0)	(314, 12.4)	(352.5, 13.9)	(383, 15.1)

Vehicle Speed ≥ 64.4 km/h (40 MPH)

rpm	700	1000	1500	2000	2500	3000	3500	4000	4500	5000	5500	6000	6500	6700
kPa	25.5	25.1	30.4	35.6	38.5	40.4	41.1	40.8	44.8	47.3	49.1	50.9	52.8	52.8
(mmHg, inHg)	(191, 7.52)	(188, 7.40)	(227.7, 8.96)	(267.4, 10.5)	(288.9, 11.4)	(302.9, 11.9)	(308.6, 12.1)	(306, 12.0)	(335.8, 13.2)	(354.5, 14.0)	(368.2, 14.5)	(381.9, 15.0)	(396, 15.6)	(396, 15.6)

- AT

Vehicle Speed ≥ 64.4 km/h (40 MPH)

rpm	700	1000	1500	2000	2500	3000	3500	4000	4500	5000	5500	6000	6500	6700
kPa	26.3	24.8	23.6	25.5	27.3	26.1	29.5	31.3	32.7	33.3	38.2	33.6	49.5	51.5
(mmHg, inHg)	(197, 7.76)	(186, 7.32)	(177, 6.97)	(191, 7.52)	(205, 8.07)	(196, 7.72)	(221.5, 8.72)	(235, 9.25)	(245.5, 9.67)	(250, 9.84)	(286.5, 11.3)	(252.3, 9.93)	(371.5, 14.62)	(386, 15.20)

3. GENERAL DRIVING CYCLE

- Detecting misfire is able to be carried out in the condition between idling and high revolution.
- Perform the diagnosis continuously.

4. DIAGNOSTIC METHOD

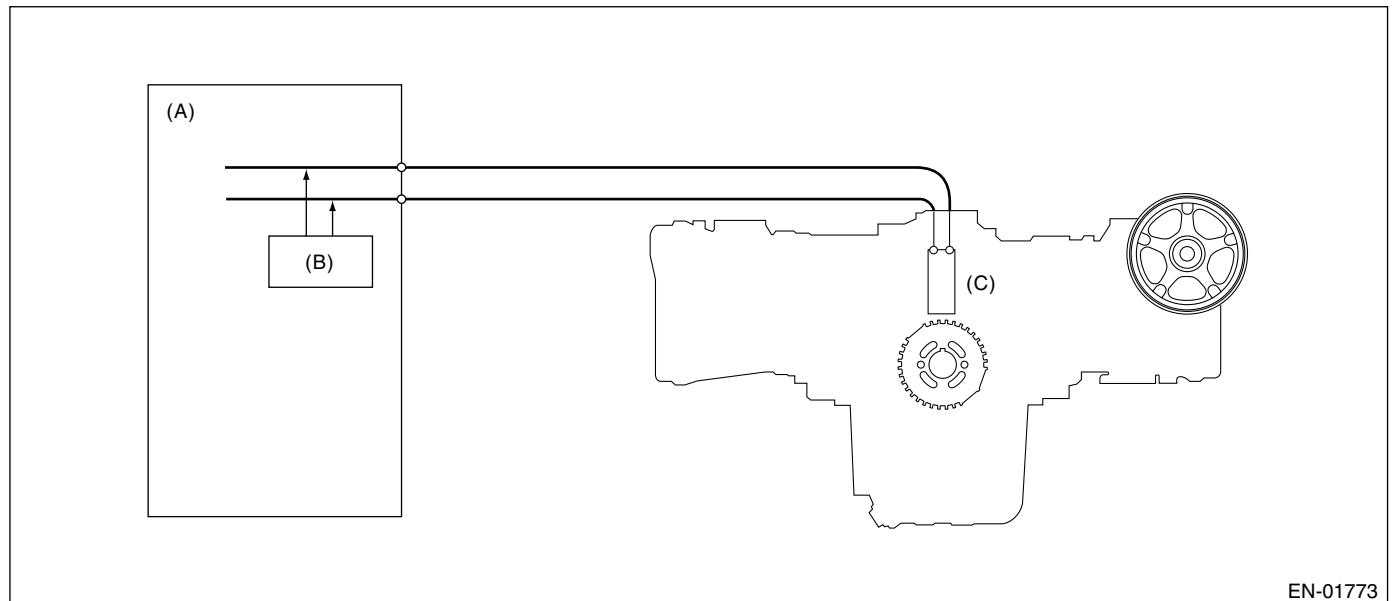

(A) Engine control module (ECM)

(B) Diagnosis circuit

(C) Crankshaft position sensor

DIAGNOSTIC TROUBLE CODE (DTC) DETECTING CRITERIA

GENERAL DESCRIPTION

When the misfire occurred, the engine speed is decreased and the crankshaft position speed will change. Calculate the interval difference value (diagnostic value) from crankshaft position speed by the following formula, and judge whether the misfire occurs or not comparing the calculated result with judgment value. Counting the number of misfire up, and if the misfire ratio is higher during 1000 rev. or 200 rev., judge NG for the corresponding cylinder.

Calculate the diagnostic value (from crankshaft position speed)

- Misfire detection every single ignition (Compare diagnostic value with judgment value)
- 180° Interval Difference Method
 - 360° Interval Difference Method
 - 720° Interval Difference Method

- NG judgment (Judge misfire occurrence required by the law) (Compare number of misfire with judgment)
- FTP1.5 times misfire NG judgment
 - Catalyst damage misfire NG judgment

As the following figure, pick out a random cylinder as the standard and name it omg 0. And the former crankshaft position speed is named omg 1, the second former crankshaft position speed is named omg 2, the third is named omg 3, and the following is the same.

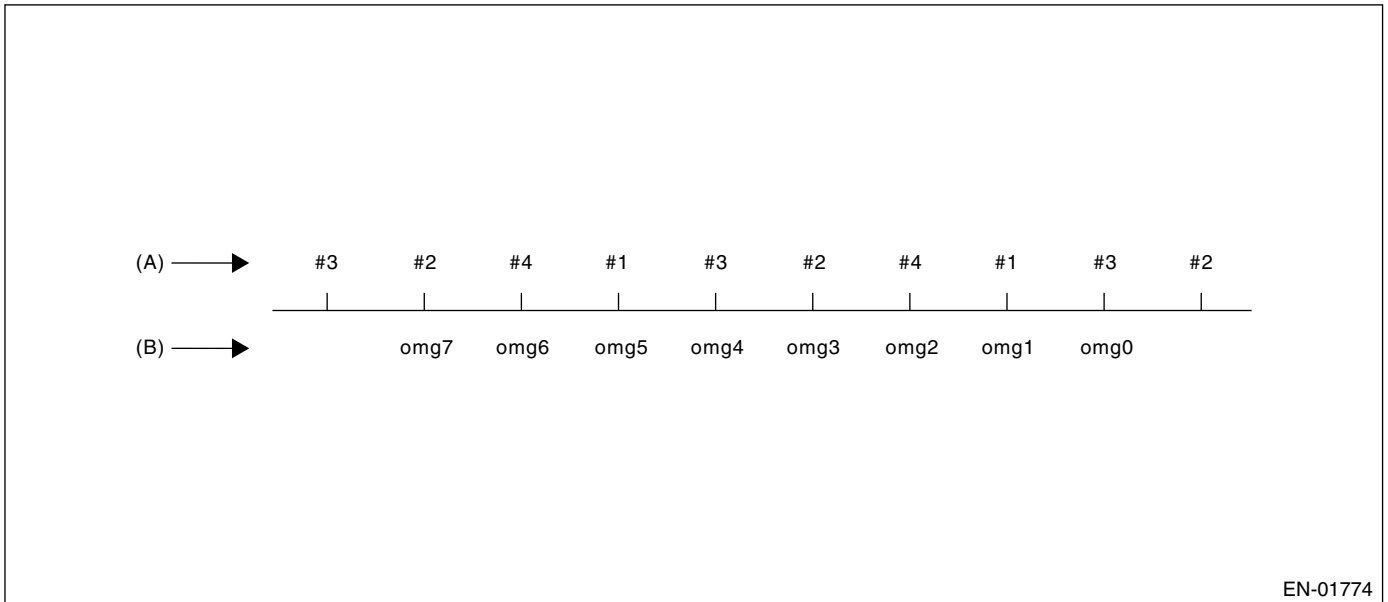

EN-01774

(A) Ignition order

(B) Crankshaft position speed

DIAGNOSTIC TROUBLE CODE (DTC) DETECTING CRITERIA

GENERAL DESCRIPTION

• 180° Interval Difference Method

Diagnosis value $\text{domg } 180 = (\text{omg } -1 \text{ omg } 0) - (\text{omg } 7 - \text{omg } 1)/6$

Judge misfire occurs in the following cases.

- $\text{domg } 180 > \text{judgment value of positive side}$
- $\text{domg } 180 \leq \text{judgment value of negative side}$
(judgment value before 180°CA)

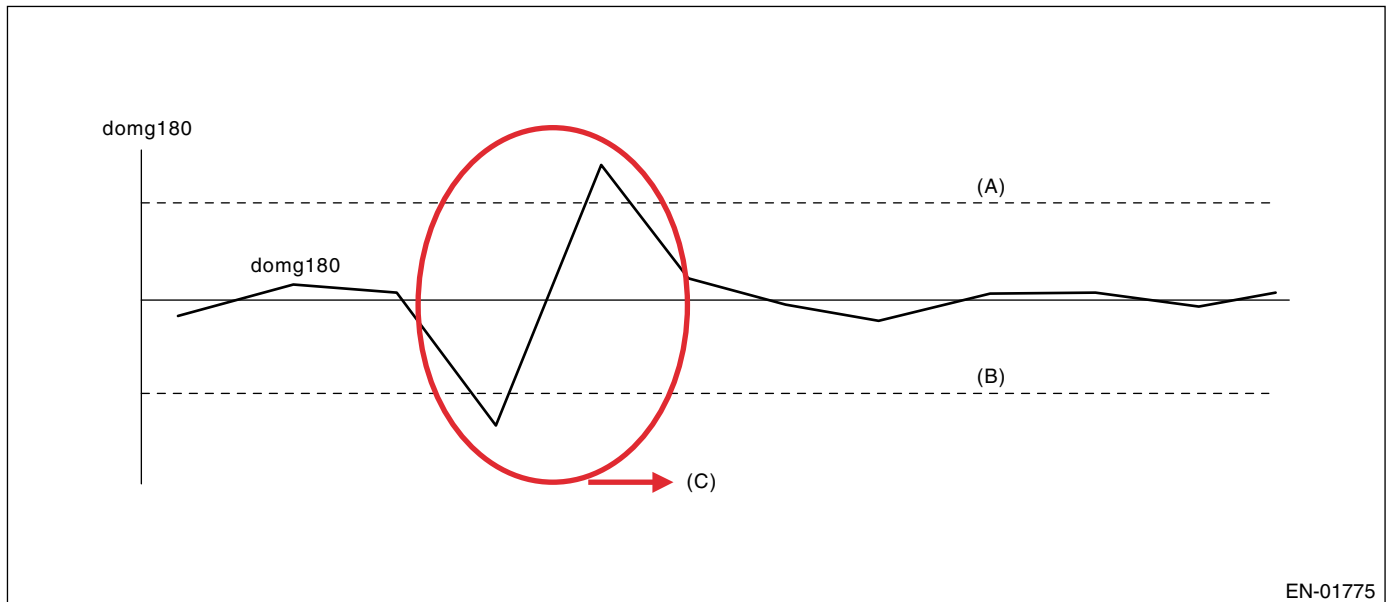

EN-01775

(A) Threshold value (positive judged value)

(B) Threshold value (negative judged value)

(C) Judged as misfire value

• 360° Interval Difference Method

Diagnosis value $\text{domg } 360 = (\text{omg } 1 - \text{omg } 0) - (\text{omg } 4 - \text{omg } 3)$

Misfire judgment $\text{domg } 360 > \text{judgment value} \rightarrow \text{Misfire occurs}$

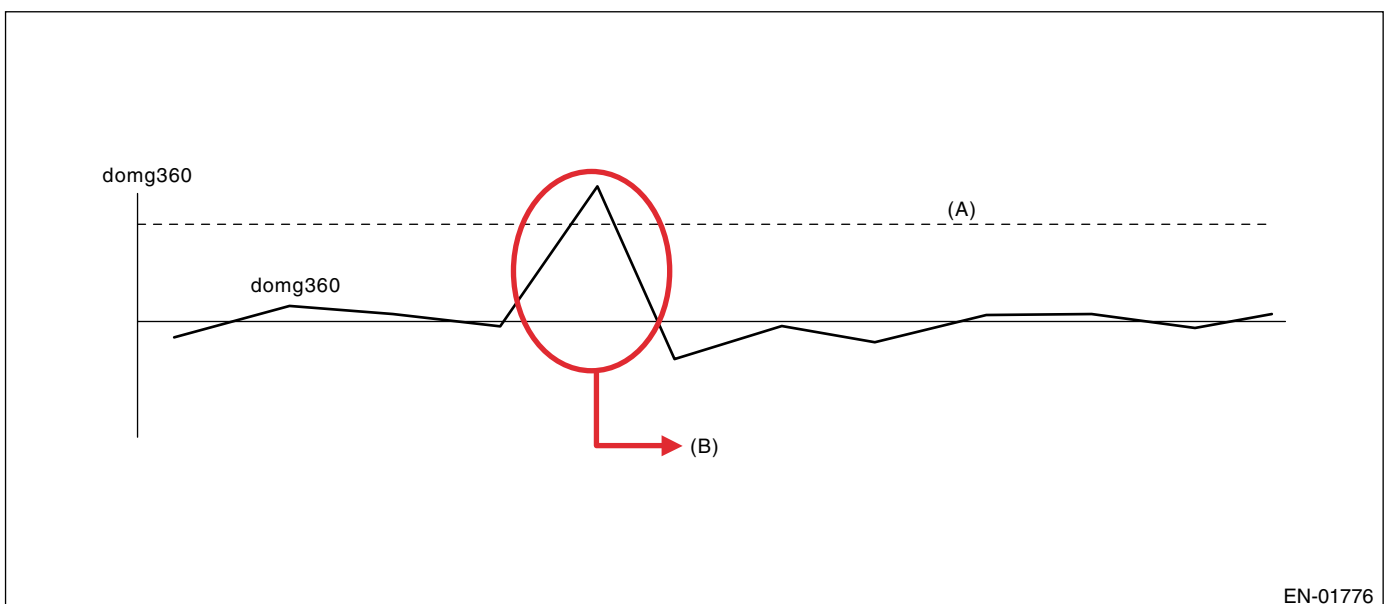

EN-01776

(A) Threshold value

(B) Judged as misfire

DIAGNOSTIC TROUBLE CODE (DTC) DETECTING CRITERIA

GENERAL DESCRIPTION

• 720° Interval Difference Method

Diagnosis value $domg\ 720 = (omg\ 1 - omg\ 0) - (omg\ 7 - omg\ 6)$

Misfire judgment $domg\ 720 > \text{judgment value} \rightarrow \text{Misfire occurs}$

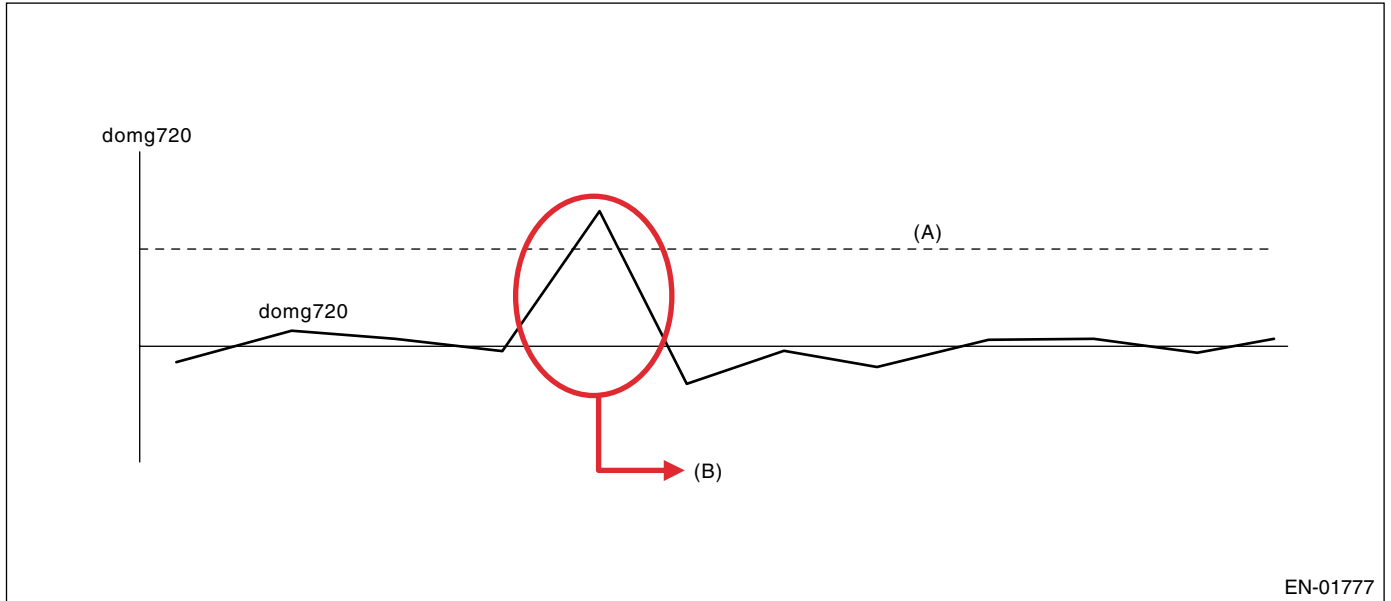

(A) Threshold value

(B) Judged as misfire

• FTP 1.5 times misfire (Misfire occurrence level affecting exhaust gas)

• Judgment Value (Judge that malfunction occurs when the misfire ratio is high in 1000 engine revs.)

Malfunction Criteria	Threshold Value
FTP emission judgment value	> 1.0% in 1000 revs.

Time Needed for Diagnosis: 1000 engine revs.

Malfunction Indicator Light Illumination: Illuminates when malfunction occurs in 2 continuous driving cycles.

• Catalyst damage misfire (Misfire occurrence level damaging catalyst)

• Judgment Value (Judge that malfunction occurs when the misfire ratio is high in 200 engine revs. (400 ignitions))

Malfunction Criteria	Threshold Value
Catalyst damage misfire judgment value	See Map 1

DIAGNOSTIC TROUBLE CODE (DTC) DETECTING CRITERIA

GENERAL DESCRIPTION

Map 1 Fault criteria threshold for misfire which would result in catalytic damage

percentage	Intake air (g (oz)/gev.)										
	0.2 (0.007)	0.4 (0.014)	0.6 (0.021)	0.8 (0.028)	1.0 (0.035)	1.2 (0.042)	1.4 (0.049)	1.6 (0.056)	1.8 (0.063)	2.0 (0.071)	
Engine speed (rpm)	1000	37.0	32.0	28.5	26.0	23.0	21.3	21.3	—	—	—
	1500	35.0	29.5	25.5	22.5	21.3	21.3	21.3	18.0	—	—
	2000	32.0	22.5	22.5	18.3	14.5	10.8	10.0	9.0	8.0	5.0
	2500	29.0	21.8	14.3	11.3	9.8	9.0	8.5	8.0	7.5	5.0
	3000	27.0	21.8	14.5	9.8	9.0	9.0	8.0	7.5	7.0	5.0
	3500	24.5	18.5	10.8	6.8	5.8	5.5	5.0	5.0	5.0	5.0
	4000	—	15.3	10.0	6.8	5.5	5.0	5.0	5.0	5.0	5.0
	4500	—	13.8	8.5	6.3	5.0	5.0	5.0	5.0	5.0	—
	5000	—	13.8	8.5	5.8	5.0	5.0	5.0	5.0	5.0	—
	5500	—	13.5	8.3	5.5	5.0	5.0	5.0	5.0	5.0	—
	6000	—	13.0	8.0	5.3	5.0	5.0	5.0	5.0	5.0	—
	6500	—	12.5	7.5	5.0	5.0	5.0	5.0	5.0	—	—
6700	—	12.3	7.3	5.0	5.0	5.0	5.0	5.0	—	—	

These figures mean the misfire ratio (%) in 400 ignitions; for example, 22.5 (%) means 400 (ignition) × 22.5 (%) = 90 (ignition) or more, so this case is judged misfire.

Time Needed for Diagnosis: 200 engine revs.

Malfunction Indicator Light Illumination: Illuminates as soon as the malfunction occurs.

5. DTC CLEAR CONDITION

- When the OK idling cycle was completed 40 times in a row
- When "Clear Memory" was performed

6. MALFUNCTION INDICATOR LIGHT CLEAR CONDITION

- When the OK driving cycle was completed 3 consecutive times.
- When "Clear Memory" was performed

7. FAIL SAFE

None

8. ECM OPERATING AT DTC SETTING

Memorize the freeze frame data. (For test mode \$02)

DIAGNOSTIC TROUBLE CODE (DTC) DETECTING CRITERIA

GENERAL DESCRIPTION

AQ:DTC P0302 — CYLINDER 2 MISFIRE DETECTED —

NOTE:

For the diagnostic procedure, refer to DTC P0301. <Ref. to GD(H4DOTC)-104, DTC P0301 — CYLINDER 1 MISFIRE DETECTED —.>

AR:DTC P0303 — CYLINDER 3 MISFIRE DETECTED —

NOTE:

For the diagnostic procedure, refer to DTC P0301. <Ref. to GD(H4DOTC)-104, DTC P0301 — CYLINDER 1 MISFIRE DETECTED —.>

AS:DTC P0304 — CYLINDER 4 MISFIRE DETECTED —

NOTE:

For the diagnostic procedure, refer to DTC P0301. <Ref. to GD(H4DOTC)-104, DTC P0301 — CYLINDER 1 MISFIRE DETECTED —.>

DIAGNOSTIC TROUBLE CODE (DTC) DETECTING CRITERIA

GENERAL DESCRIPTION

MEMO:

DIAGNOSTIC TROUBLE CODE (DTC) DETECTING CRITERIA

GENERAL DESCRIPTION

AT:DTC P0327 — KNOCK SENSOR 1 CIRCUIT LOW INPUT (BANK 1 OR SINGLE SENSOR) —

1. OUTLINE OF DIAGNOSIS

Detect the open or short circuit of the knock sensor. Judge NG when out of the standard value.

2. COMPONENT DESCRIPTION

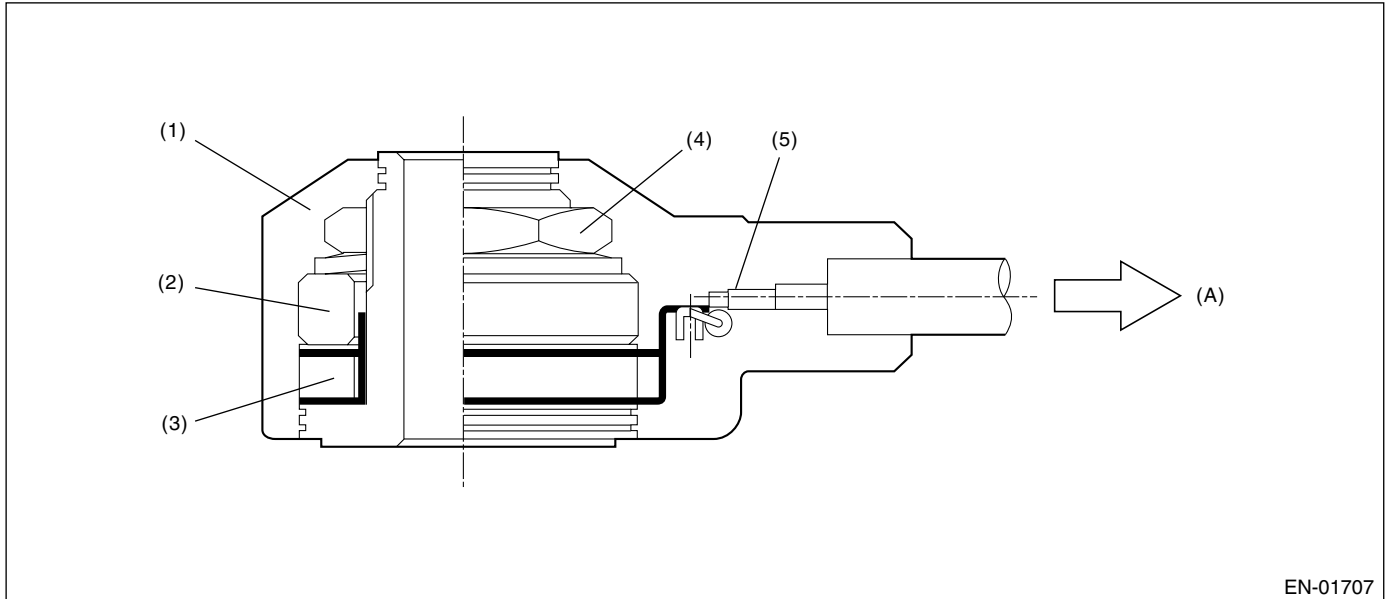

- (1) Case
- (2) Weight
- (3) Piezoelectric element

- (4) Nut
- (5) Resistance

- (A) To knock sensor harness

3. ENABLE CONDITION

Secondary Parameters	Enable Conditions
None	

4. GENERAL DRIVING CYCLE

Always perform the diagnosis continuously.

DIAGNOSTIC TROUBLE CODE (DTC) DETECTING CRITERIA

GENERAL DESCRIPTION

5. DIAGNOSTIC METHOD

• Abnormality Judgment

Judge NG when the continuous time of completing the malfunction criteria below becomes more than 1 second.

• Judgment Value

Malfunction Criteria	Threshold Value
Output voltage	< 0.238 V
Ignition switch	ON

Time Needed for Diagnosis: 1 second

Malfunction Indicator Light Illumination: Illuminates as soon as the malfunction occurs.

• Normality Judgment

Judge OK and clear NG when the malfunction criteria below are completed.

• Judgment Value

Malfunction Criteria	Threshold Value
Output voltage	≥ 0.238 V
Ignition switch	ON

6. DTC CLEAR CONDITION

- When the OK idling cycle was completed 40 times in a row
- When "Clear Memory" was performed

7. MALFUNCTION INDICATOR LIGHT CLEAR CONDITION

- When the OK driving cycle was completed 3 times in a row
- When "Clear Memory" was performed

8. FAIL SAFE

Knock compensation:

- Knock compensation final timing advance and retard value = knock compensation + whole learning compensation value + partial learning compensation value.
- At normal: knock compensation = 0°CA is fixed.
- At trouble: knock compensation = -5°CA. (Retard 5°CA.)
- Not allowed to update the whole learning compensation factor.
- Not allowed to calculate the partial learning zone compensation value.

9. ECM OPERATING AT DTC SETTING

Memorize the freeze frame data. (For test mode \$02)

DIAGNOSTIC TROUBLE CODE (DTC) DETECTING CRITERIA

GENERAL DESCRIPTION

AU:DTC P0328 — KNOCK SENSOR 1 CIRCUIT HIGH INPUT (BANK 1 OR SINGLE SENSOR) —

1. OUTLINE OF DIAGNOSIS

Detect the open or short circuit of the knock sensor. Judge NG when out of the standard value.

2. COMPONENT DESCRIPTION

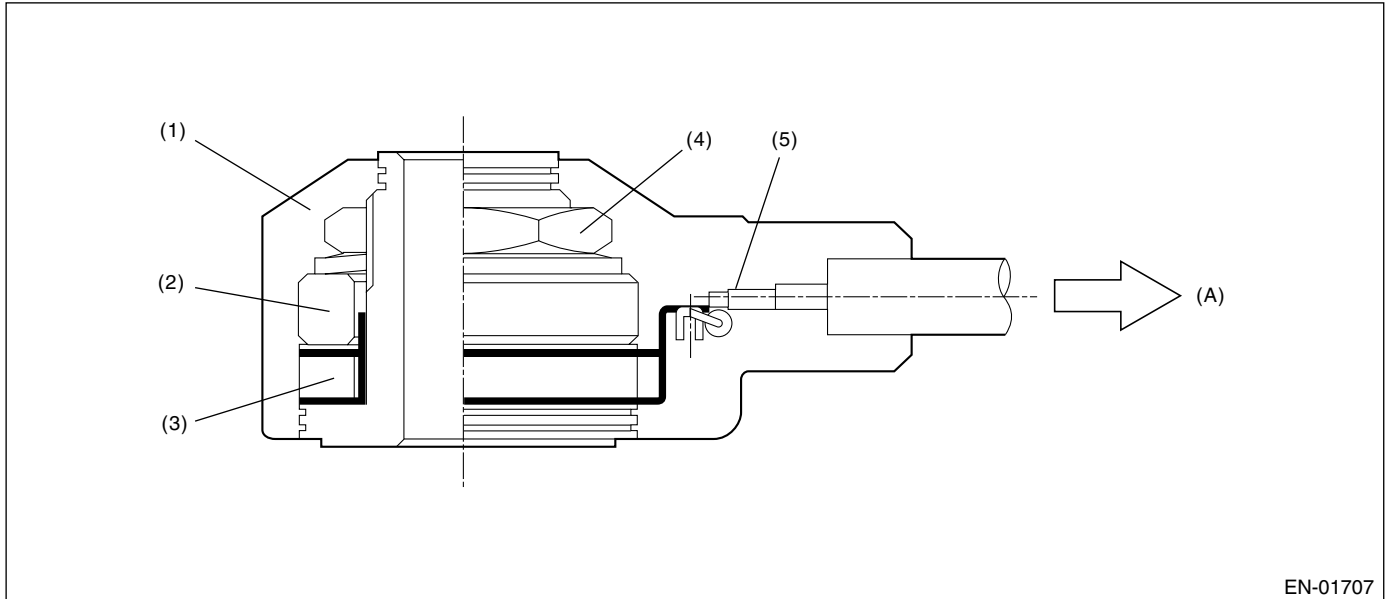

- (1) Case
- (2) Weight
- (3) Piezoelectric element

- (4) Nut
- (5) Resistance

- (A) To knock sensor harness

3. ENABLE CONDITION

Secondary Parameters	Enable Conditions
None	

4. GENERAL DRIVING CYCLE

Always perform diagnosis continuously.

DIAGNOSTIC TROUBLE CODE (DTC) DETECTING CRITERIA

GENERAL DESCRIPTION

5. DIAGNOSTIC METHOD

• Abnormality Judgment

Judge NG when the continuous time of completing the malfunction criteria below becomes more than 1 second.

• Judgment Value

Malfunction Criteria	Threshold Value
Output voltage	≥ 4.714 V
Ignition switch	ON

Time Needed for Diagnosis: 1 second

Malfunction Indicator Light Illumination: Illuminates as soon as the malfunction occurs.

• Normality Judgment

Judge OK and clear NG when the malfunction criteria below are completed.

• Judgment Value

Malfunction Criteria	Threshold Value
Output voltage	< 4.714 V
Ignition switch	ON

6. DTC CLEAR CONDITION

- When the OK idling cycle was completed 40 times in a row
- When "Clear Memory" was performed

7. MALFUNCTION INDICATOR LIGHT CLEAR CONDITION

- When the OK driving cycle was completed 3 times in a row
- When "Clear Memory" was performed

8. FAIL SAFE

Knock compensation:

- Knock compensation final timing advance and retard value = knock compensation + whole learning compensation value + partial learning compensation value.
- At normal: knock compensation = 0°CA is fixed.
- At trouble: knock compensation = -5°CA . (Retard 5°CA .)
- Not allowed to update the whole learning compensation factor.
- Not allowed to calculate the partial learning zone compensation value.

9. ECM OPERATING AT DTC SETTING

Memorize the freeze frame data. (For test mode \$02)

DIAGNOSTIC TROUBLE CODE (DTC) DETECTING CRITERIA

GENERAL DESCRIPTION

AV:DTC P0335 — CRANKSHAFT POSITION SENSOR “A” CIRCUIT —

1. OUTLINE OF DIAGNOSIS

Detect the open or short circuit of crankshaft position sensor. Judge NG when the crankshaft signal does not input regardless of turning the starter.

2. COMPONENT DESCRIPTION

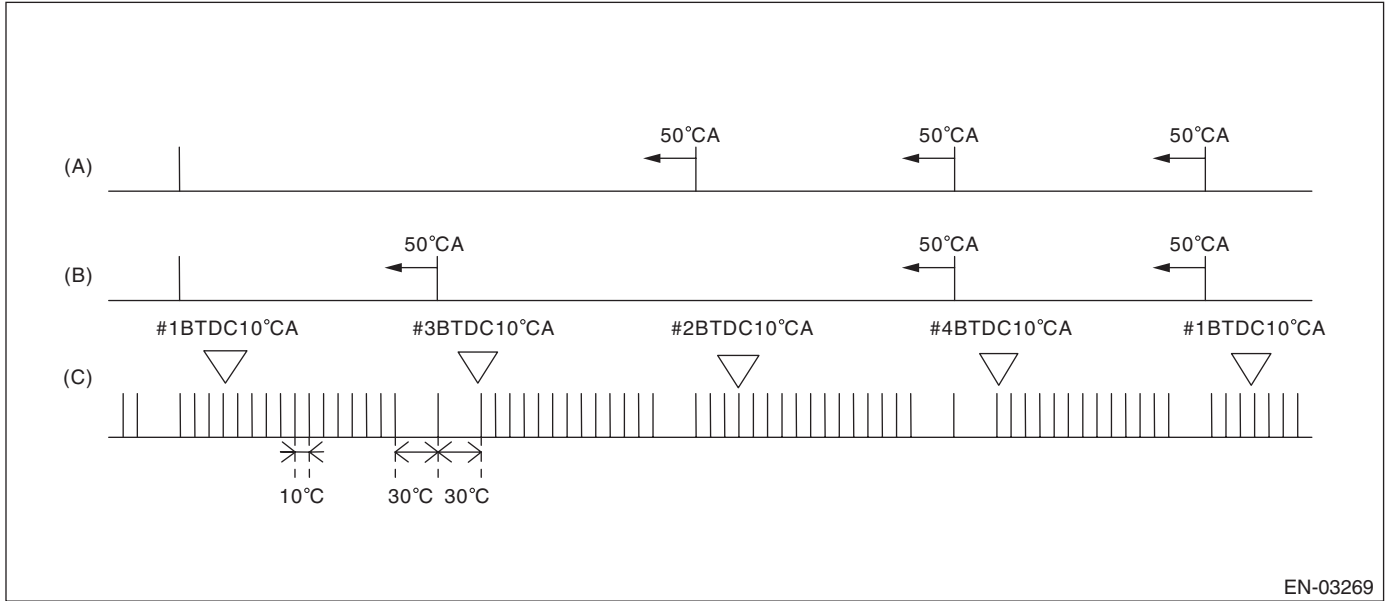

(A) Camshaft signal (RH)

(B) Camshaft signal (LH)

(C) Crankshaft signal

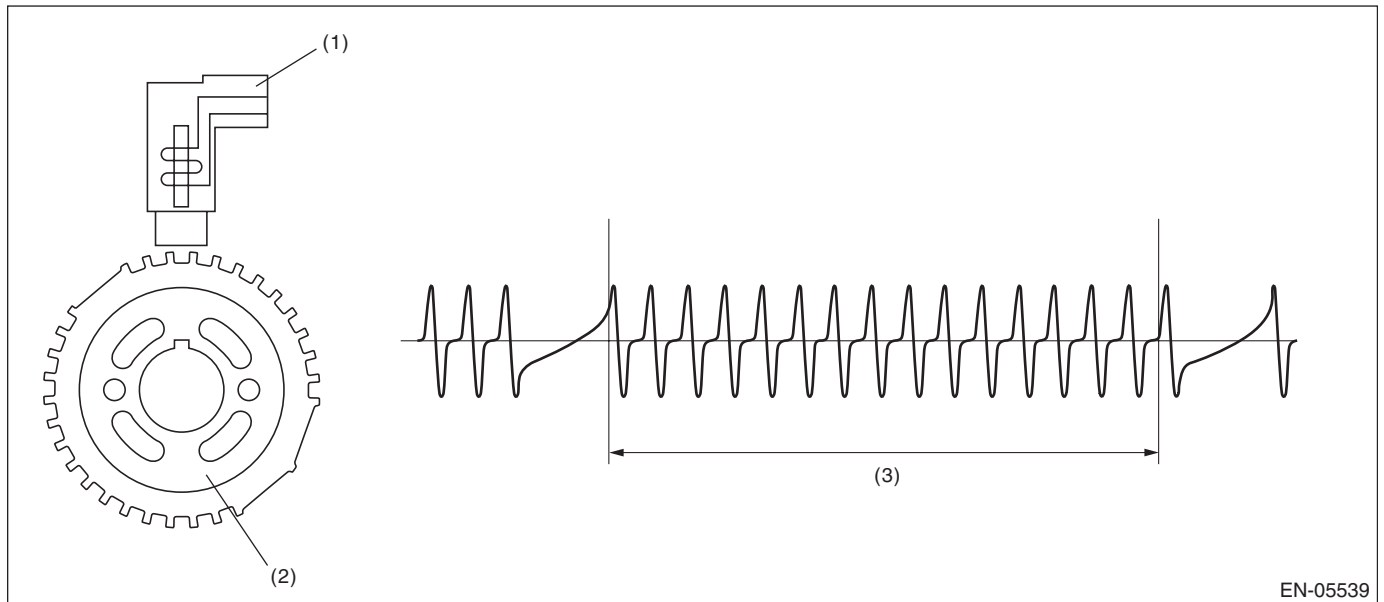

(1) Crankshaft position sensor

(2) Crankshaft sprocket
(3) Crankshaft half-turn

3. ENABLE CONDITION

Secondary Parameters	Enable Conditions
None	

DIAGNOSTIC TROUBLE CODE (DTC) DETECTING CRITERIA

GENERAL DESCRIPTION

4. GENERAL DRIVING CYCLE

Always perform the diagnosis continuously.

5. DIAGNOSTIC METHOD

• Abnormality Judgment

Judge NG when the continuous time of completing the malfunction criteria below becomes more than 3 seconds.

• Judgment Value

Malfunction Criteria	Threshold Value
Starter switch	ON
Crankshaft position sensor signal	Not detected
Battery voltage	≥ 8 V

Time Needed for Diagnosis: 3 seconds

Malfunction Indicator Light Illumination: Illuminates as soon as the malfunction occurs.

• Normality Judgment

Judge OK when the continuous time of completing the malfunction criteria below becomes more than 3 seconds.

• Judgment Value

Malfunction Criteria	Threshold Value
Crankshaft position sensor signal	Input exists
Battery voltage	≥ 8 V

6. DTC CLEAR CONDITION

- When the OK idling cycle was completed 40 times in a row
- When "Clear Memory" was performed

7. MALFUNCTION INDICATOR LIGHT CLEAR CONDITION

- When the OK driving cycle was completed 3 times in a row
- When "Clear Memory" was performed

8. FAIL SAFE

None

9. ECM OPERATING AT DTC SETTING

Memorize the freeze frame data. (For test mode \$02)

DIAGNOSTIC TROUBLE CODE (DTC) DETECTING CRITERIA

GENERAL DESCRIPTION

AW:DTC P0336 — CRANKSHAFT POSITION SENSOR “A” CIRCUIT RANGE/ PERFORMANCE —

1. OUTLINE OF DIAGNOSIS

Detect the malfunction of crankshaft position sensor output property. Judge NG when the number of crankshaft signal every 1 revolution becomes abnormal.

2. COMPONENT DESCRIPTION

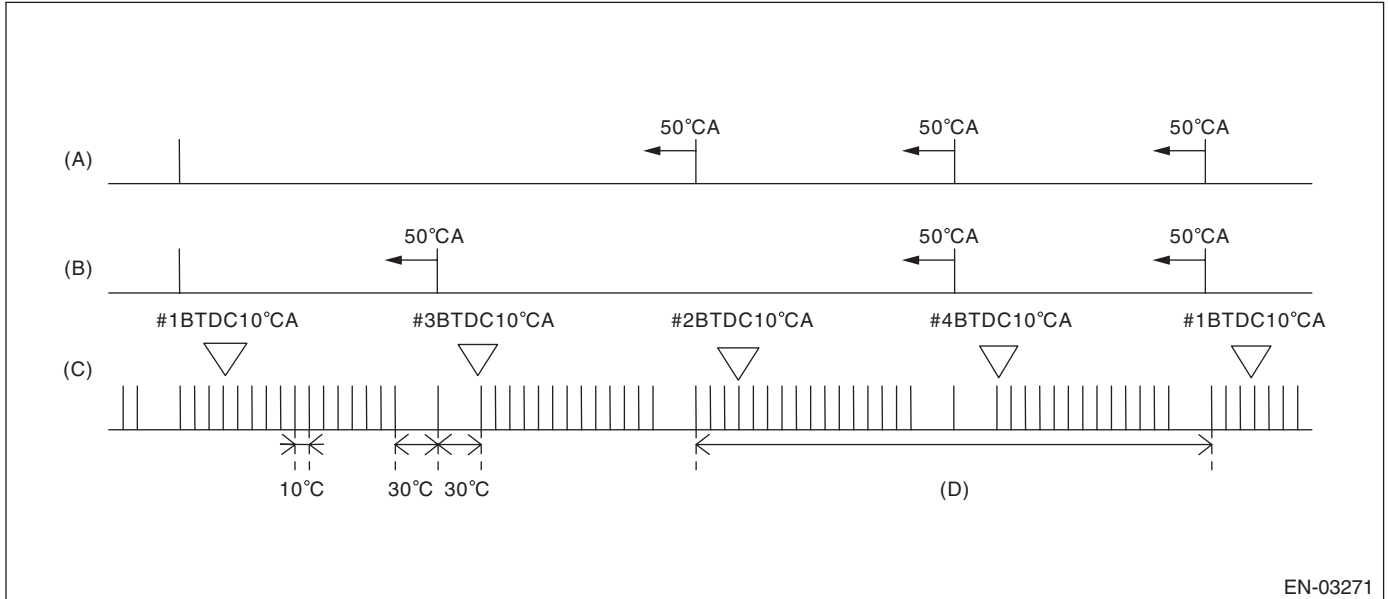

(A) Camshaft signal (RH)

(C) Crankshaft signal

(D) Number of crankshaft signal = 30 is normal.

(B) Camshaft signal (LH)

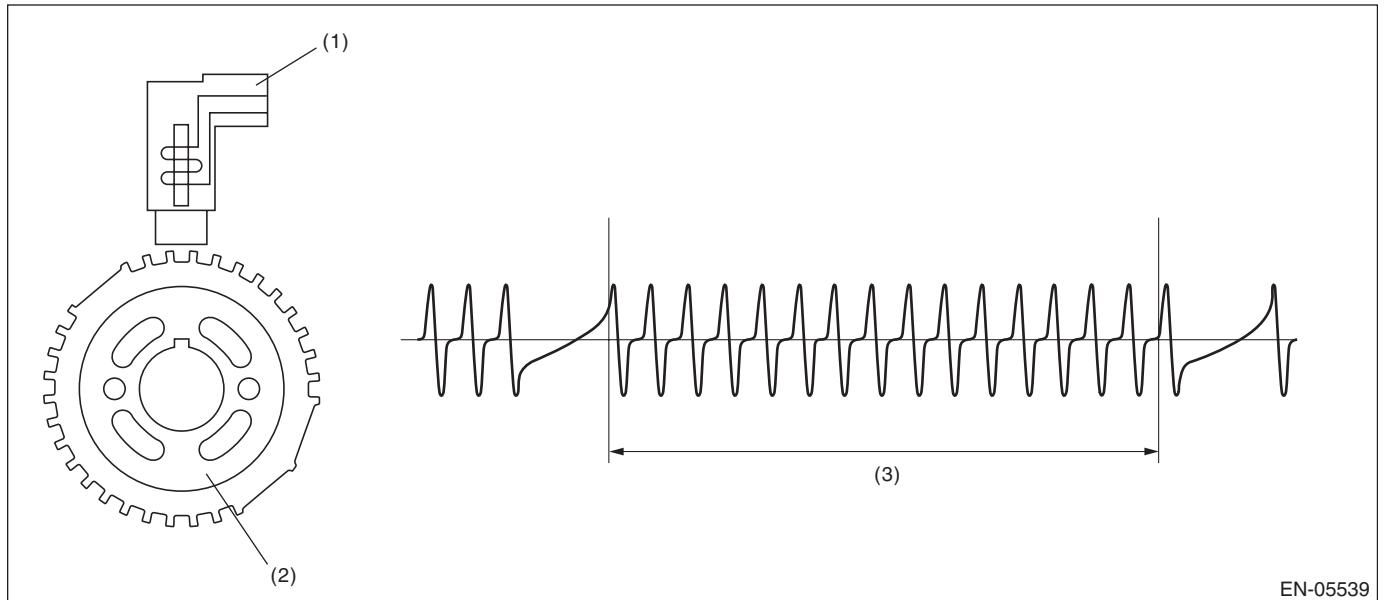

(1) Crankshaft position sensor

(2) Crankshaft sprocket

(3) Crankshaft half-turn

DIAGNOSTIC TROUBLE CODE (DTC) DETECTING CRITERIA

GENERAL DESCRIPTION

3. ENABLE CONDITION

Secondary Parameters	Enable Conditions
Battery voltage	$\geq 8\text{ V}$
Engine speed	$< 3000\text{ rpm}$

4. GENERAL DRIVING CYCLE

Perform the diagnosis continuously under 3000 rpm engine speed.

5. DIAGNOSTIC METHOD

• Abnormality Judgment

Judge NG when all the malfunction criteria below are completed more than 10 times in a row.

• Judgment Value

Malfunction Criteria	Threshold Value
Cylinder number distinction	Completed
Amount of crank sensor signal during 1 rev.	Not = 30

Time Needed for Diagnosis: 10 engine revs.

Malfunction Indicator Light Illumination: Illuminates when malfunction occurs in 2 continuous driving cycles.

• Normality Judgment

Judge OK and clear the NG when the malfunction criteria below are completed.

• Judgment Value

Malfunction Criteria	Threshold Value
Cylinder number distinction	Completed
Amount of crank sensor signal during 1 rev.	= 30

6. DTC CLEAR CONDITION

- When the OK idling cycle was completed 40 times in a row
- When "Clear Memory" was performed

7. MALFUNCTION INDICATOR LIGHT CLEAR CONDITION

- When the OK driving cycle was completed 3 times in a row
- When "Clear Memory" was performed

8. FAIL SAFE

None

9. ECM OPERATING AT DTC SETTING

Memorize the freeze frame data. (For test mode \$02)

DIAGNOSTIC TROUBLE CODE (DTC) DETECTING CRITERIA

GENERAL DESCRIPTION

AX:DTC P0340 — CAMSHAFT POSITION SENSOR “A” CIRCUIT (BANK 1 OR SINGLE SENSOR) —

1. OUTLINE OF DIAGNOSIS

Detect the open or short circuit of camshaft position sensor. Judge NG when the number of camshaft signal remains to be abnormal.

2. COMPONENT DESCRIPTION

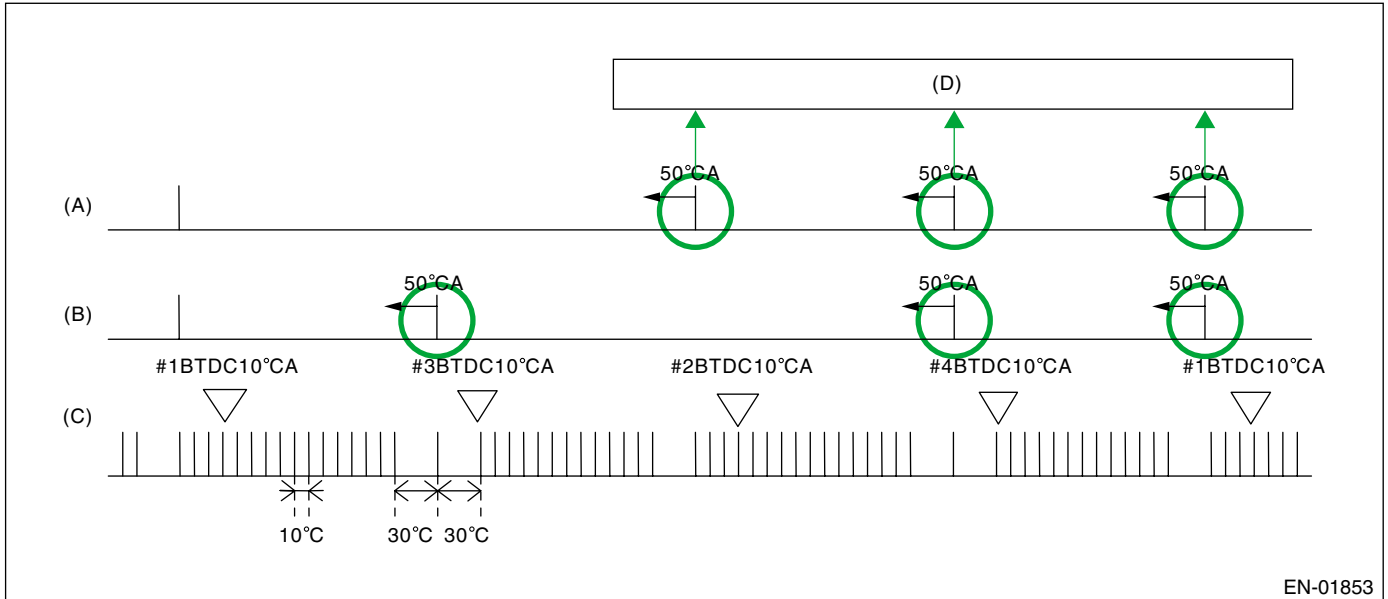

EN-01853

- (A) Camshaft signal RH
- (B) Camshaft signal LH
- (C) Crankshaft signal

- (D) Number of camshaft position signals = Receive camshaft position signal 3 times per two engine revolutions.

3. ENABLE CONDITION

Secondary Parameters	Enable Conditions
Voltage	$\geq 8 \text{ V}$
Engine speed	$\geq 600 \text{ rpm}$

4. GENERAL DRIVING CYCLE

Always perform the diagnosis continuously.

DIAGNOSTIC TROUBLE CODE (DTC) DETECTING CRITERIA

GENERAL DESCRIPTION

5. DIAGNOSTIC METHOD

• Abnormality Judgment

The camshaft signal normally enters three times by two rev. of engine speed; however, judge NG when the camshaft signal does not enter three times continuously.

Judge NG when the malfunction criteria below are completed more than 100 rev. of engine speed. Judge OK and clear NG when the malfunction criteria below are not completed.

• Judgment Value

Malfunction Criteria	Threshold Value
Number of camshaft sensor signal during 2 rev.	Except 3
Engine speed	≥ 600 rpm

Time Needed for Diagnosis: 100 rev.

Malfunction Indicator Light Illumination: Illuminates as soon as the malfunction occurs.

• Normality Judgment

Judge OK and clear the NG when the malfunction criteria below are completed.

• Judgment Value

Malfunction Criteria	Threshold Value
Camshaft angle signal	Exists

6. DTC CLEAR CONDITION

- When the OK idling cycle was completed 40 times in a row
- When "Clear Memory" was performed

7. MALFUNCTION INDICATOR LIGHT CLEAR CONDITION

- When the OK driving cycle was completed 3 times in a row
- When "Clear Memory" was performed

8. FAIL SAFE

- Ignition timing whole learning compensation:
 - Enter the initial value (whole learning compensation factor = 0.5, Variable amount of whole learning compensation factor = 0.25) to the whole learning compensation factor and variable amount of whole learning compensation factor when IG OFF, and then make the whole learning incomplete.
 - Enter the initial value (whole learning compensation factor = 0.5, Variable amount of whole learning compensation factor = 0.25) to the whole learning compensation factor and variable amount of whole learning compensation factor when making a normality judgment from abnormality judgment, and then make the whole learning incomplete.
- Ignition timing partial learning compensation:
 - Enter the initial value (0°CA) to the compensation value of partial learning zone when IG OFF.
 - Enter the initial value (0°CA) to the compensation value of partial learning zone when making a normality judgment from abnormality judgment.
- AVCS control: Most timing retard learning is not complete or most timing retard learning completion is not experienced.
- ISC feedback compensation: Do not perform the AVCS actual timing advance compensation. Make the OCV driving Duty to be the given value (9.36%).

9. ECM OPERATING AT DTC SETTING

Memorize the freeze frame data. (For test mode \$02)

DIAGNOSTIC TROUBLE CODE (DTC) DETECTING CRITERIA

GENERAL DESCRIPTION

AY:DTC P0345 — CAMSHAFT POSITION SENSOR “A” CIRCUIT (BANK 2) —

NOTE:

For diagnostic procedure, refer to DTC P0340. <Ref. to GD(H4DOTC)-120, DTC P0340 — CAMSHAFT POSITION SENSOR “A” CIRCUIT (BANK 1 OR SINGLE SENSOR) —.>

DIAGNOSTIC TROUBLE CODE (DTC) DETECTING CRITERIA

GENERAL DESCRIPTION

MEMO:

DIAGNOSTIC TROUBLE CODE (DTC) DETECTING CRITERIA

GENERAL DESCRIPTION

AZ:DTC P0420 — CATALYST SYSTEM EFFICIENCY BELOW THRESHOLD (BANK 1) —

1. OUTLINE OF DIAGNOSIS

Detect the deterioration of catalyst function.

Though the rear oxygen sensor output would change slowly with a new catalyst, the sensor output with a deteriorated catalyst becomes high and the inversion time is shortened. For this reason, the catalyst diagnosis is carried out by monitoring the rear oxygen sensor output and comparing it with the front A/F sensor output.

2. COMPONENT DESCRIPTION

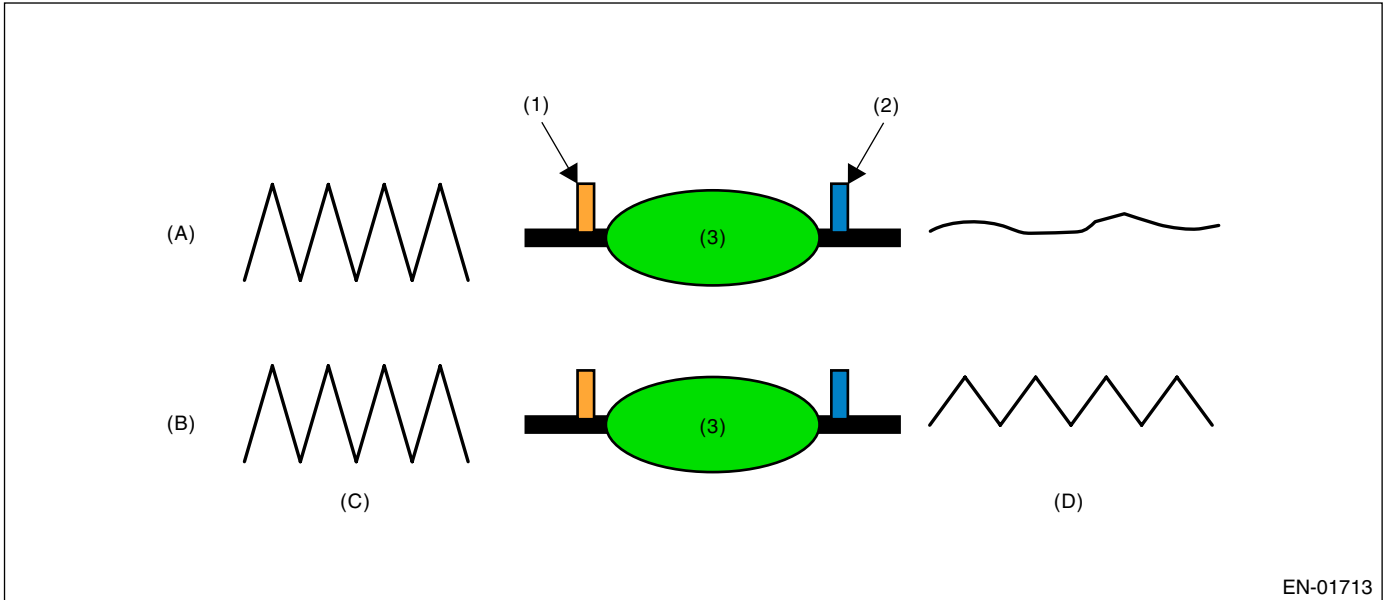

EN-01713

- (1) Front oxygen (A/F) sensor
- (2) Rear oxygen sensor
- (3) Catalyst

- (A) Normal
- (B) Deterioration

- (C) Front oxygen (A/F) sensor waveform
- (D) Rear oxygen (A/F) sensor waveform

DIAGNOSTIC TROUBLE CODE (DTC) DETECTING CRITERIA

GENERAL DESCRIPTION

3. ENABLE CONDITION

Secondary Parameters	Enable Conditions
Time for keep completing all secondary parameters	1.2 seconds or more
Battery voltage	> 10.9 V
Atmospheric pressure	> 75.1 kPa (563 mmHg, 22.2 inHg)
Engine coolant temperature	≥ 65°C (149°F)
Catalyst warm-up counter on Map 2	≥ 8000
Misfire detection during 200 engine revs.	< 5 times
Learning value of evaporation gas density	< 0.20
Sub feedback	In operation
Evaporative system diagnostic	Not in operation
Difference between actual and target time lambda < 0.10	1000 milliseconds or more
Vehicle speed	≥ 85 km/h (53 MPH)
Amount of intake air	12 — 40 g (0.35 ←→ 1.41 oz)/s
Engine load change every 0.5 engine revs.	< 0.03 g (0.001 oz)/rev
Rear O ₂ output change from below 600 mV to over	Experienced after fuel cut
After starting engine	≥ 200 seconds
Engine speed	1600 — 3500 rpm

• Map 2

Add the following value every 512 milliseconds.

• Catalyst warm-up counter ≤ 9000

Amount of intake air (g (oz)/s)	0 (0)	5 (0.18)	7.5 (0.265)	10 (0.35)	15 (0.53)	20 (0.71)	25 (0.88)	30 (1.06)	35 (1.23)	40 (1.41)	45 (1.59)	50 (1.76)
Integrated value for warm-up counter	-18	-5	3	11	25	40	57	72	87	100	100	100

• Catalyst warm-up counter > 8000

Amount of intake air (g (oz)/s)	0 (0)	5 (0.18)	7.5 (0.265)	10 (0.35)	15 (0.53)	20 (0.71)	25 (0.88)	30 (1.06)	35 (1.23)	40 (1.41)	45 (1.59)	50 (1.76)
Integrated value for warm-up counter	-8	-4	-1	3	6	8	9	11	13	14	14	14

4. GENERAL DRIVING CYCLE

Perform the diagnosis once at the constant vehicle speed of 75 km/h (46.6 MPH) or more after warming up the engine.

DIAGNOSTIC TROUBLE CODE (DTC) DETECTING CRITERIA

GENERAL DESCRIPTION

5. DIAGNOSTIC METHOD

After the malfunction criteria are completed, calculate the output fluctuation value of front oxygen (A/F) sensor and output fluctuation value of rear oxygen sensor.

Calculate the diagnosis value when the front oxygen (A/F) sensor output fluctuation value more than specified value.

Regard the A/F response properties and diagnosis value as parameters for judgment value.

Judge NG when the malfunction criteria below are completed, and judge OK when they are not completed.

Judgment Value

Malfunction Criteria	Threshold Value
Accumulated variation of output voltage of rear oxygen sensor per 32 milliseconds divided by accumulated variation of lambda of front oxygen (A/F) sensor per 32 milliseconds	≥ 7.0

Time Needed for Diagnosis: 55 seconds

Malfunction Indicator Light Illumination: Illuminates when malfunction occurs in 2 continuous driving cycles.

6. DTC CLEAR CONDITION

- When the OK idling cycle was completed 40 times in a row
- When "Clear Memory" was performed

7. MALFUNCTION INDICATOR LIGHT CLEAR CONDITION

- When the OK driving cycle was completed 3 times in a row
- When "Clear Memory" was performed

8. FAIL SAFE

None

9. ECM OPERATION AT DTC SETTING

- Memorize the freeze frame data. (For test mode \$02)
- Memorize the diagnostic value and trouble standard value. (For test mode \$06)

DIAGNOSTIC TROUBLE CODE (DTC) DETECTING CRITERIA

GENERAL DESCRIPTION

MEMO:

DIAGNOSTIC TROUBLE CODE (DTC) DETECTING CRITERIA

GENERAL DESCRIPTION

BA:DTC P0442 — EVAPORATIVE EMISSION CONTROL SYSTEM LEAK DETECTED (SMALL LEAK) —

1. OUTLINE OF DIAGNOSIS

Perform the diagnosis of leakage of fuels system and valve functions.

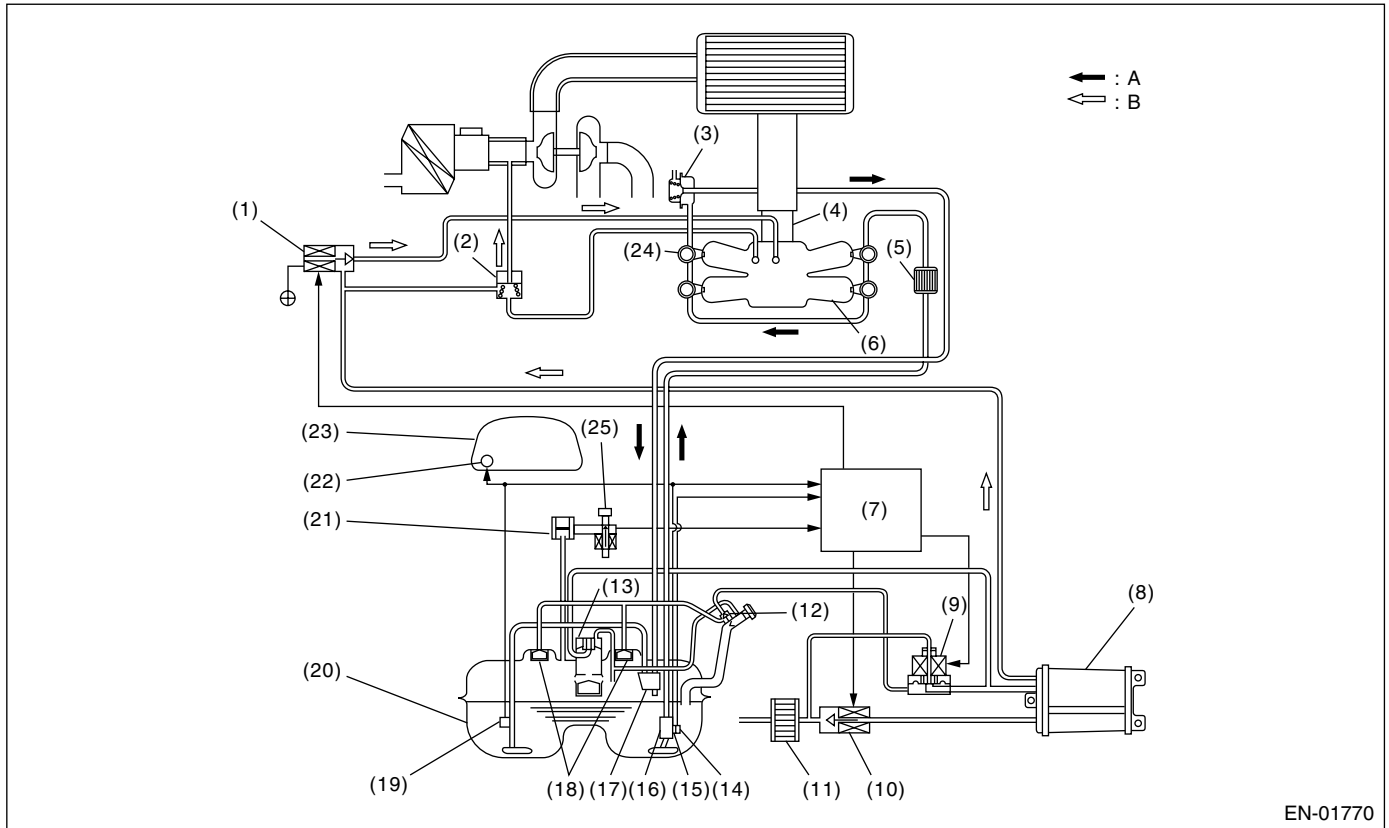

- | | | |
|-------------------------------------|------------------------------|---|
| (1) Purge control solenoid valve | (10) Drain valve | (19) Fuel sub level sensor |
| (2) Purge valve | (11) Drain filter | (20) Fuel tank |
| (3) Pressure regulator | (12) Shut-off valve | (21) Fuel tank pressure sensor |
| (4) Throttle body | (13) Vent valve | (22) Fuel meter |
| (5) Fuel filter | (14) Fuel temperature sensor | (23) Combination meter |
| (6) Intake manifold | (15) Fuel level sensor | (24) Fuel injector |
| (7) Engine control module (ECM) | (16) Fuel pump | (25) Tank pressure switching solenoid valve |
| (8) Canister | (17) Jet pump | |
| (9) Pressure control solenoid valve | (18) Fuel cut valve | |

In this system diagnosis, checking for leakage and valve function is conducted by changing the fuel tank pressure, and monitoring the pressure change using the fuel tank pressure sensor. 0.04 inch diagnosis is performed in the order of mode Z, mode A, mode B, mode C, mode D and mode E, and 0.02 inch diagnosis is performed in the order of mode Y, mode A, mode B, mode C, mode D and mode E.

DIAGNOSTIC TROUBLE CODE (DTC) DETECTING CRITERIA

GENERAL DESCRIPTION

• 0.04-inch Diagnosis

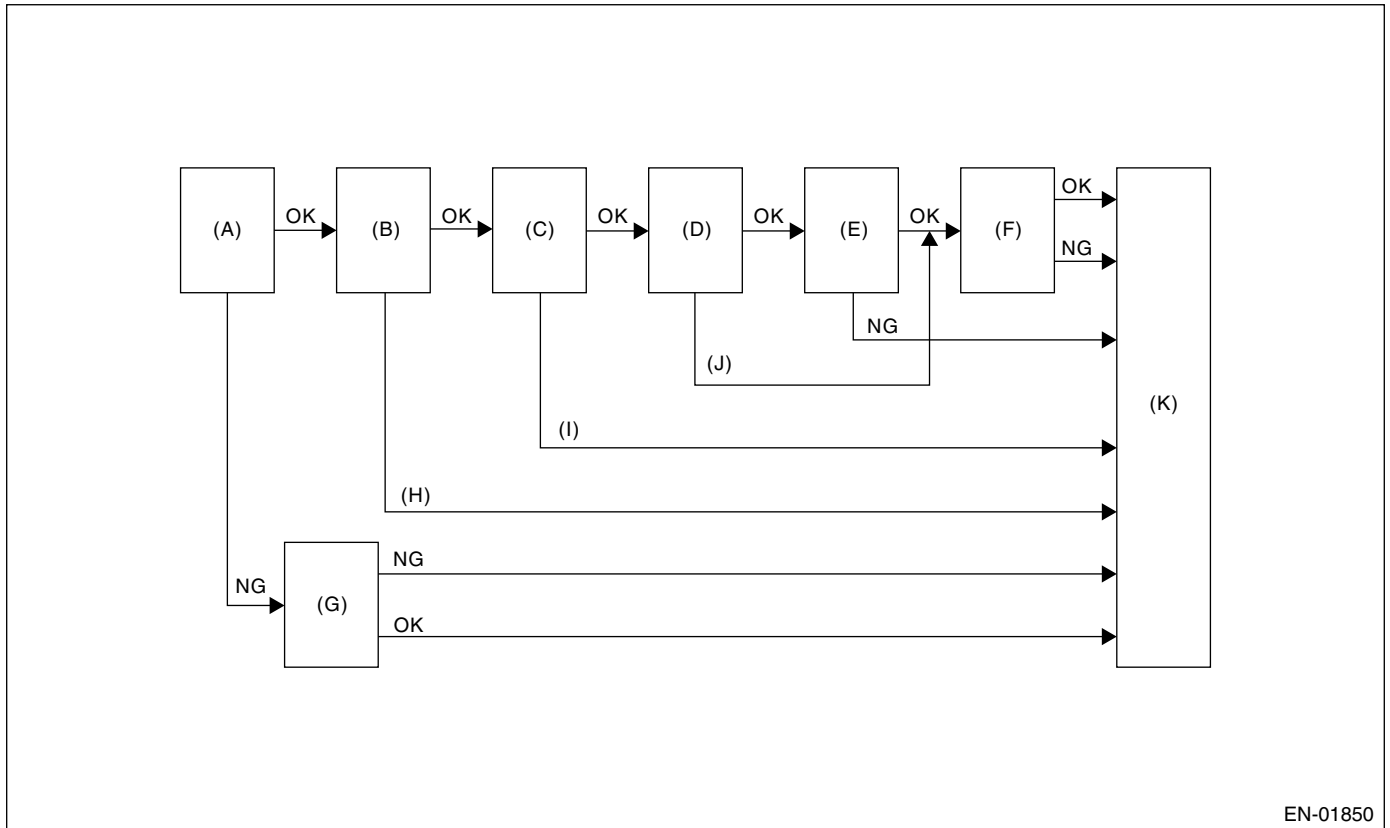

EN-01850

- | | | |
|------------|-------------------|-----------------------------|
| (A) Mode Z | (E) Mode D | (I) Large leakage diagnosis |
| (B) Mode A | (F) Mode E | (J) Quick OK judgement |
| (C) Mode B | (G) Mode Z Extend | (K) END |
| (D) Mode C | (H) Cancel | |

Mode	Mode Description	Diagnosis Period
Mode Z (CPC abnormal open diagnosis, CCV abnormal close diagnosis)	Perform CPC open stick fast and CCV close stick fast diagnosis according to tank pressure change amount after the diagnosis has started.	3 — 16 seconds
Mode A (Estimated evaporation amount)	Calculate the tank pressure change amount (P1).	16 seconds
Mode B (Sealed negative pressure, large leakage judgment)	Introduce the intake manifold pressure to the fuel tank and reduce the tank pressure to the desired value. If the tank pressure cannot be reduced, it is diagnosed as large leak.	4 — 35 seconds
Mode C (Pressure increase check advanced OK judgment)	Wait until the tank pressure becomes the desired value (detection starting pressure of P2). If the tank pressure does not become the value, make advanced OK judgment.	4 — 15 seconds
Mode D (Negative pressure variation mea- surement evaporation leakage diagnosis)	Calculate the tank pressure variation (P2), and obtain the diagnostic value using P1 of Mode 1. Perform the evaporation leakage diagnosis using the diagnostic value.	12 — 16 seconds
Mode E (CCV property abnormal diagnosis)	Perform the CCV property abnormal diagnosis according to the tank pressure change amount after the leak diagnosis has finished.	4 seconds

DIAGNOSTIC TROUBLE CODE (DTC) DETECTING CRITERIA

GENERAL DESCRIPTION

• 0.02-inch Diagnosis

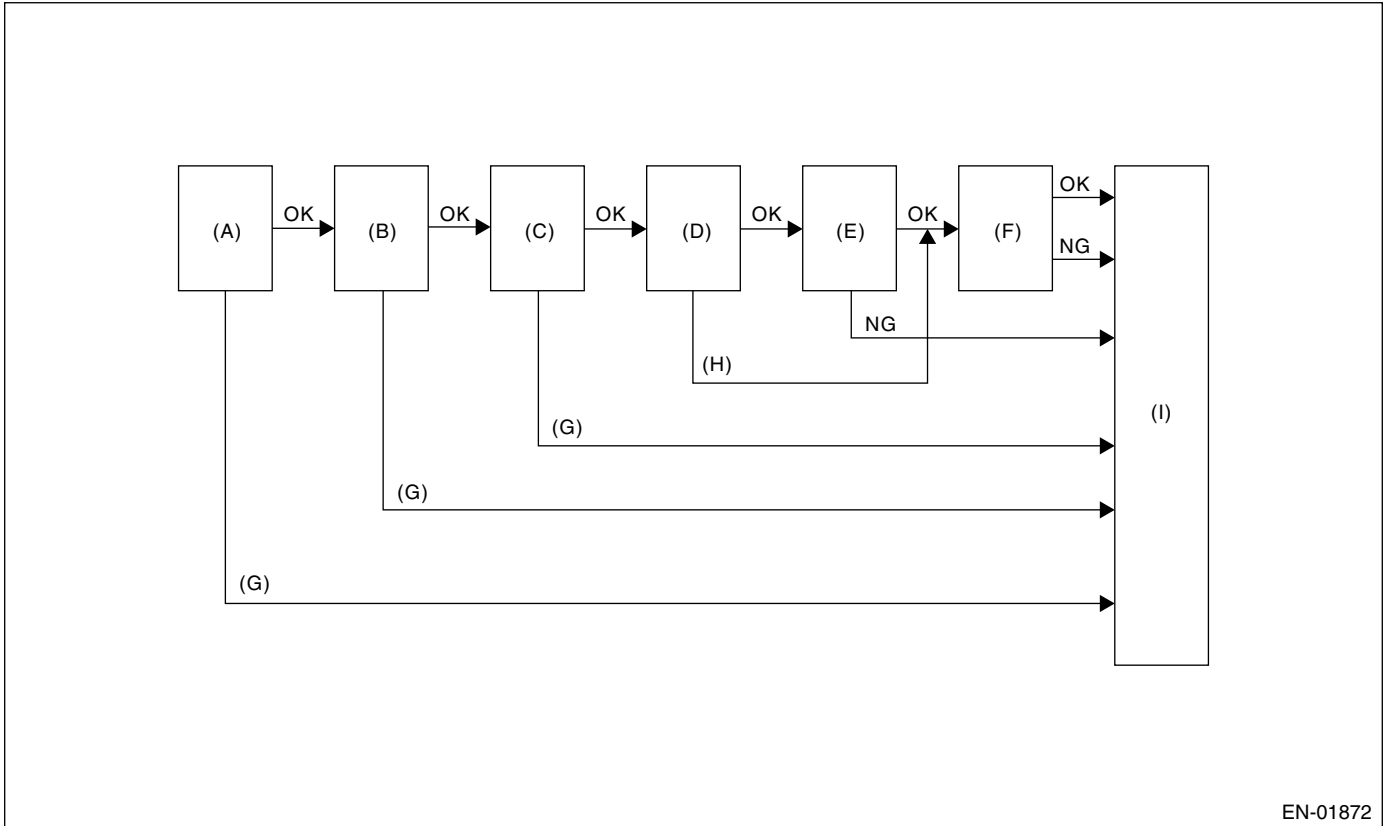

EN-01872

- | | | |
|------------|------------|------------------------|
| (A) Mode Y | (D) Mode C | (G) Cancel |
| (B) Mode A | (E) Mode D | (H) Quick OK judgement |
| (C) Mode B | (F) Mode E | (I) END |

Mode	Mode Description	Diagnosis Period
Mode Y (Tank pressure stabilization)	Return the tank pressure to atmosphere.	15 seconds
Mode A (Estimated evaporation amount)	Calculate the tank pressure change amount (P1).	29 seconds
Mode B (Negative pressure sealed)	Intake manifold pressure to the fuel tank and reduce the tank pressure to the desired value.	10 — 20 seconds
Mode C (Pressure increase check advanced OK judgement)	Wait until the tank pressure becomes the desired value (detection starting pressure of P2). If the tank pressure does not become the value, make advanced OK judgement.	5 — 20 seconds
Mode D (Negative pressure variation measurement evaporation leakage diagnosis)	Calculate the tank pressure variation (P2), and obtain the diagnostic value using P1 of Mode 1. Perform the evaporation leakage diagnosis using the diagnostic value.	20 — 25 seconds
Mode E (CCV property abnormal diagnosis)	Perform the CCV property abnormal diagnosis according to the tank pressure change amount after the leak diagnosis has finished.	4 seconds

DIAGNOSTIC TROUBLE CODE (DTC) DETECTING CRITERIA

GENERAL DESCRIPTION

• Mode Table for Evaporative Emission Control System Diagnosis

• 0.04-inch Diagnosis

Mode	Behavior of tank internal pressure under normal conditions	Diagnostic item	DTC
Mode Z	Nearly same as atmospheric pressure (equivalent pressure of 0 kPa (0 mmHg, 0 inHg))	CCV is judged to be stuck closed.	P1443
Mode A	Pressure is in proportion to amount of evaporative emission.		
Mode B	Negative pressure is formed due to intake manifold negative pressure	Large leakage	P0457
Mode C	Target pressure is reached	EVAP system is judged to have no large leak.	None
Mode D	Pressure change is small.	EVAP system is judged to have large leak [1.0 mm (0.04 in)].	P0442
Mode E	Return to atmosphere	CCV property	P1443

• 0.02-inch Diagnosis

Mode	Behavior of tank internal pressure under normal conditions	Diagnostic item	DTC
Mode Y	Return to atmosphere		
Mode A	Pressure is in proportion to amount of evaporation gas occurrence.		
Mode B	Negative pressure is formed due to intake manifold negative pressure		
Mode C	Target pressure is reached		
Mode D	Pressure change is small.	P2 measurement of small leak in system. Evaporation system is judged to have small leak [0.5 mm (0.02 in.)].	P0456
Mode E	Return to atmosphere	CCV property judgment	P1443

DIAGNOSTIC TROUBLE CODE (DTC) DETECTING CRITERIA

GENERAL DESCRIPTION

2. COMPONENT DESCRIPTION

• Pressure Control Solenoid Valve

PCV controls the fuel tank pressure to be equal to the atmospheric air pressure.

Normally, the solenoid is set to OFF. And the valve opens and closes mechanically in accordance with the pressure difference between tank and atmospheric air, or tank and canister.

Also the valve can be forcibly opened by setting the solenoid to ON.

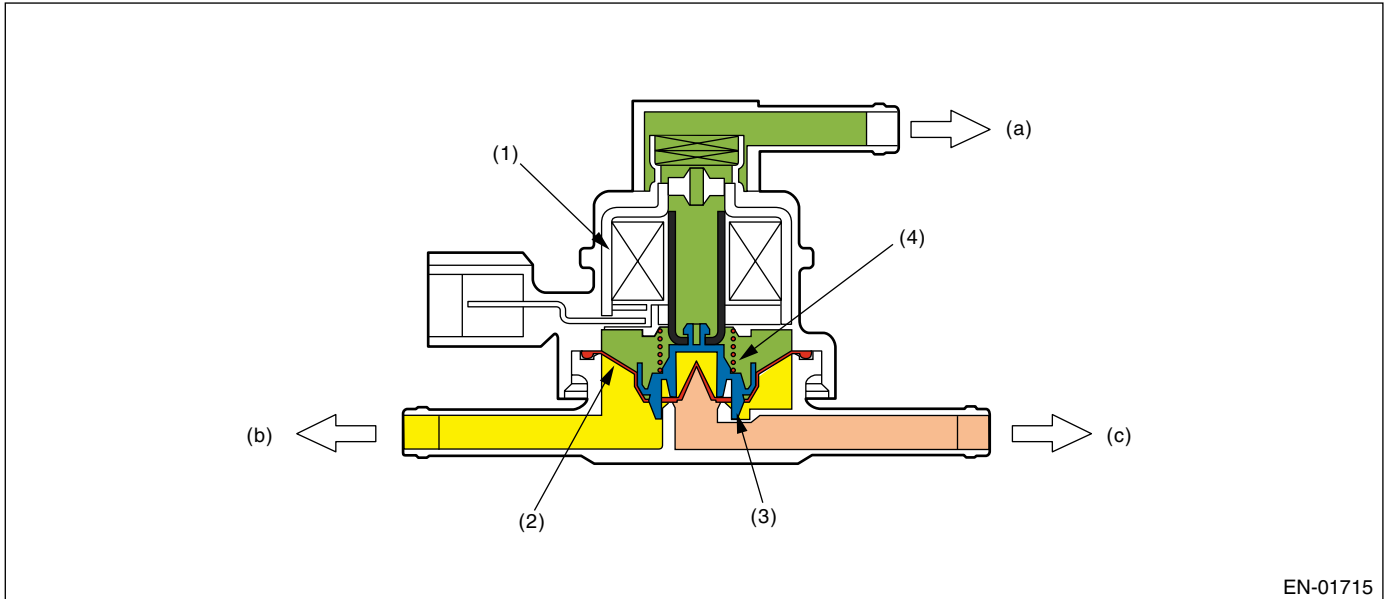

(1) Solenoid
(2) Diaphragm

(3) Valve
(4) Spring

(a) Atmospheric pressure
(b) Fuel tank
(c) Canister

DIAGNOSTIC TROUBLE CODE (DTC) DETECTING CRITERIA

GENERAL DESCRIPTION

• Valve Operation and Air Flow

In the figure below, divided by the diaphragm, the part above X is charged with atmospheric air pressure, and the part below X is charged with tank pressure. Also, the part above Y is charged with tank pressure, and the part below Y is charged with canister pressure.

If the atmospheric air pressure port is A, tank pressure port is B, and canister pressure port is C, the air flows according to pressure difference from each port as shown in the table below.

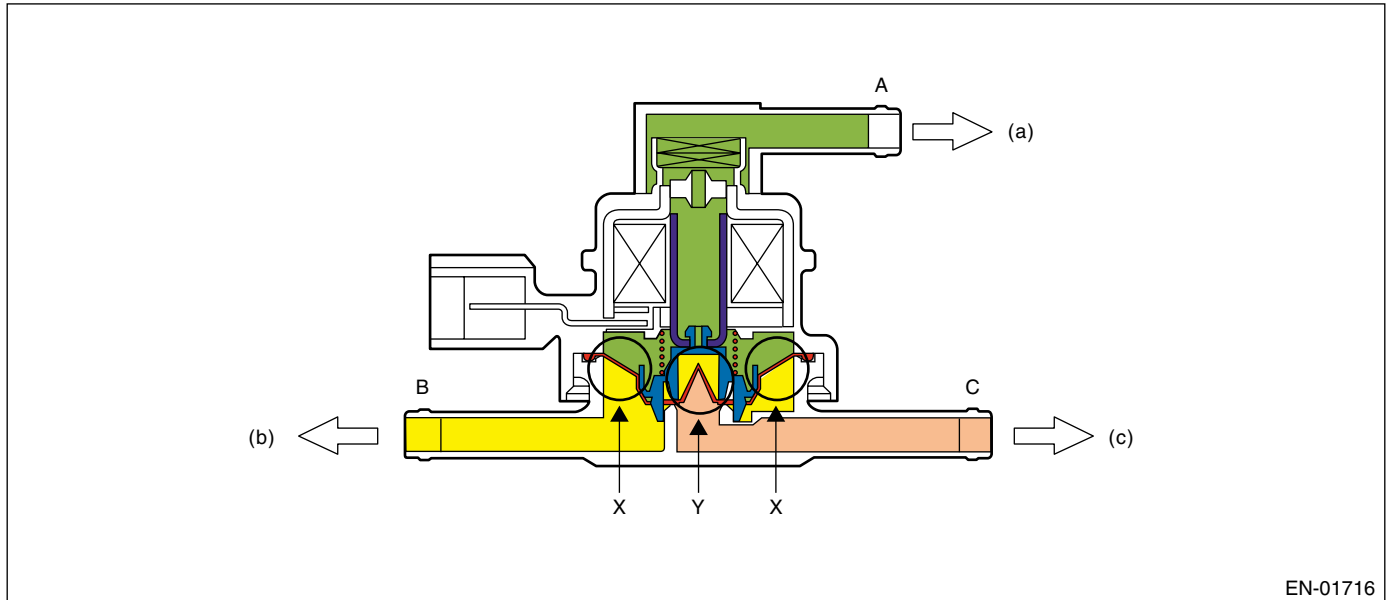

EN-01716

(a) Atmospheric pressure

(b) Fuel tank

(c) Canister

Condition of pressure	Flow
$A < B$ (solenoid OFF)	$B \rightarrow C$
$B < C$ (solenoid OFF)	$C \rightarrow B$
Solenoid ON	$B \leftrightarrow C$

• When $A < B$ (Solenoid OFF)

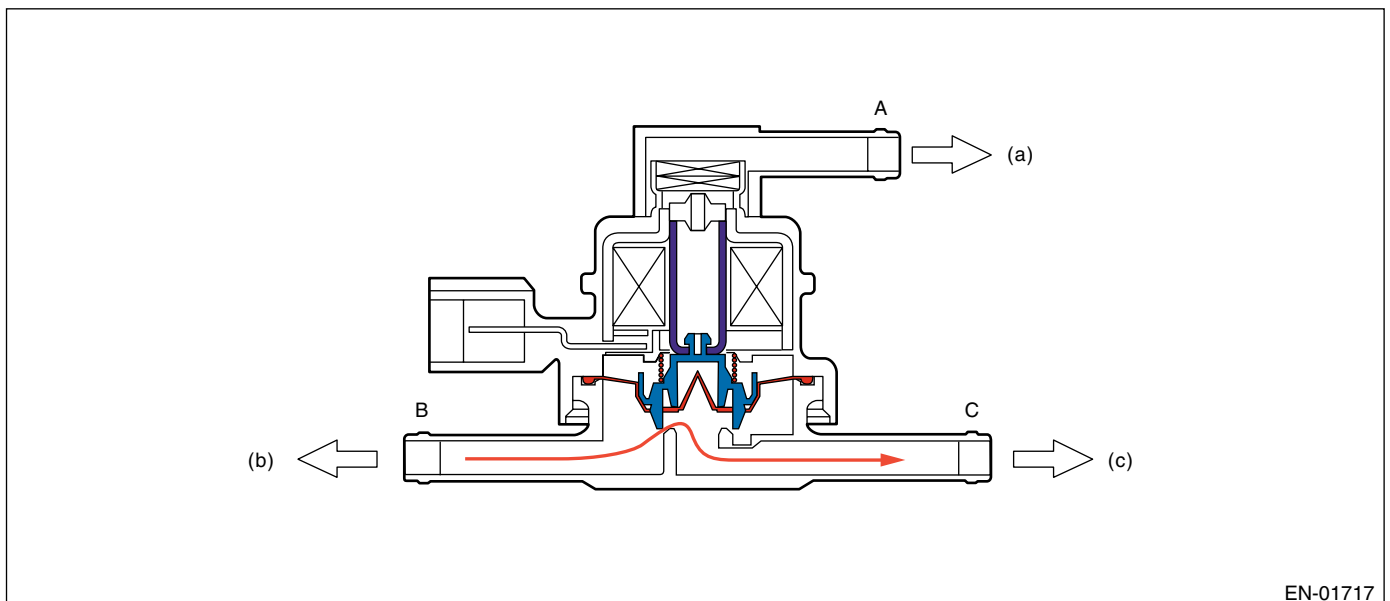

EN-01717

(a) Atmospheric pressure

(b) Fuel tank

(c) Canister

DIAGNOSTIC TROUBLE CODE (DTC) DETECTING CRITERIA

GENERAL DESCRIPTION

• When $B < C$ (Solenoid OFF)

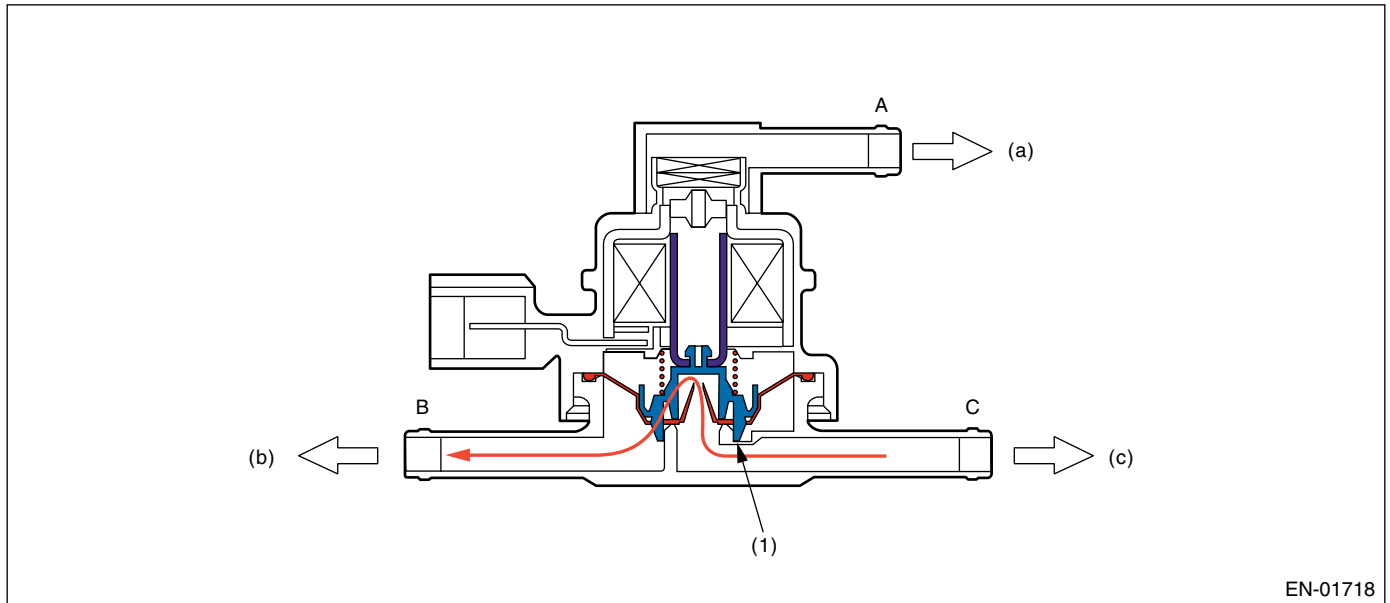

(1) Valve

(a) Atmospheric pressure

(c) Canister

(b) Fuel tank

• When Solenoid is ON

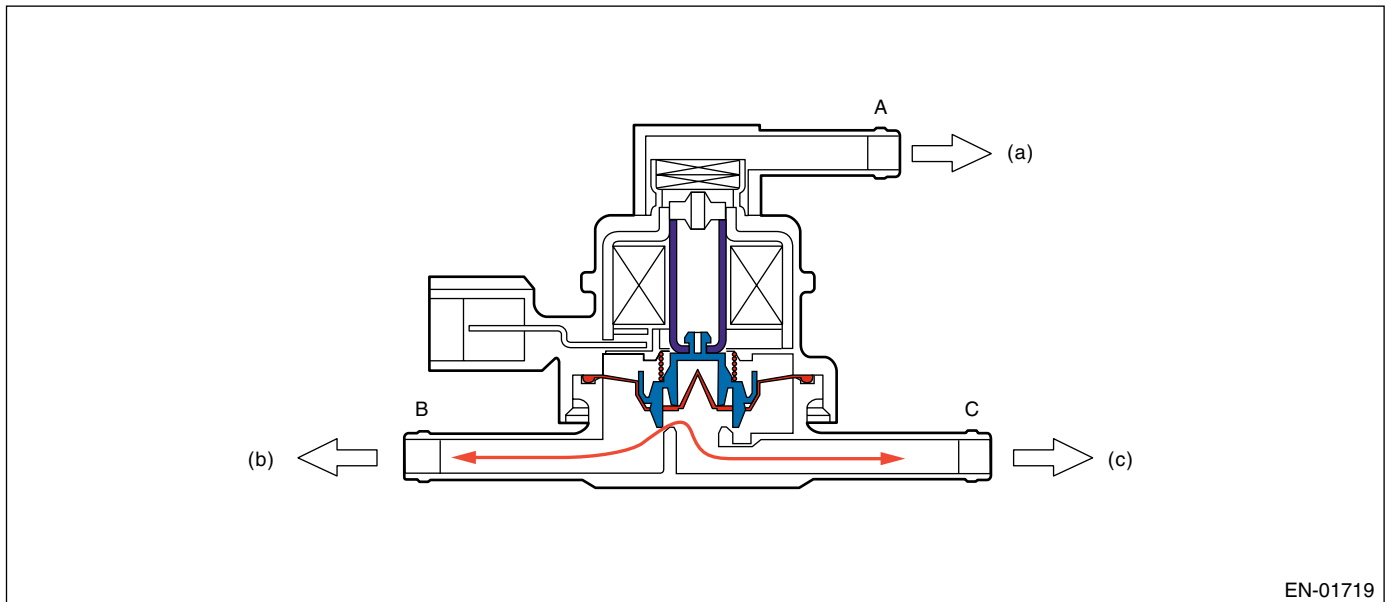

(a) Atmospheric pressure

(b) Fuel tank

(c) Canister

DIAGNOSTIC TROUBLE CODE (DTC) DETECTING CRITERIA

GENERAL DESCRIPTION

• CCV

CCV controls the ambient air to be introduced to the canister.

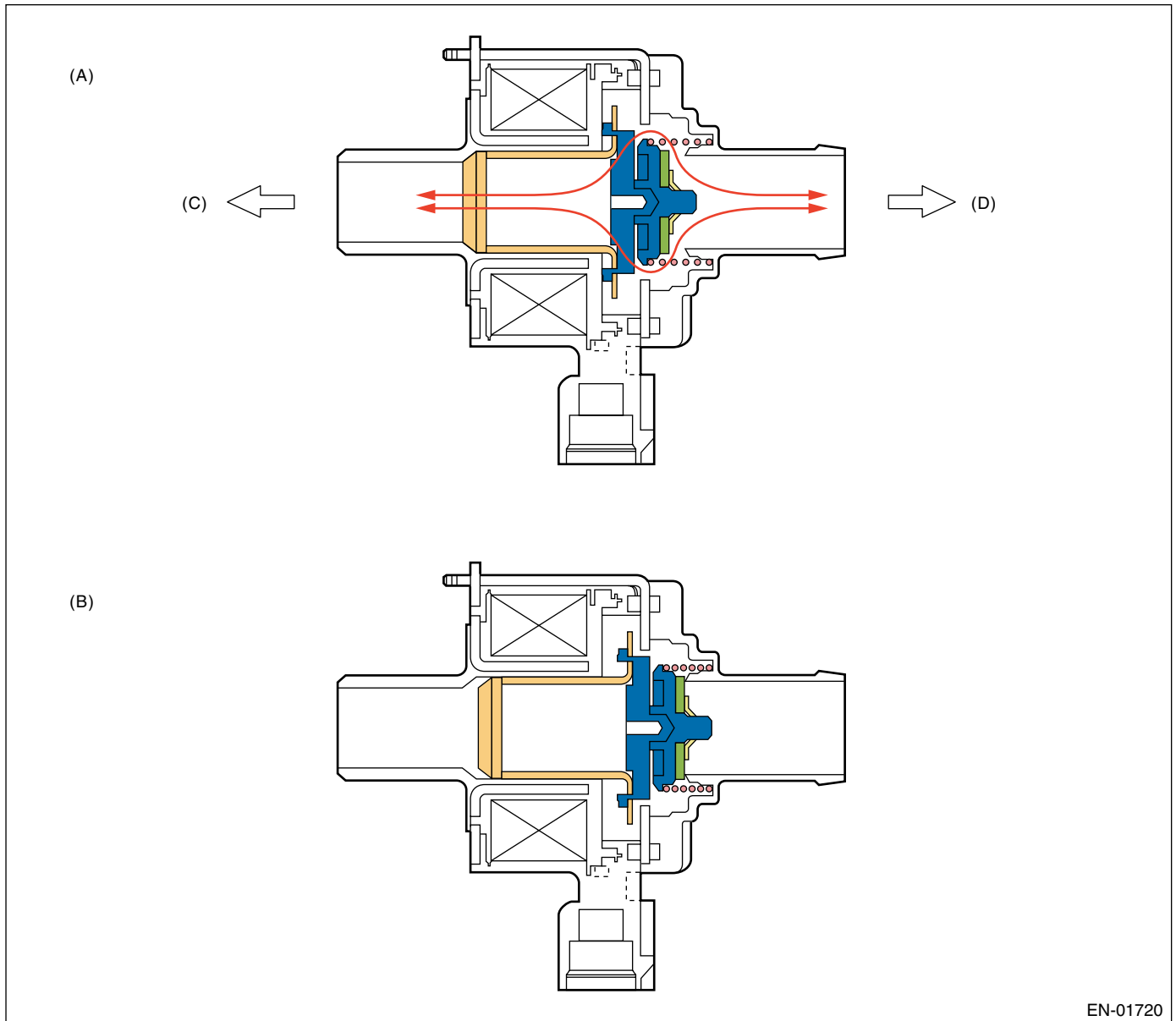

EN-01720

(A) Open (Solenoid OFF)
(B) Close (Solenoid ON)

(C) Filter
(D) Canister

DIAGNOSTIC TROUBLE CODE (DTC) DETECTING CRITERIA

GENERAL DESCRIPTION

• Tank Pressure Switching Solenoid

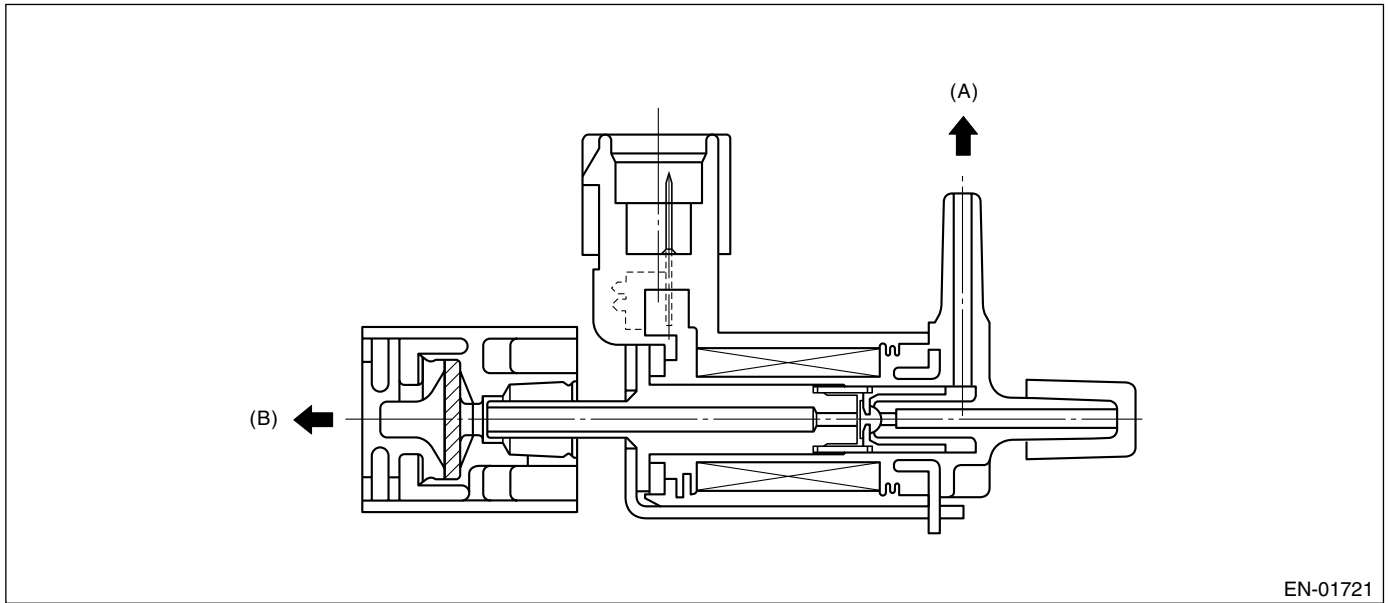

EN-01721

(A) Fuel tank pressure sensor

(B) Atmosphere

• Purpose of this solenoid

Fuel tank pressure sensor detects the difference between the atmospheric air pressure and the tank pressure and the ECM monitors the pressure difference.

Even if the tank pressure is constant, the atmospheric air pressure varies depending on the driving height, and the pressure signal transmitted to ECM will change.

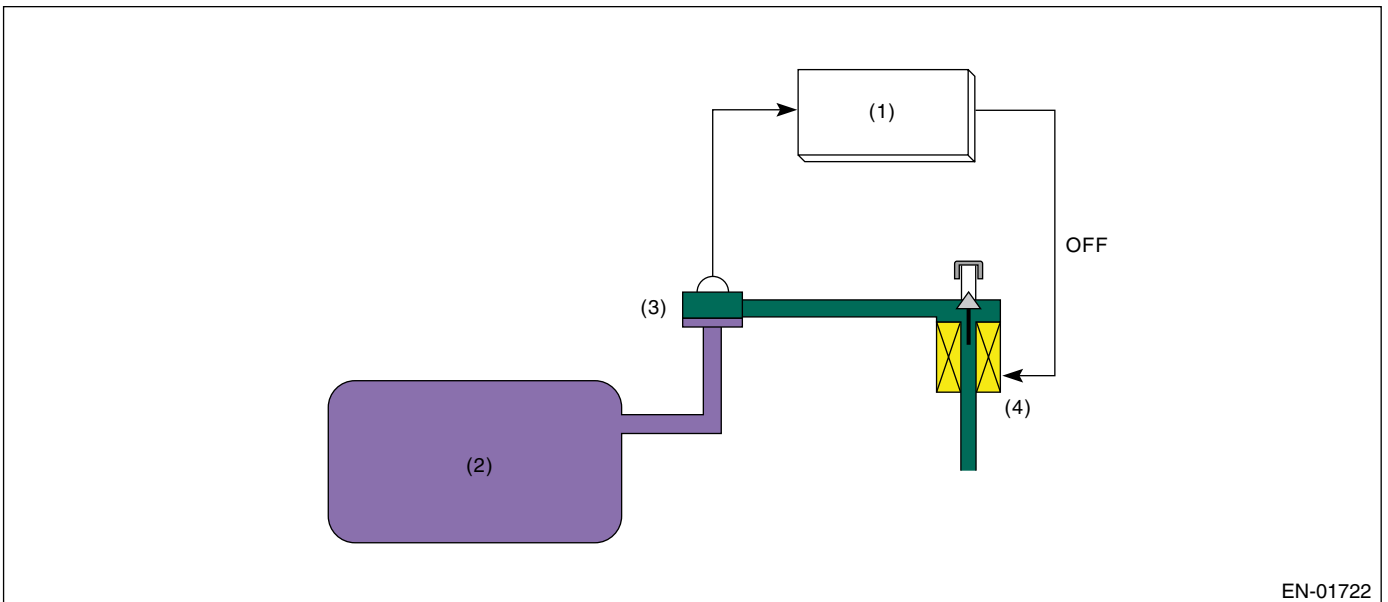

EN-01722

(1) Engine control module (ECM)

(4) Atmospheric pressure switching solenoid

(2) Fuel tank

(3) Fuel tank pressure sensor

DIAGNOSTIC TROUBLE CODE (DTC) DETECTING CRITERIA

GENERAL DESCRIPTION

Especially, in the small leakage [0.5 mm (0.02 in)], minute change in the tank pressure has to be detected. This diagnosis period is long (approx. 29 seconds). And if the driving height changes during the diagnosis, the atmospheric air pressure changes. In this case, it becomes difficult to precisely detect the tank pressure variation, causing erroneous diagnosis. Therefore, using the atmospheric pressure switching solenoid, atmospheric air is sealed between the fuel tank pressure sensor and atmospheric pressure switching solenoid, maintaining the air pressure constant and enabling the detection of minute variation of tank pressure.

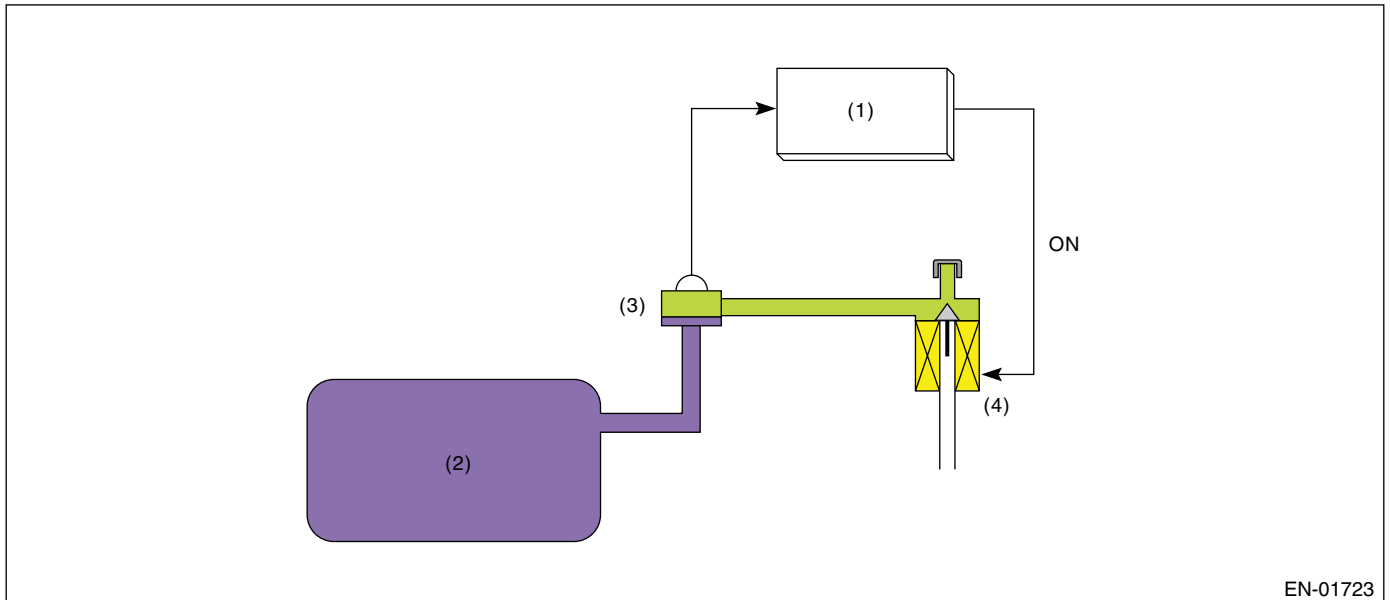

EN-01723

- | | |
|---------------------------------|---|
| (1) Engine control module (ECM) | (4) Atmospheric pressure switching solenoid |
| (2) Fuel tank | |
| (3) Fuel tank pressure sensor | |

NOTE:

ECM also has the atmospheric air pressure sensor, and always monitors atmospheric air. However, as the monitoring range is large, that is, 53 to 107 kPa (400 to 800 mmHg, 16 to 32 inHg) it is not suitable for detection of minute pressure variation.

In the case of small leakage diagnosis, the tank pressure variation is very small, that is, 0.13 to 0.27 kPa (1 to 2 mmHg, 0.04 to 0.08 inHg) and the fuel tank pressure sensor is equipped.

DIAGNOSTIC TROUBLE CODE (DTC) DETECTING CRITERIA

GENERAL DESCRIPTION

3. ENABLE CONDITION

0.04-inch Diagnosis

Secondary Parameters	Enable Conditions
Battery voltage	≥ 10.9 V
Barometric pressure	≥ 75.1 kPa (563 mmHg, 22.2 inHg)
Total time of canister purge operation	120 seconds or more
After starting engine	856 seconds or more
Learning value of evaporation gas density	≤ 0.04
Engine speed	1050 \leftrightarrow 6500 rpm
Fuel tank pressure	-1.3 — 0.91 kPa (-10 — 6.8 mmHg, -0.39 — 0.27 inHg)
Intake manifold vacuum (relative pressure)	< -13.3 kPa (-100 mmHg, -3.92 inHg)
Vehicle speed	≥ 32 km/h (20 MPH)
Fuel level	9.6 \leftrightarrow 48 ℓ (2.54 \leftrightarrow 12.7 US gal, 2.11 \leftrightarrow 10.6 Imp gal)
Closed air/fuel ratio control	In operation
Fuel temperature	-10 \leftrightarrow 45°C (14 \leftrightarrow 113°F)
Intake air temperature	≥ -10 °C (14°F)
Pressure change per second	< 0.13 kPa (0.95 mmHg, 0.037 inHg)
Min. pressure change per second – Max. pressure change per second	< 0.23 kPa (1.75 mmHg, 0.07 inHg)
Fuel level change	< 3.0 ℓ (3.2 US gal, 2.6 Imp gal)/128 milliseconds
Air fuel ratio	0.76 — 1.25

DIAGNOSTIC TROUBLE CODE (DTC) DETECTING CRITERIA

GENERAL DESCRIPTION

0.02-inch Diagnosis

Secondary Parameters	Enable Conditions
(At starting a diagnosis)	
Battery voltage	≥ 10.9 V
Atmospheric pressure	≥ 75.1 kPa (563 mmHg, 22.2 inHg)
Since last incomplete diagnosis event of 0.02-inch leakage	> 120 seconds
Total time of canister purge operation	120 second or more
After starting engine	335 second or more
Fuel temperature	-10 ↔ 35°C (14 ↔ 95°F)
Or engine coolant temperature at engine start	< 45°C (113°F)
And time after engine start	< 2400 seconds
Fuel level	9.6 ↔ 48 ℓ (2.54 ↔ 12.7 US gal, 2.11 ↔ 10.6 Imp gal)
Ambient temperature	≥ -10°C (14°F)
(Ambient – fuel) temperature	< 1°C (1.8°F)
Fuel tank pressure below -3.01 kPa (-22.8 mmHg, -0.88 inHg) (during same driving cycle)	Up to 2 times
Intake manifold vacuum (relative pressure)	< -13.3 kPa (-100 mmHg, -3.92 inHg)
Fuel tank pressure	-0.7 — 0.9 kPa (-5 — 7 mmHg, -0.20 — 0.28 inHg)
Vehicle speed	≥ 68 km/h (42 MPH)
Closed air/fuel ratio control	In operation
Engine speed	1500 ↔ 3000 rpm
(During diagnosis)	
P1	-0.13 ↔ 0.13 kPa (-1 ↔ 1 mmHg, -0.04 ↔ 0.04 inHg)
Pressure change per second	< 0.13 kPa (0.95 mmHg, 0.037 inHg)
Fuel level change	2 ↔ 3 ℓ (2.1 ↔ 3.2 US gal, 1.8 ↔ 2.6 Imp gal)
Tank pressure	< 1.03 kPa (7.72 mmHg, 0.037 inHg)
Min. tank pressure change per second – Max. tank pressure change per second	< 0.23 kPa (1.75 mmHg, 0.07 inHg)
Change of atmospheric pressure during P1 calculation	-0.04 ↔ 0.17 kPa (-0.3 ↔ 1.3 mmHg, -0.01 ↔ 0.05 inHg)
Change of atmospheric pressure during P2 calculation	-0.09 ↔ 0.17 kPa (-0.7 ↔ 1.3 mmHg, -0.028 ↔ 0.051 inHg)

DIAGNOSTIC TROUBLE CODE (DTC) DETECTING CRITERIA

GENERAL DESCRIPTION

4. GENERAL DRIVING CYCLE

• 0.04-inch Diagnosis

- Perform the diagnosis only once in more than 856 seconds after the engine start at the constant driving speed of 32 km/h (20 MPH) or more.
- Pay attention to the fuel temperature and fuel level.

• 0.02-inch Diagnosis

- Perform diagnosis in more than 335 seconds after engine start at the constant speed of 68 km/h (42 MPH) or more, and then terminate the diagnosis when judged OK or NG.
- If not judged OK or NG, repeat the diagnosis until judged OK or NG.
- Pay attention to the fuel temperature and fuel level.

5. DIAGNOSTIC METHOD

- **MODE Z (Purge control solenoid valve open malfunction diagnosis, CPC close malfunction diagnosis)**

DTC P0457

DTC P1443

- **Purpose of Mode Z**

When performing the leakage diagnosis of EVAP system, CCV and CPC have to operate normally. Therefore, mode Z is used to diagnose the CCV close fixation and CPC open fixation.

If the CCV closed fixation trouble or CPC open fixation trouble is detected, the EVAP system leakage diagnosis is cancelled.

If the CCV closed fixation trouble occurred, negative pressure is generated from the engine to pressure control solenoid valve when pressure control solenoid valve is closed and CPC is opened. When this status occurs the valve cannot be opened for the pressure control solenoid valve structure if the negative pressure is larger than electromagnetic force when pressure control solenoid valve solenoid is set to ON in order to open the valve.

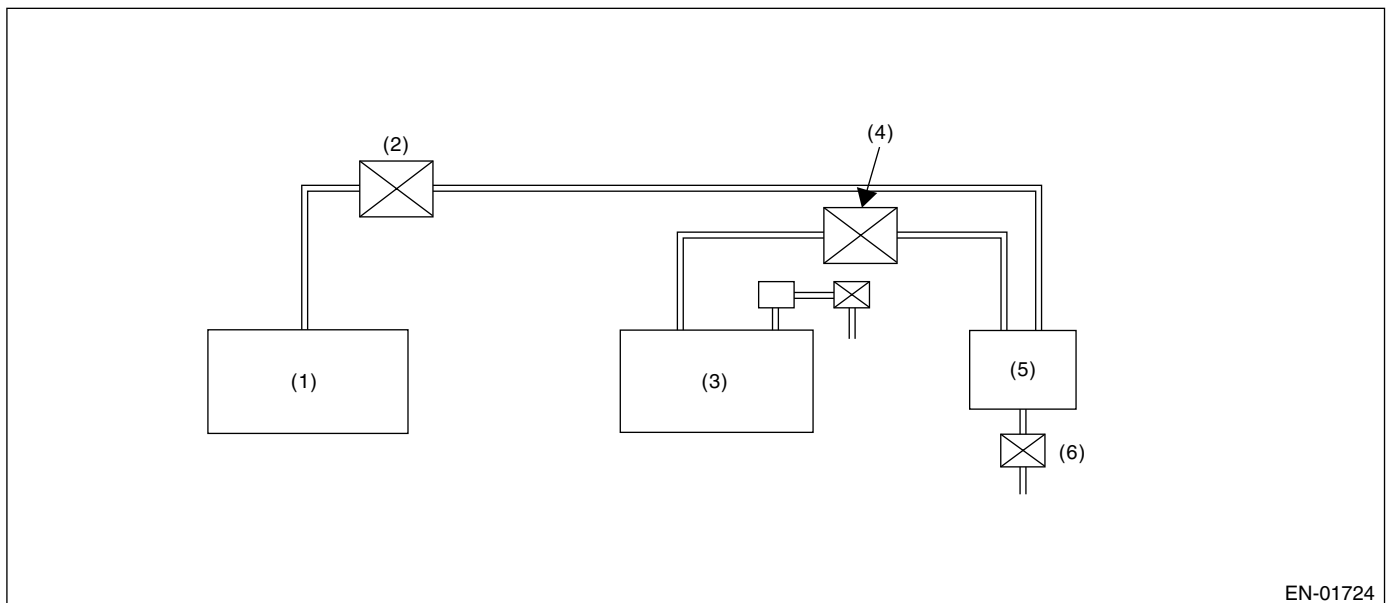

EN-01724

- | | | |
|---------------------------------------|---|---------------------|
| (1) Engine | (4) Pressure control solenoid valve close | (6) CCV stuck close |
| (2) Purge control solenoid valve open | | |
| (3) Fuel tank | (5) Canister | |

DIAGNOSTIC TROUBLE CODE (DTC) DETECTING CRITERIA

GENERAL DESCRIPTION

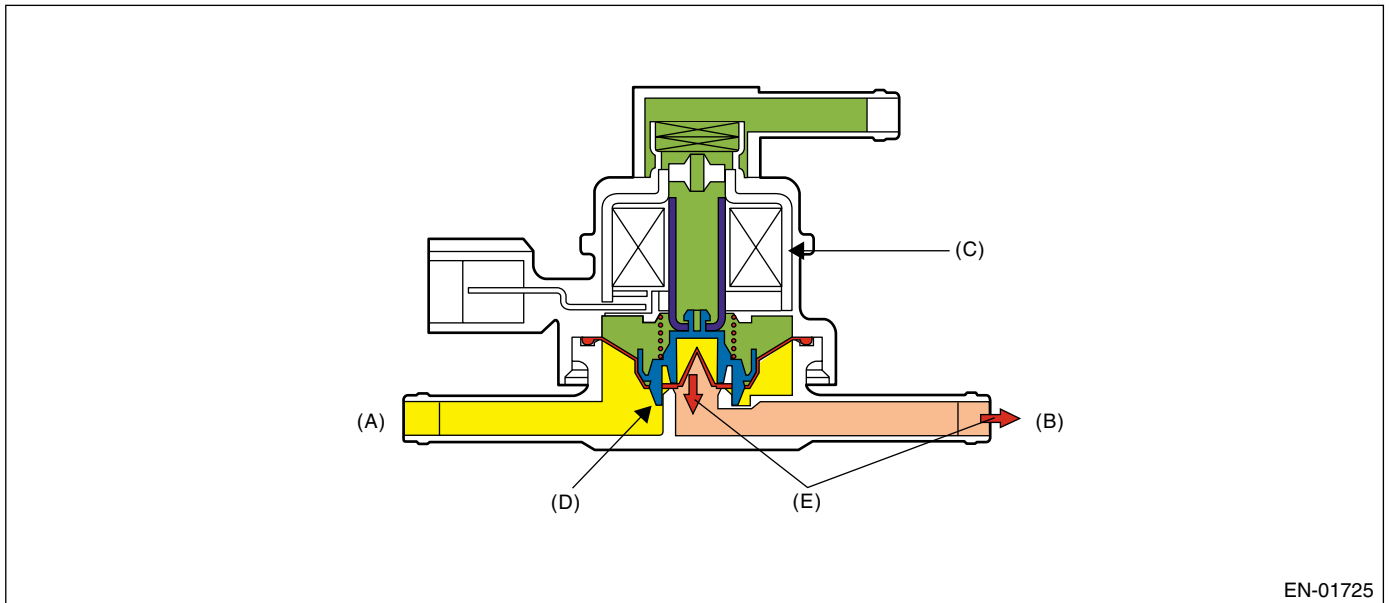

EN-01725

- | | | |
|-------------------------------------|---------------------------|-----------------------|
| (A) To fuel tank | (C) Solenoid ON | (E) Negative pressure |
| (B) To canister (Negative pressure) | (D) Valve cannot be open. | |

• Diagnostic method

CCV closed fixation diagnosis and CPC open fixation diagnosis are performed in mode Z as shown in the figure below.

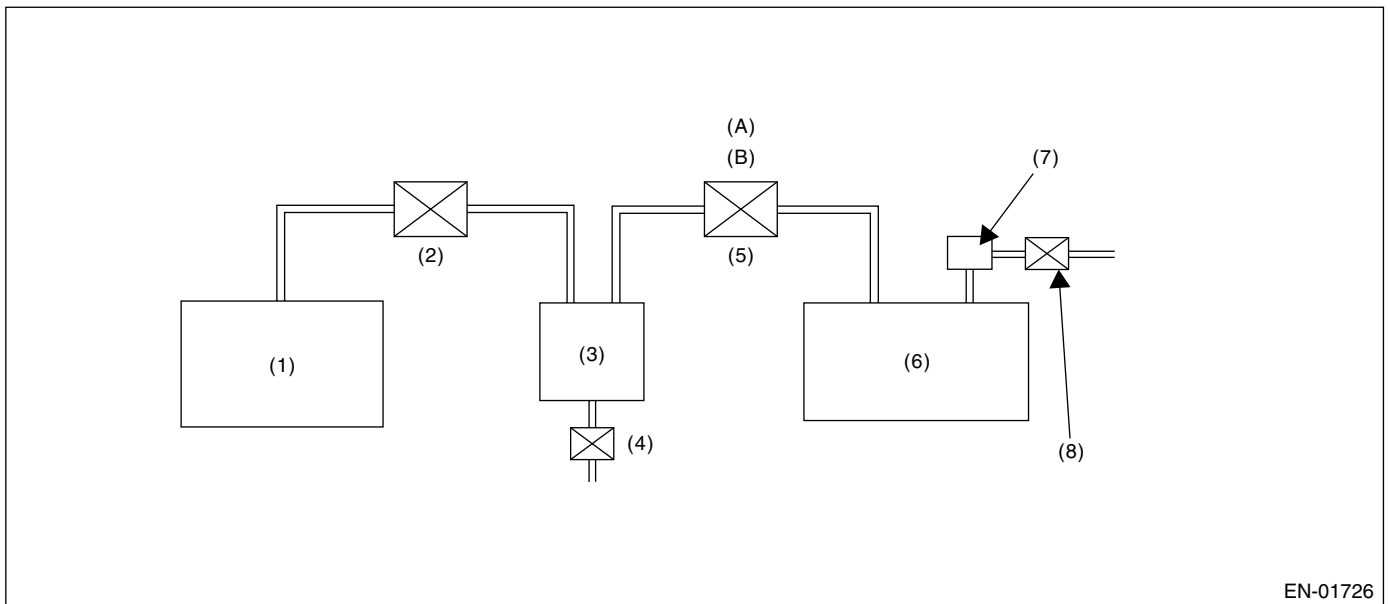

EN-01726

- | | | |
|-------------------------------------|--|---|
| (1) Engine | (6) Fuel tank | (A) Normal condition: mechanical control |
| (2) Purge control solenoid valve | (7) Fuel tank pressure sensor | (B) Under the diagnosis: electronic control |
| (3) Canister | (8) Tank pressure switching solenoid valve | |
| (4) Drain valve | | |
| (5) Pressure control solenoid valve | | |

DIAGNOSTIC TROUBLE CODE (DTC) DETECTING CRITERIA

GENERAL DESCRIPTION

• Normal Operation

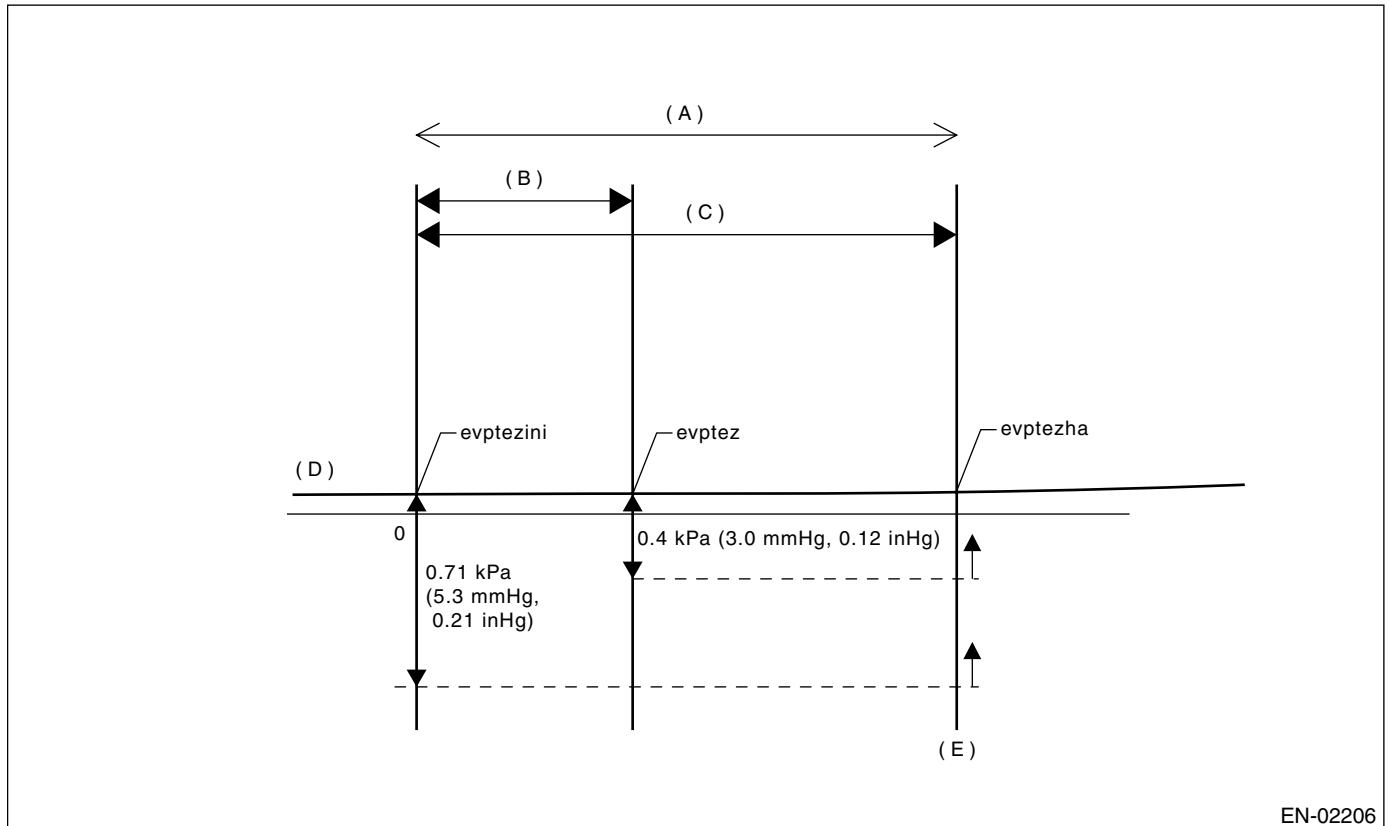

EN-02206

(A) Mode Z

(C) 3 seconds

(E) OK judgement

(B) 1 second

(D) Fuel tank pressure

- $evptez - evptezha \leq 0.4 \text{ kPa (3.0 mmHg, 0.12 inHg)}$
 - $evptezini - evptezha \leq 0.71 \text{ kPa (5.3 mmHg, 0.21 inHg)}$
- Judge normal when these calculations are completed.

DIAGNOSTIC TROUBLE CODE (DTC) DETECTING CRITERIA

GENERAL DESCRIPTION

• Drain Valve close fixation

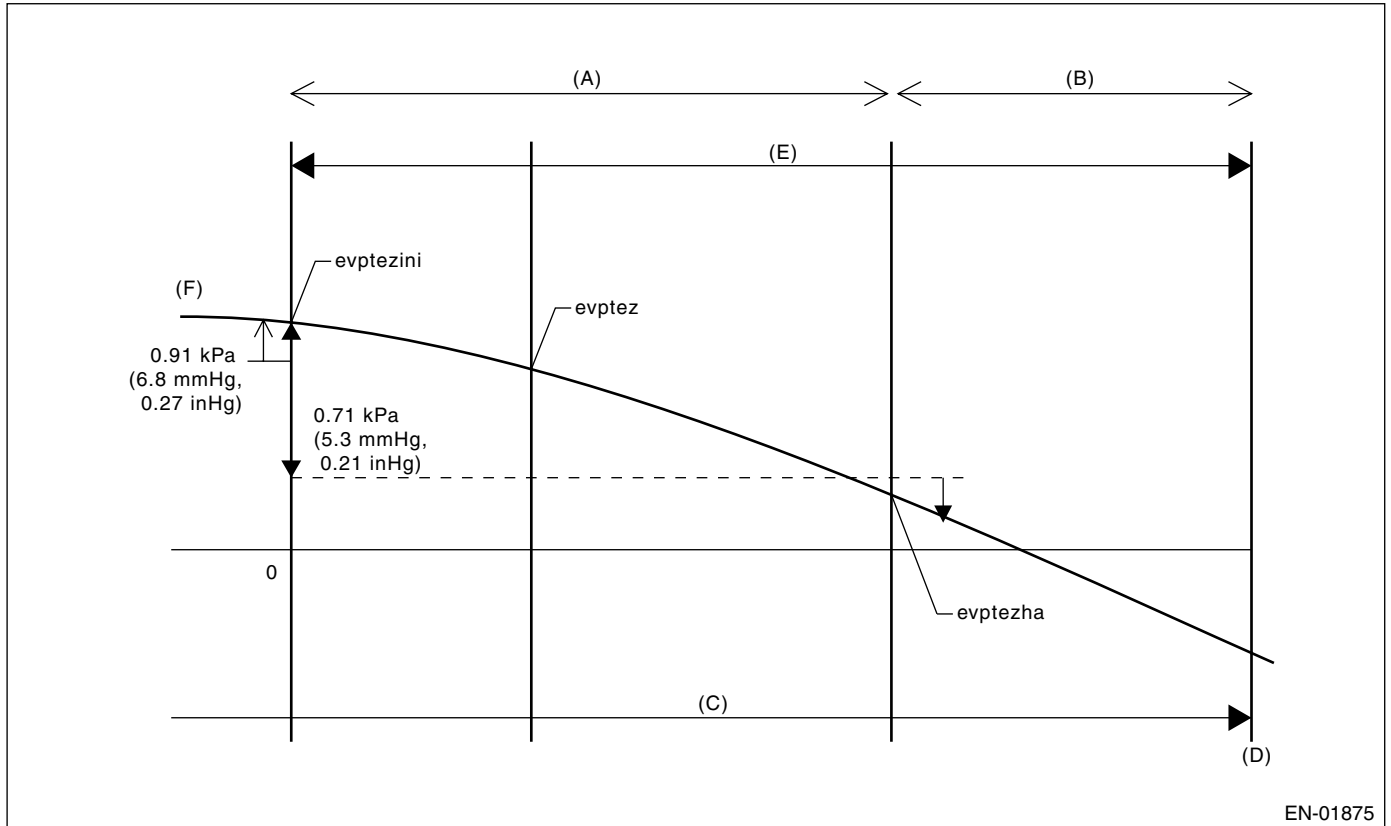

- | | |
|--|------------------------|
| (A) Mode Z | (D) Judgement |
| (B) Mode Z extened | (E) 16S |
| (C) Fuel does not waver more than 3 seconds. | (F) Fuel tank pressure |

- $evptezini - evptezha > 0.71 \text{ kPa (5.3 mmHg, 0.21 inHg)}$
 - $evptezini > 0.91 \text{ kPa (6.8 mmHg, 0.27 inHg)}$
- Judge normal when these calculations are completed.

• Diagnosing Function of CCV [P1443]

CCV functional diagnosis is performed by monitoring the tank pressure variation in Mode Z.

Normality Judgment

Judge OK and change to Mode A when the criteria below are completed in 3 seconds after Mode Z started.

• Judgment Value

Malfunction Criteria	Threshold Value	DTC
(Tank pressure in 3 seconds after Mode Z started) – (Tank pressure when Mode Z finished)	$\leq 0.4 \text{ kPa (3.0 mmHg, 0.12 inHg)}$	P1443
(Tank pressure when Mode Z started) – (Tank pressure when Mode Z finished)	$\leq 0.7 \text{ kPa (5.3 mmHg, 0.21 inHg)}$	P0457

DIAGNOSTIC TROUBLE CODE (DTC) DETECTING CRITERIA

GENERAL DESCRIPTION

Abnormality Judgment

If OK judgment cannot be made, extend Mode Z 16 seconds more, and judge NG when all the criteria below are completed in 16 seconds.

• Judgment Value

Malfunction Criteria	Threshold Value	DTC
Tank pressure when Mode Z started	> 0.91 kPa (6.8 mmHg, 0.27 inHg)	P1443
(Tank pressure when Mode Z started) – (Tank pressure when Mode Z finished)	> 0.7 kPa (5.3 mmHg, 0.21 inHg)	

Time Needed for Diagnosis: 4 seconds

Malfunction Indicator Light Illumination: Illuminates as soon as malfunction occurs.

Finish the Evap. diagnosis when making NG judgment for drain valve close fixation.

Cancel the Evap. diagnosis when the OK/NG judgment for drain valve close fixation and purge control solenoid valve open fixation cannot be made in Mode Z.

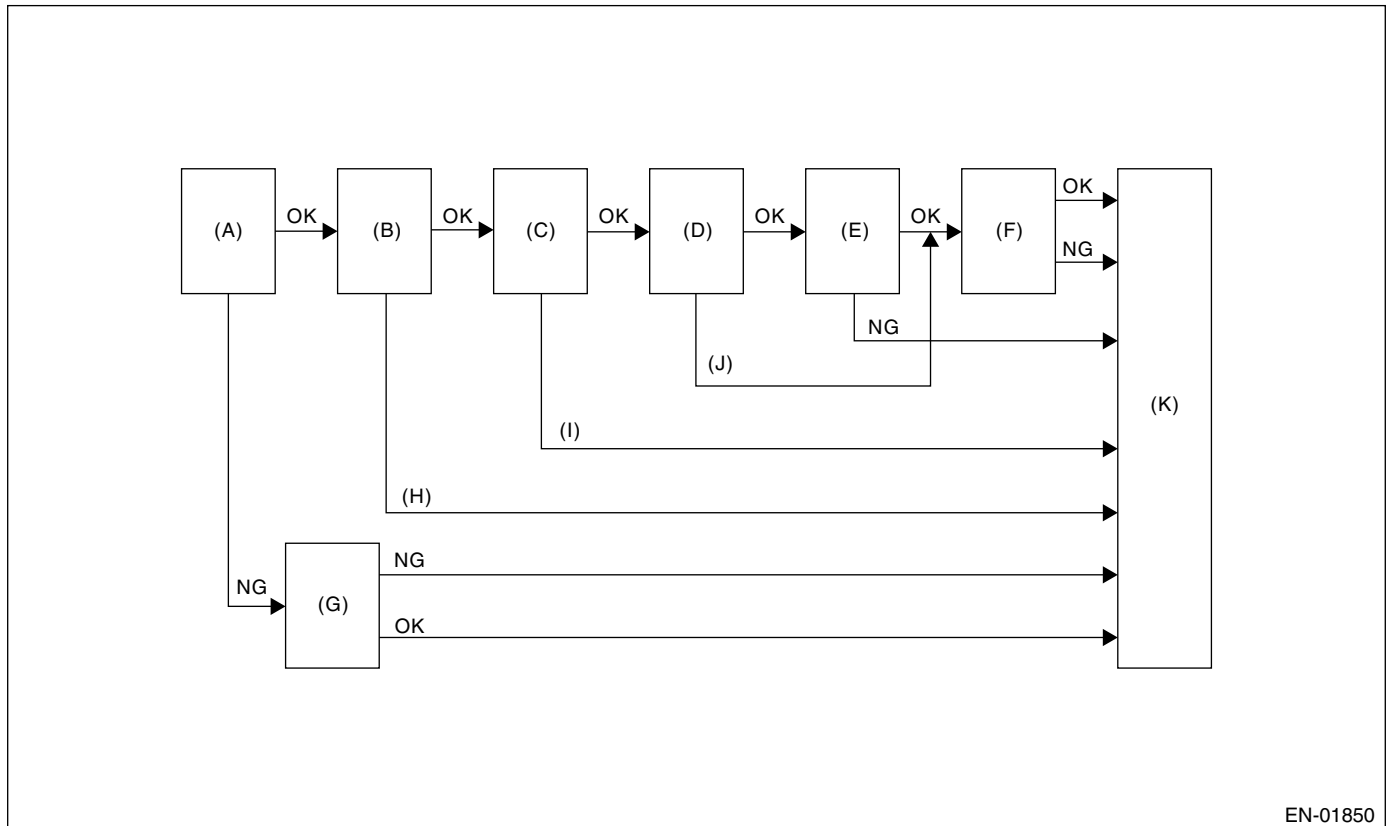

EN-01850

- | | | |
|------------|-------------------|-----------------------------|
| (A) Mode Z | (E) Mode D | (I) Large leakage diagnosis |
| (B) Mode A | (F) Mode E | (J) Quick OK judgement |
| (C) Mode B | (G) Mode Z Extend | (K) END |
| (D) Mode C | (H) Cancel | |

• Diagnosing function of CPC [P0457]

CPC functional diagnosis is performed by monitoring the tank pressure in Mode Z.

Normality Judgment

Make OK judgment in 3 seconds after Mode Z started, and change to Mode A if OK.

Both diagnostic method and judgment value are the same as PCV normality judgment.

DIAGNOSTIC TROUBLE CODE (DTC) DETECTING CRITERIA

GENERAL DESCRIPTION

• Leak Diagnosis

DTC P0442

DTC P0456

DTC P0457

• Diagnostic method

• The diagnostic method consists of creating a sealed vacuum in the fuel tank and then determining the presence of leakage from the speed at which the tank internal pressure returns to atmospheric pressure.

• The diagnosis is divided into the following five phases.

Mode A: (Estimation of evaporation gas yield)

The tank pressure variation amount in Mode A is calculated as P1. The tank pressure variation amount in Mode A is calculated as P1. After calculating P1, change to Mode B.

Mode B: (Seal negative pressure)

Introduce the negative pressure in the intake manifold to the tank.

Approx. 0 → -1.4 kPa (0 → -10.5 mmHg, 0 → -0.41 inHg) (0.04-in diagnosis)

Approx. 0 → -3.05 kPa (0 → -22.9 mmHg, 0 → -0.9 inHg) (0.02-in diagnosis)

When the pressure above (desired negative pressure) is reached, Mode C is entered.

In this case, if the tank pressure does not become the desired negative pressure, judge that there is a large leakage in the system.

Judge NG when the malfunction criteria below is completed.

Finish the Evap. diagnosis when judging large leak (10 seconds) in 0.04-inch diagnosis. Cancel the diagnosis (10 to 20 seconds) in 0.02-inch diagnosis.

Abnormality Judgment

Judge NG (large leak) when the criteria below are completed in the specified time.

• Judgment Value

Malfunction Criteria	Threshold Value	DTC
(0.04-inch diagnosis) Time for Mode B (Tank pressure during Mode B) – (Tank pressure when Mode B started)	10 seconds < -0.5 kPa (-4 mmHg, -0.16 inHg)	P0457

Mode C: (Check increasing pressure)

Stop the introduction of negative pressure. (Wait until the tank pressure returns to the start level of P2 calculation.)

Change to Mode D when the tank pressure returns to the start level of P2 calculation.

Judge immediate OK and change to Mode E when it does not return in spite of spending the specified time.

	Tank pressure when P2 calculation started	Time for immediate OK judgment
0.04-inch diagnosis	-1.3 kPa (-9.75 mmHg, -0.38 inHg)	15 seconds
0.02-inch diagnosis	-3 kPa (-22.5 mmHg, -0.89 inHg)	20 seconds

Mode D: (Measurement of negative pressure changes)

Monitor the pressure variation in the tank in Mode D. In this case, the tank pressure increases, that is, the pressure becomes as high as the atmospheric air pressure, because evaporator is generated. However, if any leakage exists, the pressure increases additionally in proportion to this leakage. The pressure variation of this tank is P2.

After calculating P2, perform small leak diagnosis and change to Mode E if normal. Complete Evap. diagnosis if abnormal.

• After Mode D

Assigning P1 and P2, which are tank variations measured in Mode A and Mode B, to the formula below, judge the small leakage of the system. If the measured judgment value exceeds the threshold value, it is judged to be malfunction.

DIAGNOSTIC TROUBLE CODE (DTC) DETECTING CRITERIA

GENERAL DESCRIPTION

• 0.04-inch Diagnosis

Abnormality Judgment

Judge NG when the criteria below are completed and judge OK when not completed.

• Judgment Value

Malfunction Criteria	Threshold Value	DTC
P2 – 1.5 × P1 P2: Change of tank pressure within 16 seconds on Mode D P1: Change of tank pressure within 16 seconds on Mode A	> Value on map 7. *Threshold value: Figure (Fuel level vs Tank temperature)	P0442

*1.5: Compensation value of the amount of evaporator occurrence. (Because evaporator increases more when becoming negative pressure.)

• Map 7 Limit of malfunction criteria for 0.04-inch leak as Evap. diagnosis.

Fuel temperature & Fuel level	5°C (41°F)	15°C (59°F)	25°C (77°F)	35°C (95°F)	45°C (113°F)
10 L (2.6 US gal, 2.2 Imp gal)	0.31 kPa (2.34 mmHg, 0.092 inHg)	0.31 kPa (2.34 mmHg, 0.092 inHg)	0.33 kPa (2.49 mmHg, 0.098 inHg)	0.35 kPa (2.64 mmHg, 0.104 inHg)	0.37 kPa (2.80 mmHg, 0.110 inHg)
20 L (5.3 US gal, 4.4 Imp gal)	0.35 kPa (2.64 mmHg, 0.104 inHg)	0.35 kPa (2.65 mmHg, 0.104 inHg)	0.38 kPa (2.84 mmHg, 0.112 inHg)	0.41 kPa (3.08 mmHg, 0.121 inHg)	0.44 kPa (3.28 mmHg, 0.129 inHg)
30 L (7.9 US gal, 6.6 Imp gal)	0.39 kPa (2.94 mmHg, 0.116 inHg)	0.39 kPa (2.94 mmHg, 0.116 inHg)	0.42 kPa (3.18 mmHg, 0.125 inHg)	0.47 kPa (3.52 mmHg, 0.139 inHg)	0.50 kPa (3.76 mmHg, 0.148 inHg)
40 L (10.6 US gal, 8.8 Imp gal)	0.45 kPa (3.35 mmHg, 0.132 inHg)	0.45 kPa (3.35 mmHg, 0.132 inHg)	0.47 kPa (3.49 mmHg, 0.137 inHg)	0.50 kPa (3.74 mmHg, 0.147 inHg)	0.52 kPa (3.88 mmHg, 0.153 inHg)
50 L (13.2 US gal, 11.0 Imp gal)	0.50 kPa (3.76 mmHg, 0.148 inHg)	0.50 kPa (3.76 mmHg, 0.148 inHg)	0.51 kPa (3.80 mmHg, 0.150 inHg)	0.53 kPa (3.95 mmHg, 0.156 inHg)	0.53 kPa (3.99 mmHg, 0.157 inHg)

• 0.02-inch Diagnosis

Abnormality Judgment

Judge NG when the criteria below are completed.

DIAGNOSTIC TROUBLE CODE (DTC) DETECTING CRITERIA

GENERAL DESCRIPTION

• Judgment Value

Malfunction Criteria	Threshold Value	DTC
P2 – 1.5 × P1 P2: Change of tank pressure within 22 seconds on Mode D P1: Change of tank pressure within 22 seconds on Mode A	> Value on map 8. *Threshold value: Figure (Fuel level vs Tank temperature)	P0456

• Map 8 Limit of malfunction criteria for 0.04-inch leak as Evap. diagnosis.

Fuel temperature & Fuel level	15°C (59°F)	25°C (77°F)	35°C (95°F)	40°C (104°F)
10 L (2.6 US gal, 2.2 Imp gal)	0.34 kPa (2.57 mmHg, 0.101 inHg)	0.37 kPa (2.80 mmHg, 0.110 inHg)	0.44 kPa (3.30 mmHg, 0.130 inHg)	0.73 kPa (5.49 mmHg, 0.216 inHg)
20 L (5.3 US gal, 4.4 Imp gal)	0.38 kPa (2.83 mmHg, 0.111 inHg)	0.42 kPa (3.12 mmHg, 0.123 inHg)	0.49 kPa (3.70 mmHg, 0.146 inHg)	0.79 kPa (5.92 mmHg, 0.233 inHg)
30 L (7.9 US gal, 6.6 Imp gal)	0.41 kPa (3.09 mmHg, 0.122 inHg)	0.46 kPa (3.43 mmHg, 0.135 inHg)	0.55 kPa (4.10 mmHg, 0.161 inHg)	0.85 kPa (6.34 mmHg, 0.250 inHg)
40 L (10.6 US gal, 8.8 Imp gal)	0.46 kPa (3.46 mmHg, 0.136 inHg)	0.49 kPa (3.66 mmHg, 0.144 inHg)	0.56 kPa (4.18 mmHg, 0.165 inHg)	0.89 kPa (6.70 mmHg, 0.264 inHg)
50 L (13.2 US gal, 11.0 Imp gal)	0.51 kPa (3.83 mmHg, 0.151 inHg)	0.52 kPa (3.89 mmHg, 0.153 inHg)	0.57 kPa (4.25 mmHg, 0.167 inHg)	0.93 kPa (7.00 mmHg, 0.276 inHg)

Normality Judgment

Judge OK when the criteria below are completed.

DIAGNOSTIC TROUBLE CODE (DTC) DETECTING CRITERIA

GENERAL DESCRIPTION

• Judgment Value

Malfunction Criteria	Threshold Value	DTC
P2 – 1.5 × P1	> Valve on map 9.	P0456

• Map 9.

Fuel temperature & Fuel level	15°C (59°F)	25°C (77°F)	35°C (95°F)	40°C (104°F)
10 L (2.6 US gal, 2.2 Imp gal)	0.21 kPa (1.59 mmHg, 0.063 inHg)	0.21 kPa (1.59 mmHg, 0.063 inHg)	0.26 kPa (1.97 mmHg, 0.078 inHg)	0.31 kPa (2.36 mmHg, 0.093 inHg)
20 L (5.3 US gal, 4.4 Imp gal)	0.28 kPa (2.09 mmHg, 0.082 inHg)	0.28 kPa (2.09 mmHg, 0.082 inHg)	0.33 kPa (2.45 mmHg, 0.096 inHg)	0.37 kPa (2.81 mmHg, 0.111 inHg)
30 L (7.9 US gal, 6.6 Imp gal)	0.35 kPa (2.59 mmHg, 0.102 inHg)	0.35 kPa (2.59 mmHg, 0.102 inHg)	0.39 kPa (2.92 mmHg, 0.115 inHg)	0.43 kPa (3.26 mmHg, 0.128 inHg)
40 L (10.6 US gal, 8.8 Imp gal)	0.30 kPa (2.26 mmHg, 0.089 inHg)	0.30 kPa (2.26 mmHg, 0.089 inHg)	0.35 kPa (2.64 mmHg, 0.104 inHg)	0.40 kPa (3.02 mmHg, 0.119 inHg)
50 L (13.2 US gal, 11.0 Imp gal)	0.26 kPa (1.93 mmHg, 0.076 inHg)	0.26 kPa (1.93 mmHg, 0.076 inHg)	0.31 kPa (2.36 mmHg, 0.093 inHg)	0.37 kPa (2.78 mmHg, 0.109 inHg)

If not judged OK or NG, repeat the diagnosis until judged OK or NG.

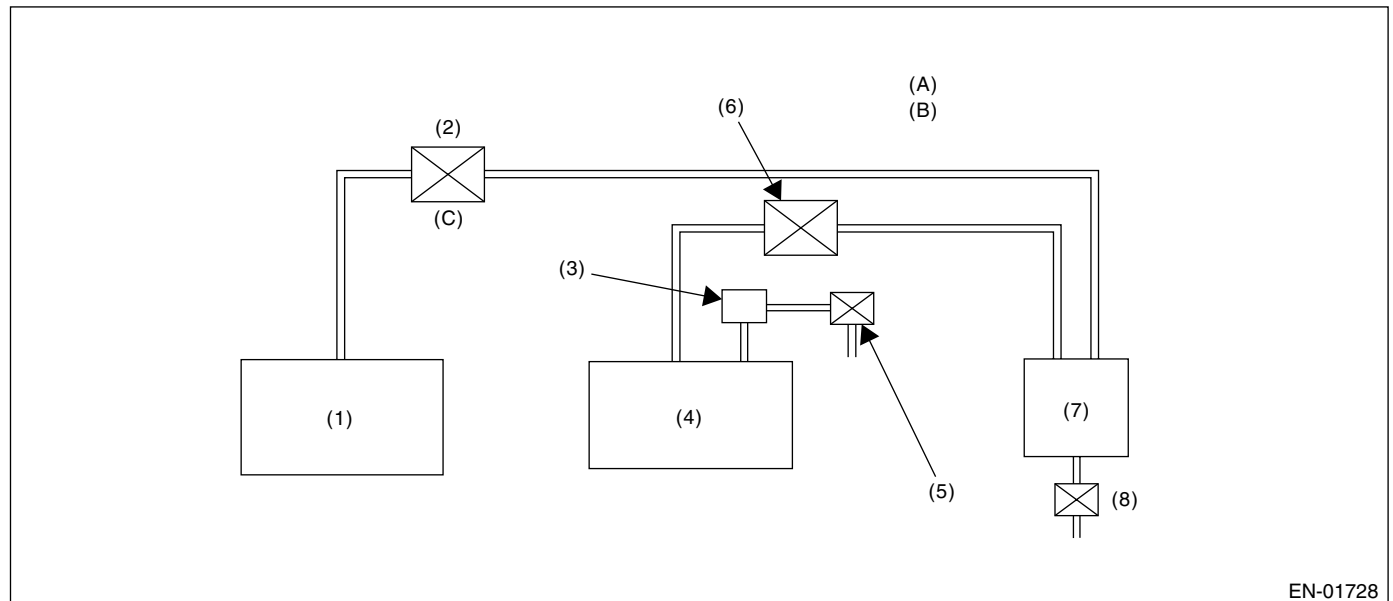

EN-01728

- | | | |
|---|-------------------------------------|--|
| (1) Engine | (6) Pressure control solenoid valve | (A) Normal condition: mehcanical control |
| (2) Purge control solenoid valve | (7) Canister | (B) Under the diagnosis electronic control |
| (3) Fuel tank pressure sensor | (8) Drain valve | (C) Duty control |
| (4) Fuel tank | | |
| (5) Atmospheric pressure switching solenoid | | |

DIAGNOSTIC TROUBLE CODE (DTC) DETECTING CRITERIA

GENERAL DESCRIPTION

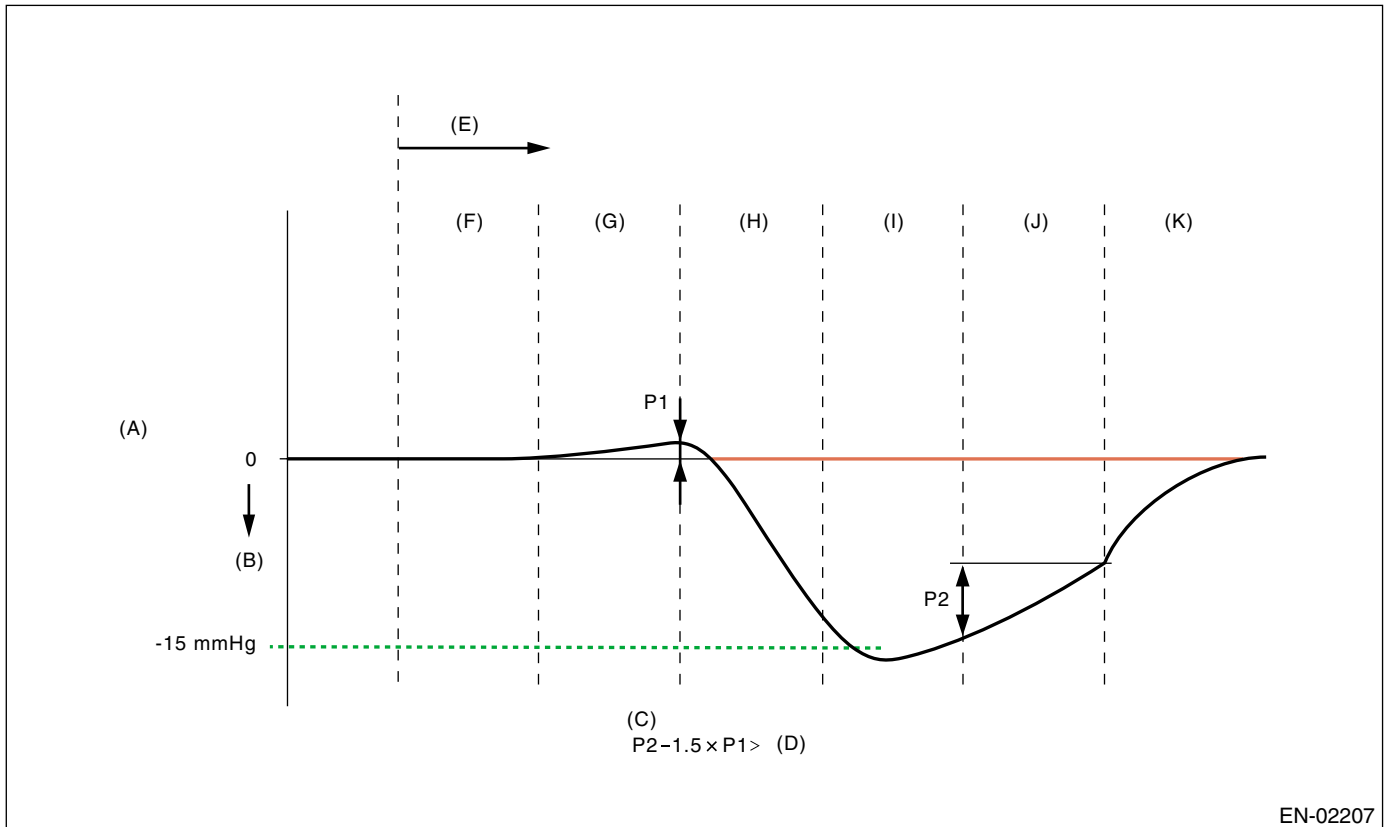

EN-02207

- | | | |
|------------------------|---------------------|------------|
| (A) Fuel tank pressure | (E) Diagnosis start | (I) Mode C |
| (B) Negative pressure | (F) Mode Z | (J) Mode D |
| (C) Small leakage | (G) Mode A | (K) Mode E |
| (D) Threshold value | (H) Mode B | |

• CCV Property Diagnosis [P1443]

Mode E:

The tank pressure must become again as high as the atmospheric air pressure, after the evaporation diagnosis (normal judgment on Mode C or after Mode D). If the tank pressure does not become as high as the atmospheric air pressure, judge that CCV is blocked.

Judge NG when the criteria below are completed.

Malfunction Criteria	Threshold Value	DTC
Fuel tank pressure difference from the end of EVAP sys. diagnosis to 4 seconds later	< 0.36 kPa (2.72 mmHg, 0.11 inHg)	P1443

• Time Needed for Diagnosis:

- | | |
|------------|------------------|
| 0.04-inch: | 30 — 100 seconds |
| 0.02-inch: | 30 — 100 seconds |

Malfunction Indicator Light Illumination: Illuminates when malfunction occurs in 2 continuous drive cycles.

6. DTC CLEAR CONDITION

- When the OK idling cycle was completed 40 times in a row
- When "Clear Memory" was performed

DIAGNOSTIC TROUBLE CODE (DTC) DETECTING CRITERIA

GENERAL DESCRIPTION

7. MALFUNCTION INDICATOR LIGHT CLEAR CONDITION

- When the OK driving cycle was completed 3 times in a row
- When "Clear Memory" was performed

8. FAIL SAFE

Atmospheric purge solenoid function malfunction; Open the pressure control solenoid valve.

9. ECM OPERATION AT DTC SETTING

- Memorize the freeze frame data. (For test mode \$02)
- Memorize the diagnostic value and trouble standard value. (For test mode \$06)

DIAGNOSTIC TROUBLE CODE (DTC) DETECTING CRITERIA

GENERAL DESCRIPTION

BB:DTC P0447 — EVAPORATIVE EMISSION CONTROL SYSTEM VENT CONTROL CIRCUIT OPEN —

1. OUTLINE OF DIAGNOSIS

Detect the open or short circuit of drain valve.

Judge NG when the ECM output level is different from the actual terminal level.

2. COMPONENT DESCRIPTION

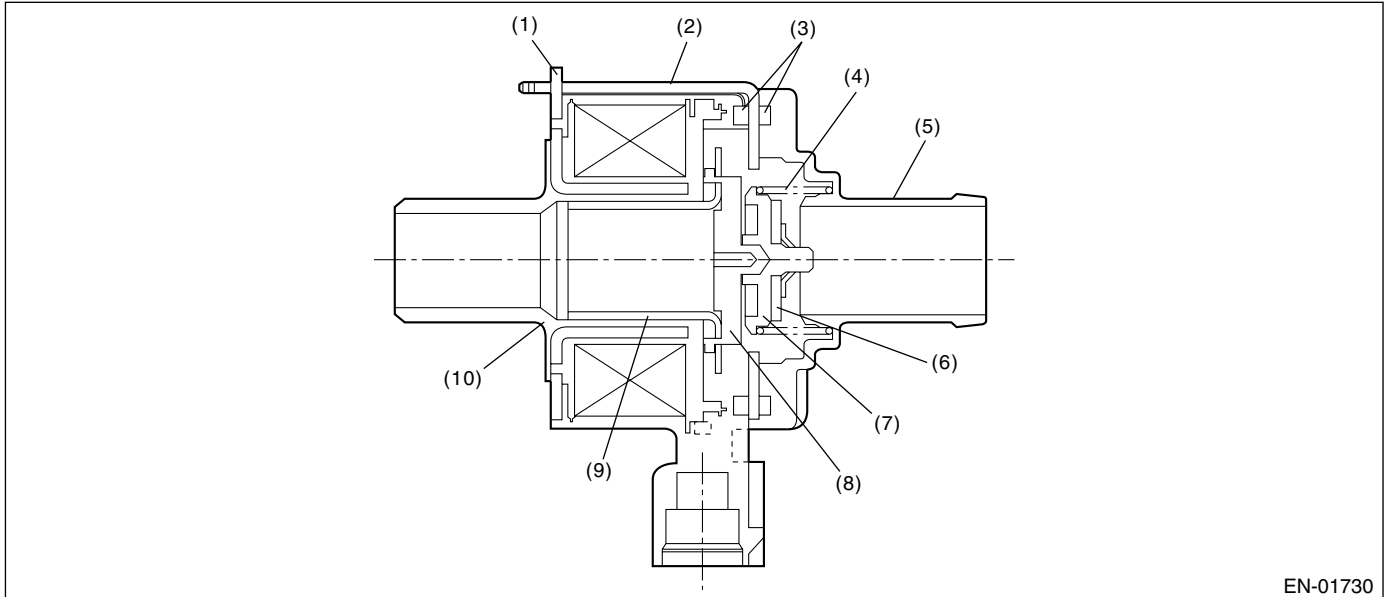

EN-01730

(1) Magnetic plate

(2) Yoke

(3) Packing

(4) Spring

(5) Valve seat

(6) Valve

(7) Plate

(8) Retainer

(9) Movable core

(10) Bobbin

3. ENABLE CONDITION

Secondary Parameters	Enable Conditions
None	

4. GENERAL DRIVING CYCLE

Always perform the diagnosis continuously.

DIAGNOSTIC TROUBLE CODE (DTC) DETECTING CRITERIA

GENERAL DESCRIPTION

5. DIAGNOSTIC METHOD

• Abnormality Judgment

Judge NG when the continuous time of completing the malfunction criteria below becomes more than 2.5 seconds.

• Judgment Value

Malfunction Criteria	Threshold Value
Ignition switch	ON
Battery voltage	≥ 10.9 V
After starting engine	1 second or more
Terminal output voltage when ECM sends OFF signal	Low

Time Needed for Diagnosis: 2.5 seconds

Malfunction Indicator Light Illumination: Illuminates as soon as the malfunction occurs.

• Normality Judgment

Judge OK and clear the NG when the malfunction criteria below are completed.

• Judgment Value

Malfunction Criteria	Threshold Value
Ignition switch	ON
Battery voltage	≥ 10.9 V
After starting engine	1 second or more
Terminal output voltage when ECM sends OFF signal	High

6. DTC CLEAR CONDITION

- When the OK idling cycle was completed 40 times in a row
- When "Clear Memory" was performed

7. MALFUNCTION INDICATOR LIGHT CLEAR CONDITION

- When the OK driving cycle was completed 3 times in a row
- When "Clear Memory" was performed

8. FAIL SAFE

PCV control: Open the PCV solenoid.

9. ECM OPERATION AT DTC SETTING

Memorize the freeze frame data. (For test mode \$02)

DIAGNOSTIC TROUBLE CODE (DTC) DETECTING CRITERIA

GENERAL DESCRIPTION

BC:DTC P0448 — EVAPORATIVE EMISSION CONTROL SYSTEM VENT CONTROL CIRCUIT SHORTED —

1. OUTLINE OF DIAGNOSIS

Detect the open or short circuit of drain valve.

Judge NG when the ECM output level is different from the actual terminal level.

2. COMPONENT DESCRIPTION

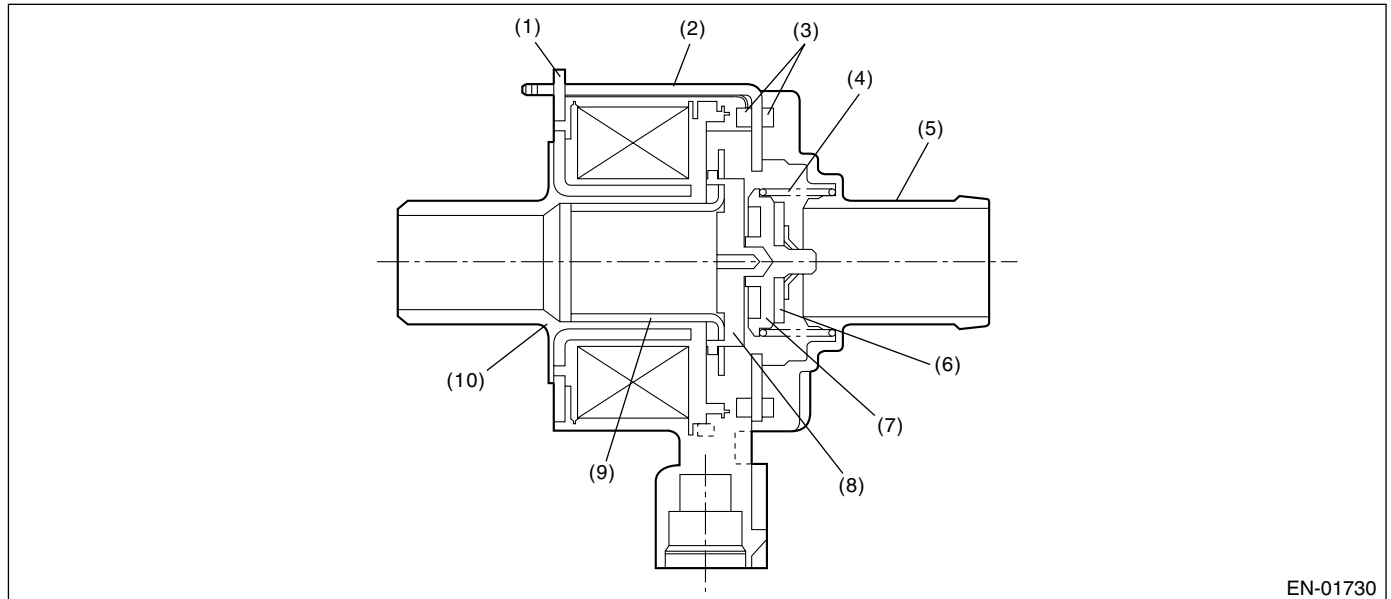

EN-01730

(1) Magnetic plate

(2) Yoke

(3) Packing

(4) Spring

(5) Valve seat

(6) Valve

(7) Plate

(8) Retainer

(9) Movable core

(10) Bobbin

3. ENABLE CONDITION

Secondary Parameters	Enable Conditions
None	

4. GENERAL DRIVING CYCLE

Always perform the diagnosis continuously.

DIAGNOSTIC TROUBLE CODE (DTC) DETECTING CRITERIA

GENERAL DESCRIPTION

5. DIAGNOSTIC METHOD

• Abnormality Judgment

Judge NG when the continuous time of completing the malfunction criteria below becomes more than 2.5 seconds.

• Judgment Value

Malfunction Criteria	Threshold Value
Ignition switch	ON
Battery voltage	≥ 10.9 V
After starting engine	1 second or more
Terminal output voltage when ECM sends ON signal	High

Time Needed for Diagnosis: 2.5 seconds

Malfunction Indicator Light Illumination: Illuminates as soon as the malfunction occurs.

• Normality Judgment

Judge OK and clear the NG when the malfunction criteria below are completed.

• Judgment Value

Malfunction Criteria	Threshold Value
Ignition switch	ON
Battery voltage	≥ 10.9 V
After starting engine	1 second or more
Terminal output voltage when ECM sends ON signal	Low

6. DTC CLEAR CONDITION

- When the OK idling cycle was completed 40 times in a row
- When "Clear Memory" was performed

7. MALFUNCTION INDICATOR LIGHT CLEAR CONDITION

- When the OK driving cycle was completed 3 times in a row
- When "Clear Memory" was performed

8. FAIL SAFE

PCV control: Open the PCV solenoid.

9. ECM OPERATION AT DTC SETTING

Memorize the freeze frame data. (For test mode \$02)

DIAGNOSTIC TROUBLE CODE (DTC) DETECTING CRITERIA

GENERAL DESCRIPTION

BD:DTC P0451 — EVAPORATIVE EMISSION CONTROL SYSTEM PRESSURE SENSOR RANGE/PERFORMANCE —

1. OUTLINE OF DIAGNOSIS

Detect the tank pressure sensor output property abnormality.

Judge NG when there is no pressure variation, which should exist in the tank, considering the engine status.

2. COMPONENT DESCRIPTION

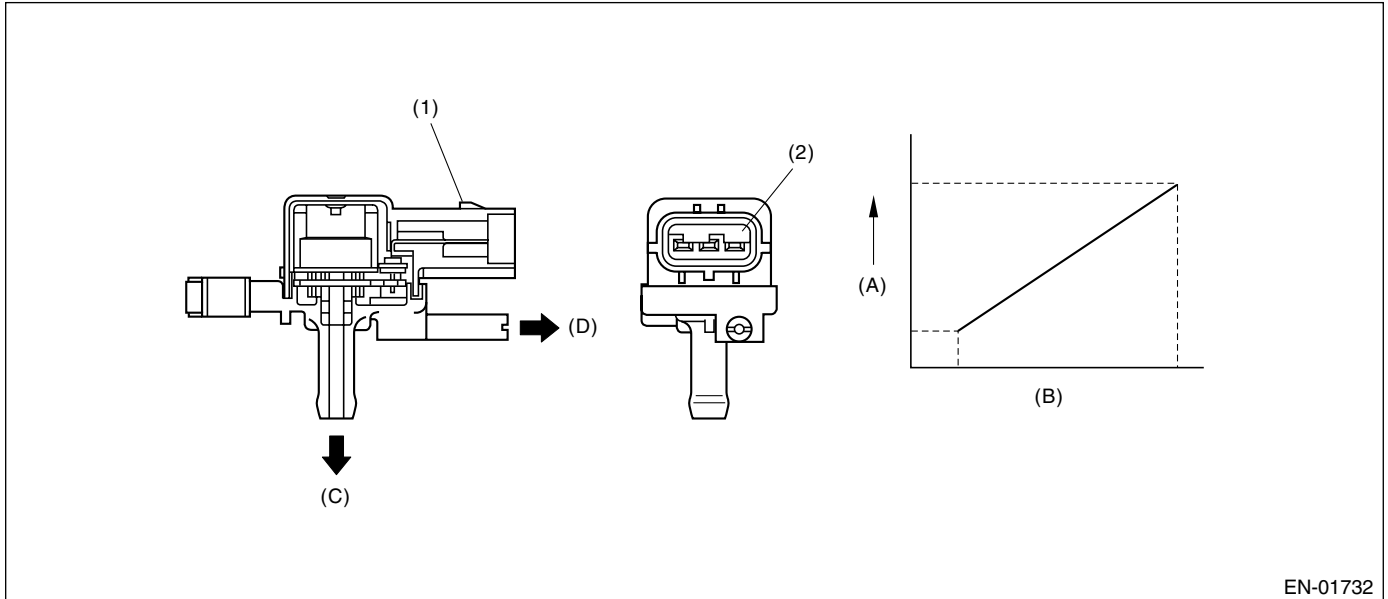

EN-01732

(1) Connector

(2) Terminal

(A) Output voltage

(B) Input voltage

(C) To fuel tank

(D) To atmospheric pressure switching solenoid

3. ENABLE CONDITION

Secondary Parameters	Enable Conditions
After starting engine	60 second or more
Fuel level	$\geq 18 \text{ l}$ (4.76 US gal, 3.96 Imp gal)
Fuel temperature	$< 35^{\circ}\text{C}$ (95°F)
Battery voltage	$\geq 10.9 \text{ V}$
Atmospheric pressure	$> 75.1 \text{ kPa}$ (563 mmHg, 22.2 inHg)
Engine speed	$< 6500 \text{ rpm}$
Purge control solenoid valve ON/OFF	Experienced

4. GENERAL DRIVING CYCLE

- Perform the diagnosis continuously in 60 seconds or more after starting the engine.
- Be sure to check the fuel level and fuel temperature.

DIAGNOSTIC TROUBLE CODE (DTC) DETECTING CRITERIA

GENERAL DESCRIPTION

5. DIAGNOSTIC METHOD

• Abnormality Judgment

Judge NG when the malfunction criteria below is completed.

• Judgment Value

Malfunction Criteria	Threshold Value
Number of times when the difference between the Max. fuel level and the Min. fuel level every 60 seconds is 5 ℓ (0.53 US gal, 0.44 Imp gal) or more (with enable condition completed)	≥ 16 times
Max. – Min. tank pressure (with enable condition completed)	< 0.05 kPa (0.375 mmHg, 0.02 inHg)
Max. – Min. fuel temperature (with enable condition completed)	≥ 7°C (44.6 °F)

If the fuel level (Max. – Min.) in every 60 seconds is less than 5 ℓ, extend 60 seconds more and make judgment with the Max. and Min. fuel level in 120 seconds.

If the difference did not appear though the time extended, extend the time (180, 240, 300 seconds) and continue the judgment.

Diagnosis counter will count up when the difference of fuel level (Max. – Min.) is more than 5 ℓ.

Time Needed for Diagnosis: 1 minute × 16 times or more

Malfunction Indicator Light Illumination: Illuminates when malfunction occurs in two continuous drive cycles.

• Normality Judgment

Judge OK when the malfunction criteria below is completed.

• Judgment Value

Malfunction Criteria	Threshold Value
Max. – Min. tank pressure	≥ 0.05 kPa (0.375 mmHg, 0.02 inHg)

6. DTC CLEAR CONDITION

- When the OK idling cycle was completed 40 times in a row
- When “Clear Memory” was performed

7. MALFUNCTION INDICATOR LIGHT CLEAR CONDITION

- When the OK driving cycle was completed 3 times in a row
- When “Clear Memory” was performed

8. FAIL SAFE

Purge control solenoid valve control: Purge fixation mode is prohibited.

9. ECM OPERATION AT DTC SETTING

Memorize the freeze frame data. (For test mode \$02)

DIAGNOSTIC TROUBLE CODE (DTC) DETECTING CRITERIA

GENERAL DESCRIPTION

BE:DTC P0452 — EVAPORATIVE EMISSION CONTROL SYSTEM PRESSURE SENSOR LOW INPUT —

1. OUTLINE OF DIAGNOSIS

Detect the open or short circuit of the fuel tank pressure sensor.
Judge NG when out of the standard value.

2. COMPONENT DESCRIPTION

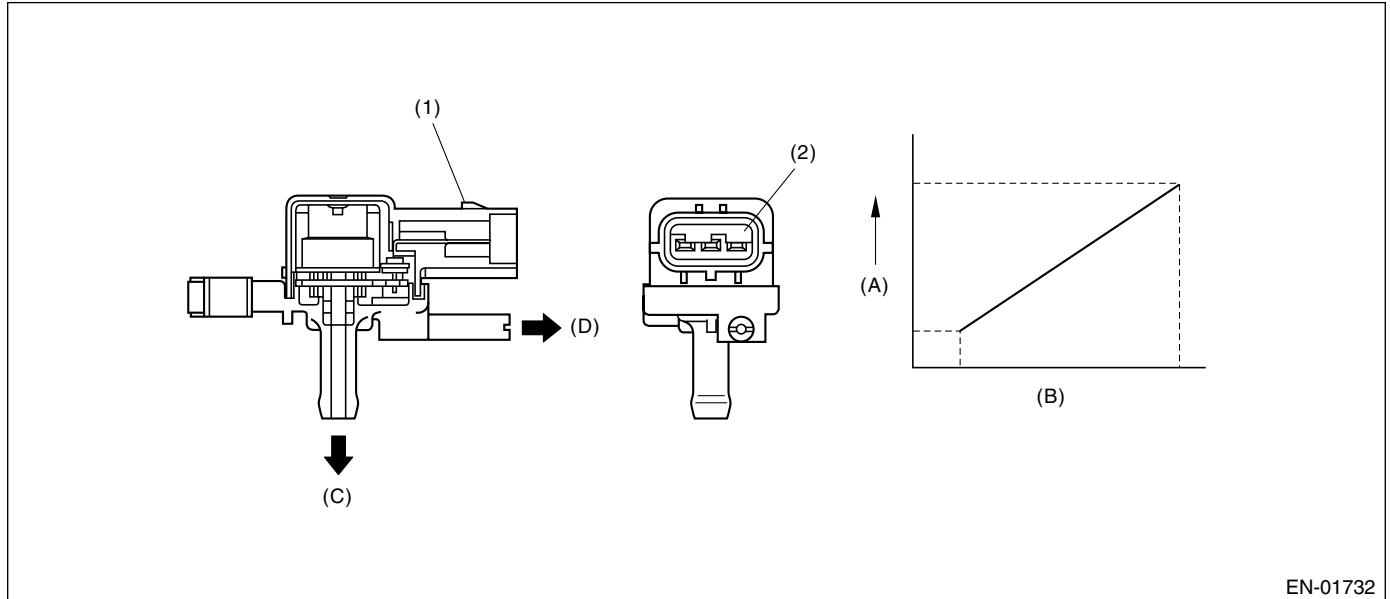

EN-01732

(1) Connector

(2) Terminal

(A) Output voltage

(B) Input voltage

(C) To fuel tank

(D) To atmospheric pressure switching solenoid

3. ENABLE CONDITION

Secondary Parameters	Enable Conditions
Battery voltage	≥ 10.9 V

4. GENERAL DRIVING CYCLE

Always perform the diagnosis continuously.

DIAGNOSTIC TROUBLE CODE (DTC) DETECTING CRITERIA

GENERAL DESCRIPTION

5. DIAGNOSTIC METHOD

• Abnormality Judgment

Judge NG when the continuous time of completing the malfunction criteria below becomes more than 15 seconds.

• Judgment Value

Malfunction Criteria	Threshold Value
Fuel tank pressure	< -7.33 kPa (-55 mmHg, -2.17 inHg)

Time Needed for Diagnosis: 15 seconds

Malfunction Indicator Light Illumination: Illuminates as soon as malfunction occurs.

• Normality Judgment

Judge OK when the malfunction criteria below is completed.

• Judgment Value

Malfunction Criteria	Threshold Value
Fuel tank pressure	≥ -7.33 kPa (-55 mmHg, -2.17 inHg)
Feedback lambda coefficient	≥ 0.9

6. DTC CLEAR CONDITION

- When the OK idling cycle was completed 40 times in a row
- When "Clear Memory" was performed

7. MALFUNCTION INDICATOR LIGHT CLEAR CONDITION

- When the OK driving cycle was completed 3 times in a row
- When "Clear Memory" was performed

8. FAIL SAFE

Purge control solenoid valve control: Purge fixation mode is prohibited.

9. ECM OPERATION AT DTC SETTING

Memorize the freeze frame data. (For test mode \$02)

DIAGNOSTIC TROUBLE CODE (DTC) DETECTING CRITERIA

GENERAL DESCRIPTION

BF:DTC P0453 — EVAPORATIVE EMISSION CONTROL SYSTEM PRESSURE SENSOR HIGH INPUT —

1. OUTLINE OF DIAGNOSIS

Detect the breaking/shortage of the fuel tank pressure sensor.
Judge NG when out of the standard value.

2. COMPONENT DESCRIPTION

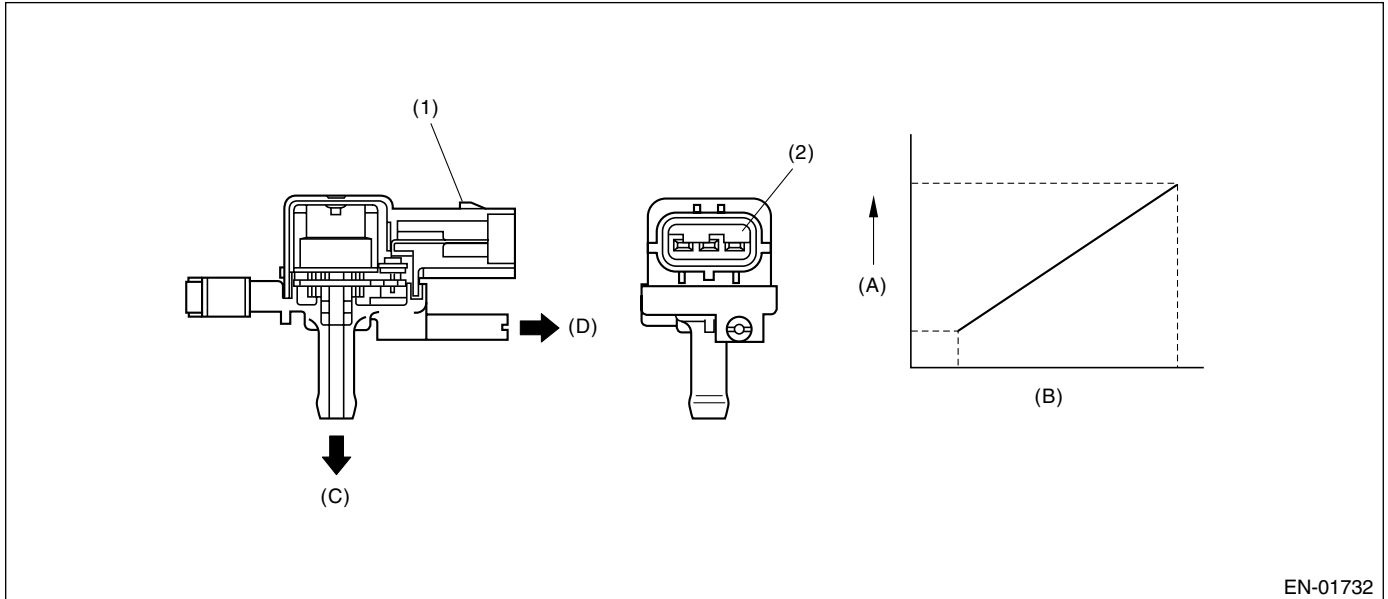

EN-01732

(1) Connector

(2) Terminal

(A) Output voltage

(B) Input voltage

(C) To fuel tank

(D) To atmospheric pressure switching solenoid

3. ENABLE CONDITION

Secondary Parameters	Enable Conditions
Continuous time when all conditions are completed.	≥ 5 seconds
Vehicle speed	≥ 2 km/h (1.24 MPH)
All conditions of EVAP canister purge	Complete
Evaporation gas density learning value	≤ 0.08
Main feedback compensation coefficient	≥ 0.9
Battery voltage	≥ 10.9 V

4. GENERAL DRIVING CYCLE

Perform the diagnosis continuously when purging.

DIAGNOSTIC TROUBLE CODE (DTC) DETECTING CRITERIA

GENERAL DESCRIPTION

5. DIAGNOSTIC METHOD

• Abnormality Judgment

Judge NG when the continuous time until completing the malfunction criteria below becomes more than 15 seconds.

• Judgment Value

Malfunction Criteria	Threshold Value
Fuel tank pressure	≥ 7.33 kPa (55 mmHg, 2.17 inHg)
Fuel temperature	$< 35^{\circ}\text{C}$ (95°F)
Atmospheric pressure	≥ 75.1 kPa (563 mmHg, 22.2 inHg)

Time Needed for Diagnosis: 15 seconds

Malfunction Indicator Light Illumination: Illuminates as soon as malfunction occurs.

• Normality Judgment

Judge OK when the malfunction criteria below is completed.

• Judgment Value

Malfunction Criteria	Threshold Value
Fuel tank pressure	< 7.33 kPa (55 mmHg, 2.17 inHg)

6. DTC CLEAR CONDITION

- When the OK idling cycle was completed 40 times in a row
- When "Clear Memory" was performed

7. MALFUNCTION INDICATOR LIGHT CLEAR CONDITION

- When the OK driving cycle was completed 3 times in a row
- When "Clear Memory" was performed

8. FAIL SAFE

Purge control solenoid valve control: Purge fixation mode is prohibited.

9. ECM OPERATION AT DTC SETTING

Memorize the freeze frame data. (For test mode \$02)

DIAGNOSTIC TROUBLE CODE (DTC) DETECTING CRITERIA

GENERAL DESCRIPTION

BG:DTC P0456 — EVAPORATIVE EMISSION CONTROL SYSTEM LEAK DETECTED (VERY SMALL LEAK) —

1. OUTLINE OF DIAGNOSIS

For detecting conditions, refer to DTC P0442 EVAPORATIVE EMISSION CONTROL SYSTEM LEAK DETECTED (SMALL LEAK). <Ref. to GD(H4DOTC)-128, DTC P0442 — EVAPORATIVE EMISSION CONTROL SYSTEM LEAK DETECTED (SMALL LEAK) —.>

BH:DTC P0457 — EVAPORATIVE EMISSION CONTROL SYSTEM LEAK DETECTED (FUEL CAP LOOSE/OFF) —

1. OUTLINE OF DIAGNOSIS

For detecting conditions, refer to DTC P0442 EVAPORATIVE EMISSION CONTROL SYSTEM LEAK DETECTED (SMALL LEAK). <Ref. to GD(H4DOTC)-128, DTC P0442 — EVAPORATIVE EMISSION CONTROL SYSTEM LEAK DETECTED (SMALL LEAK) —.>

DIAGNOSTIC TROUBLE CODE (DTC) DETECTING CRITERIA

GENERAL DESCRIPTION

MEMO:

DIAGNOSTIC TROUBLE CODE (DTC) DETECTING CRITERIA

GENERAL DESCRIPTION

BI: DTC P0458 — EVAPORATIVE EMISSION CONTROL SYSTEM PURGE CONTROL VALVE CIRCUIT LOW —

1. OUTLINE OF DIAGNOSIS

Detect open or short circuit of purge control solenoid valve.
Judge NG when ECM output level is different from actual terminal level.

2. COMPONENT DESCRIPTION

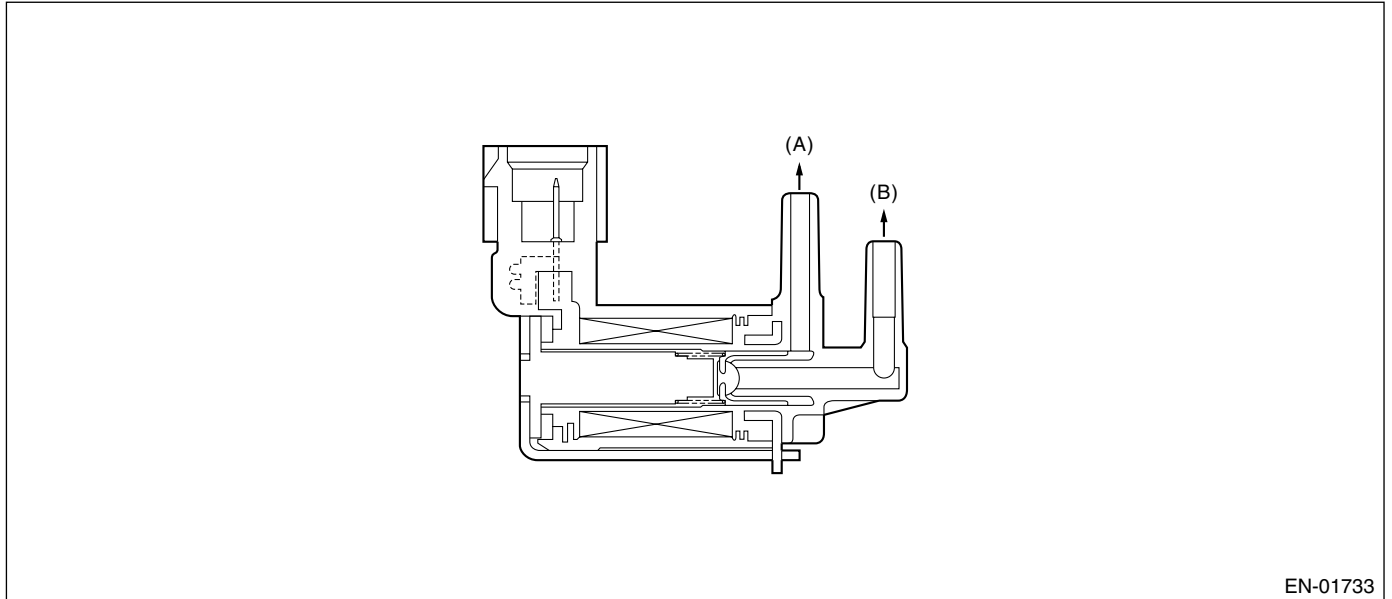

(A) To canister

(B) To intake manifold

3. ENABLE CONDITION

Secondary Parameters	Enable Conditions
Ignition switch	ON
Battery voltage	≥ 10.9 V
After starting engine	1 second or more

4. GENERAL DRIVING CYCLE

Always perform the diagnosis after starting the engine.

DIAGNOSTIC TROUBLE CODE (DTC) DETECTING CRITERIA

GENERAL DESCRIPTION

5. DIAGNOSTIC METHOD

• Abnormality Judgment

Judge NG when the malfunction criteria below are completed.

• Judgment Value

Malfunction Criteria	Threshold Value
Continuous time of completing criteria below.	≥ 2.5 seconds
Duty ratio of 'ON'	$< 75\%$
Terminal output voltage	Low

Time Needed for Diagnosis: 2.5 seconds

Malfunction Indicator Light Illumination: Illuminates as soon as malfunction occurs.

• Normality Judgment

Judge OK and clear NG when the malfunction criterion below is completed.

• Judgment Value

Malfunction Criteria	Threshold Value
Terminal output voltage	High

6. DTC CLEAR CONDITION

- When the OK idling cycle was completed 40 times in a row
- When "Clear Memory" was performed

7. MALFUNCTION INDICATOR LIGHT CLEAR CONDITION

- When the OK driving cycle was completed 3 times in a row
- When "Clear Memory" was performed

8. FAIL SAFE

None

9. ECM OPERATION AT DTC SETTING

Memorize the freeze frame data. (For test mode \$02)

DIAGNOSTIC TROUBLE CODE (DTC) DETECTING CRITERIA

GENERAL DESCRIPTION

BJ:DTC P0459 — EVAPORATIVE EMISSION CONTROL SYSTEM PURGE CONTROL VALVE CIRCUIT HIGH —

1. OUTLINE OF DIAGNOSIS

Detect open or short circuit of purge control solenoid valve.
Judge NG when ECM output level is different from actual terminal level.

2. COMPONENT DESCRIPTION

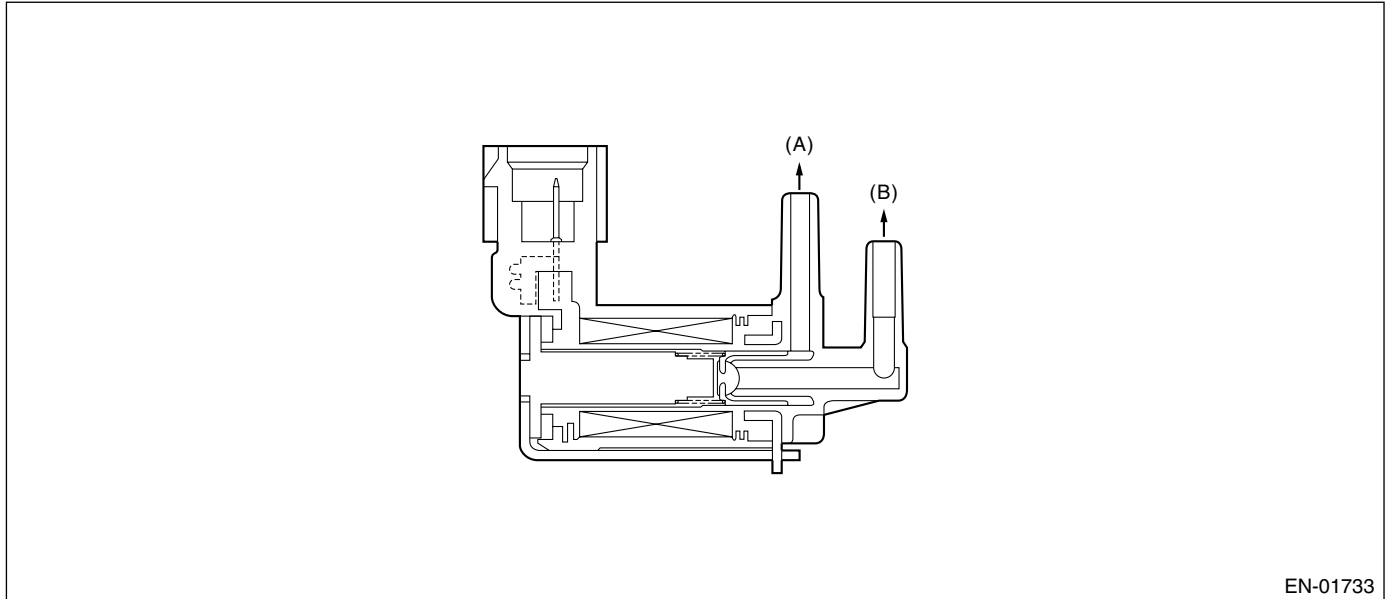

(A) To canister

(B) To intake manifold

3. ENABLE CONDITION

Secondary Parameters	Enable Conditions
Ignition switch	ON
Battery voltage	≥ 10.9 V
After starting engine	1 second or more

4. GENERAL DRIVING CYCLE

Always perform the diagnosis after starting the engine.

DIAGNOSTIC TROUBLE CODE (DTC) DETECTING CRITERIA

GENERAL DESCRIPTION

5. DIAGNOSTIC METHOD

• Abnormality Judgment

Judge NG when the malfunction criteria below are completed.

• Judgment Value

Malfunction Criteria	Threshold Value
Continuous time of completing criteria below.	≥ 2.5 seconds
Duty ratio of 'ON'	$\geq 25\%$
Terminal output voltage	High

Time Needed for Diagnosis: 2.5 seconds

Malfunction Indicator Light Illumination: Illuminates when malfunction occurs in 2 continuous driving cycles.

• Normality Judgment

Judge OK and clear NG when the malfunction criterion below is completed.

• Judgment Value

Malfunction Criteria	Threshold Value
Terminal output voltage	Low

6. DTC CLEAR CONDITION

- When the OK idling cycle was completed 40 times in a row
- When "Clear Memory" was performed

7. MALFUNCTION INDICATOR LIGHT CLEAR CONDITION

- When the OK driving cycle was completed 3 times in a row
- When "Clear Memory" was performed

8. FAIL SAFE

None

9. ECM OPERATION AT DTC SETTING

Memorize the freeze frame data. (For test mode \$02)

DIAGNOSTIC TROUBLE CODE (DTC) DETECTING CRITERIA

GENERAL DESCRIPTION

BK:DTC P0461 — FUEL LEVEL SENSOR CIRCUIT RANGE/PERFORMANCE —

1. OUTLINE OF DIAGNOSIS

Detect the malfunction of fuel level sensor output property.

Judge NG when the fuel level does not vary whereas it seemed to vary be in a usual driving speed.

2. COMPONENT DESCRIPTION

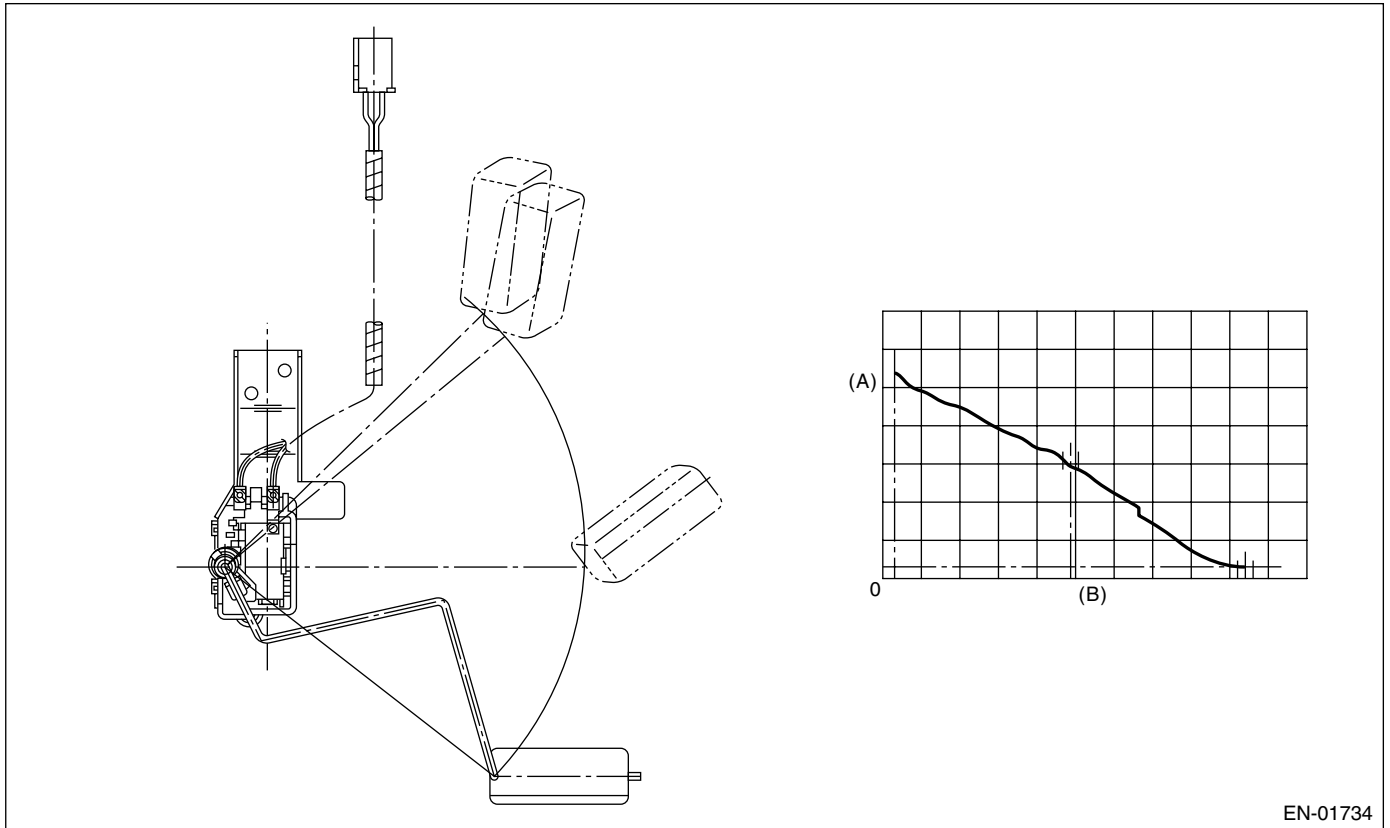

(A) Fuel level (L)

(B) Resistance (Ω)

3. ENABLE CONDITION

Secondary Parameters	Enable Conditions
None	

4. GENERAL DRIVING CYCLE

Always perform the diagnosis continuously.

DIAGNOSTIC TROUBLE CODE (DTC) DETECTING CRITERIA

GENERAL DESCRIPTION

5. DIAGNOSTIC METHOD

• Abnormality Judgment

Judge NG when the malfunction criteria below are completed.

• Judgment Value

Malfunction Criteria	Threshold Value
Accumulated amount of intake air	> 331 kg (729.7 lb)
Max.– Min. fuel level output	< 2.6 ℓ (0.69 US gal, 0.57 Imp gal)
Battery voltage	≥ 10.9 V
After starting engine	More than 10 seconds

Time Needed for Diagnosis: To be determined.

Malfunction Indicator Light Illumination: Illuminates when malfunction occurs in 2 continuous driving cycles.

• Normality Judgment

Judge OK and clear the NG when the malfunction criteria below are completed.

• Judgment Value

Malfunction Criteria	Threshold Value
Accumulated amount of intake air	> 331 kg (729.7 lb)
Max.– Min. fuel level output	≥ 2.6 ℓ (0.69 US gal, 0.57 Imp gal)
Battery voltage	≥ 10.9 V
After starting engine	More than 10 seconds

6. DTC CLEAR CONDITION

- When the OK idling cycle was completed 40 times in a row
- When “Clear Memory” was performed

7. MALFUNCTION INDICATOR LIGHT CLEAR CONDITION

- When the OK driving cycle was completed 3 times in a row
- When “Clear Memory” was performed

8. FAIL SAFE

None

9. ECM OPERATION AT DTC SETTING

Memorize the freeze frame data. (For test mode \$02)

DIAGNOSTIC TROUBLE CODE (DTC) DETECTING CRITERIA

GENERAL DESCRIPTION

BL:DTC P0462 — FUEL LEVEL SENSOR CIRCUIT LOW INPUT —

1. OUTLINE OF DIAGNOSIS

Detect the open or short circuit of fuel level sensor. Judge NG when out of the standard value.

2. COMPONENT DESCRIPTION

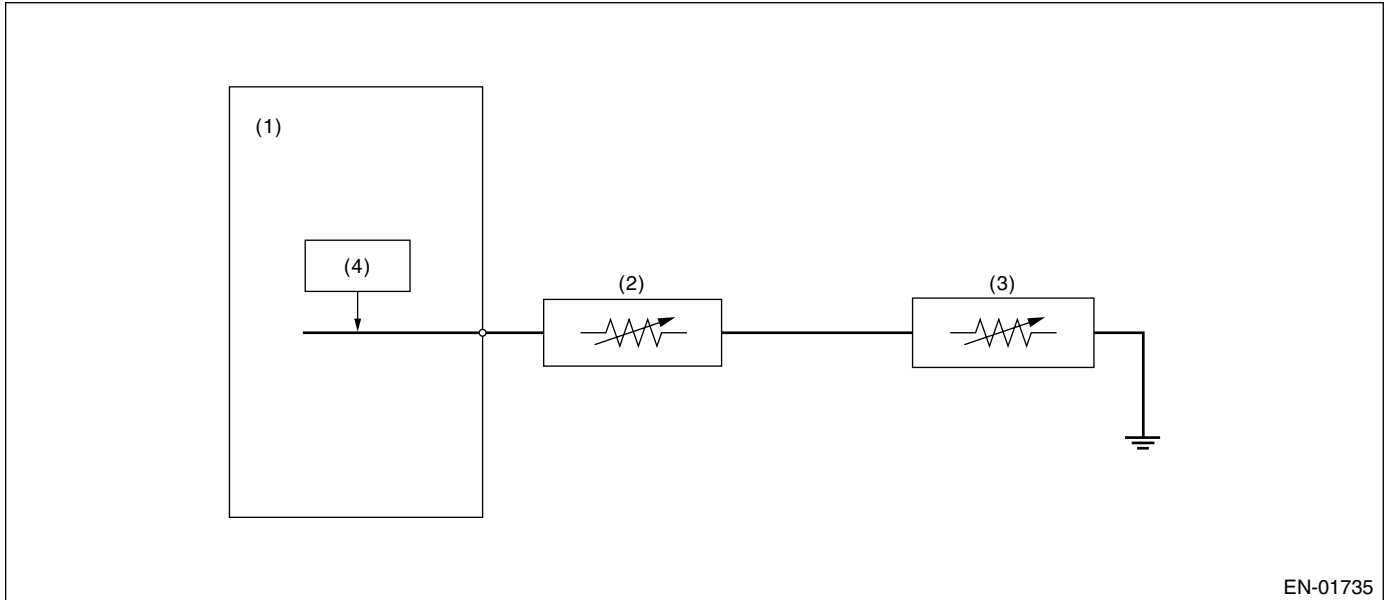

- (1) Engine control module (ECM)
- (2) Fuel level sensor
- (3) Fuel sub level sensor
- (4) Detecting circuit

3. ENABLE CONDITION

Secondary Parameters	Enable Conditions
None	

4. GENERAL DRIVING CYCLE

Always perform the diagnosis continuously

DIAGNOSTIC TROUBLE CODE (DTC) DETECTING CRITERIA

GENERAL DESCRIPTION

5. DIAGNOSTIC METHOD

• Abnormality Judgment

Judge NG when the continuous time of completing the malfunction criteria below becomes more than the time needed for diagnosis (2.5 seconds).

• Judgment Value

Malfunction Criteria	Threshold Value
Ignition switch	ON
Battery voltage	≥ 10.9 V
After starting engine	3 seconds or more
Output voltage	< 0.02 V

Time Needed for Diagnosis: 2.5 seconds

Malfunction Indicator Light Illumination: Illuminates when malfunction occurs in 2 continuous driving cycles.

• Normality Judgment

Judge OK and clear the NG when the malfunction criteria below are completed.

• Judgment Value

Malfunction Criteria	Threshold Value
Ignition switch	ON
Battery voltage	≥ 10.9 V
After starting engine	3 seconds or more
Output voltage	≥ 0.02 V

6. DTC CLEAR CONDITION

- When the OK idling cycle was completed 40 times in a row
- When "Clear Memory" was performed

7. MALFUNCTION INDICATOR LIGHT CLEAR CONDITION

- When the OK driving cycle was completed 3 times in a row
- When "Clear Memory" was performed

8. FAIL SAFE

None

9. ECM OPERATION AT DTC SETTING

Memorize the freeze frame data. (For test mode \$02)

DIAGNOSTIC TROUBLE CODE (DTC) DETECTING CRITERIA

GENERAL DESCRIPTION

BM:DTC P0463 — FUEL LEVEL SENSOR CIRCUIT HIGH INPUT —

1. OUTLINE OF DIAGNOSIS

Detect the open or short circuit of fuel level sensor. Judge NG when out of the standard value.

2. COMPONENT DESCRIPTION

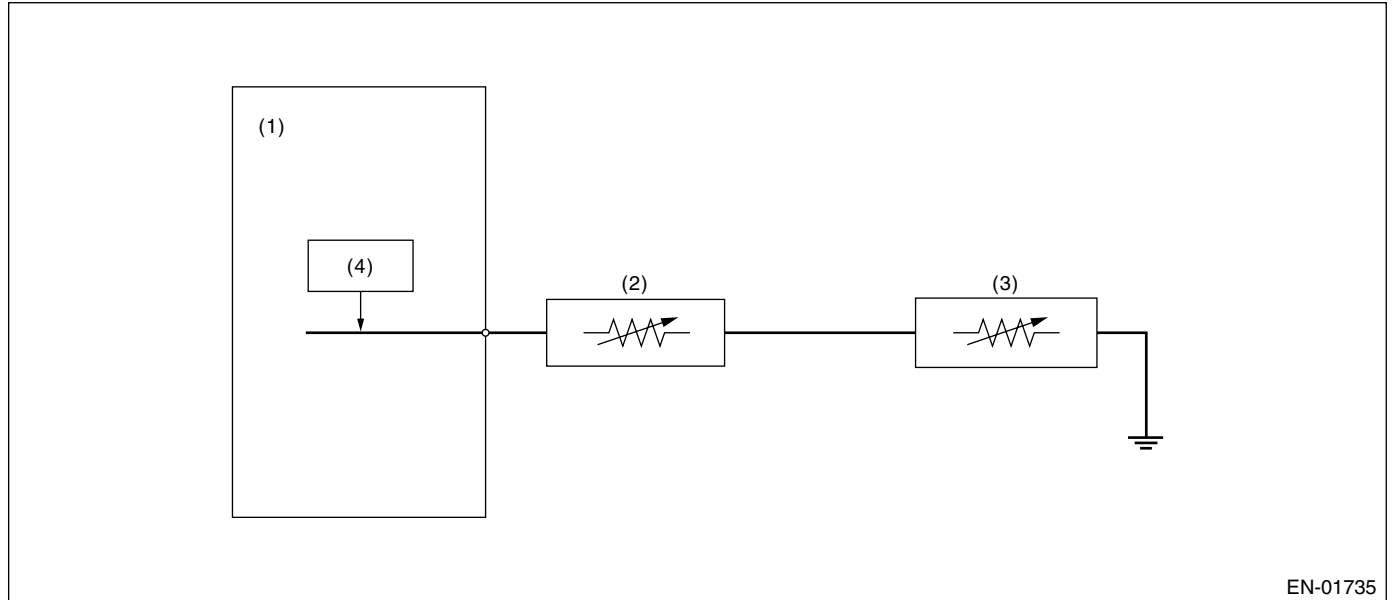

- (1) Engine control module (ECM)
- (2) Fuel level sensor
- (3) Fuel sub level sensor
- (4) Detecting circuit

3. ENABLE CONDITION

Secondary Parameters	Enable Conditions
None	

4. GENERAL DRIVING CYCLE

Always perform the diagnosis continuously.

DIAGNOSTIC TROUBLE CODE (DTC) DETECTING CRITERIA

GENERAL DESCRIPTION

5. DIAGNOSTIC METHOD

• Abnormality Judgment

Judge NG when the continuous time of completing the malfunction criteria below becomes more than the time needed for diagnosis (10 seconds).

• Judgment Value

Malfunction Criteria	Threshold Value
Ignition switch	ON
Battery voltage	≥ 10.9 V
After starting engine	3 seconds or more
Output voltage	≥ 4.95 V

Time Needed for Diagnosis: 10 second

Malfunction Indicator Light Illumination: Illuminates when malfunction occurs in 2 continuous driving cycles.

• Normality Judgment

Judge OK and clear the NG when the malfunction criteria below are completed.

• Judgment Value

Malfunction Criteria	Threshold Value
Ignition switch	ON
Battery voltage	≥ 10.9 V
After starting engine	3 seconds or more
Output voltage	< 4.95 V

6. DTC CLEAR CONDITION

- When the OK idling cycle was completed 40 times in a row
- When "Clear Memory" was performed

7. MALFUNCTION INDICATOR LIGHT CLEAR CONDITION

- When the OK driving cycle was completed 3 times in a row
- When "Clear Memory" was performed

8. FAIL SAFE

None

9. ECM OPERATION AT DTC SETTING

Memorize the freeze frame data. (For test mode \$02)

DIAGNOSTIC TROUBLE CODE (DTC) DETECTING CRITERIA

GENERAL DESCRIPTION

BN:DTC P0464 — FUEL LEVEL SENSOR CIRCUIT INTERMITTENT —

1. OUTLINE OF DIAGNOSIS

Detect the malfunction of unstable output from fuel level sensor caused by noise.

Judge NG when the max. value and cumulative value of output voltage variation of fuel level sensor is larger than the threshold value.

2. ENABLE CONDITION

Secondary Parameters	Enable Conditions
Engine speed	≥ 500 rpm
After starting engine	1 second or more
Ignition switch	ON
Battery voltage	> 10.9 V
Idle switch	ON
Fuel level	9 ↔ 51 ℓ (2.4 ↔ 13.4 US gal, 1.98 ↔ 11.2 Imp gal)
Vehicle speed = 0 km/h (0 MPH)	10 seconds or more

3. GENERAL DRIVING CYCLE

- Perform the diagnosis continuously in idling condition.
- Pay attention to the fuel level.

DIAGNOSTIC TROUBLE CODE (DTC) DETECTING CRITERIA

GENERAL DESCRIPTION

4. DIAGNOSTIC METHOD

Calculate the Max. value (delvfm_x) and cumulative value (sumvfl) of output voltage variation of fuel level sensor during 12.8 seconds. Judge it normal when both max. and cumulative values are not over the threshold value. Otherwise, when either of them is over the threshold value, count the diagnosis counter up. And judge NG if the counter indicated 6 counts.

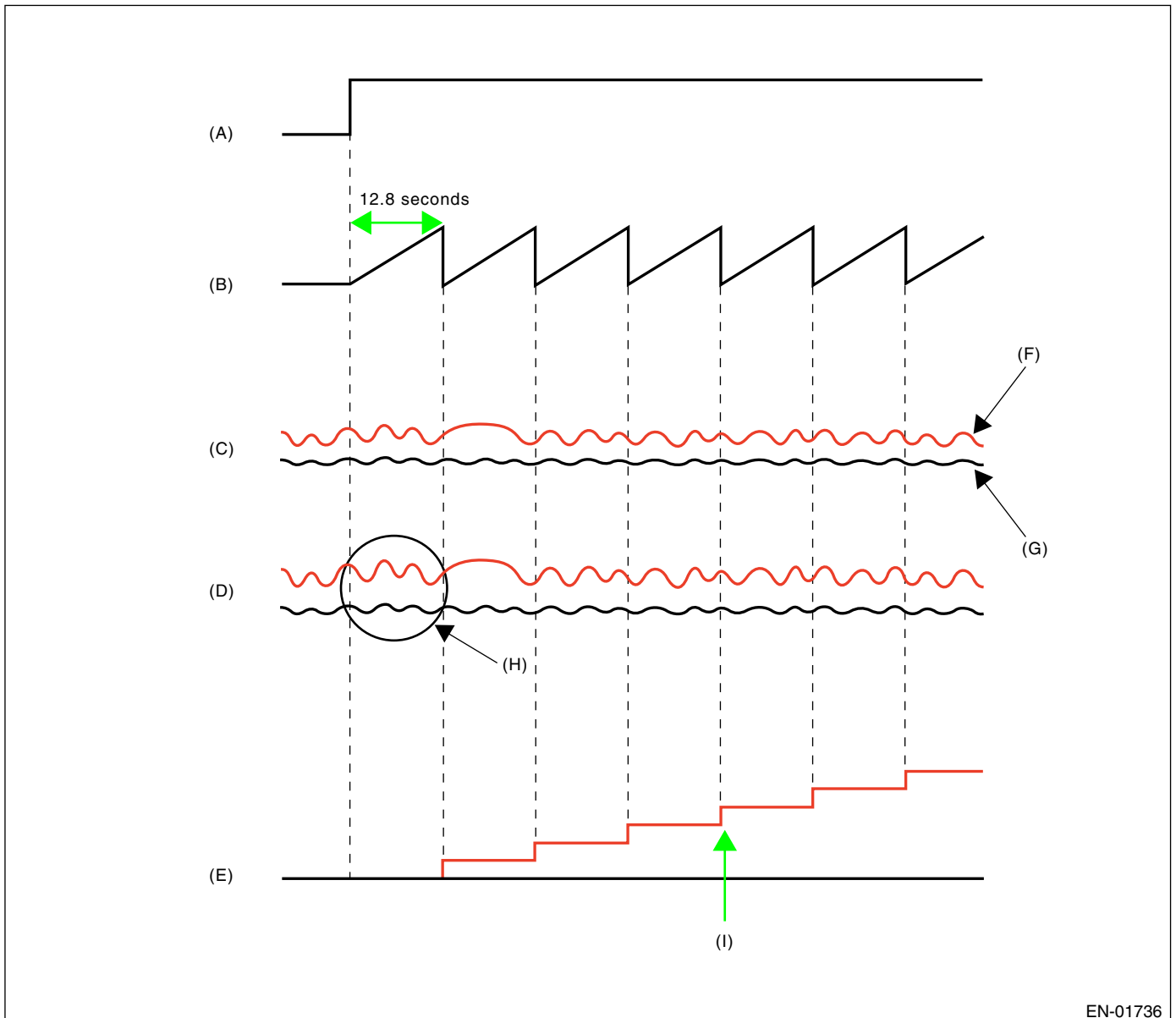

EN-01736

(A) Diagnosis condition

(E) Diagnosis counter

(H) Calculate the Max. value (delvfm_x) and the cumulative value (sumvfl)

(B) Diagnosis time

(F) Malfunction

(I) NG at 4 counts

(C) Fuel level sensor at idle

(G) Normal

(D) Amount of fuel level output voltage variation

• Abnormality Judgment

Judge NG when the malfunction criteria below are completed.

DIAGNOSTIC TROUBLE CODE (DTC) DETECTING CRITERIA

GENERAL DESCRIPTION

• Judgment Value

Malfunction Criteria	Threshold Value
Integrated times of the condition reaching follows, DELFLMAX \geq 0.2 V or SUMFL \geq 19.2 V where, DELFLMAX is Max. deviation of sensor output during 12.8 seconds. SUMFL is integrated value of sensor output deviation during 12.8 seconds.	\geq 4 times

Do not count the diagnosis counter up when the following conditions are completed during 12.8 seconds.

Max – Min of tank pressure during 12.8 seconds	\geq 0.05 kPa (0.375 mmHg, 0.02 inHg)
Max – Min of battery voltage during 12.8 seconds	\geq 0.27 V

Time Needed for Diagnosis: 12.8 seconds \times 4 times

Malfunction Indicator Light Illumination: Illuminates when malfunction occurs in 2 continuous driving cycles.

• Normality Judgment

Judge OK and clear the NG when the malfunction criteria below are completed.

• Judgment Value

Malfunction Criteria	Threshold Value
DELFLMAX	$<$ 0.2 V
SUMFL	$<$ 15 V
Where, DELFLMAX is Max. deviation of sensor output during 12.8 seconds. SUMFL is integrated value of sensor output deviation during 12.8 seconds.	

5. DTC CLEAR CONDITION

- When the OK idling cycle was completed 40 times in a row
- When "Clear Memory" was performed

6. MALFUNCTION INDICATOR LIGHT CLEAR CONDITION

- When the OK driving cycle was completed 3 times in a row
- When "Clear Memory" was performed

7. FAIL SAFE

None

8. ECM OPERATION AT DTC SETTING

Memorize the freeze frame data. (For test mode \$02)

DIAGNOSTIC TROUBLE CODE (DTC) DETECTING CRITERIA

GENERAL DESCRIPTION

BO:DTC P0483 — COOLING FAN RATIONALITY CHECK —

1. OUTLINE OF DIAGNOSIS

Detect the function abnormality of the radiator fan.

Judge NG when the engine coolant temperature slowly decreases even when the radiator fan is rotating.

2. ENABLE CONDITION

Diagnostic enable condition is completed if the radiator fan changes from OFF to ON when all of the conditions below are completed. When one of the conditions below is not completed, the diagnostic enable condition is not completed.

Secondary Parameters	Enable Conditions
Engine Speed	500 — 900 rpm
Idle switch	ON
Vehicle speed	0 km/h (0 MPH)
Battery voltage	≥ 10.9 V

3. GENERAL DRIVING CYCLE

Perform the diagnosis continuously when idling.

4. DIAGNOSTIC METHOD

• Abnormality Judgment

Judge NG when the continuous time of completing the malfunction criteria below becomes more than 5 minutes.

• Judgment Value

Malfunction Criteria	Threshold Value
Engine coolant temperature	≥ 98°C (208°F)
Radiator fan	OFF → ON
Engine coolant temperature	not reduce

Time Needed for Diagnosis: 5 minutes

Malfunction Indicator Light Illumination: Illuminates when malfunction occurs in 2 continuous driving cycles.

• Normality Judgment

Judge OK and clear NG when the malfunction criteria below are completed.

• Judgment Value

Malfunction Criteria	Threshold Value
Radiator fan	OFF → ON
Engine coolant temperature	reduce

5. DTC CLEAR CONDITION

- When the OK idling cycle was completed 40 times in a row
- When “Clear Memory” was performed

6. MALFUNCTION INDICATOR LIGHT CLEAR CONDITION

- When the OK driving cycle was completed 3 times in a row
- When “Clear Memory” was performed

7. FAIL SAFE

None

8. ECM OPERATION AT DTC SETTING

Memorize the freeze frame data. (For test mode \$02)

DIAGNOSTIC TROUBLE CODE (DTC) DETECTING CRITERIA

GENERAL DESCRIPTION

BP:DTC P0502 — VEHICLE SPEED SENSOR CIRCUIT LOW INPUT —

1. OUTLINE OF DIAGNOSIS

Detect the open or short circuit of vehicle speed sensor.

Judge NG when low vehicle speed (0 km/h (0 MPH)) remains whereas it seemed to be in a usual driving speed.

2. ENABLE CONDITION

Secondary Parameters	Enable Conditions
Engine speed	< 4000 rpm
Fuel cut in decel.	In operation
Battery voltage	≥ 10.9 V

3. GENERAL DRIVING CYCLE

Perform the diagnosis continuously during fuel cut in deceleration at engine speed of 4000 rpm or less.

4. DIAGNOSTIC METHOD

• Abnormality Judgment

Judge NG when the continuous time of completing the malfunction criteria below becomes more than 4 seconds.

• Judgment Value

Malfunction Criteria	Threshold Value
Vehicle speed	< 1

Time Needed for Diagnosis: 4 seconds

Malfunction Indicator Light Illumination: Illuminates as soon as the malfunction occurs.

• Normality Judgment

Judge OK and clear the NG when all malfunction criteria below are completed.

• Judgment Value

Malfunction Criteria	Threshold Value
Vehicle speed	≥ 1
Starter switch	OFF
Time after starter switch ON → OFF	≥ 3 seconds

5. DTC CLEAR CONDITION

- When the OK idling cycle was completed 40 times in a row
- When “Clear Memory” was performed

6. MALFUNCTION INDICATOR LIGHT CLEAR CONDITION

- When the OK driving cycle was completed 3 times in a row
- When “Clear Memory” was performed

7. FAIL SAFE

- Accelerator sensor signal process: Not allowed all closed points learning.
- Vehicle speed sensor signal process: Vehicle speed = 10 km/h (6 MPH)
- Fuel cut control: Not allowed vehicle speed 0 km/h (0 MPH) fuel cut. Normally the high vehicle speed fuel cut performs on “and” of vehicle speed condition and engine speed, but perform the fuel cut only on engine speed condition (4,800 rpm or more).
- ISC control: Set the open loop compensation to specified value (1 g (0.04 oz)/s). Not allowed ISC feedback volume calculation.
- Air conditioner control: Not allowed air conditioner cut at accelerating.
- Radiator fan control: Hi drive both main/sub.
- Judge gear ratio: Control as gear fixed on 6th.
- Tumble generator valve control: Open the tumble generator valve.

DIAGNOSTIC TROUBLE CODE (DTC) DETECTING CRITERIA

GENERAL DESCRIPTION

8. ECM OPERATION AT DTC SETTING

Memorize the freeze frame data. (For test mode \$02)

DIAGNOSTIC TROUBLE CODE (DTC) DETECTING CRITERIA

GENERAL DESCRIPTION

BQ:DTC P0503 — VEHICLE SPEED SENSOR INTERMITTENT/ERRATIC/HIGH —

1. OUTLINE OF DIAGNOSIS

Detect the open or short circuit of vehicle speed sensor.

Judge NG when high vehicle speed (300 km/h (186 MPH) or more) remains whereas it seemed to be in a usual driving speed.

2. ENABLE CONDITION

Secondary Parameters	Enable Conditions
Engine speed	< 4000 rpm
Fuel cut in decel.	In operation
Battery voltage	≥ 10.9 V

3. GENERAL DRIVING CYCLE

Perform the diagnosis continuously during fuel cut in deceleration at engine speed of 4000 rpm or less.

4. DIAGNOSTIC METHOD

• Abnormality Judgment

Judge NG when the cumulative time of completing the malfunction criteria below becomes more than 4 seconds.

• Judgment Value

Malfunction Criteria	Threshold Value
Vehicle speed	≥ 300

Time Needed for Diagnosis: 4 seconds

Malfunction Indicator Light Illumination: Illuminates as soon as the malfunction occurs.

• Normality Judgment

Judge OK and clear the NG when all malfunction criteria below are completed.

• Judgment Value

Malfunction Criteria	Threshold Value
Vehicle speed	< 300
Starter switch	OFF
Time after starter switch ON → OFF	≥ 3 seconds

5. DTC CLEAR CONDITION

- When the OK idling cycle was completed 40 times in a row
- When "Clear Memory" was performed

6. MALFUNCTION INDICATOR LIGHT CLEAR CONDITION

- When the OK driving cycle was completed 3 times in a row
- When "Clear Memory" was performed

7. FAIL SAFE

- Accelerator sensor signal process: Not allowed all closed points learning.
- Vehicle speed sensor signal process: Vehicle speed = 10 km/h (6 MPH)
- Fuel cut control: Not allowed vehicle speed 0 km/h (0 MPH) fuel cut. Normally the high vehicle speed fuel cut performs on "and" of vehicle speed condition and engine speed, but perform the fuel cut only on engine speed condition (4,800 rpm or more).
- ISC control: Set the open loop compensation to specified value (1 g (0.04 oz)/s). Not allowed ISC feedback volume calculation.
- Air conditioner control: Not allowed air conditioner cut at accelerating.
- Radiator fan control: Hi drive both main/sub.
- Judge gear ratio: Control as gear fixed on 6th.
- Tumble generator valve control: Open the tumble generator valve.

DIAGNOSTIC TROUBLE CODE (DTC) DETECTING CRITERIA

GENERAL DESCRIPTION

8. ECM OPERATION AT DTC SETTING

Memorize the freeze frame data. (For test mode \$02)

DIAGNOSTIC TROUBLE CODE (DTC) DETECTING CRITERIA

GENERAL DESCRIPTION

BR:DTC P0506 — IDLE CONTROL SYSTEM RPM LOWER THAN EXPECTED —

1. OUTLINE OF DIAGNOSIS

Detect the malfunction that actual engine speed is not close to target engine speed during idling. Judge NG when actual engine speed is not close to target engine speed during idling.

2. ENABLE CONDITION

Secondary Parameters	Enable Conditions
Engine coolant temperature	≥ 75°C (167°F)
Battery voltage	≥ 10.9 V
Atmospheric pressure	> 75.1 kPa (563 mmHg, 22.2 inHg)
Fuel level	≥ 9 ℓ (2.38 US gal, 1.98 Imp gal)
After starting engine	10 seconds or more
Feedback in ISC	In operation
Measured lambda	0.90 ←→ 1.1
After air condition switching ON-OFF, OFF-ON	5 seconds or more
After in-manifold pressure change more than 4 kPa (30 mmHg, 1.2 inHg)	> 5 seconds
After neutral switch ON-OFF event	> 5 seconds
Vehicle speed	0 km/h (0 MPH)

3. GENERAL DRIVING CYCLE

Perform the diagnosis continuously during idling, 10 seconds after starting and warming up.

4. DIAGNOSTIC METHOD

• Abnormality Judgment

Judge NG when the cumulative time of completing the malfunction criterion below becomes more than the time needed for diagnosis (10 seconds × 3 times).

• Judgment Value

Malfunction Criteria	Threshold Value
Actual – target engine speed	< –100 rpm
Feedback correction for idle air control solenoid valve	Max.

Time Needed for Diagnosis: 10 seconds × 3 times

Malfunction Indicator Light Illumination: Illuminates when malfunction occurs in 2 continuous driving cycles.

• Normality Judgment

Judge OK and clear NG when the continuous time of completing the malfunction criterion below becomes more than the time needed for diagnosis (10 seconds).

• Judgment Value

Malfunction Criteria	Threshold Value
Actual – target engine speed	≥ –100 rpm

5. DTC CLEAR CONDITION

- When the OK idling cycle was completed 40 times in a row
- When “Clear Memory” was performed

6. MALFUNCTION INDICATOR LIGHT CLEAR CONDITION

- When the OK driving cycle was completed 3 times in a row
- When “Clear Memory” was performed

DIAGNOSTIC TROUBLE CODE (DTC) DETECTING CRITERIA

GENERAL DESCRIPTION

7. FAIL SAFE

Judgment of heavy fuel: Not allowed to make the judgment of heavy fuel.

Knock compensation:

- Knock compensation final retard/advance value: Knock compensation value + Total learning compensation value + Partial learning compensation value
- AT normal: Knock compensation value = Fixed on 0°CA
- AT abnormal: Knock compensation value ≠ Fixed on 0°CA (Maximum 12°CA retard on knocking)
- Not allowed to refresh learning compensation coefficient
- Not allowed to calculate partial learning zone compensation value

8. ECM OPERATION AT DTC SETTING

Memorize the freeze frame data. (For test mode \$02)

DIAGNOSTIC TROUBLE CODE (DTC) DETECTING CRITERIA

GENERAL DESCRIPTION

BS:DTC P0507 — IDLE CONTROL SYSTEM RPM HIGHER THAN EXPECTED —

1. OUTLINE OF DIAGNOSIS

Detect the malfunction that actual engine speed is not close to target engine speed during idling.
Judge NG when actual engine speed is not close to target engine speed during idling.

2. ENABLE CONDITION

Secondary Parameters	Enable Conditions
Engine coolant temperature	≥ 75°C (167°F)
Battery voltage	≥ 10.9 V
Atmospheric pressure	> 75.1 kPa (563 mmHg, 22.2 inHg)
Fuel level	≥ 9 ℓ (2.38 US gal, 1.98 Imp gal)
After starting engine	10 seconds or more
Feedback in ISC	In operation
Lambda	0.90 ←→ 1.1
After air condition switching ON-OFF, OFF-ON	5 seconds or more
After in-manifold pressure change more than 4 kPa (30 mmHg, 1.2 inHg)	> 5 seconds
After neutral switch ON-OFF event	> 5 seconds
Vehicle speed	0 km/h (0 MPH)

3. GENERAL DRIVING CYCLE

Perform the diagnosis continuously during idling, 10 seconds after starting and warming up.

4. DIAGNOSTIC METHOD

• Abnormality Judgment

Judge NG when the continuous time of completing the malfunction criterion below becomes more than the time needed for diagnosis (10 seconds × 3 times).

• Judgment Value

Malfunction Criteria	Threshold Value
Actual – target eng. speed	≥ 200 rpm
Feedback correction for idle air control solenoid valve	Min.

Time Needed for Diagnosis: 10 seconds × 3 times

Malfunction Indicator Light Illumination: Illuminates when malfunction occurs in 2 continuous driving cycles.

• Normality Judgment

Judge OK and clear NG when the continuous time of completing the malfunction criterion below becomes more than the time needed for diagnosis (10 seconds).

• Judgment Value

Malfunction Criteria	Threshold Value
Actual – target eng. speed	< 200 rpm

5. DTC CLEAR CONDITION

- When the OK idling cycle was completed 40 times in a row
- When “Clear Memory” was performed

6. MALFUNCTION INDICATOR LIGHT CLEAR CONDITION

- When the OK driving cycle was completed 3 times in a row
- When “Clear Memory” was performed

DIAGNOSTIC TROUBLE CODE (DTC) DETECTING CRITERIA

GENERAL DESCRIPTION

7. FAIL SAFE

Judgment of heavy fuel: Not allowed to make the judgment of heavy fuel.

Knock compensation:

- Knock compensation final retard/advance value: Knock compensation value + Total learning compensation value + Partial learning compensation value
- AT normal: Knock compensation value = Fixed on 0°CA
- AT abnormal: Knock compensation value \neq Fixed on 0°CA (Maximum 12°CA retard on knocking)
- Not allowed to refresh learning compensation coefficient
- Not allowed to calculate partial learning zone compensation value

8. ECM OPERATION AT DTC SETTING

Memorize the freeze frame data. (For test mode \$02)

DIAGNOSTIC TROUBLE CODE (DTC) DETECTING CRITERIA

GENERAL DESCRIPTION

BT:DTC P0512 — STARTER REQUEST CIRCUIT —

1. OUTLINE OF DIAGNOSIS

Detect the open or short circuit of starter SW.

Judge ON NG when the starter SW signal remains to be on.

Judge OFF NG when the engine starts without starter experience.

2. ENABLE CONDITION

Secondary Parameters	Enable Conditions
None	

3. GENERAL DRIVING CYCLE

Always perform the diagnosis continuously.

4. DIAGNOSTIC METHOD

• Abnormality Judgment

Judge NG when the continuous time of completing the malfunction criteria below becomes more than 3 minutes.

• Judgment Value

Malfunction Criteria	Threshold Value
Engine speed	> 500 rpm
Starter OFF signal	Not detected
Battery voltage	> 8 V

Time Needed for Diagnosis: 180 seconds

Malfunction Indicator Light Illumination: Illuminates when malfunction occurs in 2 continuous driving cycles.

• Normality Judgment

Judge ON OK and clear the NG when the malfunction criteria below are completed.

• Judgment Value

Malfunction Criteria	Threshold Value
Starter SW	OFF
Battery voltage	> 8 V

5. DTC CLEAR CONDITION

- When the OK idling cycle was completed 40 times in a row
- When "Clear Memory" was performed

6. MALFUNCTION INDICATOR LIGHT CLEAR CONDITION

- When the OK driving cycle was completed 3 times in a row
- When "Clear Memory" was performed

7. FAIL SAFE

None

8. ECM OPERATION AT DTC SETTING

Memorize the freeze frame data. (For test mode \$02)

DIAGNOSTIC TROUBLE CODE (DTC) DETECTING CRITERIA

GENERAL DESCRIPTION

BU:DTC P0519 — IDLE CONTROL SYSTEM MALFUNCTION (FAIL-SAFE) —

1. OUTLINE OF DIAGNOSIS

Detect the malfunction that engine speed increases more than that in normal condition during idling.

2. ENABLE CONDITION

Secondary Parameters	Enable Conditions
Battery voltage	≥ 10.9 V
Feedback in ISC	In operation
Vehicle speed	< 4 km/h (2.49 MPH)
After engine starting	1 seconds or more

3. GENERAL DRIVING CYCLE

Always perform diagnosis at less than 4 km/h (2.49 MPH) of vehicle speed.

4. DIAGNOSTIC METHOD

• Abnormality Judgment

Judge NG when the continuous time until completing the all malfunction criteria below becomes more than the time needed for diagnosis (2 seconds).

• Judgment Value

Malfunction Criteria	Threshold Value
Engine speed – target eng. speed	≥ 1000 rpm
Feedback value for ISC	≤ 0
Engine speed change every 180 degree engine rev.	≥ -5 rpm

Time Needed for Diagnosis: 2 seconds

Malfunction Indicator Light Illumination: Illuminates as soon as malfunction occurs.

Judge OK and clear NG when the continuous time until completing the malfunction criteria below becomes more than the time needed for diagnosis (5 seconds).

• Normality Judgment

Judge OK and clear NG when the continuous time until completing the malfunction criteria below becomes more than the time needed for diagnosis (5 seconds).

• Judgment Value

Malfunction Criteria	Threshold Value
Engine speed – target eng. speed	< 200 rpm

5. DTC CLEAR CONDITION

- When the OK idling cycle was completed 40 times in a row
- When “Clear Memory” was performed

6. MALFUNCTION INDICATOR LIGHT CLEAR CONDITION

- When the OK driving cycle was completed 3 times in a row
- When “Clear Memory” was performed

7. FAIL SAFE

Fuel shut-off: Shut-off fuel for only #1 and #2 cylinder, or for all cylinder in accordance with vehicle speed, engine speed, throttle position

8. ECM OPERATION AT DTC SETTING

Memorize the freeze frame data. (For test mode \$02)

DIAGNOSTIC TROUBLE CODE (DTC) DETECTING CRITERIA

GENERAL DESCRIPTION

BV:DTC P0545 — EXHAUST GAS TEMPERATURE SENSOR CIRCUIT LOW-BANK 1 —

1. OUTLINE OF DIAGNOSIS

Detect the open or short circuit of exhaust temperature sensor.
Judge NG when out of the standard value.

2. COMPONENT DESCRIPTION

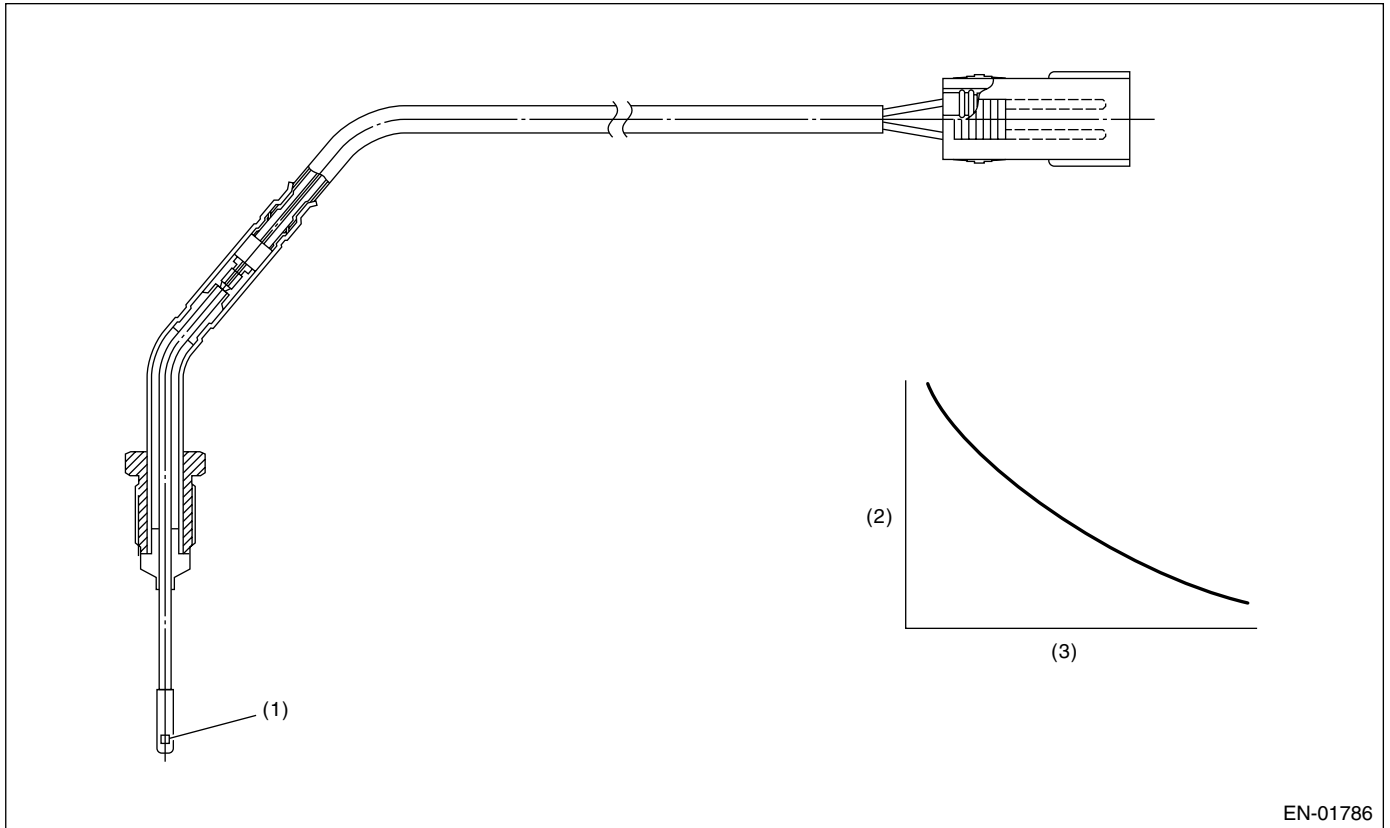

(1) Thermistor

(2) Resistance value (kΩ)

(3) Exhaust temperature °C (°F)

3. ENABLE CONDITION

Secondary Parameters	Enable Conditions
None	

4. GENERAL DRIVING CYCLE

Always perform the diagnosis continuously.

DIAGNOSTIC TROUBLE CODE (DTC) DETECTING CRITERIA

GENERAL DESCRIPTION

5. DIAGNOSTIC METHOD

• Abnormality Judgment

Judge NG when the continuous time of completing the malfunction criteria below becomes more than the time needed for diagnosis (5 seconds).

• Judgment Value

Malfunction Criteria	Threshold Value
Sensor output voltage	< 0.15 V
Amount of intake air	< 100 g (3.53 oz)/s

Time Needed for Diagnosis: 5 seconds

Malfunction Indicator Light Illumination: Illuminates as soon as the malfunction occurs.

• Normality Judgment

Judge OK and clear the NG when the malfunction criteria below are completed.

• Judgment Value

Malfunction Criteria	Threshold Value
Sensor output voltage	≥ 0.15 V

6. DTC CLEAR CONDITION

- When the OK idling cycle was completed 40 times in a row
- When "Clear Memory" was performed

7. MALFUNCTION INDICATOR LIGHT CLEAR CONDITION

- When the OK driving cycle was completed 3 times in a row
- When "Clear Memory" was performed

8. FAIL SAFE

None

9. ECM OPERATION AT DTC SETTING

Memorize the freeze frame data. (For test mode \$02)

DIAGNOSTIC TROUBLE CODE (DTC) DETECTING CRITERIA

GENERAL DESCRIPTION

BW:DTC P0546 — EXHAUST GAS TEMPERATURE SENSOR CIRCUIT HIGH-BANK 1 —

1. OUTLINE OF DIAGNOSIS

Detect the open or short circuit of exhaust temperature sensor.
Judge NG when out of the standard value.

2. COMPONENT DESCRIPTION

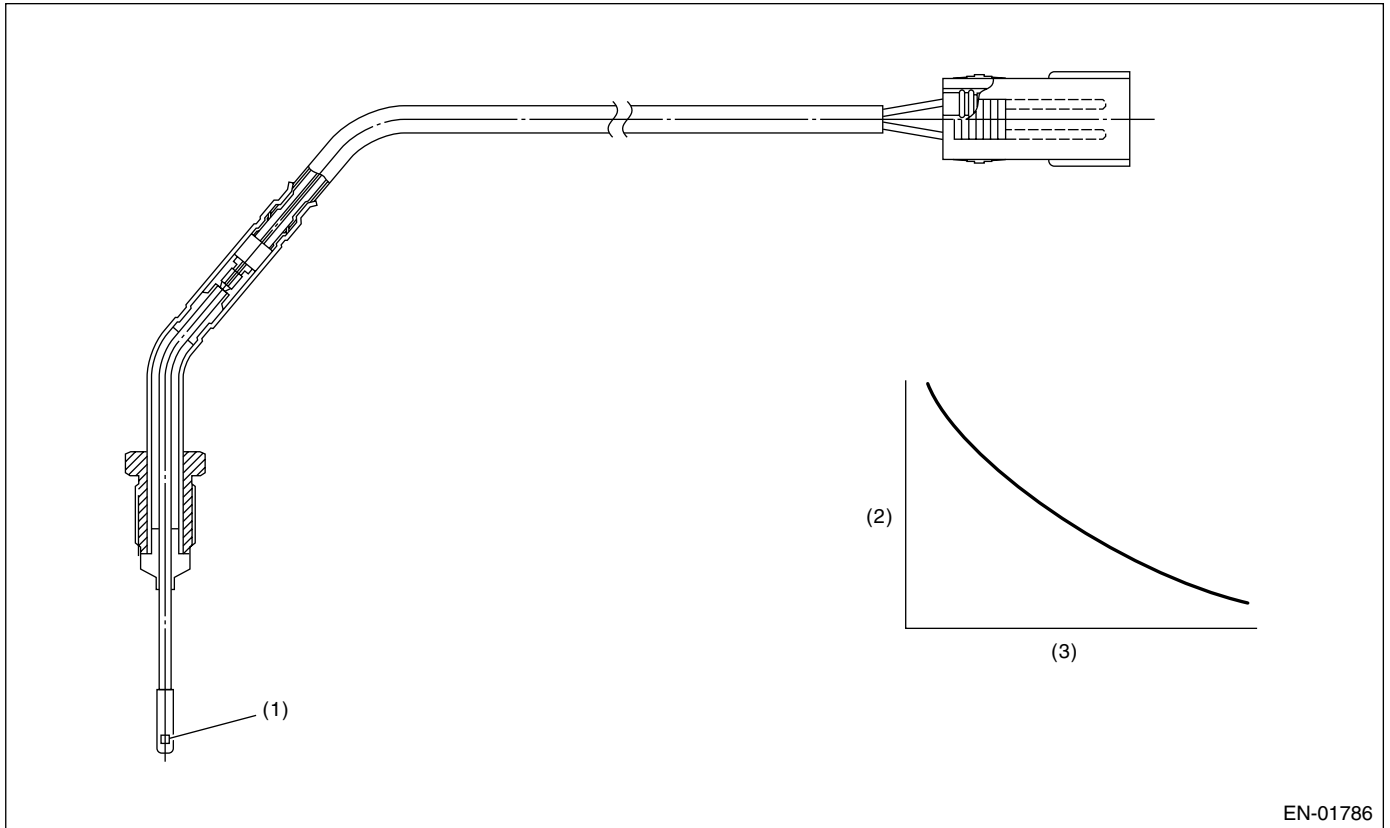

EN-01786

(1) Thermistor

(2) Resistance value (kΩ)

(3) Exhaust temperature °C (°F)

3. ENABLE CONDITION

Secondary Parameters	Enable Conditions
None	

4. GENERAL DRIVING CYCLE

Always perform the diagnosis continuously.

DIAGNOSTIC TROUBLE CODE (DTC) DETECTING CRITERIA

GENERAL DESCRIPTION

5. DIAGNOSTIC METHOD

• Abnormality Judgment

Judge NG when the cumulative time of completing the malfunction criteria below becomes more than the time needed for diagnosis (30 seconds).

• Judgment Value

Malfunction Criteria	Threshold Value
After starting engine	240 seconds or more
Engine coolant temperature	≥ 75°C (167°F)
Vehicle speed	≥ 65 km/h (40.4 MPH)
Engine speed	≥ 1800 rpm
Engine load (gn)	≥ 0.6 g (0.021 oz)/rev
Fuel cut event	Not in operation
After the recovery from fuel cut event	30 seconds or more
Sensor output voltage	≥ 4.72 V

Time Needed for Diagnosis: 30 seconds

Malfunction Indicator Light Illumination: Illuminates as soon as the malfunction occurs.

• Normality Judgment

Judge OK and clear the NG when the malfunction criteria below are completed.

• Judgment Value

Malfunction Criteria	Threshold Value
Sensor output voltage	< 4.72 V

6. DTC CLEAR CONDITION

- When the OK idling cycle was completed 40 times in a row
- When "Clear Memory" was performed

7. MALFUNCTION INDICATOR LIGHT CLEAR CONDITION

- When the OK driving cycle was completed 3 times in a row
- When "Clear Memory" was performed

8. FAIL SAFE

None

9. ECM OPERATION AT DTC SETTING

Memorize the freeze frame data. (For test mode \$02)

DIAGNOSTIC TROUBLE CODE (DTC) DETECTING CRITERIA

GENERAL DESCRIPTION

BX:DTC P0600 — CAN COMMUNICATION CIRCUIT—

1. OUTLINE OF DIAGNOSIS

Detect the malfunction of CAN communication.

It judges as NG when CAN communication becomes impossible, the CAN communication with AT becomes impossible, and the data from AT is not normal.

2. COMPONENT DISCRIPTION

CAN connects between ECU and TCU with high speed.

(Common Specification)

CAN PROTOCOL 2.0B (active)

Frame format: 11 bit ID Frame (Standard frame)

(High Speed CAN)

ISO 11898 compliance

Communication Speed: 500 kbps

3. ENABLE CONDITION

Secondary Parameters	Enable Conditions
Battery Voltages	≥ 10.9 V
Starter switch	ON
Engine	run

4. GENERAL DRIVING CYCLE

Perform the diagnosis continuously after starting the engine.

5. DIAGNOSTIC METHOD

• JUDGMENT OF MALFUNCTION

It judges as NG if any of the following conditions are judged as NG. It judges as OK if all of the following conditions are judged as OK within 1s, and the NG memory is cleared.

• Judgement Value

Malfunction Criteria	Threshold Value
Buss off flag or warning flag	Set
ID cannot be received from TCU	= 500 m/s

Time needed for Diagnosis: 1 time

Malfunction Indicator Light Illumination: Illuminates simultaneously when malfunction is detected.

6. DTC CLEAR CONDITION

When the OK driving cycle was completed 40 consecutive times.

When "Clear Memory" was performed.

7. MALFUNCTION INDICATOR LIGHT CLEAR CONDITION

- When the OK driving cycle was completed 3 consecutive times.
- When "Clear Memory" was performed.

8. FAIL-SAFE

The angle operation of accelerator position sensor demand target throttle opening calculation

9. ECM OPERATING AT DTC SETTING

Store the freeze frame data. (For test mode \$02)

DIAGNOSTIC TROUBLE CODE (DTC) DETECTING CRITERIA

GENERAL DESCRIPTION

BY:DTC P0604 — INTERNAL CONTROL MODULE RANDOM ACCESS MEMORY (RAM) ERROR —

1. OUTLINE OF DIAGNOSIS

Detect the function abnormality of the micro-computer (RAM).

Write zero to all area of RAM. After the zero initialization, judge NG when the result of addition of all values in area of RAM is not zero.

2. ENABLE CONDITION

Secondary Parameters	Enable Conditions
Ignition switch	OFF → ON

Perform the diagnosis in the initial routine.

3. GENERAL DRIVING CYCLE

Perform the diagnosis immediately after IG key SW is turned ON.

4. DIAGNOSTIC METHOD

Judge NG when the malfunction criteria below is completed, and judge OK when it is not completed.

Judgment Value

Malfunction Criteria	Threshold Value
Result of RAM data addition, after zero initialization	Except zero

Time Needed for Diagnosis: 100 milliseconds

Malfunction Indicator Light Illumination: Illuminates as soon as malfunction occurs.

5. DTC CLEAR CONDITION

- When the OK idling cycle was completed 40 times in a row
- When "Clear Memory" was performed

6. MALFUNCTION INDICATOR LIGHT CLEAR CONDITION

- When the OK driving cycle was completed 3 times in a row
- When "Clear Memory" was performed

7. FAIL SAFE

None

8. ECM OPERATION AT DTC SETTING

Memorize the freeze frame data. (For test mode \$02)

DIAGNOSTIC TROUBLE CODE (DTC) DETECTING CRITERIA

GENERAL DESCRIPTION

BZ:DTC P0605 — INTERNAL CONTROL MODULE READ ONLY MEMORY (ROM) ERROR —

1. OUTLINE OF DIAGNOSIS

Judge NG when SUM value of ROM is out of the standard value.

2. ENABLE CONDITION

Secondary Parameters	Enable Conditions
Ignition switch	ON

3. GENERAL DRIVING CYCLE

Always perform the diagnosis continuously.

4. DIAGNOSTIC METHOD

• Abnormality Judgment

Judge NG when the continuous time of completing the malfunction criteria below becomes more than 0.5 seconds.

• Judgment Value

Malfunction Criteria	Threshold Value
SUM value of ROM	Standard value

Time Needed for Diagnosis: 0.5 seconds

Malfunction Indicator Light Illumination: Illuminates as soon as malfunction occurs.

5. DTC CLEAR CONDITION

- When the OK idling cycle was completed 40 times in a row
- When “Clear Memory” was performed (Only at engine stop)

6. MALFUNCTION INDICATOR LIGHT CLEAR CONDITION

- When the OK driving cycle was completed 3 times in a row
- When “Clear Memory” was performed

7. FAIL SAFE

Stop the current to electric control throttle motor. (Fix the throttle opening angle to 6°.)

8. ECM OPERATION AT DTC SETTING

Memorize the freeze frame data. (For test mode \$02)

DIAGNOSTIC TROUBLE CODE (DTC) DETECTING CRITERIA

GENERAL DESCRIPTION

MEMO:

DIAGNOSTIC TROUBLE CODE (DTC) DETECTING CRITERIA

GENERAL DESCRIPTION

CA:DTC P0607 — CONTROL MODULE PERFORMANCE —

1. OUTLINE OF DIAGNOSIS

Judge NG when either the following is completed.

- When the read value of throttle position sensor 1 signal is mismatched between main CPU and sub CPU.
- When the read value of accelerator position sensor 1 signal is mismatched between main CPU and sub CPU.
- When the sub CPU operates abnormally.
- When the communication between main CPU and sub CPU is abnormal.
- When the input amplifier circuit of throttle position sensor 1 is abnormal.
- When the cruise control cannot be canceled correctly.
- When the signal of brake SW1 and 2 is mismatched.
- When the directed angle from main CPU is abnormal.

2. COMPONENT DESCRIPTION

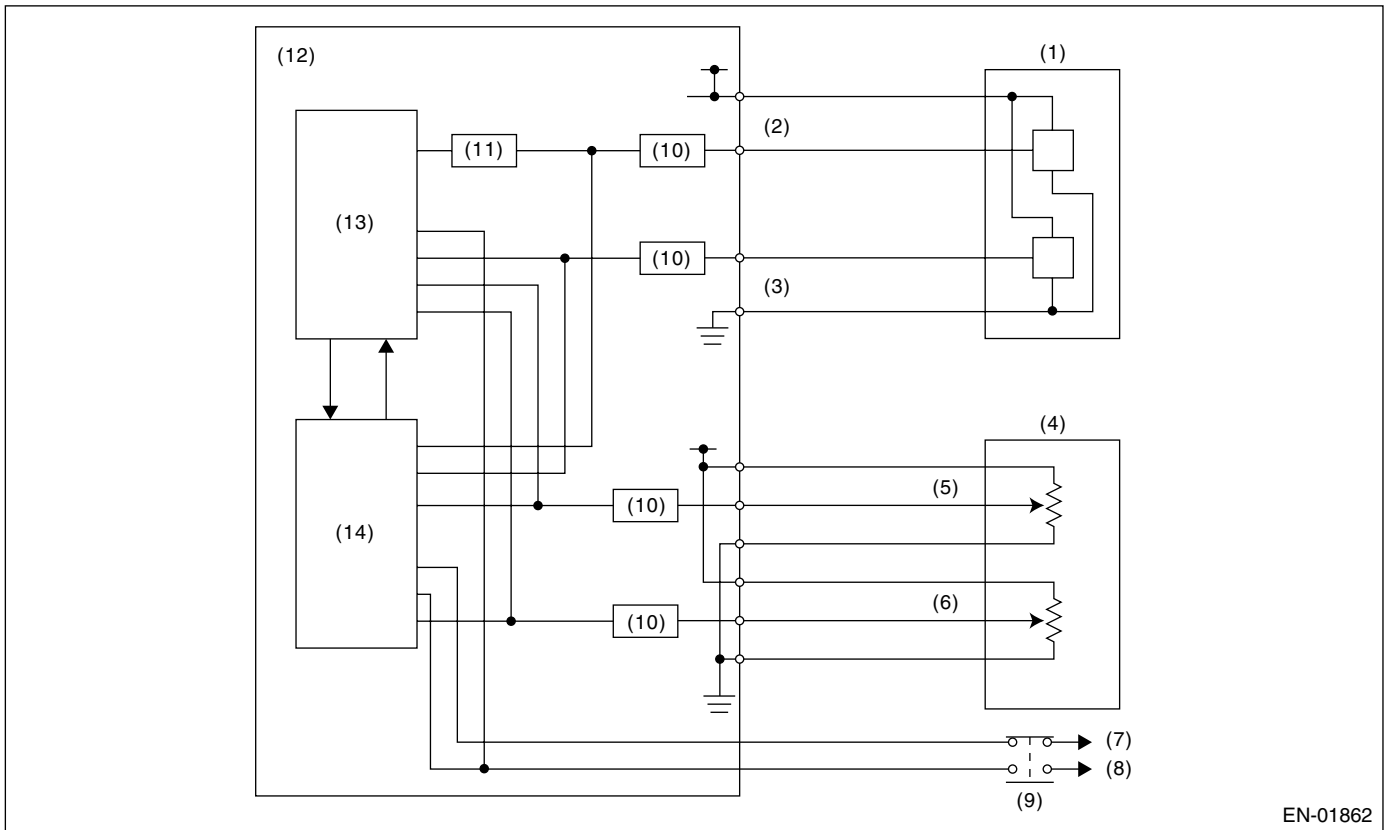

EN-01862

- | | | |
|---|---------------------------------------|----------------------------------|
| (1) Throttle position sensor | (6) Accelerator pedal position sensor | (11) Amplifier circuit |
| (2) Throttle position sensor 1 | 2 | (12) Engine control module (ECM) |
| (3) Throttle position sensor 2 | (7) Battery | (13) Sub CPU |
| (4) Accelerator pedal position sensor | (8) Stop light | (14) Main CPU |
| (5) Accelerator pedal position sensor 1 | (9) Brake switch | |
| | (10) I/F circuit | |

DIAGNOSTIC TROUBLE CODE (DTC) DETECTING CRITERIA

GENERAL DESCRIPTION

3. ENABLE CONDITION

Secondary Parameters	Enable Conditions
(1) Ignition switch	ON
(2) Ignition switch	ON
(3) None	—
(4) None	—
(5) Throttle opening angle	
(6) Brake SW (with cruise control)	ON
(7) None	—
(8) Cruise control	OFF

4. GENERAL DRIVING CYCLE

- (1) — (4): Always perform the diagnosis continuously.
(5): Always perform the diagnosis continuously on idling.
(6): Perform the diagnosis when the brake pedal is depressed.
(7): Always perform the diagnosis continuously.
(8): Always perform the diagnosis continuously when the cruise control pedal is not operating.

5. DIAGNOSTIC METHOD

Judge OK and clear NG when the malfunction criteria below are completed.

Judgment Value

Malfunction Criteria	Threshold Value
(1) Difference of CPU on reading value of throttle position sensor signal	Within 0.12 V
(2) Difference of CPU on reading value of accelerator position sensor signal	Within 0.07 V
(3) WD pulse from sub CPU	WD pulse occur
(4) Communication between CPU	Possible to communicate
(5) Difference of signal on connection of amplifier	Within $\times 4 \pm 0.6$ V
(6) Cruise control cancel signal at brake ON	Cruise control cancel signal ON
(7) Brake switch 1, 2 signal	SW 1 and 2 are matched
(8) Throttle opening angle directing value	Within the opening angle $+3.4^\circ$ which calculated from accelerator opening angle coefficient.

Time Needed for Diagnosis:

- (1) 250 milliseconds
(2) 250 milliseconds
(3) 200 milliseconds
(4) 200 milliseconds
(5) 24 milliseconds
(6) 250 milliseconds
(7) 200 milliseconds
(8) 250 milliseconds

Malfunction Indicator Light Illumination: Illuminates as soon as malfunction occurs.

6. DTC CLEAR CONDITION

- When the OK idling cycle was completed 40 times in a row
- When "Clear Memory" was performed

DIAGNOSTIC TROUBLE CODE (DTC) DETECTING CRITERIA

GENERAL DESCRIPTION

7. MALFUNCTION INDICATOR LIGHT CLEAR CONDITION

- When the OK driving cycle was completed 3 times in a row
- When "Clear Memory" was performed

8. FAIL SAFE

Stop the current to electric control throttle motor. (Fix the throttle opening angle to 6°.)

9. ECM OPERATION AT DTC SETTING

Memorize the freeze frame data. (For test mode \$02)

DIAGNOSTIC TROUBLE CODE (DTC) DETECTING CRITERIA

GENERAL DESCRIPTION

MEMO:

DIAGNOSTIC TROUBLE CODE (DTC) DETECTING CRITERIA

GENERAL DESCRIPTION

CB:DTC P0638 — THROTTLE ACTUATOR CONTROL RANGE/PERFORMANCE (BANK 1) —

1. OUTLINE OF DIAGNOSIS

Judge NG when the target opening angle and actual opening angle is mismatched or the current to motor is more than specified duty for specified time continuously.

2. COMPONENT DESCRIPTION

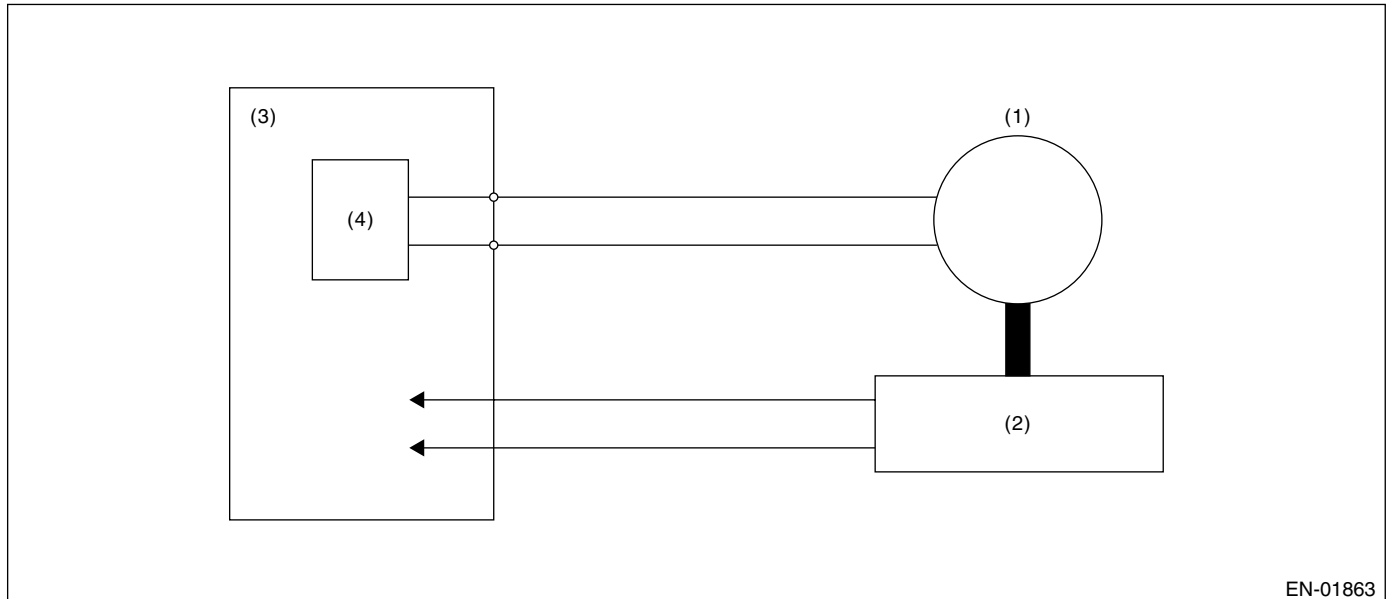

EN-01863

- (1) Motor
(2) Throttle position sensor
(3) Engine control module (ECM)
(4) Drive circuit

3. ENABLE CONDITION

Secondary Parameters	Enable Conditions
Ignition switch	ON
Normal operation of electric control throttle	ON

4. GENERAL DRIVING CYCLE

Always perform the diagnosis continuously when the electric control throttle is operating.

5. DIAGNOSTIC METHOD

Judge OK and clear NG when the malfunction criteria below are completed.

Judgment Value

Malfunction Criteria	Threshold Value
Difference between target opening angle and actual opening angle	Less than 3.5°
Output duty to drive circuit	Less than 95%

Time Needed for Diagnosis:

Target opening angle and actual opening angle: 250 milliseconds (For NG) 2000 milliseconds (For OK)
Output duty to drive circuit: 2000 milliseconds

DIAGNOSTIC TROUBLE CODE (DTC) DETECTING CRITERIA

GENERAL DESCRIPTION

Details of Judgment

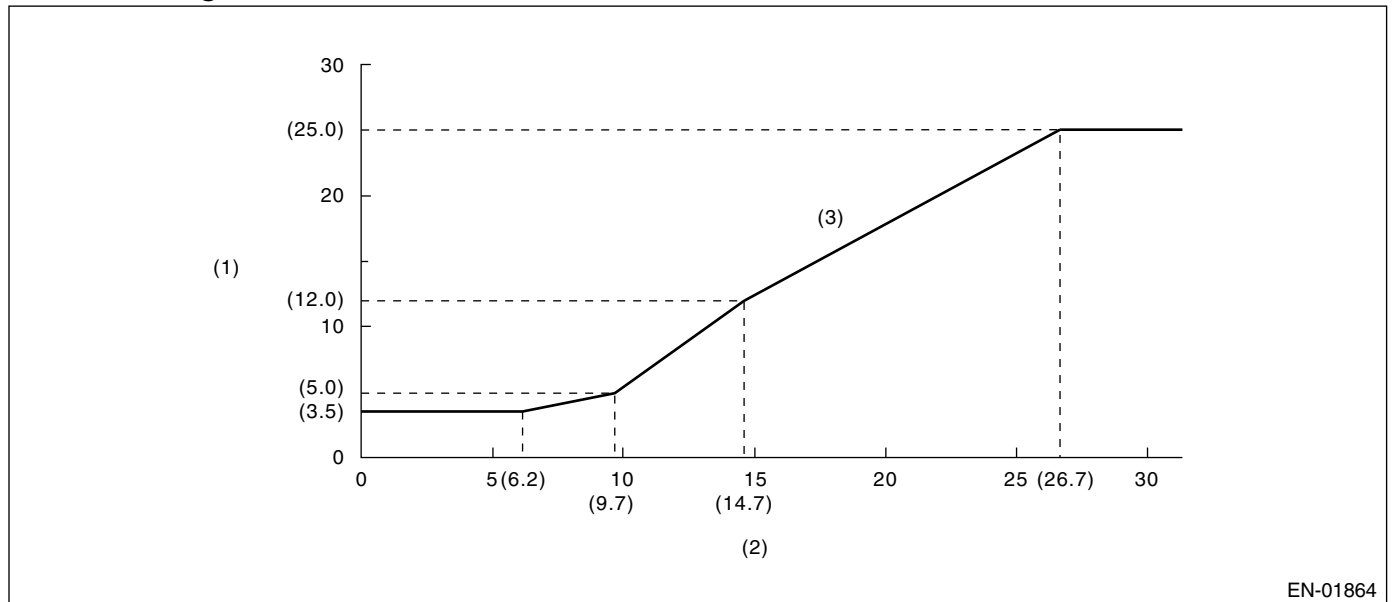

EN-01864

- (1) Difference between target opening angle and actual opening angle (°)
 (2) Target throttle opening angle (°)
 (3) NG area

Details of Judgment (Always 1000 milliseconds when the actual opening angle ≤ target opening angle)

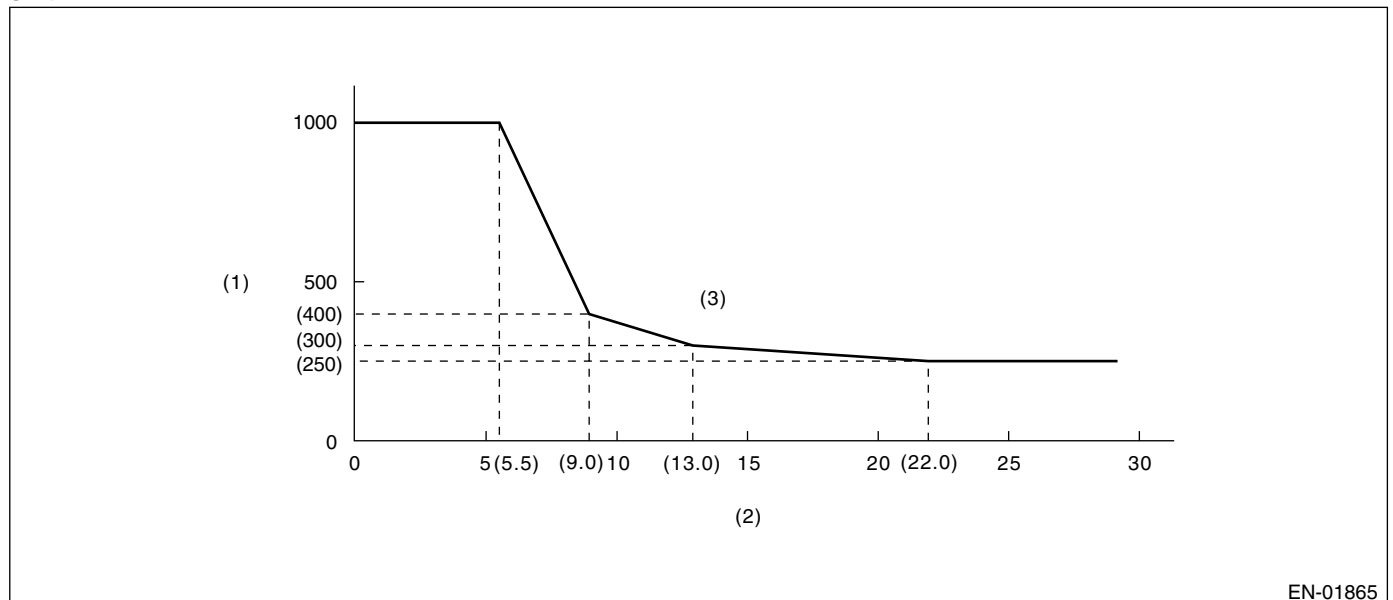

EN-01865

- (1) Judgment time (milliseconds)
 (2) Throttle position sensor 1 opening angle
 (3) NG area

Malfunction Indicator Light Illumination: Illuminates as soon as malfunction occurs.

DIAGNOSTIC TROUBLE CODE (DTC) DETECTING CRITERIA

GENERAL DESCRIPTION

6. DTC CLEAR CONDITION

- When the OK idling cycle was completed 40 times in a row
- When "Clear Memory" was performed (Only engine stopped)

7. MALFUNCTION INDICATOR LIGHT CLEAR CONDITION

- When the OK driving cycle was completed 3 times in a row
- When "Clear Memory" was performed (Only engine stopped)

8. FAIL SAFE

Stop the current to electric control throttle motor. (Fix the throttle opening angle to 6°.)

9. ECM OPERATION AT DTC SETTING

Memorize the freeze frame data. (For test mode \$02)

DIAGNOSTIC TROUBLE CODE (DTC) DETECTING CRITERIA

GENERAL DESCRIPTION

CC:DTC P0691 — COOLING FAN 1 CONTROL CIRCUIT LOW —

1. OUTLINE OF DIAGNOSIS

Detect the open or short circuit of the radiator fan circuit.

Judge NG when the ECM output level differs from the actual terminal level.

2. ENABLE CONDITION

Secondary Parameters	Enable Conditions
None	

3. GENERAL DRIVING CYCLE

Always perform the diagnosis continuously.

4. DIAGNOSTIC METHOD

• Abnormality Judgment

Judge NG when the cumulative time of completing the malfunction criteria below becomes more than 2.5 seconds.

• Judgment Value

Malfunction Criteria	Threshold Value
After starting engine	1 seconds or more
Engine speed	≥ 500 rpm
Ignition switch	ON
Battery voltage	≥ 10.9 V
Terminal voltage level when ECM transmits OFF signal	Low level

Time Needed for Diagnosis: 2.5 seconds

Malfunction Indicator Light Illumination: Illuminates when malfunction occurs in 2 continuous driving cycles.

• Normality Judgment

Judge OK and clear NG when the malfunction criteria below are completed.

• Judgment Value

Malfunction Criteria	Threshold Value
After starting engine	1 seconds or more
Engine speed	≥ 500 rpm
Ignition switch	ON
Battery voltage	≥ 10.9 V
Terminal voltage level when ECM transmits OFF signal	High level

5. DTC CLEAR CONDITION

- When the OK idling cycle was completed 40 times in a row
- When “Clear Memory” was performed

6. MALFUNCTION INDICATOR LIGHT CLEAR CONDITION

- When the OK driving cycle was completed 3 times in a row
- When “Clear Memory” was performed

7. FAIL SAFE

None

8. ECM OPERATION AT DTC SETTING

Memorize the freeze frame data. (For test mode \$02)

DIAGNOSTIC TROUBLE CODE (DTC) DETECTING CRITERIA

GENERAL DESCRIPTION

CD:DTC P0692 — COOLING FAN 1 CONTROL CIRCUIT HIGH —

1. OUTLINE OF DIAGNOSIS

Detect the open or short circuit of the radiator fan circuit.

Judge NG when the ECM output level differs from the actual terminal level.

2. ENABLE CONDITION

Secondary Parameters	Enable Conditions
None	

3. GENERAL DRIVING CYCLE

Always perform the diagnosis continuously.

4. DIAGNOSTIC METHOD

• Abnormality Judgment

Judge NG when the cumulative time of completing the malfunction criteria below becomes more than 2.5 seconds.

• Judgment Value

Malfunction Criteria	Threshold Value
After starting engine	1 seconds or more
Engine speed	≥ 500 rpm
Ignition switch	ON
Battery voltage	≥ 10.9 V
Terminal voltage level when ECM transmits ON signal	High level

Time Needed for Diagnosis: 2.5 seconds

Malfunction Indicator Light Illumination: Illuminates when malfunction occurs in 2 continuous driving cycles.

• Normality Judgment

Judge OK and clear NG when the malfunction criteria below are completed.

• Judgment Value

Malfunction Criteria	Threshold Value
After starting engine	1 seconds or more
Engine speed	≥ 500 rpm
Ignition switch	ON
Battery voltage	≥ 10.9 V
Terminal voltage level when ECM transmits ON signal	Low level

5. DTC CLEAR CONDITION

- When the OK idling cycle was completed 40 times in a row
- When "Clear Memory" was performed

6. MALFUNCTION INDICATOR LIGHT CLEAR CONDITION

- When the OK driving cycle was completed 3 times in a row
- When "Clear Memory" was performed

7. FAIL SAFE

None

8. ECM OPERATION AT DTC SETTING

Memorize the freeze frame data. (For test mode \$02)

DIAGNOSTIC TROUBLE CODE (DTC) DETECTING CRITERIA

GENERAL DESCRIPTION

CE:DTC P0700 — AT MIL LIGHT UP REQUEST —

1. OUTLINE OF DIAGNOSIS

AT C/U performs CAN communication. It judges as NG if malfunction is detected.

2. ENABLE CONDITION

Secondary Parameters	Enable Conditions
Battery Voltage	≥ 10.9 V

3. GENERAL DRIVING CYCLE

Always perform diagnosis continuously.

4. DIAGNOSTIC METHOD

It judges as NG if the following condition malfunctions more than the predetermined time (0.5s). It judges as OK if the following condition does not malfunction, and the NG memory is cleared.

Judgement Value

Malfunction Criteria	Threshold Value
MIL light up request from TCU	set

Time needed for diagnosis: 500 m/seconds

Malfunction Indicator Light Illumination: Illuminates simultaneously when malfunction is detected.

5. DTC CLEAR CONDITION

- When the OK driving cycle was completed 40 consecutive times.
- When “Clear Memory” was performed.

6. MALFUNCTION INDICATOR LIGHT CLEAR CONDITION

- When the OK driving cycle was completed 3 consecutive times.
- When “Clear Memory” was performed.

7. FAIL-SAFE

None

8. ECU OPERATING AT DTC SETTING

Store the freeze frame data. (For test mode \$02)

DIAGNOSTIC TROUBLE CODE (DTC) DETECTING CRITERIA

GENERAL DESCRIPTION

CF:DTC P0851 — NEUTRAL SWITCH INPUT CIRCUIT LOW (AT model) —

1. OUTLINE OF DIAGNOSIS

Detect the open or short circuit of the neutral SW.

Judge NG when the ECM neutral terminal input differs from the reception data from TCM.

2. ENABLE CONDITION

Secondary Parameters	Enable Conditions
Ignition switch	ON
Battery voltage	≥ 10.9 V
After starting engine	2 seconds or more
Starter switch	OFF

3. GENERAL DRIVING CYCLE

Perform the diagnosis continuously in 2 seconds or more after starting the engine.

4. DIAGNOSTIC METHOD

Judge NG when the continuous time of completing the malfunction criteria below becomes more than 6.5 seconds. Judge OK and clear NG when the malfunction criteria below are not completed.

Judgment Value

Malfunction Criteria	Threshold Value
Neutral switch signal when park/neutral = "ON" & any other switches = "OFF" on AT	OFF

Time Needed for Diagnosis: 6.5 seconds

Malfunction Indicator Light Illumination: Illuminates when malfunction occurs in 2 continuous driving cycles.

5. DTC CLEAR CONDITION

- When the OK idling cycle was completed 40 times in a row
- When "Clear Memory" was performed

6. MALFUNCTION INDICATOR LIGHT CLEAR CONDITION

- When the OK driving cycle was completed 3 times in a row
- When "Clear Memory" was performed

7. FAIL SAFE

None

8. ECM OPERATION AT DTC SETTING

Memorize the freeze frame data. (For test mode \$02)

DIAGNOSTIC TROUBLE CODE (DTC) DETECTING CRITERIA

GENERAL DESCRIPTION

CG:DTC P0851 — NEUTRAL SWITCH INPUT CIRCUIT LOW (MT model) —

1. OUTLINE OF DIAGNOSIS

Judge the open or short circuit of the neutral SW.

Judge NG when there is no change in the neutral SW even if the driving shift was applied. (There is neutral SW ON/OFF inversion from the vehicle speed and engine speed.)

2. ENABLE CONDITION

Secondary Parameters	Enable Conditions
Ignition switch	ON
Battery voltage	≥ 10.9 V
After starting engine	2 seconds or more
Starter switch	OFF

3. GENERAL DRIVING CYCLE

Perform the diagnosis continuously in 2 seconds or more after starting the engine.

4. DIAGNOSTIC METHOD

Judge NG when the malfunction criteria below are completed 3 time or more after the neutral SW change. And clear NG if there is change in the neutral SW.

Judgment Value

Malfunction Criteria	Threshold Value
Neutral switch signal (while changing from a to b below)	OFF continues
Driving condition change	a) to b)
a) Vehicle speed = 0 km/h (0 MPH) & engine speed 600 — 900 rpm	
b) Vehicle speed ≥ 64 km/h (40 MPH) & engine speed 1600 — 2550 rpm	

Time Needed for Diagnosis: 3 monitoring

Malfunction Indicator Light Illumination: Illuminates when malfunction occurs in 2 continuous driving cycles.

5. DTC CLEAR CONDITION

- When the OK idling cycle was completed 40 times in a row
- When “Clear Memory” was performed

6. MALFUNCTION INDICATOR LIGHT CLEAR CONDITION

- When the OK driving cycle was completed 3 times in a row
- When “Clear Memory” was performed

7. FAIL SAFE

Cruise control command: Not allowed to command cruise control

8. ECM OPERATION AT DTC SETTING

Memorize the freeze frame data. (For test mode \$02)

DIAGNOSTIC TROUBLE CODE (DTC) DETECTING CRITERIA

GENERAL DESCRIPTION

CH:DTC P0852 — NEUTRAL SWITCH INPUT CIRCUIT HIGH (AT model) —

1. OUTLINE OF DIAGNOSIS

Detect the open or short circuit of the neutral SW.

Judge NG when the ECM neutral terminal input differs from the reception data from TCM.

2. ENABLE CONDITION

Secondary Parameters	Enable Conditions
Ignition switch	ON
Battery voltage	≥ 10.9 V
After starting engine	2 seconds or more
Starter switch	OFF

3. GENERAL DRIVING CYCLE

Perform the diagnosis continuously in 2 seconds or more after starting the engine.

4. DIAGNOSTIC METHOD

Judge NG when the continuous time until completing the malfunction criteria below becomes more than 6.5 seconds. Judge OK and clear NG when the malfunction criteria below are not completed.

Judgment Value

Malfunction Criteria	Threshold Value
Neutral switch signal when park/neutral = "OFF" & any other switches = "ON" on AT	ON

Time Needed for Diagnosis: 6.5 seconds

Malfunction Indicator Light Illumination: Illuminates when malfunction occurs in 2 continuous driving cycles.

5. DTC CLEAR CONDITION

- When the OK idling cycle was completed 40 times in a row
- When "Clear Memory" was performed

6. MALFUNCTION INDICATOR LIGHT CLEAR CONDITION

- When the OK driving cycle was completed 3 times in a row
- When "Clear Memory" was performed

7. FAIL SAFE

None

8. ECM OPERATION AT DTC SETTING

Memorize the freeze frame data. (For test mode \$02)

DIAGNOSTIC TROUBLE CODE (DTC) DETECTING CRITERIA

GENERAL DESCRIPTION

CI: DTC P0852 — NEUTRAL SWITCH INPUT CIRCUIT HIGH (MT model) —

1. OUTLINE OF DIAGNOSIS

Judge the open or short circuit of the neutral SW.

Judge NG when there is no change in the neutral SW even if the driving shift was applied. (There is neutral SW ON/OFF inversion from the vehicle speed and engine speed.)

2. ENABLE CONDITION

Secondary Parameters	Enable Conditions
Ignition switch	ON
Battery voltage	≥ 10.9 V
After starting engine	2 seconds or more
Starter switch	OFF

3. GENERAL DRIVING CYCLE

Perform the diagnosis continuously in 2 seconds or more after starting the engine.

4. DIAGNOSTIC METHOD

Judge NG when the malfunction criteria below are completed 3 time or more after the neutral SW change. And clear NG if there is change in the neutral SW.

Judgment Value

Malfunction Criteria	Threshold Value
Neutral switch signal (while changing from a to b below)	ON continues
Driving condition change	a) to b)
a) Vehicle speed = 0 km/h (0 MPH) & engine speed 600 — 900 rpm	
b) Vehicle speed ≥ 64 km/h (40 MPH) & engine speed 1600 — 2550 rpm	

Time Needed for Diagnosis: 3 monitoring

Malfunction Indicator Light Illumination: Illuminates when malfunction occurs in 2 continuous driving cycles.

5. DTC CLEAR CONDITION

- When the OK idling cycle was completed 40 times in a row
- When "Clear Memory" was performed

6. MALFUNCTION INDICATOR LIGHT CLEAR CONDITION

- When the OK driving cycle was completed 3 times in a row
- When "Clear Memory" was performed

7. FAIL SAFE

None

8. ECM OPERATION AT DTC SETTING

Memorize the freeze frame data. (For test mode \$02)

DIAGNOSTIC TROUBLE CODE (DTC) DETECTING CRITERIA

GENERAL DESCRIPTION

CJ:DTC P1086 — TUMBLE GENERATED VALVE POSITION SENSOR 2 CIRCUIT LOW —

1. OUTLINE OF DIAGNOSIS

Detect open or short circuit of tumble generated valve position sensor.
Judge NG when the value is out of standard range.

2. COMPONENT DESCRIPTION

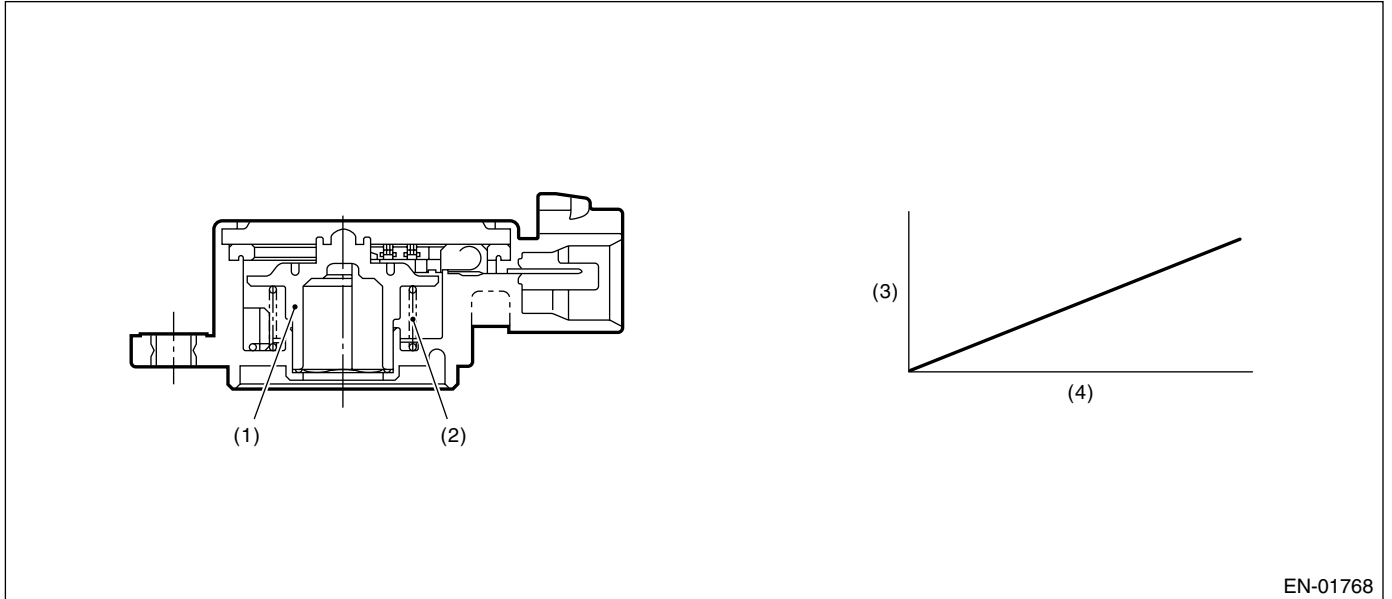

EN-01768

(1) Rotor

(2) Return spring

(3) Voltage (V)

(4) Tumble generated valve angle (°)

3. ENABLE CONDITION

Secondary Parameters	Enable Conditions
None	

4. GENERAL DRIVING CYCLE

Always perform diagnosis.

5. DIAGNOSTIC METHOD

Judge NG when the continuous time of completing the malfunction criteria below becomes more than the time needed for diagnosis (0.5 seconds). Judge OK and clear NG when the malfunction criteria below are not completed.

Judgment Value

Malfunction Criteria	Threshold Value
Output voltage	< 0.167 V

Time Needed for Diagnosis: 0.5 seconds

Malfunction Indicator Light Illumination: Illuminates as soon as malfunction occurs.

6. DTC CLEAR CONDITION

- When the OK idling cycle was completed 40 times in a row
- When "Clear Memory" was performed

DIAGNOSTIC TROUBLE CODE (DTC) DETECTING CRITERIA

GENERAL DESCRIPTION

7. MALFUNCTION INDICATOR LIGHT CLEAR CONDITION

- When the OK driving cycle was completed 3 times in a row
- When "Clear Memory" was performed

8. FAIL SAFE

Tumble generated valve position

- Learning of tumble generated valve position fully closed and date renewed to close side.
- Learning of tumble generated valve position fully opened and date renewed to open side.

9. ECM OPERATION AT DTC SETTING

Memorize the freeze frame data. (For test mode \$02)

DIAGNOSTIC TROUBLE CODE (DTC) DETECTING CRITERIA

GENERAL DESCRIPTION

CK:DTC P1087 — TUMBLE GENERATED VALVE POSITION SENSOR 2 CIRCUIT HIGH —

1. OUTLINE OF DIAGNOSIS

Detect open or short circuit of tumble generated valve position sensor.
Judge NG when the value is out of standard range.

2. COMPONENT DESCRIPTION

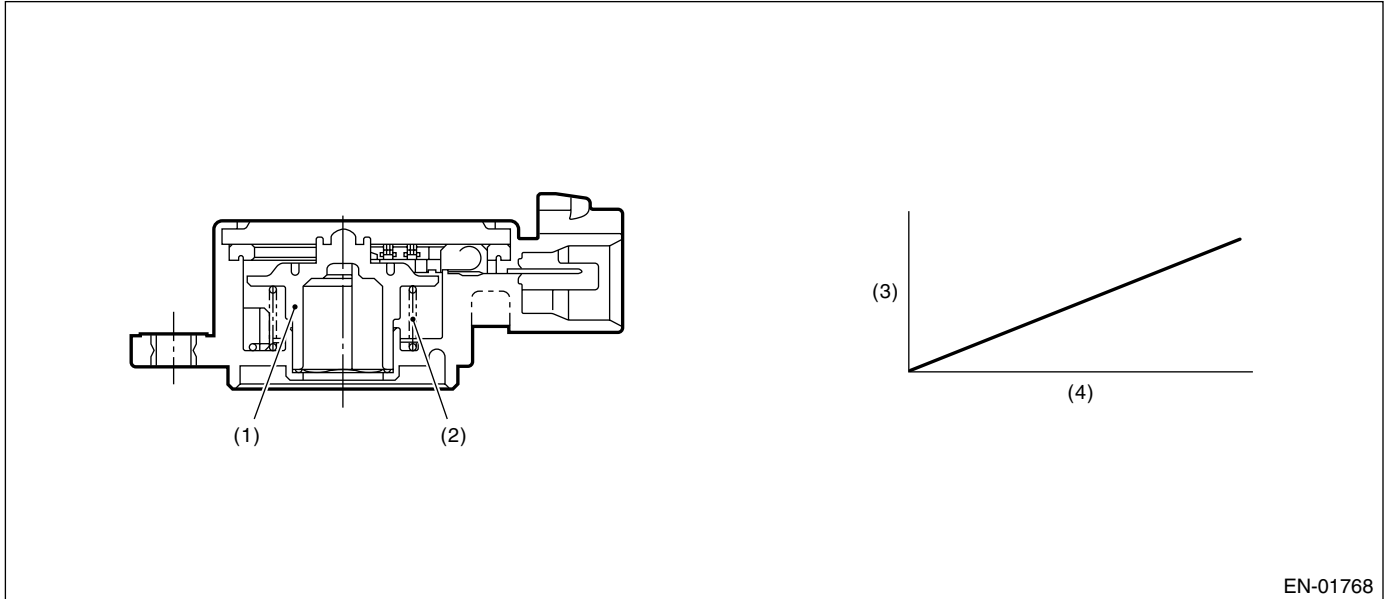

EN-01768

(1) Rotor

(2) Return spring

(3) Voltage (V)

(4) Tumble generated valve angle (°)

3. ENABLE CONDITION

Secondary Parameters	Enable Conditions
None	

4. GENERAL DRIVING CYCLE

Always perform diagnosis.

5. DIAGNOSTIC METHOD

Judge NG when the continuous time of completing the malfunction criteria below becomes more than the time needed for diagnosis (0.5 seconds). Judge OK and clear NG when the malfunction criteria below are not completed.

Judgment Value

Malfunction Criteria	Threshold Value
Output voltage	≥ 4.843 V

Time Needed for Diagnosis: 0.5 seconds

Malfunction Indicator Light Illumination: Illuminates as soon as malfunction occurs.

6. DTC CLEAR CONDITION

- When the OK idling cycle was completed 40 times in a row
- When "Clear Memory" was performed

DIAGNOSTIC TROUBLE CODE (DTC) DETECTING CRITERIA

GENERAL DESCRIPTION

7. MALFUNCTION INDICATOR LIGHT CLEAR CONDITION

- When the OK driving cycle was completed 3 times in a row
- When "Clear Memory" was performed

8. FAIL SAFE

Tumble generated valve position

- Learning of tumble generated valve position fully closed and date renewed to close side.
- Learning of tumble generated valve position fully opened and date renewed to open side.

9. ECM OPERATION AT DTC SETTING

Memorize the freeze frame data. (For test mode \$02)

DIAGNOSTIC TROUBLE CODE (DTC) DETECTING CRITERIA

GENERAL DESCRIPTION

CL:DTC P1088 — TUMBLE GENERATED VALVE POSITION SENSOR 1 CIRCUIT LOW —

1. OUTLINE OF DIAGNOSIS

Detect open or short circuit of tumble generated valve position sensor.
Judge NG when the value is out of standard range.

2. COMPONENT DESCRIPTION

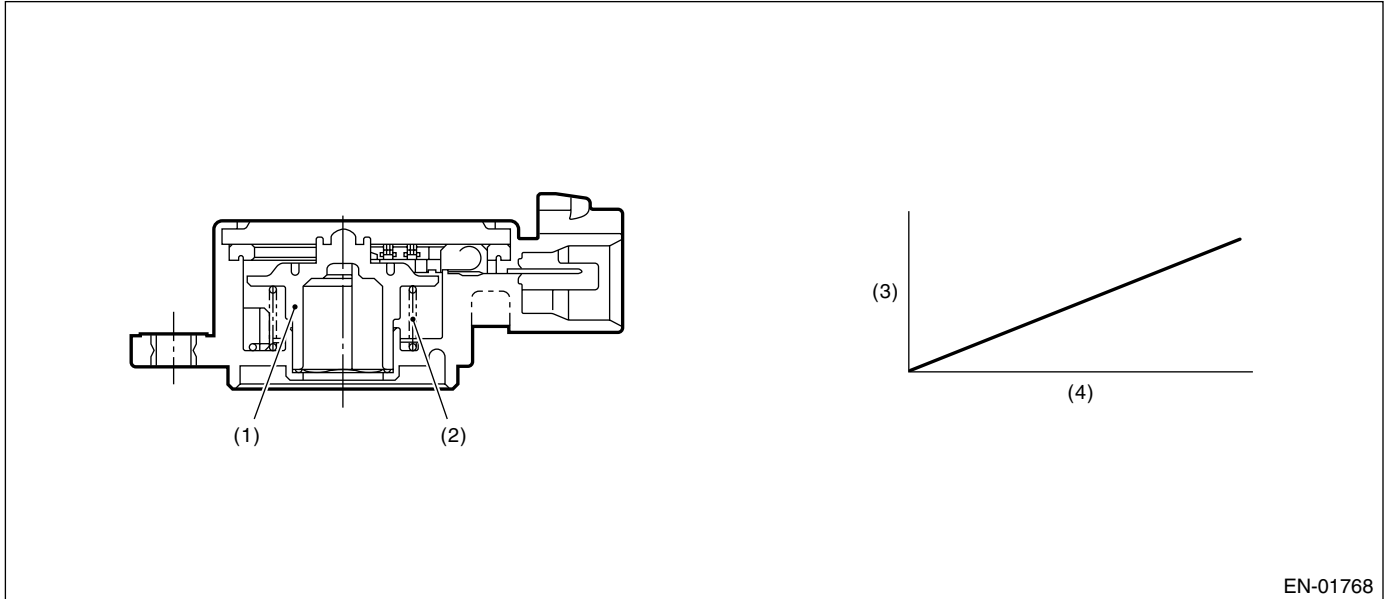

EN-01768

(1) Rotor

(2) Return spring

(3) Voltage (V)

(4) Tumble generated valve angle (°)

3. ENABLE CONDITION

Secondary Parameters	Enable Conditions
None	

4. GENERAL DRIVING CYCLE

Always perform diagnosis.

5. DIAGNOSTIC METHOD

Judge NG when the continuous time of completing the malfunction criteria below becomes more than the time needed for diagnosis (0.5 seconds). Judge OK and clear NG when the malfunction criteria below are not completed.

Judgment Value

Malfunction Criteria	Threshold Value
Output voltage	< 0.167 V

Time Needed for Diagnosis: 0.5 seconds

Malfunction Indicator Light Illumination: Illuminates as soon as malfunction occurs.

6. DTC CLEAR CONDITION

- When the OK idling cycle was completed 40 times in a row
- When "Clear Memory" was performed

DIAGNOSTIC TROUBLE CODE (DTC) DETECTING CRITERIA

GENERAL DESCRIPTION

7. MALFUNCTION INDICATOR LIGHT CLEAR CONDITION

- When the OK driving cycle was completed 3 times in a row
- When "Clear Memory" was performed

8. FAIL SAFE

Tumble generated valve position

- Learning of tumble generated valve position fully closed and date renewed to close side.
- Learning of tumble generated valve position fully opened and date renewed to open side.

9. ECM OPERATION AT DTC SETTING

Memorize the freeze frame data. (For test mode \$02)

DIAGNOSTIC TROUBLE CODE (DTC) DETECTING CRITERIA

GENERAL DESCRIPTION

CM:DTC P1089 — TUMBLE GENERATED VALVE POSITION SENSOR 1 CIRCUIT HIGH —

1. OUTLINE OF DIAGNOSIS

Detect open or short circuit of tumble generated valve position sensor.
Judge NG when the value is out of standard range.

2. COMPONENT DESCRIPTION

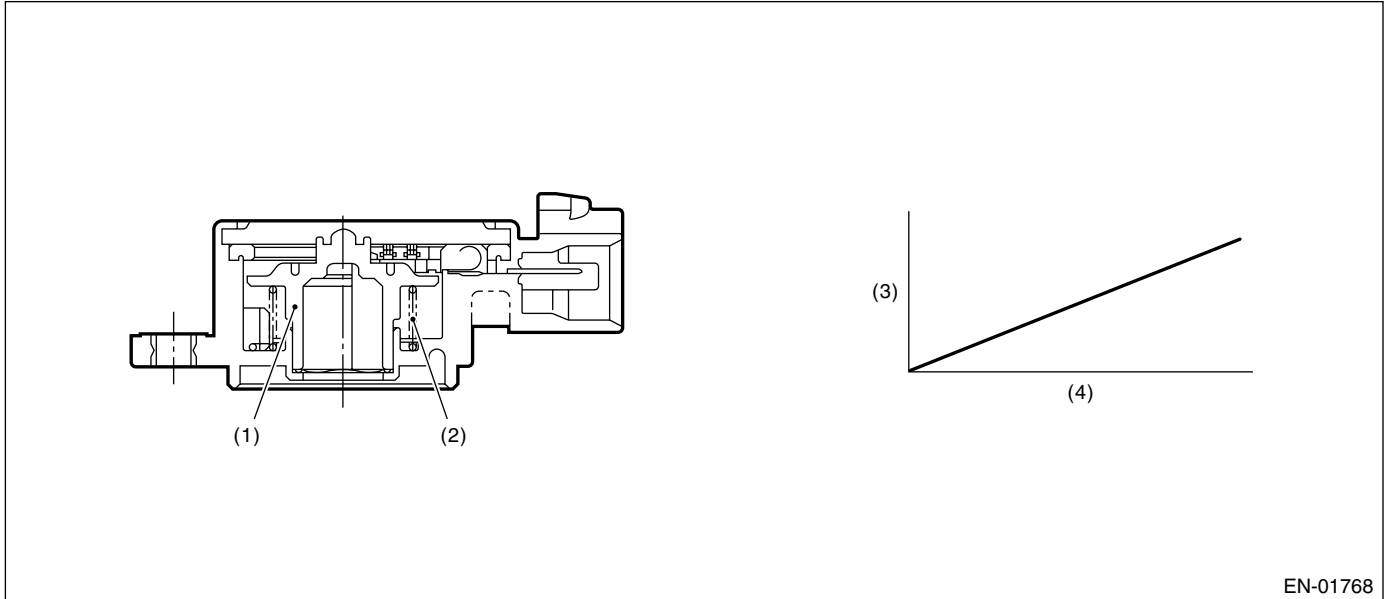

EN-01768

(1) Rotor

(2) Return spring

(3) Voltage (V)

(4) Tumble generated valve angle (°)

3. ENABLE CONDITION

Secondary Parameters	Enable Conditions
None	

4. GENERAL DRIVING CYCLE

Always perform diagnosis.

5. DIAGNOSTIC METHOD

Judge NG when the continuous time of completing the malfunction criteria below becomes more than the time needed for diagnosis (0.5 seconds). Judge OK and clear NG when the malfunction criteria below are not completed.

Judgment Value

Malfunction Criteria	Threshold Value
Output voltage	≥ 4.843 V

Time Needed for Diagnosis: 0.5 seconds

Malfunction Indicator Light Illumination: Illuminates as soon as malfunction occurs.

6. DTC CLEAR CONDITION

- When the OK idling cycle was completed 40 times in a row
- When "Clear Memory" was performed

DIAGNOSTIC TROUBLE CODE (DTC) DETECTING CRITERIA

GENERAL DESCRIPTION

7. MALFUNCTION INDICATOR LIGHT CLEAR CONDITION

- When the OK driving cycle was completed 3 times in a row
- When "Clear Memory" was performed

8. FAIL SAFE

Tumble generated valve position

- Learning of tumble generated valve position fully closed and date renewed to close side.
- Learning of tumble generated valve position fully opened and date renewed to open side.

9. ECM OPERATION AT DTC SETTING

Memorize the freeze frame data. (For test mode \$02)

DIAGNOSTIC TROUBLE CODE (DTC) DETECTING CRITERIA

GENERAL DESCRIPTION

CN:DTC P1090 — TUMBLE GENERATED VALVE SYSTEM 1 (VALVE OPEN) —

1. OUTLINE OF DIAGNOSIS

Detect the malfunction of tumble generated valve motor function.

Judge open fixing malfunction when the opening degree is large even after finishing the tumble generated valve close driving.

2. ENABLE CONDITION

Secondary Parameters	Enable Conditions
Battery voltage	≥ 10.9 V
Engine coolant temperature	$\geq 0^{\circ}\text{C}$ (32°F)
Ambient temperature	$\geq 0^{\circ}\text{C}$ (32°F)

3. GENERAL DRIVING CYCLE

Always perform the diagnosis continuously.

4. DIAGNOSTIC METHOD

• Abnormality Judgment

Judge NG when the continuous time of completing the malfunction criteria below becomes more than 3 seconds.

• Judgment Value

Malfunction Criteria	Threshold Value
Tumble generated valve angle	$\geq 67.4^{\circ}$
Tumble generated valve "close" signal output	2.2 seconds or more

Time Needed for Diagnosis: 3 seconds

Malfunction Indicator Light Illumination: Illuminates as soon as malfunction occurs.

• Normality Judgment

Judge OK and clear the NG when the malfunction criteria below are completed.

• Judgment Value

Malfunction Criteria	Threshold Value
Tumble generated valve angle	$< 67.4^{\circ}$
Tumble generated valve "close" signal output	2.2 seconds or more

5. DTC CLEAR CONDITION

- When the OK idling cycle was completed 40 times in a row
- When "Clear Memory" was performed

6. MALFUNCTION INDICATOR LIGHT CLEAR CONDITION

- When the OK driving cycle was completed 3 times in a row
- When "Clear Memory" was performed

7. FAIL SAFE

Tumble generated valve opening

- For tumble generated valve all closing points learning, not allowed to update to the closing side.
- For tumble generated valve all opening points learning, not allowed to update to the opening side.

Tumble generated valve control

- Output the open signal.

8. ECM OPERATION AT DTC SETTING

Memorize the freeze frame data. (For test mode \$02)

DIAGNOSTIC TROUBLE CODE (DTC) DETECTING CRITERIA

GENERAL DESCRIPTION

CO:DTC P1091 — TUMBLE GENERATED VALVE SYSTEM 1 (VALVE CLOSE) —

1. OUTLINE OF DIAGNOSIS

Detect the malfunction of tumble generated valve motor function.

Judge close fixing malfunction when the opening degree is small even after finishing the tumble generated valve open driving.

2. ENABLE CONDITION

Secondary Parameters	Enable Conditions
Battery voltage	≥ 10.9 V
Engine coolant temperature	$\geq 0^{\circ}\text{C}$ (32°F)
Ambient temperature	$\geq 0^{\circ}\text{C}$ (32°F)

3. GENERAL DRIVING CYCLE

Always perform the diagnosis continuously.

4. DIAGNOSTIC METHOD

• Abnormality Judgment

Judge NG when the continuous time of completing the malfunction criteria below becomes more than 3 seconds.

• Judgment Value

Malfunction Criteria	Threshold Value
Tumble generated valve angle	$< 67.4^{\circ}$
Tumble generated valve "open" signal output	2.2 seconds or more

Time Needed for Diagnosis: 3 seconds

Malfunction Indicator Light Illumination: Illuminates as soon as malfunction occurs.

• Normality Judgment

Judge OK and clear the NG when the malfunction criteria below are completed.

• Judgment Value

Malfunction Criteria	Threshold Value
Tumble generated valve angle	$\geq 67.4^{\circ}$
Tumble generated valve "open" signal output	2.2 seconds or more

5. DTC CLEAR CONDITION

- When the OK idling cycle was completed 40 times in a row
- When "Clear Memory" was performed

6. MALFUNCTION INDICATOR LIGHT CLEAR CONDITION

- When the OK driving cycle was completed 3 times in a row
- When "Clear Memory" was performed

7. FAIL SAFE

Tumble generated valve opening

- For tumble generated valve all closing points learning, not allowed to update to the closing side.
- For tumble generated valve all opening points learning, not allowed to update to the opening side.

Tumble generated valve control

- Output the close signal.

8. ECM OPERATION AT DTC SETTING

Memorize the freeze frame data. (For test mode \$02)

DIAGNOSTIC TROUBLE CODE (DTC) DETECTING CRITERIA

GENERAL DESCRIPTION

CP:DTC P1092 — TUMBLE GENERATED VALVE SYSTEM 2 (VALVE OPEN) —

1. OUTLINE OF DIAGNOSIS

Detect the malfunction of tumble generated valve motor function.

Judge open fixing malfunction when the opening degree is large even after finishing the tumble generated valve closing driving.

2. ENABLE CONDITION

Secondary Parameters	Enable Conditions
Battery voltage	≥ 10.9 V
Engine coolant temperature	$\geq 0^{\circ}\text{C}$ (32°F)
Ambient temperature	$\geq 0^{\circ}\text{C}$ (32°F)

3. GENERAL DRIVING CYCLE

Always perform the diagnosis continuously.

4. DIAGNOSTIC METHOD

• Abnormality Judgment

Judge NG when the continuous time of completing the malfunction criteria below becomes more than 3 seconds.

• Judgment Value

Malfunction Criteria	Threshold Value
Tumble generated valve angle	$\geq 67.4^{\circ}$
Tumble generated valve "close" signal output	2.2 seconds or more

Time Needed for Diagnosis: 3 seconds

Malfunction Indicator Light Illumination: Illuminates as soon as malfunction occurs.

• Normality Judgment

Judge OK and clear the NG when the malfunction criteria below are completed.

• Judgment Value

Malfunction Criteria	Threshold Value
Tumble generated valve angle	$< 67.4^{\circ}$
Tumble generated valve "close" signal output	2.2 seconds or more

5. DTC CLEAR CONDITION

- When the OK idling cycle was completed 40 times in a row
- When "Clear Memory" was performed

6. MALFUNCTION INDICATOR LIGHT CLEAR CONDITION

- When the OK driving cycle was completed 3 times in a row
- When "Clear Memory" was performed

7. FAIL SAFE

Tumble generated valve opening

- For tumble generated valve all closing points learning, not allowed to update to the closing side.
- For tumble generated valve all opening points learning, not allowed to update to the opening side.

Tumble generated valve control

- Output the open signal.

8. ECM OPERATION AT DTC SETTING

Memorize the freeze frame data. (For test mode \$02)

DIAGNOSTIC TROUBLE CODE (DTC) DETECTING CRITERIA

GENERAL DESCRIPTION

CQ:DTC P1093 — TUMBLE GENERATED VALVE SYSTEM 2 (VALVE CLOSE) —

1. OUTLINE OF DIAGNOSIS

Detect the malfunction of tumble generated valve motor function.

Judge close fixing malfunction when the opening degree is small even after finishing the tumble generated valve open driving.

2. ENABLE CONDITION

Secondary Parameters	Enable Conditions
Battery voltage	≥ 10.9 V
Engine coolant temperature	$\geq 0^{\circ}\text{C}$ (32°F)
Ambient temperature	$\geq 0^{\circ}\text{C}$ (32°F)

3. GENERAL DRIVING CYCLE

Always perform the diagnosis continuously.

4. DIAGNOSTIC METHOD

• Abnormality Judgment

Judge NG when the continuous time of completing the malfunction criteria below becomes more than 3 seconds.

• Judgment Value

Malfunction Criteria	Threshold Value
Tumble generated valve angle	$< 67.4^{\circ}$
Tumble generated valve "open" signal output	2.2 seconds or more

Time Needed for Diagnosis: 3 seconds

Malfunction Indicator Light Illumination: Illuminates as soon as malfunction occurs.

• Normality Judgment

Judge OK and clear the NG when the malfunction criteria below are completed.

• Judgment Value

Malfunction Criteria	Threshold Value
Tumble generated valve angle	$\geq 67.4^{\circ}$
Tumble generated valve "open" signal output	2.2 seconds or more

5. DTC CLEAR CONDITION

- When the OK idling cycle was completed 40 times in a row
- When "Clear Memory" was performed

6. MALFUNCTION INDICATOR LIGHT CLEAR CONDITION

- When the OK driving cycle was completed 3 times in a row
- When "Clear Memory" was performed

7. FAIL SAFE

Tumble generated valve opening

- For tumble generated valve all closing points learning, not allowed to update to the closing side.
- For tumble generated valve all opening points learning, not allowed to update to the opening side.

Tumble generated valve control

- Output the close signal.

8. ECM OPERATION AT DTC SETTING

Memorize the freeze frame data. (For test mode \$02)

DIAGNOSTIC TROUBLE CODE (DTC) DETECTING CRITERIA

GENERAL DESCRIPTION

CR:DTC P1094 — TUMBLE GENERATED VALVE SIGNAL 1 CIRCUIT MALFUNCTION (OPEN) —

1. OUTLINE OF DIAGNOSIS

Detect the open or short circuit of tumble generated valve motor.

Judge NG when the open signal is sent from IC after tumble generated valve driving IC diagnosis.

2. COMPONENT DESCRIPTION

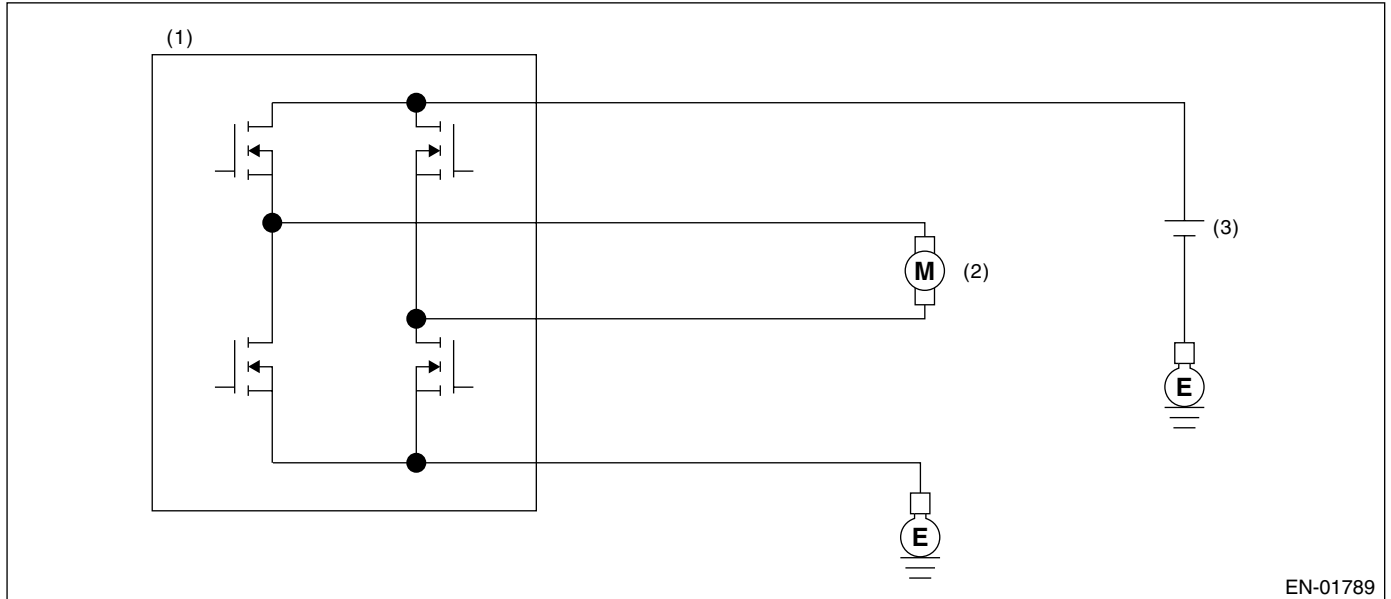

EN-01789

(1) Engine control module (ECM)

(2) Tumble generated valve

(3) Battery

3. ENABLE CONDITION

Secondary Parameters	Enable Conditions
Battery voltage	≥ 10.9 V
ECM output signal	before set ON → OFF
Tumble generated valve ON signal output	20 milliseconds or more

4. GENERAL DRIVING CYCLE

Always perform the diagnosis continuously.

5. DIAGNOSTIC METHOD

At the main IC, check the sent signal at each timing which occurs just before the tumble generated valve output is set to ON and OFF, and judge open NG when the open NG signal is sent during 10 seconds in a row. Judge OK and clear the NG when the OK signal is sent.

Judgment Value

Malfunction Criteria	Threshold Value
Open NG signal input	High
Overcurrent NG signal input	Low

Time Needed for Diagnosis: 10 seconds

Malfunction Indicator Light Illumination: Illuminates as soon as malfunction occurs.

6. DTC CLEAR CONDITION

- When the OK idling cycle was completed 40 times in a row
- When “Clear Memory” was performed

DIAGNOSTIC TROUBLE CODE (DTC) DETECTING CRITERIA

GENERAL DESCRIPTION

7. MALFUNCTION INDICATOR LIGHT CLEAR CONDITION

- When the OK driving cycle was completed 3 times in a row
- When "Clear Memory" was performed

8. FAIL SAFE

Tumble generated valve control: Not allowed to move tumble generated valve.

9. ECM OPERATION AT DTC SETTING

Memorize the freeze frame data. (For test mode \$02)

DIAGNOSTIC TROUBLE CODE (DTC) DETECTING CRITERIA

GENERAL DESCRIPTION

CS:DTC P1095 — TUMBLE GENERATED VALVE SIGNAL 1 CIRCUIT MALFUNCTION (SHORT) —

1. OUTLINE OF DIAGNOSIS

Detect the open or short circuit of tumble generated valve motor.

Judge NG when the overcurrent signal is sent from IC after tumble generated valve driving IC diagnosis.

2. COMPONENT DESCRIPTION

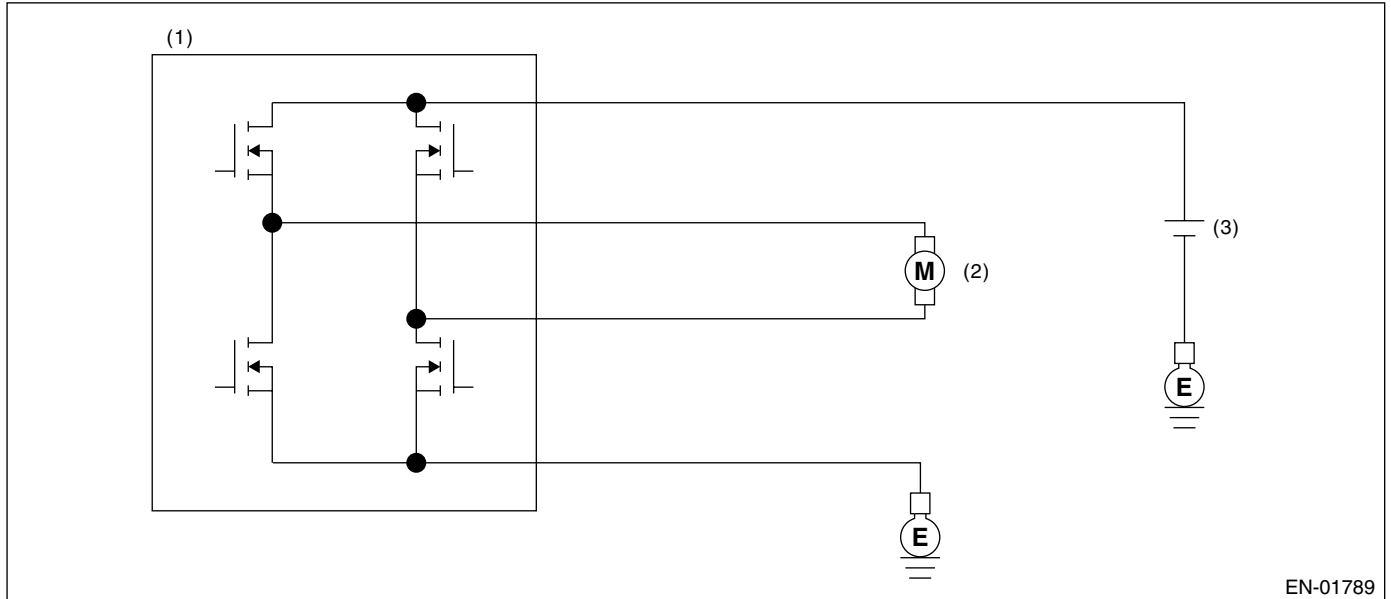

EN-01789

(1) Engine control module (ECM)

(2) Tumble generated valve

(3) Battery

3. ENABLE CONDITION

Secondary Parameters	Enable Conditions
Battery voltage	≥ 10.9 V
ECM output signal	before set ON → OFF
Tumble generated valve ON signal output	20 milliseconds or more

4. GENERAL DRIVING CYCLE

Always perform the diagnosis continuously.

5. DIAGNOSTIC METHOD

NG signal is sent to main IC. At the main IC, check the sent signal at each timing which occurs just before the tumble generated valve output is set to ON and OFF, and judge overcurrent NG when the overcurrent NG signal is sent during 10 seconds in a row. Judge OK and clear the NG when the OK signal is sent.

Judgment Value

Malfunction Criteria	Threshold Value
Open NG signal input	Low
Overcurrent NG signal input	High

Time Needed for Diagnosis: 10 second

Malfunction Indicator Light Illumination: Illuminates as soon as malfunction occurs.

6. DTC CLEAR CONDITION

- When the OK idling cycle was completed 40 times in a row
- When “Clear Memory” was performed

DIAGNOSTIC TROUBLE CODE (DTC) DETECTING CRITERIA

GENERAL DESCRIPTION

7. MALFUNCTION INDICATOR LIGHT CLEAR CONDITION

- When the OK driving cycle was completed 3 times in a row
- When "Clear Memory" was performed

8. FAIL SAFE

Tumble generated valve control: Not allowed to move tumble generated valve.

9. ECM OPERATION AT DTC SETTING

Memorize the freeze frame data. (For test mode \$02)

DIAGNOSTIC TROUBLE CODE (DTC) DETECTING CRITERIA

GENERAL DESCRIPTION

CT:DTC P1096 — TUMBLE GENERATED VALVE SIGNAL 2 CIRCUIT MALFUNCTION (OPEN) —

1. OUTLINE OF DIAGNOSIS

Detect the open or short circuit of tumble generated valve motor.

Judge NG when the open signal is sent from IC after tumble generated valve driving IC diagnosis.

2. COMPONENT DESCRIPTION

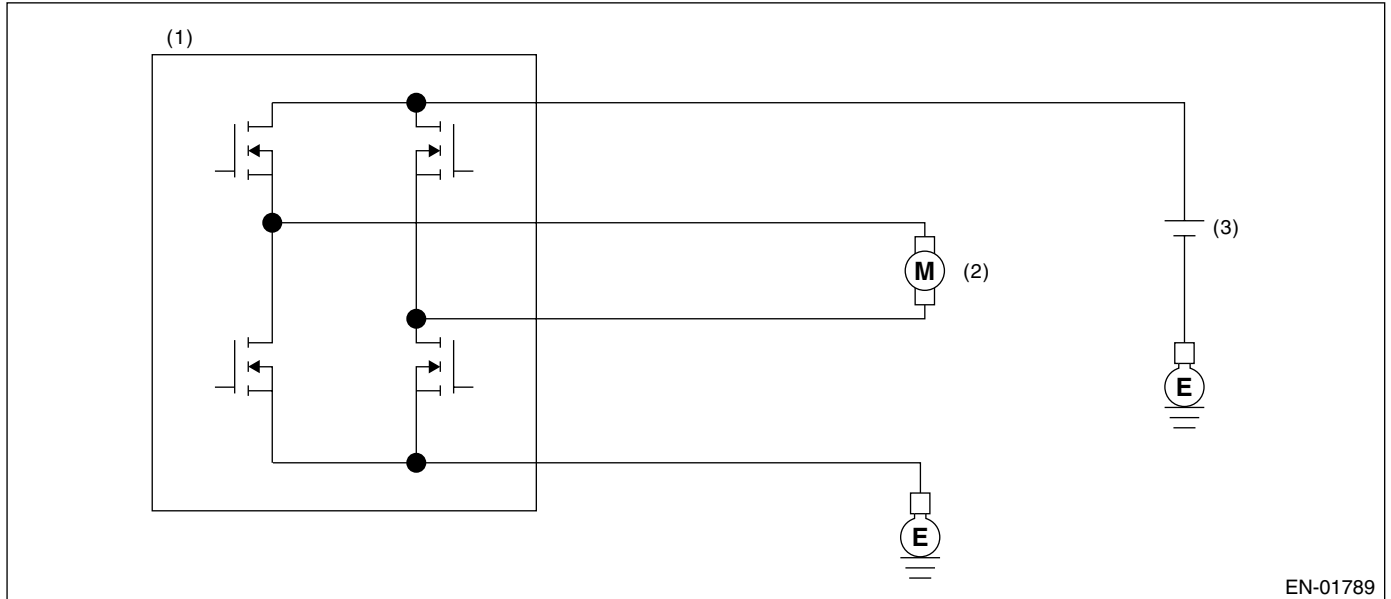

EN-01789

(1) Engine control module (ECM)

(2) Tumble generated valve

(3) Battery

3. ENABLE CONDITION

Secondary Parameters	Enable Conditions
Battery voltage	≥ 10.9 V
ECM output signal	before set ON → OFF
Tumble generated valve ON signal output	20 milliseconds or more

4. GENERAL DRIVING CYCLE

Always perform the diagnosis continuously.

5. DIAGNOSTIC METHOD

Judge NG when the malfunction criteria below are completed by tumble generated valve driving IC, and then NG signal is sent to main IC. At the main IC, check the sent signal at each timing which occurs just before the tumble generated valve output is set to ON and OFF, and judge open NG when the open NG signal is sent during 10 seconds in a row. Judge OK and clear the NG when the OK signal is sent.

Judgment Value

Malfunction Criteria	Threshold Value
Open NG signal input	High
Overcurrent NG signal input	Low

Time Needed for Diagnosis: 10 seconds

Malfunction Indicator Light Illumination: Illuminates as soon as malfunction occurs.

DIAGNOSTIC TROUBLE CODE (DTC) DETECTING CRITERIA

GENERAL DESCRIPTION

6. DTC CLEAR CONDITION

- When the OK idling cycle was completed 40 times in a row
- When "Clear Memory" was performed

7. MALFUNCTION INDICATOR LIGHT CLEAR CONDITION

- When the OK driving cycle was completed 3 times in a row
- When "Clear Memory" was performed

8. FAIL SAFE

Tumble generated valve control: Not allowed to move tumble generated valve.

9. ECM OPERATION AT DTC SETTING

Memorize the freeze frame data. (For test mode \$02)

DIAGNOSTIC TROUBLE CODE (DTC) DETECTING CRITERIA

GENERAL DESCRIPTION

CU:DTC P1097 — TUMBLE GENERATED VALVE SIGNAL 2 CIRCUIT MALFUNCTION (SHORT) —

1. OUTLINE OF DIAGNOSIS

Detect the open or short circuit of tumble generated valve motor.

Judge NG when the overcurrent signal is sent from IC after tumble generated valve driving IC diagnosis.

2. COMPONENT DESCRIPTION

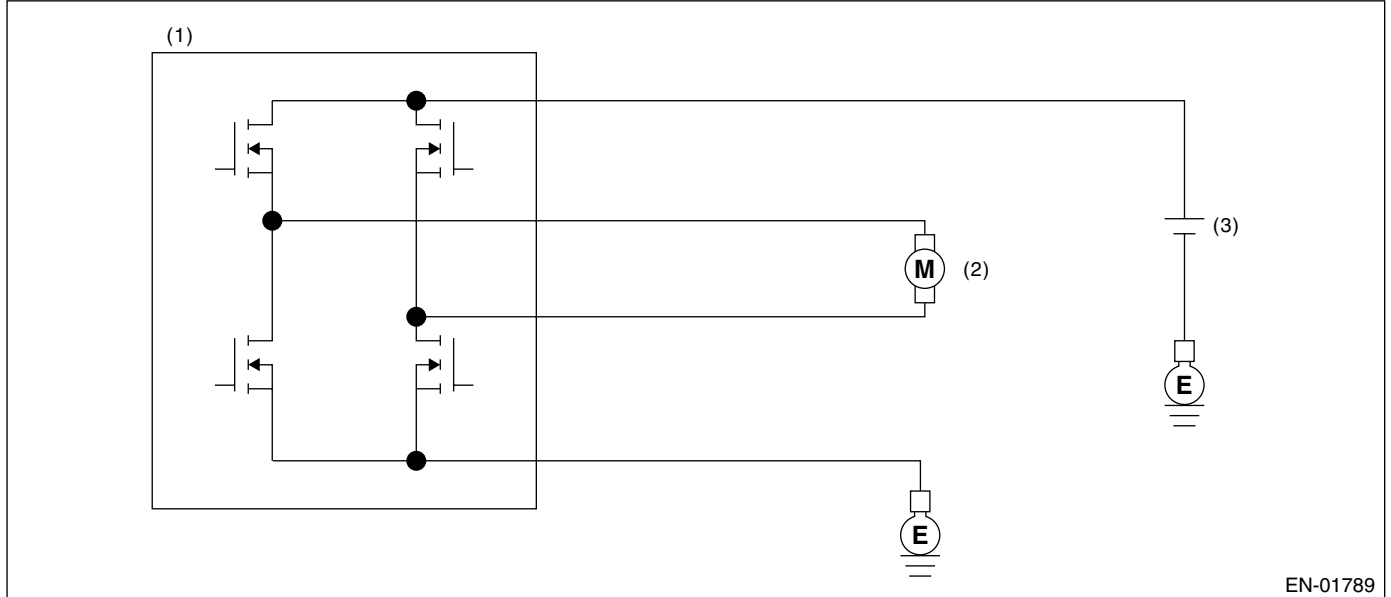

EN-01789

(1) Engine control module (ECM)

(2) Tumble generated valve

(3) Battery

3. ENABLE CONDITION

Secondary Parameters	Enable Conditions
Battery voltage	≥ 10.9 V
ECM output signal	before set ON → OFF
Tumble generated valve ON signal output	20 milliseconds or more

4. GENERAL DRIVING CYCLE

Always perform the diagnosis continuously.

5. DIAGNOSTIC METHOD

Judge NG when the malfunction criteria below are completed by tumble generated valve driving IC, and then NG signal is sent to main IC. At the main IC, check the sent signal at each timing which occurs just before the tumble generated valve output is set to ON and OFF, and judge overcurrent NG when the overcurrent NG signal is sent during 10 seconds in a row.

Judge OK and clear the NG when the OK signal is sent.

Judgment Value

Malfunction Criteria	Threshold Value
Open NG signal input	Low
Overcurrent NG signal input	High

Time Needed for Diagnosis: 10 second

Malfunction Indicator Light Illumination: Illuminates as soon as malfunction occurs.

DIAGNOSTIC TROUBLE CODE (DTC) DETECTING CRITERIA

GENERAL DESCRIPTION

6. DTC CLEAR CONDITION

- When the OK idling cycle was completed 40 times in a row
- When "Clear Memory" was performed

7. MALFUNCTION INDICATOR LIGHT CLEAR CONDITION

- When the OK driving cycle was completed 3 times in a row
- When "Clear Memory" was performed

8. FAIL SAFE

Tumble generated valve control: Not allowed to move tumble generated valve.

9. ECM OPERATION AT DTC SETTING

Memorize the freeze frame data. (For test mode \$02)

DIAGNOSTIC TROUBLE CODE (DTC) DETECTING CRITERIA

GENERAL DESCRIPTION

CV:DTC P1110 — ATMOSPHERIC PRESSURE SENSOR CIRCUIT MALFUNCTION (LOW INPUT) —

1. OUTLINE OF DIAGNOSIS

Detect the open or short circuit of atmospheric pressure sensor.
Judge NG when out of the standard value.

2. COMPONENT DESCRIPTION

Atmospheric pressure sensor is built in ECM.

3. ENABLE CONDITION

Secondary Parameters	Enable Conditions
None	

4. GENERAL DRIVING CYCLE

Always perform the diagnosis continuously.

5. DIAGNOSTIC METHOD

• Abnormality Judgment

Judge NG when the continuous time of completing the malfunction criteria below becomes more than 0.5 seconds.

• Judgment Value

Malfunction Criteria	Threshold Value
Ignition switch	ON
Output voltage	< 0.118 V

Time Needed for Diagnosis: 0.5 seconds

Malfunction Indicator Light Illumination: Illuminates as soon as malfunction occurs.

• Normality Judgment

Judge OK and clear the NG when the malfunction criteria below are completed.

• Judgment Value

Malfunction Criteria	Threshold Value
Ignition switch	ON
Output voltage	≥ 0.118 V

6. DTC CLEAR CONDITION

- When the OK idling cycle was completed 40 times in a row
- When "Clear Memory" was performed

7. MALFUNCTION INDICATOR LIGHT CLEAR CONDITION

- When the OK driving cycle was completed 3 times in a row
- When "Clear Memory" was performed

8. FAIL SAFE

Atmospheric pressure sensor process: Fix the atmospheric pressure to 101.3 kPa (760 mmHg, 29.9 inHg).

9. ECM OPERATION AT DTC SETTING

Memorize the freeze frame data. (For test mode \$02)

DIAGNOSTIC TROUBLE CODE (DTC) DETECTING CRITERIA

GENERAL DESCRIPTION

CW:DTC P1111 — ATMOSPHERIC PRESSURE SENSOR CIRCUIT MALFUNCTION (HIGH INPUT) —

1. OUTLINE OF DIAGNOSIS

Detect the open or short circuit of atmospheric pressure sensor.
Judge NG when out of the standard value.

2. COMPONENT DESCRIPTION

Atmospheric pressure sensor is built in ECM.

3. ENABLE CONDITION

Secondary Parameters	Enable Conditions
None	

4. GENERAL DRIVING CYCLE

Always perform the diagnosis continuously.

5. DIAGNOSTIC METHOD

• Abnormality Judgment

Judge NG when the continuous time of completing the malfunction criteria below becomes more than 0.5 seconds.

• Judgment Value

Malfunction Criteria	Threshold Value
Ignition switch	ON
Output voltage	≥ 4.936 V

Time Needed for Diagnosis: 0.5 seconds

Malfunction Indicator Light Illumination: Illuminates as soon as malfunction occurs.

• Normality Judgment

Judge OK and clear the NG when the malfunction criteria below are completed.

• Judgment Value

Malfunction Criteria	Threshold Value
Ignition switch	ON
Output voltage	< 4.936 V

6. DTC CLEAR CONDITION

- When the OK idling cycle was completed 40 times in a row
- When "Clear Memory" was performed

7. MALFUNCTION INDICATOR LIGHT CLEAR CONDITION

- When the OK driving cycle was completed 3 times in a row
- When "Clear Memory" was performed

8. FAIL SAFE

Atmospheric pressure sensor process: Fix the atmospheric pressure to 101.3 kPa (760 mmHg, 29.9 inHg).

9. ECM OPERATION AT DTC SETTING

Memorize the freeze frame data. (For test mode \$02)

DIAGNOSTIC TROUBLE CODE (DTC) DETECTING CRITERIA

GENERAL DESCRIPTION

CX:DTC P1152 — O₂ SENSOR CIRCUIT RANGE/PERFORMANCE (LOW) (BANK1 SENSOR1) —

1. OUTLINE OF DIAGNOSIS

Detect that lambda value remains Low.

Judge NG when lambda value is abnormal in accordance with lambda value of front oxygen (A/F) sensor and running condition that is vehicle speed, amount of intake air engine coolant temperature, sub feedback control, etc.

Lambda value = Actual air fuel ratio/Theoretical air fuel ratio

Lambda > 1: Lean

Lambda < 1: Rich

2. COMPONENT DESCRIPTION

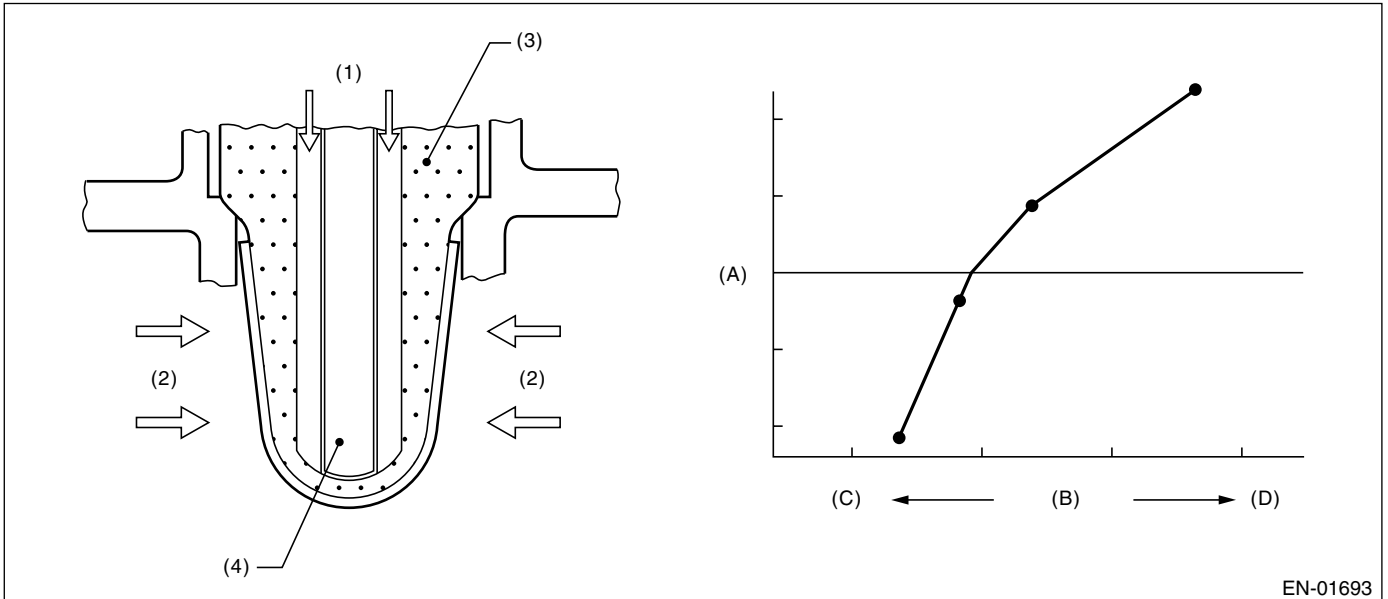

EN-01693

- (1) Atmosphere
- (2) Exhaust
- (3) ZrO₂
- (4) Ceramic heater

- (A) Electromotive force
- (B) Air fuel ratio
- (C) Lean
- (D) Rich

DIAGNOSTIC TROUBLE CODE (DTC) DETECTING CRITERIA

GENERAL DESCRIPTION

3. ENABLE CONDITION

Secondary Parameters	Enable Conditions
All secondary parameters to be in enable conditions	4 seconds or more
Battery voltage	> 10.9 V
Atmospheric pressure	> 75.1 kPa (563 mmHg, 22.2 inHg)
Rear oxygen sensor sub feedback	In operation
Rear oxygen sensor output voltage – feedback target voltage	–0.2 V ↔ 0.1 V
or	
rear oxygen sensor sub feedback compensation coefficient	On Min.
or	
rear oxygen sensor sub feedback compensation coefficient	On Max.
After starting engine	60 seconds or more
Engine coolant temperature	≥ 75°C (167°F)
Vehicle speed	≥ 20 km/h (12 MPH)
Amount of intake air	≥ 6 g (0.21 oz)/s
Load change during 0.5 engine rev.	≤ 0.01 g (0.0003 oz)/rev
Impedance of front oxygen (A/F) sensor	0 ↔ 50 Ω
Learning value of evaporation gas density	≤ 0.2
Total time of operating canister purge	20 seconds or more

4. GENERAL DRIVING CYCLE

Perform diagnosis continuously at a constant speed of 20 km/h (12 MPH) or more since 60 seconds after starting the engine.

5. DIAGNOSTIC METHOD

Judge NG when the continuous time of completing the malfunction criteria below becomes more than the time needed for diagnosis (10 seconds). Judge OK and clear NG when the malfunction criteria below are not completed.

Judgment Value

Malfunction Criteria	Threshold Value
Output lambda when rear oxygen sensor sub feedback compensation coefficient being at not high limit	≤ 0.85

Time Needed for Diagnosis: 10 seconds

Malfunction Indicator Light Illumination: Illuminates when malfunction occurs in 2 continuous driving cycles.

6. DTC CLEAR CONDITION

- When the OK idling cycle was completed 40 times in a row
- When “Clear Memory” was performed

7. MALFUNCTION INDICATOR LIGHT CLEAR CONDITION

- When the OK driving cycle was completed 3 times in a row
- When “Clear Memory” was performed

DIAGNOSTIC TROUBLE CODE (DTC) DETECTING CRITERIA

GENERAL DESCRIPTION

8. FAIL SAFE

- Front oxygen (A/F) sensor main learning correction: Not allowed to calculate
- Correction when re-starting at high temperature: Normally minimum value 0.3 → 0
- Purge control: Not allowed to purge

9. ECM OPERATION AT DTC SETTING

Memorize the freeze frame data. (For test mode \$02)

DIAGNOSTIC TROUBLE CODE (DTC) DETECTING CRITERIA

GENERAL DESCRIPTION

MEMO:

DIAGNOSTIC TROUBLE CODE (DTC) DETECTING CRITERIA

GENERAL DESCRIPTION

CY:DTC P1153 — O₂ SENSOR CIRCUIT RANGE/PERFORMANCE (HIGH) (BANK1 SENSOR1) —

1. OUTLINE OF DIAGNOSIS

Detect that lambda value remains High.

Judge NG when lambda value is abnormal in accordance with lambda value of front oxygen (A/F) sensor and running condition that is vehicle speed, amount of intake air engine coolant temperature, sub feedback control, etc.

Lambda value = Actual air fuel ratio/Theoretical air fuel ratio

Lambda > 1: Lean

Lambda < 1: Rich

2. COMPONENT DESCRIPTION

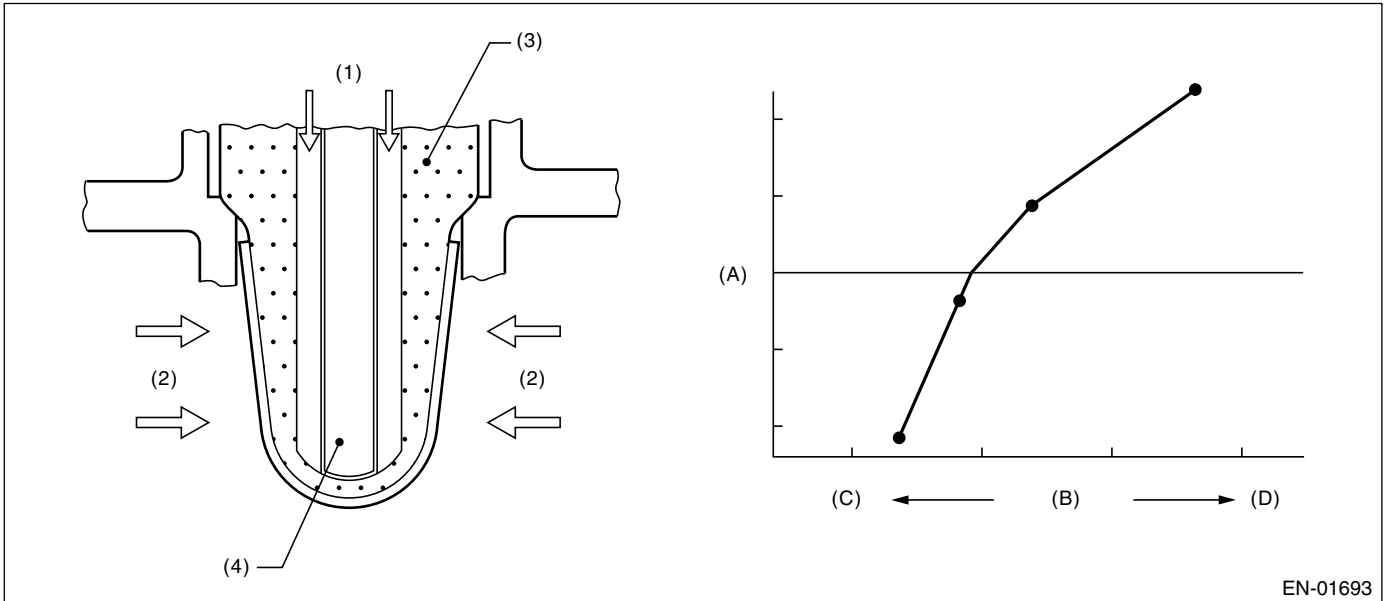

EN-01693

- (1) Atmosphere
- (2) Exhaust
- (3) ZrO₂
- (4) Ceramic heater

- (A) Electromotive force
- (B) Air fuel ratio
- (C) Lean
- (D) Rich

DIAGNOSTIC TROUBLE CODE (DTC) DETECTING CRITERIA

GENERAL DESCRIPTION

3. ENABLE CONDITION

Secondary Parameters	Enable Conditions
All secondary parameters to be in enable conditions	4 seconds or more
Battery voltage	> 10.9 V
Atmospheric pressure	> 75.1 kPa (563 mmHg, 22.2 inHg)
Rear oxygen sensor sub feedback	In operation
Rear oxygen sensor output voltage – feedback target voltage	–0.2 V ↔ 0.1 V
or	
rear oxygen sensor sub feedback compensation coefficient	On Min.
or	
rear oxygen sensor sub feedback compensation coefficient	On Max.
After engine starting	60 seconds or more
Engine coolant temperature	≥ 75°C (167°F)
Vehicle speed	≥ 20 km/h (12 MPH)
Amount of intake air	≥ 6 g (0.21 oz)/s
Load change during 0.5 engine rev.	≤ 0.01 g (0.0003 oz)/rev
Impedance of front oxygen (A/F) sensor	0 ↔ 50 Ω
Learning value of evaporation gas density	≤ 0.2
Total time of operating canister purge	20 seconds or more

4. GENERAL DRIVING CYCLE

Perform diagnosis continuously at a constant speed of 20 km/h (12 MPH) or more since 60 seconds after starting the engine.

5. DIAGNOSTIC METHOD

Judge NG when the continuous time of completing the malfunction criteria below becomes more than the time needed for diagnosis (10 seconds). Judge OK and clear NG when the malfunction criteria below are not completed.

Judgment Value

Malfunction Criteria	Threshold Value
Output lambda when rear O ₂ sensor sub feedback compensation coefficient value being at not low limit	≥ 1.15

Time Needed for Diagnosis: 10 seconds

Malfunction Indicator Light Illumination: Illuminates when malfunction occurs in 2 continuous driving cycles.

6. DTC CLEAR CONDITION

- When the OK idling cycle was completed 40 times in a row
- When “Clear Memory” was performed

7. MALFUNCTION INDICATOR LIGHT CLEAR CONDITION

- When the OK driving cycle was completed 3 times in a row
- When “Clear Memory” was performed

DIAGNOSTIC TROUBLE CODE (DTC) DETECTING CRITERIA

GENERAL DESCRIPTION

8. FAIL SAFE

- Front oxygen (A/F) sensor main learning correction: Not allowed to calculate
- Correction when re-starting at high temperature: Normally minimum value 0.3 → 0
- Purge control: Not allowed to purge

9. ECM OPERATION AT DTC SETTING

Memorize the freeze frame data. (For test mode \$02)

DIAGNOSTIC TROUBLE CODE (DTC) DETECTING CRITERIA

GENERAL DESCRIPTION

MEMO:

DIAGNOSTIC TROUBLE CODE (DTC) DETECTING CRITERIA

GENERAL DESCRIPTION

CZ:DTC P1160 — RETURN SPRING FAILURE —

1. OUTLINE OF DIAGNOSIS

Judge NG when the valve does not move to the close direction with the motor power stopped and the valve open more than the default opening.

2. COMPONENT DESCRIPTION

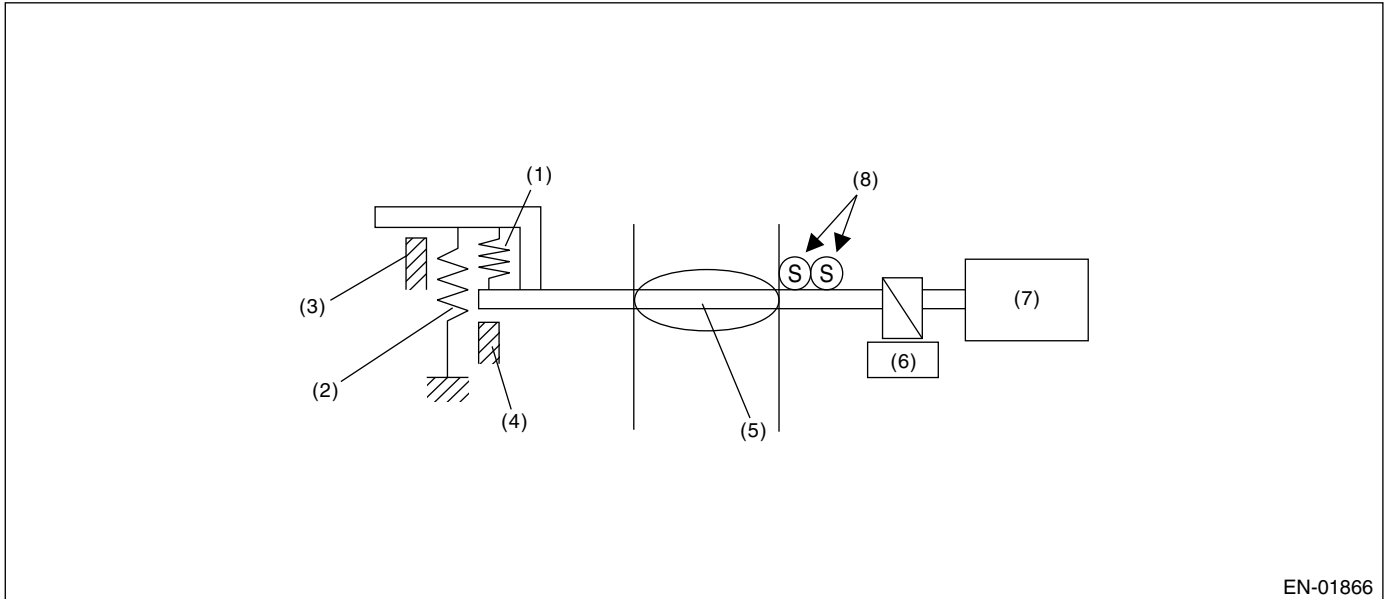

- | | | |
|--------------------------|-------------------------|----------------------------------|
| (1) Opener spring | (4) Full closed stopper | (7) DC motor |
| (2) Return spring | (5) Throttle valve | (8) Main and sub throttle sensor |
| (3) Intermediate stopper | (6) Gear | |

3. ENABLE CONDITION

Secondary Parameters	Enable Conditions
Throttle opening	OFF
Motor continuity	OFF

4. GENERAL DRIVING CYCLE

- Ignition switch ON → OFF
- Ignition switch OFF → ON (After clear memory only)

5. DIAGNOSTIC METHOD

• Abnormality Judgment

Judge NG when the continuous time of completing the malfunction criteria below becomes more than 0.5 seconds.

• Judgment Value

Malfunction Criteria	Threshold Value
Opening variation after continuity is set to OFF	$\geq 2^\circ$

Time Needed for Diagnosis: 600 milliseconds

Malfunction Indicator Light Illumination: Illuminates as soon as malfunction occurs.

6. DTC CLEAR CONDITION

- When the OK idling cycle was completed 40 times in a row
- When "Clear Memory" was performed (Only engine stop)

DIAGNOSTIC TROUBLE CODE (DTC) DETECTING CRITERIA

GENERAL DESCRIPTION

7. MALFUNCTION INDICATOR LIGHT CLEAR CONDITION

- When the OK driving cycle was completed 3 times in a row
- When "Clear Memory" was performed (Only engine stop)

8. FAIL SAFE

Fix the throttle opening to 6°.

9. ECM OPERATION AT DTC SETTING

Memorize the freeze frame data. (For test mode \$02)

DIAGNOSTIC TROUBLE CODE (DTC) DETECTING CRITERIA

GENERAL DESCRIPTION

DA:DTC P1301 — MISFIRE DETECTED (HIGH TEMPERATURE EXHAUST GAS)

1. OUTLINE OF DIAGNOSIS

Detect whether the misfire occurred or not. (Exhaust temperature method)
Judge NG when the exhaust temperature is high.

2. ENABLE CONDITION

Secondary Parameters	Enable Conditions
All secondary parameters approval continuation time	1 second or more
Intake manifold pressure change during 0.5 engine rev.	< 16.0 kPa (120 mmHg, 4.72 inHg) (MT) < 14.7 kPa (110 mmHg, 4.33 inHg) (AT)
Engine speed change	< 500 rpm/32 milliseconds
Throttle position change during 16 milliseconds	< 10°
Fuel shut-off function	Not in operation
Atmospheric pressure	≥ 75.1 kPa (563 mmHg, 22.2 inHg)
Fuel level	≥ 9.6 ℓ (2.54 US gal, 2.11 Imp gal)
Air conditioner	No switching ON ↔ OFF
Radiator fan	No switching ON ↔ OFF
Power steering switch	No switching ON ↔ OFF
Starter	ON, OFF, or change from ON to OFF
Evaporative system leak check	Not in operation
Engine speed	500 — 6700 rpm
Intake manifold pressure	> Map3 or more
Battery voltage	≥ 8 V
Engine coolant temperature	≥ 111°C (232°F)
Intake air temperature	≥ 101°C (214°F)
Heavy quality fuel judgement	Does not execute.
VDC and AT control	Is not torque controlling.

DIAGNOSTIC TROUBLE CODE (DTC) DETECTING CRITERIA

GENERAL DESCRIPTION

Map3

- MT

Vehicle Speed < 64.4 km/h (40 MPH)

rpm	700	1000	1500	2000	2500	3000	3500	4000	4500	5000	5500	6000	6500	6700
kPa	25.1	24.8	25.6	23.3	26.3	25.9	28.9	30.0	31.7	33.0	37.1	41.9	47.0	51.1
(mmHg, inHg)	(188, 7.40)	(186, 7.32)	(192, 7.56)	(175, 6.89)	(197, 7.76)	(194, 7.64)	(216.5, 8.52)	(225, 8.86)	(237.5, 9.35)	(248, 9.76)	(278.5, 11.0)	(314, 12.4)	(352.5, 13.9)	(383, 15.1)

Vehicle Speed ≥ 64.4 km/h (40 MPH)

rpm	700	1000	1500	2000	2500	3000	3500	4000	4500	5000	5500	6000	6500	6700
kPa	25.5	25.1	30.4	35.6	38.5	40.4	41.1	40.8	44.8	47.3	49.1	50.9	52.8	52.8
(mmHg, inHg)	(191, 7.52)	(188, 7.40)	(227.7, 8.96)	(267.4, 10.5)	(288.9, 11.4)	(302.9, 11.9)	(308.6, 12.1)	(306, 12.0)	(335.8, 13.2)	(354.5, 14.0)	(368.2, 14.5)	(381.9, 15.0)	(396, 15.6)	(396, 15.6)

- AT

Vehicle Speed ≥ 64.4 km/h (40 MPH)

rpm	700	1000	1500	2000	2500	3000	3500	4000	4500	5000	5500	6000	6500	6700
kPa	26.3	24.8	23.6	25.5	27.3	26.1	29.5	31.3	32.7	33.3	38.2	33.6	49.5	51.5
(mmHg, inHg)	(197, 7.76)	(186, 7.32)	(177, 6.97)	(191, 7.52)	(205, 8.07)	(196, 7.72)	(221.5, 8.72)	(235, 9.25)	(245.5, 9.67)	(250, 9.84)	(286.5, 11.3)	(252.3, 9.93)	(371.5, 14.62)	(386, 15.20)

3. GENERAL DRIVING CYCLE

- Detecting misfire is able to be carried out in the condition between idling and high revolution.
- Always perform the diagnosis continuously.

4. DIAGNOSTIC METHOD

Judge NG when the malfunction criteria below continue 200 engine revs. (400 ignitions) in a row.

Judgment Value

Malfunction Criteria	Threshold Value
Exhaust temperature	> 1050°C (1922°F)

Time Needed for Diagnosis: 200 engine revs.

Malfunction Indicator Light Illumination: Illuminates as soon as malfunction occurs.

5. DTC CLEAR CONDITION

- When the OK idling cycle was completed 40 times in a row
- When "Clear Memory" was performed

6. MALFUNCTION INDICATOR LIGHT CLEAR CONDITION

- When the OK driving cycle was completed 3 times in a row
- When "Clear Memory" was performed

7. FAIL SAFE

None

8. ECM OPERATION AT DTC SETTING

Memorize the freeze frame data. (For test mode \$02)

DIAGNOSTIC TROUBLE CODE (DTC) DETECTING CRITERIA

GENERAL DESCRIPTION

DB:DTC P1312 — EXHAUST GAS TEMPERATURE SENSOR MALFUNCTION —

1. OUTLINE OF DIAGNOSIS

Detect the malfunction of exhaust temperature sensor output property.

Judge NG when the exhaust temperature remains high or low whereas it seemed to vary from the viewpoint of driving condition.

2. ENABLE CONDITION

Secondary Parameters	Enable Conditions
After starting engine	240 seconds or more
Engine coolant temperature at engine start	$\leq 40^{\circ}\text{C}$ (104°F)
Engine coolant temperature	$\geq 75^{\circ}\text{C}$ (167°F)
Intake air temperature at engine start	$\geq 0^{\circ}\text{C}$ (32°F)
Estimate ambient temperature	$\geq 0^{\circ}\text{C}$ (32°F)
Engine speed	≥ 2400 rpm
Engine load	≥ 0.85 g (0.030 oz)/rev
Lambda value	0.75 \leftrightarrow 1.25

3. GENERAL DRIVING CYCLE

Perform the diagnosis continuously at more than 2400 rpm of engine speed in 240 seconds and more after starting the engine in cool condition.

Pay attention to the coolant temperature at engine starting.

4. DIAGNOSTIC METHOD

Judge NG when one of the malfunction criteria below is completed, and judge OK and clear the NG when all of the malfunction criteria below are not completed.

Judgment Value

Malfunction Criteria	Threshold Value
Min. exhaust temperature from engine starting	$\geq 700^{\circ}\text{C}$ (1292°F)
Max. exhaust temperature from engine starting	$< 500^{\circ}\text{C}$ (932°F)

Time Needed for Diagnosis: 0 seconds

Malfunction Indicator Light Illumination: Illuminates as soon as malfunction occurs.

5. DTC CLEAR CONDITION

- When the OK idling cycle was completed 40 times in a row
- When "Clear Memory" was performed

6. MALFUNCTION INDICATOR LIGHT CLEAR CONDITION

- When the OK driving cycle was completed 3 times in a row
- When "Clear Memory" was performed

7. FAIL SAFE

None

8. ECM OPERATION AT DTC SETTING

Memorize the freeze frame data. (For test mode \$02)

DIAGNOSTIC TROUBLE CODE (DTC) DETECTING CRITERIA

GENERAL DESCRIPTION

MEMO:

DIAGNOSTIC TROUBLE CODE (DTC) DETECTING CRITERIA

GENERAL DESCRIPTION

DC:DTC P1400 — FUEL TANK PRESSURE CONTROL SOLENOID VALVE CIRCUIT LOW —

1. OUTLINE OF DIAGNOSIS

Detect open or short circuit of pressure control solenoid valve. Judge NG when ECM output level is different from actual terminal level.

2. COMPONENT DESCRIPTION

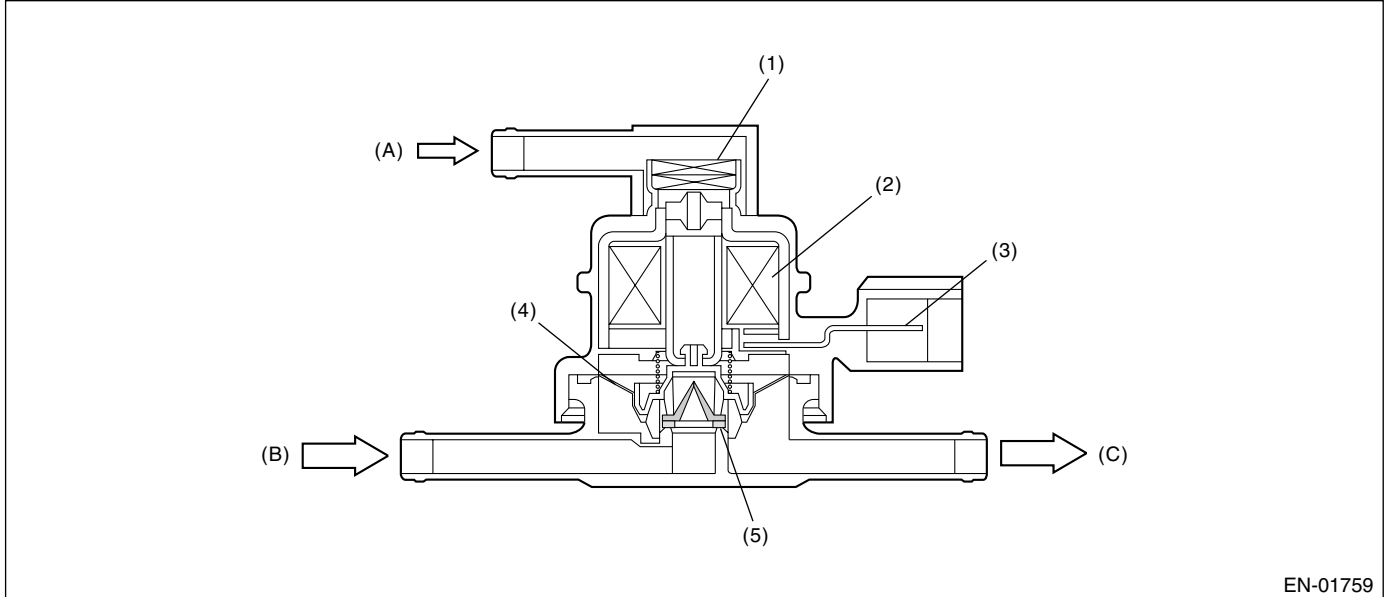

- | | | |
|------------------------|---------------|--------------------------|
| (1) Filter | (4) Diaphragm | (A) Atmospheric pressure |
| (2) Coil | (5) Valve | (B) Shut off valve |
| (3) Connector terminal | | (C) To fuel tank |

3. ENABLE CONDITION

Secondary Parameters	Enable Conditions
Ignition switch	ON
Battery voltage	$\geq 10.9 \text{ V}$
After starting engine	1 second or more

4. GENERAL DRIVING CYCLE

Always perform the diagnosis after starting the engine.

5. DIAGNOSTIC METHOD

Judge NG when the continuous time of completing the malfunction criteria below becomes more than time needed for diagnosis (2.5 seconds). Judge OK and clear the NG when the malfunction criteria below are not completed.

Judgment Value

Malfunction Criteria	Threshold Value
Terminal voltage when ECM outputs off signal	Low

Time Needed for Diagnosis: 2.5 seconds

Malfunction Indicator Light Illumination: Illuminates when malfunction occurs in two continuous drive cycles.

DIAGNOSTIC TROUBLE CODE (DTC) DETECTING CRITERIA

GENERAL DESCRIPTION

6. DTC CLEAR CONDITION

- When the OK idling cycle was completed 40 times in a row
- When "Clear Memory" was performed

7. MALFUNCTION INDICATOR LIGHT CLEAR CONDITION

- When the OK driving cycle was completed 3 times in a row
- When "Clear Memory" was performed

8. FAIL SAFE

None

9. ECM OPERATING AT DTC SETTING

Memorize the freeze frame data. (For test mode \$02)

DIAGNOSTIC TROUBLE CODE (DTC) DETECTING CRITERIA

GENERAL DESCRIPTION

DD:DTC P1420 — FUEL TANK PRESSURE CONTROL SOL. VALVE CIRCUIT HIGH —

1. OUTLINE OF DIAGNOSIS

Detect open or short circuit of pressure control solenoid valve.
Judge NG when ECM output level is different from actual terminal level.

2. COMPONENT DESCRIPTION

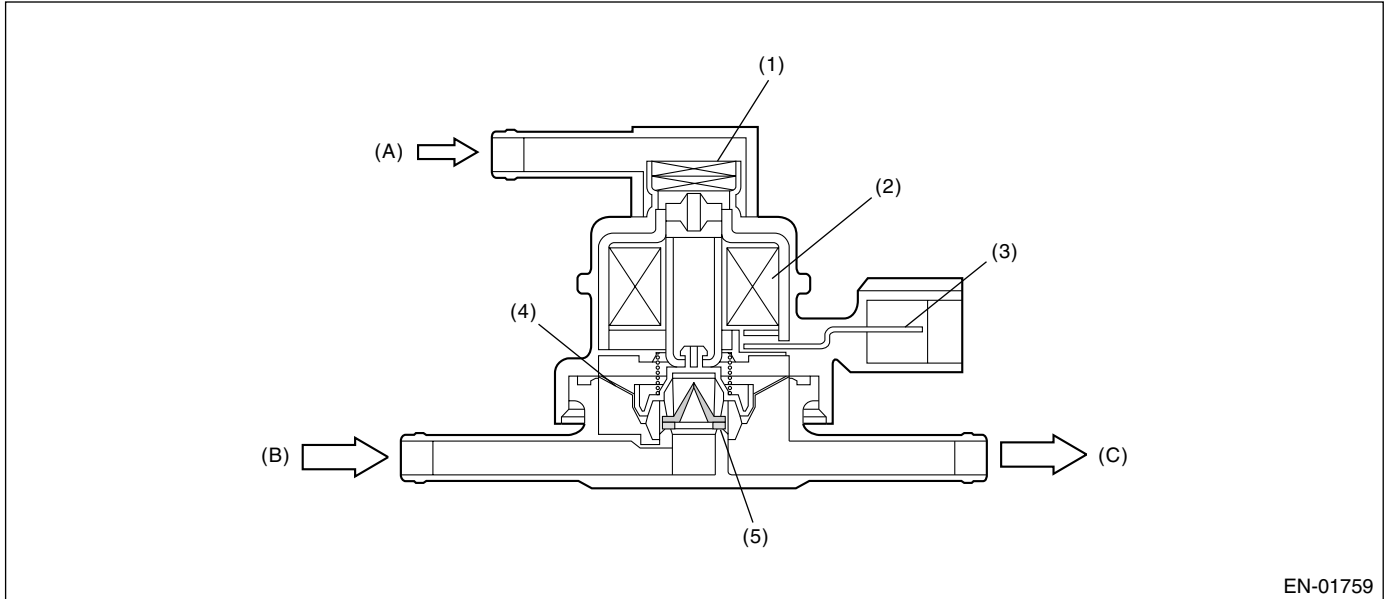

- | | | |
|------------------------|---------------|--------------------------|
| (1) Filter | (4) Diaphragm | (A) Atmospheric pressure |
| (2) Coil | (5) Valve | (B) Shut off valve |
| (3) Connector terminal | | (C) To fuel tank |

3. ENABLE CONDITION

Secondary Parameters	Enable Conditions
Ignition switch	ON
Battery voltage	≥ 10.9 V
After starting engine	1 second or more

4. GENERAL DRIVING CYCLE

Always perform the diagnosis after starting the engine.

5. DIAGNOSTIC METHOD

Judge NG when the continuous time of completing the malfunction criteria below becomes more than time needed for diagnosis (2.5 seconds). Judge OK and clear the NG when the malfunction criteria below are not completed.

Judgment Value

Malfunction Criteria	Threshold Value
Terminal voltage when ECM outputs off signal	High

Time Needed for Diagnosis: 2.5 seconds

Malfunction Indicator Light Illumination: Illuminates when malfunction occurs in two continuous drive cycles.

DIAGNOSTIC TROUBLE CODE (DTC) DETECTING CRITERIA

GENERAL DESCRIPTION

6. DTC CLEAR CONDITION

- When the OK idling cycle was completed 40 times in a row
- When "Clear Memory" was performed

7. MALFUNCTION INDICATOR LIGHT CLEAR CONDITION

- When the OK driving cycle was completed 3 times in a row
- When "Clear Memory" was performed

8. FAIL SAFE

None

9. ECM OPERATING AT DTC SETTING

Memorize the freeze frame data. (For test mode \$02)

DIAGNOSTIC TROUBLE CODE (DTC) DETECTING CRITERIA

GENERAL DESCRIPTION

DE:DTC P1443 — VENT CONTROL SOLENOID VALVE FUNCTION PROBLEM —

1. OUTLINE OF DIAGNOSIS

For detecting conditions, refer to DTC P0442 EVAPORATIVE EMISSION CONTROL SYSTEM LEAK DETECTED (SMALL LEAK). <Ref. to GD(H4DOTC)-128, DTC P0442 — EVAPORATIVE EMISSION CONTROL SYSTEM LEAK DETECTED (SMALL LEAK) —.>

DIAGNOSTIC TROUBLE CODE (DTC) DETECTING CRITERIA

GENERAL DESCRIPTION

MEMO:

DIAGNOSTIC TROUBLE CODE (DTC) DETECTING CRITERIA

GENERAL DESCRIPTION

DF:DTC P1446 — FUEL TANK SENSOR CONTROL VALVE CIRCUIT LOW —

1. OUTLINE OF DIAGNOSIS

Detect the open or short circuit of tank pressure switching solenoid.
Judge NG when the ECM output level is different from actual terminal level.

2. COMPONENT DESCRIPTION

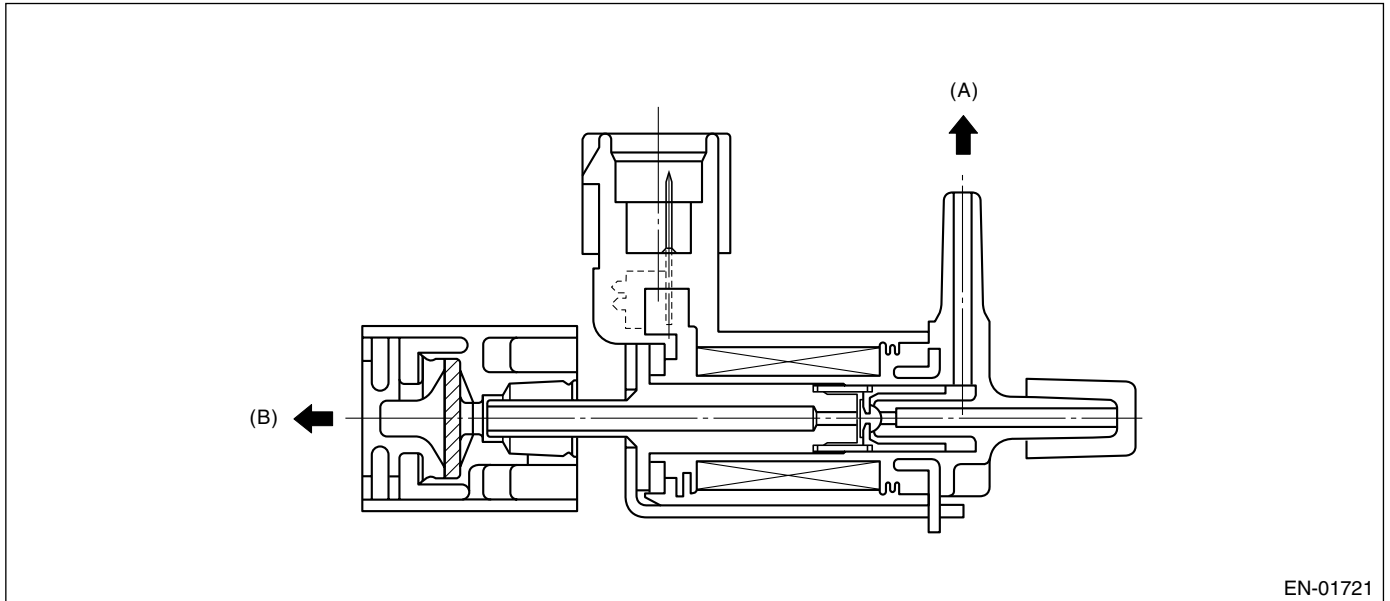

(A) Fuel tank pressure sensor

(B) Ambient air

3. ENABLE CONDITION

Secondary Parameters	Enable Conditions
None	

4. GENERAL DRIVING CYCLE

Always perform the diagnosis continuously.

DIAGNOSTIC TROUBLE CODE (DTC) DETECTING CRITERIA

GENERAL DESCRIPTION

5. DIAGNOSTIC METHOD

• Abnormality Judgment

Judge NG when the continuous time of completing the malfunction criteria below becomes more than 2.5 seconds.

• Judgment Value

Malfunction Criteria	Threshold Value
Battery voltage	≥ 10.9 V
After starting engine	1 second or more
Terminal output voltage when ECM sent OFF signals	Low
Ignition switch	ON

Time Needed for Diagnosis: 2.5 seconds

Malfunction Indicator Light Illumination: Illuminates when malfunction occurs in 2 continuous driving cycles.

• Normality Judgment

Judge OK when the malfunction criteria below are completed.

• Judgment Value

Malfunction Criteria	Threshold Value
Battery voltage	≥ 10.9 V
After starting engine	1 second or more
Terminal output voltage when ECM sent OFF signals	High
Ignition switch	ON

6. DTC CLEAR CONDITION

- When the OK idling cycle is completed 40 times in a row
- When "Clear Memory" was performed

7. MALFUNCTION INDICATOR LIGHT CLEAR CONDITION

- When the OK driving cycle is completed 3 times in a row
- When "Clear Memory" was performed

8. FAIL SAFE

None

9. ECM OPERATION AT DTC SETTING

Memorize the freeze frame data. (For test mode \$02)

DIAGNOSTIC TROUBLE CODE (DTC) DETECTING CRITERIA

GENERAL DESCRIPTION

DG:DTC P1447 — FUEL TANK SENSOR CONTROL VALVE CIRCUIT HIGH —

1. OUTLINE OF DIAGNOSIS

Detect the open or short circuit of tank pressure switching solenoid.
Judge NG when the ECM output level is different from actual terminal level.

2. COMPONENT DESCRIPTION

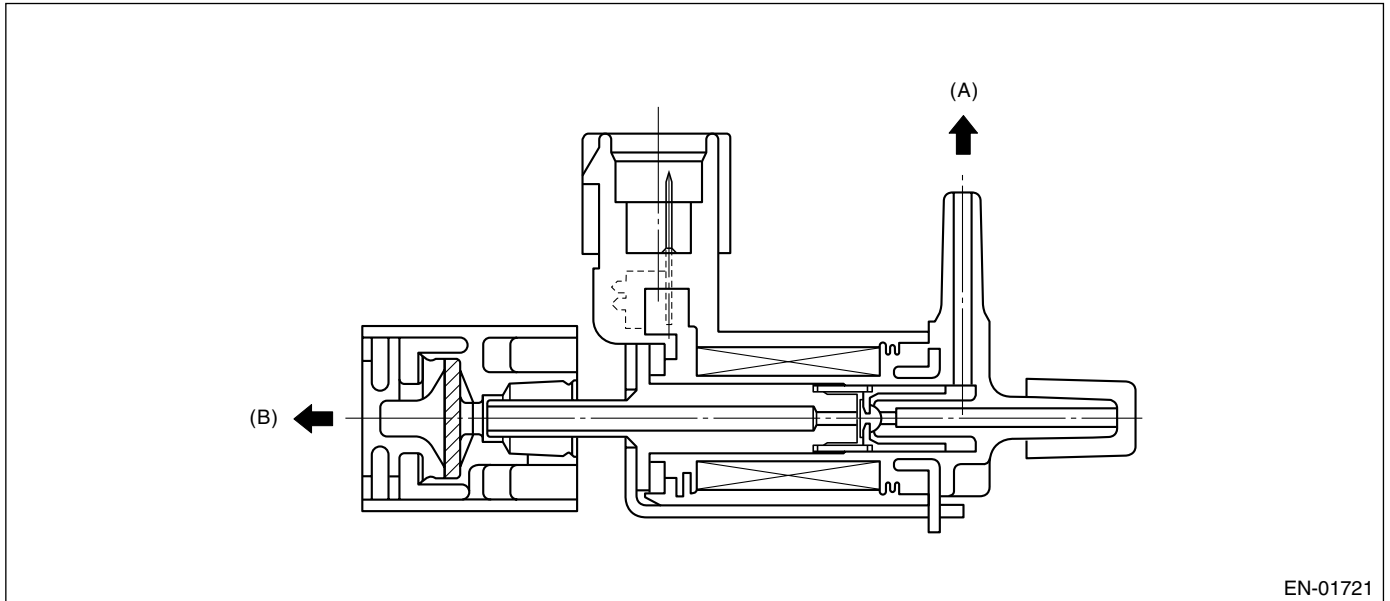

(A) Fuel tank pressure sensor

(B) Ambient air

3. ENABLE CONDITION

Secondary Parameters	Enable Conditions
None	

4. GENERAL DRIVING CYCLE

Always perform the diagnosis continuously.

DIAGNOSTIC TROUBLE CODE (DTC) DETECTING CRITERIA

GENERAL DESCRIPTION

5. DIAGNOSTIC METHOD

• Abnormality Judgment

Judge NG when the cumulative time of completing the malfunction criteria below becomes more than 2.5 seconds.

• Judgment Value

Malfunction Criteria	Threshold Value
Battery voltage	≥ 10.9 V
After starting engine	1 second or more
Terminal output voltage when ECM sent ON signals	High
Ignition switch	ON

Time Needed for Diagnosis: 2.5 seconds

Malfunction Indicator Light Illumination: Illuminates when malfunction occurs in two continuous drive cycles.

• Normality Judgment

Judge OK when the malfunction criteria below are completed.

• Judgment Value

Malfunction Criteria	Threshold Value
Battery voltage	≥ 10.9 V
After starting engine	1 second or more
Terminal output voltage when ECM sent OFF signals	Low
Ignition switch	ON

6. DTC CLEAR CONDITION

- When the OK idling cycle is completed 40 times in a row
- When "Clear Memory" was performed

7. MALFUNCTION INDICATOR LIGHT CLEAR CONDITION

- When the OK driving cycle is completed 3 times in a row
- When "Clear Memory" was performed

8. FAIL SAFE

None

9. ECM OPERATION AT DTC SETTING

Memorize the freeze frame data. (For test mode \$02)

DIAGNOSTIC TROUBLE CODE (DTC) DETECTING CRITERIA

GENERAL DESCRIPTION

DH:DTC P1448 — FUEL TANK SENSOR CONTROL VALVE RANGE PERFORMANCE —

1. OUTLINE OF DIAGNOSIS

Detect the tank pressure switching solenoid function abnormality.

The tank pressure sensor is a relative pressure sensor, which normally compares the pressure with the atmospheric pressure. The tank pressure switching solenoid is a solenoid, which shifts the compare space from opening to closed during the EVAP diagnosis. Detect the malfunction that the compare space remains closed. (Not judge NG after enable condition completed but assume NG before enable condition completed.)

• Normality Judgment

Judge OK when the fuel tank pressure does not change (or changes by less than 0.67 kPa (5 mmHg, 0.2 inHg)) at atmospheric pressure changing by 0.67 kPa (5 mmHg, 0.2 inHg) or more per 80 seconds.

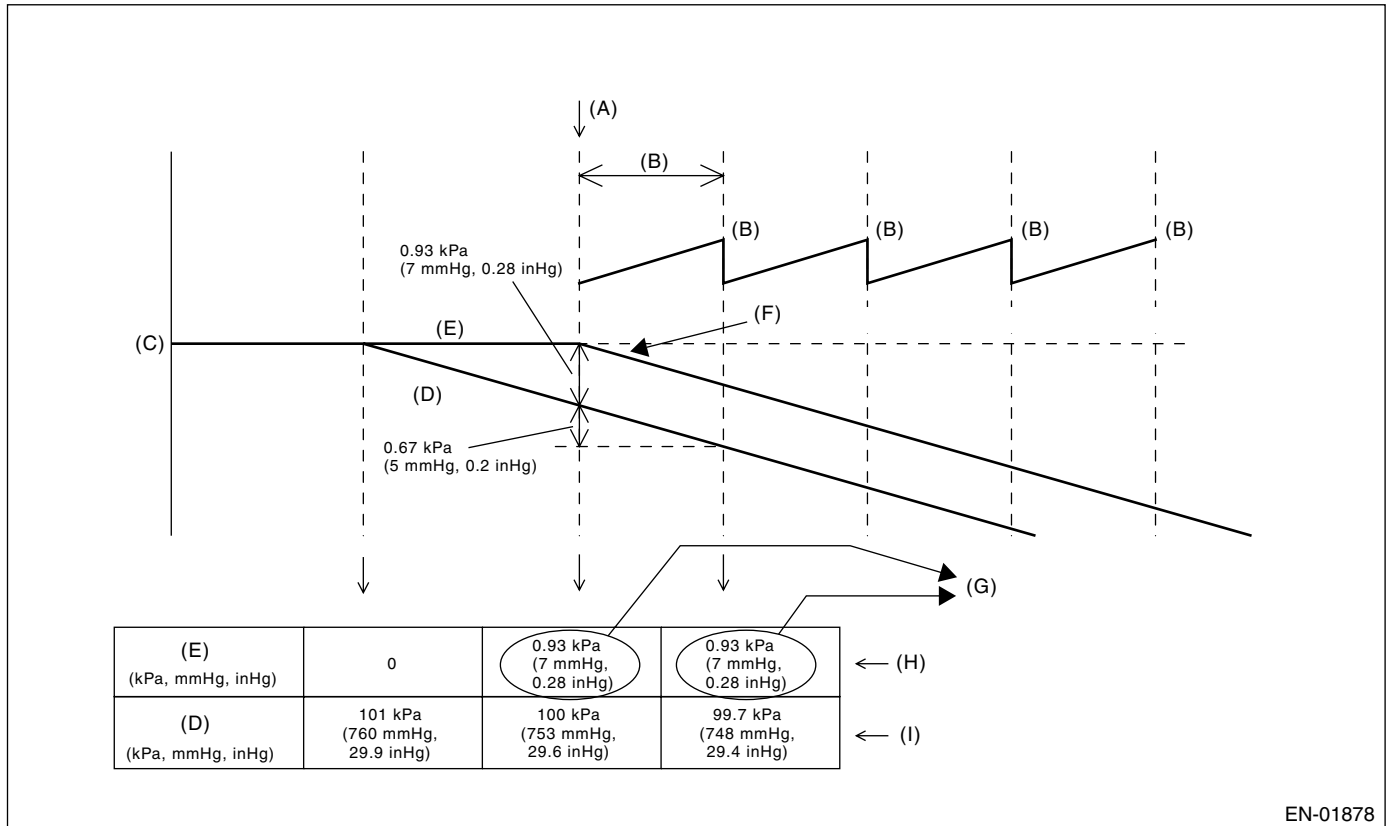

EN-01878

- | | | |
|--------------------------------------|--|---|
| (A) Enable conditions are completed. | (F) PCV function reduces the tank pressure | (H) The tank pressure is relative pressure against atmospheric pressure |
| (B) 80S | (G) Judge OK when the tank pressure does not change. | (I) Change of atmospheric pressure |
| (C) Pressure | | |
| (D) Atmospheric pressure | | |
| (E) Tank pressure | | |

DIAGNOSTIC TROUBLE CODE (DTC) DETECTING CRITERIA

GENERAL DESCRIPTION

• Abnormality Judgment

Judge NG temporarily when the fuel tank pressure changes by 0.67 kPa (5 mmHg, 0.2 inHg) or more at atmospheric pressure changing by 0.67 kPa (5 mmHg, 0.2 inHg) or more per 80 seconds, and then judge NG when the previous condition is completed 5 times in a row.

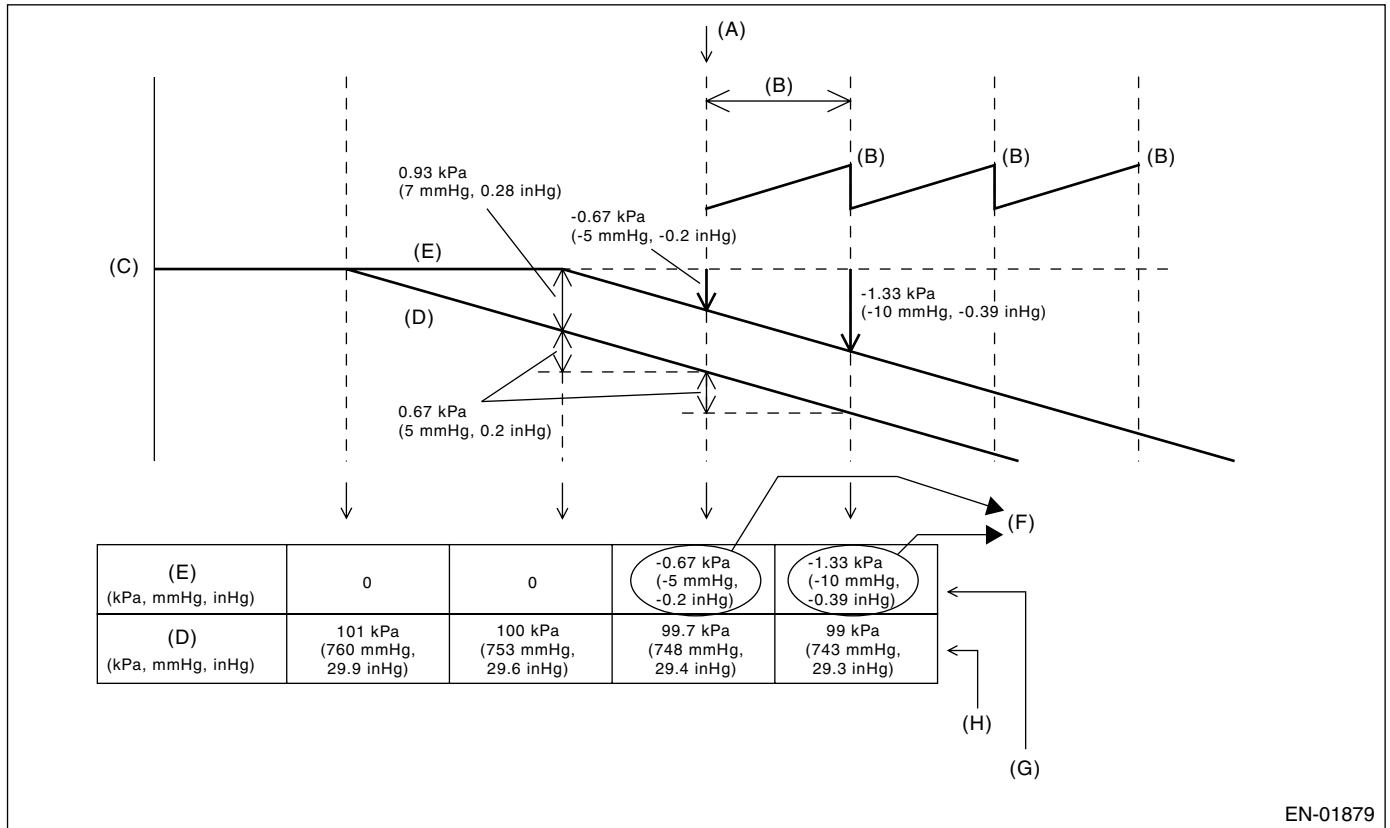

EN-01879

- (A) Enable conditions are completed.
- (B) 80S
- (C) Pressure
- (D) Atmospheric pressure
- (E) Tank pressure
- (F) Judge NG temporarily the tank pressure changes once, and then judge NG the tank pressure changes five consecutive times
- (G) The tank pressure is relative pressure against atmospheric pressure. Ordinary, part of pressure comparison is atmospheric pressure. 101 kPa (760 mmHg, 29.9 inHg).
- (H) Atmospheric pressure is absolute pressure.

DIAGNOSTIC TROUBLE CODE (DTC) DETECTING CRITERIA

GENERAL DESCRIPTION

2. COMPONENT DESCRIPTION

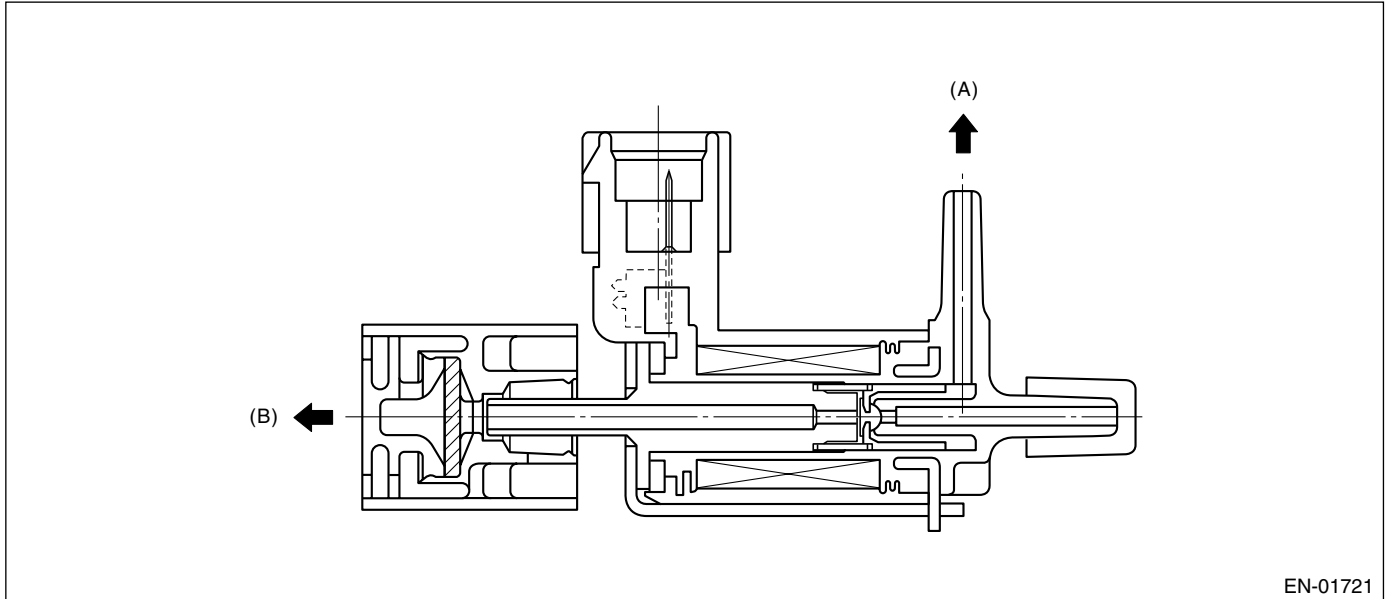

(A) Fuel tank pressure sensor

(B) Ambient air

3. ENABLE CONDITION

Secondary Parameter	Enable Condition
Battery voltage	$\geq 10.9 \text{ V}$
Fuel level	$9 \leftrightarrow 51 \text{ l}$ (2.38 \leftrightarrow 13.3 US gal, 1.98 \leftrightarrow 11.2 Imp gal)
Evaporation system diagnosis	Not in operation
After starting engine	80 seconds or more
Fuel tank pressure	$< -0.67 \text{ kPa}$ (-5 mmHg , -0.2 inHg) or $> -0.93 \text{ kPa}$ (7 mmHg , 0.28 inHg)

4. GENERAL DRIVING CYCLE

Perform the diagnosis continuously when the fuel tank pressure is large or small in 80 seconds or more after starting the engine.

DIAGNOSTIC TROUBLE CODE (DTC) DETECTING CRITERIA

GENERAL DESCRIPTION

5. DIAGNOSTIC METHOD

• Abnormality Judgment

Judge NG when the malfunction criteria below is completed 5 times.

• Judgment Value

Malfunction Criteria	Threshold Value
Atmospheric air change in 80 seconds	≥ 0.67 kPa (4.5 mmHg, 0.2 inHg)
Fuel tank pressure change in 80 seconds	≥ 0.67 kPa (4.5 mmHg, 0.2 inHg)
Fuel level change	$< 3 \text{ } \varnothing$ (3.2 US gal, 2.6 Imp gal)

Time Needed for Diagnosis: 80 seconds \times 5 times

Malfunction Indicator Light Illumination: Illuminates when malfunction occurs in 2 continuous driving cycles.

• Normality Judgment

Judge OK and clear NG when the malfunction criteria below is completed.

• Judgment Value

Malfunction Criteria	Threshold Value
Atmospheric air change in 80 seconds	≥ 0.67 kPa (4.5 mmHg, 0.2 inHg)
Fuel tank pressure change in 80 seconds	< 0.67 kPa (4.5 mmHg, 0.2 inHg)

6. DTC CLEAR CONDITION

- When the OK idling cycle was completed 40 times in a row
- When "Clear Memory" was performed

7. MALFUNCTION INDICATOR LIGHT CLEAR CONDITION

- When the OK driving cycle was completed 3 times in a row
- When "Clear Memory" was performed

8. FAIL SAFE

None

9. ECM OPERATION AT DTC SETTING

Memorize the freeze frame data. (For test mode \$02)

DIAGNOSTIC TROUBLE CODE (DTC) DETECTING CRITERIA

GENERAL DESCRIPTION

DI: DTC P1491 — POSITIVE CRANKCASE VENTILATION (BLOW-BY) FUNCTION PROBLEM —

1. OUTLINE OF DIAGNOSIS

Detect the blow-by hose release abnormality.
Judge NG when the diagnosis terminal voltage is high.

2. COMPONENT DESCRIPTION

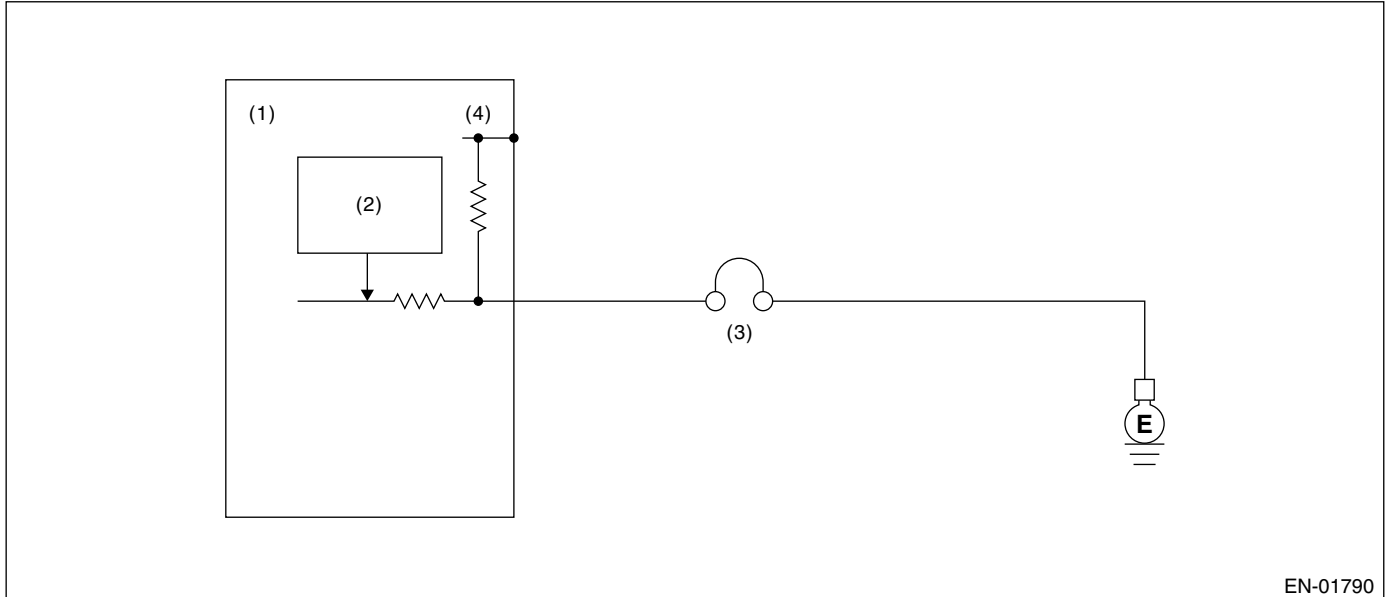

EN-01790

- (1) Engine control module (ECM)
- (2) Detecting circuit
- (3) PCV diagnosis connector
- (4) 5 V

3. ENABLE CONDITION

Secondary Parameter	Enable Condition
None	

4. GENERAL DRIVING CYCLE

Always perform the diagnosis continuously.

DIAGNOSTIC TROUBLE CODE (DTC) DETECTING CRITERIA

GENERAL DESCRIPTION

5. DIAGNOSIS METHOD

• Abnormality Judgment

Judge NG when the continuous time until completing the malfunction criteria below becomes more than 2.5 seconds.

• Judgment Value

Malfunction Criteria	Threshold Value
Battery voltage	> 10.9 V
Engine speed	≥ 500 rpm
Positive crankcase ventilation diagnosis voltage	High

Time Needed for Diagnosis: 2.5 seconds

Malfunction Indicator Light Illumination: Illuminates as soon as malfunction occurs.

• Normality Judgment

Judge OK and clear NG when the malfunction criteria below is completed.

• Judgment Value

Malfunction Criteria	Threshold Value
Battery voltage	> 10.9 V
Engine speed	≥ 500 rpm
Positive crankcase ventilation diagnosis voltage	Low

6. DTC CLEAR CONDITION

- When the OK idling cycle was completed 40 times in a row
- When "Clear Memory" was performed

7. MALFUNCTION INDICATOR LIGHT CLEAR CONDITION

- When the OK driving cycle was performed 3 times in a row
- When "Clear Memory" was performed

8. FAIL SAFE

None

9. ECM OPERATION AT DTC SETTING

Memorize the freeze frame data. (For test mode \$02)

DIAGNOSTIC TROUBLE CODE (DTC) DETECTING CRITERIA

GENERAL DESCRIPTION

DJ:DTC P1518 — STARTER SWITCH CIRCUIT LOW INPUT —

1. OUTLINE OF DIAGNOSIS

Detect the open or short circuit of starter SW.

Judge OFF NG when it turns to “after engine starting” while the starter has never been set to ON.

2. ENABLE CONDITION

Secondary Parameters	Enable Conditions
None	

3. GENERAL DRIVING CYCLE

Always perform the diagnosis continuously.

4. DIAGNOSTIC METHOD

• Abnormality Judgment

Judge OFF NG when the malfunction criteria below are completed.

• Judgment Value

Malfunction Criteria	Threshold Value
Vehicle speed	< 1 km/h (0.62 MPH)
It took more than 0.8 seconds at engine starting, and then it turned after engine starting.	
Starter ON signal	Not detected
Engine speed after the engine speed of 500 rpm or less has continued for 0.8 seconds or more	≥ 500 rpm
Battery voltage	> 8 V

Time Needed for Diagnosis: 1 second

Malfunction Indicator Light Illumination: Illuminates when malfunction occurs in 2 continuous driving cycles.

• Normality Judgment

Judge OFF OK and clear the NG when the malfunction criteria below are completed.

• Judgment Value

Malfunction Criteria	Threshold Value
Starter ON	Experienced
Starter ON diagnosis	Not diagnosis
Battery voltage	> 8 V

5. DTC CLEAR CONDITION

- When the OK idling cycle was completed 40 times in a row
- When “Clear Memory” was performed

6. MALFUNCTION INDICATOR LIGHT CLEAR CONDITION

- When the OK driving cycle was completed 3 times in a row
- When “Clear Memory” was performed

7. FAIL SAFE

None

8. ECM OPERATION AT DTC SETTING

Memorize the freeze frame data. (For test mode \$02)

DIAGNOSTIC TROUBLE CODE (DTC) DETECTING CRITERIA

GENERAL DESCRIPTION

DK:DTC P1544 — EXHAUST GAS TEMPERATURE TOO HIGH —

1. OUTLINE OF DIAGNOSIS

Detect the malfunction of high exhaust gas temperature.
Judge NG when the exhaust gas becomes too high.

2. ENABLE CONDITION

Secondary Parameters	Enable Conditions
Battery voltage	> 10.9 V

3. GENERAL DRIVING CYCLE

Always perform the diagnosis continuously.

4. DIAGNOSTIC METHOD

• Abnormality Judgment

Judge NG when the continuous time of completing the malfunction criteria below becomes more than 8.2 seconds.

• Judgment Value

Malfunction Criteria	Threshold Value
Fuel cut event	Not in operation
After fuel cut	≥ 1 milliseconds
Exhaust temperature	≥ 1050°C (1922°F)

Time Needed for Diagnosis: 8.2 seconds

Malfunction Indicator Light Illumination: Illuminates as soon as the malfunction occurs.

• Normality Judgment

Judge OK and clear the NG when the continuous time of completing the malfunction criteria below becomes more than 8.2 seconds.

• Judgment Value

Malfunction Criteria	Threshold Value
Exhaust temperature	< 550°C (1022°F)

5. DTC CLEAR CONDITION

- When the OK idling cycle was completed 40 times in a row
- When "Clear Memory" was performed

6. MALFUNCTION INDICATOR LIGHT CLEAR CONDITION

- When the OK driving cycle was completed 3 times in a row
- When "Clear Memory" was performed

7. FAIL SAFE

None

8. ECM OPERATION AT DTC SETTING

Memorize the freeze frame data. (For test mode \$02)

DIAGNOSTIC TROUBLE CODE (DTC) DETECTING CRITERIA

GENERAL DESCRIPTION

DL:DTC P1560 — BACK-UP VOLTAGE CIRCUIT MALFUNCTION —

1. OUTLINE OF DIAGNOSIS

Detect open or short circuit of the back-up voltage circuit.

Judge NG when the back-up voltage becomes smaller than the battery voltage.

2. ENABLE CONDITION

Secondary Parameter	Enable Condition
None	

3. GENERAL DRIVING CYCLE

Always perform the diagnosis continuously.

4. DIAGNOSTIC METHOD

• Abnormality Judgment

Judge NG when the continuous time of completing the malfunction criteria below becomes more than 2.5 seconds.

• Judgment Value

Malfunction Criteria	Threshold Value
Voltage of back-up power	$< \text{Battery voltage} \times 0.7$
Battery voltage	$\geq 10.9 \text{ V}$

Time Needed for Diagnosis: 2.5 seconds

Malfunction Indicator Light Illumination: Illuminates as soon as malfunction occurs.

• Normality Judgment

Judge OK and clear NG when the malfunction criteria below is completed.

• Judgment Value

Malfunction Criteria	Threshold Value
Voltage of back-up power supply	$\geq \text{Battery voltage} \times 0.7$
Battery voltage	$\geq 10.9 \text{ V}$

5. DTC CLEAR CONDITION

- When the OK idling cycle was completed 40 times in a row
- When "Clear Memory" was performed

6. MALFUNCTION INDICATOR LIGHT CLEAR CONDITION

- When the OK driving cycle was completed 3 times in a row
- When "Clear Memory" was performed

7. FAIL SAFE

None

8. ECM OPERATION AT DTC SETTING

Memorize the freeze frame data. (For test mode \$02)

DIAGNOSTIC TROUBLE CODE (DTC) DETECTING CRITERIA

GENERAL DESCRIPTION

DM:DTC P2088 — OCV SOLENOID VALVE SIGNAL A CIRCUIT OPEN (BANK 1)

1. OUTLINE OF DIAGNOSIS

Detect open or short circuit of oil flow control valve solenoid.

Judge open NG when the current flow is small whereas duty signal is large, and judge short NG when the current flow is large whereas duty signal is small.

2. ENABLE CONDITION

Secondary Parameter	Enable Condition
Battery voltage	≥ 10.9 V

3. GENERAL DRIVING CYCLE

Always perform the diagnosis continuously.

4. DIAGNOSTIC METHOD

• Abnormality Judgment

Judge NG when the continuous time of completing the malfunction criteria below becomes more than 2 seconds.

• Judgment Value

Malfunction Criteria	Threshold Value
OCV control duty	$\geq 99.61\%$
OCV control present current	< 0.306 A

Time Needed for Diagnosis: 2000 milliseconds

Malfunction Indicator Light Illumination: Illuminates as soon as malfunction occurs.

• Normality Judgment

Judge OK and clear NG when the continuous time of completing the malfunction criteria below becomes more than 2 seconds.

• Judgment Value

Malfunction Criteria	Threshold Value
Target current value of OCV	$\geq 0.14\%$
Target current value of OCV – Control current value of OCV	≥ 0.08 A

5. DTC CLEAR CONDITION

- When the OK idling cycle was completed 40 times in a row
- When “Clear Memory” was performed

6. MALFUNCTION INDICATOR LIGHT CLEAR CONDITION

- When the OK driving cycle was completed 3 times in a row
- When “Clear Memory” was performed

DIAGNOSTIC TROUBLE CODE (DTC) DETECTING CRITERIA

GENERAL DESCRIPTION

7. FAIL SAFE

- Ignition timing whole learning compensation:
 - Enter the initial value (whole learning compensation factor = 0.5, Variable amount of whole learning compensation factor = 0.25) to the whole learning compensation factor and variable amount of whole learning compensation factor when IG OFF, and then make the whole learning incomplete.
 - Enter the initial value (whole learning compensation factor = 0.5, Variable amount of whole learning compensation factor = 0.25) to the whole learning compensation factor and variable amount of whole learning compensation factor when making a normality judgment from abnormality judgment, and then make the whole learning incomplete.
- Ignition timing partial learning compensation:
 - Enter the initial value (0°CA) to the compensation value of partial learning zone when IG OFF.
 - Enter the initial value (0°CA) to the compensation value of partial learning zone when making a normality judgment from abnormality judgment.
- AVCS control:
 - Most timing retard learning is not complete or most timing retard learning completion is not experienced.
 - ISC feedback compensation: Do not perform the AVCS actual timing advance compensation.
 - Make the OCV driving Duty to be the given value (9.36%).

8. ECM OPERATION AT DTC SETTING

Memorize the freeze frame data. (For test mode \$02)

DIAGNOSTIC TROUBLE CODE (DTC) DETECTING CRITERIA

GENERAL DESCRIPTION

MEMO:

DIAGNOSTIC TROUBLE CODE (DTC) DETECTING CRITERIA

GENERAL DESCRIPTION

DN:DTC P2089 — OCV SOLENOID VALVE SIGNAL A CIRCUIT SHORT (BANK 1)

1. OUTLINE OF DIAGNOSIS

Detect open or short circuit of oil flow control valve solenoid.

Judge open NG when the current flow is small whereas duty signal is large, and judge short NG when the current flow is large whereas duty signal is small.

2. ENABLE CONDITION

Secondary Parameter	Enable Condition
Battery voltage	≥ 10.9 V

3. GENERAL DRIVING CYCLE

Always perform the diagnosis continuously.

4. DIAGNOSTIC METHOD

• Abnormality Judgment

Judge NG when the continuous time of completing the malfunction criteria below becomes more than 2 seconds.

• Judgment Value

Malfunction Criteria	Threshold Value
OCV control duty	$< 0.39\%$
OCV control present current	≥ 0.306 A

Time Needed for Diagnosis: 2000 milliseconds

Malfunction Indicator Light Illumination: Illuminates as soon as malfunction occurs.

• Normality Judgment

Judge OK and clear NG when the continuous time of completing the malfunction criteria below becomes more than 2 seconds.

• Judgment Value

Malfunction Criteria	Threshold Value
Target current value of OCV – Control current value of OCV	< 0.08 A

5. DTC CLEAR CONDITION

- When the OK idling cycle was completed 40 times in a row
- When “Clear Memory” was performed

6. MALFUNCTION INDICATOR LIGHT CLEAR CONDITION

- When the OK driving cycle was completed 3 times in a row
- When “Clear Memory” was performed

7. FAIL SAFE

- Ignition timing whole learning compensation:
 - Enter the initial value (whole learning compensation factor = 0.5, Variable amount of whole learning compensation factor = 0.25) to the whole learning compensation factor and variable amount of whole learning compensation factor when IG OFF, and then make the whole learning incomplete.
 - Enter the initial value (whole learning compensation factor = 0.5, Variable amount of whole learning compensation factor = 0.25) to the whole learning compensation factor and variable amount of whole learning compensation factor when making a normality judgment from abnormality judgment, and then make the whole learning incomplete.
- Ignition timing partial learning compensation:
 - Enter the initial value (0°CA) to the compensation value of partial learning zone when IG OFF.
 - Enter the initial value (0°CA) to the compensation value of partial learning zone when making a normality judgment from abnormality judgment.
- AVCS control:
 - Most timing retard learning is not complete or most timing retard learning completion is not experienced.
 - ISC feedback compensation: Do not perform the AVCS actual timing advance compensation.
 - Make the OCV driving Duty to be the given value (9.36%).

8. ECM OPERATION AT DTC SETTING

Memorize the freeze frame data. (For test mode \$02)

DIAGNOSTIC TROUBLE CODE (DTC) DETECTING CRITERIA

GENERAL DESCRIPTION

DO:DTC P2092 — OCV SOLENOID VALVE SIGNAL A CIRCUIT OPEN (BANK 2)

1. OUTLINE OF DIAGNOSIS

Detect open or short circuit of oil flow control valve solenoid.

Judge open NG when the current flow is small whereas duty signal is large, and judge short NG when the current flow is large whereas duty signal is small.

2. ENABLE CONDITION

Secondary Parameter	Enable Condition
Battery voltage	≥ 10.9 V

3. GENERAL DRIVING CYCLE

Always perform the diagnosis continuously.

4. DIAGNOSTIC METHOD

• Abnormality Judgment

Judge NG when the continuous time of completing the malfunction criteria below becomes more than 2 seconds.

• Judgment Value

Malfunction Criteria	Threshold Value
OCV control duty	$\geq 99.61\%$
OCV control present current	< 0.306 A

Time Needed for Diagnosis: 2000 milliseconds

Malfunction Indicator Light Illumination: Illuminates as soon as malfunction occurs.

• Normality Judgment

Judge OK and clear NG when the continuous time of completing the malfunction criteria below becomes more than 2 seconds.

• Judgment Value

Malfunction Criteria	Threshold Value
Target current value of OCV	$\geq 0.14\%$
Target current value of OCV – Control current value of OCV	≥ 0.08 A

5. DTC CLEAR CONDITION

- When the OK idling cycle was completed 40 times in a row
- When “Clear Memory” was performed

6. MALFUNCTION INDICATOR LIGHT CLEAR CONDITION

- When the OK driving cycle was completed 3 times in a row
- When “Clear Memory” was performed

DIAGNOSTIC TROUBLE CODE (DTC) DETECTING CRITERIA

GENERAL DESCRIPTION

7. FAIL SAFE

- Ignition timing whole learning compensation:
 - Enter the initial value (whole learning compensation factor = 0.5, Variable amount of whole learning compensation factor = 0.25) to the whole learning compensation factor and variable amount of whole learning compensation factor when IG OFF, and then make the whole learning incomplete.
 - Enter the initial value (whole learning compensation factor = 0.5, Variable amount of whole learning compensation factor = 0.25) to the whole learning compensation factor and variable amount of whole learning compensation factor when making a normality judgment from abnormality judgment, and then make the whole learning incomplete.
- Ignition timing partial learning compensation:
 - Enter the initial value (0°CA) to the compensation value of partial learning zone when IG OFF.
 - Enter the initial value (0°CA) to the compensation value of partial learning zone when making a normality judgment from abnormality judgment.
- AVCS control:
 - Most timing retard learning is not complete or most timing retard learning completion is not experienced.
 - ISC feedback compensation: Do not perform the AVCS actual timing advance compensation.
 - Make the OCV driving Duty to be the given value (9.36%).

8. ECM OPERATION AT DTC SETTING

Memorize the freeze frame data. (For test mode \$02)

DIAGNOSTIC TROUBLE CODE (DTC) DETECTING CRITERIA

GENERAL DESCRIPTION

DP:DTC P2093 — OCV SOLENOID VALVE SIGNAL A CIRCUIT SHORT (BANK 2)

1. OUTLINE OF DIAGNOSIS

Detect open or short circuit of oil flow control valve solenoid.

Judge open NG when the current flow is small whereas duty signal is large, and judge short NG when the current flow is large whereas duty signal is small.

2. ENABLE CONDITION

Secondary Parameter	Enable Condition
Battery voltage	≥ 10.9 V

3. GENERAL DRIVING CYCLE

Always perform the diagnosis continuously.

4. DIAGNOSTIC METHOD

• Abnormality Judgment

Judge NG when the continuous time of completing the malfunction criteria below becomes more than 2 seconds.

• Judgment Value

Malfunction Criteria	Threshold Value
OCV control duty	$< 0.39\%$
OCV control present current	≥ 0.306 A

Time Needed for Diagnosis: 2000 milliseconds

Malfunction Indicator Light Illumination: Illuminates as soon as malfunction occurs.

• Normality Judgment

Judge OK and clear NG when the continuous time of completing the malfunction criteria below becomes more than 2 seconds.

• Judgment Value

Malfunction Criteria	Threshold Value
Target current value of OCV – Control current value of OCV	< 0.08 A

5. DTC CLEAR CONDITION

- When the OK idling cycle was completed 40 times in a row
- When “Clear Memory” was performed

6. MALFUNCTION INDICATOR LIGHT CLEAR CONDITION

- When the OK driving cycle was completed 3 times in a row
- When “Clear Memory” was performed

DIAGNOSTIC TROUBLE CODE (DTC) DETECTING CRITERIA

GENERAL DESCRIPTION

7. FAIL SAFE

- Ignition timing whole learning compensation:
 - Enter the initial value (whole learning compensation factor = 0.5, Variable amount of whole learning compensation factor = 0.25) to the whole learning compensation factor and variable amount of whole learning compensation factor when IG OFF, and then make the whole learning incomplete.
 - Enter the initial value (whole learning compensation factor = 0.5, Variable amount of whole learning compensation factor = 0.25) to the whole learning compensation factor and variable amount of whole learning compensation factor when making a normality judgment from abnormality judgment, and then make the whole learning incomplete.
- Ignition timing partial learning compensation:
 - Enter the initial value (0°CA) to the compensation value of partial learning zone when IG OFF.
 - Enter the initial value (0°CA) to the compensation value of partial learning zone when making a normality judgment from abnormality judgment.
- AVCS control:
 - Most timing retard learning is not complete or most timing retard learning completion is not experienced.
 - ISC feedback compensation: Do not perform the AVCS actual timing advance compensation.
 - Make the OCV driving Duty to be the given value (9.36%).

8. ECM OPERATION AT DTC SETTING

Memorize the freeze frame data. (For test mode \$02)

DIAGNOSTIC TROUBLE CODE (DTC) DETECTING CRITERIA

GENERAL DESCRIPTION

DQ:DTC P2096 — POST CATALYST FUEL TRIM SYSTEM TOO LEAN BANK 1 —

1. OUTLINE OF DIAGNOSIS

Detect the malfunction of fuel system from the amount of sub feedback control.

Sub feedback control amount sticks to lean sides during sub feedback control.

Judge NG when the rear oxygen sensor output does not come close to target voltage (slice level).

2. COMPONENT DESCRIPTION

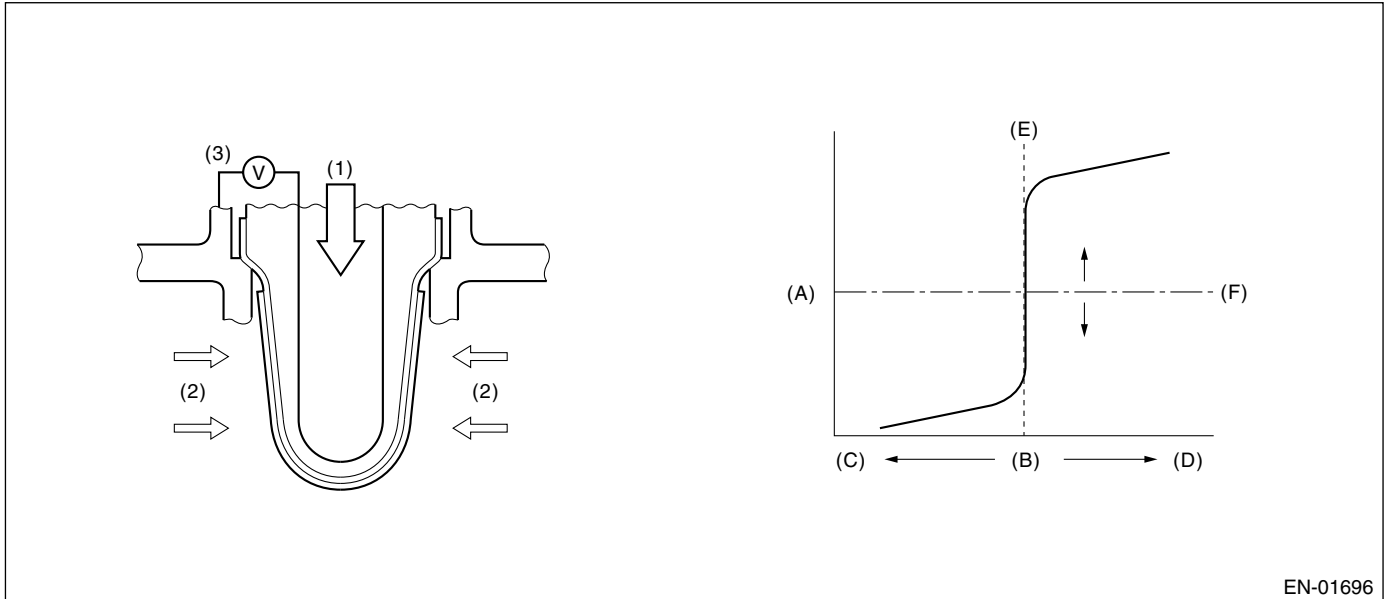

EN-01696

- (1) Atmosphere
- (2) Exhaust gas
- (3) Electromotive force

- (A) Electromotive force
- (B) Air fuel ratio
- (C) Rich

- (D) Lean
- (E) Theoretical air fuel ratio
- (F) Comparative voltage

3. ENABLE CONDITION

Secondary Parameters	Enable Conditions
Main feedback	In operation
Sub feedback	In operation
Amount of intake air	$\geq 15 \text{ g (0.53 oz)/sec}$
Sub feedback	Sticks to the limit value (lean side)

4. GENERAL DRIVING CYCLE

Perform the diagnosis continuously at a constant 80 km/h (50 MPH) or more.

DIAGNOSTIC TROUBLE CODE (DTC) DETECTING CRITERIA

GENERAL DESCRIPTION

5. DIAGNOSTIC METHOD

• Abnormality Judgment

Calculate the continuous time from the sticking of sub feedback control amount to lean side and cumulative deviation (sumdelo2) of rear oxygen sensor voltage and target voltage.

Judge NG when the malfunction criteria below are completed after 300 seconds have passed continuously.

• Judgment Value

Malfunction Criteria	Threshold Value
sumdelo2 = sumdelo2 + (rvo2 - rsl) rvo2 = sensing voltage of O ₂ sensor rsl = target voltage of O ₂ sensor	< -2500 V

Time Needed for Diagnosis: 300 seconds

Malfunction Indicator Light Illumination: Illuminates when malfunction occurs in 2 continuous driving cycles.

• Normality Judgment

Judge OK and clear the NG when the rear oxygen output is reversed, and during 4 seconds after that, the sub feedback control amount does not stick to rich or lean sides.

6. DTC CLEAR CONDITION

- When the OK idling cycle was completed 40 times in a row
- When "Clear Memory" was performed

7. MALFUNCTION INDICATOR LIGHT CLEAR CONDITION

- When OK with similar drive in 3 drive cycles
- When "Clear Memory" was performed

8. FAIL SAFE

None

9. ECM OPERATION AT DTC SETTING

Memorize the freeze frame data. (For test mode \$02)

DIAGNOSTIC TROUBLE CODE (DTC) DETECTING CRITERIA

GENERAL DESCRIPTION

DR:DTC P2097 — POST CATALYST FUEL TRIM SYSTEM TOO RICH BANK 1 —

1. OUTLINE OF DIAGNOSIS

Detect the malfunction of fuel system from the amount of sub feedback control.

Sub feedback control amount sticks to rich sides during sub feedback control.

Judge NG when the rear oxygen sensor output does not come close to target voltage (slice level).

2. COMPONENT DESCRIPTION

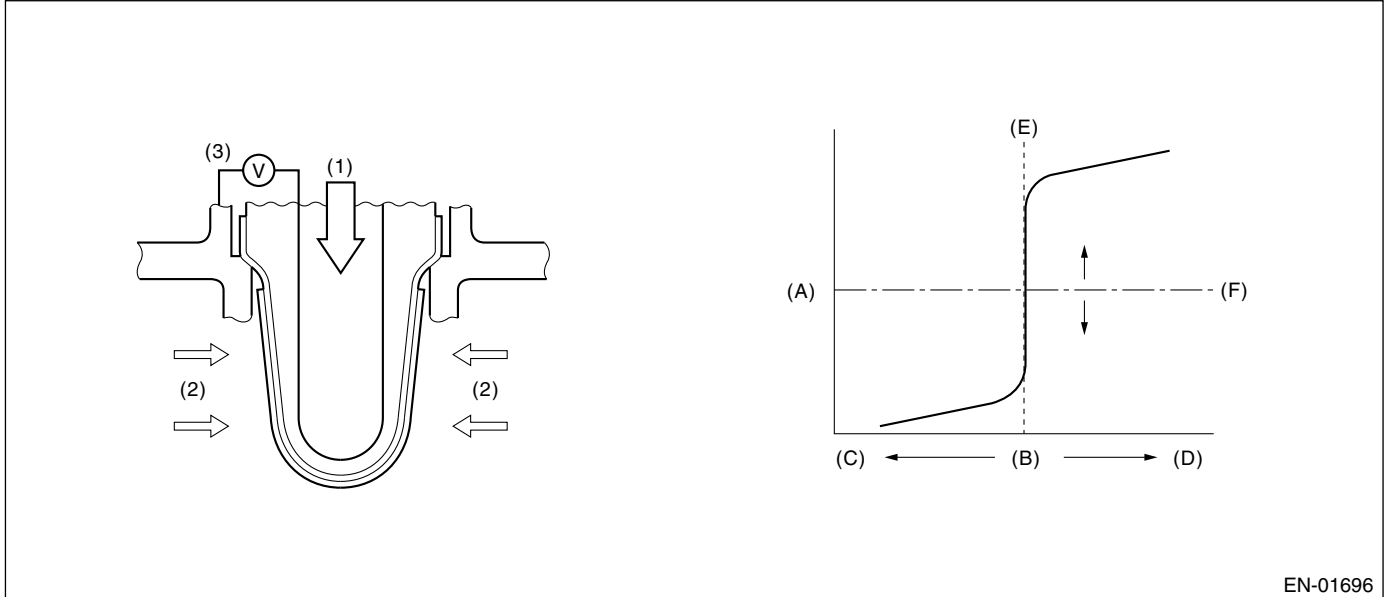

EN-01696

- (1) Atmosphere
- (2) Exhaust gas
- (3) Electromotive force

- (A) Electromotive force
- (B) Air fuel ratio
- (C) Rich

- (D) Lean
- (E) Theoretical air fuel ratio
- (F) Comparative voltage

3. ENABLE CONDITION

Secondary Parameters	Enable Conditions
Main feedback	In operation
Sub feedback	In operation
Amount of intake air	$\geq 15 \text{ g (0.53 oz)/sec}$
Sub feedback	Sticks to the limit value (rich side)

4. GENERAL DRIVING CYCLE

Perform the diagnosis continuously at a constant 80 km/h (50 MPH) or more.

DIAGNOSTIC TROUBLE CODE (DTC) DETECTING CRITERIA

GENERAL DESCRIPTION

5. DIAGNOSTIC METHOD

• Abnormality Judgment

Calculate the continuous time from the sticking of sub feedback control amount to rich side and cumulative deviation (sumdelo2) of rear oxygen sensor voltage and target voltage.

Judge NG when the malfunction criteria below are completed after 300 seconds have passed continuously.

• Judgment Value

Malfunction Criteria	Threshold Value
sumdelo2 = sumdelo2 + (rvo2 - rsl) rvo2 = sensing voltage of O ₂ sensor rsl = target voltage of O ₂ sensor	> 1500 V

Time Needed for Diagnosis: 300 seconds

Malfunction Indicator Light Illumination: Illuminates when malfunction occurs in 2 continuous drive cycles.

• Normality Judgment

Judge OK and clear the NG when the rear oxygen output is reversed, and during 4 seconds after that, the sub feedback control amount does not stick to rich or lean sides.

6. DTC CLEAR CONDITION

- When the OK idling cycle was completed 40 times in a row
- When "Clear Memory" was performed

7. MALFUNCTION INDICATOR LIGHT CLEAR CONDITION

- When OK with similar drive in 3 drive cycles.
- When "Clear Memory" was performed

8. FAIL SAFE

None

9. ECM OPERATION AT DTC SETTING

Memorize the freeze frame data. (For test mode \$02)

DIAGNOSTIC TROUBLE CODE (DTC) DETECTING CRITERIA

GENERAL DESCRIPTION

5. DIAGNOSTIC METHOD

• Abnormality Judgment

Judge OK and clear the NG when the malfunction criteria below are completed.

• Judgment Value

Malfunction Criteria	Threshold Value
Motor current	≤ 8 A
Drive circuit inner temperature	$\leq 175^{\circ}\text{C}$ (347°F)

Time Needed for Diagnosis:

- 500 milliseconds (NG judgment)
- 2000 milliseconds (OK judgment)

Malfunction Indicator Light Illumination: Illuminates as soon as malfunction occurs.

6. DTC CLEAR CONDITION

- When the OK idling cycle was completed 40 times in a row
- When "Clear Memory" was performed (Only engine stop)

7. MALFUNCTION INDICATOR LIGHT CLEAR CONDITION

- When the OK driving cycle was completed 3 times in a row
- When "Clear Memory" was performed (Only engine stop)

8. FAIL SAFE

Stop the continuity to the electronic control throttle motor. (Fix the throttle opening angle to 6° .)

9. ECM OPERATION AT DTC SETTING

Memorize the freeze frame data. (For test mode \$02)

DIAGNOSTIC TROUBLE CODE (DTC) DETECTING CRITERIA

GENERAL DESCRIPTION

DT:DTC P2102 — THROTTLE ACTUATOR CONTROL MOTOR CIRCUIT LOW —

1. OUTLINE OF DIAGNOSIS

Judge NG when the electronic control throttle power is not supplied even when ECM sets the electric control throttle relay to ON.

2. COMPONENT DESCRIPTION

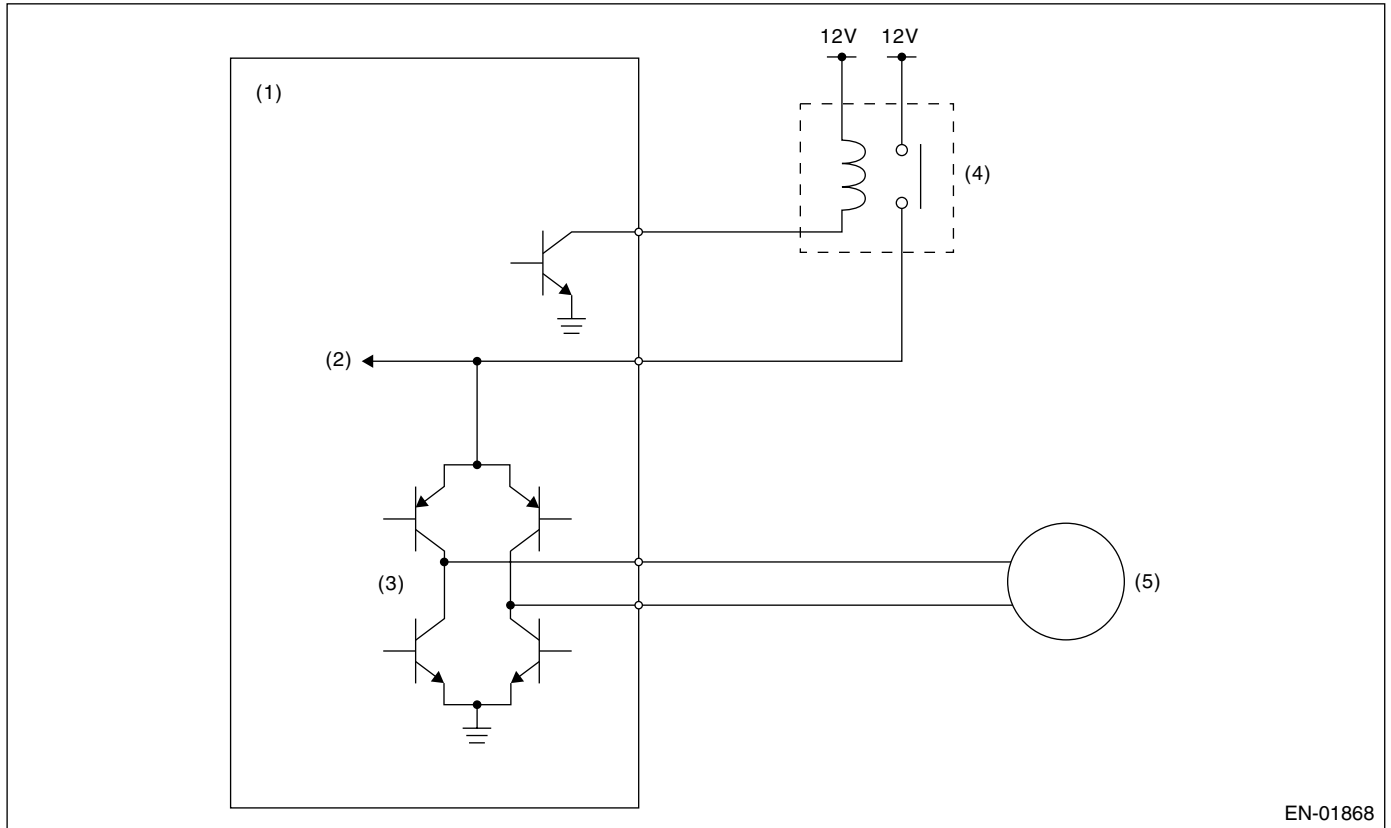

(1) Engine control module (ECM)

(3) Drive circuit

(5) Motor

(2) Voltage detection circuit

(4) Electronic control throttle relay

3. ENABLE CONDITION

Secondary Parameters	Enable Conditions
Electronic control throttle relay output	ON

4. GENERAL DRIVING CYCLE

Always perform the diagnosis continuously.

DIAGNOSTIC TROUBLE CODE (DTC) DETECTING CRITERIA

GENERAL DESCRIPTION

5. DIAGNOSTIC METHOD

• Abnormality Judgment

Judge NG when continuous time of completing the malfunction criteria below becomes more than 0.5 seconds.

• Judgment Value

Malfunction Criteria	Threshold Value
Motor power voltage	$\geq 5 \text{ V}$

Time Needed for Diagnosis:

- 400 milliseconds (For NG)
- 2000 milliseconds (For OK)

Malfunction Indicator Light Illumination: Illuminates as soon as malfunction occurs.

6. DTC CLEAR CONDITION

- When the OK idling cycle was completed 40 times in a row
- When "Clear Memory" was performed (Only engine stop)

7. MALFUNCTION INDICATOR LIGHT CLEAR CONDITION

- When the OK driving cycle was completed 3 times in a row
- When "Clear Memory" was performed (Only engine stop)

8. FAIL SAFE

Stop the continuity to the electronic control throttle motor. (Fix the throttle opening angle to 6°.)

9. ECM OPERATION AT DTC SETTING

Memorize the freeze frame data. (For test mode \$02)

DIAGNOSTIC TROUBLE CODE (DTC) DETECTING CRITERIA

GENERAL DESCRIPTION

DU:DTC P2103 — THROTTLE ACTUATOR CONTROL MOTOR CIRCUIT HIGH —

1. OUTLINE OF DIAGNOSIS

Judge NG when the power for electronic throttle control system is not supplied even when ECM sets the electric throttle control relay to OFF.

2. COMPONENT DESCRIPTION

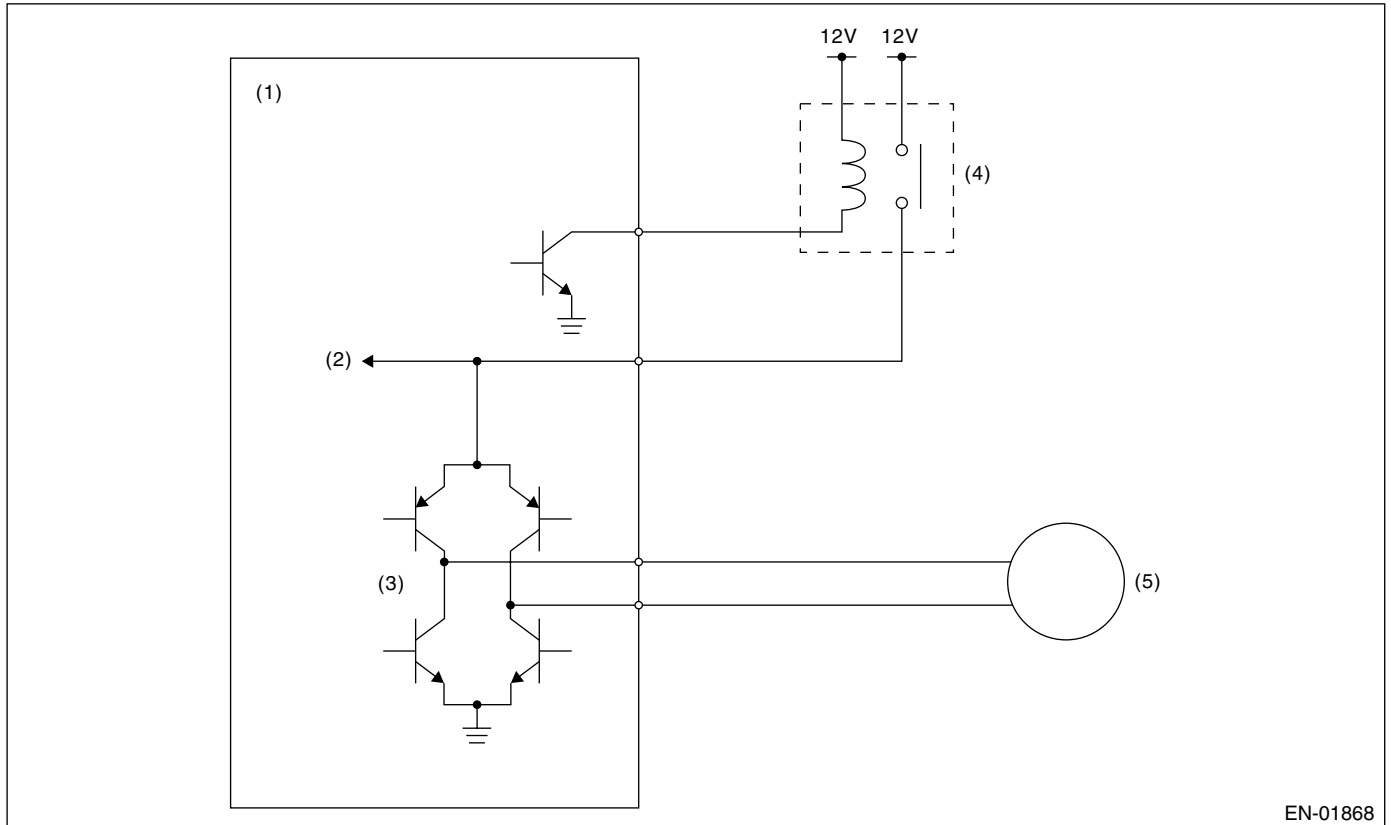

EN-01868

- (1) Engine control module (ECM) (3) Drive circuit (5) Motor
 (2) Voltage detection circuit (4) Electronic throttle control relay

3. ENABLE CONDITION

Secondary Parameters	Enable Conditions
Electronic throttle control relay output	OFF

4. GENERAL DRIVING CYCLE

- Ignition switch ON → OFF
- Ignition switch OFF → ON (After clear memory only)

5. DIAGNOSTIC METHOD

Judge OK and clear the NG when the malfunction criteria below are completed.

Judgment Value

Malfunction Criteria	Threshold Value
Motor power voltage	≤ 5 V

Time Needed for Diagnosis:

- 600 milliseconds (For NG)
- 400 milliseconds (For OK)

Malfunction Indicator Light Illumination: Illuminates as soon as malfunction occurs.

DIAGNOSTIC TROUBLE CODE (DTC) DETECTING CRITERIA

GENERAL DESCRIPTION

6. DTC CLEAR CONDITION

- When the OK idling cycle was completed 40 times in a row
- When "Clear Memory" was performed (Only engine stop)

7. MALFUNCTION INDICATOR LIGHT CLEAR CONDITION

- When the OK driving cycle was completed 3 times in a row
- When "Clear Memory" was performed (Only engine stop)

8. FAIL SAFE

Stop the continuity to the electronic control throttle motor. (Fix the throttle opening angle to 6°.)

9. ECM OPERATION AT DTC SETTING

Memorize the freeze frame data. (For test mode \$02)

DIAGNOSTIC TROUBLE CODE (DTC) DETECTING CRITERIA

GENERAL DESCRIPTION

DV:DTC P2109 — THROTTLE/PEDAL POSITION SENSOR A MINIMUM STOP PERFORMANCE —

1. OUTLINE OF DIAGNOSIS

Judge NG when all close point learning cannot be conducted or an abnormal value is detected.

2. COMPONENT DESCRIPTION

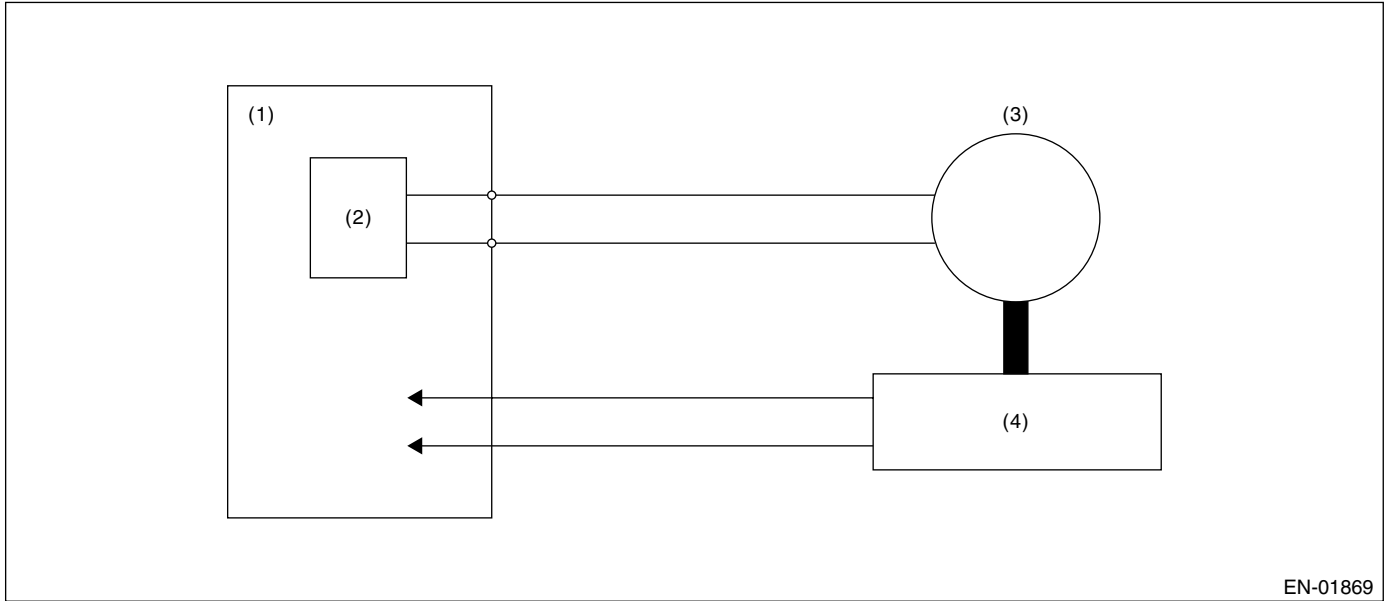

EN-01869

- (1) Engine control module (ECM)
- (2) Drive circuit
- (3) Motor
- (4) Throttle position sensor

3. ENABLE CONDITION

Secondary Parameters	Enable Conditions
Ignition switch	ON → OFF
Ignition switch (after clear memory only)	OFF → ON

4. GENERAL DRIVING CYCLE

Perform the diagnosis at all close point learning.

5. DIAGNOSTIC METHOD

• Abnormality Judgment

Judge OK and clear the NG when the malfunction criteria below are completed.

• Judgment Value

Malfunction Criteria	Threshold Value
Throttle sensor voltage at all close point learning	0.41 — 0.79 V
Time for all close point learning completion	Within 80 milliseconds

Time Needed for Diagnosis: None

Malfunction Indicator Light Illumination: Illuminates as soon as malfunction occurs.

6. DTC CLEAR CONDITION

- When the OK idling cycle was completed 40 times in a row
- When "Clear Memory" was performed (Only engine stop)

DIAGNOSTIC TROUBLE CODE (DTC) DETECTING CRITERIA

GENERAL DESCRIPTION

7. MALFUNCTION INDICATOR LIGHT CLEAR CONDITION

- When the OK driving cycle was completed 3 times in a row
- When "Clear Memory" was performed (Only engine stop)

8. FAIL SAFE

Stop the continuity to the electronic control throttle motor. (Fix the throttle opening angle to 6°.)

9. ECM OPERATION AT DTC SETTING

Memorize the freeze frame data. (For test mode \$02)

DIAGNOSTIC TROUBLE CODE (DTC) DETECTING CRITERIA

GENERAL DESCRIPTION

DW:DTC P2122 — THROTTLE/PEDAL POSITION SENSOR/SWITCH “D” CIRCUIT LOW INPUT —

1. OUTLINE OF DIAGNOSIS

Detect the open or short circuit of accelerator pedal position sensor 1.
Judge NG when out of the standard value.

2. COMPONENT DESCRIPTION

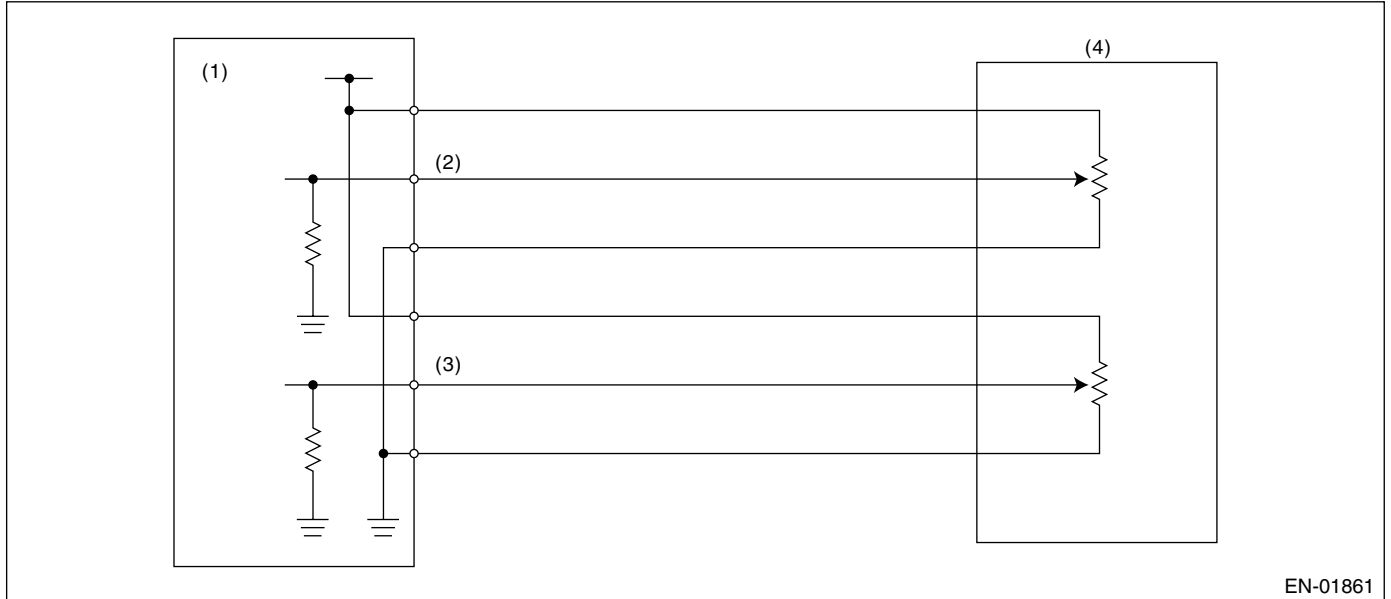

- (1) Engine control module (ECM)
- (2) Accelerator pedal position sensor 1 signal.
- (3) Accelerator pedal position sensor 2 signal.
- (4) Accelerator pedal position sensor

3. ENABLE CONDITION

Secondary Parameters	Enable Conditions
Ignition switch	ON

4. GENERAL DRIVING CYCLE

Always perform the diagnosis continuously.

5. DIAGNOSTIC METHOD

Judge OK and clear the NG when the malfunction criteria below are completed.

Judgment Value

Malfunction Criteria	Threshold Value
Sensor 1 input voltage	≥ 0.308 V

Time Needed for Diagnosis: 100 milliseconds

Malfunction Indicator Light Illumination: Illuminates as soon as malfunction occurs.

6. DTC CLEAR CONDITION

- When the OK idling cycle was completed 40 times in a row
- When “Clear Memory” was performed (Only engine stop)

7. MALFUNCTION INDICATOR LIGHT CLEAR CONDITION

- When the OK driving cycle was completed 3 times in a row
- When “Clear Memory” was performed (Only engine stop)

DIAGNOSTIC TROUBLE CODE (DTC) DETECTING CRITERIA

GENERAL DESCRIPTION

8. FAIL SAFE

- Single malfunction: Control with normal sensor
- Multi malfunction: Fix the throttle opening angle to 6°.

9. ECM OPERATION AT DTC SETTING

Memorize the freeze frame data. (For test mode \$02)

DIAGNOSTIC TROUBLE CODE (DTC) DETECTING CRITERIA

GENERAL DESCRIPTION

DX:DTC P2123 — THROTTLE/PEDAL POSITION SENSOR/SWITCH “D” CIRCUIT HIGH INPUT —

1. OUTLINE OF DIAGNOSIS

Detect the open or short circuit of accelerator pedal position sensor 1.
Judge NG when out of the standard value.

2. COMPONENT DESCRIPTION

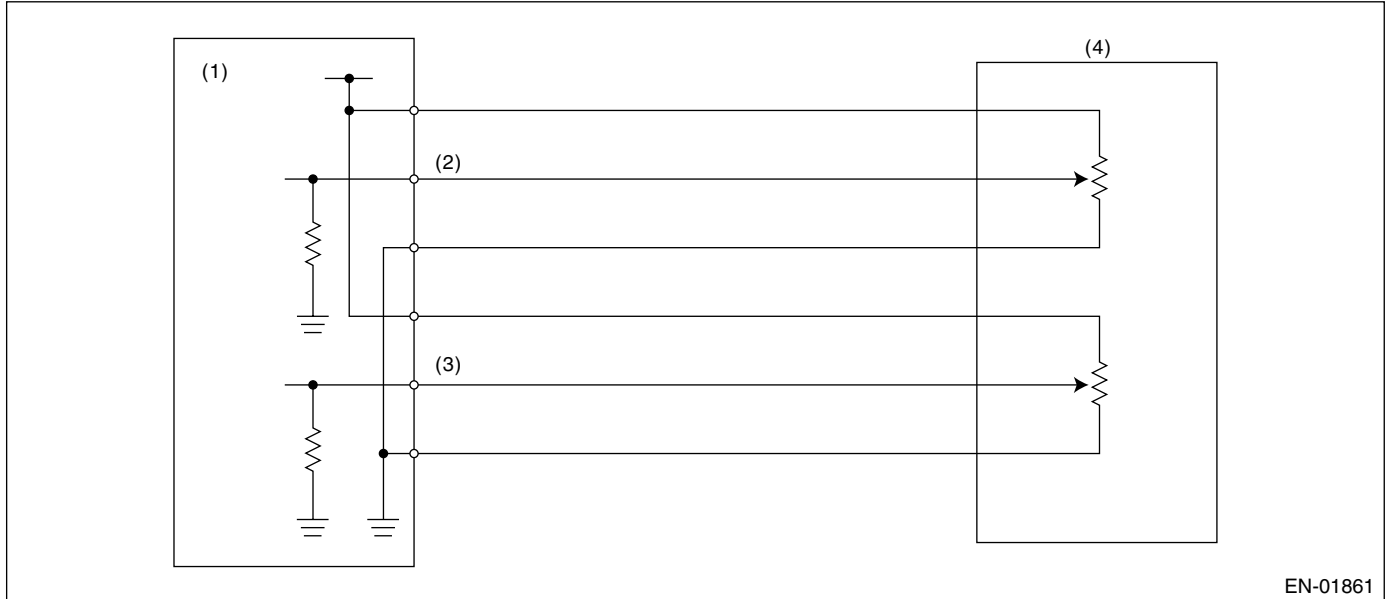

- (1) Engine control module (ECM)
- (2) Accelerator pedal position sensor 1 signal.
- (3) Accelerator pedal position sensor 2 signal.
- (4) Accelerator pedal position sensor

3. ENABLE CONDITION

Secondary Parameters	Enable Conditions
Ignition switch	ON

4. GENERAL DRIVING CYCLE

Always perform the diagnosis continuously.

5. DIAGNOSTIC METHOD

Judge OK and clear the NG when the malfunction criteria below are completed.

Judgment Value

Malfunction Criteria	Threshold Value
Sensor 1 input voltage	≤ 4.856 V

Time Needed for Diagnosis: 100 milliseconds

Malfunction Indicator Light Illumination: Illuminates as soon as malfunction occurs.

6. DTC CLEAR CONDITION

- When the OK idling cycle was completed 40 times in a row
- When “Clear Memory” was performed (Only engine stop)

7. MALFUNCTION INDICATOR LIGHT CLEAR CONDITION

- When the OK driving cycle was completed 3 times in a row
- When “Clear Memory” was performed (Only engine stop)

DIAGNOSTIC TROUBLE CODE (DTC) DETECTING CRITERIA

GENERAL DESCRIPTION

8. FAIL SAFE

- Single malfunction: Control with normal sensor
- Multi malfunction: Fix the throttle opening angle to 6°.

9. ECM OPERATION AT DTC SETTING

Memorize the freeze frame data. (For test mode \$02)

DIAGNOSTIC TROUBLE CODE (DTC) DETECTING CRITERIA

GENERAL DESCRIPTION

DY:DTC P2127 — THROTTLE/PEDAL POSITION SENSOR/SWITCH “E” CIRCUIT LOW INPUT —

1. OUTLINE OF DIAGNOSIS

Detect the open or short circuit of accelerator pedal position sensor 2. Judge NG when out of the standard value.

2. COMPONENT DESCRIPTION

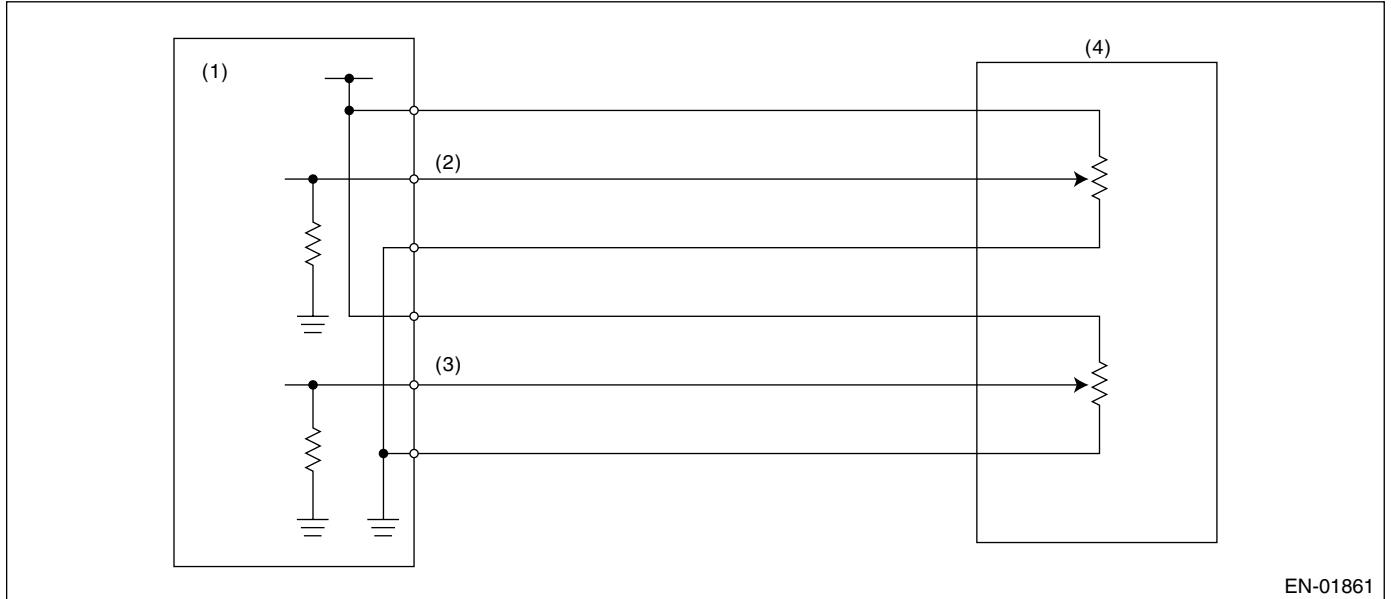

EN-01861

- | | |
|---|---|
| (1) Engine control module (ECM) | (3) Accelerator pedal position sensor 2 signal. |
| (2) Accelerator pedal position sensor 1 signal. | (4) Accelerator pedal position sensor |

3. ENABLE CONDITION

Secondary Parameters	Enable Conditions
Ignition switch	ON

4. GENERAL DRIVING CYCLE

Always perform the diagnosis continuously.

5. DIAGNOSTIC METHOD

Judge OK and clear the NG when the malfunction criteria below are completed.

Judgment Value

Malfunction Criteria	Threshold Value
Sensor 1 input voltage	≥ 0.308 V

Time Needed for Diagnosis: 100 milliseconds

Malfunction Indicator Light Illumination: Illuminates as soon as malfunction occurs.

6. DTC CLEAR CONDITION

- When the OK idling cycle was completed 40 times in a row
- When “Clear Memory” was performed (Only engine stop)

7. MALFUNCTION INDICATOR LIGHT CLEAR CONDITION

- When the OK driving cycle was completed 3 times in a row
- When “Clear Memory” was performed (Only engine stop)

DIAGNOSTIC TROUBLE CODE (DTC) DETECTING CRITERIA

GENERAL DESCRIPTION

8. FAIL SAFE

- Single malfunction: Control with normal sensor
- Multi malfunction: Fix the throttle opening angle to 6°.

9. ECM OPERATION AT DTC SETTING

Memorize the freeze frame data. (For test mode \$02)

DIAGNOSTIC TROUBLE CODE (DTC) DETECTING CRITERIA

GENERAL DESCRIPTION

DZ:DTC P2128 — THROTTLE/PEDAL POSITION SENSOR/SWITCH “E” CIRCUIT HIGH INPUT —

1. OUTLINE OF DIAGNOSIS

Detect the open or short circuit of accelerator pedal position sensor 2. Judge NG when out of the standard value.

2. COMPONENT DESCRIPTION

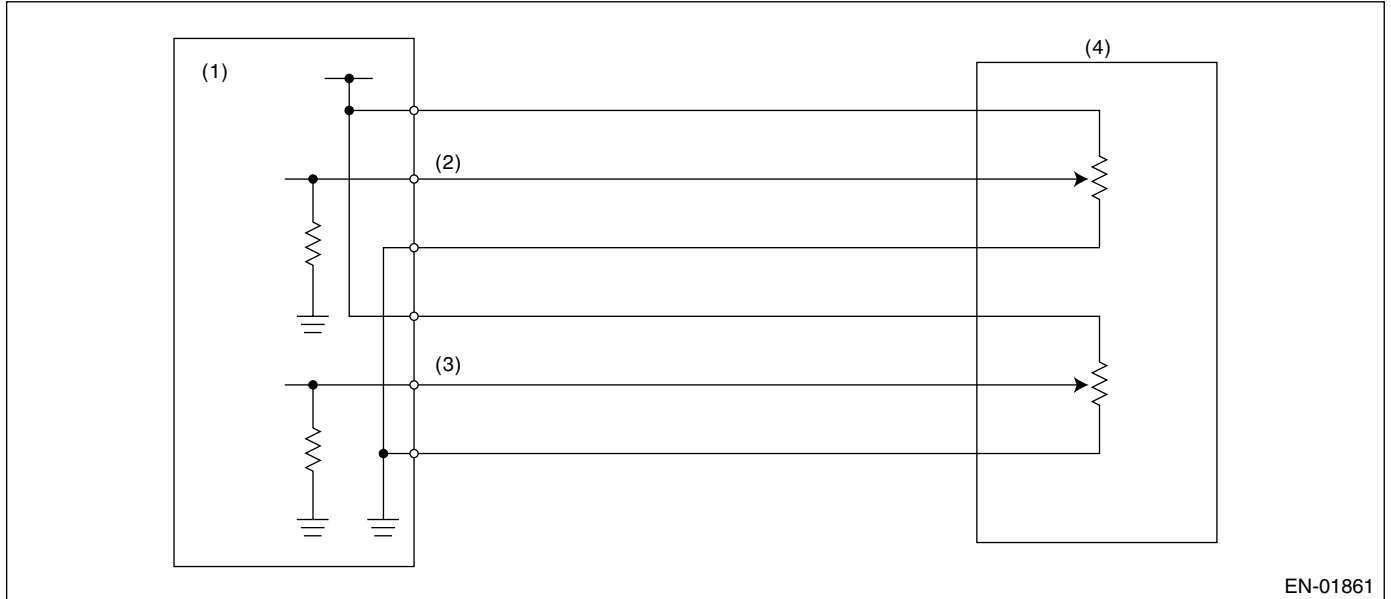

EN-01861

- | | |
|---|---|
| (1) Engine control module (ECM) | (3) Accelerator pedal position sensor 2 signal. |
| (2) Accelerator pedal position sensor 1 signal. | (4) Accelerator pedal position sensor |

3. ENABLE CONDITION

Secondary Parameters	Enable Conditions
Ignition switch	ON

4. GENERAL DRIVING CYCLE

Always perform the diagnosis continuously.

5. DIAGNOSTIC METHOD

Judge OK and clear the NG when the malfunction criteria below are completed.

Judgment Value

Malfunction Criteria	Threshold Value
Sensor 1 input voltage	≥ 0.308 V

Time Needed for Diagnosis: 100 milliseconds

Malfunction Indicator Light Illumination: Illuminates as soon as malfunction occurs.

6. DTC CLEAR CONDITION

- When the OK idling cycle was completed 40 times in a row
- When “Clear Memory” was performed (Only engine stop)

7. MALFUNCTION INDICATOR LIGHT CLEAR CONDITION

- When the OK driving cycle was completed 3 times in a row
- When “Clear Memory” was performed (Only engine stop)

DIAGNOSTIC TROUBLE CODE (DTC) DETECTING CRITERIA

GENERAL DESCRIPTION

8. FAIL SAFE

- Single malfunction: Control with normal sensor
- Multi malfunction: Fix the throttle opening angle to 6°.

9. ECM OPERATION AT DTC SETTING

Memorize the freeze frame data. (For test mode \$02)

DIAGNOSTIC TROUBLE CODE (DTC) DETECTING CRITERIA

GENERAL DESCRIPTION

EA:DTC P2135 — THROTTLE/PEDAL POSITION SENSOR/SWITCH “A” / “B” VOLTAGE RATIONALITY —

1. OUTLINE OF DIAGNOSIS

Judge NG when the signal level of throttle position sensor 1 is different from the throttle position sensor 2.

2. COMPONENT DESCRIPTION

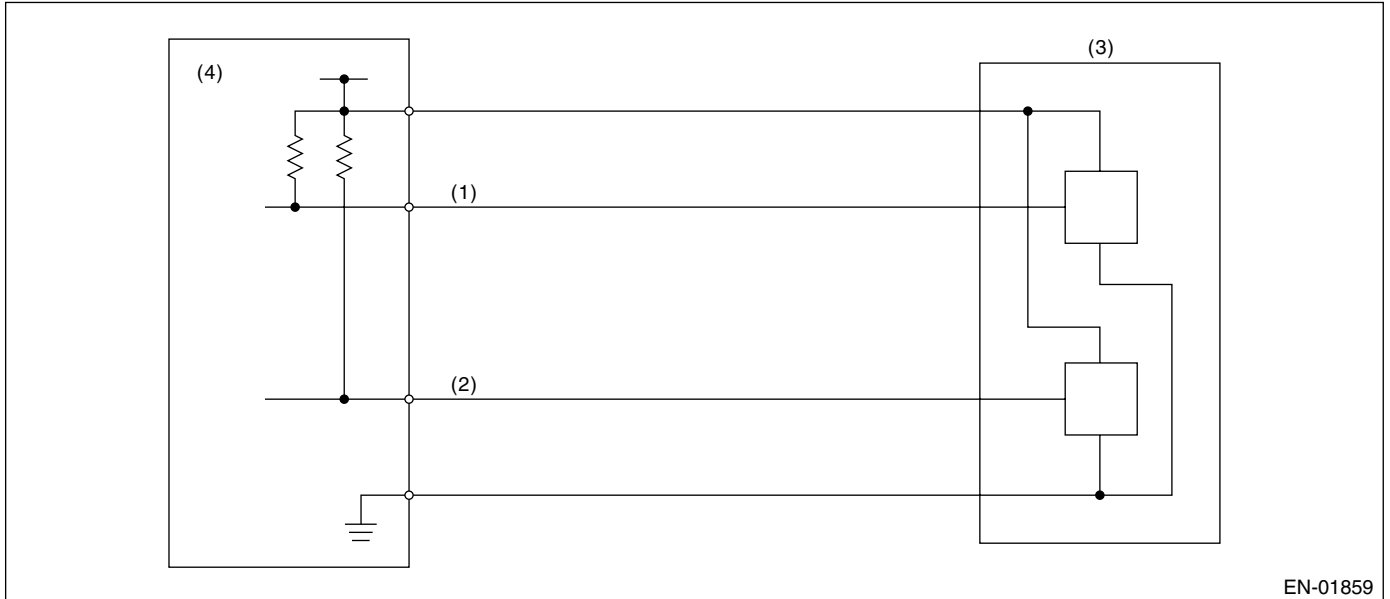

EN-01859

- (1) Throttle position sensor 1 signal. (3) Throttle position sensor
(2) Throttle position sensor 2 signal. (4) Engine control module (ECM)

3. ENABLE CONDITION

Secondary Parameters	Enable Conditions
Ignition switch	ON

4. GENERAL DRIVING CYCLE

Always perform the diagnosis continuously.

5. DIAGNOSTIC METHOD

Judge OK and clear the NG when the malfunction criteria below are completed.

Judgment Value

Malfunction Criteria	Threshold Value
Signal difference between two sensors	≤ 4.25

DIAGNOSTIC TROUBLE CODE (DTC) DETECTING CRITERIA

GENERAL DESCRIPTION

Details of Judgment Value

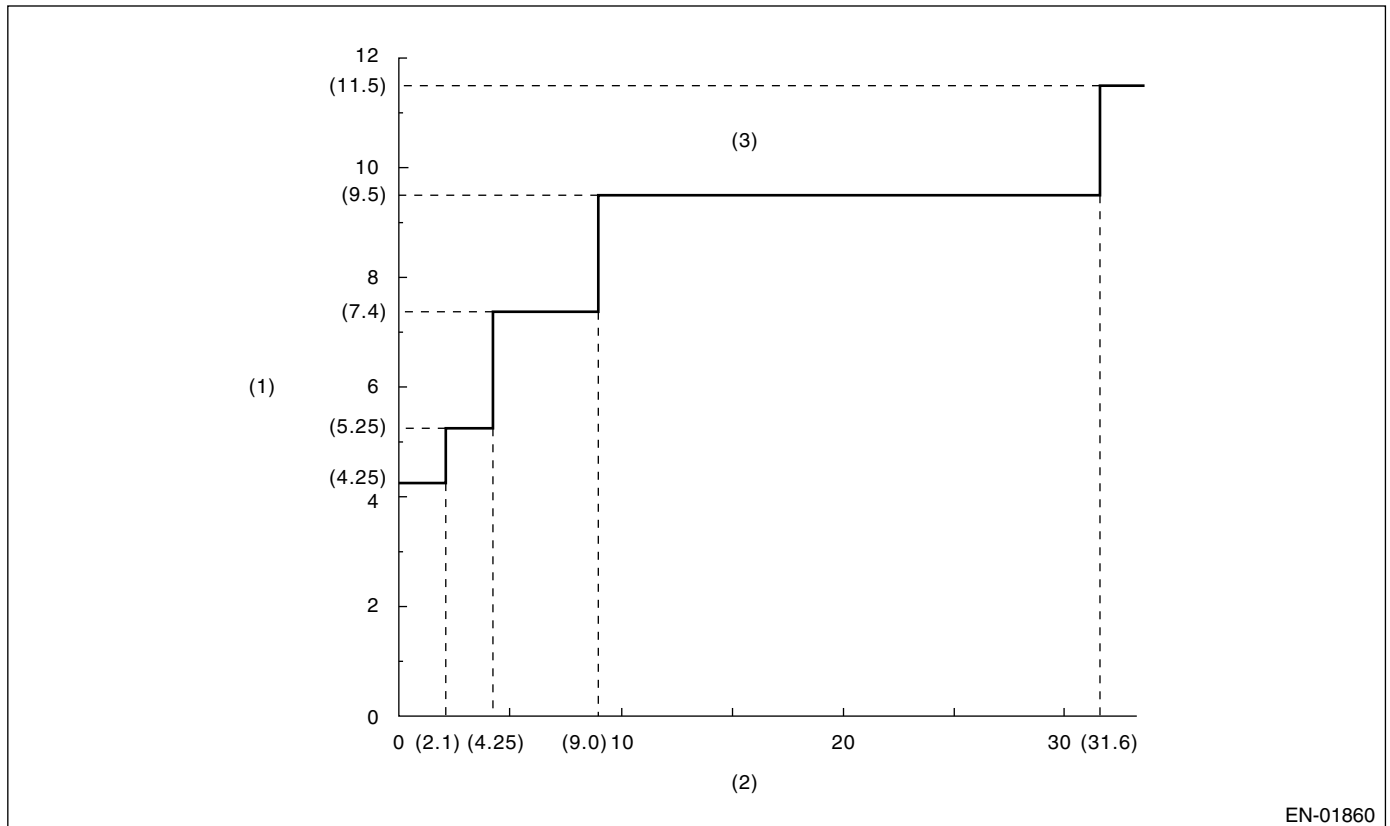

EN-01860

(1) Sensor output difference (°)

(2) Throttle position sensor 1 opening angle (°)

(3) NG area

Time Needed for Diagnosis: 212 milliseconds

Malfunction Indicator Light Illumination: Illuminates as soon as malfunction occurs.

6. DTC CLEAR CONDITION

- When the OK idling cycle was completed 40 times in a row
- When "Clear Memory" was performed (Only engine stop)

7. MALFUNCTION INDICATOR LIGHT CLEAR CONDITION

- When the OK driving cycle was completed 3 times in a row
- When "Clear Memory" was performed (Only engine stop)

8. FAIL SAFE

Stop the continuity to ETC motor. (Fix the throttle opening angle to 6°.)

9. ECM OPERATION AT DTC SETTING

Memorize the freeze frame data. (For test mode \$02)

DIAGNOSTIC TROUBLE CODE (DTC) DETECTING CRITERIA

GENERAL DESCRIPTION

EB:DTC P2138 — THROTTLE/PEDAL POSITION SENSOR/SWITCH “D” / “E” VOLTAGE RATIONALITY —

1. OUTLINE OF DIAGNOSIS

Judge NG when the signal level of throttle position sensor 1 is different from the throttle position sensor 2.

2. COMPONENT DESCRIPTION

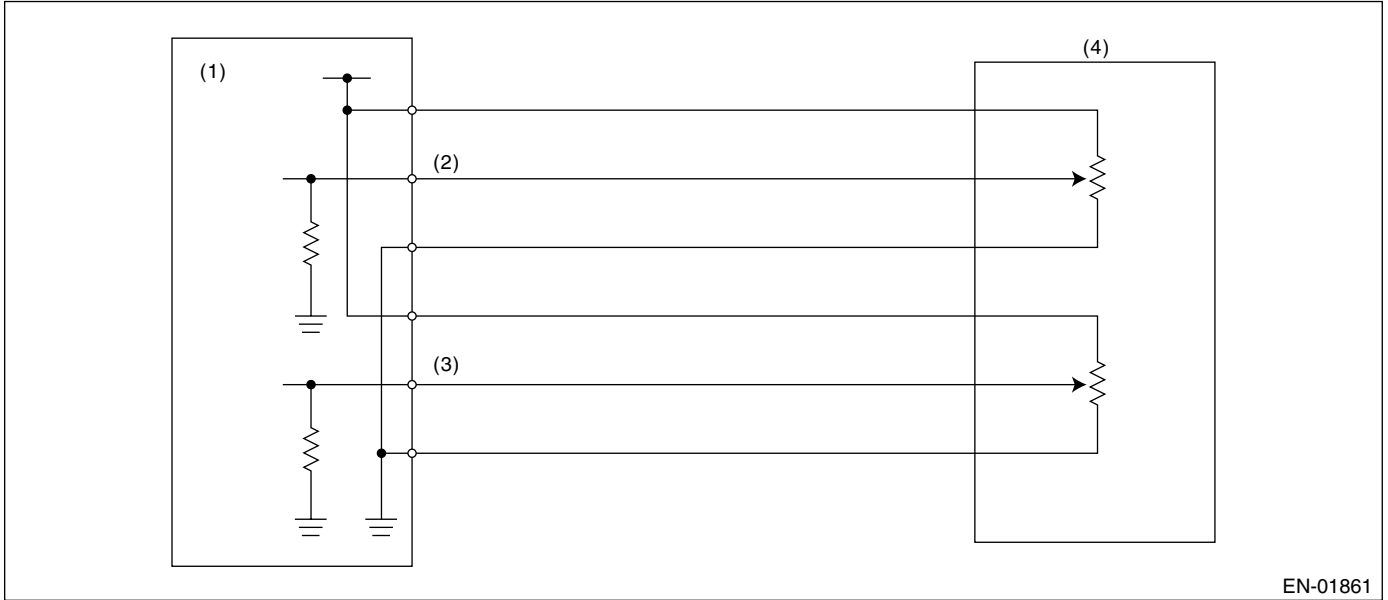

EN-01861

- (1) Engine control module (ECM)
(2) Accelerator pedal position sensor 1 signal.
(3) Accelerator pedal position sensor 2 signal.
(4) Accelerator pedal position sensor

3. ENABLE CONDITION

Secondary Parameters	Enable Conditions
Ignition switch	ON

4. GENERAL DRIVING CYCLE

Always perform the diagnosis continuously.

5. DIAGNOSTIC METHOD

Judge NG when the continuous time of completing the malfunction criteria below becomes more than 0.5 seconds.

Judgment Value

Malfunction Criteria	Threshold Value
Signal difference between two sensors	$\leq 0.8^\circ$

DIAGNOSTIC TROUBLE CODE (DTC) DETECTING CRITERIA

GENERAL DESCRIPTION

Details of Judgment Value

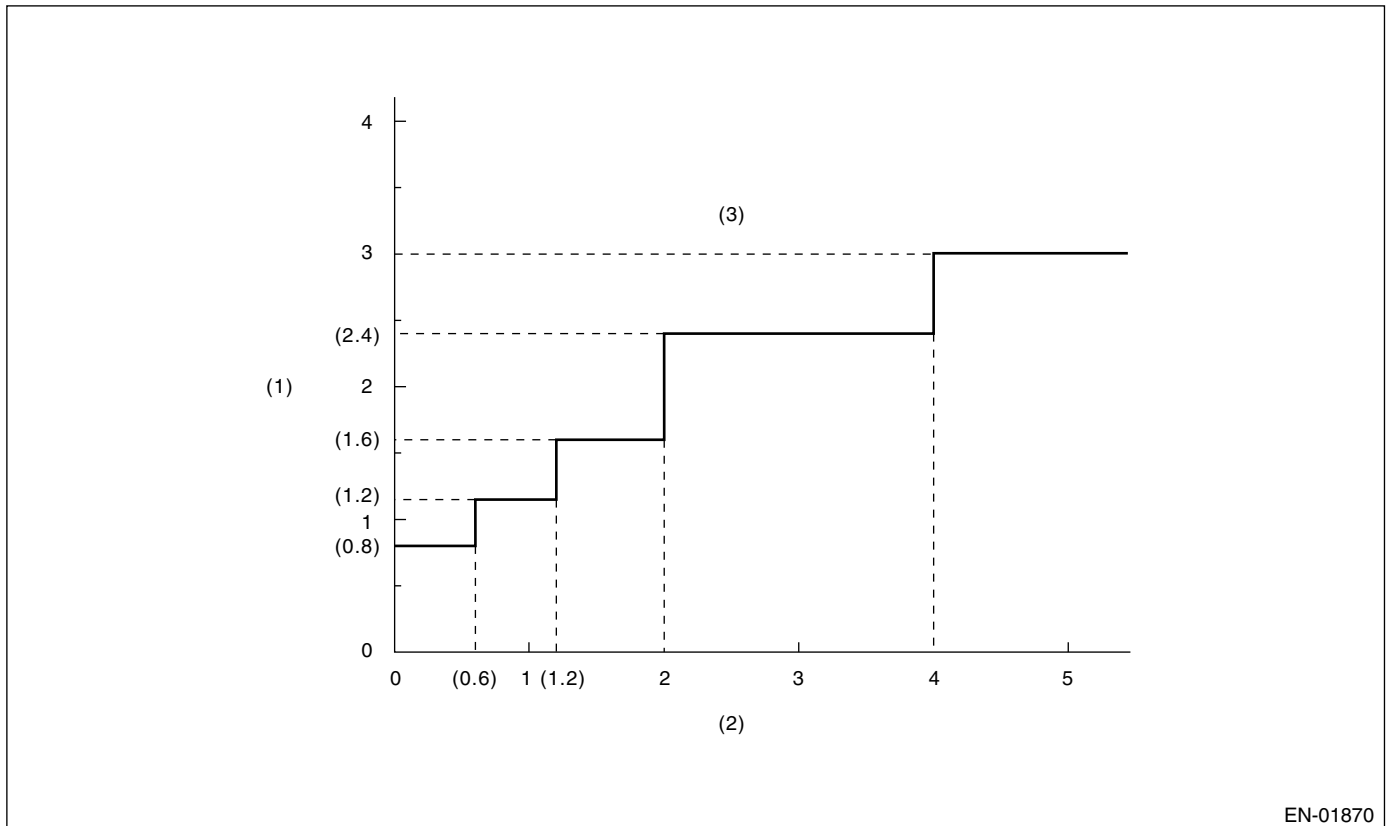

EN-01870

(1) Sensor output difference (°)

(2) Accelerator pedal position sensor
2 opening angle (°)

(3) NG area

Time Needed for Diagnosis:

- 116 milliseconds (For NG)
- 1000 milliseconds (For OK)

Malfunction Indicator Light Illumination: Illuminates as soon as malfunction occurs.

6. DTC CLEAR CONDITION

- When the OK idling cycle was completed 40 times in a row
- When "Clear Memory" was performed

7. MALFUNCTION INDICATOR LIGHT CLEAR CONDITION

- When the OK driving cycle was completed 3 times in a row
- When "Clear Memory" was performed

8. FAIL SAFE

Fix the throttle opening angle to 6°.

9. ECM OPERATION AT DTC SETTING

Memorize the freeze frame data. (For test mode \$02)

DIAGNOSTIC TROUBLE CODE (DTC) DETECTING CRITERIA

GENERAL DESCRIPTION

MEMO: