

# IGNITION

# *IG(H6DO)*

---

	<b>Page</b>
1. General Description .....	2
2. Spark Plug.....	4
3. Ignition Coil and Ignitor Assembly.....	7



# GENERAL DESCRIPTION

IGNITION

## 1. General Description

### A: SPECIFICATIONS

Item		Designation
Ignition coil and ignitor assembly	Model	FK0140
	Manufacturer	DIAMOND
Spark plug	Type and manufacturer	NGK : PLFR6A-11
	Thread size	mm 14, P = 1.25
	Spark gap	mm (in) 1.0 — 1.1 (0.039 — 0.043)

### B: COMPONENT

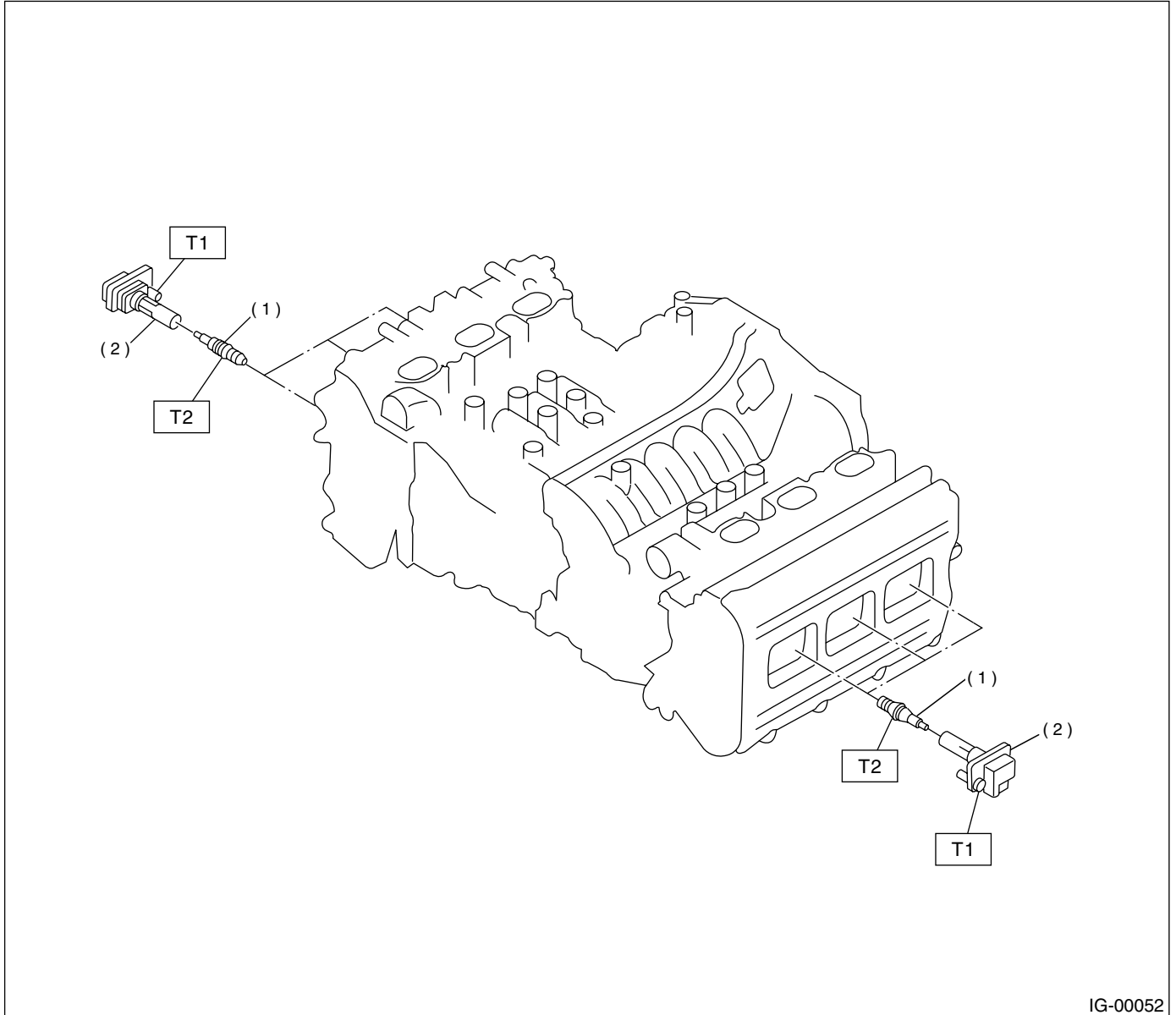

- (1) Spark plug
- (2) Ignition coil and ignitor ASSY

**Tightening torque: N-m (kgf-m, ft-lb)**

**T1: 16 (1.6, 12)**

**T2: 21 (2.1, 15)**

### **C: CAUTION**

- Wear working clothing, including a cap, protective goggles, and protective shoes during operation.
- Remove contamination including dirt and corrosion before removal, installation or disassembly.
- Keep the disassembled parts in order and protect them from dust or dirt.
- Before removal, installation or disassembly, be sure to clarify the failure. Avoid unnecessary removal, installation, disassembly, and replacement.
- Be careful not to burn your hands, because each part on the vehicle is hot after running.
- Be sure to tighten fasteners including bolts and nuts to the specified torque.
- Place shop jacks or safety stands at the specified points.
- Before disconnecting electrical connectors of sensors or units, be sure to disconnect ground cable from battery.

# SPARK PLUG

## IGNITION

### 2. Spark Plug

#### A: REMOVAL

##### CAUTION:

All spark plugs installed on an engine, must be of the same heat range.

Spark plug:

NGK: PLFR6A-11

#### 1. RH SIDE

- 1) Disconnect battery ground cable.

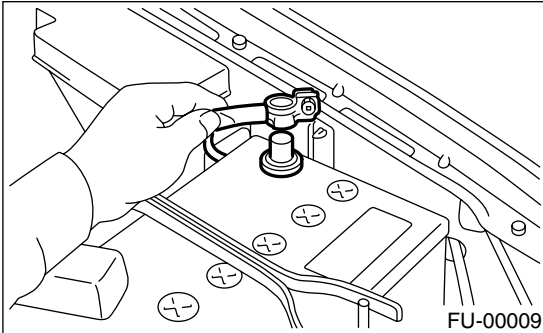

- 2) Remove air cleaner lower case. <Ref. to IN(H6DO)-5, REMOVAL, Air Cleaner.>
- 3) Disconnect connector from ignition coil.
- 4) Remove ignition coil.

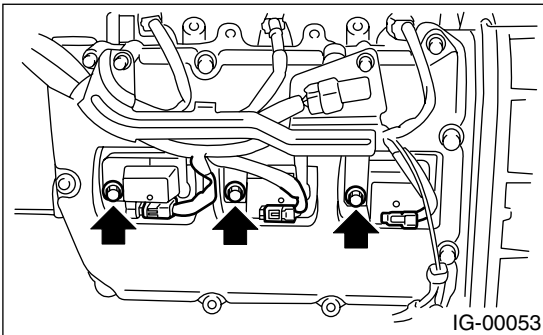

- 5) Remove spark plugs with the spark plug socket.

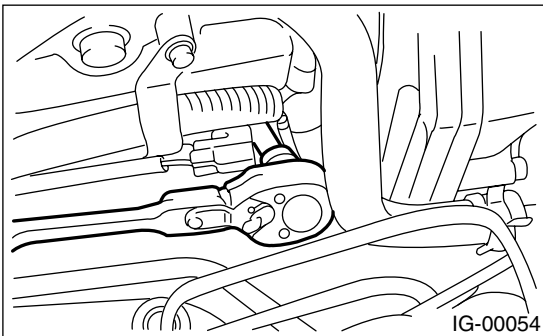

#### 2. LH SIDE

- 1) Disconnect battery cables and then remove battery and battery carrier.

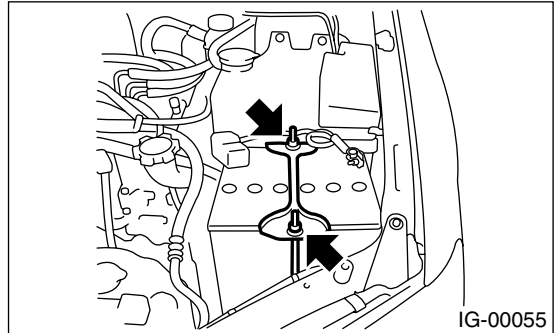

- 2) Disconnect washer motor connector.

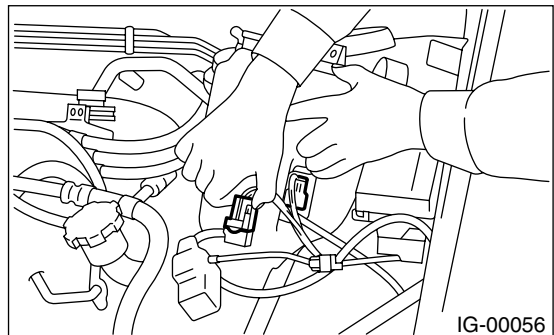

- 3) Remove the two bolts which hold the washer tank, then take the tank away from the working area.

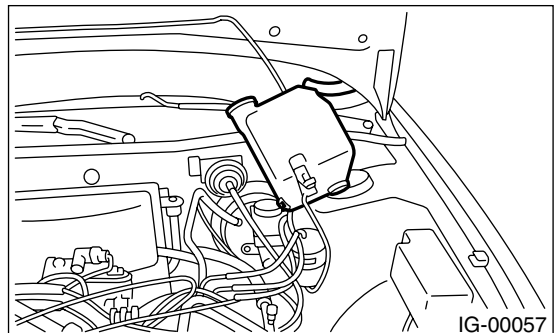

- 4) Disconnect connector from ignition coil.
- 5) Remove ignition coil.

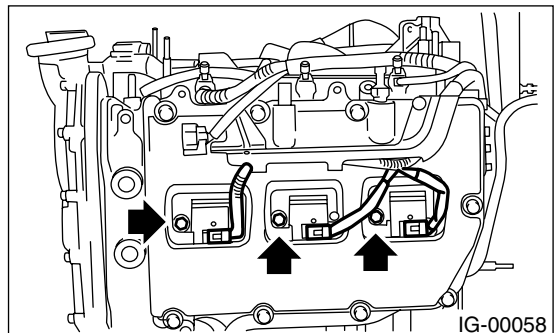

6) Remove spark plug with the spark plugs socket.

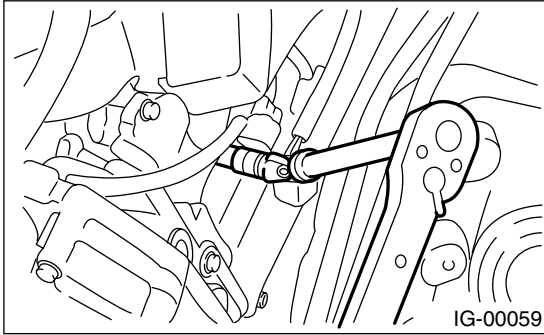

## B: INSTALLATION

### 1. RH SIDE

Install in the reverse order of removal.

**Tightening torque (Spark plug):**  
 21 N·m (2.1 kgf-m, 15 ft-lb)

#### CAUTION:

The above torque should be only applied to new spark plugs without oil on their threads. In case their threads are lubricated, the torque should be reduced by approximately 1/3 of the specified torque in order to avoid over-stressing.

**Tightening torque (Ignition coil):**  
 16 N·m (1.6 kgf-m, 12 ft-lb)

### 2. LH SIDE

Install in the reverse order of removal.

**Tightening torque (Spark plug):**  
 21 N·m (2.1 kgf-m, 15 ft-lb)

#### CAUTION:

The above torque should be only applied to new spark plugs without oil on their threads. In case their threads are lubricated, the torque should be reduced by approximately 1/3 of the specified torque in order to avoid over-stressing.

**Tightening torque (Ignition coil):**  
 16 N·m (1.6 kgf-m, 12 ft-lb)

## C: INSPECTION

Check the electrodes and inner and outer porcelain of plugs, noting the type of deposits and the degree of electrode erosion.

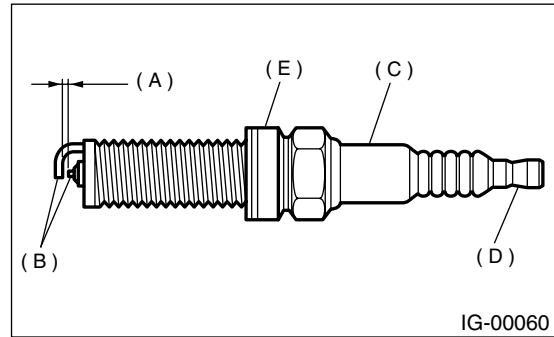

- (A) Electrode gap
- (B) Carbon accumulation or wear
- (C) Cracks
- (D) Damage
- (E) Damaged gasket

### 1) Normal:

Brown to grayish-tan deposits and slight electrode wear indicates correct spark plug heat range.

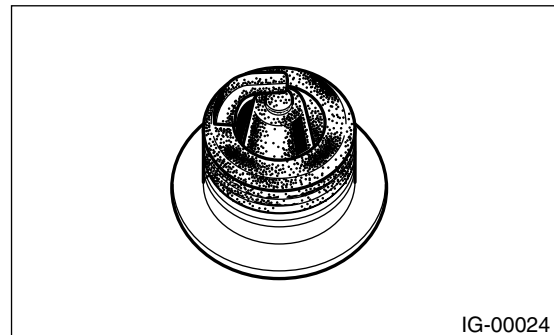

### 2) Carbon fouled:

Dry fluffy carbon deposits on insulator and electrode are mostly caused by slow speed driving in city, weak ignition, too rich fuel mixture, dirty air cleaner, etc.

It is advisable to replace with plugs having hotter heat range.

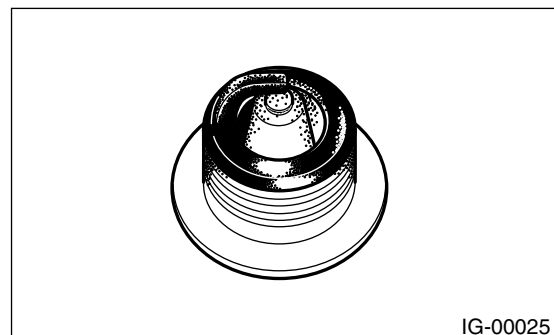

# SPARK PLUG

## IGNITION

### 3) Oil fouled:

Wet black deposits show excessive oil entrance into combustion chamber through worn rings and pistons or excessive clearance between valve guides and stems. If the same condition remains after repair, use a hotter plug.

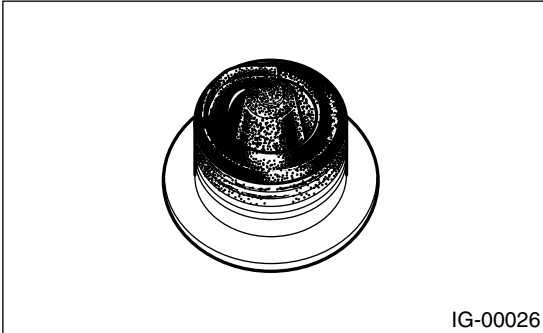

### 4) Overheating:

White or light gray insulator with black or gray brown spots and bluish burnt electrodes indicates engine overheating. Moreover, the appearance results from incorrect ignition timing, loose spark plugs, wrong selection of fuel, hotter range plug, etc. It is advisable to replace with plugs having colder heat range.

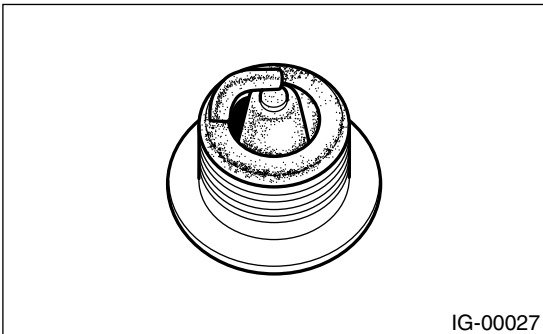

## D: CLEANING

### CAUTION:

Do not use plug cleaner because spark plugs are platinum-tipped.

## E: ADJUSTMENT

Correct it if the spark plug gap is measured with a gap gauge, and it is necessary.

### Spark plug gap: L

1.0 — 1.1 mm (0.039 — 0.043 in)

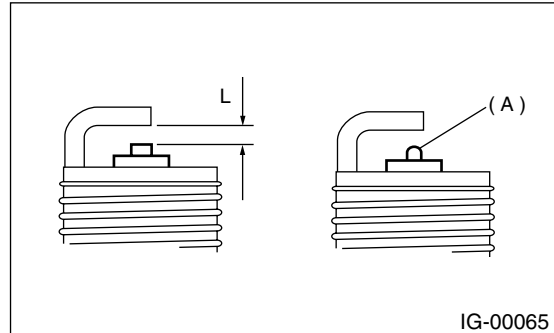

### NOTE:

Replace with new spark plug if this area (A) is worn to "ball" shape.

### 3. Ignition Coil and Ignitor Assembly

#### A: REMOVAL

Direct ignition type is adopted.

For the order of removal, refer to the removal of spark plugs.

#### B: INSTALLATION

Install in the reverse order of removal.

#### *Tightening torque:*

***16 N·m (1.6 kgf-m, 12 ft-lb)***

#### C: INSPECTION

Because ignition coil is a direct ignition type, the resistance cannot be measured in a single unit. For inspection procedure of ignition system, refer to the following. <Ref. to EN(H6DO)-84, IGNITION CONTROL SYSTEM, Diagnostics for Engine Starting Failure.>

# IGNITION COIL AND IGNITOR ASSEMBLY

IGNITION

---

**MEMO:**