

Parking Pawl

AUTOMATIC TRANSMISSION

31. Parking Pawl

A: REMOVAL

- 1) Remove the transmission assembly from vehicle body. <Ref. to 5AT-34, REMOVAL, Automatic Transmission Assembly.>
- 2) Remove the extension case. <Ref. to 5AT-65, REMOVAL, Extension Case.>
- 3) Remove the center differential carrier. <Ref. to 5AT-74, REMOVAL, Center Differential Carrier.>
- 4) Remove the front vehicle speed sensor. <Ref. to 5AT-47, REMOVAL, Front Vehicle Speed Sensor.>
- 5) Remove the parking support actuator.

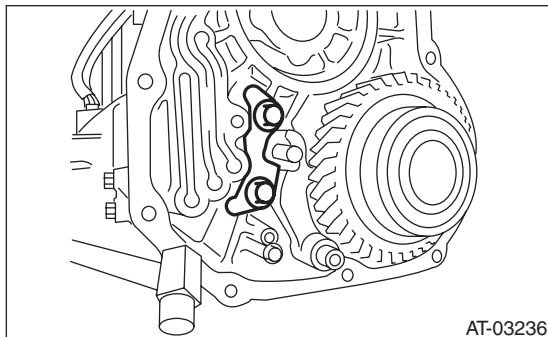

- 6) Remove the parking pawl, parking pawl shaft and return spring.

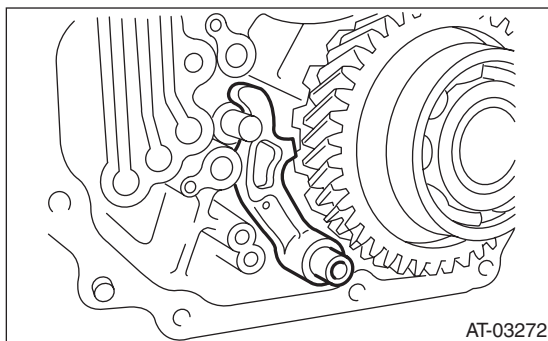

B: INSTALLATION

- 1) Set the transmission to the N range.
- 2) Install the parking pawl, parking pawl shaft and return spring.

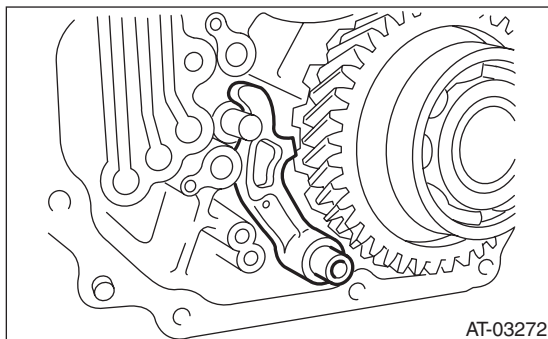

- 3) Install the parking support actuator.

Tightening torque:

$10 \pm 2 \text{ N}\cdot\text{m}$ ($1.0 \pm 0.2 \text{ kgf}\cdot\text{m}$, $7.4 \pm 1.5 \text{ ft}\cdot\text{lb}$)

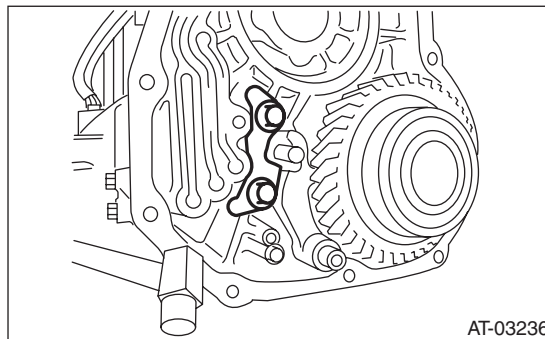

- 4) Using the ST, tighten the bolts which tightened in step 3) with specified angle.

Tightening angle:

$17^\circ \pm 2^\circ$

ST 18854AA000 ANGLE GAUGE

NOTE:

Do not use extension as much as possible.

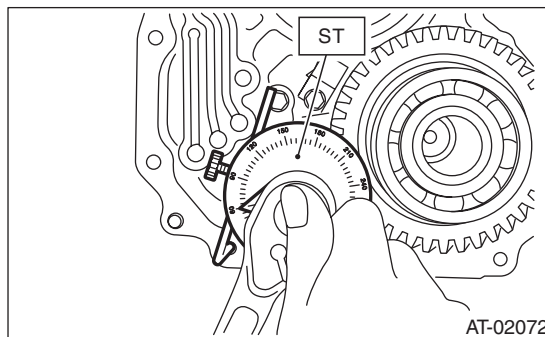
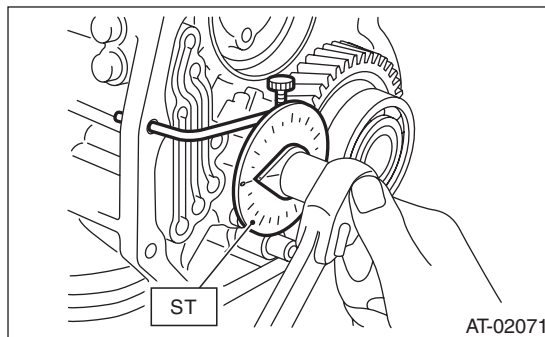

5) Make sure that the return spring is sticking out of the parking pole hole.

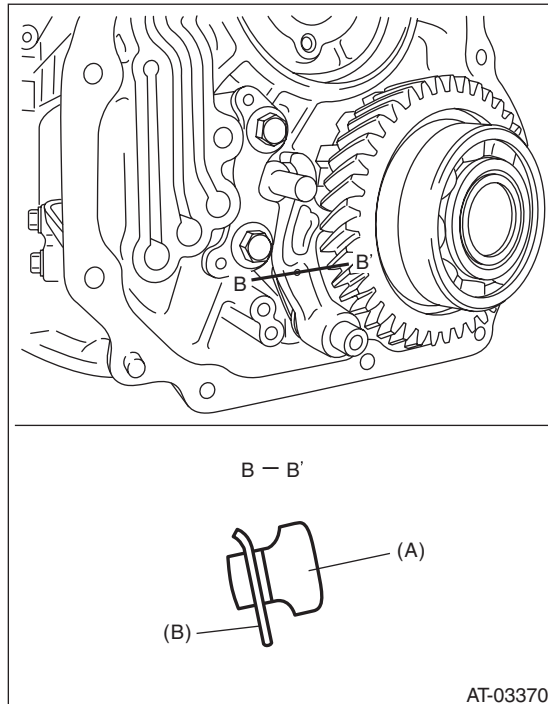

- (A) Parking pawl
- (B) Return spring

6) Install the front vehicle speed sensor. <Ref. to 5AT-47, INSTALLATION, Front Vehicle Speed Sensor.>

7) Install the center differential carrier. <Ref. to 5AT-74, INSTALLATION, Center Differential Carrier.>

8) Install the extension case. <Ref. to 5AT-65, INSTALLATION, Extension Case.>

9) Install the transmission assembly to the vehicle. <Ref. to 5AT-37, INSTALLATION, Automatic Transmission Assembly.>

C: INSPECTION

Make sure that the tab of parking pawl on reduction driven gear is not worn or otherwise damaged.