

# General Description

INTAKE (INDUCTION)

## 1. General Description

### A: COMPONENT

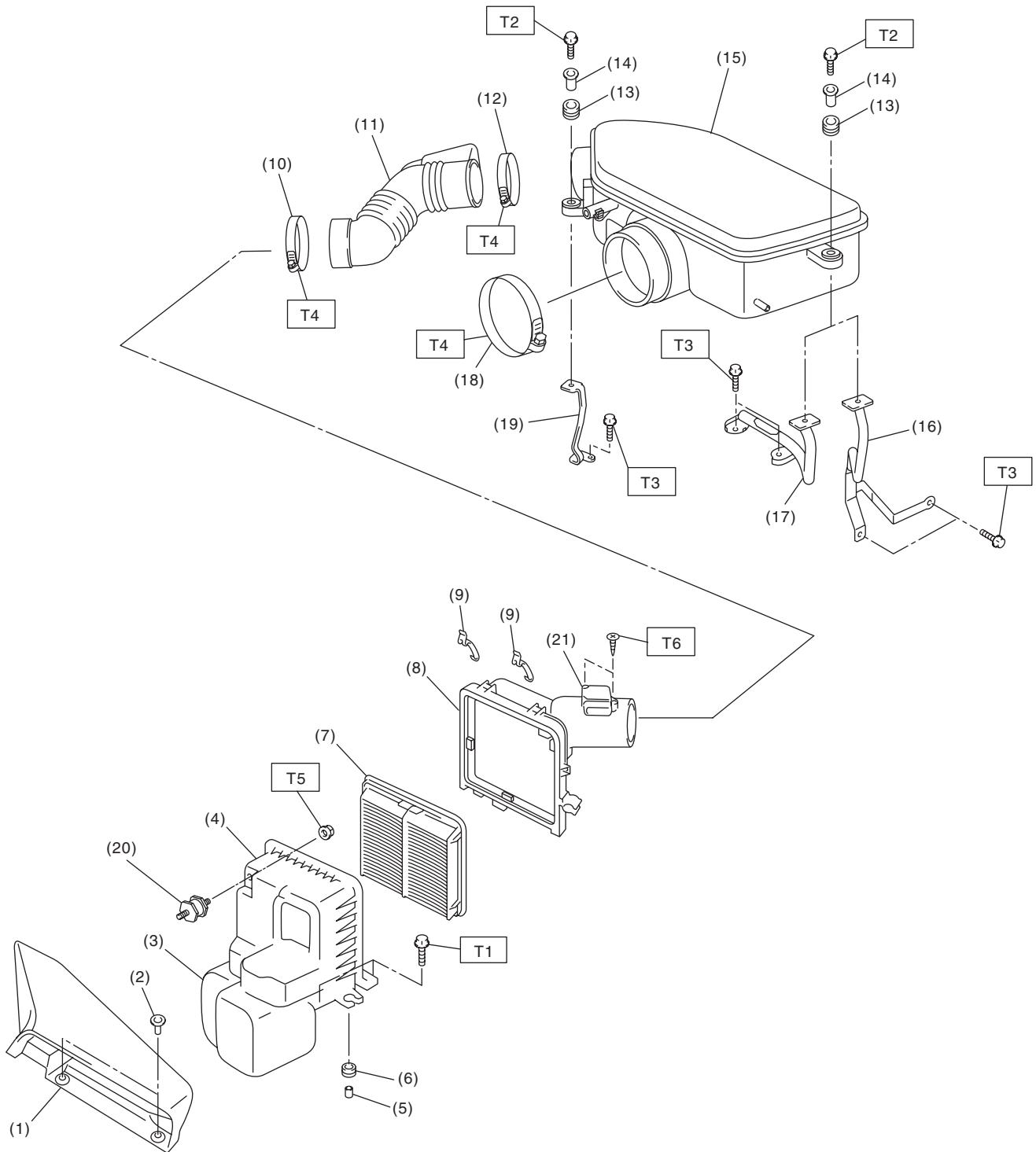

IN-02218

IN(H4SO)-2

# General Description

INTAKE (INDUCTION)

(1) Air intake duct	(11) Intake boot	(21) Mass air flow and intake air temperature sensor
(2) Clip	(12) Clamp	
(3) Resonator chamber	(13) Cushion	
(4) Air cleaner case (front)	(14) Spacer	
(5) Spacer	(15) Air intake chamber	
(6) Cushion	(16) Stay LH (MT model)	
(7) Air cleaner element	(17) Stay LH (AT model)	
(8) Air cleaner case (rear) (with HC absorption filter : U5 model)	(18) Clamp	
(9) Clip	(19) Stay RH	
(10) Clamp	(20) Cushion	

---

**Tightening torque:N·m (kgf-m, ft-lb)**

**T1: 6.0 (0.6, 4.4)**

**T2: 6.5 (0.66, 4.8)**

**T3: 16 (1.6, 11.6)**

**T4: 3.0 (0.3, 2.2)**

**T5: 7.5 (0.76, 5.5)**

**T6: 1.0 (0.10, 0.7)**

---

## B: CAUTION

- Wear appropriate work clothing, including a cap, protective goggles and protective shoes when performing any work.
- Remove contamination including dirt and corrosion before removal, installation or disassembly.
- Keep the disassembled parts in order and protect them from dust and dirt.
- Before removal, installation or disassembly, be sure to clarify the failure. Avoid unnecessary removal, installation, disassembly and replacement.
- Vehicle components are extremely hot after driving. Be wary of receiving burns from heated parts.
- Be sure to tighten fasteners including bolts and nuts to the specified torque.
- Place shop jacks or rigid racks at the specified points.
- Before disconnecting connectors of sensors or units, be sure to disconnect the ground cable from the battery.