

14. Timing Belt Cover

A: REMOVAL

NOTE:

Perform the work with the engine installed to body when replacing a single part.

- 1) Remove the V-belts. <Ref. to ME(H4SO)-37, REMOVAL, V-belt.>
- 2) Remove the crank pulley. <Ref. to ME(H4SO)-39, REMOVAL, Crank Pulley.>
- 3) Remove the timing belt cover (LH).
- 4) Remove the front timing belt cover.

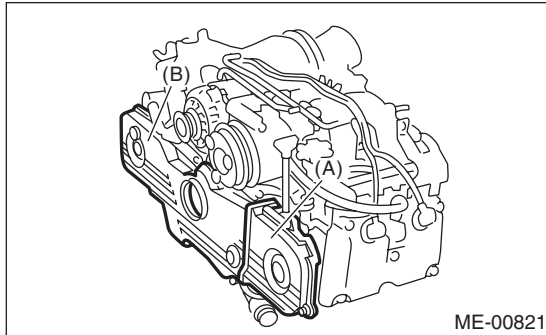

- (A) Timing belt cover (LH)
(B) Front timing belt cover

B: INSTALLATION

- 1) Install the front timing belt cover.

Tightening torque:

5 N·m (0.5 kgf·m, 3.6 ft·lb)

- 2) Install the timing belt cover (LH).

Tightening torque:

5 N·m (0.5 kgf·m, 3.6 ft·lb)

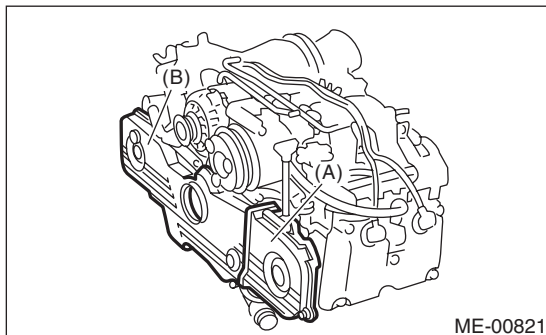

- (A) Timing belt cover (LH)
(B) Front timing belt cover

- 3) Install the crank pulley. <Ref. to ME(H4SO)-39, INSTALLATION, Crank Pulley.>
- 4) Install the V-belts. <Ref. to ME(H4SO)-37, INSTALLATION, V-belt.>

C: INSPECTION

Check the cover for damage.