

20. Cylinder Head

A: REMOVAL

NOTE:

Perform the work with the engine installed to body when replacing a single part. Refer to "Valve Clearance" for preparation. <Ref. to ME(H4SO)-27, Valve Clearance.>

- 1) Remove the V-belts. <Ref. to ME(H4SO)-37, REMOVAL, V-belt.>
- 2) Remove the crank pulley. <Ref. to ME(H4SO)-39, REMOVAL, Crank Pulley.>
- 3) Remove the timing belt cover. <Ref. to ME(H4SO)-40, REMOVAL, Timing Belt Cover.>
- 4) Remove the timing belt. <Ref. to ME(H4SO)-41, REMOVAL, Timing Belt.>
- 5) Remove the cam sprocket. <Ref. to ME(H4SO)-46, REMOVAL, Cam Sprocket.>
- 6) Remove the intake manifold. <Ref. to FU(H4SO)-12, REMOVAL, Intake Manifold.>
- 7) Remove the bolt which installs the A/C compressor bracket on cylinder head.
- 8) Remove the valve rocker assembly. <Ref. to ME(H4SO)-48, REMOVAL, Valve Rocker Assembly.>
- 9) Remove the camshaft. <Ref. to ME(H4SO)-51, REMOVAL, Camshaft.>
- 10) Remove the cylinder head bolts in alphabetical sequence as shown in the figure.

NOTE:

Leave bolts (a) and (c) engaged by three or four threads to prevent the cylinder head from falling.

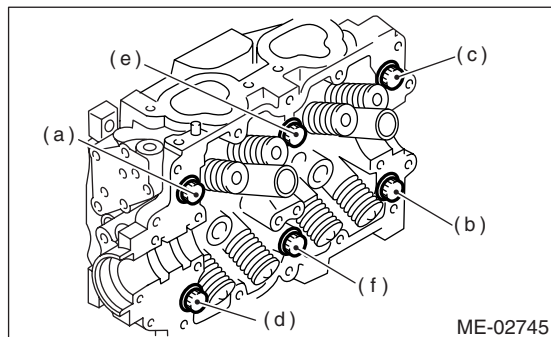

- 11) While tapping the cylinder head with a plastic hammer, separate it from cylinder block.

- 12) Remove the bolts (a) and (c) to remove cylinder head.

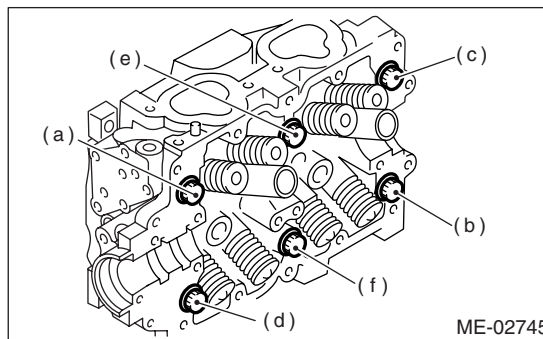

- 13) Remove the cylinder head gasket.

CAUTION:

Be careful not to scratch the mating surface of cylinder head and cylinder block.

- 14) Similarly, remove the right side cylinder head.

B: INSTALLATION

- 1) Install the cylinder head to the cylinder block.

CAUTION:

Be careful not to scratch the mating surface of cylinder head and cylinder block.

NOTE:

Use a new cylinder head gasket.

- (1) Clean the bolt threads and the bolt holes in the cylinder block.

CAUTION:

To avoid erroneous tightening of the bolts, clean out the bolt holes sufficiently by blowing with compressed air to eliminate engine coolant etc.

- (2) Apply a sufficient coat of engine oil to the washer and bolt thread.
- (3) Tighten all bolts to 40 N·m (4.1 kgf-m, 29.5 ft-lb) in alphabetical order.
- (4) Retighten all bolts to 95 N·m (9.7 kgf-m, 70.1 ft-lb) in alphabetical order.

CAUTION:

If the bolt makes stick-slip sound during tightening, repeat the procedure from step (1). In this case, the cylinder head gasket can be re-used.

- (5) Loosen all the bolts by 180° in the reverse order of installing, and loosen them further by 180°.
- (6) Tighten all bolts to 10 N·m (1.0 kgf-m, 7.4 ft-lb) in alphabetical order.
- (7) Retighten all bolts to 30 N·m (3.1 kgf-m, 22.1 ft-lb) in alphabetical order.
- (8) Retighten all bolts to 60 N·m (6.1 kgf-m, 44.3 ft-lb) in alphabetical order.
- (9) Retighten all bolts by 80 — 90° in alphabetical order.

Cylinder Head

MECHANICAL

(10) Retighten all bolts by 40 — 45° in alphabetical order.

CAUTION:

The tightening angle of the bolt should not exceed 45°.

(11) Retighten bolts (a) and (b) by 40 — 45°.

CAUTION:

Make sure the total “tightening angle” of steps (10) and (11) does not exceed 90°.

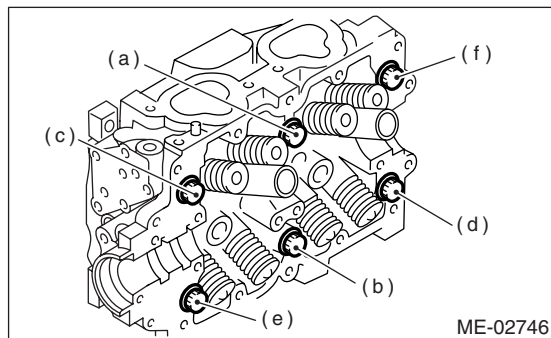

2) Install the camshaft. <Ref. to ME(H4SO)-52, INSTALLATION, Camshaft.>

3) Install the valve rocker assembly. <Ref. to ME(H4SO)-48, INSTALLATION, Valve Rocker Assembly.>

4) Install the A/C compressor bracket on cylinder head.

5) Install the intake manifold.

<Ref. to FU(H4SO)-13, INSTALLATION, Intake Manifold.>

6) Install the cam sprocket. <Ref. to ME(H4SO)-46, INSTALLATION, Cam Sprocket.>

7) Install the timing belt. <Ref. to ME(H4SO)-42, INSTALLATION, Timing Belt.>

8) Adjust the valve clearance. <Ref. to ME(H4SO)-28, ADJUSTMENT, Valve Clearance.>

9) Install the rocker cover and rocker cover gasket, and then connect PCV hose.

NOTE:

Use a new gasket.

10) Install the timing belt cover.

<Ref. to ME(H4SO)-40, INSTALLATION, Timing Belt Cover.>

11) Install the crank pulley. <Ref. to ME(H4SO)-39, INSTALLATION, Crank Pulley.>

12) Install the V-belts. <Ref. to ME(H4SO)-37, INSTALLATION, V-belt.>

C: DISASSEMBLY

1) Place the cylinder head on the ST.

ST 498267800 CYLINDER HEAD TABLE

2) Set the ST on valve spring. Compress the valve spring and remove the valve spring retainer key. Remove each valve and valve spring.

ST 499718000 VALVE SPRING REMOVER

NOTE:

- Keep all the removed parts in order for re-installing in their original positions.
- Mark each valve to prevent confusion.
- Pay careful attention not to damage the lips of intake valve oil seals and exhaust valve oil seals.

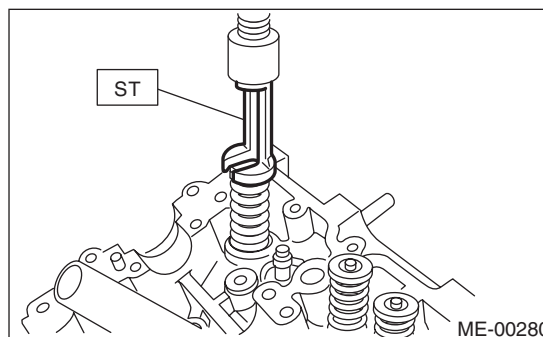

D: ASSEMBLY

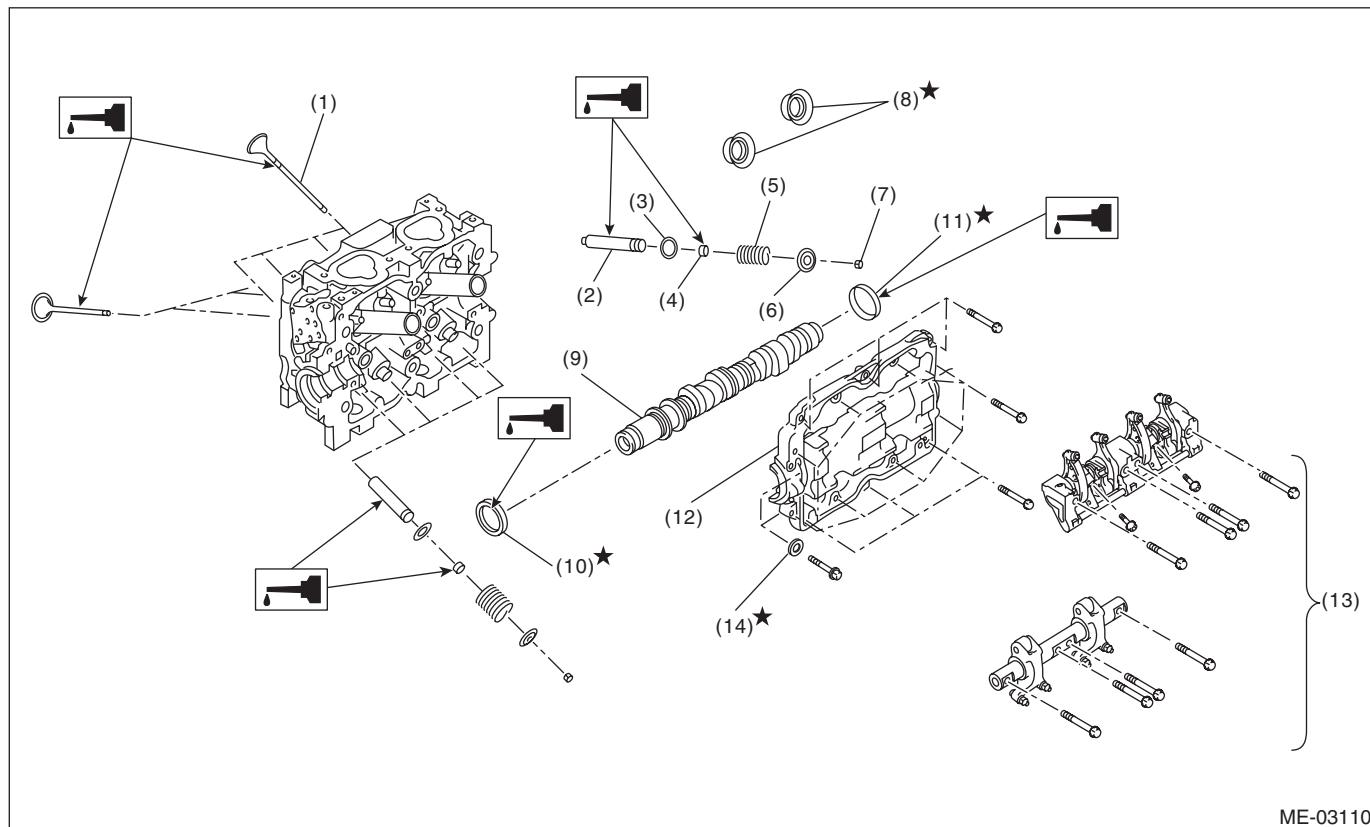

ME-03110

- | | | |
|-----------------------|-----------------------|------------------------|
| (1) Valve | (6) Retainer | (11) Plug |
| (2) Valve guide | (7) Retainer key | (12) Camshaft cap |
| (3) Valve spring seat | (8) Spark plug gasket | (13) Valve rocker ASSY |
| (4) Oil seal | (9) Camshaft | (14) Seal washer |
| (5) Valve spring | (10) Oil seal | |

- 1) Installation of valve spring and valve:
 (1) Place the cylinder head on the ST.
 ST 498267800 CYLINDER HEAD TABLE
 (2) Coat the stem of each valve with engine oil and insert the valve into the valve guide.

NOTE:

When inserting the valve into valve guide, use special care not to damage the oil seal lip.

- (3) Install the valve spring and retainer.

NOTE:

Be sure to install the valve spring with its close-coiled end facing the seat on cylinder head.

- (4) Set the ST on valve spring.

ST 499718000 VALVE SPRING REMOVER

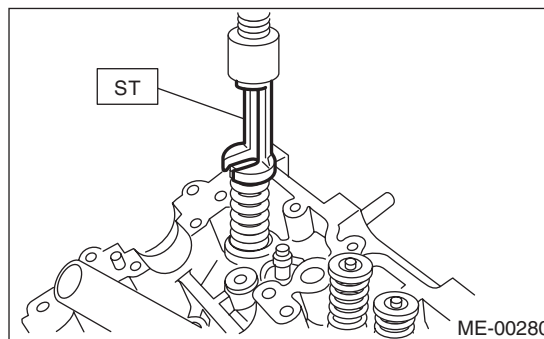

ME-00280

Cylinder Head

MECHANICAL

(5) Compress the valve spring and fit the valve spring retainer key.

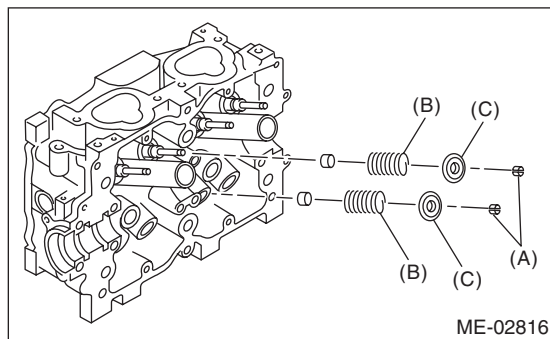

- (A) Retainer key
- (B) Valve spring
- (C) Retainer

(6) After installing, tap the valve spring retainers lightly with a plastic hammer for better seating.

E: INSPECTION

1. CYLINDER HEAD

1) Check for cracks or damage. Use liquid penetrant tester on the important sections to check for fissures. Check that there are no marks of gas leaking or water leaking on gasket installing surface.

2) Place the cylinder head on the ST.

ST 498267800 CYLINDER HEAD TABLE

3) Measure the warping of the cylinder head surface that mates with the cylinder block using a straight edge and thickness gauge.

If the warping exceeds the limit, correct the surface by grinding it with a surface grinder.

Warping limit:

0.035 mm (0.0014 in)

Grinding limit:

0.1 mm (0.004 in)

Standard height of cylinder head:

97.5 mm (3.839 in)

NOTE:

Uneven torque for the cylinder head bolts can cause warping. When reassembling, pay special attention to the torque so as to tighten evenly.

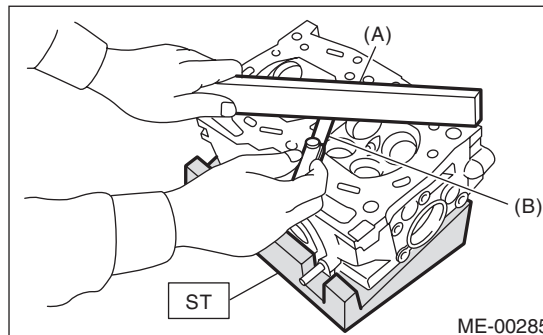

- (A) Straight edge
- (B) Thickness gauge

2. VALVE SEAT

Inspect the intake and exhaust valve seats, and correct the contact surfaces with a valve seat cutter if they are defective or when valve guides are replaced.

Valve seat width W:

Standard:

Intake (A)

0.8 — 1.4 mm (0.03 — 0.055 in)

Exhaust (B)

1.2 — 1.8 mm (0.047 — 0.071 in)

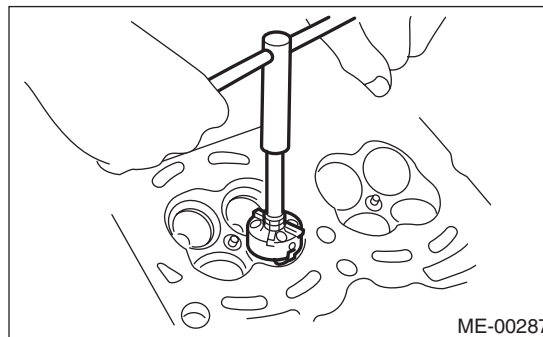
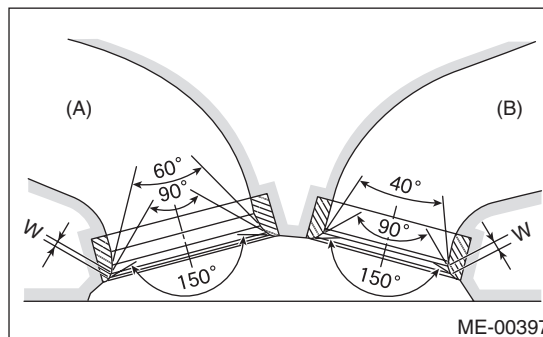

3. VALVE GUIDE

1) Check the clearance between valve guide and stem. The clearance can be checked by measuring respectively the outer diameter of valve stem with a micrometer and the inner diameter of valve guide with a caliper gauge.

Clearance between the valve guide and valve stem:

Standard:

Intake

0.035 — 0.062 mm (0.0014 — 0.0024 in)

Exhaust

0.040 — 0.067 mm (0.0016 — 0.0026 in)

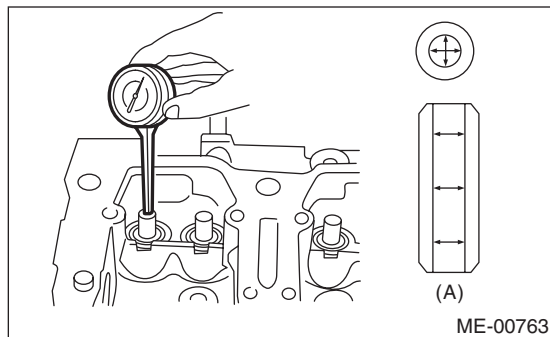

(A) Valve guide

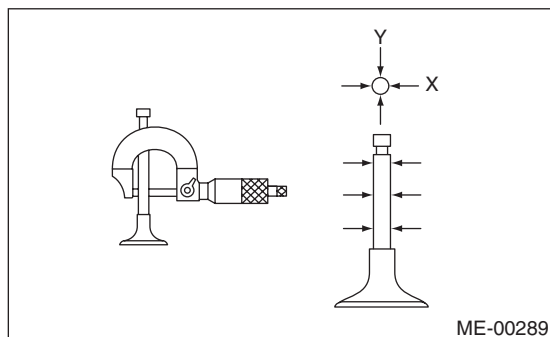

2) If the clearance between valve guide and stem exceeds the limit, replace the valve guide or valve itself whichever shows greater amount of wear. See the following procedure for valve guide replacement.

Valve guide inner diameter:

6.000 — 6.012 mm (0.2362 — 0.2367 in)

Valve stem outer diameters:

Intake

5.950 — 5.965 mm (0.2343 — 0.2348 in)

Exhaust

5.945 — 5.960 mm (0.2341 — 0.2346 in)

(1) Place the cylinder head on ST1 with the combustion chamber upward so that valve guides fit the holes in ST1.

(2) Insert the ST2 into valve guide and press it down to remove the valve guide.

ST1 498267800 CYLINDER HEAD TABLE
ST2 499767200 VALVE GUIDE REMOVER

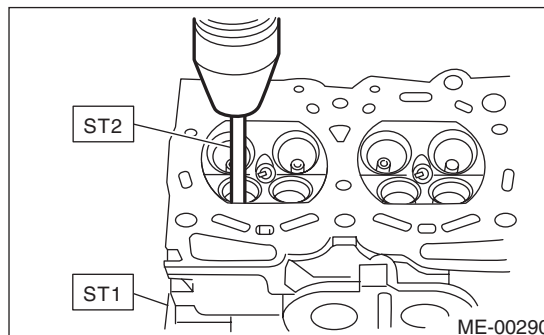

(3) Turn the cylinder head upside down and place the ST as shown in the figure.

Intake side

ST 499767700 VALVE GUIDE ADJUSTER

Exhaust side

ST 499767800 VALVE GUIDE ADJUSTER

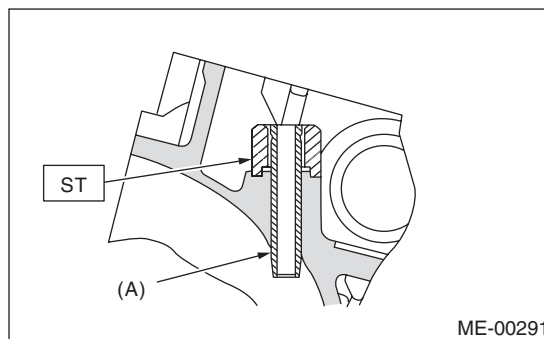

(A) Valve guide

(4) Before installing a new valve guide, make sure that neither scratches nor damages exist on the inner surface of valve guide holes in cylinder head.

Cylinder Head

MECHANICAL

(5) Put a new valve guide, coated with sufficient oil, in cylinder, and insert the ST1 into valve guide. Press in until the valve guide upper end is flush with the upper surface of ST2.

ST1 499767200 VALVE GUIDE REMOVER
Intake side

ST2 499767700 VALVE GUIDE ADJUSTER
Exhaust side

ST2 499767800 VALVE GUIDE ADJUSTER

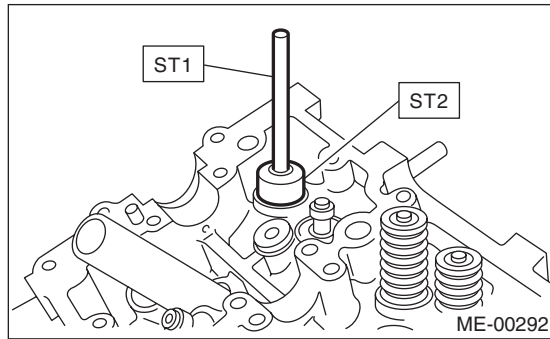

(6) Check the valve guide protrusion.

Valve guide protrusion L:

Intake

20.0 — 21.0 mm (0.787 — 0.827 in)

Exhaust

16.5 — 17.5 mm (0.650 — 0.689 in)

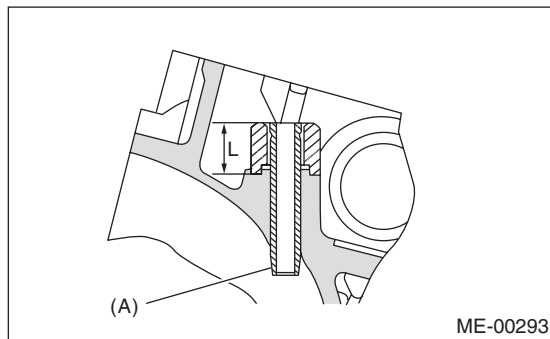

(A) Valve guide

(7) Ream the inside of valve guide using ST. Put the ST in valve guide, and rotate the ST slowly clockwise while pushing it lightly. Bring the ST back while rotating it clockwise.

NOTE:

- Apply engine oil to the ST when reaming.
- If the inner surface of valve guide is damaged, the edge of ST should be slightly ground with oil stone.
- If the inner surface of valve guide becomes lustrous and the ST does not chip, use a new ST or remedy the ST.

(8) After reaming, clean the valve guide to remove chips.

(9) Recheck the contact condition between valve and valve seat after replacing the valve guide.

ST 499767400 VALVE GUIDE REAMER

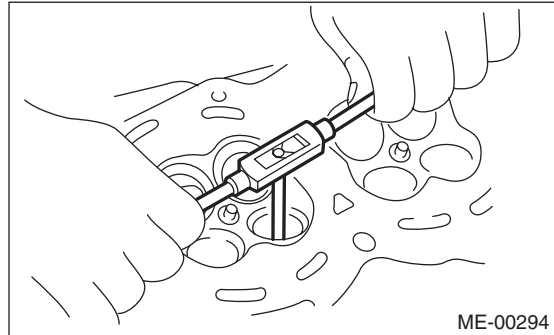

4. INTAKE AND EXHAUST VALVE

1) Inspect the flange and stem of valve, and replace if damaged, worn, or deformed, or if H is outside of the specified limit.

H:

Intake

Standard:

0.8 — 1.2 mm (0.03 — 0.047 in)

Exhaust

Standard:

1.0 — 1.4 mm (0.039 — 0.055 in)

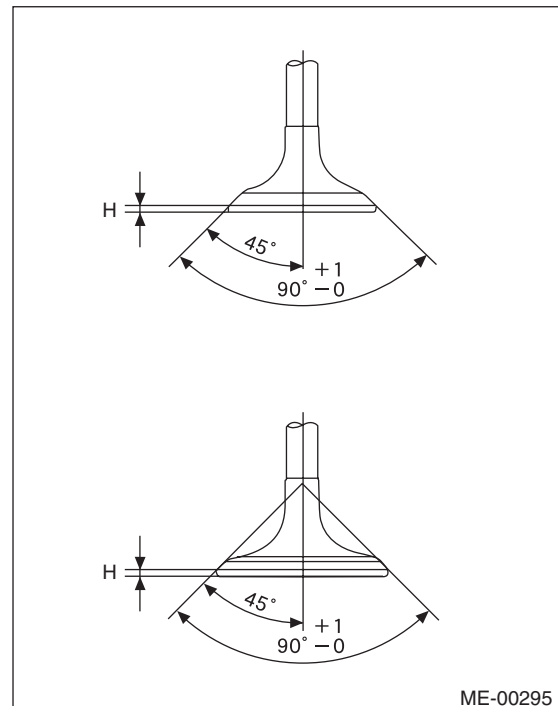

2) Put a small amount of grinding compound on the seat surface, and lap the valve and seat surface. Replace with a new valve oil seal after lapping.

NOTE:

It is possible to differentiate between the intake valve and the exhaust valve by their overall length.

Valve overall length:

Intake

120.6 mm (4.75 in)

Exhaust

121.7 mm (4.79 in)

5. VALVE SPRING

- 1) Check the valve springs for damage, free length, and tension. Replace the valve spring if it is not within the standard value presented in the table.
- 2) To measure the squareness of the valve spring, stand the spring on a surface plate and measure its deflection at the top of spring using a try square.

Free length mm (in)		55.2 (2.173)
Tension/spring height N (kgf, lb)/mm (in)	Set	235.3 — 270.7 (24 — 27.6, 52.9 — 60.8)/45.0 (1.772)
	Lift	578.9 — 639.9 (59.1 — 65.3, 130.3 — 143.9)/ 34.7 (1.366)
Squareness		2.5°, 2.4 mm (0.094 in) or less

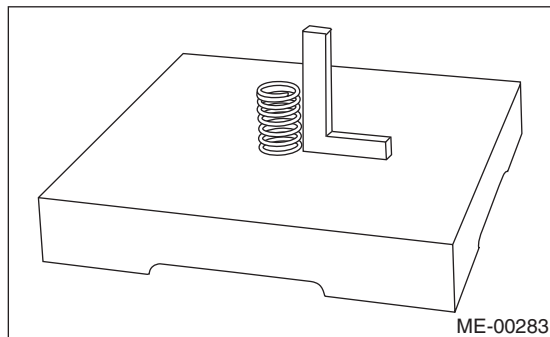

6. INTAKE AND EXHAUST VALVE OIL SEAL

1) For the following, remove the oil seal from the valve guide and replace it with a new part.

- When the lip is damaged.
- When the spring is out of the specified position.
- When readjusting the surfaces of valve and valve seat.
- When replacing the valve guide.

2) Place the cylinder head on ST1.

3) Using the ST2, press in the oil seal.

ST1 498267800 CYLINDER HEAD TABLE

ST2 498857100 VALVE OIL SEAL GUIDE

NOTE:

- Apply engine oil to oil seal before press-fitting.
- When press-fitting the oil seal, do not use a hammer or strike in.
- The intake valve oil seal and exhaust valve oil seal can be distinguished by colors.

Color of rubber part:

Intake [Gray]

Exhaust [Green]

