

General Description

SPEED CONTROL SYSTEMS

1. General Description

A: SPECIFICATION

Accelerator pedal	Stroke	At pedal pad	50 — 63 mm (1.97 — 2.48 in)
-------------------	--------	--------------	-----------------------------

B: COMPONENT

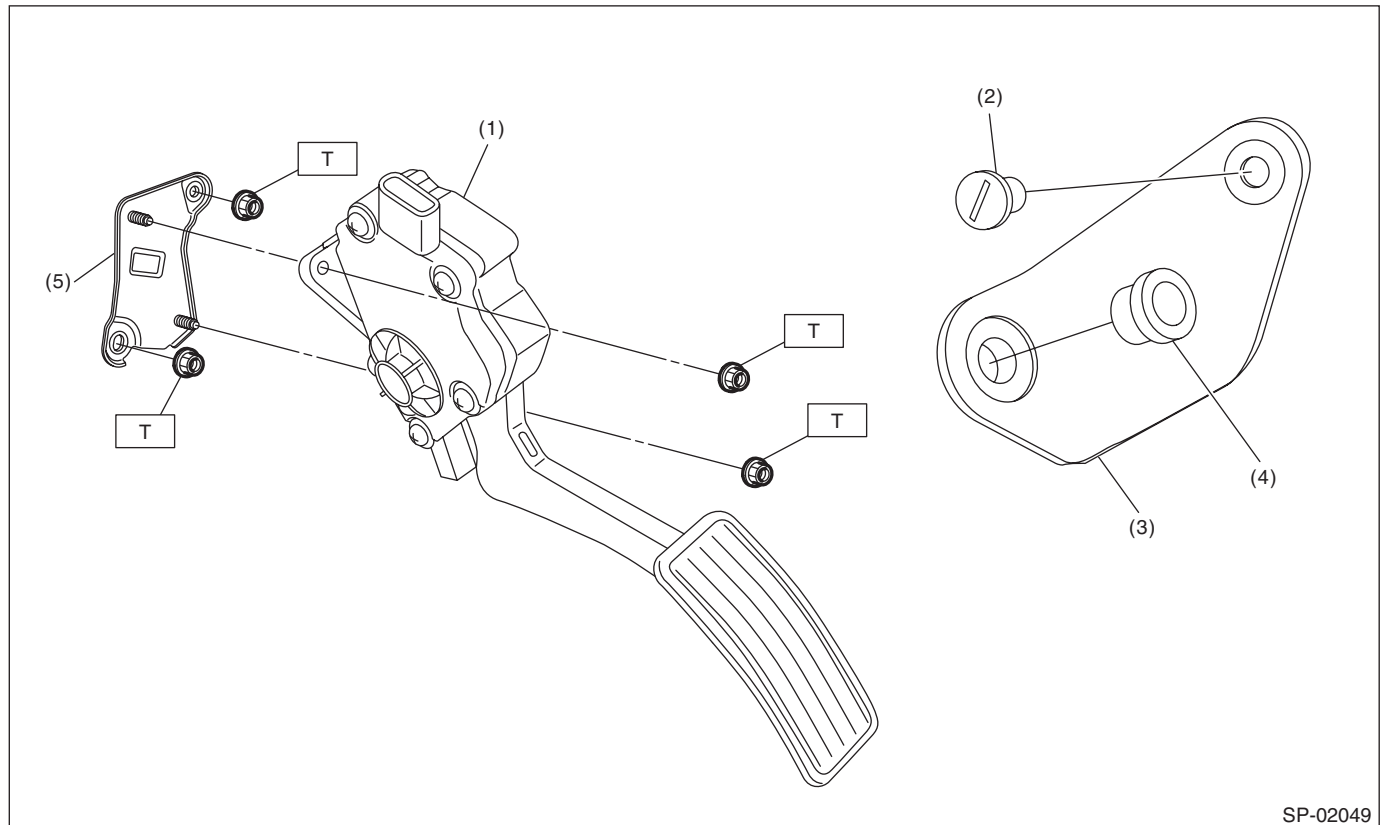

SP-02049

- | | |
|----------------------------|-------------------------------|
| (1) Accelerator pedal ASSY | (4) Stopper |
| (2) Accelerator plate | (5) Accelerator pedal bracket |
| (3) Clip | |

Tightening torque: N·m (kgf·m, ft·lb)
T: 18 (1.8, 13.0)

C: CAUTION

- Wear appropriate work clothing, including a cap, protective goggles and protective shoes when performing any work.
- Remove contamination including dirt and corrosion before removal or installation.
- Keep the parts in order and protect them from dust and dirt.
- Before removal or installation, be sure to clarify the failure. Avoid unnecessary removal, installation, disassembly and replacement.
- Vehicle components are extremely hot after driving. Be wary of receiving burns from heated parts.
- Be sure to tighten fasteners including bolts and nuts to the specified torque.
- Place shop jacks or rigid racks at the specified points.
- Before disconnecting connectors of sensors or units, be sure to disconnect the ground cable from the battery.