

General Description

STARTING/CHARGING SYSTEMS

1. General Description

A: SPECIFICATION

Item		Specification		
Vehicle model		MT	AT	
Starter	Type	Reduction type		
	Model	428000-2300	428000-2291	
	Manufacturer	DENSO		
	Voltage and output	12 V — 1.0 kW	12 V — 1.4 kW	
	Direction of rotation	Counterclockwise (when observed from pinion)		
	Number of pinion teeth	9	9	
	No-load characteristics	Voltage	11 V	11 V
		Current	90 A or less	90 A or less
		Rotating speed	1,820 rpm or more	1,720 rpm or more
	Load characteristics	Voltage	8 V	8 V
		Current	280 A	370 A
		Torque	7.76 N·m (0.79 kgf-m, 5.7 ft-lb) or more	12.78 N·m (1.30 kgf-m, 9.4 ft-lb) or more
		Rotating speed	900 rpm or more	850 rpm or more
	Lock characteristics	Voltage	3 V	3 V
		Current	900 A or less	900 A or less
Torque		13.62 N·m (1.39 kgf-m, 10.0 ft-lb) or more	15.42 N·m (1.57 kgf-m, 11.3 ft-lb) or more	
Generator	Type	Rotating-field three-phase type, voltage regulator built-in type, with load response control system		
	Model	2.5 L Non-turbo	A003TG2391ZC	
		3.0 L Non-turbo	A003TB1891	
		2.5 L Turbo	A003TG0491	
	Manufacturer	Mitsubishi Electric		
	Voltage and output	12V — 110A		
	Polarity on ground side	Negative		
	Direction of rotation	Clockwise (when observed from pulley side)		
	Armature connection	3-phase Y-type		
	Output current	1,500 rpm — 50 A or more 2,500 rpm — 91 A or more 5,000 rpm — 105 A or more		
Regulated voltage	14.1 — 14.8 V [20°C (68°F)]			
Battery	Type and capacity	12 V — 48 AH (55D23L)	12 V — 52 AH (75D23L)	

B: COMPONENT

1. STARTER

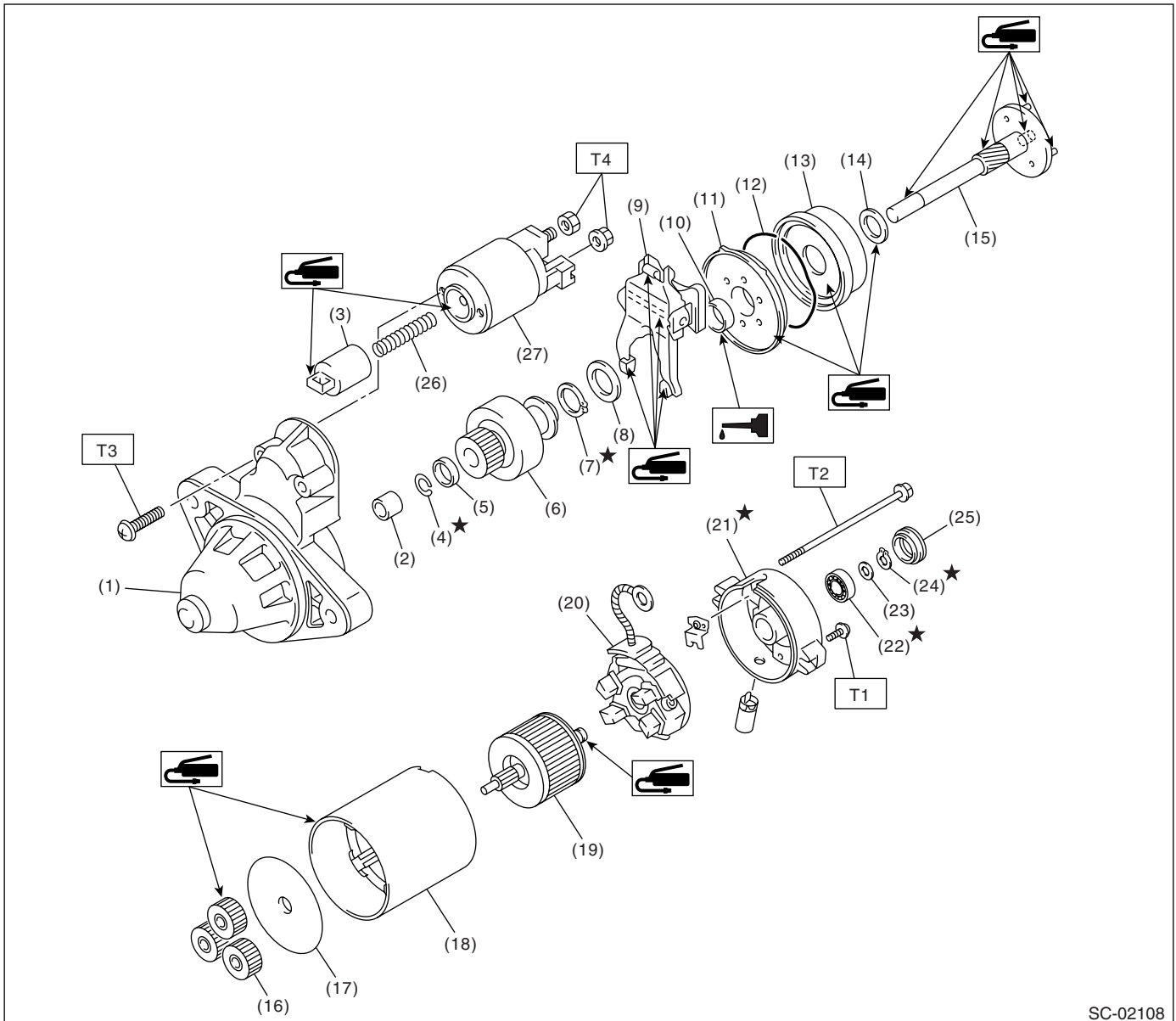

SC-02108

- | | | |
|-----------------------------|------------------------|----------------------|
| (1) Front bracket | (12) Wave washer | (23) Space ring |
| (2) Front bearing | (13) Internal gear | (24) Snap ring |
| (3) Plunger | (14) Washer | (25) End frame cover |
| (4) Snap ring | (15) Shaft | (26) Plunger spring |
| (5) Stopper | (16) Planetary gear | (27) Magnet switch |
| (6) Overrunning clutch | (17) Armature plate | |
| (7) Snap ring | (18) Yoke | |
| (8) Washer | (19) Armature | |
| (9) Lever | (20) Brush holder ASSY | |
| (10) Oilless bearing | (21) End frame | |
| (11) Shock absorber bearing | (22) Rear bearing | |

Tightening torque: N·m (kgf·m, ft·lb)

T1: 1.4 (0.14, 1.03)

T2: 6 (0.6, 4.4)

T3: 7.5 (0.8, 5.5)

T4: 10 (1.0, 7.4)

General Description

STARTING/CHARGING SYSTEMS

2. GENERATOR

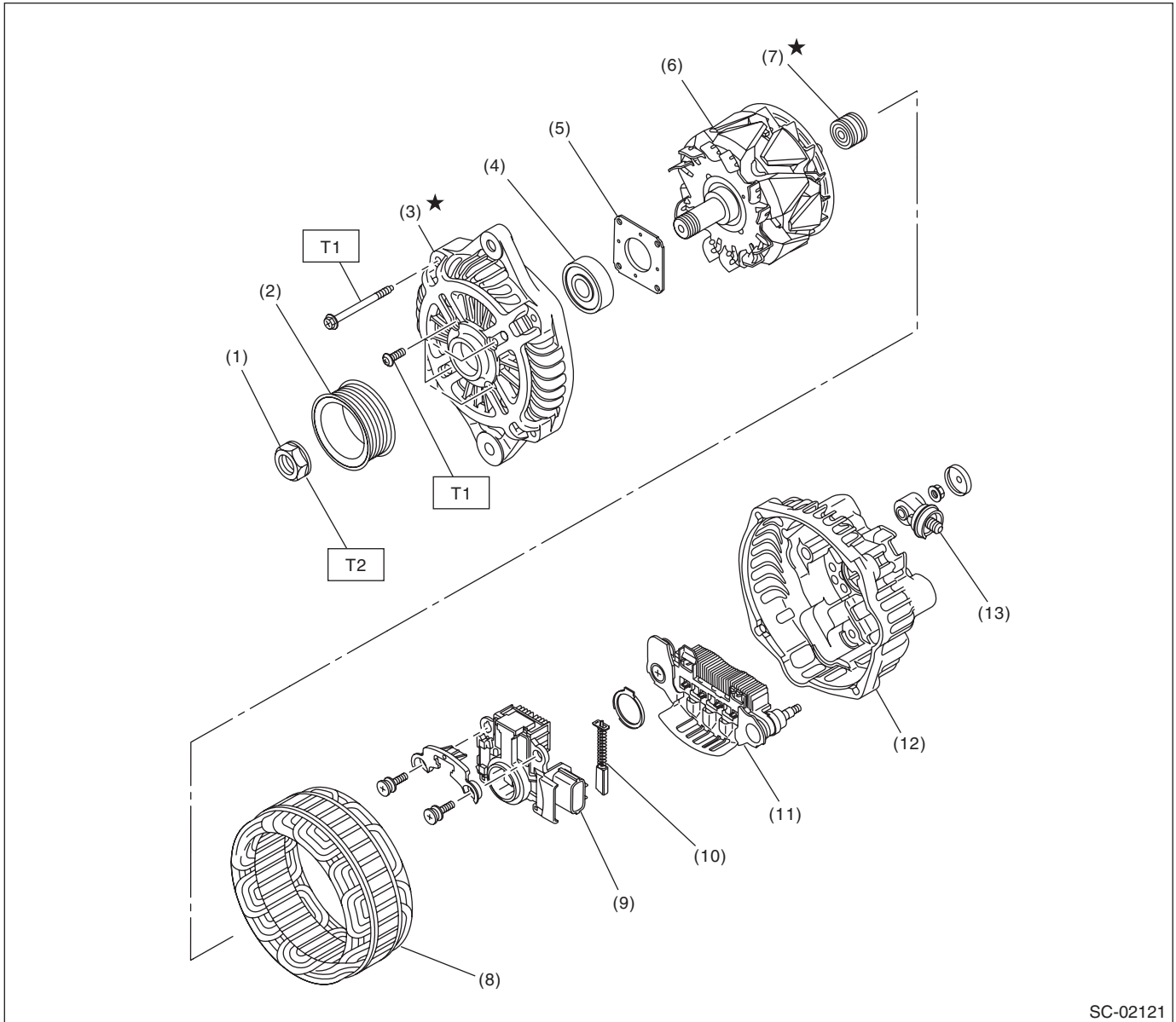

SC-02121

- | | | |
|----------------------|-----------------------------|---------------|
| (1) Pulley nut | (7) Bearing | (13) Terminal |
| (2) Pulley | (8) Stator coil | |
| (3) Front cover | (9) IC regulator with brush | |
| (4) Ball bearing | (10) Brush | |
| (5) Bearing retainer | (11) Rectifier | |
| (6) Rotor | (12) Rear cover | |

Tightening torque: N·m (kgf·m, ft·lb)

T1: 4.7 (0.48, 3.5)

T2: 108 (11.0, 80)

C: CAUTION

- Wear appropriate work clothing, including a cap, protective goggles and protective shoes when performing any work.
- Remove contamination including dirt and corrosion before removal, installation or disassembly.
- Keep the disassembled parts in order and protect them from dust and dirt.
- Before removal, installation or disassembly, be sure to clarify the failure. Avoid unnecessary removal, installation, disassembly and replacement.
- Vehicle components are extremely hot after driving. Be wary of receiving burns from heated parts.
- Be sure to tighten fasteners including bolts and nuts to the specified torque.
- Place shop jacks or rigid racks at the specified points.
- Before disconnecting connectors of sensors or units, be sure to disconnect the ground cable from the battery.