

# Starter

## STARTING/CHARGING SYSTEMS

### 2. Starter

#### A: REMOVAL

1) Disconnect the ground cable from the battery.

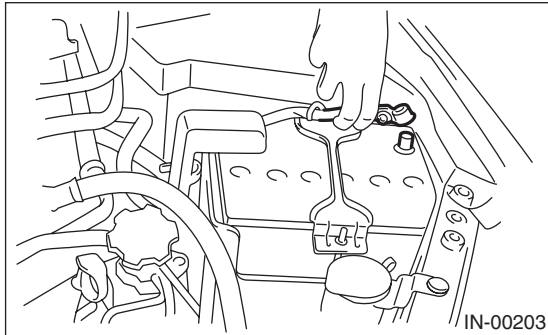

2) Remove the air intake chamber. (Non-turbo model) <Ref. to IN(H4SO)-7, REMOVAL, Air Intake Chamber.> <Ref. to IN(H6DO)-6, REMOVAL, Air Intake Chamber.>

3) Remove the intercooler. (Turbo model)<Ref. to IN(H4DOTC)-12, REMOVAL, Intercooler.>

4) Remove the air intake chamber stay LH. (2.5 L non-turbo model)

5) Disconnect the connector and terminal from starter.

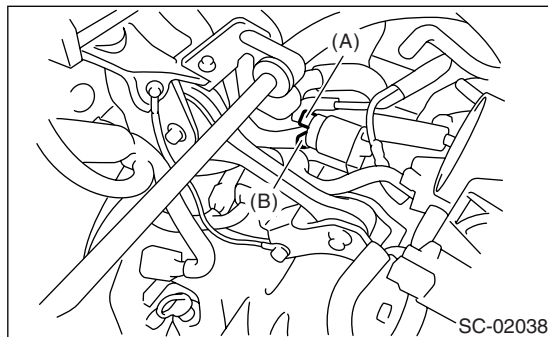

- (A) Terminal
- (B) Connector

6) Remove the starter from transmission.

#### B: INSTALLATION

Install in the reverse order of removal.

**Tightening torque:**

**50 N·m (5.1 kgf·m, 37 ft·lb)**

#### C: DISASSEMBLY

##### 1. STARTER ASSEMBLY

1) Loosen the nut which holds terminal M of magnet switch assembly, and then disconnect the harness from terminal.

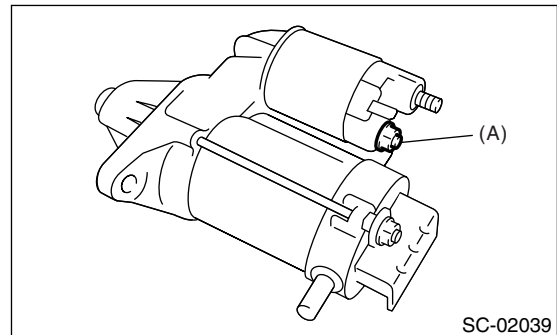

- (A) Terminal M

2) Remove the bolts which hold switch assembly, and then remove the switch assembly, plunger and plunger spring from starter.

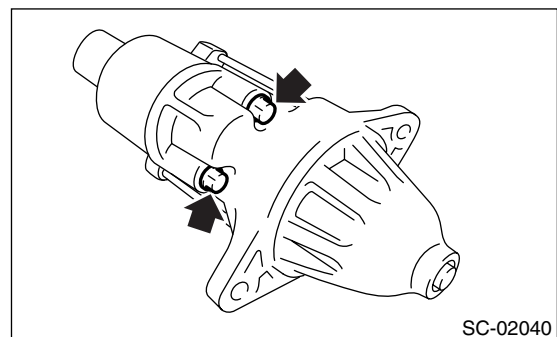

3) Remove the nuts of both sides, and then remove the rear cover.

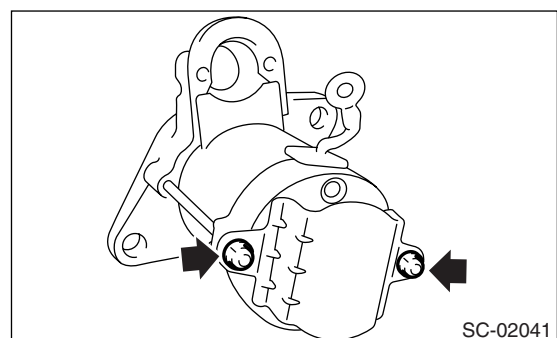

4) Remove the through-bolts of bolt side, and then detach the end frame and armature from yoke as a unit.

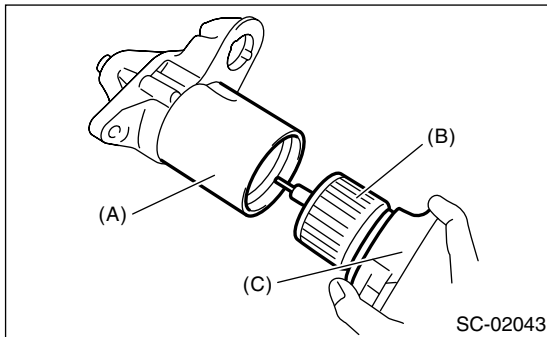
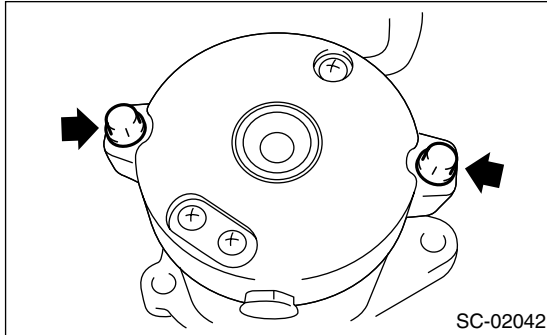

- (A) Yoke
- (B) Armature
- (C) End frame

5) Remove the end frame cover.

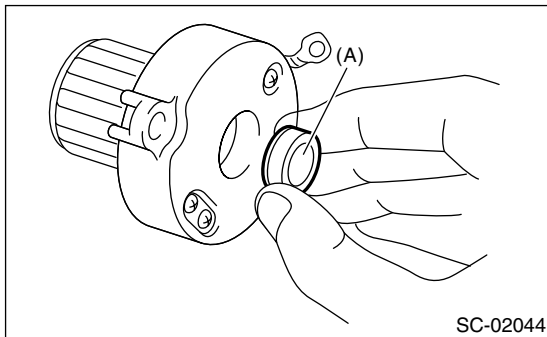

- (A) End frame cover

6) Remove the snap ring.

7) Remove the space ring.

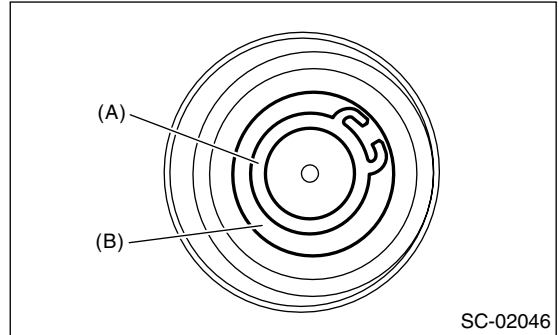
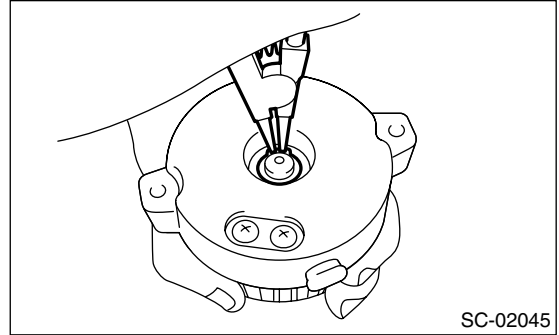

- (A) Snap ring
- (B) Space ring

8) Remove the armature from end frame.

9) Remove the screws.

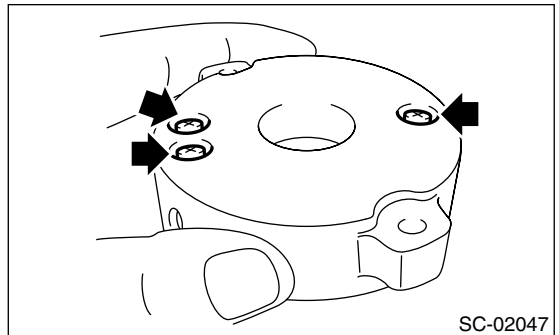

10) Remove the brush holder assembly from end frame.

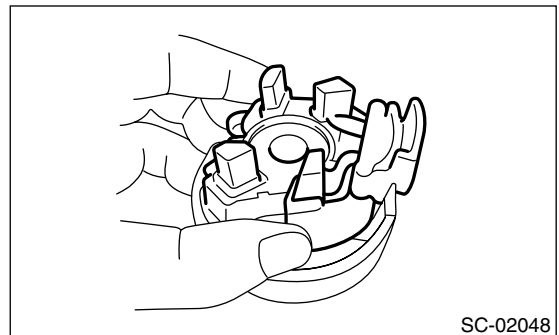

# Starter

## STARTING/CHARGING SYSTEMS

11) Remove the yoke from front bracket.

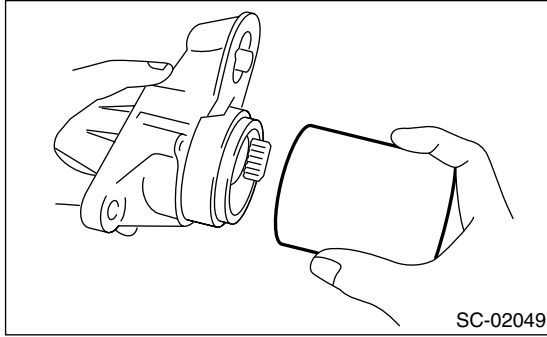

12) Remove the armature plate from the yoke.

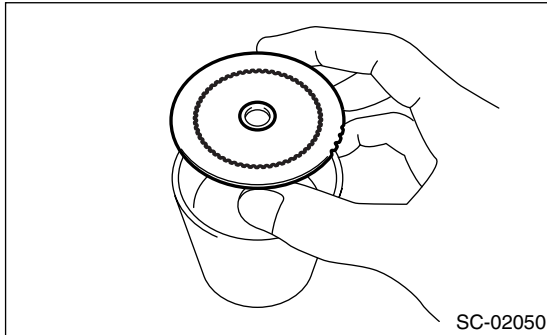

13) Remove the rubber seal and planetary gear.

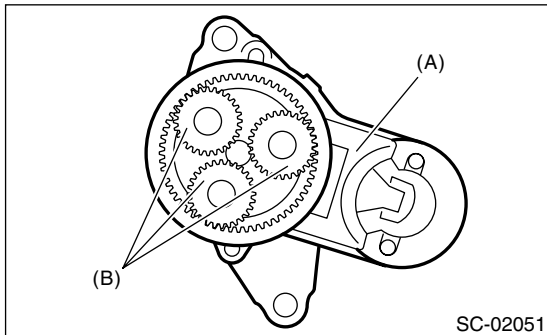

- (A) Rubber seal
- (B) Planetary gear

14) Remove the shaft assembly, overrunning clutch and lever from front bracket as a unit.

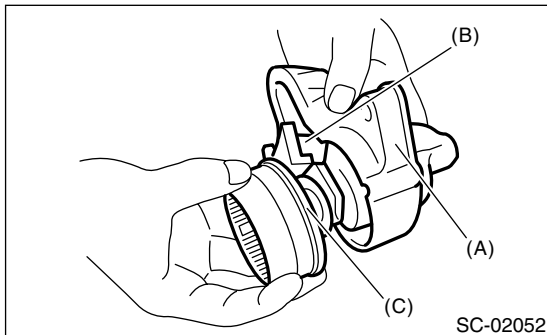

- (A) Front bracket
- (B) Lever
- (C) Shaft ASSY

15) Use the following procedures to remove the overrunning clutch from the shaft assembly.

- (1) Remove the stopper from snap ring by lightly tapping the stopper with an appropriate tool (such as a fit socket wrench).
- (2) Remove the snap ring, stopper and clutch from shaft.

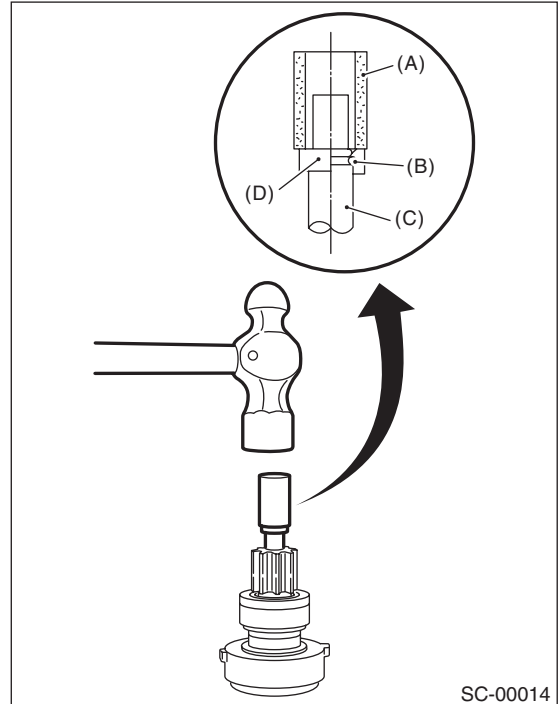

- (A) Socket wrench
- (B) Snap ring
- (C) Shaft
- (D) Stopper

16) Remove the snap ring.

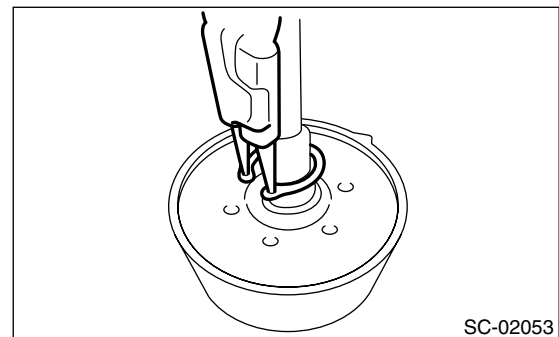

- 17) Remove the shock absorber bearing, wave washer and internal gear from shaft.

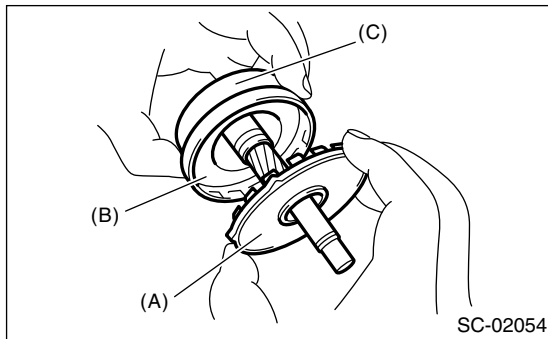

- (A) Shock absorber bearing  
 (B) Wave washer  
 (C) Internal gear

- 18) Remove the front bearing from front bracket.  
 (1) Set an appropriate tool ( $\phi 13$  mm) to front bearing.  
 (2) Using a press, remove the front bearing.

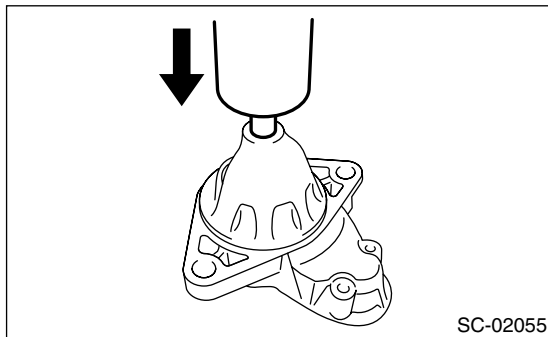

- 19) Remove the oilless bearing from shock absorber bearing.  
 (1) Set an appropriate tool ( $\phi 20$  mm) to oilless bearing.  
 (2) Using a press, remove the oilless bearing.

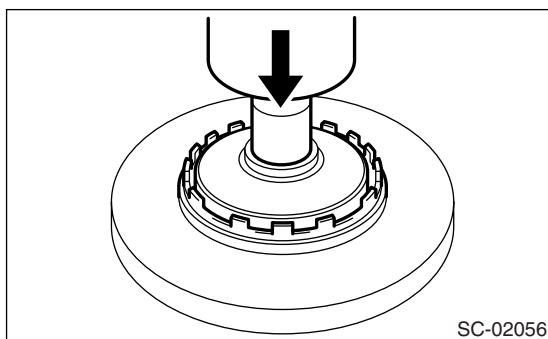

- 20) Remove the rear bearing from end frame.  
 (1) Set an appropriate tool ( $\phi 16$  mm) to rear bearing.  
 (2) Using a press, remove the rear bearing.

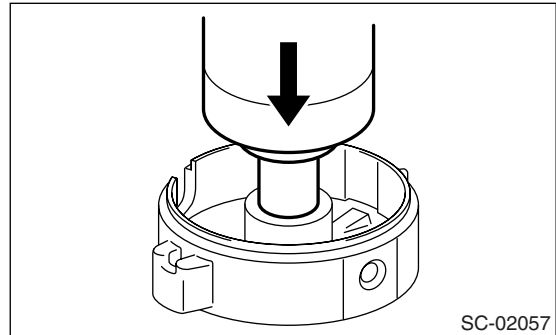

### D: ASSEMBLY

- 1) Press-fit the rear bearing into end frame.  
 (1) Set an appropriate tool ( $\phi 22$  mm) to rear bearing.  
 (2) Press-fit the rear bearing using a press.

#### NOTE:

- Use a new bearing.
- Use a flat base.
- Press-fit the bearing outer ring until it contact to the base bottom.

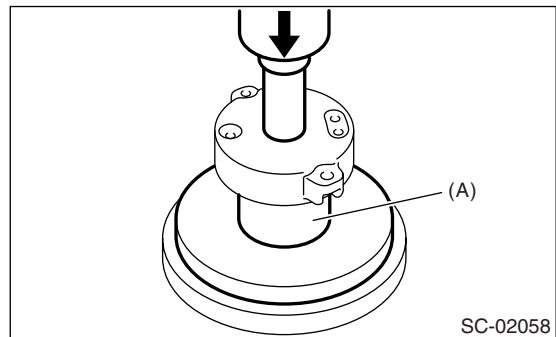

- (A) Base

# Starter

## STARTING/CHARGING SYSTEMS

2) Press-fit the oilless bearing into shock absorber bearing.

(1) Set an appropriate tool ( $\phi 20$  mm) to oilless bearing.

(2) Press-fit the oilless bearing using a press.

### NOTE:

- Use a new bearing.
- Use a flat base.
- Press-fit the bearing outer ring until it contact to the base bottom.

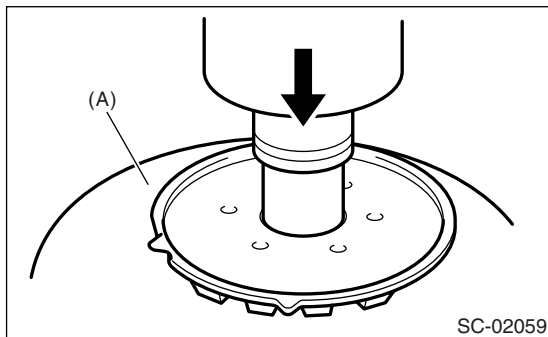

(A) Base

3) Press-fit the front bearing into front bracket.

(1) Set the front bearing into front bracket.

(2) Set an appropriate tool (2.0-mm thickness plate) to front bracket, and press-fit the front bearing using a press.

### NOTE:

- Use a new bearing.
- Measure the protrusion of front bearing after press-fitting, to check if it is within standard value.

### Standard

**2.0 — 2.4 mm (0.0787 — 0.0945 in)**

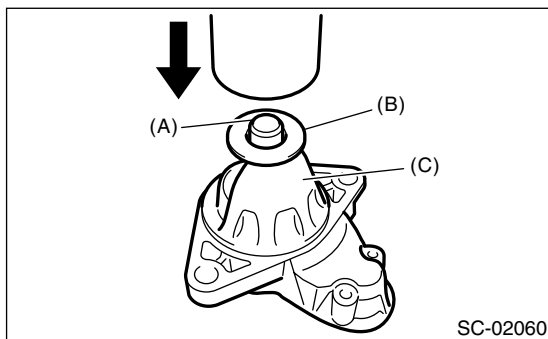

- (A) Front bearing
- (B) Plate
- (C) Front bracket

4) Assemble the internal gear and wave washer to shock absorber bearing.

### NOTE:

Align with the claw position of shock absorber bearing to install internal gear.

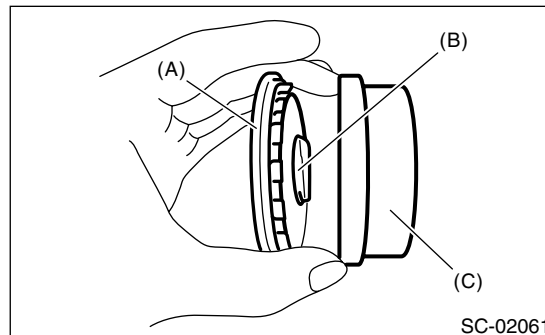

- (A) Shock absorber bearing
- (B) Wave washer
- (C) Internal gear

5) Assemble the washer and internal gear to shaft.

### NOTE:

Apply grease to the both sides of the shaft spline and washer.

### Grease:

**DENSO HL50**

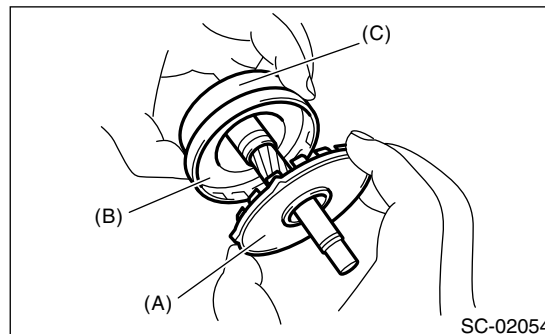

- (A) Shock absorber bearing
- (B) Wave washer
- (C) Internal gear

6) Assemble the snap ring.

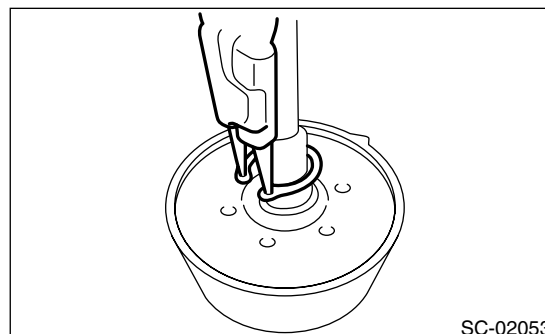

7) Assemble the overrunning clutch to shaft.

**NOTE:**

Apply grease to the stop ring entire perimeter.

**Grease:**

**DENSO HL50**

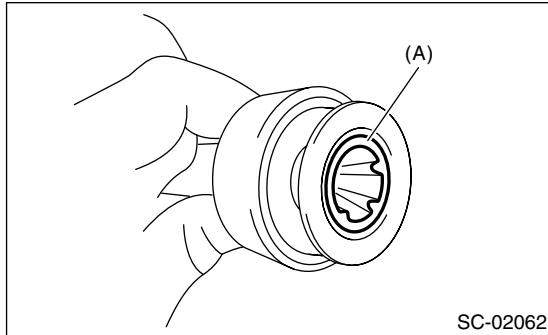

(A) Stop ring

8) Install the stopper to shaft as follows:

(1) Insert the snap ring into the shaft groove by lightly tapping it with an appropriate tool (such as a fit socket wrench).

**NOTE:**

Use new snap rings.

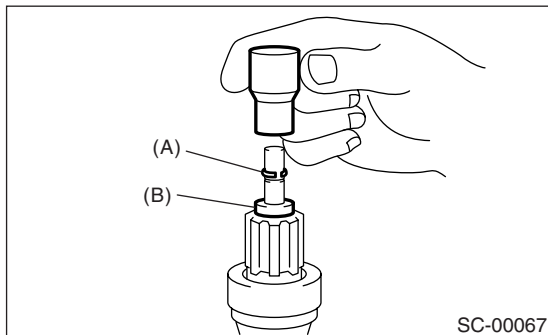

(A) Snap ring

(B) Stopper

(2) Press-fit the stopper to snap ring using a press.

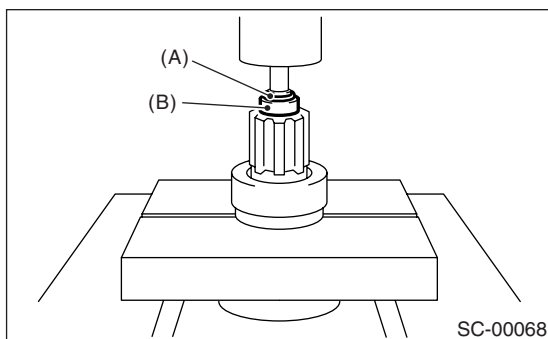

(A) Snap ring

(B) Stopper

9) Install the shaft assembly to front bracket.

(1) Apply grease to the sliding part (A) of lever pin and the pole piece (B) of arm.

**Grease:**

**DENSO HL50**

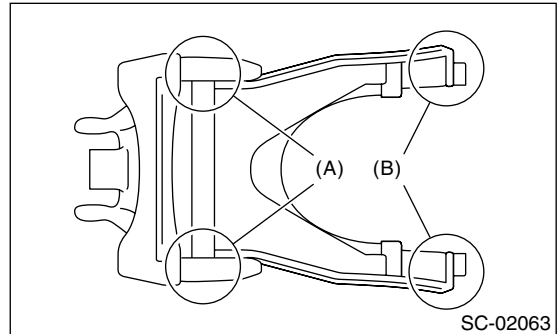

(2) Insert the lever arm into the position on overrunning clutch as shown in the figure.

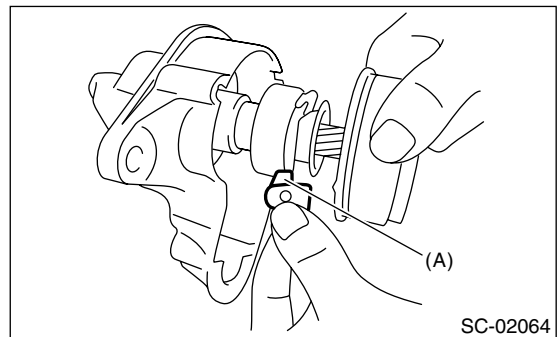

(A) Lever

(3) Align the shaft assembly to the position on front bracket as shown in the figure.

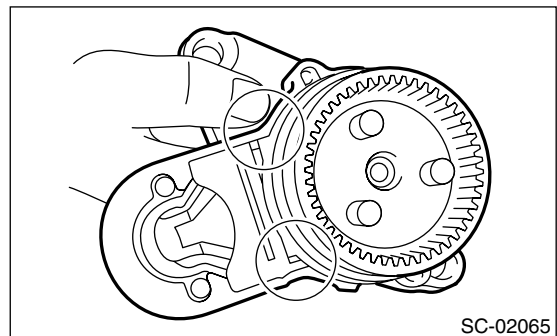

# Starter

## STARTING/CHARGING SYSTEMS

10) Install the rubber seal.

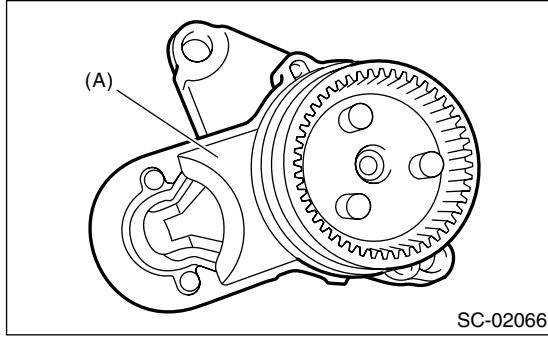

(A) Rubber seal

11) Install the planetary gear.

(1) Apply a grease to the pin (A) and bushing (B).

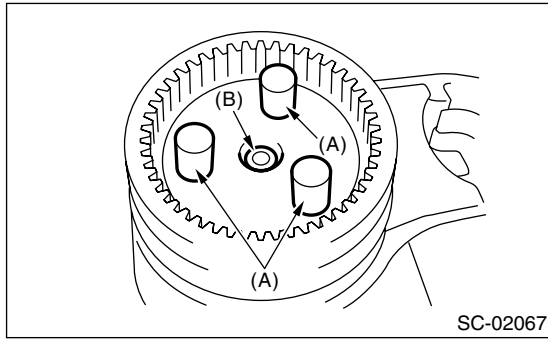

(2) Assemble the planetary gear to pin.

(3) Apply grease to the planetary gear clearance (A) and pin upper part (B).

NOTE:

- Apply grease so that it contacts each gear.
- be careful not to allow dirt to get in.

**Grease:**

**DENSO HL50**

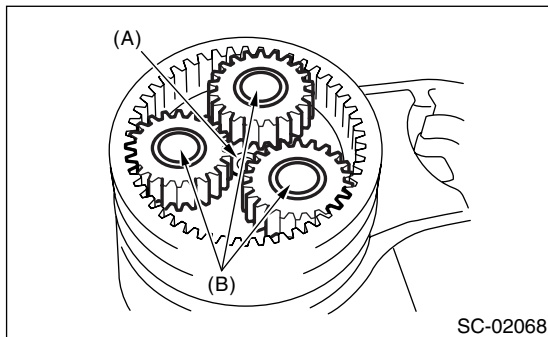

12) Assemble the brush assembly to end frame.

NOTE:

- Be careful not to allow grease to get on brush.
- Align the rubber seal part with end frame groove.

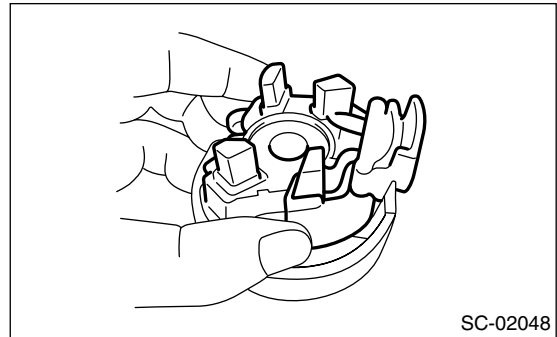

**Tightening torque:**

**1.4 N·m (0.14 kgf·m, 1.03 ft·lb)**

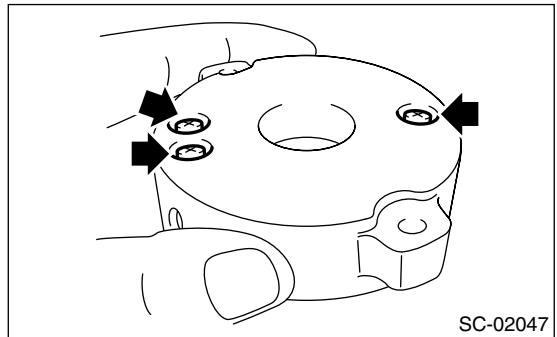

13) Install the armature to end frame.

NOTE:

- Apply grease to the rear bearing inner circumference.
- Be careful not to allow grease to attach to commutator.

**Grease:**

**DENSO HL50**

14) Set the space ring, then assemble the snap ring.

**NOTE:**

- Use new snap rings.
- Check the dimension of (A) in the figure after assembling snap ring. If it exceeds 5.0 mm (0.20 in), assemble a new snap ring again.

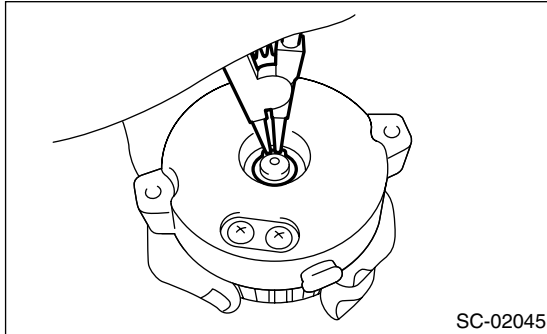

SC-02045

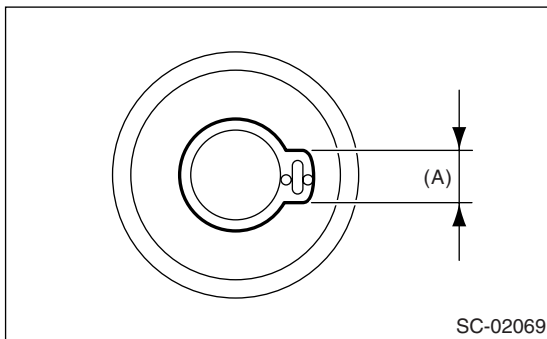

SC-02069

15) Install the end frame cover.

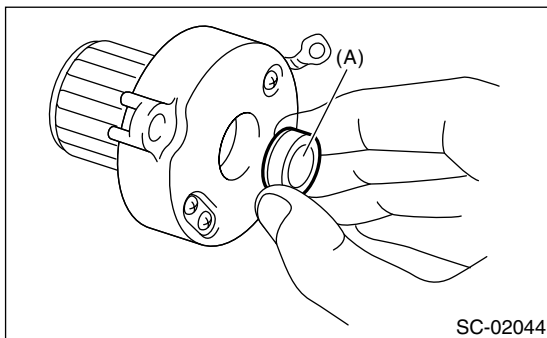

SC-02044

(A) End frame cover

16) Assemble the armature plate to yoke.

**NOTE:**

- Align the rotation stopper of armature plate with the drive out part of yoke inner circumference.

- Be careful of the assembly direction of armature plate.

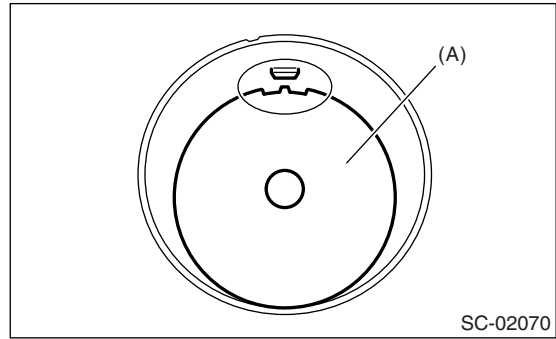

SC-02070

(A) Armature plate

17) Assemble the armature to yoke.

**NOTE:**

- Be careful not to allow armature plate to move. It is recommendable to support with cylindrical pipe as shown in the figure.
- Align the positions of cutout portion of yoke with the rubber part of end frame.
- Be careful not to damage the magnet.

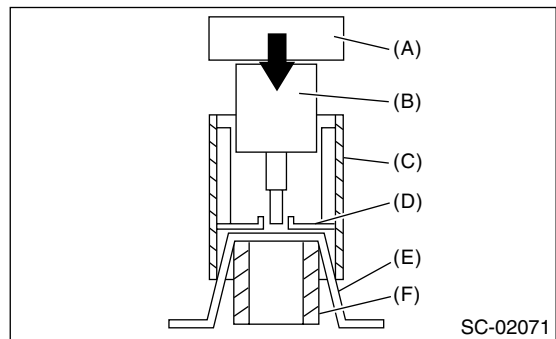

SC-02071

- (A) End frame
- (B) Armature
- (C) Yoke
- (D) Armature plate
- (E) Cloth
- (F) Pipe

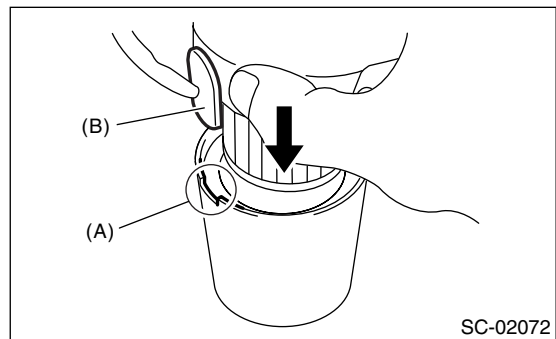

SC-02072

- (A) Cutout portion of yoke
- (B) Rubber part



# Starter

## STARTING/CHARGING SYSTEMS

18) Assemble the yoke to front bracket.

**NOTE:**

- Apply grease to the end surface of yoke (mating surface with front bracket).
- Align the drive out position of yoke outer perimeter with the cutout portion of front bracket.

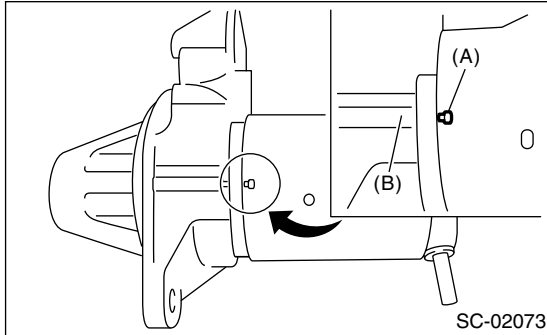

- (A) Drive out  
(B) Cutout

19) Tighten the through bolts on both sides.

**Tightening torque:**

**6 N·m (0.6 kgf·m, 4.4 ft·lb)**

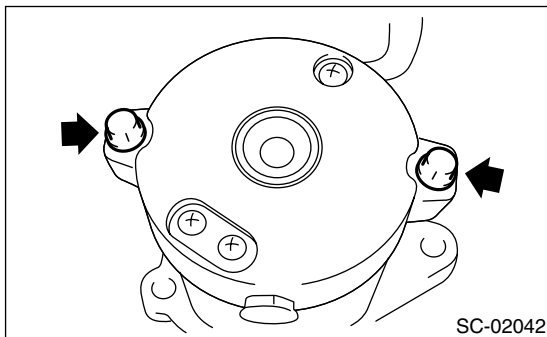

20) Install the rear cover.

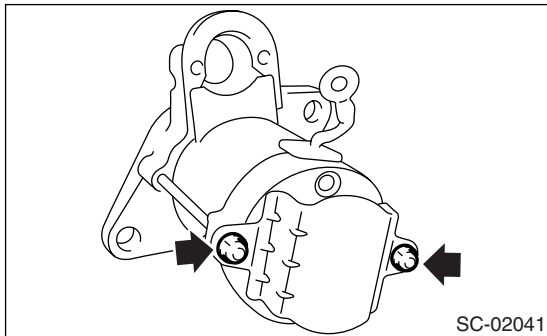

21) Install the magnet switch assembly to front bracket.

(1) Assemble the plunger hook to lever.

**NOTE:**

Apply grease to the plunger hook and sleeve inner circumference.

**Grease:**

**DENSO HL50**

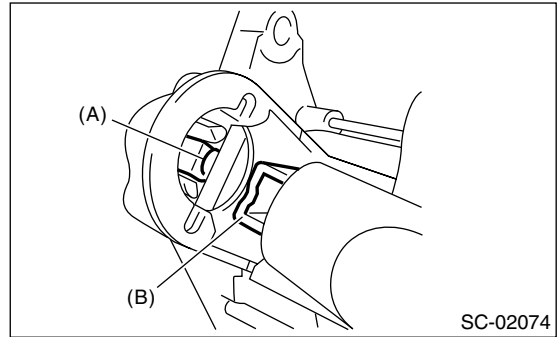

- (A) Lever  
(B) Plunger hook

(2) Assemble the plunger spring and magnet switch to front bracket.

**NOTE:**

Apply grease to the end surface of magnet switch as shown in the figure.

**Grease:**

**DENSO HL50**

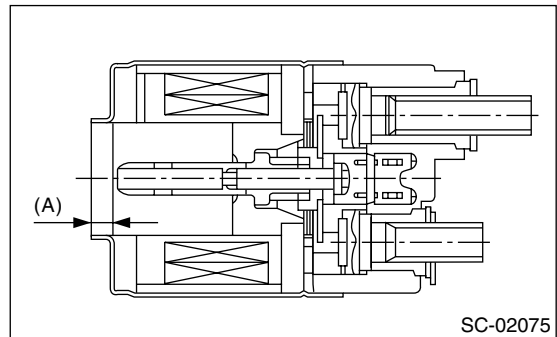

- (A) 5 mm

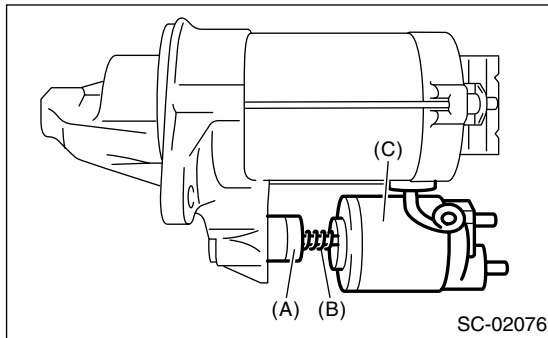

- (A) Plunger
- (B) Plunger spring
- (C) Magnet switch

(3) Tighten the bolt.

**Tightening torque:**  
**7.5 N·m (0.8 kgf·m, 5.5 ft·lb)**

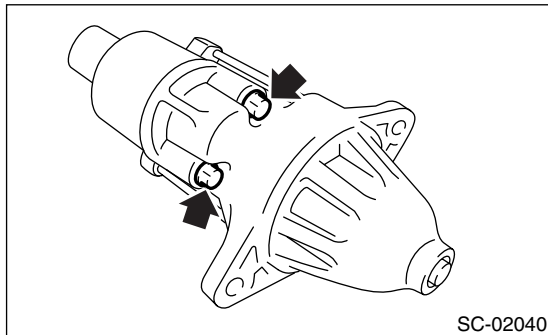

22) Connect the harness to terminal M of magnet switch assembly.

**Tightening torque:**  
**10 N·m (1.0 kgf·m, 7.4 ft·lb)**

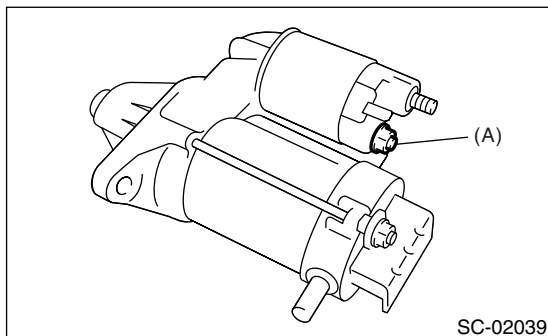

- (A) Terminal M

## E: INSPECTION

### 1. ARMATURE

1) Check the commutator for any sign of burns of rough surfaces or stepped wear. If it has minor wear, correct it by using sand paper (#300).

2) Run-out test

Check for run-out on the commutator. If excessive, replace it.

**Commutator run-out:**

**Standard**

**3.1 mm (0.1220 in)**

**Service limit**

**3.8 mm (0.1496 in) or less**

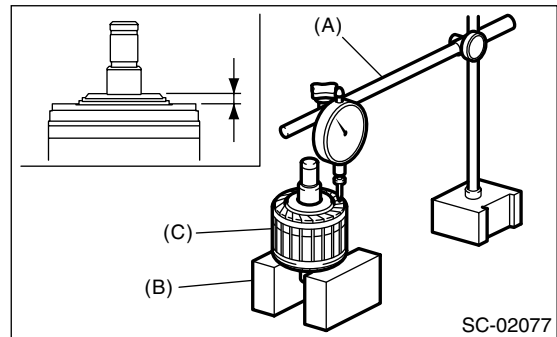

- (A) Dial gauge
- (B) Block
- (C) Armature

3) Armature short-circuit test

Place the armature on the growler tester to check for short circuits. Hold an iron sheet (thickness gauge, etc.) against the armature core while slowly rotating the armature. If the circuit of the armature is shorted, the steel seat will vibrate, causing it to move towards the core. When the steel seat has moved or vibrated, replace or repair the armature with the shorted circuit.

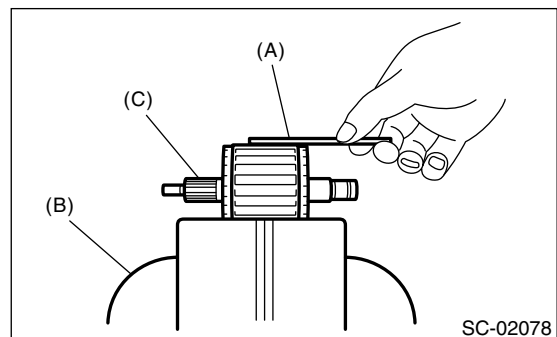

- (A) Iron sheet (thickness gauge etc.)
- (B) Growler tester
- (C) Armature

# Starter

## STARTING/CHARGING SYSTEMS

### 4) Armature discontinuity test

Using a circuit tester, touch one probe to the Armature and the other to commutator. If there is no continuity, it is normal. If there is continuity, the armature is grounded. If grounded, replace the armature.

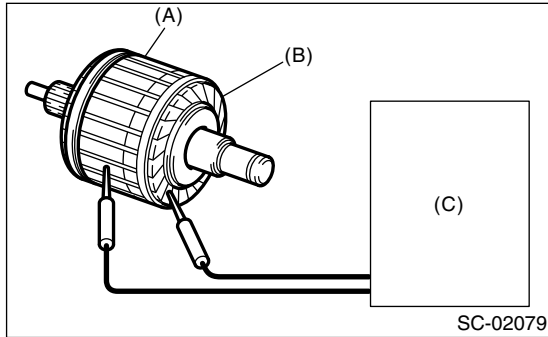

- (A) Armature
- (B) Commutator
- (C) Circuit tester

## 2. OVERRUNNING CLUTCH

Check that there is no wear or damage to the piston teeth. Replace if it is damaged. If it rotates smoothly when rotated in the correct direction (counterclockwise) and does not return to the other direction, it is normal.

### CAUTION:

To prevent spilling of grease, do not clean the overrunning clutch with oil.

## 3. BRUSH AND BRUSH HOLDER

### 1) Brush length

Measure the length of the brush. If it exceeds service limits, replace it. Replace if there is abnormal wear or cracks.

#### Brush length:

##### Standard

9.0 mm (0.354 in)

##### Service limit

6.0 mm (0.236 in)

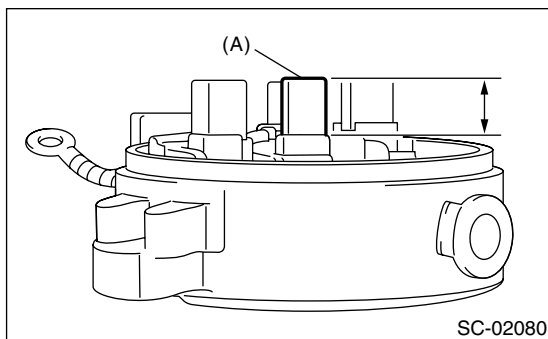

- (A) Brush

### 2) Brush movement

Check that the brush moves smoothly in the brush holder.

### 3) Brush holder discontinuity test

Using a circuit tester, bring one probe into contact with positive side brush holder and the other with negative side brush holder.

If there is no continuity, it is normal.

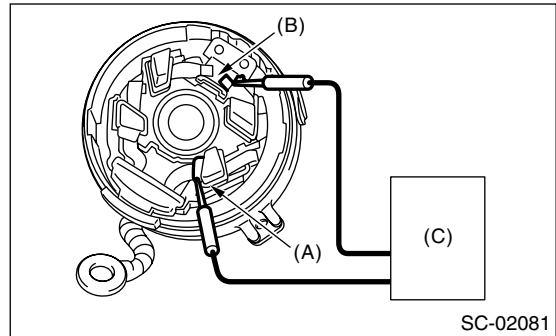

- (A) Positive side
- (B) Negative side
- (C) Circuit tester

## 4. SWITCH ASSEMBLY

### 1) Return spring check

Make sure the plunger returns to its original position immediately after pressed-in then released.

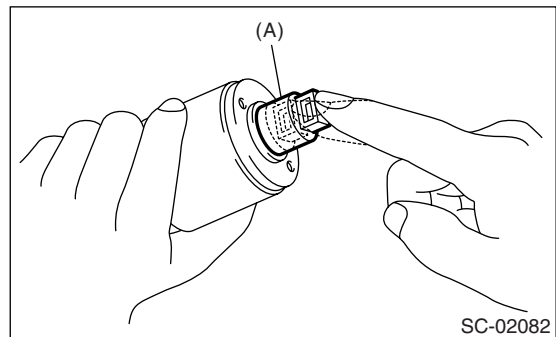

- (A) Plunger

### 2) Magnet switch continuity test

Be sure there is continuity between the terminals S and M, and between terminal S and ground. Use a circuit tester.

Also check to be sure there is no continuity between terminal M and B.

#### Terminal/Resistance:

**S — M/1  $\Omega$  or less**

**S — Ground/1  $\Omega$  or less**

**M — B/1 M $\Omega$  or more**

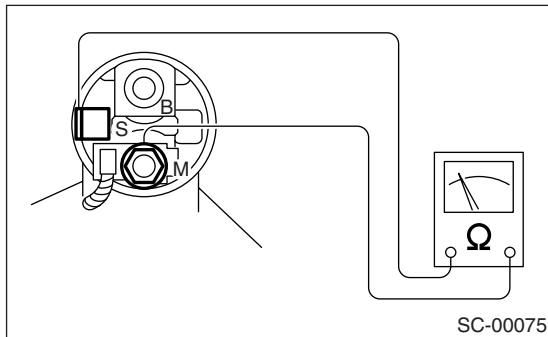

### 5. FRONT BEARING

Check the front bearing to make sure there are no damage or rust.

Also, insert the shaft into front bearing to make sure the front bearing rotates smoothly when the shaft is rotated.

Replace the front bearing if faulty.

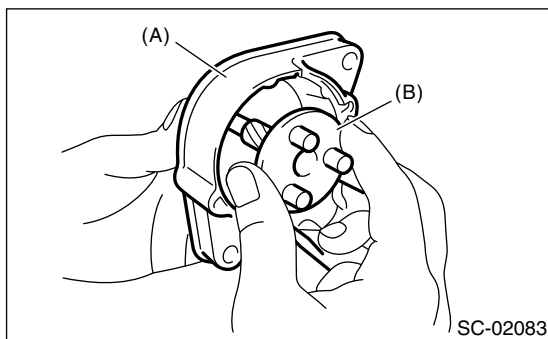

(A) Front bracket

(B) Shaft

### 6. SHOCK ABSORBER BEARING CLEARANCE

Measure the outside (A) diameter of sliding part for shaft shock absorber bearing.

Then, measure the inside (B) diameter of shock absorber bearing, and calculate the clearance.

If it exceeds the service limit, replace the oilless bearing or shaft.

#### Shock absorber bearing sliding part:

**Standard**

**18 mm (0.709 in)**

#### Clearance:

**Standard**

**0.03 — 0.061 mm (0.001 — 0.0024 in)**

**Service limit**

**0.1 mm (0.003 in)**

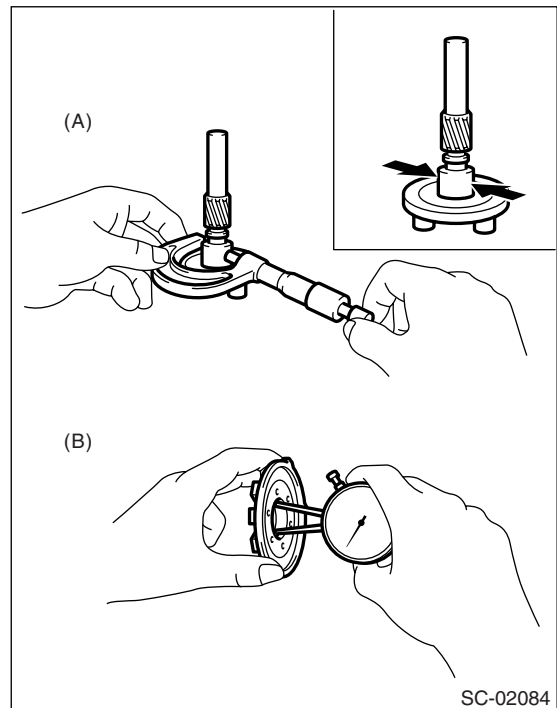

### 7. REAR BEARING

Check the rear bearing, and replace the rear bearing if there are damage, lock or rust.

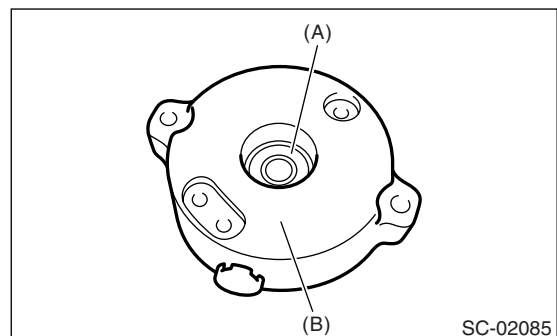

(A) Bearing

(B) End frame

# Starter

## STARTING/CHARGING SYSTEMS

### 8. PLANETARY GEAR BUSHING

Measure the outer diameter (A) of pin which is press-fitted into shaft flange.

Then, measure the inner diameter (B) of planetary gear bushing, and calculate the clearance.

If it exceeds the service limit, replace the planetary gear or shaft.

#### Clearance:

##### Standard

0.035 — 0.065 mm (0.001 — 0.0025 in)

##### Service limit

0.1 mm (0.003 in)

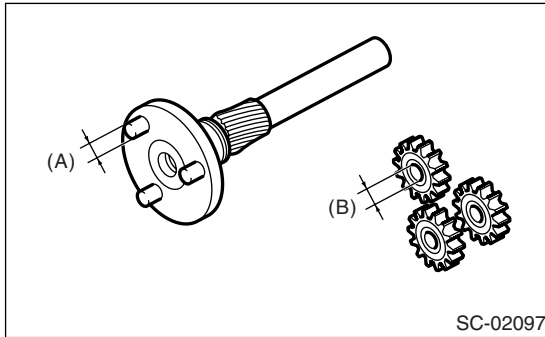

### 9. SWITCH ASSEMBLY OPERATION

#### NOTE:

Test period of each test must be within short time (3 — 5 seconds).

#### 1) Vacuum test

Disconnect the harness from terminal M and connect it as shown in the figure. Make sure the pinion gear sticks out.

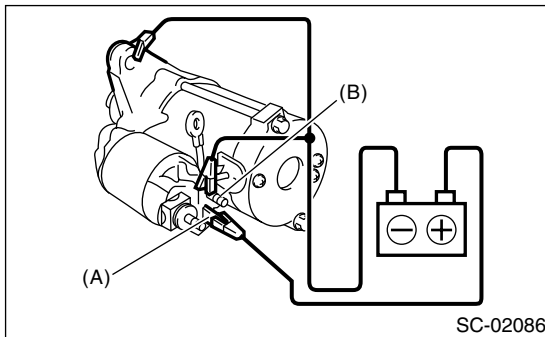

(A) Terminal S

(B) Terminal M

#### 2) Hold test

Make sure the pinion gear remains stick out even after disconnecting terminal M in the above condition.

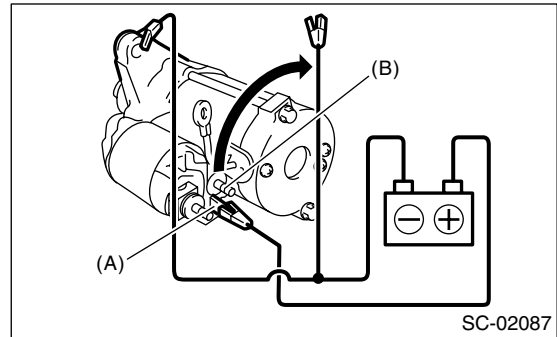

(A) Terminal S

(B) Terminal M

#### 3) Return test

Connect the positive terminal to terminal S and the negative terminal to terminal M and starter body to pull the pinion gear at the main contact point. Make sure the pinion gear returns to its original position when the terminal S is disconnected.

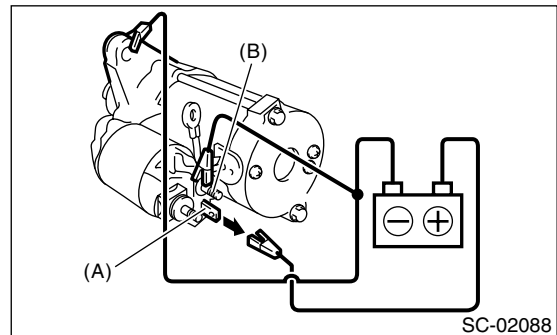

(A) Terminal S

(B) Terminal M

## 10.PERFORMANCE TEST

The starter should be submitted to performance tests whenever it has been overhauled, to assure its satisfactory performance when installed on the engine.

Three performance tests, no-load test, load test, and lock test, are presented here; however, if the load test and lock test cannot be performed, carry out at least the no-load test.

For these performance tests, use the circuit shown in figure.

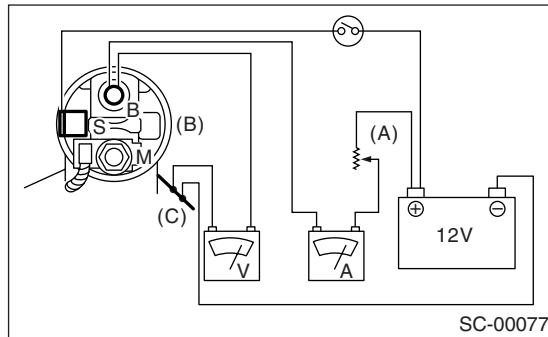

- (A) Variable resistance
- (B) Starter body
- (C) Magnetic switch

### 1) No-load test

With switch on, adjust the variable resistance until the voltage is 11 V, read the value of ammeter to measure rotating speed. Compare these values with the standard.

#### **No-load test (standard):**

##### **Voltage/Current**

**MT model**

**Max. 11 V/90 A or less**

**AT model**

**Max. 11 V/90 A or less**

##### **Rotating speed**

**MT model**

**1,820 rpm or more**

**AT model**

**1,720 rpm or more**

### 2) Load test

Apply the specified braking torque to starter. The condition is satisfactory if the current draw and rotating speed are within specifications.

#### **Load test (standard):**

##### **Voltage/Load**

**MT model**

**8 V/7.76 N·m (0.79 kgf-m, 5.7 ft-lb)**

**AT model**

**8 V/12.78 N·m (1.30 kgf-m, 9.4 ft-lb)**

##### **Current/Speed**

**MT model**

**280 A/900 rpm or more**

**AT model**

**370 A/850 rpm or more**

### 3) Lock test

With the starter stalled, or not rotating, measure the torque developed and current draw when the voltage is adjusted to standard voltage.

#### **Lock test (standard):**

##### **Voltage/Current**

**MT model**

**3 V/900 A or less**

**AT model**

**3 V/900 A or less**

##### **Torque**

**MT model**

**13.62 N·m (1.38 kgf-m, 10.0 ft-lb)**

**AT model**

**15.42 N·m (1.57 kgf-m, 11.3 ft-lb)**