



2010 LEGACY/OUTBACK Owner's Manual



SUBARU

Foreword

Congratulations on choosing a SUBARU vehicle. This Owner's Manual has all the information necessary to keep your SUBARU in excellent condition and to properly maintain the emission control system for minimizing emission pollutants. We urge you to read this manual carefully so that you may understand your vehicle and its operation. For information not found in this Owner's Manual, such as details concerning repairs or adjustments, please contact the SUBARU dealer from whom you purchased your SUBARU or the nearest SUBARU dealer.

The information, specifications and illustrations found in this manual are those in effect at the time of printing. FUJI HEAVY INDUSTRIES LTD. reserves the right to change specifications and designs at any time without prior notice and without incurring any obligation to make the same or similar changes on vehicles previously sold. This Owner's Manual applies to all models and covers all equipment, including factory installed options. Some explanations, therefore may be for equipment not installed in your vehicle.

Please leave this manual in the vehicle at the time of resale. The next owner will need the information found herein.

FUJI HEAVY INDUSTRIES LTD., TOKYO, JAPAN

 **SUBARU** is a registered trademark of FUJI HEAVY INDUSTRIES LTD.

© Copyright 2009 FUJI HEAVY INDUSTRIES LTD.

This manual describes the following types of the Legacy series.

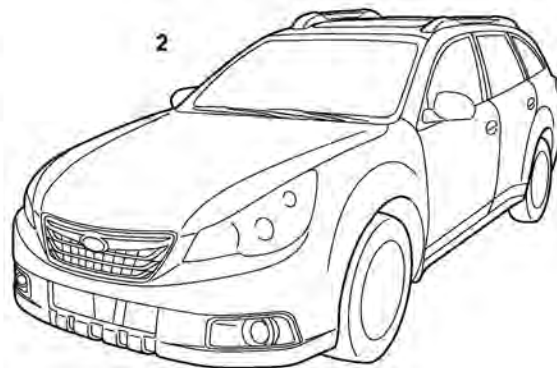
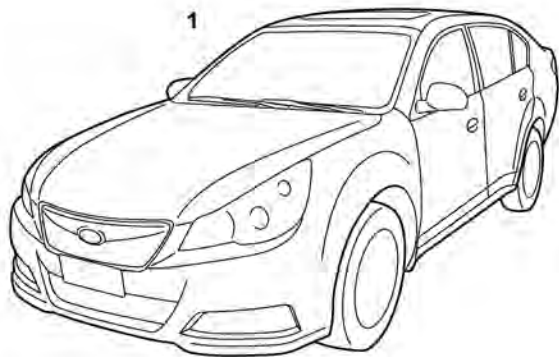

000611

- 1) Legacy
- 2) Outback

Warranties

■ Warranties for U.S.A.

All SUBARU vehicles distributed by Subaru of America, Inc. and sold at retail by an authorized SUBARU dealer in the United States come with the following warranties:

- SUBARU Limited Warranty
- Emission Control Systems Warranty
- Emissions Performance Warranty

All warranty information, including details of coverage and exclusions, is in the "Warranty and Maintenance Booklet". Please read these warranties carefully.

■ Warranties for Canada

All SUBARU vehicles distributed by Subaru Canada, Inc. and sold at retail by an authorized SUBARU dealer in Canada come with the following warranties:

- SUBARU Limited Warranty
- Anti-Corrosion Warranty
- Emission Control Warranty

All warranty information, including details of coverage and exclusions, is in the "Warranty and Service Booklet". Please read these warranties carefully.

How to use this Owner's Manual

■ Using your Owner's Manual

Before you operate your vehicle, carefully read this manual. To protect yourself and extend the service life of your vehicle, follow the instructions in this manual. Failure to observe these instructions may result in serious injury and damage to your vehicle.

This manual is composed of fourteen chapters. Each chapter begins with a brief table of contents, so you can usually tell at a glance if that chapter contains the information you want.

Chapter 1: Seat, seatbelt and SRS airbags

This chapter informs you how to use the seat and seatbelt and contains precautions for the SRS airbags.

Chapter 2: Keys and doors

This chapter informs you how to operate the keys, locks and windows.

Chapter 3: Instruments and controls

This chapter informs you about the operation of instrument panel indicators and how to use the instruments and other switches.

Chapter 4: Climate control

This chapter informs you how to operate the climate control.

Chapter 5: Audio

This chapter informs you how to operate your audio system.

Chapter 6: Interior equipment

This chapter informs you how to operate interior equipment.

Chapter 7: Starting and operating

This chapter informs you how to start and operate your SUBARU.

Chapter 8: Driving tips

This chapter informs you how to drive your SUBARU in various conditions and explains some safety tips on driving.

Chapter 9: In case of emergency

This chapter informs you what to do if you have a problem while driving, such as a flat tire or engine overheating.

Chapter 10: Appearance care

This chapter informs you how to keep your SUBARU looking good.

Chapter 11: Maintenance and service

This chapter informs you when you need to take your SUBARU to the dealer for scheduled maintenance and informs you how to keep your SUBARU running properly.

Chapter 12: Specifications

This chapter informs you about the dimensions and capacities of your SUBARU.

Chapter 13: Consumer information and Reporting safety defects

This chapter informs you about Tire information, Uniform tire quality grading standards and Reporting safety defects.

Chapter 14: Index

This is an alphabetical listing of all that's in this manual. You can use it to quickly find something you want to read.

■ Safety warnings

You will find a number of WARNINGS, CAUTIONS and NOTES in this manual.

These safety warnings alert you to potential hazards that could result in injury to you or others.

Please read these safety warnings as well as all other portions of this manual carefully in order to gain a better understanding of how to use your SUBARU vehicle safely.

WARNING

A WARNING indicates a situation in which serious injury or death could result if the warning is ignored.

CAUTION

A CAUTION indicates a situation in which injury or damage to your vehicle, or both, could result if the caution is ignored.

NOTE

A NOTE gives information or suggestions how to make better use of your vehicle.

■ Safety symbol



You will find a circle with a slash through it in this manual. This symbol means "Do not", "Do not do this", or "Do not let this happen", depending upon the context.

■ Abbreviation list

You will find several abbreviations in this manual. The meanings of the abbreviations are shown in the following list.









| Abbreviation | Meaning |
|--------------|---------------------------------------|
| A/C | Air conditioner |
| A/ELR | Automatic/Emergency locking retractor |
| ABS | Anti-lock brake system |
| AKI | Anti knock index |
| ALR | Automatic locking retractor |
| AT | Automatic transmission |
| ATF | Automatic transmission fluid |
| AWD | All-wheel drive |
| CVT | Continuously variable transmission |
| DRL | Daytime running light |
| EBD | Electronic brake force distribution |
| ELR | Emergency locking retractor |
| FWD | Front-wheel drive |
| GAW | Gross axle weight |
| GAWR | Gross axle weight rating |
| GPS | Global positioning system |
| GVW | Gross vehicle weight |
| GVWR | Gross vehicle weight rating |











| Abbreviation | Meaning |
|--------------|--|
| HID | High intensity discharge |
| INT | Intermittent |
| LATCH | Lower anchors and tethers for children |
| LED | Light emitting diode |
| LSD | Limited slip differential |
| MIL | Malfunction indicator lamp |
| MMT | Methylcyclopentadienyl manganese tricarbonyl |
| MT | Manual transmission |
| OBD | On-board diagnostics |
| SI-DRIVE | SUBARU Intelligent Drive |
| SRS | Supplemental restraint system |
| TIN | Tire identification number |
| TPMS | Tire pressure monitoring system |
| VDC | Vehicle dynamics control |

Vehicle symbols











There are some of the symbols you may see on your vehicle.



For warning and indicator lights, refer to “Warning and indicator lights”  19.

| Mark | Name |
|---|---------------------------------------|
|  | WARNING |
|  | CAUTION |
|  | Passengers' windows lock |
|  | Fuel |
|  | Front fog lights |
|  | Hazard warning flasher |
|  | Seat heater |
|  | Child restraint lower anchorages |
|  | Child restraint top tether anchorages |

| Mark | Name |
|---|--|
|  | Horn |
|  | Windshield wiper and washer |
|  | Rear window wiper |
|  | Rear window washer |
|  | Lights |
|  | Tail lights, license plate light and instrument panel illumination |
|  | Headlights |
|  | Turn signal |
|  | Illumination brightness |
|  | Engine hood |
|  | Trunk lid (Legacy) |

– CONTINUED –

| Mark | Name |
|---|--|
|  | Fan speed |
|  | Instrument panel outlets |
|  | Instrument panel outlets and foot outlets |
|  | Foot outlets |
|  | Windshield defroster and foot outlets |
|  | Windshield defroster |
|  | Rear window defogger/Outside mirror defogger/Windshield wiper deicer |
|  | Air recirculation |
|  | Outside air |
|  | Engine oil |
|  | Washer |

| Mark | Name |
|---|---|
|  | Door lock (transmitter) |
|  | Door unlock (transmitter) |
|  | Trunk lid (Legacy) or rear gate (Outback) (transmitter) |

Safety precautions when driving

■ Seatbelt and SRS airbag

WARNING

- All persons in the vehicle should fasten their seatbelts **BEFORE** the vehicle starts to move. Otherwise, the possibility of serious injury becomes greater in the event of a sudden stop or accident.
- To obtain maximum protection in the event of an accident, the driver and all passengers in the vehicle should always wear seatbelts when the vehicle is moving. The SRS (Supplemental Restraint System) airbag does not do away with the need to fasten seatbelts. In combination with the seatbelts, it offers the best combined protection in case of a serious accident.

Not wearing a seatbelt increases the chance of severe injury or death in a crash even when the vehicle has the SRS airbag.

- The SRS airbags deploy with considerable speed and force. Occupants who are out of proper position when the SRS airbag deploys could suffer very serious injuries. Because the SRS airbag needs enough space for deployment, the driver should always sit upright and well back in the seat as far from the steering wheel as practical while still maintaining full vehicle control and the front passenger should move the seat as far back as possible and sit upright and well back in the seat.

For instructions and precautions, carefully read the following sections.

- For the seatbelt system, refer to “Seatbelts” 1-12.
- For the SRS airbag system, refer to “*SRS airbag (Supplemental Restraint System airbag)” 1-38.

■ Child safety

WARNING

- Never hold a child on your lap or in your arms while the vehicle is moving. The passenger cannot protect the child from injury in a collision, because the child will be caught between the passenger and objects inside the vehicle.
- While riding in the vehicle, infants and small children should always be placed in the REAR seat in an infant or child restraint system which is appropriate for the child’s age, height and weight. If a child is too big for a child restraint system, the child should sit in the REAR seat and be restrained using the seatbelts. According to accident statistics, children are safer when properly restrained in the rear seating positions than in the front seating positions. Never allow a child to stand up or kneel on the seat.
- Put children in the REAR seat properly restrained at all times in a child restraint device or in a seatbelt. The SRS airbag deploys

with considerable speed and force and can injure or even kill children, especially if they are not restrained or improperly restrained. Because children are lighter and weaker than adults, their risk of being injured from deployment is greater.

- NEVER INSTALL A REARWARD FACING CHILD SAFETY SEAT IN THE FRONT SEAT. DOING SO RISKS SERIOUS INJURY OR DEATH TO THE CHILD BY PLACING THE CHILD’S HEAD TOO CLOSE TO THE SRS AIRBAG.
- Always turn the child safety locks to the “LOCK” position whenever a child rides in the rear seat. Serious injury could result if a child accidentally opened the door and fell out. Refer to “Child safety locks” 2-20.
- Always lock the passengers’ windows using the lock switch when children are riding in the vehicle. Failure to follow this procedure could result in injury to a child operating the power window. Refer to “Windows” 2-21.
- Never leave unattended children, adults or animals in the vehicle.

They could accidentally injure themselves or others through inadvertent operation of the vehicle. Also, on hot or sunny days, the temperature in a closed vehicle could quickly become high enough to cause severe or possibly fatal injuries.

- Help prevent children, adults or animals from locking themselves in the trunk. On hot or sunny days, the temperature in the trunk could quickly become high enough to cause death or serious heat-related injuries including brain damage to anyone locked inside, particularly for small children.
- When leaving the vehicle, close all windows and lock all doors. Also make certain that the trunk is closed.

For instructions and precautions, carefully read the following sections.

- For the seatbelt system, refer to “Seatbelts” ¶ 1-12.
- For the child restraint system, refer to “Child restraint systems” ¶ 1-25.
- For the SRS airbag system, refer to “*SRS airbag (Supplemental Restraint

System airbag)” ¶ 1-38.

■ Engine exhaust gas (carbon monoxide)

WARNING

- Never inhale engine exhaust gas. Engine exhaust gas contains carbon monoxide, a colorless and odorless gas which is dangerous, or even lethal, if inhaled.
- Always properly maintain the engine exhaust system to prevent engine exhaust gas from entering the vehicle.
- Never run the engine in a closed space, such as a garage, except for the brief time needed to drive the vehicle in or out of it.
- Avoid remaining in a parked vehicle for a lengthy time while the engine is running. If that is unavoidable, then use the ventilation fan to force fresh air into the vehicle.
- Always keep the front ventilator inlet grille free from snow, leaves or other obstructions to ensure that the ventilation system always works properly.

- If at any time you suspect that exhaust fumes are entering the vehicle, have the problem checked and corrected as soon as possible. If you must drive under these conditions, drive only with all windows fully open.
- Keep the trunk lid or rear gate closed while driving to prevent exhaust gas from entering the vehicle.

■ Drinking and driving

WARNING

Drinking and then driving is very dangerous. Alcohol in the bloodstream delays your reaction and impairs your perception, judgment and attentiveness. If you drive after drinking – even if you drink just a little – it will increase the risk of being involved in a serious or fatal accident, injuring or killing yourself, your passengers and others. In addition, if you are injured in the accident, alcohol may increase the severity of that injury.

Please don't drink and drive.

Drunken driving is one of the most frequent causes of accidents. Since alcohol affects all people differently, you may have consumed too much alcohol to drive safely even if the level of alcohol in your blood is below the legal limit. The safest thing you can do is never drink and drive. However if you have no choice but to drive, stop drinking and sober up completely before getting behind the wheel.

■ Drugs and driving

 **WARNING**

There are some drugs (over the counter and prescription) that can delay your reaction time and impair your perception, judgment and attentiveness. If you drive after taking them, it may increase your, your passengers' and other persons' risk of being involved in a serious or fatal accident.

If you are taking any drugs, check with your doctor or pharmacist or read the literature that accompanies the medication to determine if the drug you are taking can impair your driving ability. Do not drive

after taking any medications that can make you drowsy or otherwise affect your ability to safely operate a motor vehicle. If you have a medical condition that requires you to take drugs, please consult with your doctor.

Never drive if you are under the influence of any illicit mind-altering drugs. For your own health and well-being, we urge you not to take illegal drugs in the first place and to seek treatment if you are addicted to those drugs.

■ Driving when tired or sleepy

 **WARNING**

When you are tired or sleepy, your reaction will be delayed and your perception, judgment and attentiveness will be impaired. If you drive when tired or sleepy, your, your passengers' and other persons' chances of being involved in a serious accident may increase.

Please do not continue to drive but instead find a safe place to rest if you are tired or sleepy. On long trips, you should make periodic rest stops to refresh yourself before continuing on your journey. When possible, you should share the

driving with others.

■ Car phone/cell phone and driving

 **CAUTION**

Do not use a car phone/cell phone while driving; it may distract your attention from driving and can lead to an accident. If you use a car phone/cell phone, pull off the road and park in a safe place before using your phone. In some States/Provinces, only hands-free phones may legally be used while driving.

■ Modification of your vehicle

CAUTION

Your vehicle should not be modified other than with genuine SUBARU parts and accessories. Other types of modifications could affect its performance, safety or durability, and may even violate governmental regulations. In addition, damage or performance problems resulting from modification may not be covered under warranties.

■ Driving with pets

Unrestrained pets can interfere with your driving and distract your attention from driving. In a collision or sudden stop, unrestrained pets or cages can be thrown around inside the vehicle and hurt you or your passengers. Besides, the pets can be hurt under these situations. It is also for their own safety that pets should be properly restrained in your vehicle. Restrain a pet with a special traveling harness which can be secured to the rear seat with a seatbelt or use a pet carrier which can be secured to the rear seat by routing a seatbelt through the carrier's handle. Never restrain pets or pet carriers

in the front passenger's seat. For further information, consult your veterinarian, local animal protection society or pet shop.

■ Tire pressures

WARNING

Driving at high speeds with excessively low tire pressures can cause the tires to deform severely and to rapidly become hot. A sharp increase in temperature could cause tread separation, and destruction of the tires. The resulting loss of vehicle control could lead to an accident.

Check and, if necessary, adjust the pressure of each tire (including the spare) at least once a month and before any long journey.

Check the tire pressure when the tires are cold. Use a pressure gauge to adjust the tire pressures to the values shown on the tire placard. For detailed information, refer to "Tires and wheels"  11-35.

■ California proposition 65 warning

WARNING

Engine exhaust, some of its constituents, and certain vehicle components contain or emit chemicals known to the State of California to cause cancer and birth defects or other reproductive harm. In addition, certain fluids in vehicles and certain components of product wear contain or emit chemicals known to the State of California to cause cancer and birth defects or other reproductive harm.

Table of contents

| | |
|--|-----------|
| <i>Seat, seatbelt and SRS airbags</i> | 1 |
| <i>Keys and doors</i> | 2 |
| <i>Instruments and controls</i> | 3 |
| <i>Climate control</i> | 4 |
| <i>Audio</i> | 5 |
| <i>Interior equipment</i> | 6 |
| <i>Starting and operating</i> | 7 |
| <i>Driving tips</i> | 8 |
| <i>In case of emergency</i> | 9 |
| <i>Appearance care</i> | 10 |
| <i>Maintenance and service</i> | 11 |
| <i>Specifications</i> | 12 |
| <i>Consumer information and Reporting safety defects</i> | 13 |
| <i>Index</i> | 14 |

Illustrated index

■ Exterior

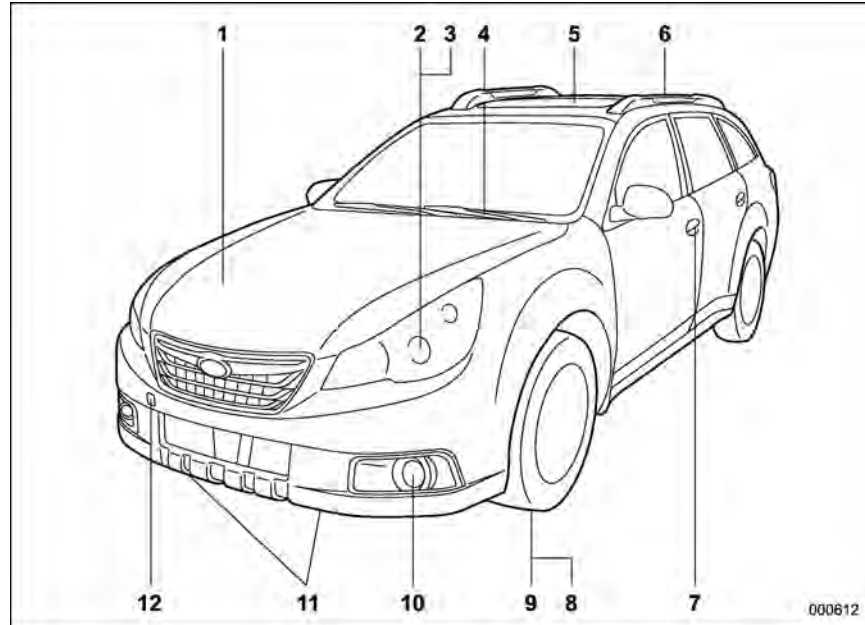

- 1) Engine hood lock release (page 11-7)
- 2) Headlight switch (page 3-27)
- 3) Bulb replacement (page 11-50)
- 4) Wiper switch (page 3-32)
- 5) Moonroof (page 2-28)
- 6) Roof rail (page 8-14)
- 7) Door locks (page 2-5)
- 8) Tire pressure (page 11-37)
- 9) Flat tires (page 9-6)
- 10) Fog light switch (page 3-30)
- 11) Tie-down hooks (page 9-13)
- 12) Towing hook (page 9-12)

000612

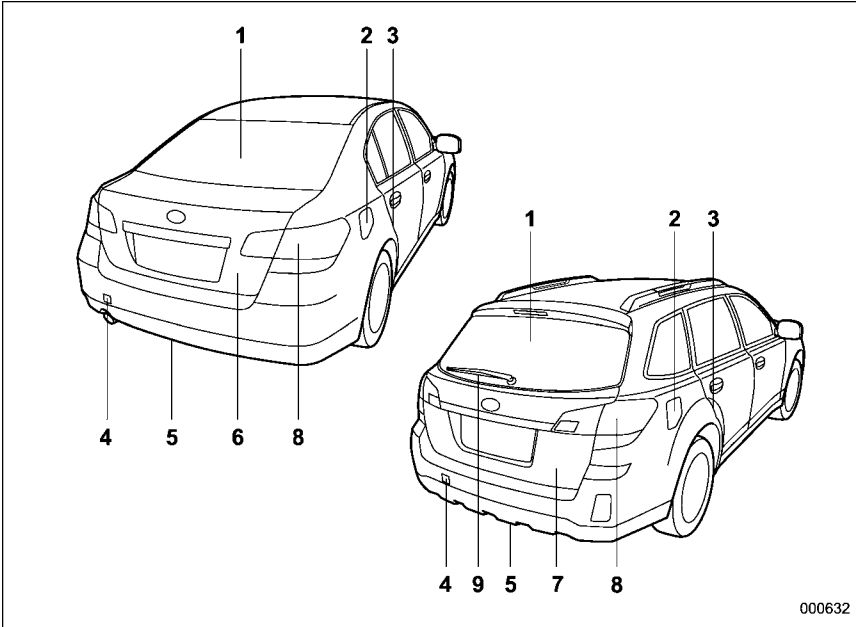

- 1) Rear window defogger button (page 3-34)
- 2) Fuel filler lid and cap (page 7-3)
- 3) Child safety locks (page 2-20)
- 4) Towing hook (page 9-12)
- 5) Tie-down hooks (page 9-13)
- 6) Trunk lid (page 2-24)
- 7) Rear gate (page 2-27)
- 8) Bulb replacement (page 11-54)
- 9) Rear wiper switch (page 3-34)

000632

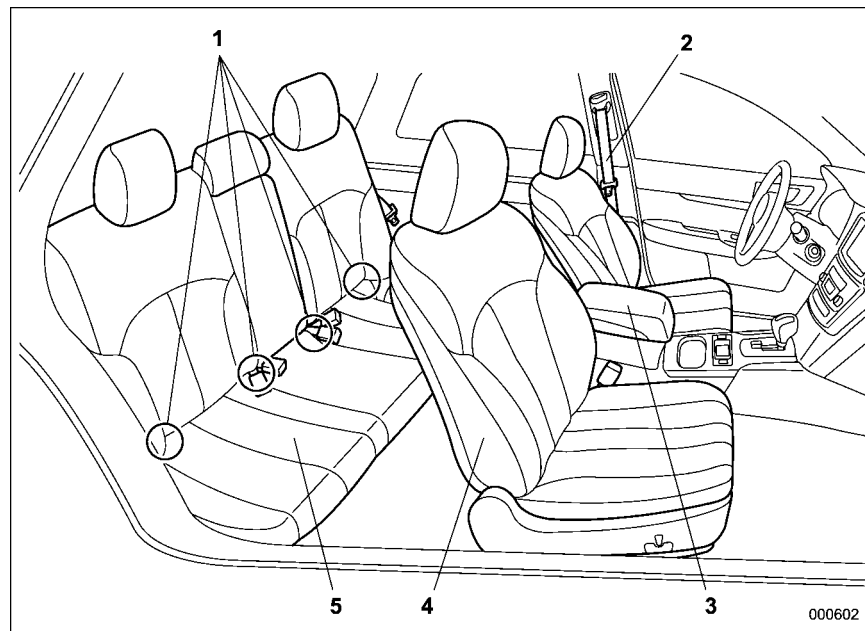
Interior**▼ Passenger compartment area**

- 1) Lower anchorages for child restraint system (page 1-33)
- 2) Seatbelt (page 1-12)
- 3) Center console (page 6-6)
- 4) Front seat (page 1-2)
- 5) Rear seat (page 1-7)

000602

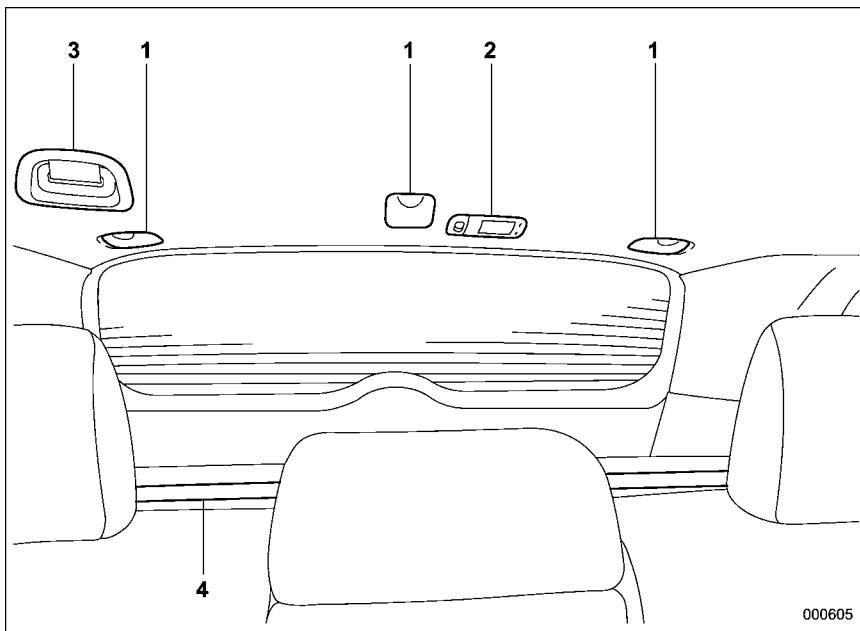

- 1) Top tether anchorages (page 1-35)
- 2) Cargo area light (page 6-3)
- 3) Rear center seatbelt (page 1-18)
- 4) Cargo area cover (page 6-15)

000605

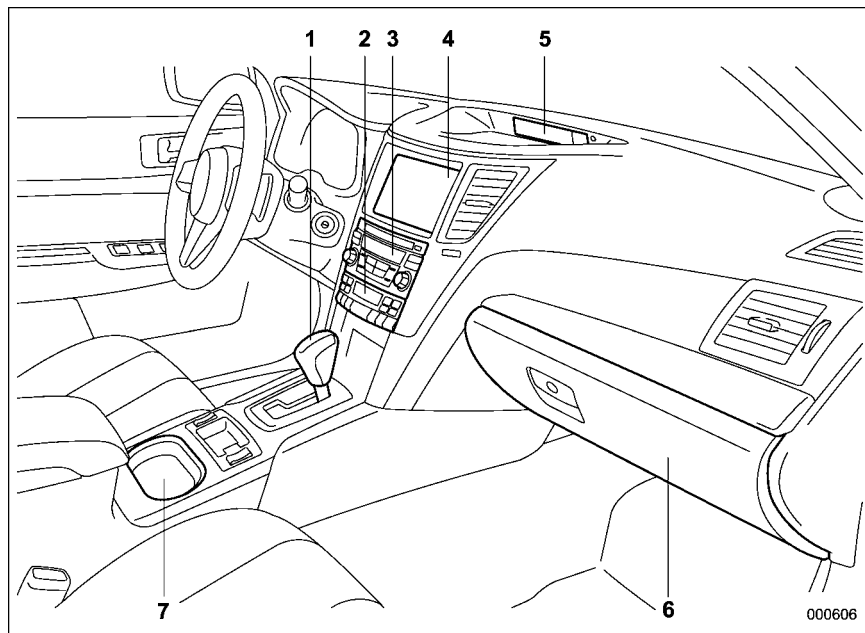

- 1) Shift lever (MT) (page 7-16)/Select lever (AT and CVT) (page 7-19)
- 2) Climate control (page 4-1)
- 3) Audio (page 5-1)
- 4) Navigation system (Refer to the Owner's Manual supplement for the navigation system)
- 5) Multi function display (page 3-24)
- 6) Glove box (page 6-6)
- 7) Cup holder (page 6-8)

000606

■ Instrument panel

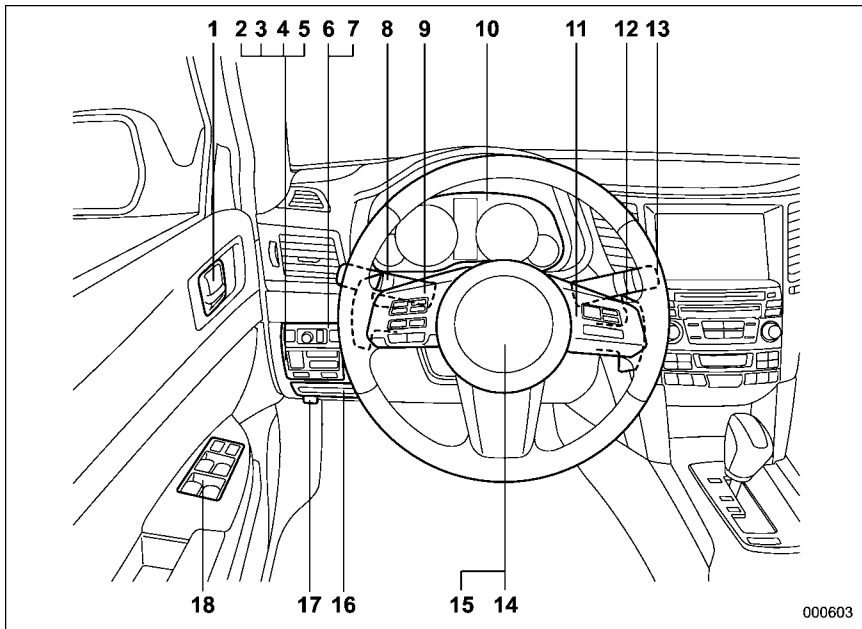

- 1) Door locks (page 2-5)
- 2) Electronic parking brake switch (page 7-34)
- 3) Hill Holder switch (page 7-35)
- 4) Trunk lid opener switch (page 2-24)
- 5) Vehicle Dynamics Control OFF switch (page 7-31)
- 6) Remote control mirror switch (page 3-38)
- 7) Illumination brightness control (page 3-30)
- 8) Light control switch (page 3-27)
- 9) Audio control buttons (page 5-30)
- 10) Combination meter (page 3-5)
- 11) Cruise control (page 7-38)
- 12) Paddle shift (page 7-21)
- 13) Wiper control lever (page 3-31)
- 14) Horn (page 3-39)
- 15) SRS airbag (page 1-38)
- 16) Fuse box (page 11-48)
- 17) Hood lock release knob (page 11-7)
- 18) Power windows (page 2-21)

■ Light control and wiper control levers/switches

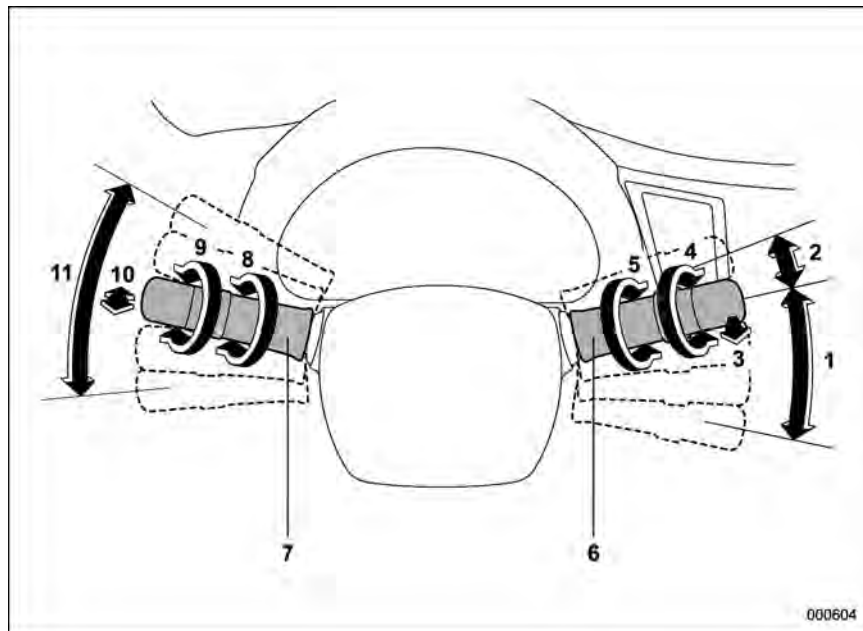

- 1) Windshield wiper (page 3-31)
- 2) Mist (page 3-32)
- 3) Windshield washer (page 3-33)
- 4) Rear window wiper and washer switch (page 3-34)
- 5) Wiper intermittent time control switch (page 3-33)
- 6) Wiper control lever (page 3-32)
- 7) Light control switch (page 3-27)
- 8) Front fog light switch (page 3-30)
- 9) Headlight ON/OFF/AUTO (page 3-27)
- 10) Headlight flasher High/Low beam change (page 3-28)
- 11) Turn signal lever (page 3-29)

■ Combination meter

▼ U.S.-spec. models

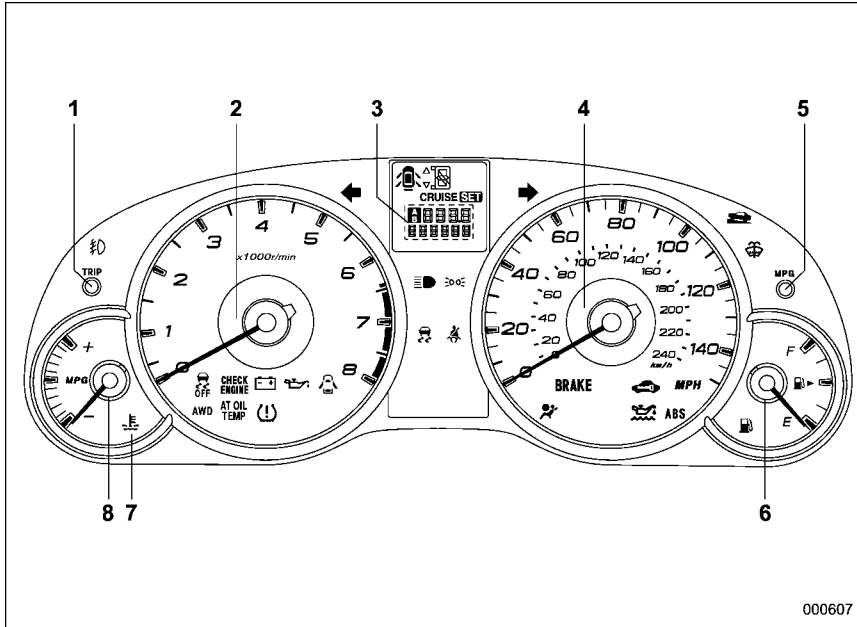

- 1) Trip meter A/B selection and trip meter reset knob (page 3-6)
- 2) Tachometer (page 3-7)
- 3) Trip meter and odometer (page 3-6)
- 4) Speedometer (page 3-6)
- 5) Multi function display switching knob (page 3-24)
- 6) Fuel gauge (page 3-7)
- 7) Coolant temperature warning/indicator light (page 3-13)
- 8) ECO gauge (page 3-8)

000607



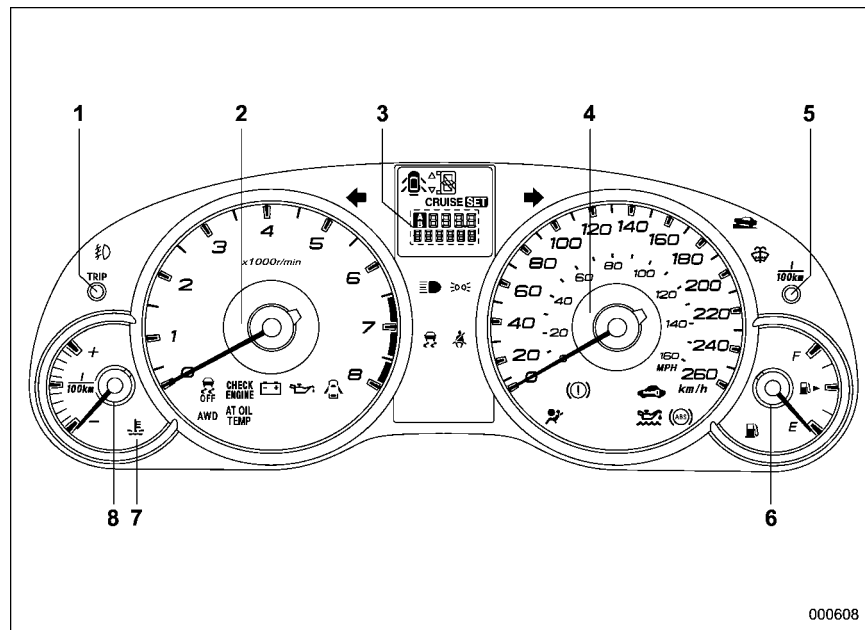





▼ Canada-spec. models



















- 1) Trip meter A/B selection and trip meter reset knob (page 3-6)
- 2) Tachometer (page 3-7)
- 3) Trip meter and odometer (page 3-6)
- 4) Speedometer (page 3-6)
- 5) Multi function display switching knob (page 3-24)
- 6) Fuel gauge (page 3-7)
- 7) Coolant temperature warning/indicator light (page 3-13)
- 8) ECO gauge (page 3-8)

000608

■ Warning and indicator lights

| Mark | Name | Page |
|---|--|------|
|  | Seatbelt warning light | 3-10 |
|  | Front passenger's seatbelt warning light | 3-10 |
|  | SRS airbag system warning light | 3-11 |
| CHECK ENGINE | CHECK ENGINE warning light/Malfunction indicator lamp | 3-12 |
|  | Coolant temperature low indicator light/Coolant temperature high warning light | 3-13 |
|  | Charge warning light | 3-14 |
|  | Oil pressure warning light | 3-14 |
|  | Engine oil level warning light | 3-14 |
| AT OIL TEMP | AT OIL TEMP warning light (AT and CVT models) | 3-15 |
| ABS /  | ABS warning light | 3-16 |

| Mark | Name | Page |
|---|---|------|
| BRAKE /  | Brake system warning light | 3-17 |
|  | Hill Holder indicator light | 3-19 |
|  | Door open warning light | 3-20 |
|  | Door open indicator light | 3-20 |
|  | Low fuel warning light | 3-19 |
| AWD | All-Wheel Drive warning light (AT and CVT models) | 3-20 |
|  | Vehicle Dynamics Control warning light/Vehicle Dynamics Control operation indicator light | 3-20 |
|  | Vehicle Dynamics Control OFF indicator light | 3-21 |
|  | Security indicator light | 3-22 |
|  | Turn signal indicator lights | 3-23 |
|  | High beam indicator light | 3-23 |

| Mark | Name | Page |
|---|--|---------------|
|  | Front fog light indicator light (if equipped) | 3-23 |
| CRUISE | Cruise control indicator light | 3-23 |
| SET | Cruise control set indicator light | 3-23 |
|  | Headlight indicator light | 3-23 |
|  | Low tire pressure warning light (U.S.-spec. models) | 3-15 |
| ON /  | Front passenger's frontal airbag ON indicator light | 1-46/ 3-12 |
| OFF /  | Front passenger's frontal airbag OFF indicator light | 1-46/ 3-12 |
|  | Shift-up indicator | 3-22 |
|  | Windshield washer fluid warning light | 3-20 |

Function settings

A SUBARU dealer can change the settings of the functions shown in the following table to meet your personal requirements. Contact the nearest SUBARU dealer for details.

| Item | Function | Possible settings | Default setting | Page |
|---|---|---|--------------------------|------|
| Alarm system | Alarm system | Operation/Non-operation | Operation | 2-16 |
| | Monitoring start delay time (after closure of doors) | 0 second/30 seconds | 30 seconds | 2-17 |
| | Impact sensor operation (only models with shock sensors (dealer option)) | Operation/Non-operation | Non-operation | 2-19 |
| | Passive arming | Operation/Non-operation | Non-operation | 2-18 |
| | Map light/Dome light/Cargo area light illumination | ON/OFF | OFF | 2-16 |
| Remote keyless entry system | Hazard warning flasher | Operation/Non-operation | Operation | 2-8 |
| | Audible signal | Operation/Non-operation | Operation | 2-11 |
| Key lock-in prevention | Key lock-in prevention | Operation/Non-operation | Operation | 2-7 |
| Defogger and deicer system for models with the automatic climate control system | Rear window defogger, outside mirror defogger and windshield wiper deicer | Operation for 15 minutes/ Continuous operation | Operation for 15 minutes | 3-34 |
| Map light/Dome light/Cargo area light | Operation of map light/Dome light/Cargo area light OFF delay timer | OFF/Short/Normal/Long | Long | 6-2 |
| Battery drainage prevention function | Battery drainage prevention function | Operation/Non-operation | Operation | 2-6 |
| Seatbelt warning | Sounds a chime while driving | Operation/Non-operation | Operation | 1-14 |
| Auto on/off headlights | Sensitivity of the operation of the auto on/off headlights | Low/Normal/High/Very high | Normal | 3-28 |

| | | | |
|---|-------------|---|-------------|
| Front seats | 1-2 | Precautions against vehicle modification | 1-24 |
| Manual seat | 1-3 | Child restraint systems | 1-25 |
| Power seat (if equipped)..... | 1-4 | Where to place a child restraint system..... | 1-26 |
| Head restraint adjustment..... | 1-5 | Choosing a child restraint system | 1-28 |
| Seat heater (if equipped) | 1-6 | Installing child restraint systems with A/ELR seatbelt | 1-28 |
| Rear seats | 1-7 | Installing a booster seat..... | 1-31 |
| Reclining the seatback (Outback)..... | 1-8 | Installation of child restraint systems by use of lower and tether anchorages (LATCH) | 1-33 |
| Folding down the rear seatback..... | 1-8 | Top tether anchorages | 1-35 |
| Head restraint adjustment..... | 1-10 | *SRS airbag (Supplemental Restraint System airbag) | 1-38 |
| Armrest | 1-12 | Models with SRS airbags and lap/shoulder restraints for driver, front passenger, and window-side rear passengers..... | 1-38 |
| Seatbelts | 1-12 | SUBARU advanced frontal airbag system | 1-43 |
| Seatbelt safety tips..... | 1-12 | SRS side airbag and SRS curtain airbag..... | 1-53 |
| Emergency Locking Retractor (ELR) | 1-13 | SRS airbag system monitors..... | 1-62 |
| Automatic/Emergency Locking Retractor (A/ELR)..... | 1-13 | SRS airbag system servicing | 1-63 |
| Seatbelt warning light and chime | 1-14 | Precautions against vehicle modification..... | 1-64 |
| Fastening the seatbelt | 1-15 | | |
| Seatbelt maintenance | 1-22 | | |
| Front seatbelt pretensioners | 1-22 | | |
| System monitors | 1-23 | | |
| System servicing..... | 1-24 | | |

Front seats

WARNING

- Never adjust the seat while driving to avoid the possibility of loss of vehicle control and of personal injury.
- Before adjusting the seat, make sure the hands and feet of rear seat passengers or cargo are clear of the adjusting mechanism.
- Seatbelts provide maximum restraint when the occupant sits well back and upright in the seat. To reduce the risk of sliding under the seatbelt in a collision, the front seatbacks should be always used in the upright position while the vehicle is running. If the front seatbacks are not used in the upright position in a collision, the risk of sliding under the lap belt and of the lap belt sliding up over the abdomen will increase, and both can result in serious internal injury or death.
- The SRS airbags deploy with considerable speed and force. Occupants who are out of proper

position when the SRS airbag deploys could suffer very serious injuries. Because the SRS airbag needs enough space for deployment, the driver should always sit upright and well back in the seat as far from the steering wheel as practical while still maintaining full vehicle control and the front passenger should move the seat as far back as possible and sit upright and well back in the seat.



WARNING

Put children in the rear seat properly restrained at all times. The SRS airbag deploys with considerable speed and force and can injure or even kill children, especially if they are not restrained or improperly restrained. Because children are lighter and weaker than adults, their risk of being injured from deployment is greater. Consequently, we strongly recommend that ALL children (including those in child seats and those that have outgrown child restraint devices) sit in the REAR seat properly restrained at all times in a child restraint device or in a seatbelt, whichever is appropriate for the child's age, height and weight.

Secure ALL types of child restraint devices (including forward facing child seats) in the REAR seats at all times.

NEVER INSTALL A REARWARD FACING CHILD SEAT IN THE FRONT SEAT. DOING SO RISKS SERIOUS INJURY OR DEATH TO THE CHILD BY PLACING THE CHILD'S HEAD TOO CLOSE TO THE SRS AIRBAG.

According to accident statistics, children are safer when properly restrained in the rear seating positions than in the front seating positions. For instructions and precautions concerning child restraint systems, refer to “Child restraint systems” 1-25.

■ Manual seat

▼ Forward and backward adjustment



Pull the lever upward and slide the seat to the desired position. Then release the lever and move the seat back and forth to make sure that it is securely locked into place.

▼ Reclining the seatback



▲ WARNING

To prevent the passenger from sliding under the seatbelt in the event of a collision, always put the seatback in the upright position while the vehicle is in motion. Also, do not place objects such as cushions between the passenger and the seatback. If you do so, the risk of sliding under the lap belt and of the lap belt sliding up over the abdomen will increase, and both can result in serious internal injury or death.



Pull the reclining lever up and adjust the seatback to the desired position. Then release the lever and make sure the seatback is securely locked into place.

The seatback placed in a reclined position can spring back upward with force when the lever is pulled. When operating the reclining lever to return the seatback, hold the seatback lightly so that it may be raised back gradually.

▼ Seat height adjustment (driver's seat)

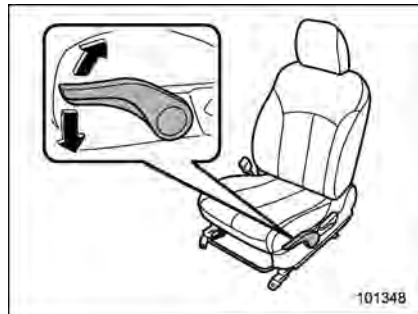

The height of the seat can be adjusted by moving the seat cushion adjustment lever up and down.

When the lever is pushed down, the seat is lowered.

When the lever is pulled up, the seat rises.

■ Power seat (if equipped)

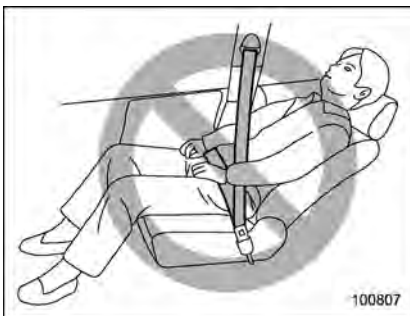

WARNING

To prevent the passenger from sliding under the seatbelt in the event of a collision, always put the seatback in the upright position while the vehicle is in motion. Also, do not place objects such as cushions between the passenger and the seatback. If you do so, the risk of sliding under the lap belt and of the lap belt sliding up over the abdomen will increase, and both can result in serious internal injury or death.

▼ Driver's seat



1) **Seat position forward/backward control switch**

To adjust the seat forward or backward, move the control switch forward or backward. During forward/backward adjustment of the seat, you cannot adjust

the seat cushion angle or seat cushion height.

- 2) **Seat cushion angle control switch**
To adjust the seat cushion angle, pull up or push down the front end of the control switch.
- 3) **Seatback angle (reclining) control switch**
To adjust the angle of the seatback, move the control switch.
- 4) **Seat height control switch**
To adjust the seat height, pull up or push down the rear end of the control switch.
- 5) **Lumbar support control switch**
To increase lower back support, push the front side of the switch. To decrease lower back support, push the rear side of the switch.

▼ Front passenger's seat (if equipped)



- 1) **Seat position forward/backward control switch**
To adjust the seat forward or backward, move the control switch forward or backward.
- 2) **Seatback angle (reclining) control switch**
To adjust the angle of the seatback, move the control switch.

■ Head restraint adjustment

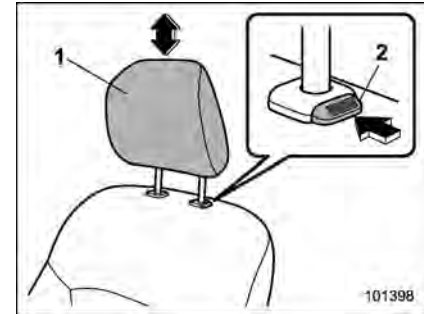

- 1) Head restraint
- 2) Release button

Both the driver's seat and the front passenger's seat are equipped with head restraints.

The head restraint should be adjusted so that the center of the head restraint is closest to the top of the occupant's ears.

To raise:

Pull the head restraint up.

To lower:

Push the head restraint down while pressing the release button on the top of the seatback.

To remove:

While pressing the release button, pull out the head restraint.

To install:

Install the head restraint into the holes that are located on the top of the seatback until the head restraint locks.

WARNING

- Never drive the vehicle with the head restraints removed because they are designed to reduce the risk of serious neck injury in the event that the vehicle is struck from the rear. Therefore, when you remove the head restraints, you must reinstall all head restraints to protect vehicle occupants.
- All occupants, including the driver, should not operate a vehicle or sit in a vehicle's seat until the head restraints are placed in their proper positions in order to minimize the risk of neck injury in the event of a collision.

Seat heater (if equipped)

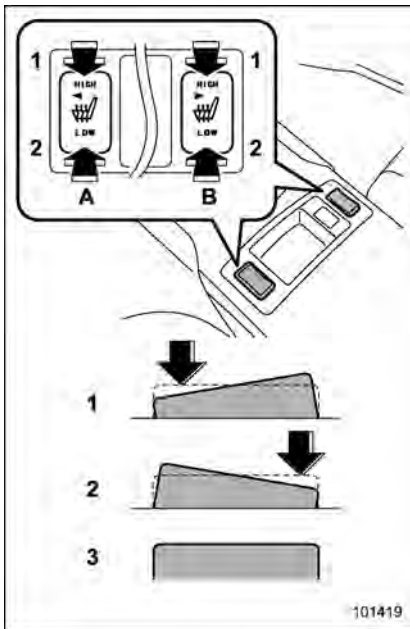

- 1) **HIGH** – Rapid heating
 - 2) **LOW** – Normal heating
 - 3) **OFF** – Off
- A) Left-hand side
B) Right-hand side

The seat heater operates when the ignition switch is either in the "Acc" or "ON" position.

To turn on the seat heater, press the "LOW" or "HIGH" position on the switch, as desired, depending on the temperature.

Selecting the "HIGH" position will cause the seat to heat up quicker.

To turn off the seat heater, slightly press the opposite side of the current position.

The indicator located on the switch illuminates when the seat heater is in operation. When the vehicle's interior is warmed enough or before you leave the vehicle, be sure to turn the switch off.

CAUTION

- There is a possibility that people with delicate skin may suffer slight burns even at low temperatures if they use the seat heater for a long period of time. When using the heater, always be sure to warn the persons concerned.

- Do not put anything on the seat which insulates against heat, such as a blanket, cushion, or similar items. This may cause the seat heater to overheat.

NOTE

Use of the seat heater for a long period of time while the engine is not running can cause battery discharge.

Rear seats



WARNING

Seatbelts provide maximum restraint when the occupant sits well back and upright in the seat. Do not put cushions or any other materials between occupants and seatbacks or seat cushions. If you do so, the risk of sliding under the lap belt and of the lap belt sliding up over the abdomen will increase, and both can result in serious internal injury or death.

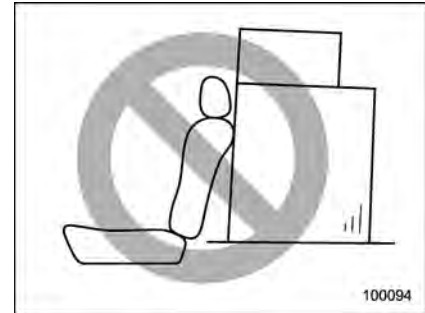

WARNING

Never stack luggage or other cargo higher than the top of the seatback because it could tumble forward and injure passengers in the event of a sudden stop or accident.

■ Reclining the seatback (Out-back)



WARNING

To prevent the passenger from sliding under the seatbelt in the event of a collision, always put the seatback in the upright position while the vehicle is in motion.

CAUTION

If the vehicle is equipped with a cargo area cover, observe the following precautions.

- Be careful not to pinch your hand between the headrest and the

cargo area cover when you recline the rear seat.

- Move the front cover of the cargo area cover backward so that the cover is not damaged by the reclined seatback. Refer to “Cargo area cover” 6-15.

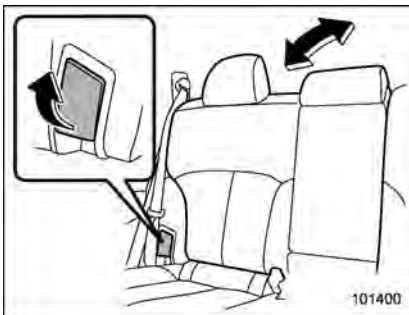

Pull the lever and adjust the seatback to the desired position.

Then release the lever and make sure the seatback is securely locked into place.

■ Folding down the rear seatback

WARNING

- After returning the rear seat to its original position, be certain to place all of the seatbelts and the tab attached to the seat cushion above the seat cushion. And make certain that the shoulder belts are fully visible.
- Never allow passengers to ride on the folded rear seatback or in the cargo area or trunk. Doing so may result in serious injury or death.
- Secure all objects and especially long items properly to prevent them from being thrown around inside the vehicle and causing serious injury during a sudden stop, a sudden steering maneuver or a rapid acceleration.

CAUTION

The rear seatback may fold down quickly due to the internal spring. Hold the seatback while pulling the release lever to slow it down.

▼ Legacy

CAUTION

Before folding down the rear seats, make sure that no one is sitting and nothing is placed on the rear seats. Otherwise, the seatback may fold down suddenly and an unexpected accident may occur.

To fold down the seatback, perform the following procedure.

1. Open the trunk lid. Refer to "Opening the trunk lid (Legacy)" 2-10 or "To open the trunk lid from inside" 2-24.

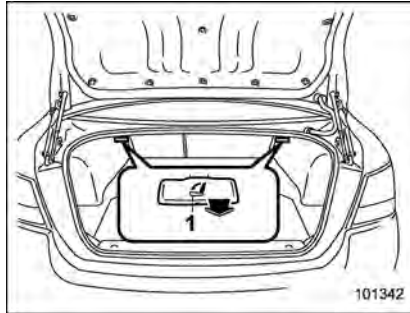

1) Release lever

2. Pull the release lever on the side that you want to fold down.
3. Fold the seatback down.

To return the seatback to its original position, raise the seatback until it locks into place and make sure that it is securely locked.

▼ Outback

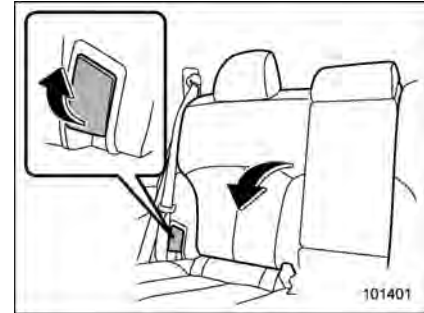

Unlock the seatback by pulling the release lever and then fold the seatback down.

To return the seatback to its original position, raise the seatback until it locks into place and make sure that it is securely locked.

■ Head restraint adjustment

Both the rear window side seats and the rear center seat are equipped with head restraints.

WARNING

- Never drive the vehicle with the head restraints removed because they are designed to reduce the risk of serious neck injury in the event that the vehicle is struck from the rear. Therefore, when you remove the head restraints, you must reinstall all head restraints to protect vehicle occupants.
- All occupants, including the driver, should not operate a vehicle or sit in a vehicle's seat until the head restraints are placed in their proper positions in order to minimize the risk of neck injury in the event of a collision.

▼ Rear window side seating position

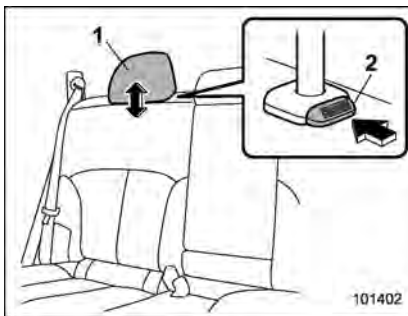

- 1) Head restraint
- 2) Release button

To raise:

Pull the head restraint up.

To lower:

Push the head restraint down while pressing the release button on the top of the seatback.

To remove:

While pressing the release button, pull out the head restraint.

To install:

Install the head restraint into the holes that are located on the top of the seatback until the head restraint locks.

The head restraint should be adjusted so

that the center of the head restraint is closest to the top of the occupant's ears. When the seats are not occupied, lower the head restraints to improve rearward visibility.

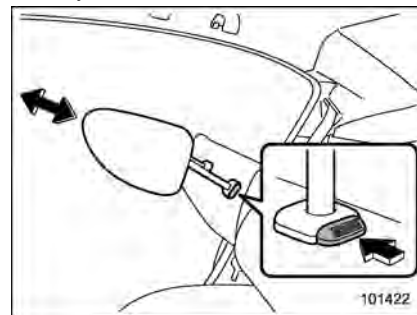

NOTE

For Legacy, it is not possible to remove or install the head restraint without folding down the rear seatback. Fold down the rear seatback and then remove or install the head restraint.

▼ Rear center seating position

CAUTION

The head restraint is not intended to be used at the lowest position. Before sitting on the seat, raise the head restraint to the extended position.

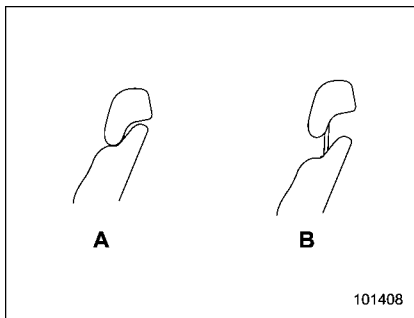

- A) When not used (retracted position)
 B) When used (extended position)

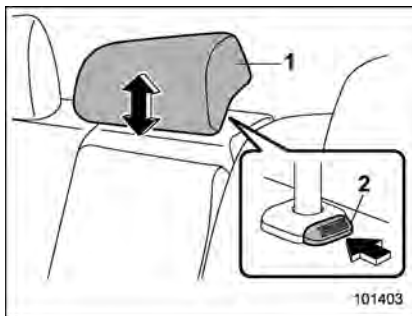

- 1) Head restraint
 2) Release button

To raise:

Pull the head restraint up.

To lower:

Push the head restraint down while pressing the release button on the top of the seatback.

To remove:

While pressing the release button, pull out the head restraint.

To install:

Install the head restraint into the holes that are located on the top of the seatback until the head restraint locks.

When the rear-center seating position is occupied, raise the head restraint to the

extended position. When the rear center seating position is not occupied, lower the head restraint to improve rearward visibility.

Armrest

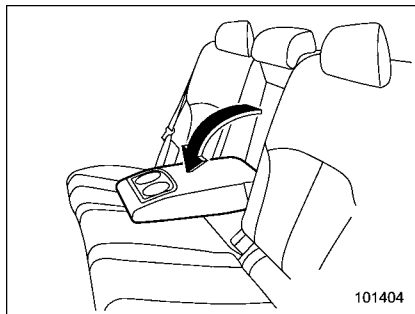

To lower the armrest, pull on the top edge of the armrest.

WARNING

To avoid the possibility of serious injury, passengers must never be allowed to sit on the center armrest while the vehicle is in motion.

Seatbelts

■ Seatbelt safety tips

WARNING

- All persons in the vehicle should fasten their seatbelts **BEFORE** the vehicle starts to move. Otherwise, the possibility of serious injury becomes greater in the event of a sudden stop or accident.
- All belts should fit snugly in order to provide full restraint. Loose fitting belts are not as effective in preventing or reducing injury.
- Each seatbelt is designed to support only one person. Never use a single belt for two or more persons – even children. Otherwise, in an accident, serious injury or death could result.
- Replace all seatbelt assemblies including retractors and attaching hardware worn by occupants of a vehicle that has been in a serious accident. The entire assembly should be replaced even if damage is not obvious.

- Put children in the rear seat properly restrained at all times. The SRS airbag deploys with considerable speed and force and can injure or even kill children, especially if they are not restrained or improperly restrained. Because children are lighter and weaker than adults, their risk of being injured from deployment is greater. Consequently, we strongly recommend that **ALL** children (including those in child seats and those that have outgrown child restraint devices) sit in the **REAR** seat properly restrained at all times in a child restraint device or in a seatbelt, whichever is appropriate for the child's height and weight.

Secure **ALL** types of child restraint devices (including forward facing child seats) in the **REAR** seats at all times.

NEVER INSTALL A REARWARD FACING CHILD SEAT IN THE FRONT SEAT. DOING SO RISKS SERIOUS INJURY OR DEATH TO THE CHILD'S HEAD TOO CLOSE TO THE SRS AIRBAG.

According to accident statistics, children are safer when properly restrained in the rear seating positions than in the front seating positions. For instructions and precautions concerning the child restraint system, refer to “Child restraint systems” 1-25.

Your vehicle is equipped with a crash sensing and diagnostic module, which will record the use of the seatbelt by the front passenger when any of the SRS frontal, side and curtain airbags deploys.

▼ Infants or small children

Use a child restraint system that is suitable for your vehicle. Refer to “Child restraint systems” 1-25.

▼ Children

If a child is too big for a child restraint system, the child should sit in the rear seat and be restrained using the seatbelts. According to accident statistics, children are safer when properly restrained in the rear seating positions than in the front seating positions. Never allow a child to stand up or kneel on the seat.

If the shoulder portion of the belt crosses the face or neck, move the child closer to the belt buckle to help provide a good

shoulder belt fit. Care must be taken to securely place the lap belt as low as possible on the hips and not on the child's waist. If the shoulder portion of the belt cannot be properly positioned, a child restraint system should be used. Never place the shoulder belt under the child's arm or behind the child's back.

▼ Expectant mothers

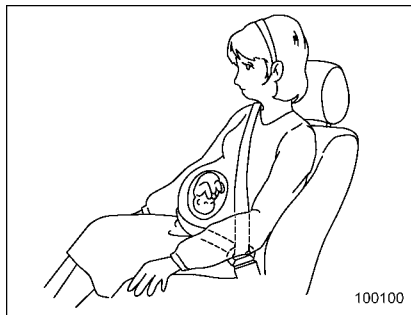

Expectant mothers also need to use the seatbelts. They should consult their doctor for specific recommendations. The lap belt should be worn securely and as low as possible over the hips, not over the waist.

■ Emergency Locking Retractor (ELR)

The driver's seatbelt has an Emergency Locking Retractor (ELR).

The emergency locking retractor allows normal body movement but the retractor locks automatically during a sudden stop, impact or if you pull the belt very quickly out of the retractor.

■ Automatic/Emergency Locking Retractor (A/ELR)

Each passenger's seatbelt has an Automatic/Emergency Locking Retractor (A/ELR). The Automatic/Emergency Locking Retractor normally functions as an Emergency Locking Retractor (ELR). The A/ELR has an additional locking mode “Automatic Locking Retractor (ALR) mode” intended to secure a child restraint system. When the seatbelt is once drawn out completely and is then retracted even slightly, the retractor locks the seatbelt in that position and the seatbelt cannot be extended. As the belt is rewinding, clicks will be heard which indicate the retractor functions as ALR. When the seatbelt is retracted fully, ALR mode is canceled.

When securing a child restraint system on the passengers' seats, the seatbelt must be changed over to the Automatic Locking

Retractor (ALR) mode.

When the child restraint system is removed, make sure that the seatbelt retracts fully and the retractor returned to the Emergency Locking Retractor (ELR) mode.

For instructions on how to convert the retractor to the ALR mode and restore it to the ELR mode, refer to "Installing child restraint systems with A/ELR seatbelt" 1-28.

■ Seatbelt warning light and chime



NOTE

If your seatbelt warning device does not operate as described in the following, it may be out of order. Have the device inspected and, if necessary, repaired by the nearest SUBARU dealer.

Your vehicle is equipped with a seatbelt warning device at the driver's and front passenger's seat, as required by current safety standards.

With the ignition switch turned to the "ON" position, this device reminds the driver and front passenger to fasten their seatbelts by the warning lights in the locations indicated in the following illustration and a chime.

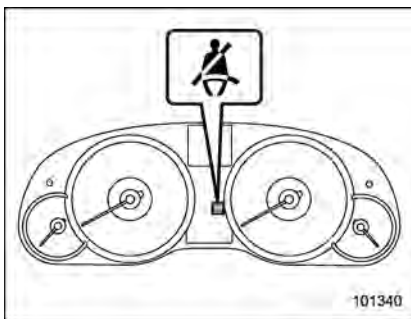

Driver's warning light

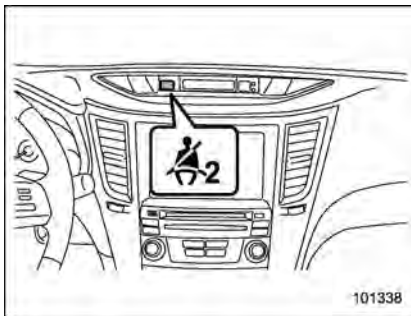

Front passenger's warning light

▼ Operation

If the driver and/or front passenger have/has not yet fastened the seatbelt(s) when

the ignition switch is turned to the "ON" position, the seatbelt warning light(s) will flash for 6 seconds, to warn that the seatbelt(s) is/are unfastened. If the driver's seatbelt is not fastened, a chime will also sound simultaneously.

NOTE

- If the driver's and/or front passenger's seatbelt(s) are/is still not fastened 6 seconds later, the seatbelt warning device operates as follows according to the vehicle speed.

- At speeds lower than approximately 9 mph (15 km/h)

The warning light(s) for unfastened seatbelt(s) will alternate between steady illumination and flashing at 15-second intervals. The chime will not sound.

- At speeds higher than approximately 9 mph (15 km/h)

The warning light(s) for unfastened seatbelt(s) will alternate between flashing and steady illumination at 15-second intervals and the chime will sound while the warning light(s) is/are flashing.

- It is possible to cancel the warning operation that follows the 6-second warning after turning ON the ignition switch. When the ignition switch is

turned ON next time, however, the complete sequence of the warning operation resumes. For further details about canceling the warning operation, please contact your SUBARU dealer.

If there is no passenger on the front passenger's seat, the seatbelt warning device for the front passenger's seat will be deactivated. The front passenger's occupant detection system monitors whether or not there is a passenger on the front passenger's seat.

Observe the following precautions. Failure to do so may prevent the device from functioning correctly or cause the device to fail.

- Do not install any accessory such as a table or TV onto the seatback.
- Do not store a heavy load in the seatback pocket.
- Do not allow the rear seat occupant to place his/her hands or legs on the front passenger's seatback, or allow him/her to pull the seatback.
- Do not use front seats with their backward-forward position and seatback not being locked into place securely. If any of them are not locked securely, adjust them again. For the adjusting procedure, refer to "Manual seat" 1-3 (models equipped with manual seats only).

If the seatbelt warning device for the front passenger's seat does not function correctly (e.g., it is activated even when the front passenger's seat is empty or it is deactivated even when the front passenger has not fastened his/her seatbelt), take the following actions.

- Ensure that no article is placed on the seat other than a child restraint system and the child occupant.
- Ensure that there is no article left in the seatback pocket.
- Ensure that the backward-forward position and seatback of front passenger's seat are locked into place securely by moving the seat back and forth. (Models equipped with manual seats only)

■ Fastening the seatbelt



WARNING

- Never use a belt that is twisted or reversed. In an accident, this can increase the risk or severity of injury.
- Keep the lap belt as low as possible on your hips. In a collision, this spreads the force of the lap belt over stronger hip bones instead of across the weaker abdomen.

- Seatbelts provide maximum restraint when the occupant sits well back and upright in the seat. To reduce the risk of sliding under the seatbelt in a collision, the front seatbacks should be always used in the upright position while the vehicle is running. If the front seatbacks are not used in the upright position in a collision, the risk of sliding under the lap belt and of the lap belt sliding up over the abdomen will increase, and both can result in serious internal injury or death.
- Do not put cushions or any other materials between occupants and seatbacks or seat cushions. If you do so, the risk of sliding under the lap belt and of the lap belt sliding up over the abdomen will increase, and both can result in serious internal injury or death.

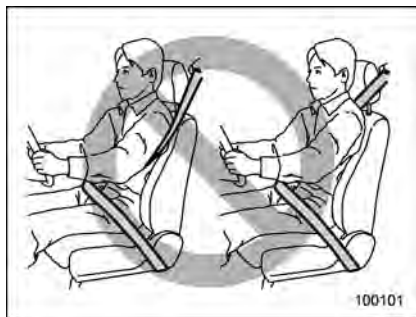

WARNING

Never place the shoulder belt under the arm or behind the back. If an accident occurs, this can increase the risk or severity of injury.



CAUTION

Metallic parts of the seatbelt can become very hot in a vehicle that has been closed up in sunny weather; they could burn an occupant. Do not touch such hot parts until they cool.

▼ **Front seatbelts**

1. Adjust the seat position:

Driver's seat: Adjust the seatback to the upright position. Move the seat as far from the steering wheel as practical while still maintaining full vehicle control.

Front passenger's seat: Adjust the seatback to the upright position. Move the seat as far back as possible.

2. Sit well back in the seat.

3. Pick up the tongue plate and pull the belt out slowly. Do not let it get twisted. If the belt stops before reaching the buckle, return the belt slightly and pull it out more slowly. If the belt still cannot be unlocked, let the belt retract slightly after giving it a strong pull, then pull it out slowly again.

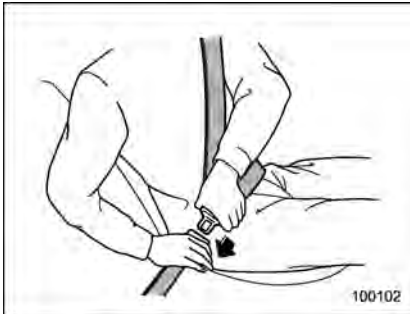

4. Insert the tongue plate into the buckle

until you hear a click.

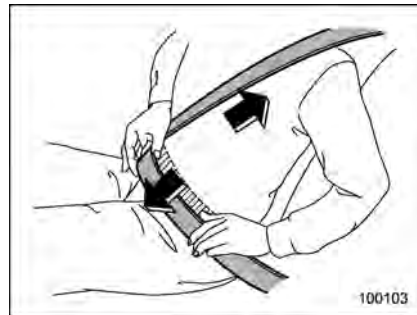

5. To make the lap part tight, pull up on the shoulder belt.

6. Place the lap belt as low as possible on your hips, not on your waist.

▽ Adjusting the front seat shoulder belt anchor height

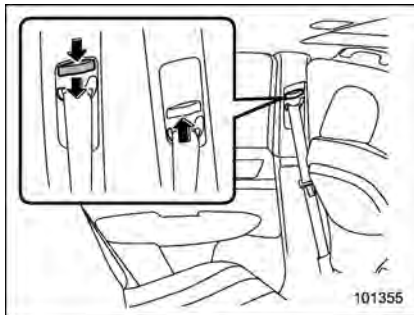

The shoulder belt anchor height should be adjusted to the position best suited for the driver/front passenger. Always adjust the anchor height so that the shoulder belt passes over the middle of the shoulder without touching the neck.

To raise:

Slide the anchor up.

To lower:

Push the release button and slide the anchor down.

Pull down the anchor to make sure that it is locked in place.

WARNING

When wearing the seatbelts, make sure the shoulder portion of the webbing does not pass over your neck. If it does, adjust the seatbelt anchor to a lower position. Placing the shoulder belt over the neck may result in neck injury during sudden braking or in a collision.

▽ Unfastening the seatbelt

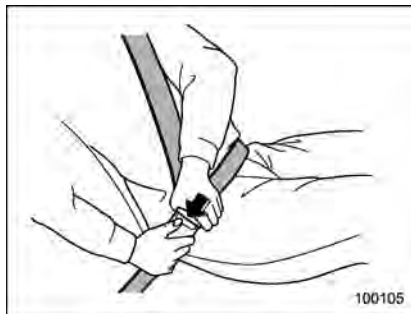

Push the button on the buckle.

Before closing the door, make sure that the belts are retracted properly to avoid catching the belt webbing in the door.

▽ Rear seatbelts (except rear center seatbelt on Outback)

1. Sit well back in the seat.
2. Pick up the tongue plate and pull the belt out slowly. Do not let it get twisted. If the belt stops before reaching the buckle, return the belt slightly and pull it out more slowly. If the belt still cannot be unlocked, let the belt retract slightly after giving a strong pull on it, then pull it out slowly again.

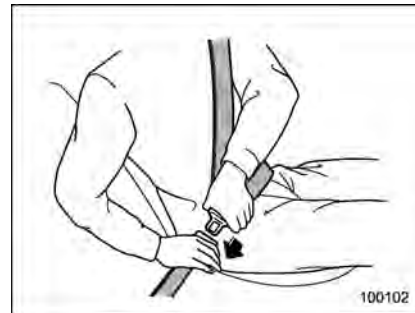

3. Insert the tongue plate into the buckle until you hear a click.

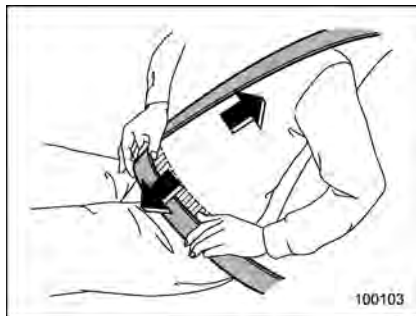

4. To make the lap part tight, pull up on the shoulder belt.
5. Place the lap belt as low as possible on your hips, not on your waist.

▼ Unfastening the seatbelt

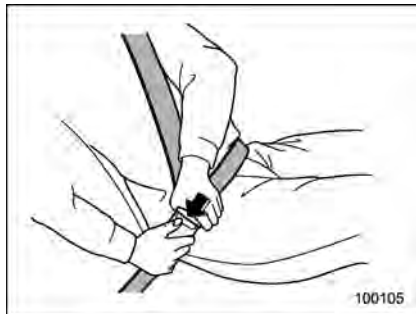

Push the button on the buckle.

Before closing the door, make sure that the belts are retracted properly to avoid catching the belt webbing in the door.

▼ Rear center seatbelt on Outback

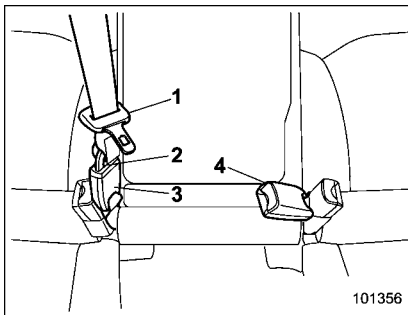

- 1) Center seatbelt tongue plate
- 2) Connector (tongue)
- 3) Connector (buckle)
- 4) Center seatbelt buckle

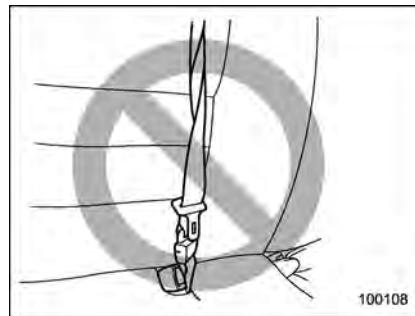

WARNING

Fastening the seatbelt with the webbing twisted can increase the risk or severity of injury in an accident. When fastening the belt after it is pulled out from the retractor, especially when inserting the connector's tongue plate into the mating buckle (on right-hand side), always check that the webbing is not twisted.



WARNING

Be sure to fasten both tongue plates to the respective buckles. If the seatbelt is used only as a shoulder belt (with the connector's tongue plate not fastened to the connector's buckle on the right-hand side), it cannot properly restrain the wearer in position in an accident, possibly resulting in serious injury or death.

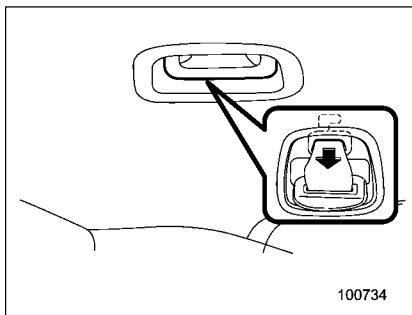

Rear center seatbelt is stowed in the recess of the ceiling.

1. Retrieve the connector (tongue) plate from the slot in the recess by pulling the connector (tongue) plate.

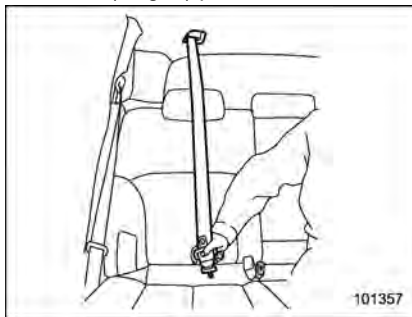

2. Pull out the seatbelt slowly from the retractor.

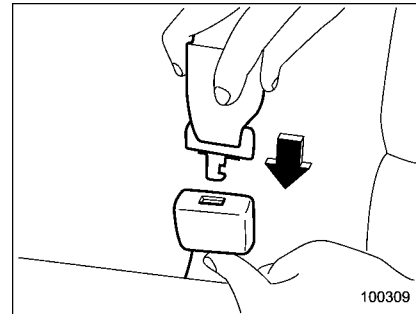

3. After confirming that the webbing is not twisted, insert the connector (tongue) attached at the webbing end into the buckle on the right-hand side until a click is heard. If the belt stops before reaching the buckle, return the belt slightly and pull it out more slowly. If the belt still cannot be unlocked, let the belt retract slightly after giving it a strong pull, then pull it out slowly again.

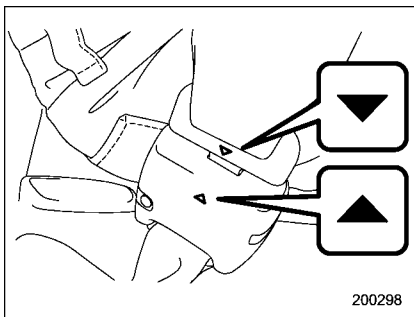

4. After fastening the seatbelt, make sure that the “▼” mark on the connector (tongue) and the “▲” mark on the buckle face outwards.

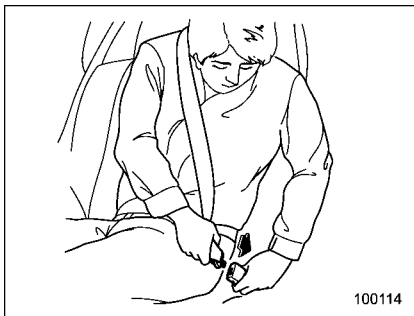

5. Insert the center seatbelt tongue plate into the center seatbelt buckle marked

“CENTER” on the left-hand side until it clicks.

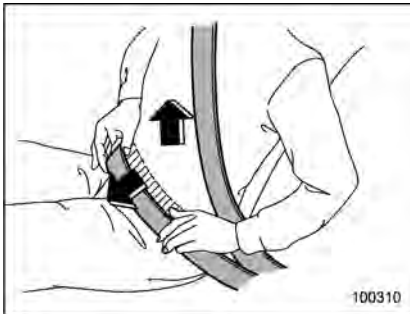

6. To make the lap part tight, pull up on the shoulder belt. And place the lap belt as low as possible on your hips, not on your waist.

▽ Unfastening the seatbelt



Push the release button of the center seatbelt buckle (on the left-hand side) to unfasten the seatbelt.

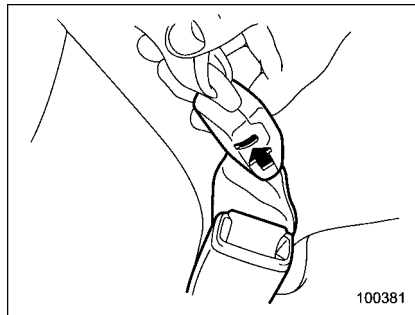

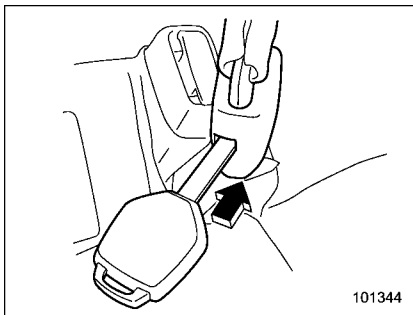

1. Insert a key or other hard pointed object into the slot in the connector (buckle) on the right-hand side and push it in, and the connector (tongue) plate will disconnect from the buckle.

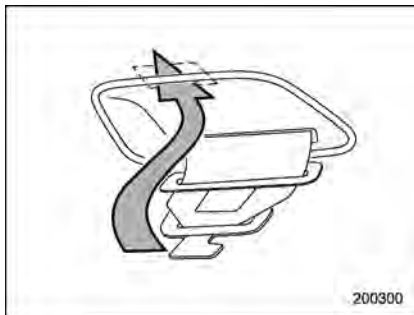

2. Allow the retractor to roll up the belt. You should hold the webbing end and guide it back into the retractor while it is rolling up. Neatly store the tongue plate in the recess and then insert the connector (tongue) plate into the slot.



CAUTION

- Do not allow the retractor to roll up the seatbelt too quickly. Otherwise, the metal tongue plates may hit against the trim, resulting in damaged trim.
- Have the seatbelt fully rolled up so that the tongue plates are neatly stored. A hanging tongue plate can swing and hit against the trim during driving, causing damage to the trim.

■ Seatbelt maintenance

To clean the seatbelts, use a mild soap and lukewarm water. Never bleach or dye the belts because this could seriously affect their strength.

Inspect the seatbelts and attachments including the webbing and all hardware periodically for cracks, cuts, gashes, tears, damage, loose bolts or worn areas. Replace the seatbelts even if only minor damage is found.

CAUTION

- **Keep the belts free of polishes, oils, chemicals and particularly battery acid.**
- **Never attempt to make modifications or changes that will prevent the seatbelt from operating properly.**

Front seatbelt pretensioners

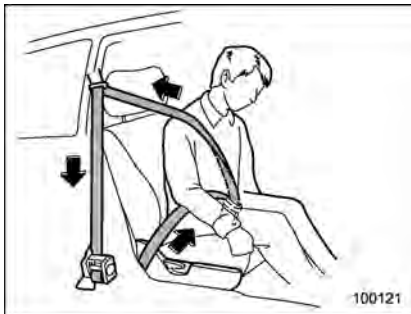

The driver's and front passenger's seatbelts have a seatbelt pretensioner. The seatbelt pretensioners are designed to be activated in the event of an accident involving a moderate to severe frontal collision.

The pretensioner sensor also serves as a SRS frontal airbag sensor. If the sensor detects a certain predetermined amount of force during a frontal collision, the front seatbelt is quickly drawn back in by the retractor to take up the slack so that the belt more effectively restrains the front seat occupant.

When a seatbelt pretensioner is activated, an operating noise will be heard and a

small amount of smoke will be released. These occurrences are normal and not harmful. This smoke does not indicate a fire in the vehicle.

Once the seatbelt pretensioner has been activated, the seatbelt retractor remains locked. Consequently, the seatbelt can not be pulled out and retracted and therefore must be replaced.

NOTE

- **Seatbelt pretensioners are not designed to activate in minor frontal impacts, in side or rear impacts or in roll-over accidents.**
- **The driver's seat and passenger's seat pretensioners and frontal airbag operate simultaneously.**
- **Pretensioners are designed to function on a one-time-only basis. In the event that a pretensioner is activated, both the driver's and front passenger's seatbelt retractor assemblies must be replaced and only by an authorized SUBARU dealer. When replacing seatbelt retractor assemblies, use only genuine SUBARU parts.**
- **If either front seatbelt does not retract or cannot be pulled out due to a malfunction or activation of the pretensioner, contact your SUBARU dealer as soon as possible.**

- If the front seatbelt retractor assembly or surrounding area has been damaged, contact your SUBARU dealer as soon as possible.
- When you sell your vehicle, we urge you to explain to the buyer that it has seatbelt pretensioners by alerting him to the contents of this section.

WARNING

- To obtain maximum protection, occupants should sit in an upright position with their seatbelts properly fastened. Refer to "Seatbelts" 1-12.
- Do not modify, remove or strike the front seatbelt retractor assemblies or surrounding area. This could result in accidental activation of the seatbelt pretensioners or could make the system inoperative, possibly resulting in serious injury. Seatbelt pretensioners have no user-serviceable parts. For required servicing of front seatbelt retractors equipped with seatbelt pretensioners, see your nearest SUBARU dealer.
- When discarding front seatbelt retractor assemblies or scrap-

ping the entire vehicle due to collision damage or for other reasons, consult your SUBARU dealer.

■ System monitors

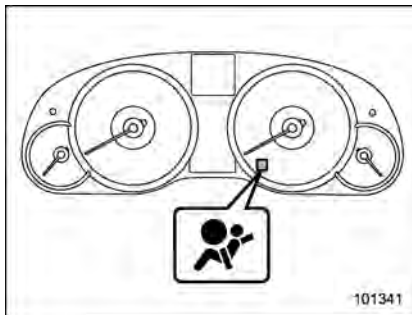

SRS airbag system warning light

A diagnostic system continually monitors the readiness of the seatbelt pretensioner while the vehicle is being driven. The seatbelt pretensioners share the control module with the airbag system. Therefore, if any malfunction occurs in a seatbelt pretensioner, the SRS airbag system warning light will illuminate. The SRS airbag system warning light will show normal system operation by lighting for approximately 6 seconds when the igni-

tion switch is turned to the "ON" position.

The following components are monitored by the indicator.

- Front sub sensor (right-hand side)
- Front sub sensor (left-hand side)
- Airbag control module (including impact sensors (all models) and rollover sensors (Outback))
- Frontal airbag module (driver's side)
- Frontal airbag module (front passenger's side)
- Side airbag sensor (center pillar right-hand side)
- Side airbag sensor (center pillar left-hand side)
- Side airbag module (driver's side)
- Side airbag module (front passenger's side)
- Curtain airbag sensor (rear wheel house right-hand side)
- Curtain airbag sensor (rear wheel house left-hand side)
- Curtain airbag module (right-hand side)
- Curtain airbag module (left-hand side)
- Seatbelt pretensioner (driver's side)
- Seatbelt pretensioner (front passenger's side)
- Seatbelt buckle switch (front passenger's side)
- Front passenger's occupant detection

– CONTINUED –

system weight sensor

- Front passenger's occupant detection control module
- Front passenger's frontal airbag ON and OFF indicator
- All related wiring



WARNING

If the warning light exhibits any of the following conditions, there may be a malfunction in the seatbelt pretensioners and/or SRS airbag system. Immediately take your vehicle to your nearest SUBARU dealer to have the system checked. Unless checked and properly repaired, the seatbelt pretensioners and/or SRS airbags will operate improperly (e.g. SRS airbags may inflate in a very minor collision or not inflate in a severe collision), which may increase the risk of injury.

- Flashing or flickering of the warning light
- No illumination of the warning light when the ignition switch is first turned to the "ON" position
- Continuous illumination of the warning light
- Illumination of the warning light

while driving

■ **System servicing**



WARNING

- When discarding a seatbelt retractor assembly or scrapping the entire vehicle damaged by a collision, consult your SUBARU dealer.
- Tampering with or disconnecting the system's wiring could result in accidental activation of the seatbelt pretensioner and/or airbag or could make the system inoperative, which may result in serious injury. Do not use electrical test equipment on any circuit related to the seatbelt pretensioner and airbag systems. For required servicing of the seatbelt pretensioner, consult your nearest SUBARU dealer.



CAUTION

The front sub sensors are located in both front fenders and the airbag control module including the impact

sensors is located under the center console. If you need service or repair in those areas or near the front seatbelt retractors, have an authorized SUBARU dealer perform the work.

NOTE

If the front part of the vehicle is damaged in an accident to the extent that the seatbelt pretensioner does not operate, contact your SUBARU dealer as soon as possible.

■ **Precautions against vehicle modification**

Always consult your SUBARU dealer if you want to install any accessory parts to your vehicle.



CAUTION

Do not perform any of the following modifications. Such modifications can interfere with proper operation of the seatbelt pretensioners.

- Attachment of any equipment (bush bar, winches, snow plow, skid plate, etc.) other than genuine SUBARU accessory parts to the front end.

- Modification of the suspension system or front end structure.
- Installation of a tire of different size and construction from the tires specified on the vehicle placard attached to the door pillar or specified for individual vehicle models in this Owner's Manual.

Child restraint systems



Infants and small children should always be placed in an infant or child restraint system in the rear seat while riding in the vehicle.

You should use an infant or child restraint system that meets Federal Motor Vehicle Safety Standards or Canada Motor Vehicle Safety Standards, is compatible with your vehicle and is appropriate for the child's age and size.

All child restraint systems are designed to be secured in vehicle seats by lap belts or the lap belt portion of a lap/shoulder belt (except those covered under the section in this manual, entitled "Installation of child restraint systems by use of lower and

tether anchorages (LATCH)" § 1-33).

Children could be endangered in an accident if their child restraints are not properly secured in the vehicle. When installing the child restraint system, carefully follow the manufacturer's instructions.

According to accident statistics, children are safer when properly restrained in the rear seating positions than in the front seating positions.

All U.S. states and Canadian provinces require that infants and small children be restrained in an approved child restraint system at all times while the vehicle is moving.



WARNING

Never let a passenger hold a child on his or her lap while the vehicle is moving. The passenger cannot protect the child from injury in a collision, because the child will be caught between the passenger and objects inside the vehicle. Additionally, holding a child in your lap or arms in the front seat exposes that child to another serious danger. Since the SRS airbag deploys with considerable speed and force, the child could be injured or even killed.

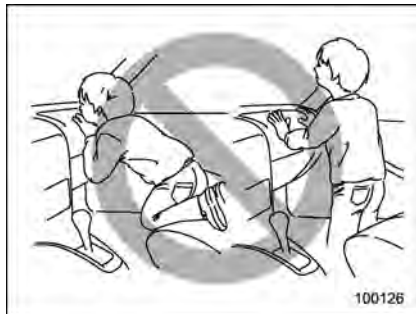

WARNING

Children should be properly restrained at all times. Never allow a child to stand up, or to kneel on any seat. Unrestrained children will be thrown forward during sudden stop or in an accident and can be injured seriously.

Additionally, children standing up or kneeling on or in front of the front seat are exposed another serious danger. Since the SRS airbag deploys with considerable speed and force, the child could be injured or even killed.

Where to place a child restraint system

The following descriptions are SUBARU's recommendations on where to place a child restraint system in your vehicle.

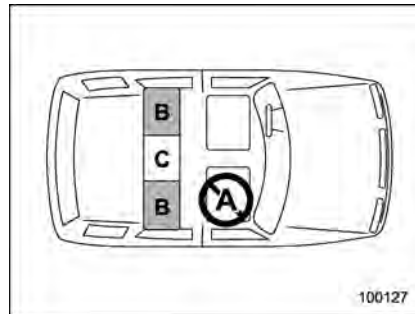

A: Front passenger's seat

You should not install a child restraint system (including a booster seat) due to the hazard to children posed by the passenger's airbag.

B: Rear seat, window-side seating positions

Recommended positions for all types of child restraint systems.

In these positions, Automatic/Emergency Locking Retractor (A/ELR) seatbelts and lower anchorages (bars) are provided for

installing a child restraint system.

Some types of child restraints might not be able to be secured firmly due to projection of the seat cushion.

In this seating position, you should use only a child restraint system that has a bottom base that fits snugly against the contours of the seat cushion and can be securely retained using the seatbelt.

C: Rear seat, center seating position

Installing a child restraint system is not recommended, although the A/ELR seatbelt and an upper anchorage (tether anchorage) are provided in this position. Some types of child restraints might not be able to be secured firmly due to projection of the seat cushion.

In this seating position, you should use only a child restraint system that has a bottom base that fits snugly against the contours of the seat cushion and can be securely retained using the seatbelt.

WARNING

Put children in the rear seat properly restrained at all times. The SRS airbag deploys with considerable speed and force and can injure or even kill children, especially if they are not restrained or improperly restrained. Because children are lighter and weaker than adults, their risk of being injured from deployment is greater.

For that reason, be sure to secure ALL types of child restraint devices (including forward facing child seats) in the REAR seats at all times. You should choose a restraint device which is appropriate for the child's age, height and weight. According to accident statistics, children are safer when properly restrained in the rear seating positions than in the front seating positions.



WARNING

SINCE YOUR VEHICLE IS EQUIPPED WITH A PASSENGER'S SRS AIRBAG, DO NOT INSTALL A REARWARD FACING CHILD SAFETY SEAT IN THE FRONT PASSENGER'S SEAT. DOING SO RISKS SERIOUS INJURY OR DEATH TO THE CHILD BY PLACING THE CHILD'S HEAD TOO CLOSE TO THE SRS AIRBAG.

■ **Choosing a child restraint system**

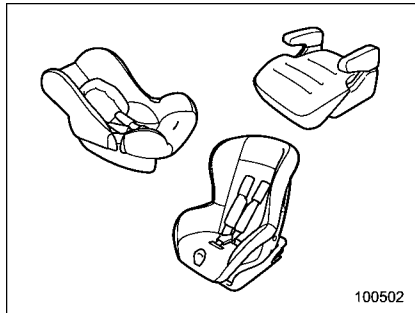

Choose a child restraint system that is appropriate for the child's age and size (weight and height) in order to provide the child with proper protection. The child restraint system should meet all applicable requirements of Federal Motor Vehicle Safety Standards for United States or Canada Motor Vehicle Safety Standards for Canada. It can be identified by looking for the label on the child restraint system or the manufacturer's statement of compliance in the document attached to the system. Also it is important for you to make sure that the child restraint system is compatible with the vehicle in which it will be used.

■ **Installing child restraint systems with A/ELR seatbelt**

▲ WARNING

- Child restraint systems and seatbelts can become hot in a vehicle that has been closed up in sunny weather; they could burn a small child. Check the child restraint system before you place a child in it.
- Do not leave an unsecured child restraint system in your vehicle. Unsecured child restraint systems can be thrown around inside of the vehicle in a sudden stop, turn or accident; they can strike and injure vehicle occupants as well as result in serious injuries or death to the child.

▲ CAUTION

When you install a child restraint system, follow the manufacturer's instructions supplied with it. After installing the child restraint system, check to ensure that it is held securely in position. If it is not held tight and secure, the danger of your child suffering personal injury in the event of an accident may be increased.

▼ **Installing a rearward facing child restraint**

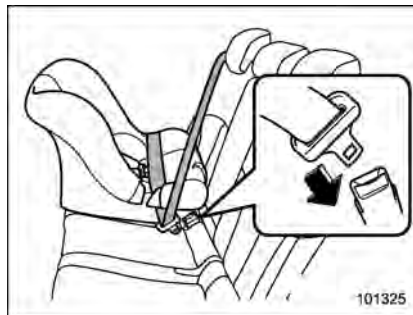

1. Place the child restraint system in the rear seating position.
2. Run the lap and shoulder belt through

or around the child restraint system following the instructions provided by its manufacturer.

3. Insert the tongue plate into the buckle until you hear a click.

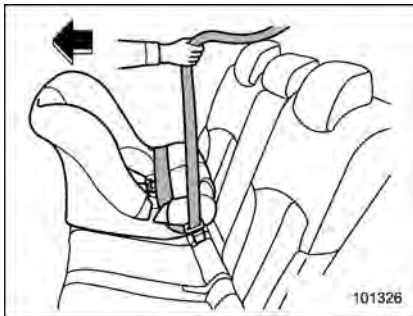

4. Take up the slack in the lap belt.
5. Pull out the seatbelt fully from the retractor to change the retractor over from the Emergency Locking Retractor (ELR) to the Automatic Locking Retractor (ALR) function. Then, allow the belt to rewind into the retractor. As the belt is rewinding, clicks will be heard which indicate the retractor functions as ALR.

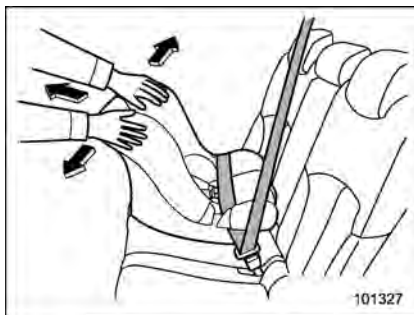

6. Push and pull the child restraint system forward and side to side to check if it is firmly secured in the center of the seat.

Sometimes a child restraint can be more firmly secured by pushing it down into the seat cushion and then tightening the seatbelt.

7. Pull at the shoulder portion of the belt to confirm that it cannot be pulled out (ALR properly functioning).

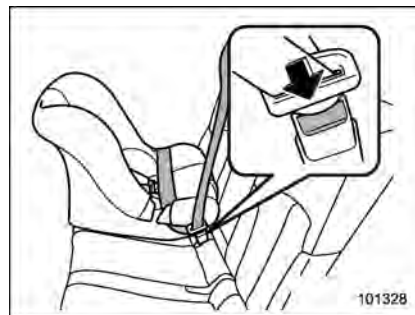

8. To remove the child restraint system, press the release button on the seatbelt buckle and allow the belt to retract completely. The belt will return to the ELR mode.

WARNING

NEVER INSTALL A REARWARD FACING CHILD SEAT IN THE FRONT PASSENGER'S SEAT. DOING SO RISKS SERIOUS INJURY OR DEATH TO THE CHILD BY PLACING THE CHILD'S HEAD TOO CLOSE TO THE SRS AIRBAG.

NOTE

When the child restraint system is no longer in use, remove it and restore the ELR function of the retractor. That function is restored by retracting the seatbelt fully.

▼ Installing forward facing child restraint

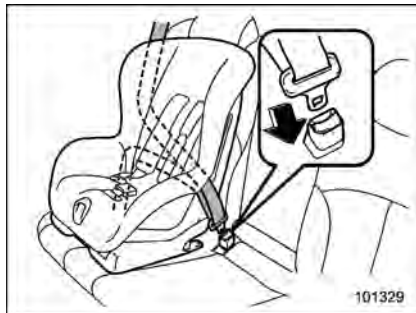

1. Place the child restraint system in the rear seating position.
2. Run the lap and shoulder belt through or around the child restraint system following the instructions provided by its manufacturer.
3. Insert the tongue plate into the buckle until you hear a click.

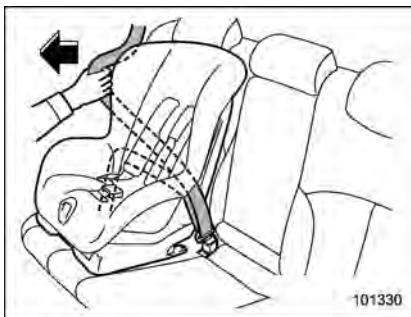

4. Take up the slack in the lap belt.
5. Pull out the seatbelt fully from the retractor to change the retractor over from the Emergency Locking Retractor (ELR) to the Automatic Locking Retractor (ALR) function. Then, allow the belt to rewind into the retractor. As the belt is rewinding, clicks will be heard which indicate the retractor functions as ALR.



6. Before seating a child in the child restraint system, try to move it back and forth and left and right to verify that it is firmly secured in the center of the seat. Sometimes a child restraint can be more firmly secured by pushing it down into the seat cushion and then tightening the seatbelt.
7. Pull at the shoulder portion of the belt to confirm that it cannot be pulled out (ALR properly functioning).

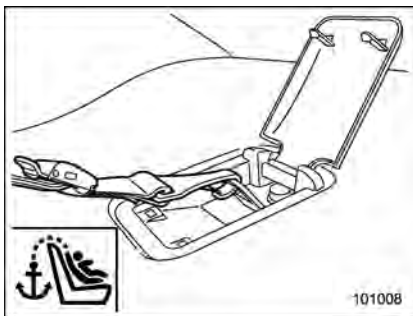

Legacy

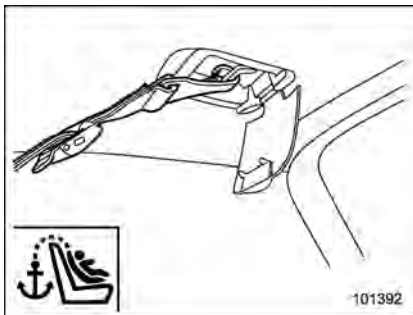

Outback

8. If the child restraint system requires a top tether, latch the hook onto the top tether anchor and tighten the top tether. For additional instructions, refer to “Top

tether anchorages” 1-35.

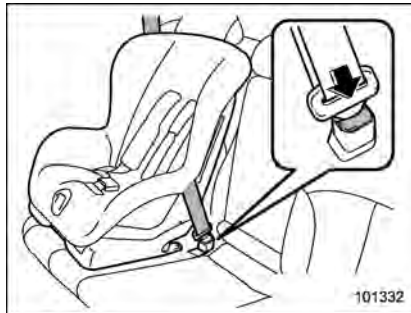

9. To remove the child restraint system, press the release button on the seatbelt buckle and allow the belt to retract completely. The belt will return to the ELR mode.

NOTE

When the child restraint system is no longer in use, remove it and restore the ELR function of the retractor. That function is restored by allowing the seatbelt to retract fully.

■ Installing a booster seat

▲ WARNING

- Child restraint systems and seatbelts can become hot in a vehicle that has been closed up in sunny weather; they could burn a small child. Check the child restraint system before you place a child in it.
- Do not leave an unsecured child restraint system in your vehicle. Unsecured child restraint systems can be thrown around inside of the vehicle in a sudden stop, turn or accident; they can strike and injure vehicle occupants as well as result in serious injuries or death to the child.

CAUTION

When you install a child restraint system, follow the manufacturer's instructions supplied with it. After installing the child restraint system, check to ensure that it is held securely in position. If it is not held tight and secure, the danger of your child suffering personal injury in the event of an accident may be increased.



1. Place the booster seat in the rear seating position and sit the child on it. The child should sit well back on the booster seat.
2. Run the lap and shoulder belt through or around the booster seat and the child

following the instructions provided by its manufacturer.

3. Insert the tongue plate into the buckle until you hear a click. Take care not to twist the seatbelt.

Make sure the shoulder belt is positioned across the center of child's shoulder and that the lap belt is positioned as low as possible on the child's hips.

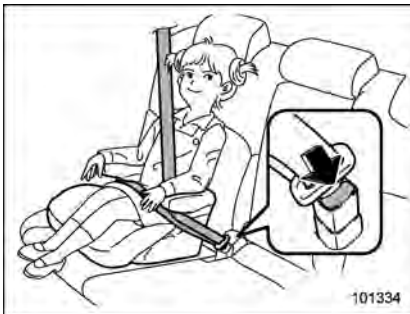

4. To remove the booster seat, press the release button on the seatbelt buckle and allow the belt to retract.

WARNING

- Never use a belt that is twisted or reversed. In an accident, this can increase the risk or severity of injury to the child.

- Never place the shoulder belt under the child's arm or behind the child's back. If an accident occurs, this can increase the risk or severity of injury to the child.
- The seatbelt should fit snugly in order to provide full restraint. Loose fitting belts are not as effective in preventing or reducing injury.
- Place the lap belt as low as possible on the child's hips. A high-positioned lap belt will increase the risk of sliding under the lap belt and of the lap belt sliding up over the abdomen, and both can result in serious internal injury or death.
- Make sure the shoulder belt is positioned across the center of child's shoulder. Placing the shoulder belt over the neck may result in neck injury during sudden braking or in a collision.

■ Installation of child restraint systems by use of lower and tether anchorages (LATCH)

⚠ WARNING

- Child restraint systems and seatbelts can become hot in a vehicle that has been closed up in sunny weather; they could burn a small child. Check the child restraint system before you place a child in it.
- Do not leave an unsecured child restraint system in your vehicle. Unsecured child restraint systems can be thrown around inside of the vehicle in a sudden stop, turn or accident; they can strike and injure vehicle occupants as well as result in serious injuries or death to the child.

⚠ CAUTION

When you install a child restraint system, follow the manufacturer's instructions supplied with it. After installing the child restraint system, check to ensure that it is held securely in position. If it is not held

tight and secure, the danger of your child suffering personal injury in the event of an accident may be increased.

Some types of child restraint systems can be installed on the rear seat of your vehicle without use of the seatbelts. Such child restraint systems are secured to the dedicated anchorages provided on the vehicle body.

The lower and tether anchorages are sometimes referred to as the LATCH system (Lower Anchors and Tethers for Children).



101210

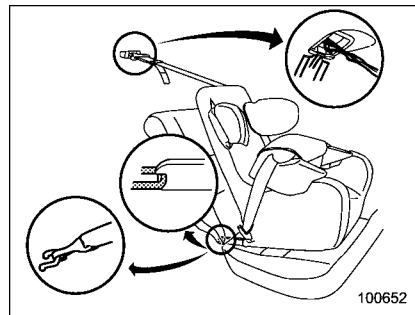

100652

Your vehicle is equipped with four lower anchorages (bars) and three upper anchorages (tether anchorages) for accommodating such child restraint systems.

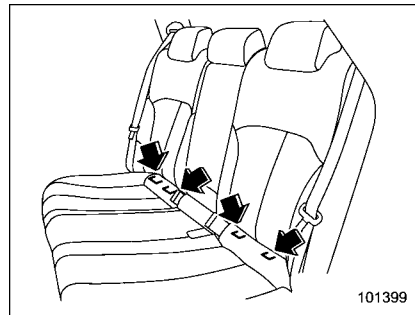

101399

The lower anchorages (bars) are used for installing a child restraint system only on

the rear seat window-side seating positions. For each window-side seating position, two lower anchorages are provided. Each lower anchorage is located behind the cover of seatback bottom.

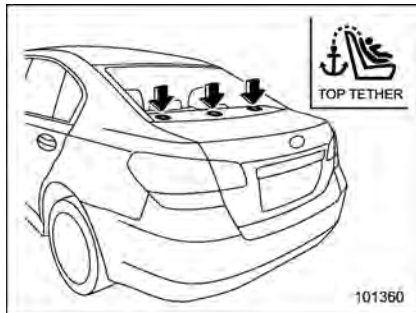

Legacy

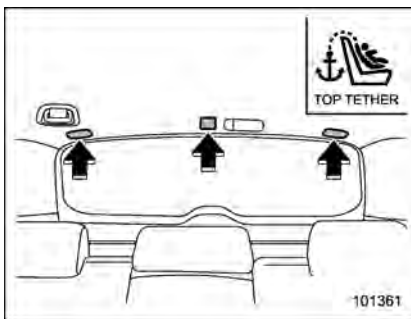

Outback

The tether anchorages (upper anchorages) are provided for all the seating positions (center and both window-side ones) of the rear seat.



You will find marks “” at the bottom of the

rear seat seatbacks. These marks indicate the positions of the lower anchorages (bars).

Each lower anchorage is located behind the cover of seatback bottom.

CAUTION

When you install a child restraint system, follow the manufacturer's instructions supplied with it. After installing the child restraint system, check to ensure that it is held securely in position. If it is not held tight and secure, the danger of your child suffering personal injury in the event of an accident may be increased.

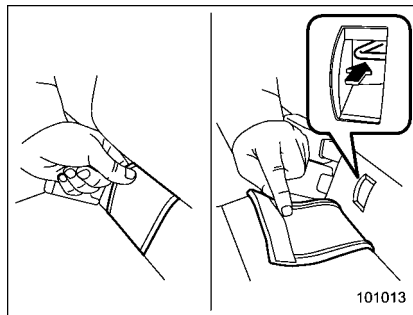

Peel off the anchorage cover from the selected side of the rear seatback to expose the anchorages (bars) to be used for installation of the child restraint system.

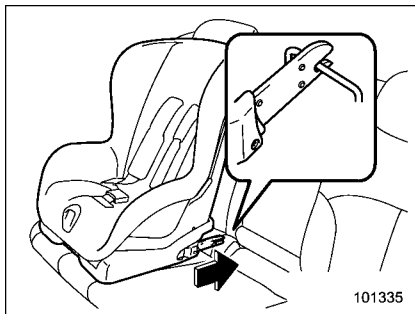

1. While following the instructions supplied by the child restraint system manufacturer, connect the lower hooks onto the lower anchorages located at “C” marks on the bottom of the rear seatback. When the hooks are connected, make sure the adjacent seatbelts are not caught.

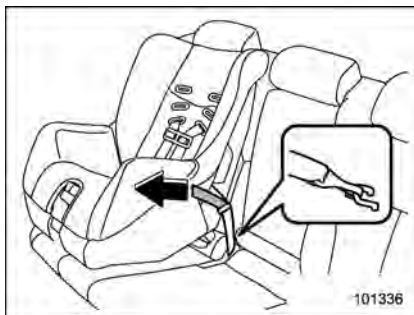

2. If your child restraint system is of a flexible attachment type (which uses tether belts to connect the child restraint system properly to the lower anchorages), while pushing the child restraint into the seat cushion, pull both left and right lower tether belts up to secure the child restraint system firmly by taking up the slack in the belt.

3. Connect the top tether hook to the tether anchorage and firmly tighten the tether. For information on how to set the top tether, refer to “Top tether anchorages” 1-35.

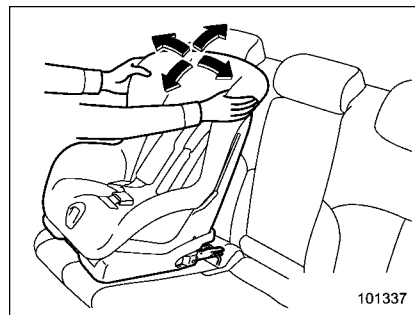

4. Before seating a child in the child restraint system, try to move it back and forth and left and right to verify that it is firmly secured in the center of the seat.

5. To remove the child restraint system, follow the reverse procedures of installation.

If you have any question concerning this type of child restraint system, ask your SUBARU dealer.

■ Top tether anchorages

Your vehicle is equipped with three top tether anchorages so that a child restraint system having a top tether can be installed in the rear seat. When installing a child restraint system using top tether, proceed as follows, while observing the

instructions by the child restraint system manufacturer.

Since a top tether can provide additional stability by offering another connection between a child restraint system and the vehicle, we recommend that you use a top tether whenever one is required or available.

▼ **Tether anchorage location**

▽ **Legacy**

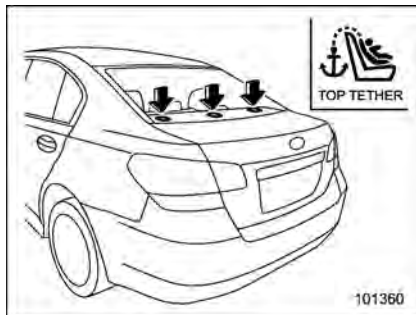

Three tether anchorages are installed on the rear shelf behind the rear seat head restraint. Open the cover flap to use each anchorage.

▽ **Outback**

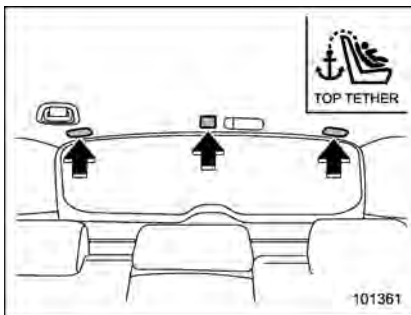

Three tether anchorages, i.e., ones for the right, center and left positions, are already installed on the rear edge of the roof. Open the cover flap to use each anchorage.

▼ **To hook the top tether**

| |
|---|
|  CAUTION |
| <p>Always remove the head restraint when mounting a child restraint system with a top tether. Failure to do so may prevent the top tether from being fastened tightly.</p> |

▽ **Legacy**

1. Fold down the rear seatback for the window side seating position. Refer to "Folding down the rear seatback" 1-8.

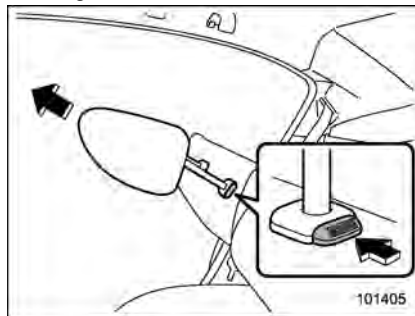

2. Remove the head restraint at the seating position where the child restraint system has been installed with the seatbelt or lower anchorages; lift up the head

restraint while pressing the release button. Store the head restraint in the trunk. Avoid placing the head restraint in the passenger compartment to prevent it from being thrown around in the passenger compartment in a sudden stop or a sharp turn.

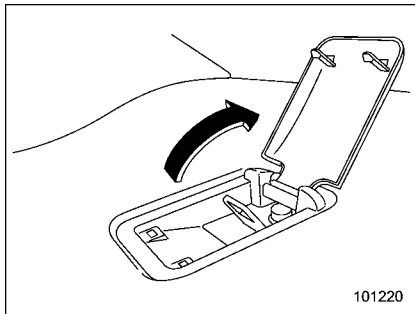

3. Open the cover flaps to use the anchorages.

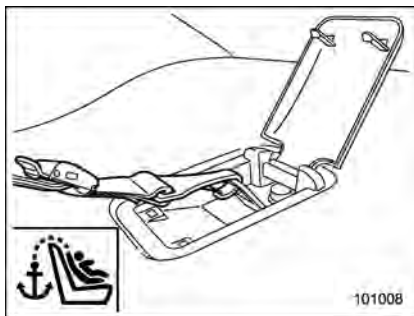

4. Fasten the top tether hook of the child restraint system to the appropriate upper anchorage.
5. Tighten the top tether securely.

▼ **Outback**

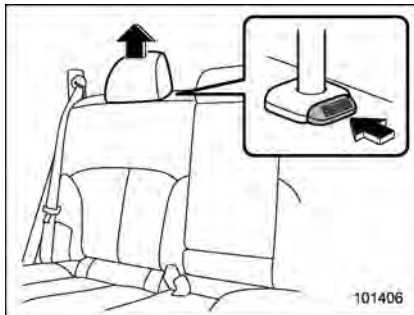

1. Remove the head restraint at the seating position where the child restraint system has been installed with the seatbelt or lower anchorages; lift up the head restraint while pressing the release button. Store the head restraint in the cargo area. Avoid placing the head restraint in the passenger compartment to prevent it from being thrown around in the passenger compartment in a sudden stop or a sharp turn.

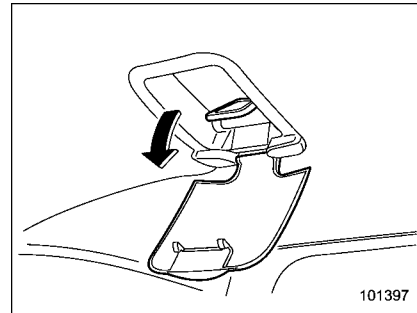

2. Open the cover flaps to use the anchorages.

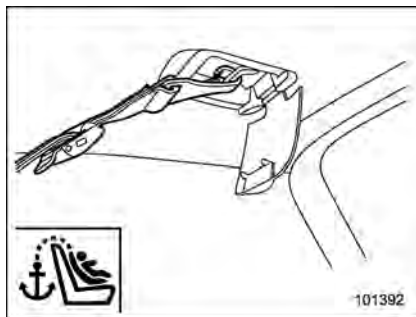

3. Fasten the top tether hook of the child restraint system to the appropriate upper anchorage.
4. Tighten the top tether securely.

*SRS airbag (Supplemental Restraint System airbag)

*SRS: This stands for supplemental restraint system. This name is used because the airbag system supplements the vehicle's seatbelts.

Your vehicle is equipped with a crash sensing and diagnostic module, which will record the use of the seatbelt by the front passenger when any of the SRS frontal, side and curtain airbags deploys.

■ Models with SRS airbags and lap/shoulder restraints for driver, front passenger, and window-side rear passengers

Your vehicle is equipped with a supplemental restraint system in addition to a lap/shoulder belt at each front seating position and each rear window-side seating position. The supplemental restraint system (SRS) consists of six airbags.

The configurations are as follows:

- Driver's and front passenger's **frontal** airbags
- Driver's and front passenger's **side** airbags
- **Curtain** airbags (for driver, front passenger, and window-side rear passen-

gers)

These SRS airbags are designed only as a supplement to the primary protection provided by the seatbelt.

The system also controls front seatbelt pretensioners. For operation instructions and precautions concerning the seatbelt pretensioner, refer to "Front seatbelt pretensioners" 1-22.

WARNING

- **To obtain maximum protection in the event of an accident, the driver and all passengers in the vehicle should always wear seatbelts when the vehicle is moving. The SRS airbag is designed only as a supplement to the primary protection provided by the seatbelt. It does not do away with the need to fasten seatbelts. In combination with the seatbelts, it offers the best combined protection in case of a serious accident. Not wearing a seatbelt increases the chance of severe injury or death in a crash even when the vehicle has the SRS airbag. For instructions and precautions concerning the seatbelt system,**

refer to “Seatbelts” 1-12.

- Do not sit or lean unnecessarily close to the SRS airbag. Because the SRS airbag deploys with considerable speed – faster than the blink of an eye – and force to protect in high speed collisions, the force of an airbag can injure an occupant whose body is too close to SRS airbag.

It is also important to wear your seatbelt to help avoid injuries that can result when the SRS airbag contacts an occupant not in proper position such as one thrown forward during pre-accident braking.

Even when properly positioned, there remains a possibility that an occupant may suffer minor injury such as abrasions and bruises to the face or arms because of the SRS airbag deployment force.

- The SRS airbags deploy with considerable speed and force. Occupants who are out of proper position when the SRS airbag deploys could suffer very serious injuries. Because the SRS airbag needs enough space for deploy-

ment, the driver should always sit upright and well back in the seat as far from the steering wheel as practical while still maintaining full vehicle control and the front passenger should move the seat as far back as possible and sit upright and well back in the seat.

- Do not place any objects over or near the SRS airbag cover or between you and the SRS airbag. If the SRS airbag deploys, those objects could interfere with its proper operation and could be propelled inside the vehicle and cause injury.



WARNING

- Put children in the rear seat properly restrained at all times. The SRS airbag deploys with considerable speed and force and can injure or even kill children, especially if they are not restrained or improperly restrained. Because children are lighter and weaker than adults, their risk of being injured from deployment is greater.

Consequently, we strongly recommend that ALL children (including those in child seats and those that have outgrown child restraint devices) sit in the REAR

seat properly restrained at all times in a child restraint device or in a seatbelt, whichever is appropriate for the child's age, height and weight.

Secure ALL types of child restraint devices (including forward facing child seats) in the REAR seats at all times.

According to accident statistics, children are safer when properly restrained in the rear seating positions than in the front seating positions.

For instructions and precautions concerning the child restraint system, refer to "Child restraint systems"  1-25.

- NEVER INSTALL A REARWARD FACING CHILD SEAT IN THE FRONT SEAT. DOING SO RISKS SERIOUS INJURY OR DEATH TO THE CHILD BY PLACING THE CHILD'S HEAD TOO CLOSE TO THE SRS AIRBAG.
- Never allow a child to stand up, or to kneel on the front passenger's seat, or never hold a child on your lap or in your arms. The SRS airbag deploys with considerable force and can injure or

even kill the child.



CAUTION

- When the SRS airbag deploys, some smoke will be released. This smoke could cause breathing problems for people with a history of asthma or other breathing trouble. If you or your passengers have breathing problems after SRS airbag deploys, get fresh air promptly.
- A deploying SRS airbag releases hot gas. Occupants could get burned if they come into direct contact with the hot gas.

NOTE

When you sell your vehicle, we urge you to explain to the buyer that it is equipped with SRS airbags by alerting him or her to the applicable section in this Owner's Manual.

▼ Components

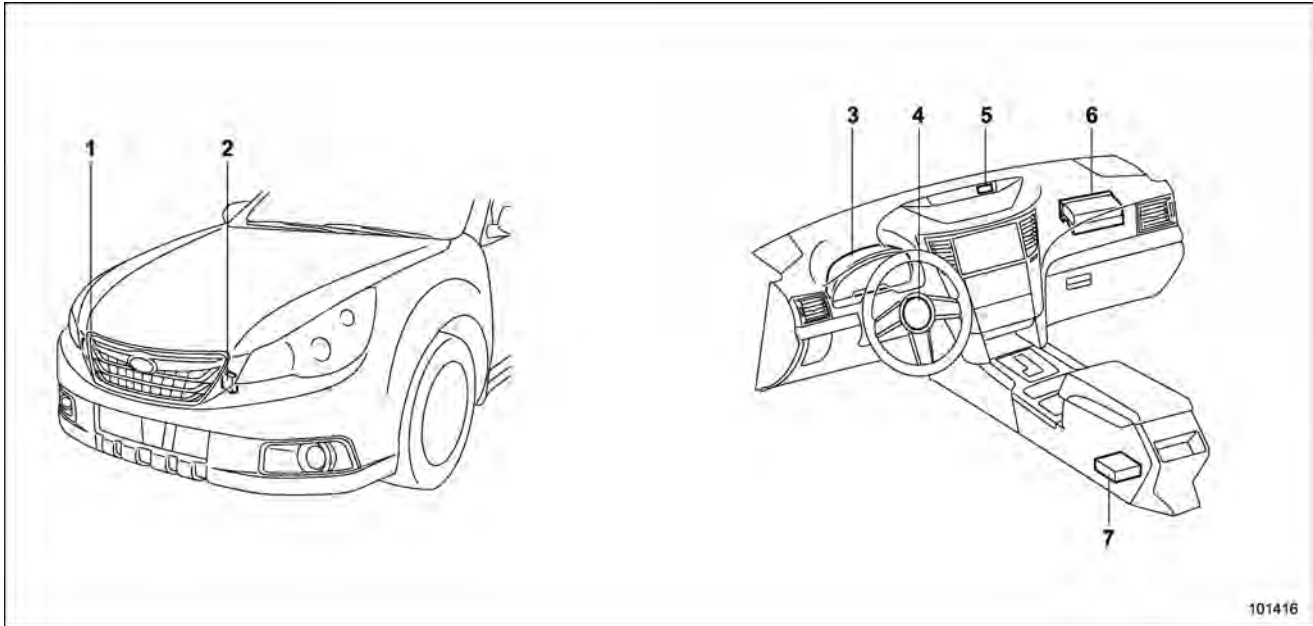

101416

- | | |
|--|--|
| 1) Front sub sensor (right-hand side) | 5) Front passenger's frontal airbag ON and OFF indicator |
| 2) Front sub sensor (left-hand side) | 6) Frontal airbag module (front passenger's side) |
| 3) SRS airbag system warning light | 7) Airbag control module (including impact sensor) |
| 4) Frontal airbag module (driver's side) | |

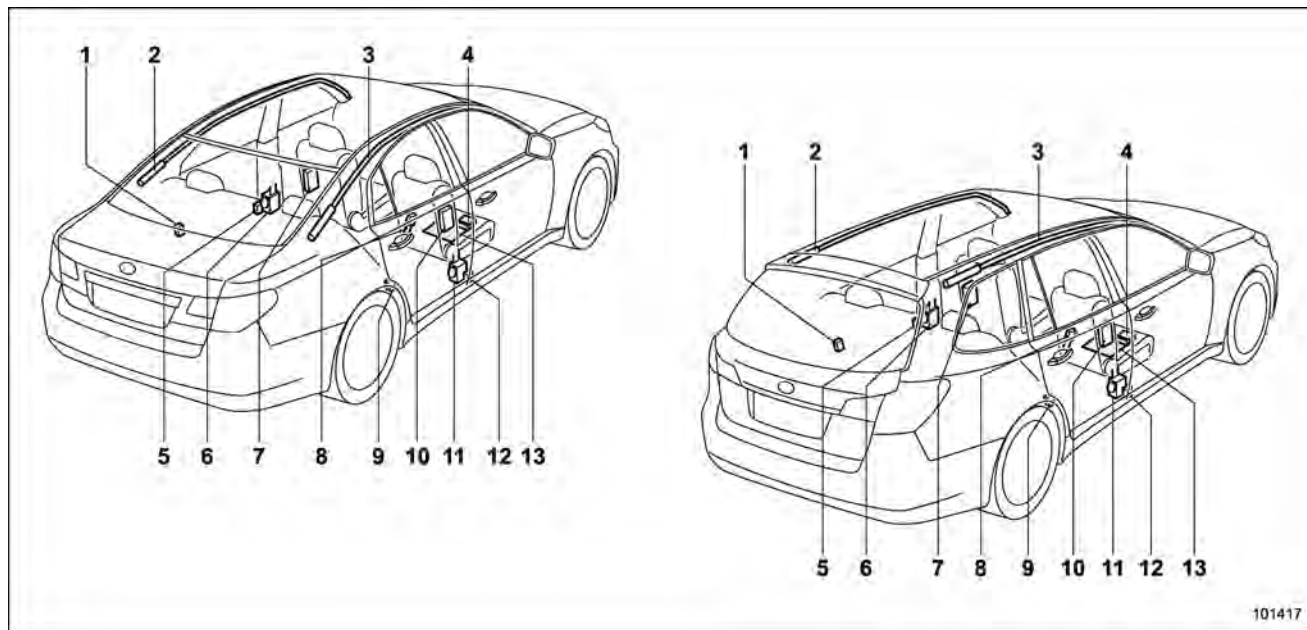

101417

- | | | |
|--|---|---|
| 1) Curtain airbag sensor (left-hand side) | 7) Side airbag module (left-hand side) | 13) Front passenger's occupant detection system weight sensor |
| 2) Curtain airbag module (left-hand side) | 8) Seatbelt buckle switch (right-hand side) | |
| 3) Curtain airbag module (right-hand side) | 9) Curtain airbag sensor (right-hand side) | |
| 4) Front passenger's occupant detection control module | 10) Side airbag module (right-hand side) | |
| 5) Side airbag sensor (left-hand side) | 11) Seatbelt pretensioner (right-hand side) | |
| 6) Seatbelt pretensioner (left-hand side) | 12) Side airbag sensor (right-hand side) | |

■ SUBARU advanced frontal airbag system

Your vehicle is equipped with a SUBARU advanced frontal airbag system that complies with the new advanced frontal airbag requirements in the amended Federal Motor Vehicle Safety Standard (FMVSS) No. 208.

The SUBARU advanced frontal airbag system automatically determines the deployment force of the driver's SRS frontal airbag at the time of deployment as well as whether or not to activate the front passenger's SRS frontal airbag and, if activated, the deployment force of the SRS frontal airbag at the time of deployment.

Your vehicle has warning labels on the driver's and front passenger's sun visors beginning with the phrase "EVEN WITH ADVANCED AIR BAGS" and a tag attached to the glove box lid beginning with the phrase "Even with Advanced Air Bags". Make sure that you carefully read the instructions on the warning labels and tag.

Always wear your seatbelt. The SUBARU advanced frontal airbag system is a supplemental restraint system and must be used in combination with a seatbelt. All occupants should wear a seatbelt or be seated in an appropriate child restraint

system.

The driver's SRS frontal airbag is stowed in the center portion of the steering wheel. The front passenger's SRS frontal airbag is stowed near the top of the dashboard under an "SRS AIRBAG" mark.

In a moderate to severe frontal collision, the driver's and front passenger's SRS frontal airbags deploy and supplement the seatbelts by reducing the impact on the driver's and front passenger's head and chest.



⚠ WARNING

NEVER INSTALL A REARWARD FACING CHILD SAFETY SEAT IN THE FRONT SEAT. DOING SO RISKS SERIOUS INJURY OR DEATH TO

THE CHILD BY PLACING THE CHILD'S HEAD TOO CLOSE TO THE SRS AIRBAG.

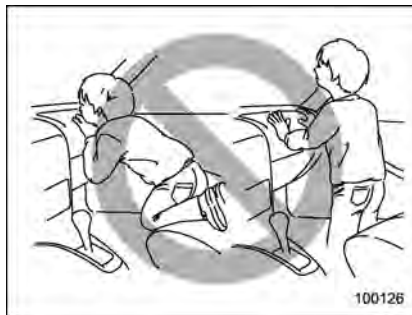

⚠ WARNING

Never allow a child to stand up, or to kneel on the front passenger's seat. The SRS airbag deploys with considerable force and can injure or even kill the child.



▲ WARNING

Never hold a child on your lap or in your arms. The SRS airbag deploys with considerable force and can injure or even kill the child.



▲ WARNING

The SRS airbag deploys with considerable speed and force. Occupants who are out of proper position when the SRS airbag deploys could suffer very serious injuries. Because the SRS airbag needs enough space for deployment, the driver should always sit upright and well back in the seat as far from the steering wheel as practical while still maintaining full vehicle control and the front passenger should move the seat as far back as possible and sit upright and well back in the seat.

It is also important to wear your

seatbelt to help avoid injuries that can result when the SRS airbag contacts an occupant not in proper position such as one thrown toward the front of the vehicle during pre-accident braking.

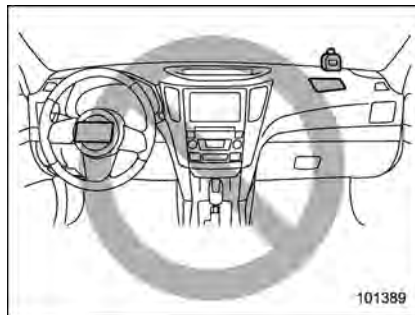

▲ WARNING

Do not put any objects over the steering wheel pad and dashboard. If the SRS frontal airbag deploys, those objects could interfere with its proper operation and could be propelled inside the vehicle and cause injury.

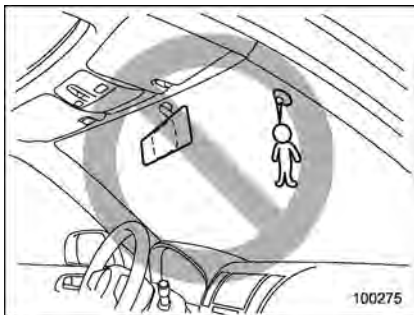

WARNING

Do not attach accessories to the windshield, or fit an extra-wide mirror over the rear view mirror. If the SRS airbag deploys, those objects could become projectiles that could seriously injure vehicle occupants.

▼ **Driver's SRS frontal airbag**

The driver's SRS frontal airbag uses a dual stage inflator. The inflator operates in different ways depending on the severity of impact.

Have the system inspected by your SUBARU dealer immediately if the SRS airbag system warning light illuminates.

NOTE

The driver's SRS side airbag, SRS curtain airbag and seatbelt pretensioner are not controlled by the SUBARU advanced frontal airbag system.

▼ **Front passenger's SRS frontal airbag**

The front passenger's SRS frontal airbag uses a dual stage inflator. The inflator operates in different ways depending on the severity of impact.

The total load on the seat is monitored by the passenger's occupant detection system weight sensor under the seat.

Using the total seat load and seatbelt buckle switch, the occupant detection system determines whether the front passenger's SRS frontal airbag should or should not be inflated.

The occupant detection system may not inflate the front passenger's SRS frontal airbag even when the driver's SRS frontal airbag deploys. This is normal.

Observe the following precautions. Failure to do so may prevent the SUBARU advanced frontal airbag system from functioning correctly or cause the system to fail.

- Do not apply any strong impact to the front passenger's seat such as by kicking.

- Do not spill liquid on the front passenger's seat. If liquid is spilled, wipe it off immediately.

- Do not remove or disassemble the front passenger's seat.

- Do not install any accessory (such as an audio amplifier) other than a genuine SUBARU accessory under the front passenger's seat.

- Do not place anything (shoes, umbrella, etc.) under the front passenger's seat.

- The front passenger's seat must not be used with the head restraint removed.

- Do not leave any articles on the front passenger's seat or the seatbelt tongue and buckle engaged when you leave your vehicle.

- Do not place a magnet near the seatbelt buckle and the seatbelt retractor.

- Do not use front seats with their backward-forward position and seatback not being locked into place securely. If any of them are not locked securely, adjust them again. For adjusting procedure, refer to "Manual seat" 1-3 (models equipped with manual seats only).

If the seatbelt buckle switch and/or front passenger's occupant detection system have failed, the SRS airbag system warning light will illuminate. Have the system inspected by your SUBARU dealer.

er immediately if the SRS airbag system warning light illuminates.

If your vehicle has sustained impact, this may affect the proper function of the SUBARU advanced frontal airbag system. Have your vehicle inspected at your SUBARU dealer.



NOTE

The front passenger's SRS side airbag, SRS curtain airbag and seatbelt pretensioner are not controlled by the SUBARU advanced frontal airbag system.

▼ Passenger's frontal airbag ON and OFF indicators



ON /  : Front passenger's frontal airbag ON indicator

 /  : Front passenger's frontal airbag OFF indicator

The front passenger's frontal airbag ON and OFF indicators show you the status of the front passenger's SRS frontal airbag.

The indicators are located next to the clock in the center portion of the dashboard.

When the ignition switch is turned to the "ON" position, both the ON and OFF indicators illuminate for 6 seconds during which time the system is checked. Following the system check, both indicators turn off for 2 seconds. After that, one of the indicators illuminates depending on the

status of the front passenger's SRS frontal airbag determined by the SUBARU advanced frontal airbag system monitoring.

If the front passenger's SRS frontal airbag is activated, the passenger's frontal airbag ON indicator will illuminate while the OFF indicator will remain off.

If the front passenger's SRS frontal airbag is deactivated, the passenger's frontal airbag ON indicator will remain off while the OFF indicator will illuminate.

With the ignition switch turned to the "ON" position, if both the ON and OFF indicators remain illuminated or off simultaneously even after the system check period, the system is malfunctioning. Contact your SUBARU dealer immediately for an inspection.

▼ Conditions in which front passenger's SRS frontal airbag is not activated

The front passenger's SRS frontal airbag will not be activated when any of the following conditions are met regarding the front passenger's seat:

- The seat is empty.
- The seat is equipped with a rearward facing child restraint system and an infant is restrained with it. (See WARNING that follows.)
- The seat is equipped with a forward

facing child restraint system and a small child is restrained with it. (See WARNING that follows.)

- The seat is equipped with a booster seat and a small child is in the booster seat. (See WARNING that follows.)
- The seat is relieved of the occupant load for a time exceeding the predetermined monitoring time period.
- The seat is occupied by a child who has outgrown a child restraint system (See WARNING that follows.) or by a small adult.
- The front passenger's occupant detection system is faulty.



WARNING

NEVER INSTALL A REARWARD FACING CHILD SEAT IN THE FRONT PASSENGER'S SEAT EVEN IF THE FRONT PASSENGER'S SRS FRONTAL AIRBAG IS DEACTIVATED. Be sure to install it in the REAR seat in a correct manner. Also, it is strongly recommended that any forward facing child seat or booster seat be installed in the REAR seat, and that even children who have outgrown a child restraint system be also seated in the REAR seat. This is because children sitting in the front

passenger's seat may be killed or severely injured should the front passenger's SRS frontal airbag deploy. REAR seats are the safest place for children.

When the front passenger's seat is occupied by a child, observe the following precautions. Failure to do so may increase the load on the front passenger's seat, activating the front passenger's SRS frontal airbag even though that seat is occupied by a child.

- Do not place any article on the seat other than the child occupant and a child restraint system.
- Do not place more than one child on the seat.
- Do not install any accessory such as a table or TV onto the seatback.
- Do not store a heavy load in the seatback pocket.
- Do not allow the rear seat occupant to place his/her hands or legs on the front passenger's seatback, or allow him/her to pull the seatback.

- ▽ **If the front passenger's frontal airbag ON indicator illuminates and the OFF indicator turns off even when an infant or a small child is in a child restraint system (including booster seat)**

Turn the ignition switch to the "LOCK" position if the front passenger's frontal airbag ON indicator illuminates and the OFF indicator turns off even when an infant or a small child is in a child restraint system (including booster seat). Remove the child restraint system from the seat. By referring to the child restraint manufacturer's recommendations as well as the child restraint system installation procedures in "Child restraint systems" 1-25, correctly install the child restraint system. Turn the ignition switch to the "ON" position and make sure that the front passenger's frontal airbag ON indicator turns off and the OFF indicator illuminates.

If still the ON indicator remains illuminated while the OFF indicator turns off, take the following actions.

- Ensure that no article is placed on the seat other than the child restraint system and the child occupant.
- Ensure that there is no article left in the seatback pocket.
- Ensure that the backward-forward po-

sition and seatback of front passenger's seat are locked into place securely by moving the seat back and forth. (Models equipped with manual seats only)

If the ON indicator still remains illuminated while the OFF indicator turns off after taking relevant corrective actions described above, relocate the child restraint system to the rear seat and immediately contact your SUBARU dealer for an inspection.

NOTE

When a child who has outgrown a child restraint system or a small adult is seated in the front passenger's seat, the SUBARU advanced frontal airbag system may or may not activate the front passenger's SRS frontal airbag depending on the occupant's seating posture. If the front passenger's SRS frontal airbag is activated (the ON indicator remains illuminated while the OFF indicator turns off), take the following actions.

- **Ensure that no article is placed on the seat other than the occupant.**
- **Ensure that there is no article left in the seatback pocket.**

If the ON indicator still remains illuminated while the OFF indicator turns off

despite the fact that the actions noted above have been taken, seat the child/small adult in the rear seat and immediately contact your SUBARU dealer for an inspection. Even if the system has passed the dealer inspection, it is recommended that on subsequent trips the child/small adult always take the rear seat.

Children who have outgrown a child restraint system should always wear the seatbelt irrespective of whether the airbag is deactivated or activated.

▼ Conditions in which front passenger's SRS frontal airbag is activated

The front passenger's SRS frontal airbag will be activated for deployment upon impact when any of the following conditions is met regarding the front passenger's seat.

- When the seat is occupied by an adult.
- When a heavy article is placed on the seat.

When the front passenger's seat is occupied by an adult, observe the following precautions. Failure to do so may lessen the load on the front passenger's seat, deactivating the front passenger's SRS frontal airbag despite the fact that the seat is occupied by an adult.

- Do not allow the rear seat occupant to lift the front passenger's seat cushion using his/her feet.
- Do not place any article under the front passenger's seat, or squeeze any article from behind and under the seat. This may lift the seat cushion.
- Do not squeeze any article between the front passenger's seat and side trim/pillar, door or center console box. This may lift the seat cushion.

▽ If the passenger's frontal airbag OFF indicator illuminates and the ON indicator turns off even when the front passenger's seat is occupied by an adult

This can be caused by the adult incorrectly sitting in the front passenger's seat. Turn the ignition switch to the "LOCK" position. Ask the front passenger to set the seatback to the upright position, sit up straight in the center of the seat cushion, correctly fasten the seatbelt, position his/her legs out forward, and adjust the seat to the rearmost position. Turn the ignition switch to the "ON" position. If the OFF indicator remains illuminated while the ON indicator remains off, take the following actions.

- Turn the ignition switch to the "LOCK" position.

- Ensure that there is no article, book, shoe, or other object trapped under the seat, at the rear of the seat, or on the side of the seat.
- Ensure that the backward-forward position and seatback of front passenger's seat are locked into place securely by moving the seat back and forth. (Models equipped with manual seats only)
- Next, turn the ignition switch to the "ON" position and wait 6 seconds to allow the system to complete self-checking. Following the system check, both indicators turn off for 2 seconds. Now, the ON indicator should illuminate while the OFF indicator remains off.

If the OFF indicator still remains illuminated while the ON indicator remains off, ask the occupant to move to the rear seat and immediately contact your SUBARU dealer for an inspection.

▼ **Effect vehicle modifications made for persons with disabilities may have on SUBARU advanced frontal airbag system operation (U.S. only)**

Changing or moving any parts of the front seats, seat belts, front bumper, front side frame, instrument panel, combination meter, steering wheel, steering column, tire, suspension or floor panel can affect the operation of the SUBARU advanced air-

bag system. If you have any questions, you may contact the following SUBARU distributors:

<Continental U.S., Alaska and the District of Columbia>

Subaru of America, Inc.

Customer Dealer Services Department
P.O. Box 6000

Cherry Hill, NJ 08034-6000

1-800-SUBARU3 (1-800-782-2783)

<Hawaii>

Servco Subaru Inc., dba Subaru Hawaii
2850 Pukoloa Street, Suite 202, Honolulu, HI 96819

808-839-2273

<Guam>

Shen's Corporation dba Prestige Automobile

491, East Marine Drive, Route 1 Dededo, Guam

671-633-2698

<Puerto Rico>

Trebol Motors

P.O. Box 11204, San Juan, Puerto Rico 00910

787-793-2828

There are currently no SUBARU distributors in any other U.S. territories. If you are

in such an area, please contact the SUBARU distributor or dealer from which you bought your vehicle.

▼ **Operation**

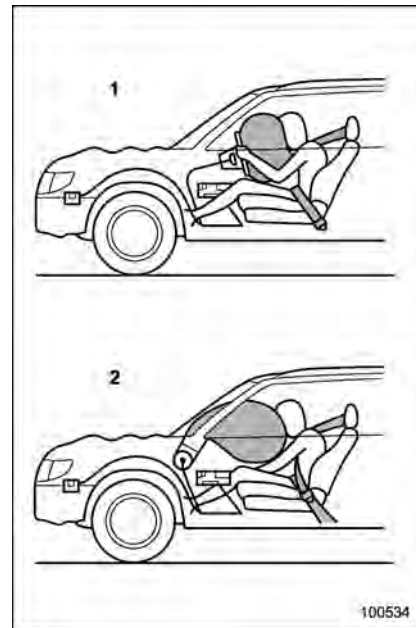

- 1) Driver's side
- 2) Passenger's side

The SRS airbag can function only when the ignition switch is in the "ON" position. The SUBARU advanced frontal airbag system is designed to determine the activation or deactivation condition of the front passenger's SRS frontal airbag depending on the total load on the front passenger's seat monitored by the front passenger's occupant detection system weight sensor. For this reason, only the driver's SRS frontal airbag may deploy in the event of a collision, but this does not mean failure of the system.

If the front sub sensors inside both front fenders and the impact sensors in the airbag control module detect a predetermined amount of force during a frontal collision, the control module sends signals to the airbag module(s) (only driver's module or both driver's and front passenger's modules) instructing the module(s) to inflate the SRS frontal airbag(s). The driver's and front passenger's SRS frontal airbags use dual stage inflators. The two inflators of each airbag are triggered either sequentially or simultaneously, depending on the severity of impact in the case of the driver's SRS frontal airbag and depending on the severity of impact and the total load on the seat in the case of the front passenger's SRS frontal airbag.

After deployment, the SRS airbag immediately starts to deflate so that the driver's vision is not obstructed. The time required from detecting impact to the deflation of the SRS airbag after deployment is shorter than the blink of an eye.

Both when only the driver's SRS frontal airbag deploys and the driver's and front passenger's SRS frontal airbags deploy, the driver's and front passenger's seatbelt pretensioners operate at the same time.

Although it is highly unlikely that the SRS airbag would activate in a non-accident situation, should it occur, the SRS airbag will deflate quickly, not obscuring vision and will not interfere with the driver's ability to maintain control of the vehicle.

When the SRS airbag deploys, a sudden, fairly loud inflation noise will be heard and some smoke will be released. These occurrences are a normal result of the deployment. This smoke does not indicate a fire in the vehicle.

**CAUTION**

Do not touch the SRS airbag system components around the steering wheel and dashboard with bare hands right after deployment. Doing so can cause burns because the

components can be very hot as a result of deployment.

The driver's SRS frontal airbag and front passenger's SRS frontal airbag are designed to deploy in the event of an accident involving a moderate to severe frontal collision. It is basically not designed to deploy in lesser frontal impacts because the necessary protection can be achieved by the seatbelt alone. Also, they are basically not designed to deploy in side or rear impacts or in roll-over accidents because deployment of only the driver's SRS frontal airbag or both driver's and front passenger's SRS frontal airbags would not help the occupant in those situations. The driver's and front passenger's SRS frontal airbags are designed to function on a one-time-only basis.

SRS airbag deployment depends on the level of force experienced in the passenger compartment during a collision. That level differs from one type of collision to another, and it may have no bearing on the visible damage done to the vehicle itself.

- ▽ Examples of accident in which the driver's/driver's and front passenger's SRS frontal airbag(s) will most likely deploy.

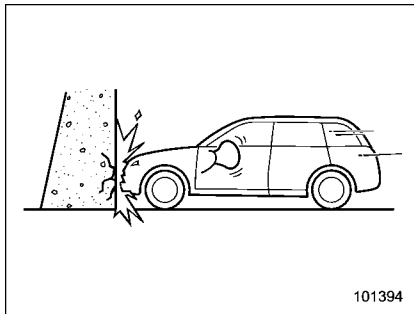

A head-on collision against a thick concrete wall at a vehicle speed of 12 to 19 mph (20 to 30 km/h) or higher activates only the driver's SRS frontal airbag or both driver's and front passenger's SRS frontal airbags. The airbag(s) will also be activated when the vehicle is exposed to a frontal impact similar in fashion and magnitude to the collision described above.

- ▽ Examples of the types of accidents in which it is possible that the driver's/driver's and front passenger's SRS frontal airbag(s) will deploy.

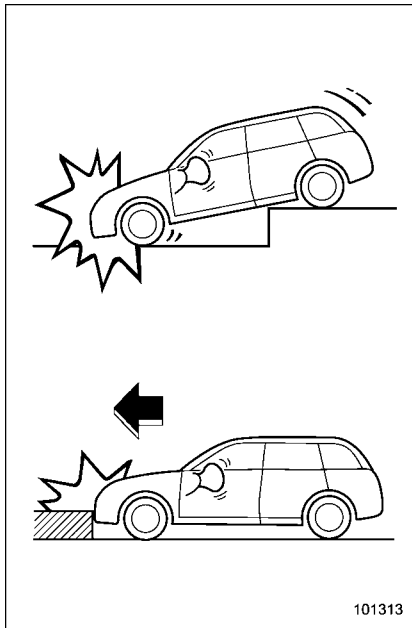

Only the driver's SRS frontal airbag or

both driver's and front passenger's SRS frontal airbags may be activated when the vehicle sustains a hard impact in the undercarriage area from the road surface (such as when the vehicle plunges into a deep ditch, is severely impacted or knocked hard against an obstacle on the road such as a curb).

▽ **Examples of the types of accidents in which deployment of the driver's/driver's and front passenger's SRS frontal airbag(s) is unlikely to occur.**

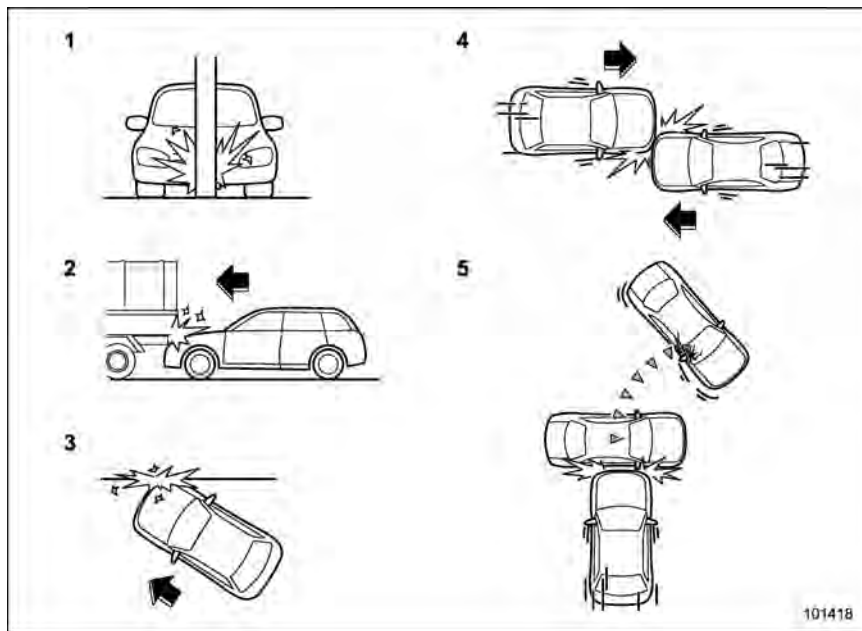

- 1) The vehicle strikes an object, such as a telephone pole or sign pole.
- 2) The vehicle slides under the load bed of a truck.
- 3) The vehicle sustains an oblique offset frontal impact.
- 4) The vehicle sustains an offset frontal collision.
- 5) The vehicle strikes an object that can move or deform, such as a parked vehicle.

There are many types of collisions which might not necessarily require deployment of driver's/driver's and front passenger's SRS frontal airbag(s). In the event of accidents like those illustrated, the driver's/driver's and front passenger's SRS frontal airbag(s) may not deploy depending on the level of accident forces involved.

- ▽ Examples of the types of accidents in which the driver's/driver's and front passenger's SRS frontal airbag(s) will basically not deploy.

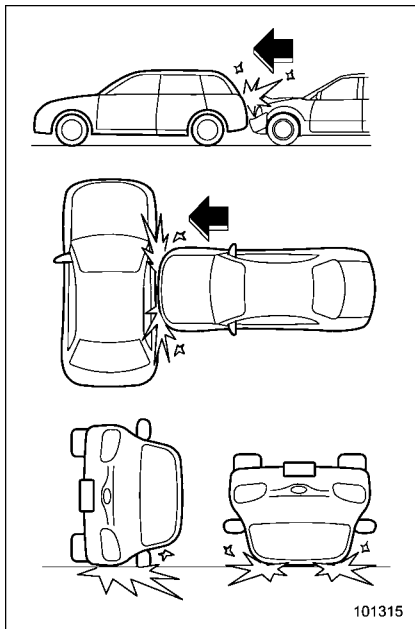

The driver's and front passenger's SRS frontal airbags are designed basically not

to deploy if the vehicle is struck from the side or from behind, or if it rolls onto its side or roof, or if it is involved in a low-speed frontal collision.

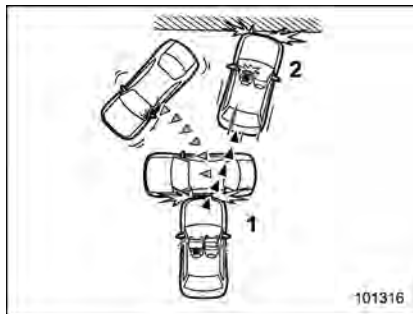

- 1) First impact
- 2) Second impact

In an accident where the vehicle is impacted more than once, the driver's and/or front passenger's SRS frontal airbag(s) will deploy only once on the first impact.

Example: In the case of a double collision, first with another vehicle, then against a concrete wall in immediate succession, once either or both of the driver's and front passenger's SRS frontal airbags is/are activated on the first impact, it/they will not be activated on the second impact.

⚠ WARNING

If the vehicle is damaged in an accident but the SRS frontal airbag does not deploy, contact your SUBARU dealer as soon as possible.

■ SRS side airbag and SRS curtain airbag

The SRS side airbag is stored in the door side of each front seat seatback, which bears an "SRS AIRBAG" label.

In a moderate to severe side impact collision, the SRS side airbag on the impacted side of the vehicle deploys between the occupant and the door panel and supplements the seatbelt by reducing the impact on the occupant's chest and waist. The SRS side airbag operates only for front seat occupants.

The SRS curtain airbag on each side of the cabin is stored in the roof side (between the front pillar and a point over the rear seat). An "SRS AIRBAG" mark is located at the top of each center pillar.

In a moderate to severe side impact collision, the SRS curtain airbag on the impacted side of the vehicle deploys between the occupant and the side

window and supplements the seatbelt by reducing the impact on the occupant's head.

▲ WARNING

The SRS side airbag and SRS curtain airbag are designed as only a supplement to the primary protection provided by the seatbelt. They do not do away with the need to fasten seatbelts. It is also important to wear your seatbelt to help avoid injuries that can result when an occupant is not seated in a proper upright position.



▲ WARNING

- Do not sit or lean unnecessarily close to either front door. The SRS side airbag is stored in both front seat seatbacks next to the door, and it provides protection by deploying rapidly (faster than the blink of an eye) in the event of a side impact collision. However, the force of SRS side airbag deployment may cause injuries if your head or other parts of the body are too close to the SRS side airbag.

- Since your vehicle is equipped with SRS curtain airbags, do not sit or lean unnecessarily close to the front or rear door on either side. Also, do not put your head, arms and hands out of the window. The SRS curtain airbag on each side of the cabin is stored in the roof side (between the front pillar and a point over the rear seat), and it provides protection by deploying rapidly (faster than the blink of an eye) in the event of a side impact. However, the force of its deployment may cause injuries if your head is too close to it.



WARNING

Do not rest your arm on either front door or its internal trim. It could be injured in the event of SRS side airbag deployment.

**WARNING**

- Never allow a child to kneel on the front passenger's seat facing the side window or to wrap his/her arms around the front seat seatback. In the event of an accident, the force of the SRS side airbag deployment could injure the child seriously because his/her head or arms or other parts of the body are too close to the SRS side airbag.

Since your vehicle is also equipped with a front passenger's SRS frontal airbag, children aged 12 and under should be placed in the rear seat anyway

and should be properly restrained at all times.

- Never allow a child to kneel on any passenger's seat facing the side window or put their head, arms and hands out of the window. In the event of an accident, the force of the SRS curtain airbag deployment could injure the child seriously because his/her head is close to the SRS curtain airbag.

**WARNING**

- Do not attach accessories to the door trim or near either SRS side airbags and do not place objects

near the SRS side airbags. In the event of the SRS side airbag deployment, they could be propelled dangerously toward the vehicle's occupants and cause injuries.

- Do not attach a hands-free microphone or any other accessory to a front pillar, a center pillar, a rear pillar, the windshield, a side window, an assist grip, or any other cabin surface that would be near a deploying SRS curtain airbag. A hands-free microphone or other accessory in such a location could be propelled through the cabin with great force by the curtain airbag, or it could prevent correct deployment of the curtain airbag. In either case, the result could be serious injuries.
- Do not hang coat hangers or other hard or pointed objects on the coat hooks. If such items were hanging on the coat hooks during deployment of the SRS curtain airbags, they could cause serious injuries by coming off the coat hooks and being thrown through the cabin or by preventing deployment of the curtain airbags.

Before hanging clothing on the coat hooks, make sure there are no sharp objects in the pockets. Hang clothing directly on the coat hooks without using hangers.

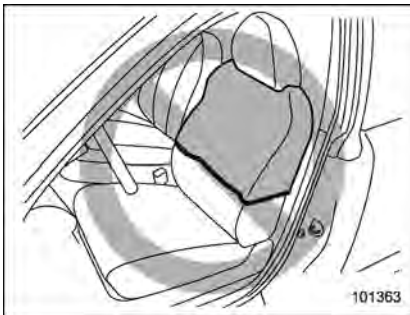

WARNING

Do not put any kind of cover or clothes or other objects over either front seatback and do not attach labels or stickers to the front seat surface on or near the SRS side airbag. They could prevent proper deployment of the SRS side airbag, reducing protection available to the front seat's occupant.

▼ Operation



The SRS side airbag and SRS curtain airbag can function only when the ignition switch is in the "ON" position.

The driver's and front passenger's SRS side airbags and SRS curtain airbags deploy independently of each other since each has its own impact sensor. Therefore, they may not both deploy in the same accident. Also, the SRS side airbag and SRS curtain airbag deploys independently of the driver's and front passenger's SRS frontal airbags in the steering wheel and instrument panel.

An impact sensor, which senses impact force, is located in each of the left and right center pillars and rear wheel houses. Another impact sensor, which also senses

impact force, is located in the airbag control module.

If one of the center pillar impact sensors and the impact sensor that is located in the airbag control module together sense an impact force above a predetermined level in a side collision, the control module causes both the SRS side airbag and curtain airbag on the impacted side to inflate regardless of whether the rear wheel house impact sensor on the same side senses an impact.

If one of the rear wheel house impact sensors and the impact sensor that is located in the airbag control module together sense a sufficiently strong impact force, the control module causes only the SRS curtain airbag on the impacted side to inflate.

After the deployment, the SRS side airbag immediately starts to deflate. The time required from detection of an impact to deflation of an SRS side airbag after deployment is shorter than the blink of an eye.

The SRS curtain airbag remains inflated for a while following deployment then slowly deflates.

The SRS side airbag and SRS curtain airbag deploy even when no one occupies

the seat on the side on which an impact is applied.

When the SRS side airbag and SRS curtain airbag deploy, a sudden, fairly loud inflation noise will be heard and some smoke will be released. These occurrences are a normal result of the deployment. This smoke does not indicate a fire in the vehicle.

 **CAUTION**

Do not touch the SRS side airbag system components around the front seat seatback with bare hands right after deployment. Doing so can cause burns because the components can be very hot as a result of deployment.

After deployment, do not touch any part of the SRS curtain airbag system (from the front pillar to the part of the roof side over the rear seat). Doing so can cause burns because the components can be very hot as a result of deployment.

The SRS side airbag and SRS curtain airbag are designed to deploy in the event of an accident involving a moderate to severe side impact collision. It is basically not designed to deploy in a lesser side

impact. Also, it is basically not designed to deploy in frontal or rear impacts because SRS side airbag and SRS curtain airbag deployment would not help the occupant in those situations.

Each SRS side airbag and SRS curtain airbag are designed to function on a one-time-only basis.

SRS side airbag and SRS curtain airbag deployment depend on the level of force experienced in the passenger compartment during a side impact collision. That level differs from one type of collision to another, and it may have no bearing on the visible damage done to the vehicle itself.

- ▽ Example of the type of accident in which the SRS side airbag and SRS curtain airbag will most likely deploy (Legacy).

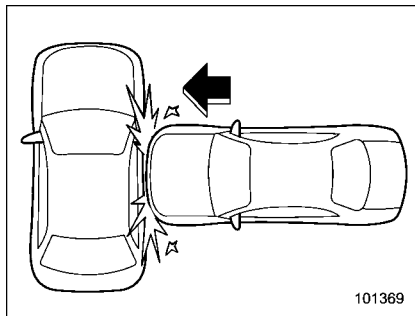

A severe side impact near the front seat activates the SRS side airbag and SRS curtain airbag.

▽ Examples of the types of accidents in which the SRS curtain airbag will most likely deploy (Outback).

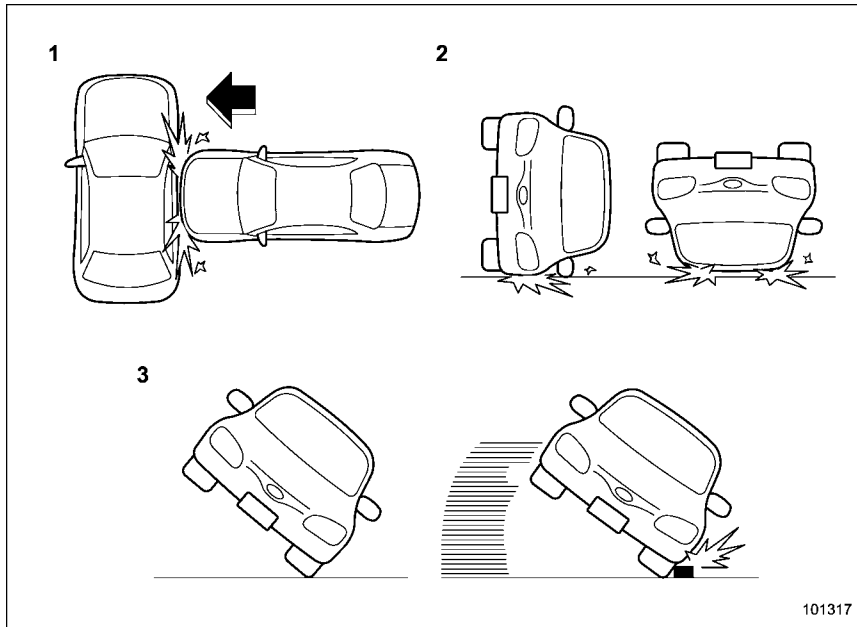

- 1) A severe side impact near the front seat or the rear seat activates the SRS curtain airbag.
- 2) The vehicle rolls onto its side or the roof.
- 3) If the angle of vehicle tip-up is marginal or if the skidding vehicle's tires hit a curbstone laterally.

▽ **Examples of the types of accidents in which it is possible that the SRS side airbag and the SRS curtain airbag will deploy (Outback).**

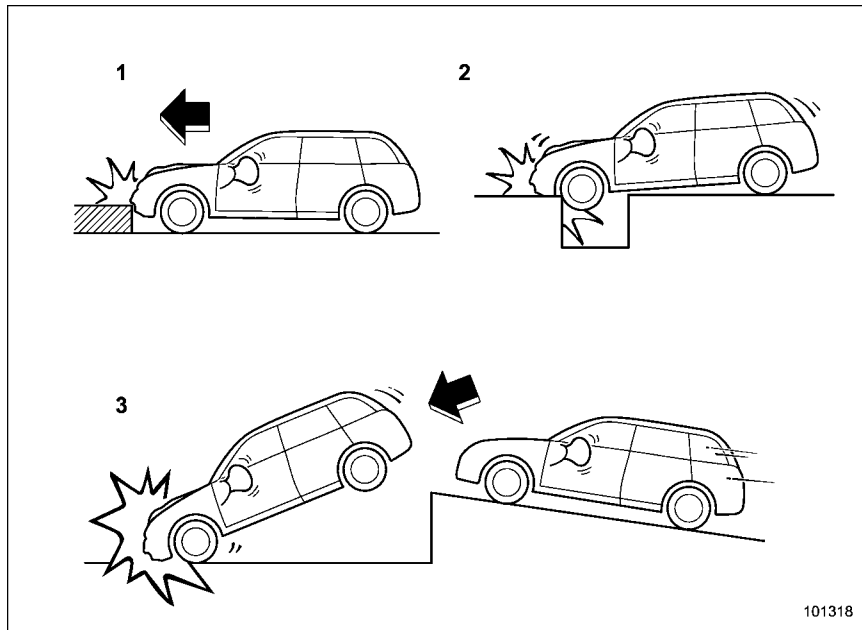

- 1) Hitting a curb, edge of pavement or hard surface
- 2) Falling into or jumping over a deep hole
- 3) Landing hard or vehicle falling

It is possible that the SRS side and curtain airbags will deploy if a serious impact occurs to the underside of your vehicle. Some examples are shown in the illustration.

▽ Examples of the types of accidents in which the SRS side airbag and SRS curtain airbag are unlikely to deploy.

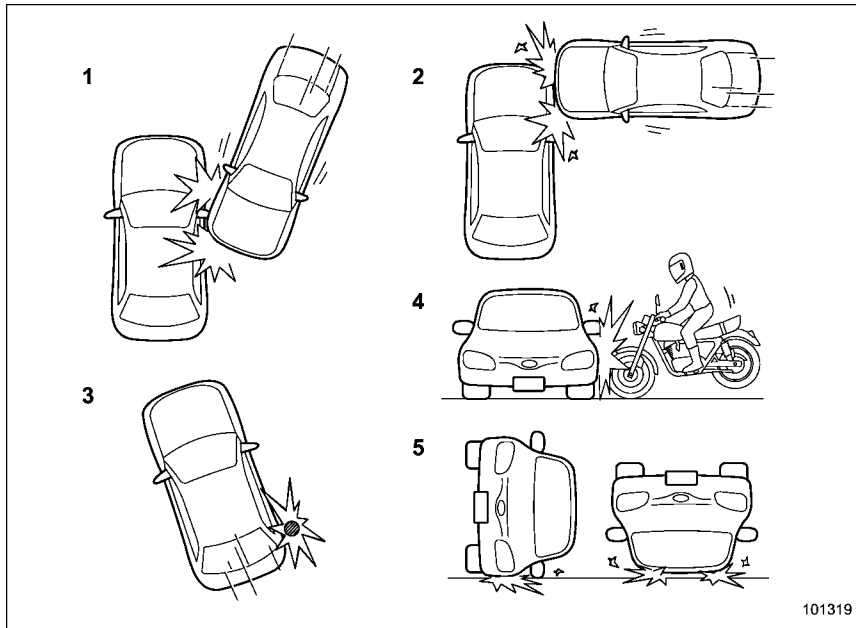

- 1) The vehicle is involved in an oblique side-on impact.
- 2) The vehicle is involved in a side-on impact in an area outside the vicinity of the passenger compartment.
- 3) The vehicle strikes a telephone pole or similar object.
- 4) The vehicle is involved in a side-on impact from a motorcycle.
- 5) The vehicle rolls onto its side or roof.

There are many types of collisions which might not necessarily require SRS side airbag and SRS curtain airbag deployment. In the event of accidents like those illustrated, the SRS side airbag and SRS curtain airbag may not deploy depending on the level of accident forces involved.

▽ **Examples of the types of accidents in which the SRS side airbag and SRS curtain airbag will basically not deploy.**

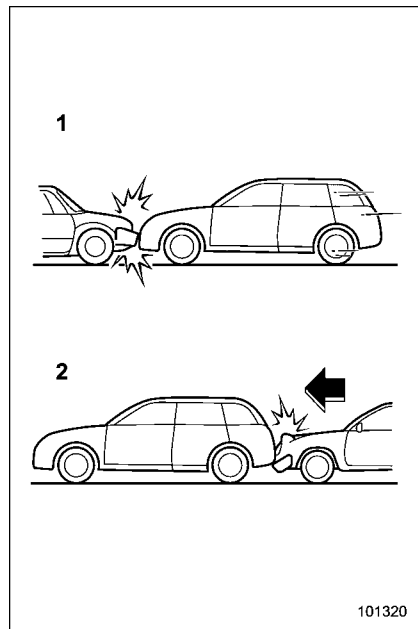

- 1) The vehicle is involved in frontal collision with another vehicle (moving or stationary).

- 2) The vehicle is struck from behind.

The SRS side airbag and SRS curtain airbag are basically not designed to deploy if the vehicle is involved in a frontal collision or is struck from behind. Examples of such accidents are illustrated.

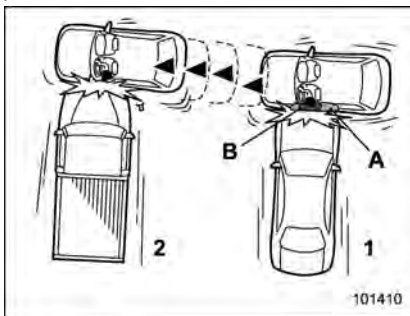

- 1) First impact
- 2) Second impact
- A) SRS curtain airbag
- B) SRS side airbag

In an accident where the vehicle is struck from the side more than once, the SRS side airbag and SRS curtain airbag deploy only once on the first impact.

Example: In the case of a double side impact collision, first with one vehicle and immediately followed by another from the same direction, once the SRS side airbag

and SRS curtain airbag are activated on the first impact, they will not be activated on the second.

■ **SRS airbag system monitors**

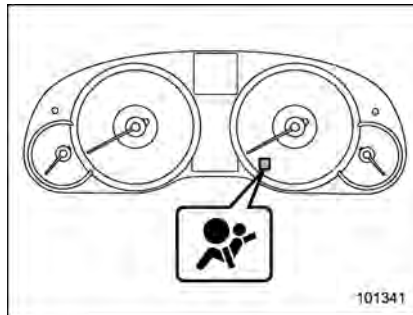

A diagnostic system continually monitors the readiness of the SRS airbag system (including front seatbelt pretensioners) while the vehicle is being driven. The SRS airbag system warning light "AIR-BAG" will show normal system operation by lighting for approximately 6 seconds when the ignition switch is turned to the "ON" position.

The following components are monitored by the indicator.

- Front sub sensor (right-hand side)
- Front sub sensor (left-hand side)

- Airbag control module (including impact sensors (all models) and rollover sensors (Outback))
- Frontal airbag module (driver's side)
- Frontal airbag module (front passenger's side)
- Side airbag sensor (center pillar right-hand side)
- Side airbag sensor (center pillar left-hand side)
- Side airbag module (driver's side)
- Side airbag module (front passenger's side)
- Curtain airbag sensor (rear wheel house right-hand side)
- Curtain airbag sensor (rear wheel house left-hand side)
- Curtain airbag module (right-hand side)
- Curtain airbag module (left-hand side)
- Seatbelt pretensioner (driver's side)
- Seatbelt pretensioner (front passenger's side)
- Seatbelt buckle switch (front passenger's side)
- Front passenger's occupant detection system weight sensor
- Front passenger's occupant detection control module
- Front passenger's frontal airbag ON and OFF indicator

- All related wiring

**WARNING**

If the warning light exhibits any of the following conditions, there may be a malfunction in the seatbelt pretensioners and/or SRS airbag system. Immediately take your vehicle to your nearest SUBARU dealer to have the system checked. Unless checked and properly repaired, the seatbelt pretensioners and/or SRS airbags will operate improperly (e.g. SRS airbags may inflate in a very minor collision or not inflate in a severe collision), which may increase the risk of injury.

- Flashing or flickering of the warning light
- No illumination of the warning light when the ignition switch is first turned to the "ON" position
- Continuous illumination of the warning light
- Illumination of the warning light while driving

**WARNING**

- When discarding an airbag module or scrapping the entire vehicle damaged by a collision, consult your SUBARU dealer.
- The SRS airbag has no user-serviceable parts. Do not use electrical test equipment on any circuit related to the SRS airbag system. For required servicing of the SRS airbag, consult your nearest SUBARU dealer. Tampering with or disconnecting the system's wiring could result in accidental inflation of the SRS airbag or could make the system inoperative, which may result in serious injury.

**CAUTION**

If you need service or repair in areas of your vehicle listed in the following, have an authorized SUBARU dealer perform the work. The SRS airbag control module, impact sensors and airbag modules are stored in these areas.

- Under the center console
- Inside each front fender
- Steering wheel and column and nearby areas
- Top of the dashboard on front passenger's side and nearby areas
- Each front seat and nearby area
- Inside each center pillar
- In each roof side (from the front pillar to a point over the rear seat)
- Between the rear seat cushion and rear wheel house on each side
- Under the rear center seat

In the event that the SRS airbag is deployed, replacement of the system should be performed only by an authorized SUBARU dealer. When the components of the SRS airbag system are

replaced, use only genuine SUBARU parts.

NOTE

In the following cases, contact your SUBARU dealer as soon as possible.

- The front part of the vehicle was involved in an accident in which only the driver's SRS frontal airbag or both driver's and front passenger's SRS frontal airbags did not deploy.
- The pad of the steering wheel, the cover over the front passenger's SRS frontal airbag, or either roof side (from the front pillar to a point over the rear seat) is scratched, cracked, or otherwise damaged.
- The center pillar, rear wheel house or rear sub frame, or an area near these parts, was involved in an accident in which the SRS side airbag and SRS curtain airbag did not deploy.
- The fabric or leather of either front seatback is cut, frayed, or otherwise damaged.
- The rear part of the vehicle was involved in an accident.

■ Precautions against vehicle modification**WARNING**

To avoid accidental activation of the system or rendering the system inoperative, which may result in serious injury, no modifications should be made to any components or wiring of the SRS airbag system.

This includes the following modifications:

- Installation of custom steering wheels
- Attachment of additional trim materials to the dashboard
- Installation of custom seats
- Replacement of seat fabric or leather
- Installation of additional fabric or leather on the front seat
- Attachment of a hands-free microphone or any other accessory to a front pillar, a center pillar, a rear pillar, the windshield, a side window, an assist grip, or any other cabin surface that would be near a deploying SRS curtain airbag.

- Installation of additional electrical/electronic equipment such as a mobile two-way radio on or near the SRS airbag system components and/or wiring is not advisable. This could interfere with proper operation of the SRS airbag system.

**CAUTION**

Do not perform any of the following modifications. Such modifications can interfere with proper operation of the SRS airbag system.

- Attachment of any equipment (bush bar, bullbar, winches, snow plow, skid/sump plate, etc.) other than genuine SUBARU accessory parts.
- Modification of the suspension system or front end structure.
- Installation of a tire of different size and construction from the tires specified on the vehicle placard attached to the driver's door pillar or specified for individual vehicle models in this Owner's Manual.
- Attachment of any equipment (side steps or side sill protectors,

etc.) other than genuine SUBARU accessory parts to the side body.

Always consult your SUBARU dealer if you want to install any accessory parts on your vehicle.

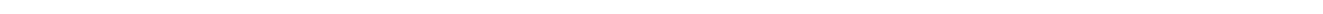
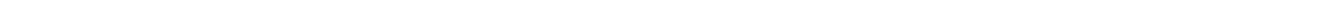
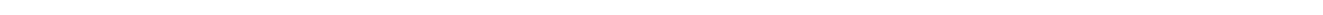
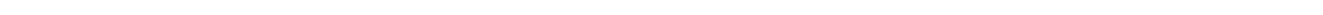
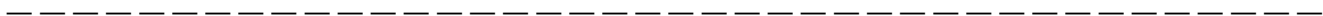
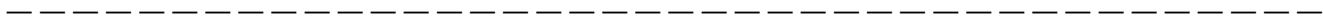

| | |
|--|------|
| Keys | 2-2 |
| Key number | 2-2 |
| Immobilizer | 2-3 |
| Security ID plate..... | 2-3 |
| Security indicator light | 2-4 |
| Key replacement | 2-4 |
| Door locks | 2-5 |
| Locking and unlocking from the outside | 2-5 |
| Locking and unlocking from the inside | 2-6 |
| Battery drainage prevention function | 2-6 |
| Power door locking switches | 2-7 |
| Key lock-in prevention function | 2-7 |
| Remote keyless entry system | 2-8 |
| Locking the doors | 2-9 |
| Unlocking the doors | 2-9 |
| Opening the trunk lid (Legacy)..... | 2-10 |
| Unlocking the rear gate (Outback)..... | 2-10 |
| Vehicle finder function..... | 2-10 |
| Sounding a panic alarm..... | 2-10 |
| Selecting audible signal operation | 2-11 |
| Replacing the battery | 2-11 |
| Replacing lost transmitters | 2-12 |
| Alarm system | 2-16 |
| System alarm operation..... | 2-16 |

| | |
|---|------|
| Activating and deactivating the alarm system | 2-16 |
| If you have accidentally triggered the alarm system | 2-16 |
| Arming the system | 2-17 |
| Disarming the system | 2-18 |
| Valet mode | 2-18 |
| Passive arming..... | 2-18 |
| Tripped sensor identification | 2-19 |
| Shock sensors (dealer option)..... | 2-19 |
| Child safety locks | 2-20 |
| Windows | 2-21 |
| Power window operation by driver | 2-21 |
| Power window operation by passengers..... | 2-23 |
| Initialization of power window | 2-24 |
| Trunk lid (Legacy) | 2-24 |
| To open and close the trunk lid from outside..... | 2-24 |
| To open the trunk lid from inside..... | 2-24 |
| Internal trunk lid release handle | 2-25 |
| Rear gate (Outback) | 2-27 |
| Moonroof (if equipped) | 2-28 |
| Moonroof switches | 2-29 |
| Sun shade | 2-30 |

Keys

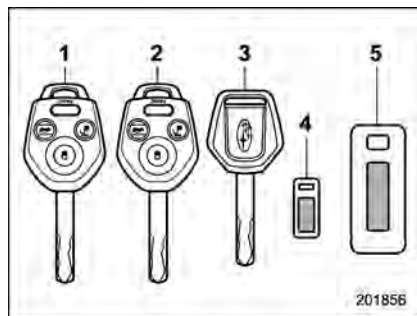

- 1) Master key
- 2) Submaster key
- 3) Valet key
- 4) Key number plate
- 5) Security ID plate

Three types of keys are provided for your vehicle:

Master key, submaster key and valet key.

The master key and submaster key fit all locks on your vehicle.

- Ignition switch
- Driver's door
- Glove box
- Trunk lid

The valet key fits only the ignition switch

and door locks. You can keep the trunk and glove box locked when you leave your vehicle and valet key at a parking facility.

CAUTION

Do not attach a large key holder or key case to either key. If it bangs against your knees while you are driving, it could turn the ignition switch from the "ON" position to the "Acc" or "LOCK" position, thereby stopping the engine.

■ Key number

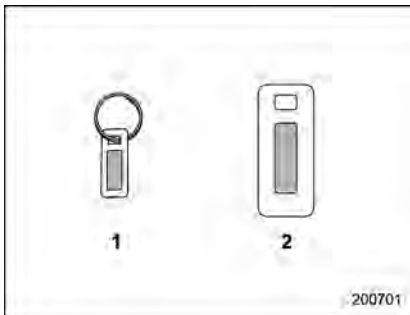

- 1) Key number plate
- 2) Security ID plate

The key number is stamped on the key

number plate attached to the key set. Write down the key number and keep it in another safe place, not in the vehicle. This number is needed to make a replacement key if you lose your key or lock it inside the vehicle.

For information on making replacement keys for models with the immobilizer system, refer to "Security ID plate" 2-3.

Immobilizer

The immobilizer system is designed to prevent an unauthorized person from starting the engine. Only keys registered with your vehicle's immobilizer system can be used to operate your vehicle. Even if an unregistered key fits into the ignition switch and can be turned to the "START" position, the engine will automatically stop after several seconds.

Each immobilizer key contains a transponder in which the key's ID code is stored. When a key is inserted into the ignition switch and turned to the "ON" position, the transponder transmits the key's ID code to the immobilizer system's receiver. If the transmitted ID code matches the ID code registered in the immobilizer system, the system allows the engine to be started. Since the ID code is transmitted and acted upon almost instantly, the immobilizer system does not impede normal starting of the engine.

If the engine does not start, pull out the key once before trying again. Refer to "Ignition switch" 3-3.

This device complies with Part 15 of the FCC Rules and with RSS-210 of Industry Canada. Operation is subject to the following two conditions: (1) This

device may not cause harmful interference, and (2) this device must accept any interference received, including interference that may cause undesired operation.

Changes or modifications not expressly approved by the party responsible for compliance could void the user's authority to operate the equipment.

NOTE

To protect your vehicle from theft, please pay close attention to the following security precautions:

- **Never leave your vehicle unattended with its keys inside.**
- **Before leaving your vehicle, close all windows and lock the doors (all models) and rear gate (Outback).**
- **Do not leave spare keys or any record of your key number in the vehicle.**

CAUTION

- **Do not place the key under direct sunlight or anywhere it may become hot.**

- **Do not get the key wet. If the key gets wet, wipe it dry with a cloth immediately.**

■ Security ID plate



- 1) Key number plate
- 2) Security ID plate

The security ID is stamped on the security ID plate attached to the key set. Write down the security ID and keep it in another safe place, not in the vehicle. This number is needed to make a replacement key if you lose your key or lock it inside the vehicle.

This number is also needed for replacement or repair of the engine control unit, integrated unit, combination meter (all models) and security control unit

(Canada-spec. models).

■ Security indicator light

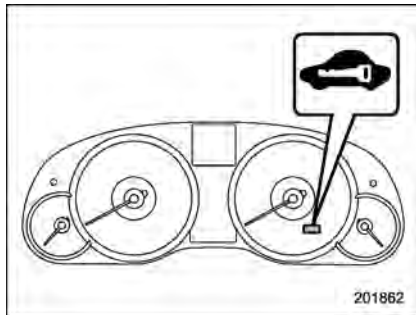

The security indicator light deters potential thieves by indicating that the vehicle is equipped with an immobilizer system. It begins flashing approximately 60 seconds after the ignition switch is turned from the "ON" position to the "Acc" or "LOCK" position or immediately after the key is pulled out.

If the security indicator light does not flash, the immobilizer system may be malfunctioning. If this occurs, contact your SUBARU dealer as soon as possible.

In case an unauthorized key is used (e.g. an imitation key), the security indicator light illuminates.

NOTE

Even if the security indicator light flashes irregularly or its fuse blows (the light does not flash if its fuse is blown), the immobilizer system will function normally.

■ Key replacement

Your key number plate and security ID plate will be required if you ever need a replacement key made. Any new key must be registered for use with your vehicle's immobilizer system before it can be used. Up to four keys can be registered for use with one vehicle.

For security, all the keys registered with your vehicle's immobilizer system will have their ID codes erased and re-registered when a new key is made. Therefore, all of your vehicle's keys must be presented when a new key is registered. Any key that is not re-registered when a new key is made cannot be used after the other keys are re-registered. For information on replacement keys and on the registration of keys with your immobilizer system, contact your SUBARU dealer.

NOTE

A vehicle that is equipped with the remote engine start system as a dealer option can register up to four keys for use with one vehicle.

Door locks

■ Locking and unlocking from the outside

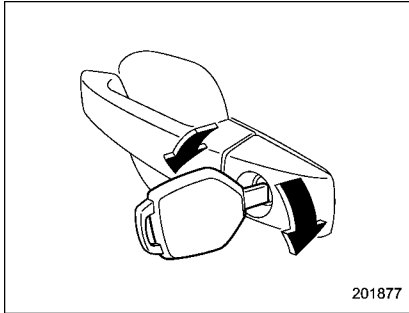

To lock the driver's door from the outside with the key, turn the key toward the rear. To unlock the door, turn the key toward the front.

Lift the outside door handle to open an unlocked door.

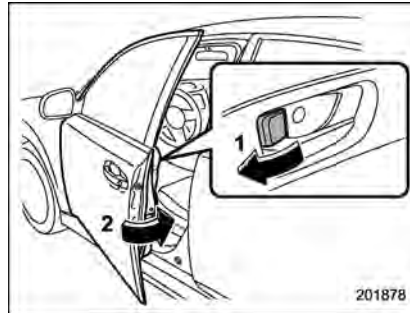

Locking without the key

- 1) Rotate the lock lever rearward.
- 2) Close the door.

To lock the door from the outside without the key, rotate the lock lever rearward and then close the door.

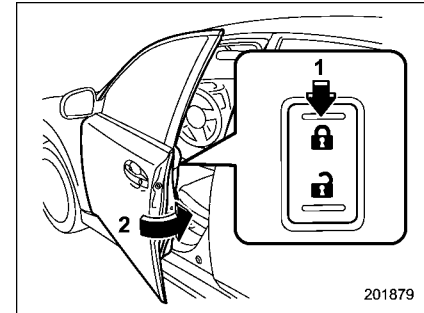

Locking without the key

- 1) Press the front side of the power door locking switch.
- 2) Close the door.

To lock the door from the outside using the power door locking switch, press the front side of the switch ("LOCK" side) and then close the door. In this case, all closed doors and the rear gate (Outback) are locked at the same time.

Always make sure that all doors and the rear gate are locked before leaving your vehicle.

NOTE

Make sure that you do not leave the key inside the vehicle before locking the doors from the outside without the key.

■ Locking and unlocking from the inside

WARNING

Keep all doors locked when you drive, especially when small children are in your vehicle.

Along with the proper use of seatbelts and child restraints, locking the doors reduces the chance of being thrown out of the vehicle in an accident.

It also helps prevent passengers from falling out by preventing a door from being accidentally opened, and intruders from unexpectedly opening doors and entering your vehicle.

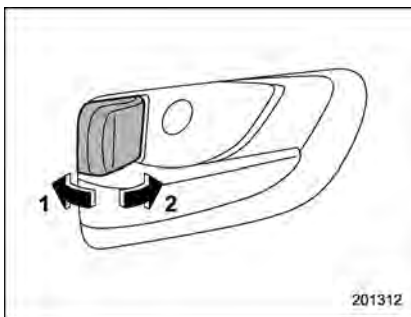

- 1) Lock
- 2) Unlock

To lock the door from the inside, rotate the lock lever rearward. To unlock the door from the inside, rotate the lock lever forward.

The red mark on the lock lever appears when the door is unlocked.

Pull the inside door handle to open an unlocked door.

Always make sure that all doors and the rear gate (Outback) are closed before starting to drive.

■ Battery drainage prevention function

If a door or the rear gate (Outback) is not completely closed, the interior lights will remain illuminated as a result. However, several lights are automatically turned off by the battery drainage prevention function to prevent the battery from going dead. The following interior lights are affected by this function.

| Item | Switch position | Automatically turning off |
|-----------------------|-----------------|--------------------------------|
| Map lights | OFF*1 | Approximately 20 minutes later |
| Dome lights | DOOR | Approximately 20 minutes later |
| Ignition switch light | — | Approximately 20 minutes later |
| Door step lights | — | None*2 |
| Cargo area light | DOOR | Approximately 20 minutes later |

*1: The map lights can be controlled by the battery drainage prevention function only when the map light switches are in the OFF position and the door interlock switch is in the DOOR position. For the switch positions, refer to "Map light" 6-2.

*2: The door step lights are not affected by the battery drainage prevention function, so the

lights do not turn off automatically. To turn off the lights, it is necessary that each door is completely closed.

The operational/non-operational setting of this function can be changed by a SUBARU dealer. Contact the nearest SUBARU dealer if you would like to change the setting.

NOTE

- The factory setting (default setting) for this function is set as “operational”.
- When leaving the vehicle, please make sure that all doors and the rear gate (Outback) are completely closed.
- The battery drainage prevention function does not operate while the key is in the ignition switch.

Power door locking switches

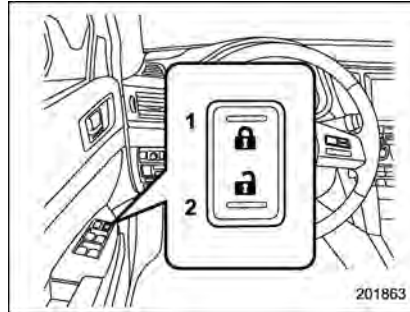

- 1) Lock
- 2) Unlock

All doors and the rear gate (Outback) can be locked and unlocked by the power door locking switches located at the driver's side and the front passenger's side doors.

To lock the doors, press the front side of the switch.

To unlock the doors, press the rear side of the switch.

When you close the doors after you set the door locks, the doors remain locked.

NOTE

Make sure that you do not leave the key inside the vehicle before locking the

doors from the outside using the power door locking switches.

■ Key lock-in prevention function

This function prevents the doors from being locked with the key still in the ignition switch.

▼ Behavior with key lock-in prevention function operational

With the driver's door open, the doors are automatically kept unlocked even if the front side of the power door locking switch is pressed.

▼ Behavior with key lock-in prevention function non-operational

- If the lock lever is turned to the rear (“LOCK”) position with the driver's door open and the driver's door is then closed with the lock lever in that position, the driver's door is locked.
- If the spare key is used to lock the driver's door from the outside of the vehicle, the door is locked.

This function's operational/non-operational setting can be changed by a SUBARU dealer. Contact a SUBARU dealer for details.

NOTE

- The factory setting (default setting) for this function is set as “operational”.
- When leaving the vehicle, make sure you are holding the key before locking the doors.

Remote keyless entry system
 **CAUTION**

- Do not expose the remote transmitter to severe shocks, such as those experienced as a result of dropping or throwing.
- Do not take the remote transmitter apart except when replacing the battery.
- Do not get the remote transmitter wet. If it gets wet, wipe it dry with a cloth immediately.
- When you carry the remote transmitter on an airplane, do not press the button of the remote transmitter while in the airplane. When any button of the remote transmitter is pressed, radio waves are sent and may affect the operation of the airplane. When you carry the remote transmitter in a bag on an airplane, take measures to prevent the buttons of the remote transmitter from being pressed.

This device complies with Part 15 of the FCC Rules and with RSS-210 of Industry Canada. Operation is subject

to the following two conditions: (1) This device may not cause harmful interference, and (2) this device must accept any interference received, including interference that may cause undesired operation.

Changes or modifications not expressly approved by the party responsible for compliance could void the user's authority to operate the equipment.

The transmitter for the remote keyless entry system is located inside the key head.

The remote keyless entry system has the following functions.

- Locking and unlocking the doors (and rear gate (Outback)) without a key
- Opening the trunk lid (Legacy) without key
- Sounding a panic alarm
- Arming and disarming the alarm system. For detailed information, refer to “Alarm system” ¶2-16.



The operable distance of the remote keyless entry system is approximately 30 feet (10 meters). However, this distance will vary depending on environmental conditions. The system's operable distance will be shorter in areas near a

facility or electronic equipment emitting strong radio waves such as a power plant, broadcast station, TV tower, or remote controller of home electronic appliances.

NOTE

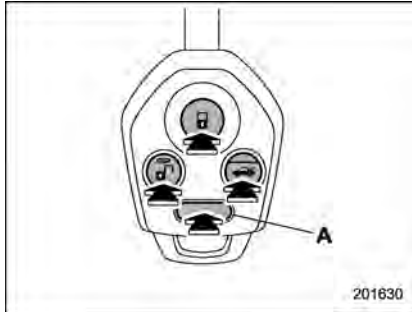
The remote keyless entry system does not operate when the key is inserted in the ignition switch.



-  : Trunk lid/rear gate unlock button
-  : Unlock/disarm button
-  : Lock/arm button
- A: Panic button

■ Locking the doors

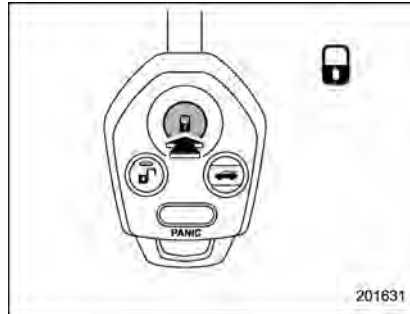



Press the “” button to lock all doors and rear gate (Outback). An electronic chirp will sound once and the turn signal lights will flash once.

If any of the doors (or the rear gate/trunk lid) is not fully closed, an electronic chirp will sound five times and the turn signal lights will flash five times to alert you that the doors (or the rear gate/trunk lid) are not properly closed. When you close the door, it will automatically lock and then an electronic chirp will sound once and the turn signal lights will flash once.

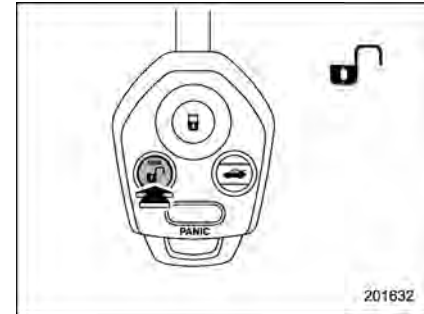
■ Unlocking the doors





Press the “” button to unlock the driver's door. An electronic chirp will sound twice and the turn signal lights will flash twice. To unlock all doors and the rear gate (Outback), briefly press the “” button a second time within 5 seconds.

NOTE

If the interval between the first and second presses of the “” button (for unlocking of all of the doors and the rear gate) is extremely short, the system may not respond.

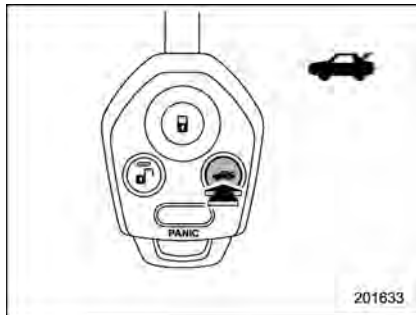
■ Opening the trunk lid (Legacy)



The trunk lid opens when the “” button is pressed continuously for at least 2 seconds. An electronic chirp will sound twice and the turn signal lights will flash twice.

■ Unlocking the rear gate (Outback)

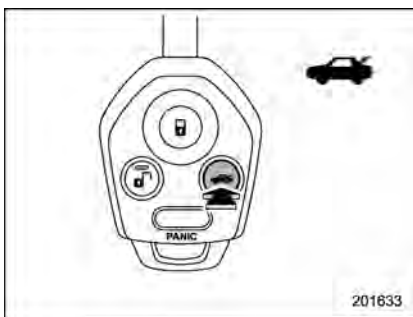

Pressing the “” button unlocks the rear gate.

An electronic chirp will sound twice and the turn signal lights will flash twice.

■ Vehicle finder function

Use this function to find your vehicle parked among many vehicles in a large parking lot. Provided you are within 30 feet (10 meters) of the vehicle, pressing the “” button three times in a 5-second period will cause your vehicle’s horn to sound once and its turn signal lights to flash three times.

NOTE

If the interval between presses is too short when you press the “” button three times, the system may not respond to the signals from the remote transmitter.

■ Sounding a panic alarm



To activate the alarm, press the “PANIC” button once.

The horn will sound and the turn signal lights will flash.

To deactivate the panic alarm, press any button on the remote transmitter. If a button on the remote transmitter is not pressed, the alarm will be deactivated after approximately 30 seconds.

■ Selecting audible signal operation

Using an electronic chirp, the system will give you an audible signal when the doors lock and unlock. If desired, you may turn the audible signal off.

To deactivate the audible signal, perform the following procedure. You can also use the same steps to restore the function.

1. Sit in the driver's seat and shut all doors and the rear gate.
2. Press the "UNLOCK" side of the power door locking switch.
3. Insert the key into the ignition switch.
4. While holding down the "UNLOCK" side of the power door locking switch, pull the key out and re-insert it into the ignition switch at least 5 times within 10 seconds after performing step 2.
5. Open and close the driver's door within 10 seconds after performing step 4.
6. To indicate completion of the setting, the turn signal lights flash 3 times and the chirp sounds 3 times.

You may have the above procedure preformed by your SUBARU dealer.

■ Replacing the battery



CAUTION

- Do not let dust, oil or water get on or in the transmitter when replacing the battery.
- Be careful not to damage the printed circuit board in the transmitter when replacing the battery.
- Be careful not to allow children to touch the battery and any removed parts; children could swallow them.
- There is a danger of explosion if an incorrect replacement battery is used. Replace only with the same or equivalent type of battery.
- Batteries should not be exposed to excessive heat such as sunshine, fire or the like.

If the transmitter fails to operate when used within the standard distance, this may indicate a weak battery. Replace the battery as soon as possible. The battery can be replaced by your authorized SUBARU dealer. If you replace the battery by yourself, use utmost care that no dust, oil or water enters the transmitter.

To replace the battery:

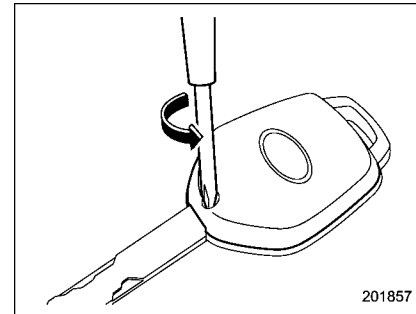

1. Remove the screw on the key head.

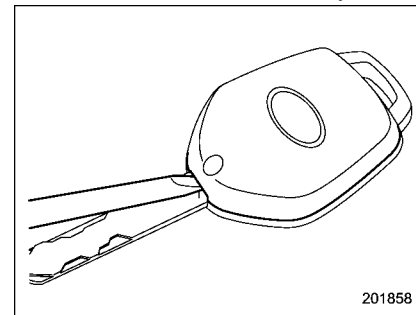

2. Open the key head using a flat-head screwdriver.

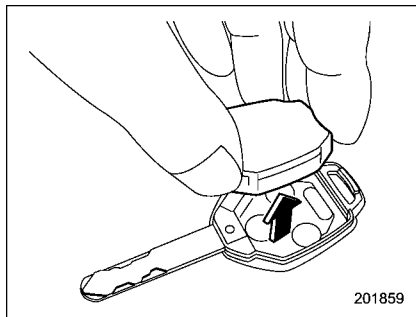

3. Remove the transmitter case from the key head.

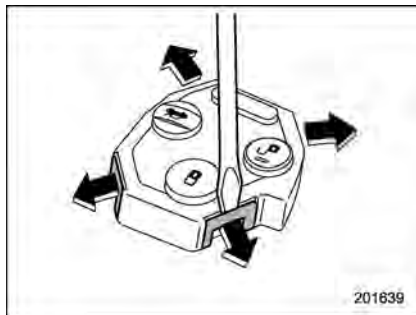

4. Open the transmitter case by releasing the hooks.

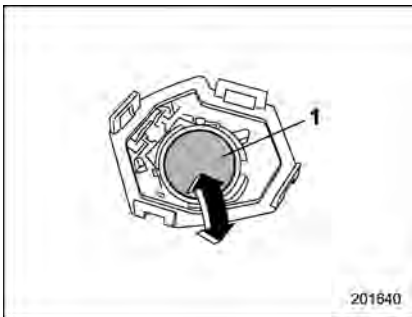

1) Negative (-) side facing up

5. Replace the old battery with a new battery (Type CR1620 or equivalent) making sure to install the new battery with the negative (-) side facing up.

6. Put together the transmitter case by fitting the hooks on the case.

7. Reinstall the transmitter case in the key head.

8. Reinstall the screw on the key head.

After the battery is replaced, the transmitter must be synchronized with the remote keyless entry system's control unit. Press either the "⏏" or "⏏" button six times to synchronize the unit.

■ Replacing lost transmitters

If you lose a transmitter or want to purchase additional transmitters (up to four can be programmed), you should re-program all of your transmitters for security reasons. It is recommended that you have your dealer program all of your transmitters into your system.

▼ Programming the transmitters

The remote keyless entry system is equipped with a special code learning feature that allows you to program new transmitter codes into the system or to delete old ones. The system can learn up to four unique transmitter codes. The four transmitter codes may be the same or different.

Programming transmitter codes into system:

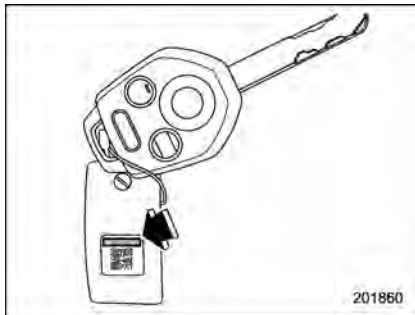

Key unit tag

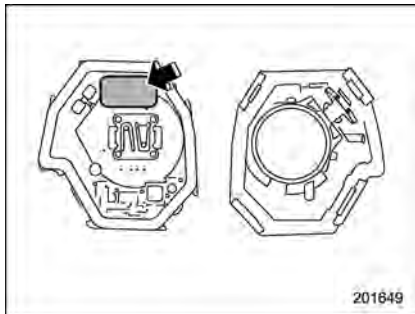

Transmitter circuit board

To register a new transmitter with the remote keyless entry system, it is neces-

sary to program the transmitter's code (identification number) into the system. A tag showing the code is affixed to the key unit, and another is affixed to the circuit board inside the transmitter. If there is no tag, open the transmitter case and make a note of the eight-digit number. Program the number into the system in accordance with the following procedure.

1. Firmly close the doors and the rear gate (Outback) or trunk lid (Legacy).
2. Open the driver's door, sit in the driver's seat, and close the door.
3. Perform the following steps within 45 seconds.

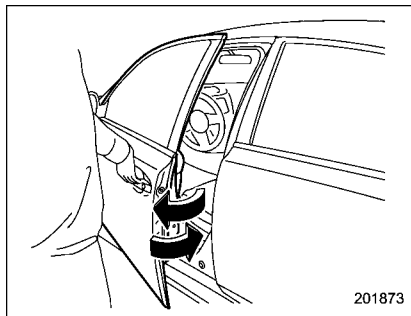

- (1) Open and close the driver's door once.

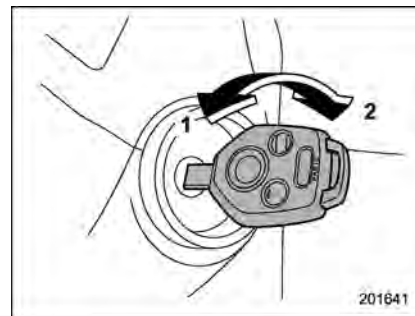

- 1) LOCK
- 2) ON

(2) Insert the key into the ignition switch, then turn it from the "LOCK" position to the "ON" position 10 times within 15 seconds.

NOTE

- When you complete step (2), an electronic tone will sound once.
- If you do not perform steps (1) and (2) within 45 seconds, an error will occur. An electronic tone will not sound. In this event, perform the whole procedure again beginning with part 1.

4. Open and close the door once within 15 seconds.

NOTE

- When part 4 of the procedure is completed, an electronic tone will sound for 30 seconds.
- If you do not perform the operations in part 4 within 15 seconds, an error will occur and the electronic tone will not sound. In this event, perform the registration steps again beginning with part 3 of the procedure.

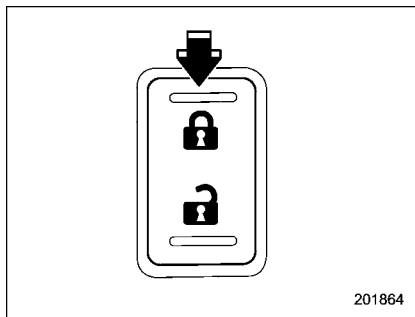

5. Before the electronic tone stops sounding, press the lock side of the power door lock switch the same number of times as the leftmost digit of the transmitter code. For example, press the lock switch eight times if the leftmost digit of the code is 8.

NOTE

- The electronic tone will stop sounding when you start entering the number.
- If you do not start entering the number using the lock switch before the electronic tone stops sounding, an error will occur. In this event, perform the registration steps again beginning with part 3 of the procedure.
- If the interval between one press of the switch and the next exceeds 5 seconds, an error will occur. In this event, perform the procedure again beginning with part 4. If an error occurs six times, perform the procedure again starting with part 3.

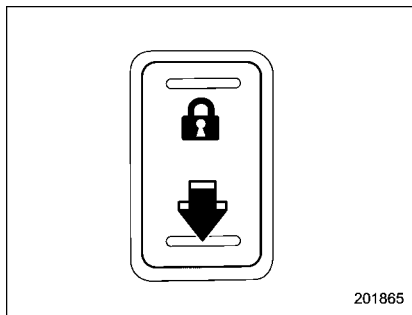

6. When you have finished entering the number, press the unlock side of the lock

switch within 5 seconds.

NOTE

- An electronic tone will sound.
- If you press the unlock side of the lock switch when more than 5 seconds have passed, an error will occur. In this event, perform the procedure again beginning with part 4. If an error occurs six times, perform the procedure again starting with part 3.

7. Perform parts 5 and 6 of the procedure for each of the remaining digits of the transmitter code beginning with the second digit (counting from the left) and finishing with the eighth digit.

NOTE

- When you finish entering the eighth digit, an electronic tone will sound for 30 seconds.
- If the interval between one press of the switch and the next exceeds 5 seconds, an error will occur. In this event, perform the procedure again beginning with part 4. If an error occurs six times, perform the procedure again starting with part 3.

8. Before the electronic tone stops sounding, use the power door lock switch to reenter the transmitter code beginning with the leftmost digit.

NOTE

If you do not start entering the number using the lock switch before the electronic tone stops sounding, an error will occur. In this event, perform the procedure again beginning with part 3.

9. When you have finished entering the code a second time, an electronic tone will sound for 1 second to indicate completion of registration, provided the code entered the second time is identical to that entered the first time.

NOTE

If the code entered the second time is not identical to the code entered the first time, an error will occur. In this event, perform the procedure again beginning with part 5. If an error occurs five times, perform the procedure again starting with part 3.

10. If you wish to program another transmitter code into the system (up to four transmitter codes can be programmed into the system), perform the procedure beginning with part 4. When you have finished programming all of the necessary transmitter codes into the system, remove the key from the ignition switch.

11. Test every registered transmitter to confirm correct operation.

▼ Deleting old transmitter codes

The control unit of the remote keyless entry system has four memory locations to store transmitter codes, giving it the ability to operate with up to four transmitters. When you lose a transmitter, the lost transmitter's code remains in the memory. For security reasons, lost transmitter codes should be deleted from the memory.

To delete old transmitter codes, program four transmitter codes into the system. If you have only one current transmitter, program it four times. If you have two current transmitters, program each one twice. If you have three current transmitters, program two of them once and the third one twice. This process will leave only current transmitter codes in the system's memory.

NOTE

Make sure no one else is operating their remote keyless entry system within range of your vehicle when programming transmitters. If someone else were to operate their remote transmitter while you are programming your transmitters, it is possible that their transmitter code will be programmed into your system, allowing them unauthorized access to your vehicle.

Alarm system

The alarm system helps to protect your vehicle and valuables from theft. The horn sounds and the turn signal lights flash if someone attempts to break into your vehicle.

The system can be armed and disarmed with the remote transmitter.

The system does not operate when the key is inserted into the ignition switch.

Your vehicle's alarm system has been set for activation at the time of shipment from the factory. You can set the system for deactivation yourself or have it done by your SUBARU dealer.

■ System alarm operation

The alarm system will give the following alarms when triggered:

- The vehicle's horn will sound and the turn signal lights will flash for 30 seconds.
- If any door (or the rear gate/trunk lid) remains open after the 30-second period, the horn will continue to sound for a maximum of 3 minutes. If the door (or the rear gate/trunk lid) is closed while the horn is sounding, the horn will stop sounding with a delay of up to 30 seconds.

The alarm is triggered by:

- Opening a door, the rear gate or trunk lid
- Physical impact to the vehicle, such as forced entry (only models with shock sensors (dealer option))

NOTE

The alarm system can be set to trigger illumination of map lights and dome light. The map lights and dome light notification is deactivated as the factory setting. Refer to "Function settings" 2-20. A SUBARU dealer can activate the system. Contact your SUBARU dealer for details.

■ Activating and deactivating the alarm system

To change the setting of your vehicle's alarm system for activation or deactivation, do the following.

1. Disarm the alarm system. Refer to "Disarming the system" 2-18.
2. Sit in the driver's seat and shut all doors (and the rear gate (Outback)).
3. Turn the ignition switch to the "ON" position.
4. Hold down the REAR (UNLOCK) side of the driver's power door locking switch, open the driver's door within the following

1 second, and wait 10 seconds without releasing the switch. The setting will then be changed as follows:

If the system was previously activated:

The trip meter screen displays "AL oF" and the horn sounds twice, indicating that the system is now deactivated.

If the system was previously deactivated:

The trip meter screen displays "AL on" and the horn sounds once, indicating that the system is now activated.

NOTE

You may have the above setting change done by your SUBARU dealer.

■ If you have accidentally triggered the alarm system

▼ To stop the alarm

Perform any of the following operations.



- Press any button on the remote transmitter.
- Turn the ignition switch to the "ON" position.

■ Arming the system

▼ To arm the system using remote transmitter

1. Close all windows and the moonroof (if equipped).
2. Remove the key from the ignition switch.
3. Open the doors and get out of the vehicle.
4. Make sure that the engine hood (and the trunk lid (Legacy)) are locked.
5. Close all doors (and the rear gate (Outback)).



-  : Press to Arm the system.
 : Press to Disarm the system.

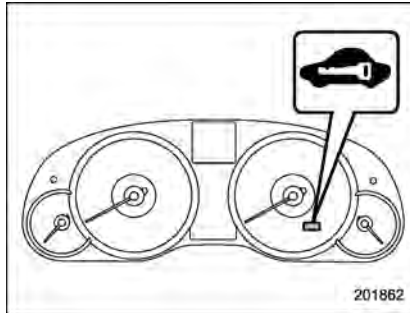

6. Briefly press the “” button (for less than 2 seconds). All doors (and the rear gate (Outback)) will lock, an electronic chirp will sound once, the turn signal lights will flash once, and the security indicator light will start flashing rapidly. After rapid flashing for 30 seconds (standby time), the security indicator light will then flash slowly (twice approximately every 2 seconds), indicating that the system has been armed for surveillance.

If any of the doors (rear gate or trunk lid) is not fully closed, an electronic chirp sounds five times, the turn signal lights flash five times to alert you that the doors (or the rear gate) are not properly closed. When you close the door, the system will automatically arm and doors will automatically lock.

▼ To arm the system using power door locking switch

1. Close all windows.
2. Remove the key from the ignition switch.
3. Open the doors and get out of the vehicle.
4. Make sure that the engine hood is locked.
5. Close the doors (and the rear gate (Outback)) but leave only the driver's door or the front passenger's door open.

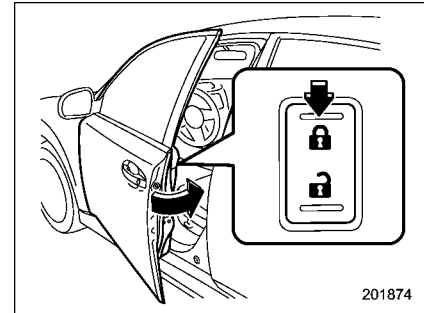

6. Press the front side (“LOCK” side) of the power door locking switch to set the door locks.
7. Close the door. An electronic chirp will sound once, the turn signal lights will flash once and the security indicator light will

start flashing rapidly. After rapid flashing for 30 seconds (standby time), the security indicator light will then flash slowly (twice approximately every 2 seconds), indicating that the system has been armed for surveillance.

NOTE

- The system can be armed even if the engine hood, the windows and/or moonroof are open. Always make sure that they are fully closed before arming the system.
- The 30-second standby time can be eliminated if you prefer. Have it performed by your SUBARU dealer.
- If your vehicle is a Legacy and you open the trunk using the remote transmitter's "" button with the alarm system armed, the system will be temporarily placed in a standby state. The system will go back to the surveillance state upon locking the trunk.
- The system is in the standby mode for a 30-second period after locking the doors with the remote transmitter. The security indicator light will flash at short intervals during this period.
- If any of the following actions is done during the standby period, the system will not switch to the surveillance state.

- Doors are unlocked using the remote transmitter.
- Any door (including the rear gate (Outback) or the trunk (Legacy)) is opened.
- Ignition switch is turned to the "ON" position.

■ Disarming the system

Briefly press the "" button (for less than 2 seconds) on the remote transmitter. The driver's door will unlock, an electronic chirp will sound twice, the turn signal lights will flash twice and the security indicator light will turn off.

To unlock all other doors and the rear gate (Outback), briefly press the "" button a second time within 5 seconds.

▼ Emergency disarming

If you cannot disarm the system using the transmitter (i.e. the transmitter is lost, broken or the transmitter battery is too weak), you can disarm the system without using the transmitter.

The system can be disarmed if you turn the ignition switch from the "LOCK" to the "ON" position with a registered key.

■ Valet mode

When you choose the valet mode, the alarm system does not operate. In valet mode, the remote transmitter is used only for locking and unlocking the doors and rear gate (Outback) and panic activation.

To enter the valet mode, change the setting of your vehicle's alarm system for deactivation mode. Refer to "Activating and deactivating the alarm system" [☞2-16](#). The security indicator light will continue to flash once every 3 seconds indicating that the system is in the valet mode.

To exit valet mode, change the setting of your vehicle's alarm system for activation mode. Refer to "Activating and deactivating the alarm system" [☞2-16](#).

■ Passive arming

When passive arming mode has been programmed by the dealer, arming of the system is automatically accomplished without using the remote transmitter. Note that in this mode, DOORS MUST BE MANUALLY LOCKED.

▼ To enter the passive mode

If you wish to program the passive arming mode, have it done by your SUBARU dealer.

▼ Arming the system

CAUTION

In passive mode, the system will automatically activate the alarm but **WILL NOT** automatically lock the doors. In order to lock the doors you must either lock them as indicated in step 4 below or with the key once they have been closed. Failure to lock the doors manually will result in a higher security risk.

1. Turn the ignition switch to the "ON" position.

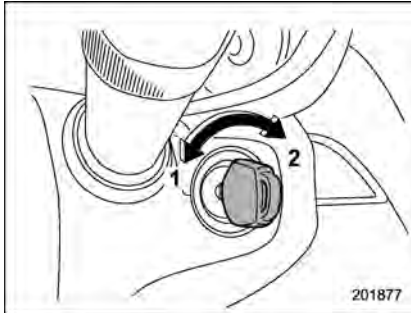

- 1) LOCK
- 2) ON

2. Turn the ignition switch from "ON" to

"LOCK" position and remove the key from the ignition switch.

3. Open the doors and get out of the vehicle.

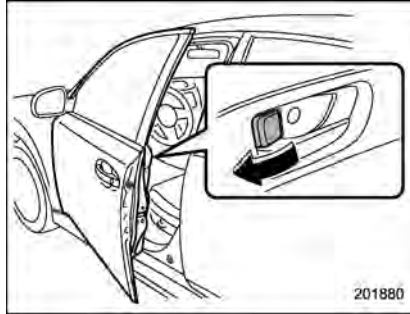

4. Before closing the doors, lock all doors with the inside door lock levers.
5. Close the doors. The system will automatically arm after 1 minute.

In the passive mode, the system can also be armed with the remote transmitter or with the power door locking switches. If the remote transmitter or power door locking switch is used to lock the vehicle, arming will take place immediately regardless of whether or not the passive mode has been selected.

▼ Disarming the system

To disarm the system, briefly press the "⏏" button on the transmitter.

■ Tripped sensor identification

The security indicator light flashes when the alarm system has been triggered. Also, the number of flashes indicates the location of unauthorized intrusion or the severity of impact on the vehicle.

When the ignition switch is turned to the "ON" position, the indicator light will illuminate for 1 second and then flash as follows:

- When a door or rear gate (Outback) was opened: 5 times
- When the trunk (Legacy) was opened: 4 times
- When a strong impact or multiple impacts were sensed: twice (only models with shock sensors (dealer option))
- When a light impact was sensed: once (only models with shock sensors (dealer option))

■ Shock sensors (dealer option)

The shock sensors trigger the alarm system when they sense impacts applied to the vehicle and when any of their electric wires is cut. The alarm system

causes the horn to sound and the turn signal lights to flash for a short time when the sensed impact is weak, but it warns of a strong impact or multiple impacts by sounding the horn and flashing the turn signal lights, both lasting approximately 30 seconds.

If you desire, your SUBARU dealer can connect them and set them for activation or deactivation.

NOTE

- The shock sensors are not always able to sense impacts caused by breaking in, and cannot sense an impact that does not cause vibration (such as breaking the glass using a rescue hammer).
- The shock sensors may sense vibration like those shown in the following and trigger the alarm system. Select the settings of the alarm system and shock sensors appropriately depending on where you usually park your vehicle.

Examples:

- Vibration from construction site
- Vibration in multistory car park
- Vibration from trains
- You can have the sensitivity of the shock sensors adjusted to your preference by your SUBARU dealer.

Child safety locks

WARNING

Always turn the child safety locks to the “LOCK” position when children sit on the rear seat. Serious injury could result if a child accidentally opens the door and falls out.

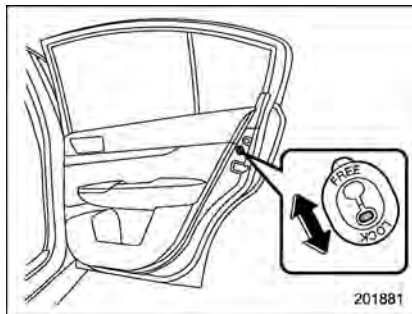

Each rear door has a child safety lock that prevents the doors from being opened even if the inside door handle is pulled.

When the child safety lock lever is in the “LOCK” position, the door cannot be opened from inside regardless of the position of the inner door handle lock lever. The door can only be opened from

the outside.

Windows

WARNING

To avoid serious personal injury caused by entrapment, always conform to the following instructions without exception.

- When operating the power windows, be extremely careful to prevent anyone's fingers, arms, neck, head or other objects from being caught in the window.
- Always lock the passengers' windows using the lock switch when children are riding in the vehicle.
- Before leaving the vehicle, always remove the key from the ignition switch for safety and never allow an unattended child to remain in the vehicle. Failure to follow this procedure could result in injury to a child operating the power window.

The power windows operate only when the ignition switch is in the "ON" position.

■ Power window operation by driver

▼ Driver's side power window switches

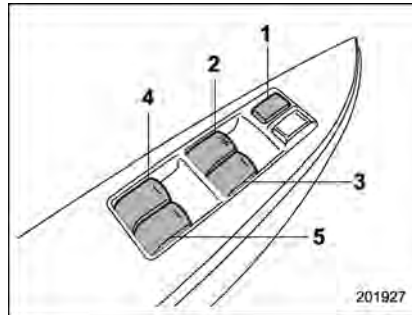

- 1) Lock switch
- 2) For driver's window
- 3) For front passenger's window
- 4) For rear left passenger's window
- 5) For rear right passenger's window

All door windows can be controlled by the power window switch cluster at the driver side door.

▼ Operating the driver's window

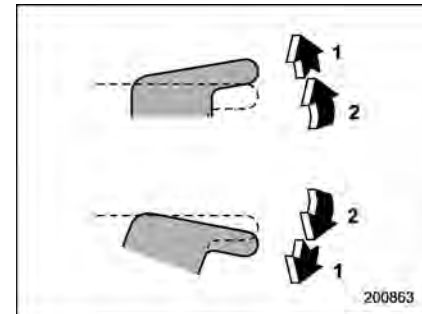

- 1) Automatically open/close
- 2) Open/close

To open:

Press the switch down lightly and hold it. The window will open as long as the switch is held.

This switch also has a one-touch auto down function that allows the window to be opened fully without holding the switch. Press the switch down until it clicks and release it, and the window will fully open. To stop the window halfway, pull the switch up lightly.

To close:

Pull the switch up lightly and hold it. The window will close as long as the switch is

held.

For some models, this switch also has a one-touch auto up function that allows the window to be closed fully without holding the switch.

Pull the switch up until it clicks and release it, and the window will fully close. To stop the window halfway, press the switch down lightly.

NOTE

If the vehicle's battery is disconnected due to situations such as battery or fuse replacement, the one-touch auto up/down function is deactivated. Initialize the power window to reactivate the one-touch auto up/down function. Refer to "Initialization of power window" 2-24.

▼ Anti-entrapment function



CAUTION

- Never attempt to test this function using fingers, hands or other parts of your body.
- The anti-entrapment function may not operate properly if some object gets trapped just before the window fully closes.

NOTE

- If a window detects an impact similar to that caused by trapping an object depending on the driving conditions, the anti-entrapment function may operate.
- The window cannot be operated for a few seconds after the anti-entrapment function operates.
- If the vehicle's battery is disconnected due to situations such as battery or fuse replacement, the anti-entrapment function is deactivated. Initialize the power window to reactivate the anti-entrapment function. Refer to "Initialization of power window" 2-24.

While closing automatically, if the window senses a substantial enough object trapped between the window and the window frame, it automatically moves down slightly and stops.

▼ Operating the passengers' windows

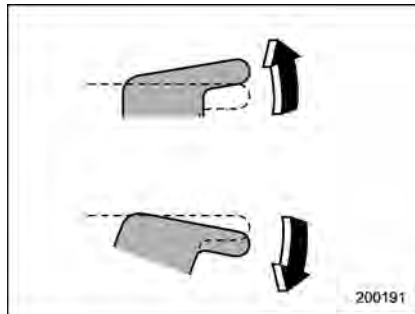

To open:

Press the appropriate switch down and hold it until the window reaches the desired position.

To close:

Pull the switch up and hold it until the window reaches the desired position.

▼ Locking the passengers' windows

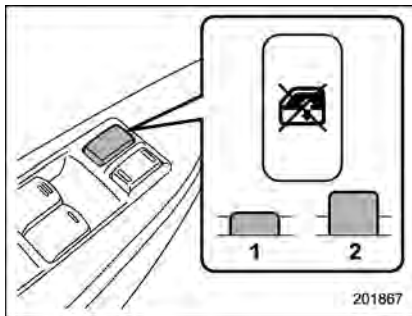

- 1) Lock
- 2) Unlock

To lock:

Press the lock switch. When the lock switch is in the pressed "LOCK" position, the passengers' windows cannot be opened or closed.

To unlock:

Press the lock switch again.

■ Power window operation by passengers

▼ Passenger's side power window switches

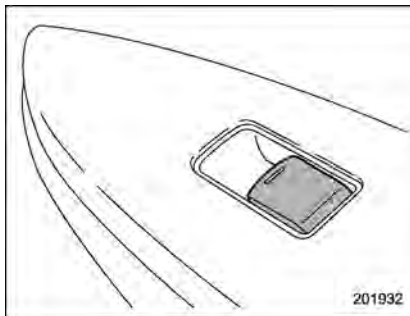

Each passenger window can be controlled by the power window switch located on the door.

▼ Operating the windows

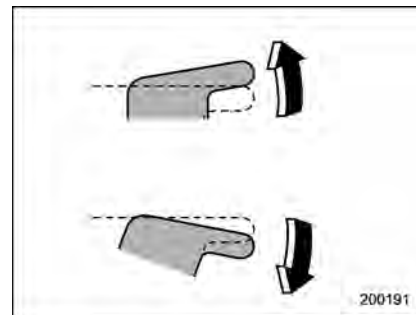

To open:

Press the switch down and hold it until the window reaches the desired position.

To close:

Pull the switch up and hold it until the window reaches the desired position.

When the lock switch on the power window switch cluster, located on the driver's side door, is in the "LOCK" position, the passengers' windows cannot be operated with the passengers' switches.

■ Initialization of power window

If the vehicle's battery is disconnected due to situations such as battery or fuse replacement, the following functions are deactivated.

- One-touch auto up/down function
- Anti-entrapment function

Initialize the power window in the following procedure to reactivate such functions.

1. Close the driver's door.
2. Turn the ignition switch to the "ON" position.
3. Open the driver's side window halfway by pushing down the power window switch.
4. Pull up the power window switch and close the window completely. Continue pulling up the switch for approximately 1 second after the window is closed completely.

Trunk lid (Legacy)

⚠ WARNING

- To prevent dangerous exhaust gas from entering the vehicle, always keep the trunk lid closed while driving.
- Help prevent children, adults or animals from locking themselves in the trunk. On hot or sunny days, the temperature in the trunk could quickly become high enough to cause death or serious heat-related injuries including brain damage to anyone locked inside, particularly for small children.
- When leaving the vehicle, close all windows and lock all doors. Also make certain that the trunk is closed.

■ To open and close the trunk lid from outside

The trunk lid can be opened using the remote keyless entry system. Refer to "Unlocking the rear gate (Outback)" 2-10.

To close the trunk lid, lightly press the trunk lid down until the latch engages.

NOTE

- Do not leave your valuables in the trunk when you leave your vehicle.
- Even when the trunk lid cannot be opened using the remote keyless entry system, you can open the trunk lid by using the key. Refer to "Trunk lid (Legacy) – if the trunk lid cannot be opened" 9-19.

■ To open the trunk lid from inside

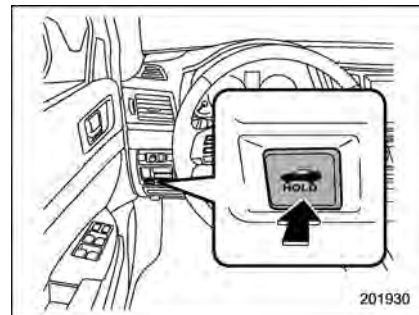

Press the trunk lid opener switch for more than 1 second.

▼ To lock and unlock the trunk lid opener switch

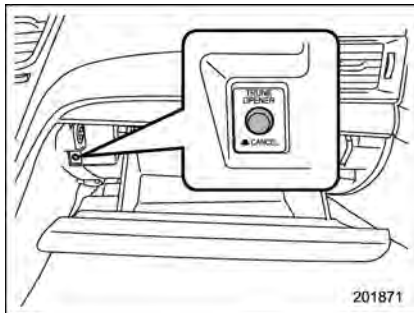

When you entrust your vehicle key to another person, you can lock the trunk lid opener switch to prevent items in the trunk from being stolen.

To lock the trunk lid opener switch, perform the following procedure.

1. Open the glove box. Refer to "Glove box" 6-6.
2. Press the trunk lid opener lock button.

To unlock the trunk lid opener switch, perform the same procedure again.

■ Internal trunk lid release handle

The internal trunk lid release handle is a device designed to open the trunk lid from inside the trunk. In the event children or adults become locked inside the trunk, the handle allows them to open the lid. The handle is located on the inside of the trunk lid.

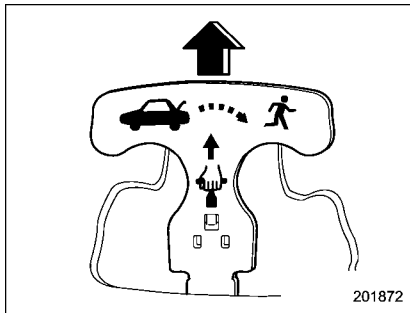

To open the trunk lid from inside the trunk, pull the yellow handle as indicated by the arrow on the handle. This operation unlocks the trunk lid. Then, push up the lid.

The handle is made of material that remains luminescent for approximately an hour in the dark trunk space after it is exposed to ambient light even for a short time.

WARNING

Never allow any child to get in the trunk and play with the release handle. If the driver starts the vehicle without knowing that a child is inside the trunk and the child opens the lid using the release handle, the child could fall out and be killed or seriously injured.

CAUTION

- Do not close the lid while gripping the release handle. The handle may be damaged.
- Do not use the handle as a hook to fasten straps or ropes to secure your cargo in the trunk. Such use may result in damage of the handle.
- Load the trunk so that cargo can not strike the release handle. If the cargo hits the handle while the vehicle is being driven, the handle may be pulled and the trunk lid may open. That may cause cargo to fall out of the trunk, which could create a traffic safety hazard.

▼ **Inspection**

Perform the following steps at least twice a year to check the release handle for correct operation.

1. Open the trunk lid.

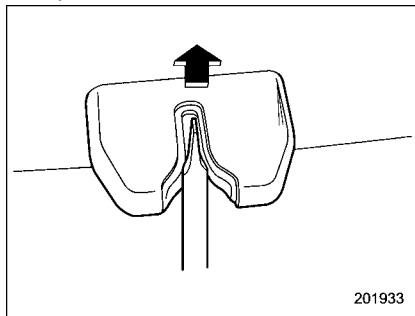

2. Use a flat-head screwdriver with a thin blade. Slide the flat-head screwdriver blade from the slit aperture of the lock assembly fully to the end until you hear a click.

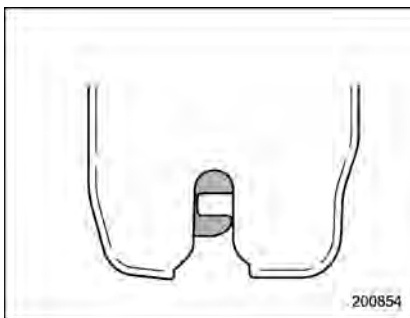

This places the latch in the locked position.

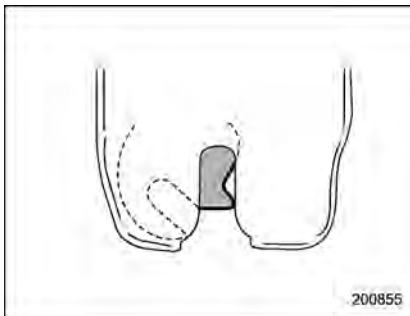

3. Move the release handle, from outside the vehicle, in the direction of the arrow to check if the latch is released.

If the latch is not released, contact your SUBARU dealer.

In that case, use the key to release the latch, then close the trunk lid.

Also, if the movement of the release handle feels restricted or not entirely smooth during operation, or the handle and/or handle base is cracked, contact your SUBARU dealer.

Rear gate (Outback)

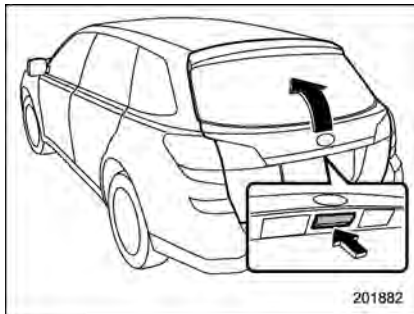

The rear gate can be locked and unlocked using any of the following systems.

- Power door locking switch: Refer to "Power door locking switches" 2-7.
- Remote keyless entry system: Refer to "Remote keyless entry system" 2-8.

To open:

First unlock the rear gate lock then push the rear gate opener button.

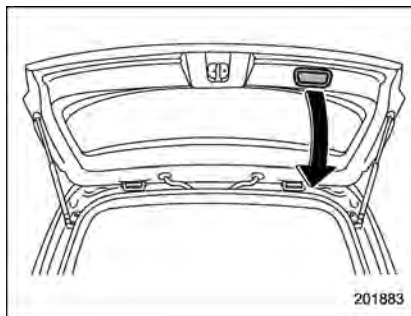

To close:

Lower the rear gate slowly and push down firmly until the latch engages.

The rear gate can be lowered easily if you pull it down holding the recessed grip.

WARNING

- To prevent dangerous exhaust gas from entering the vehicle, always keep the rear gate closed while driving.
- Do not attempt to shut the rear gate while holding the recessed grip. Also avoid closing the rear gate by pulling on the recessed grip from inside the cargo space. There is a danger of your hand being caught and injured.

CAUTION

- Do not jam a plastic bag in or place cellophane tape on the rear gate stays or scratch the stays while loading or unloading cargo. That could cause leakage of gas from the stays, which may result in their inability to hold the rear gate open.
- Be careful not to hit your head or face on the rear gate when opening or closing the rear gate and when loading or unloading cargo.

NOTE

If the rear gate cannot be unlocked due to a discharged vehicle battery, a malfunction in the door locking/unlocking system or other causes, you can unlock it by manually operating the rear gate lock release lever. For the procedure, refer to “Rear gate (Out-back) – if the rear gate cannot be unlocked” 9-19.

Moonroof (if equipped)**WARNING**

Never let anyone’s hands, arms, head or any objects protrude from the moonroof. A person could be seriously injured if the vehicle stops suddenly or turns sharply or if the vehicle is involved in an accident.

To avoid serious personal injury caused by entrapment, you must conform to the following instructions without exception.

- Before closing the moonroof, make sure that no one’s hands, arms, head or other objects will be accidentally caught in the moonroof.
- Before leaving the vehicle, always remove the key from the ignition switch for safety and never allow an unattended child to remain in the vehicle. Failure to follow this procedure could result in injury to a child operating the moonroof.

**CAUTION**

- Never try to check the anti-entrapment function by deliberately placing part of your body in the moonroof.

- Do not sit on the edge of the open moonroof.
- Do not operate the moonroof if falling snow or extremely cold conditions have caused it to freeze shut.
- The anti-entrapment function does not operate when the moonroof is being tilted down. Be sure to confirm that it is safe to do so before tilting the moonroof down.

The moonroof has both tilting and sliding functions.

The moonroof operates only when the ignition switch is in the “ON” position.

■ Moonroof switches

▼ Tilting moonroof

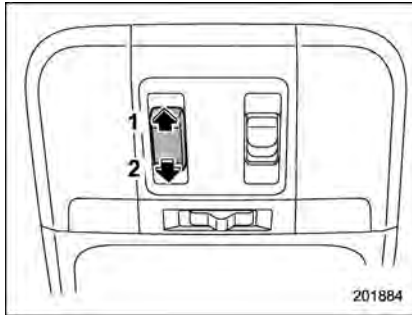

- 1) Raise
- 2) Lower

The raising function will only operate when the moonroof is fully closed. The lowering function will only operate when the moonroof is raised.

Press the rear side of the “UP/DOWN” switch to raise the moonroof.

Press the front side of the “UP/DOWN” switch to lower the moonroof.

Release the switch after the moonroof has been raised or has been lowered completely. Pressing the switch continuously may cause damage to the moonroof.

NOTE

One-touch operation does not take place when the moonroof is lowered. Press the switch continuously to lower the moonroof.

▼ Sliding moonroof

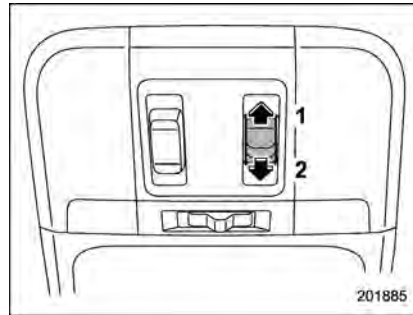

- 1) Open
- 2) Close

Press the “OPEN/CLOSE” switch rearward to open the moonroof. The sun shade will also be opened together with the moonroof. For Outback, the moonroof will stop at a position 11 in (29 cm) away from the fully closed position. Press the switch again to open the moonroof completely.

Press the “OPEN/CLOSE” switch forward to close the moonroof.

To stop the moonroof at a selected mid-way position while opening or closing it, momentarily press the switch to the “OPEN” side or “CLOSE” side.

After washing the vehicle or after it rains, wipe away water on the roof prior to opening the moonroof to prevent drops of water from falling into the passenger compartment.

NOTE

- For the sake of safety, it is recommended that you avoid driving with the moonroof fully opened.
- If the moonroof cannot be closed through the switch operation because of system failure, it can be closed manually using a hex-head wrench. For the procedure, refer to “Moonroof – if moonroof cannot be closed” 9-20.

▼ Anti-entrapment function

When the moonroof senses a substantial enough object trapped between its glass and the vehicle’s roof during closure, it automatically moves back to the fully open position and stops there. The anti-entrapment function may also be activated by a strong shock on the moonroof even when there is nothing trapped.

 **CAUTION**

Never attempt to test this function using fingers, hands or other parts of your body.

■ **Sun shade**

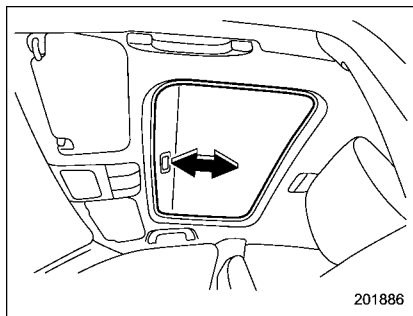

The sun shade can be slid forward or backward by hand while the moonroof is closed.

If the moonroof is opened, the sun shade also moves back.

| | | | |
|---|------|--|------|
| Ignition switch | 3-3 | AT OIL TEMP warning light (AT and CVT models) | 3-15 |
| LOCK | 3-3 | Low tire pressure warning light (U.S.-spec. models)..... | 3-15 |
| Acc | 3-4 | ABS warning light | 3-16 |
| ON | 3-4 | Brake system warning light | 3-17 |
| START | 3-4 | Hill Holder indicator light | 3-19 |
| Key reminder chime | 3-4 | Low fuel warning light | 3-19 |
| Ignition switch light | 3-4 | Door open warning light | 3-20 |
| Hazard warning flasher | 3-5 | Door open indicator light | 3-20 |
| Meters and gauges | 3-5 | Windshield washer fluid warning light | 3-20 |
| Combination meter illumination | 3-5 | All-Wheel Drive warning light (AT and CVT models) | 3-20 |
| Canceling the function for meter/gauge needle movement upon turning on the ignition switch | 3-5 | Vehicle Dynamics Control warning light/Vehicle Dynamics Control operation indicator light | 3-20 |
| Speedometer | 3-6 | Vehicle Dynamics Control OFF indicator light | 3-21 |
| Odometer | 3-6 | Security indicator light | 3-22 |
| Double trip meter | 3-6 | Select lever/gear position indicator | 3-22 |
| Tachometer | 3-7 | Turn signal indicator lights | 3-23 |
| Fuel gauge | 3-7 | High beam indicator light | 3-23 |
| ECO gauge | 3-8 | Cruise control indicator light | 3-23 |
| Warning and indicator lights | 3-9 | Cruise control set indicator light | 3-23 |
| Seatbelt warning light and chime | 3-10 | Headlight indicator light | 3-23 |
| SRS airbag system warning light | 3-11 | Front fog light indicator light (if equipped) | 3-23 |
| Front passenger's frontal airbag ON and OFF indicators | 3-12 | Clock | 3-24 |
| CHECK ENGINE warning light/Malfunction indicator lamp | 3-12 | Multi function display | 3-24 |
| Coolant temperature low indicator light/Coolant temperature high warning light | 3-13 | Outside temperature indicator | 3-25 |
| Charge warning light | 3-14 | Average fuel consumption | 3-25 |
| Oil pressure warning light | 3-14 | Current fuel consumption | 3-26 |
| Engine low oil level warning light | 3-14 | Driving range on remaining fuel | 3-26 |

| | |
|---|-------------|
| Light control switch | 3-27 |
| Headlights..... | 3-27 |
| High/low beam change (dimmer)..... | 3-28 |
| Headlight flasher | 3-28 |
| Daytime running light system | 3-29 |
| Turn signal lever | 3-29 |
| Illumination brightness control | 3-30 |
| Front fog light switch (if equipped) | 3-30 |

| | |
|--|-------------|
| Wiper and washer | 3-31 |
| Windshield wiper and washer switches | 3-32 |
| Rear window wiper and washer switch (Outback) | 3-34 |
| Defogger and deicer | 3-34 |
| Mirrors | 3-36 |
| Inside mirror..... | 3-36 |
| Auto-dimming mirror/compass (if equipped) | 3-36 |
| Outside mirrors | 3-38 |
| Tilt/telescopic steering wheel | 3-38 |
| Horn | 3-39 |

Ignition switch

WARNING

- Never turn the ignition switch to “LOCK” while the vehicle is being driven or towed because that will lock the steering wheel, preventing steering control. And when the engine is turned off, it takes a much greater effort than usual to steer.
- Before leaving the vehicle, always remove the key from the ignition switch for safety and never allow an unattended child to remain in the vehicle. Failure to follow this procedure could result in injury to a child or others. Children could operate the power windows, the sunroof or other controls or even make the vehicle move.

CAUTION

Do not attach a large key holder or key case to either key. If it banged against your knees or hands while you are driving, it could turn the ignition switch from the “ON” posi-

tion to the “Acc” or “LOCK” position, thereby stopping the engine. Also, if the key is attached to a keyholder or to a large bunch of other keys, centrifugal force may act on it as the vehicle moves, resulting in unwanted turning of the ignition switch.

The ignition switch has four positions: LOCK, Acc, ON and START.

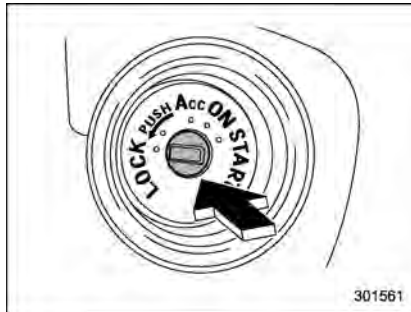

NOTE

- Keep the ignition switch in the “LOCK” position when the engine is not running.
- Using electrical accessories for a long time with the ignition switch in the “ON” or “Acc” position can cause the battery to go dead.

- If the ignition switch will not move from the “LOCK” position to the “Acc” position, turn the steering wheel slightly to the left and right as you turn the ignition switch.

■ LOCK

The key can only be inserted or removed in this position. The ignition switch will lock the steering wheel when you remove the key.

If turning the key is difficult, turn the steering wheel slightly to the right and left as you turn the key.

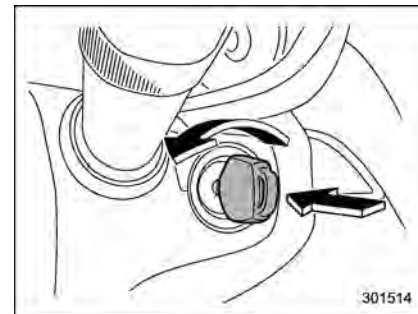

The key can be turned from “Acc” to “LOCK” only when the key is pushed in while turning it (all models) and the select lever is in the “P” position (AT and CVT models).

■ Acc

In this position the electrical accessories (radio, accessory power outlet, etc.) can be used.

■ ON

This is the normal operating position after the engine is started.

■ START

CAUTION

Do not turn the ignition switch to the "START" position while the engine is running.

The engine is started in this position. The starter cranks the engine to start it. When the key is released (after the engine has started), the key automatically returns to the "ON" position.

If the engine does not start with your registered key, pull out the key once (at this time, the security indicator light will blink), wait for at least 10 seconds, reinsert the key in the ignition switch and then try to start the engine again.

NOTE

The engine may not start in the following cases:

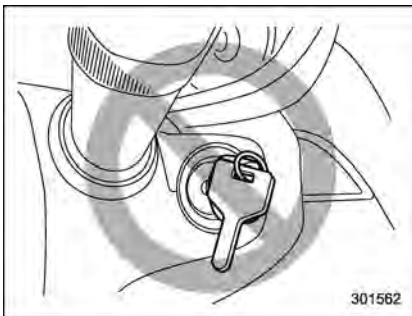

- The key grip is touching another key or a metallic key holder.

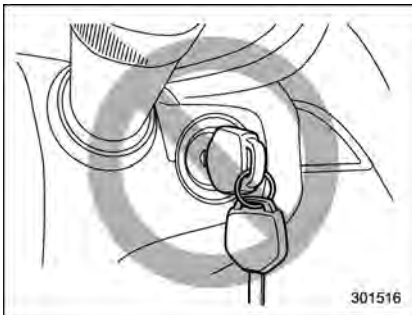

- The key is near another key that contains an immobilizer transponder.
- The key is near or touching another transmitter.

■ Key reminder chime

The reminder chime sounds when the driver's door opens and the key is in the "LOCK" or "Acc" positions. The chime stops when the ignition switch is turned to the "ON" position or the key is removed from the ignition switch.

■ Ignition switch light

For easy access to the ignition switch in the dark, the ignition switch light illuminates when driver's door is opened or when the driver's door is unlocked using the remote keyless entry transmitter.

The light remains illuminated for approximately 30 seconds and gradually turns off under the following conditions.

- When the driver's door is closed
- When the doors are unlocked using the remote keyless entry transmitter

The light gradually turns off under the following conditions.

- When the ignition switch is turned to the "ON" position
- When the doors are locked using the remote keyless entry transmitter

Hazard warning flasher

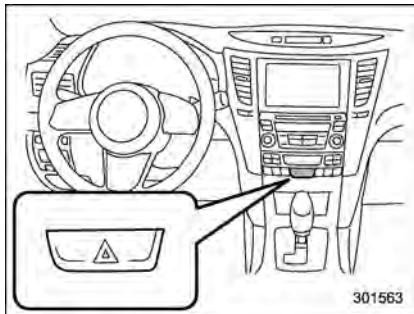

The hazard warning flasher is used to warn other drivers when you have to park your vehicle under emergency conditions. The hazard warning flasher works with the ignition switch in any position.

To turn on the hazard warning flasher, press the hazard warning button on the instrument panel. To turn off the flasher, press the button again.

NOTE

When the hazard warning flasher is on, the turn signals do not work.

Meters and gauges

NOTE

Liquid-crystal displays are used in some of the meters and gauges in the combination meter. You will find their indications hard to see if you wear polarized glasses.

■ Combination meter illumination

When the ignition switch is turned to the "ON" position, the various parts of the combination meter are illuminated in the following sequence.

1. Warning lights, indicator lights, meter needles, gauge needles, odometer and trip meter back light illuminate.
2. Meter needles and gauge needles each show MAX position.
3. Meter needles and gauge needles each show MIN position.
4. Dials and indicators in meters and gauges light up.
5. Regular illumination (for driving) begins.

NOTE

The above sequence of operations may not take place if you quickly turn the ignition switch to start the engine. This is not a malfunction.

■ Canceling the function for meter/gauge needle movement upon turning on the ignition switch

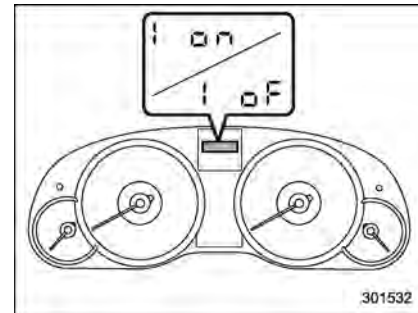

It is possible to activate or deactivate the movement of the meter needles and gauge needles that takes place when the ignition switch is turned to the "ON" position.

1. Turn the ignition switch to the "LOCK" or "Acc" position.
2. Press the trip knob to show "I ON" or

"i oF" on the trip meter display.

The display can be switched as shown in the following illustration by pressing the trip knob.

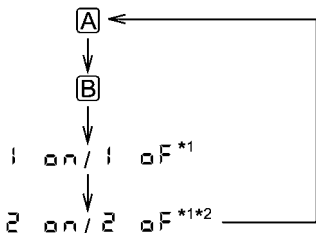

*1: "i o n" or "i o F" and "2 o n" or "2 o F" cannot be displayed when the ignition switch is in the "ON" position.

*2: MT models only

3. To change the current setting, press the trip knob for at least 2 seconds.

i o n : Activated

i o F : Deactivated

NOTE

- Your vehicle's initial movement setting of the meter/gauge needles has been set for activation "i o n" at the time of shipment from the factory.
- It is not possible to change the initial movement setting of the meter/gauge

needles when the ignition switch is in the "ON" position. Change the setting when the ignition switch is in the "LOCK" or "Acc" position.

Speedometer

The speedometer shows the vehicle speed.

Odometer

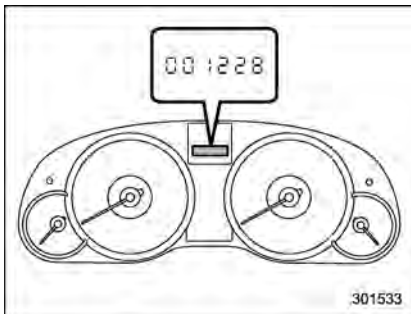

This meter displays the odometer when the ignition switch is in the "ON" position.

The odometer shows the total distance that the vehicle has been driven.

If you press the trip knob when the ignition switch is in the "LOCK" or "Acc" position, the odometer/trip meter will light up. If you do not press the trip knob within 10

seconds of illumination of the odometer/trip meter, the odometer/trip meter will turn off.

Also, if you open and close the driver's door within 10 seconds of illumination of the odometer/trip meter, the odometer/trip meter will turn off.

Double trip meter

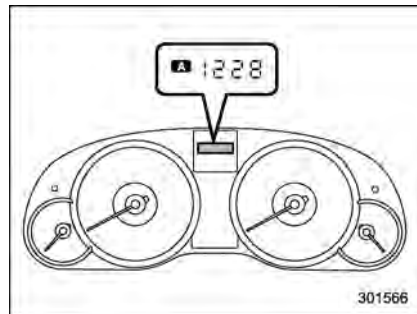

This meter displays the two trip meters when the ignition switch is in the "ON" position.

The trip meter shows the distance that the vehicle has been driven since you last set it to zero.

If you press the trip knob when the ignition switch is in the "LOCK" or "Acc" position, the odometer/trip meter will light up. It is

possible to switch between the A trip meter and B trip meter indications while the odometer/trip meter is lit up. If you do not press the trip knob within 10 seconds of illumination of the odometer/trip meter, the odometer/trip meter will turn off.

Also, if you open and close the driver's door within 10 seconds of illumination of the odometer/trip meter, the odometer/trip meter will turn off.

The display can be switched as shown in the following illustration by pressing the trip knob.

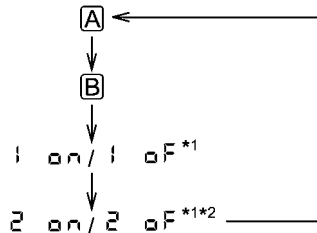

*1: "000" or "00F" and "2000" or "200F" cannot be displayed when the ignition switch is in the "ON" position.

*2: MT models only

To set the trip meter to zero, select the A trip or B trip meter by pressing the knob and keep the knob pressed for more than 2 seconds.

CAUTION

To ensure safety, do not attempt to change the function of the indicator during driving, as an accident could result.

NOTE

If the connection between the combination meter and battery is broken for any reason such as vehicle maintenance or fuse replacement, the data recorded on the trip meter will be lost.

■ Tachometer

The tachometer shows the engine speed in thousands of revolutions per minute.

CAUTION

Do not operate the engine with the pointer of the tachometer in the red zone. In this range, fuel injection will be cut by the engine control module to protect the engine from overrevving. The engine will resume running normally after the engine speed is reduced below the red zone.

NOTE

To protect the engine while the select lever is in the "P" or "N" position (for AT and CVT models) or the shift lever is in the neutral position (for MT models), the engine is controlled so that the engine speed may not become too high even if the accelerator pedal is pressed hard.

■ Fuel gauge

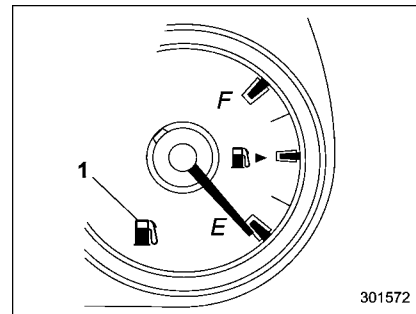

1) Low fuel warning light

The fuel gauge shows the approximate amount of fuel remaining in the tank.

When the ignition switch is in the "LOCK" or "Acc" position, the fuel gauge shows "E" even if the fuel tank contains fuel.

The gauge may move slightly during braking, turning or acceleration due to fuel level movement in the tank.

If you press the trip knob while the ignition switch is in the "LOCK" or "Acc" position, the fuel gauge's dial will light up and the needle will indicate the amount of fuel remaining in the tank.

If, while the fuel gauge needle is indicating the amount of fuel remaining in the tank, you (a) do not press the trip knob for 10 seconds or (b) open and close the driver's door, the fuel gauge needle will drop to the "E" position and the dial and needle will turn off.

NOTE

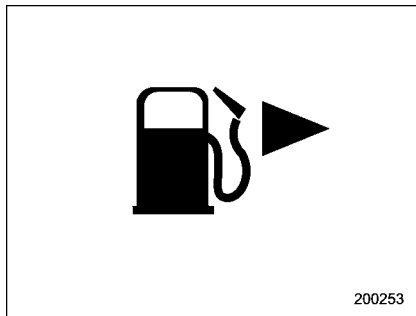

200253

You will see the "🚰▶" sign in the fuel

gauge.

This indicates that the fuel filler door (lid) is located on the right side of the vehicle.

▼ **Low fuel warning light**

The low fuel warning light illuminates when the fuel tank is nearly empty. It only operates when the ignition switch is in the "ON" position. When this light illuminates, fill the fuel tank immediately.



Promptly put fuel in the tank whenever the low fuel warning light illuminates. Engine misfires as a result of an empty tank could cause damage to the engine.

NOTE

- The low fuel warning light illuminates when the remaining amount of fuel in the tank has reached approximately 2.6 US gal (10 liters, 2.2 Imp. gal).
- The low fuel warning light does not turn off unless the tank is replenished up to a fuel quantity of approximately 4.0 US gal (15 liters, 3.3 Imp gal).

■ **ECO gauge**

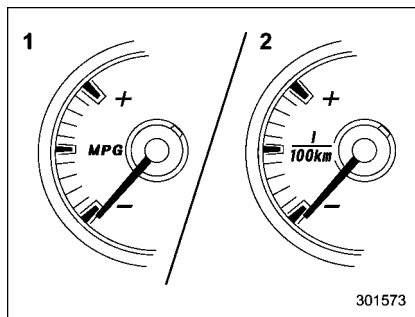

- 1) U.S.-spec. models
- 2) Except U.S.-spec. models

The ECO gauge shows the difference between the average rate of fuel consumption and the current rate of fuel consumption. Using the average rate of fuel consumption since the trip meter was last reset, the indicator needle behaves as described in the following items.

U.S.-spec. models:

If the current rate of fuel consumption is lower than the average rate of fuel consumption, the indicator needle points to the "+" side. If the current rate of fuel consumption is higher than the average rate of fuel consumption, the indicator needle points to the "-" side. When the

indicator needle is pointing to the “+” side, it indicates fuel-efficient driving.

Except U.S.-spec. models:

If the current rate of fuel consumption is lower than the average rate of fuel consumption, the indicator needle points to the “-” side. If the current rate of fuel consumption is higher than the average rate of fuel consumption, the indicator needle points to the “+” side. When the indicator needle is pointing to the “-” side, it indicates fuel-efficient driving.









NOTE

- The ECO gauge shows only an approximate indication.
- After resetting the trip meter, the average rate of fuel consumption is not shown until driving 0.6 mile (1 km). Until that time, the ECO gauge does not operate.

Warning and indicator lights

Several of the warning and indicator lights illuminate momentarily and then go out when the ignition switch is initially turned to the “ON” position. This permits checking the operation of the bulbs.

Apply the parking brake and turn the ignition switch to the “ON” position. The following lights illuminate:



-  Seatbelt warning light
(The seatbelt warning light turns off only when the driver fastens the seatbelt.)
-  Front passenger's seatbelt warning light
(The seatbelt warning light turns off only when the front seat passenger fastens the seatbelt.)
-  SRS airbag system warning light
-  CHECK ENGINE warning light/Malfunction indicator lamp
-  Coolant temperature high warning light
-  Charge warning light
-  Oil pressure warning light
-  Engine low oil level warning light
-  Windshield washer fluid warning light

 AT OIL TEMP warning light
(AT and CVT models)

 ABS /  ABS warning light

 Vehicle Dynamics Control warning light/Vehicle Dynamics Control operation indicator light



 Vehicle Dynamics Control OFF indicator light

 BRAKE /  Brake system warning light

 Hill Holder indicator light

 AWD: All-Wheel Drive warning light (AT and CVT models)

 Low tire pressure warning light
(U.S.-spec. models)

 ON /  Front passenger's frontal airbag ON indicator light

 OFF /  Front passenger's frontal airbag OFF indicator light

 Low fuel warning light

 Door open warning light

 Door open indicator light

 CRUISE: Cruise control indicator light

 SET: Cruise control set indicator light

 Select lever/gear position indicator

If any lights fail to illuminate, it indicates a burned-out bulb or a malfunction of the corresponding system.

Consult your authorized SUBARU dealer for repair.

■ Seatbelt warning light and chime



Your vehicle is equipped with a seatbelt warning device at the driver's and front passenger's seat, as required by current safety standards.

With the ignition switch turned to the "ON" position, this device reminds the driver and front passenger to fasten their seatbelts by the warning lights in the locations indicated in the following illustration and a chime.

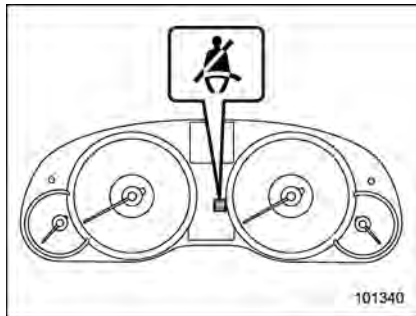

Driver's warning light

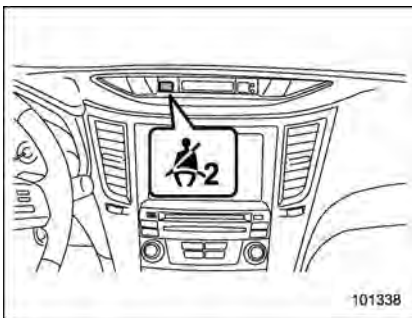

Front passenger's warning light

▼ Operation

If the driver and/or front passenger have/has not yet fastened the seatbelt(s) when the ignition switch is turned to the "ON" position, the seatbelt warning light(s) will flash for 6 seconds, to warn that the seatbelt(s) is/are unfastened. If the driver's seatbelt is not fastened, a chime will also sound simultaneously.

NOTE

- If the driver's and/or front passenger's seatbelt(s) are/is still not fastened 6 seconds later, the seatbelt warning device operates as follows according to the vehicle speed.

- At speeds lower than approximately 9 mph (15 km/h)

The warning light(s) for unfastened seatbelt(s) will alternate between steady illumination and flashing at 15-second intervals. The chime will not sound.

- At speeds higher than approximately 9 mph (15 km/h)

The warning light(s) for unfastened seatbelt(s) will alternate between flashing and steady illumination at 15-second intervals and the chime will sound while the warning light(s) is/are flashing.

- It is possible to cancel the warning operation that follows the 6-second warning after turning ON the ignition switch. When the ignition switch is turned ON next time, however, the complete sequence of the warning operation resumes. For further details about canceling the warning operation, please contact your SUBARU dealer.

If there is no passenger on the front passenger's seat, the seatbelt warning device for the front passenger's seat will be deactivated. The front passenger's occupant detection system monitors whether or not there is a passenger on the front passenger's seat. Observe the following precautions. Failure to do so may prevent the device from functioning correctly or cause the device to fail.

- Do not install any accessory such as a table or TV onto the seatback.
- Do not store a heavy load in the seatback pocket.
- Do not allow the rear seat occupant to place his/her hands or legs on the front passenger's seatback, or allow him/her to pull the seatback.
- Do not use front seats with their backward-forward position and seatback not being locked into place securely. If any of them are not locked securely, adjust them again. For adjusting procedure, refer to "Manual seat" 1-3 (models equipped with manual seats only).

If the seatbelt warning device for the front passenger's seat does not function correctly (e.g., it is activated even when the front passenger's seat is empty or it is deactivated even when the front passenger has not fastened his/her seatbelt), take the following actions.

- Ensure that no article is placed on the seat other than a child restraint system and its child occupant.
- Ensure that there is no article left in the seatback pocket.
- Ensure that the backward-forward position and seatback of front passenger's seat are locked into place securely by moving the seat back and forth. (Models

equipped with manual seats only)

If still the seatbelt warning device for front passenger's seat does not function correctly after taking relevant corrective actions described above, immediately contact your SUBARU dealer for an inspection.

■ SRS airbag system warning light



When the ignition switch is turned to the "ON" position, the SRS airbag system warning light will illuminate for approximately 6 seconds and turn off. This shows the SRS frontal airbag and SRS side airbag and SRS curtain airbag and seatbelt pretensioners are in normal operation.



WARNING

If the warning light exhibits any of the following conditions, there may be a malfunction in the seatbelt pretensioners and/or SRS airbag system. Immediately take your vehicle to your nearest SUBARU dealer to have the system checked. Unless checked and properly repaired, the seatbelt pretensioners and/or SRS airbags will operate improperly (e.g. SRS airbags may inflate in a very

minor collision or not inflate in a severe collision), which may increase the risk of injury.

- **Flashing or flickering of the warning light**
- **No illumination of the warning light when the ignition switch is first turned to the "ON" position**
- **Continuous illumination of the warning light**
- **Illumination of the warning light while driving**

■ Front passenger's frontal airbag ON and OFF indicators



ON / : Front passenger's frontal airbag ON indicator

OFF / : Front passenger's frontal airbag OFF indicator

The front passenger's frontal airbag ON and OFF indicators show you the status of the front passenger's SRS frontal airbag. The indicators are located next to the clock in the center portion of the dashboard.

When the ignition switch is turned to the "ON" position, both the ON and OFF indicators illuminate for 6 seconds during which time the system is checked. Following the system check, both indicators turn off for 2 seconds. After that, one of the

indicators illuminates depending on the status of the front passenger's SRS frontal airbag determined by the SUBARU advanced frontal airbag system monitoring.

If the front passenger's SRS frontal airbag is activated, the passenger's frontal airbag ON indicator will illuminate while the OFF indicator will remain off.

If the front passenger's SRS frontal airbag is deactivated, the passenger's frontal airbag ON indicator will remain off while the OFF indicator will illuminate.

With the ignition switch turned to the "ON" position, if both the ON and OFF indicators remain illuminated or off simultaneously even after the system check period, the system is malfunctioning. Contact your SUBARU dealer immediately for an inspection.

■ CHECK ENGINE warning light/Malfunction indicator lamp

CHECK
ENGINE

 CAUTION

If the CHECK ENGINE warning light/malfunction indicator lamp illuminates while you are driving, have your vehicle checked/repaired by your SUBARU dealer as soon as possible. Continued vehicle opera-

tion without having the emission control system checked and repaired as necessary could cause serious damage, which may not be covered by your vehicle's warranty.

If this light illuminates steadily or blinks while the engine is running, it may indicate that there is a problem or potential problem somewhere in the emission control system.

▼ If the light illuminates steadily

If the light illuminates steadily while driving or does not turn off after the engine starts, an emission control system malfunction has been detected.

You should have your vehicle checked by an authorized SUBARU dealer immediately.

NOTE

This light also illuminates when the fuel filler cap is not tightened until it clicks.

If you have recently refueled your vehicle, the cause of the CHECK ENGINE warning light/malfunction indicator lamp coming on could be a loose or missing fuel filler cap. Remove the cap and retighten it until it clicks. Make sure nothing is interfering with the sealing of the cap. Tightening the cap will not make the CHECK ENGINE

warning light/malfunction indicator lamp turn off immediately. It may take several driving trips. If the light does not turn off, take your vehicle to your authorized SUBARU dealer immediately.

▼ If the light is blinking

If the light is blinking while driving, an engine misfire condition has been detected which may damage the emission control system.

To prevent serious damage to the emission control system, you should conform to the following instructions.

- Reduce vehicle speed.
- Avoid hard acceleration.
- Avoid steep uphill grades.
- Reduce the amount of cargo, if possible.
- Stop towing a trailer as soon as possible.

The CHECK ENGINE warning light/malfunction indicator lamp may stop blinking and illuminate steadily after several driving trips. You should have your vehicle checked by an authorized SUBARU dealer immediately.

■ Coolant temperature low indicator light/Coolant temperature high warning light

CAUTION

- After turning the ignition switch to the "ON" position, if this indicator light/warning light behaves under any of the following conditions, the electrical system may be malfunctioning. Contact your SUBARU dealer immediately for an inspection.
 - It remains blinking in RED.
 - It remains illuminated in RED for more than 2 seconds.
 - It remains blinking in RED and BLUE alternately.
- While driving, if this indicator light/warning light behaves under any of the following conditions, take the specified appropriate measure listed below.
 - **Blinking in RED:**
Decelerate the vehicle. After the blinking RED light turns off, you can drive the vehicle normally.
 - **Illuminated in RED:**

Safely stop the vehicle as soon as possible, and refer to the emergency steps for the case of engine overheating. After that, have the system checked by your nearest SUBARU dealer. Refer to "Engine overheating" 9-12.

- **Blinking in RED and BLUE alternately:**
The electrical system may be malfunctioning. Contact your SUBARU dealer for an inspection.

This coolant temperature low indicator light/coolant temperature high warning light has the following three functions.

- Illumination in **BLUE** indicates insufficient warming up of the engine
- Blinking in **RED** indicates that the engine is close to overheating
- Illumination in **RED** indicates overheating condition of the engine

For the system check, this indicator light/warning light illuminates in **RED** for approximately 2 seconds when the ignition switch is turned to the "ON" position. After that, this indicator light/warning light changes to **BLUE** and maintains illumination in **BLUE**. This **BLUE** illuminated light

turns off when the engine is warmed up sufficiently.

If the engine coolant temperature increases over the appropriate range, the indicator light/warning light blinks in **RED**. At this time, decelerate the vehicle. After the blinking **RED** light turns off, you can drive the vehicle normally. However, if the indicator light/warning light often blinks in **RED**, the electrical system may be malfunctioning. Contact your SUBARU dealer for an inspection.

If the engine coolant temperature increases further, the indicator light/warning light illuminates in **RED** continuously. At this time, the engine may be overheating. Safely stop the vehicle as soon as possible, and refer to the emergency steps for the case of engine overheating. Refer to "Engine overheating" 9-12. After that, have the system checked by your nearest SUBARU dealer.

NOTE

If the engine is restarted after a certain driving condition, this indicator light/warning light may illuminate in RED. However, this is not a malfunction if the indicator light/warning light turns off after a short time.

■ **Charge warning light** 

If this light illuminates when the engine is running, it may indicate that the charging system is not working properly.

If the light illuminates while driving or does not turn off after the engine starts, stop the engine at the first safe opportunity and check the alternator belt. If the belt is loose, broken or if the belt is in good condition but the light remains illuminated, contact your nearest SUBARU dealer immediately.

■ **Oil pressure warning light** 

 **CAUTION**

Do not operate the engine with the oil pressure warning light on. This may cause serious engine damage.

If this light illuminates when the engine is running, it may indicate that the engine oil pressure is low and the lubricating system is not working properly.

If the light illuminates while driving or does not turn off after the engine starts, stop the engine at the first safe opportunity and check the engine oil level. If the oil level is low, add oil immediately. If the engine oil is

at the proper level but the light remains illuminated, contact your nearest SUBARU dealer immediately.

■ **Engine low oil level warning light** 

The engine low oil level warning light illuminates when the ignition switch is turned to the "ON" position and turns off after approximately 2 seconds.

This light also illuminates when the engine oil level decreases to the lower limit. The illuminating conditions and remaining oil level are shown in the following items.

2.5 L models:

- when the ignition switch is in the "ON" position but the engine is not running: approximately 1.9 US qt (1.8 liters, 1.6 Imp qt)
- while the engine is running: approximately 3.2 US qt (3.0 liters, 2.6 Imp qt)

3.6 L models:

- when the ignition switch is in the "ON" position but the engine is not running: approximately 4.0 US qt (3.8 liters, 3.3 Imp qt)
- while the engine is running: approximately 5.6 US qt (5.3 liters, 4.7 Imp qt)

If the engine low oil level warning light illuminates while driving, park the vehicle

at a safe and level location, and then check the engine oil level. When the engine oil level is not within the normal range, refill with engine oil if necessary. Refer to "Engine oil"  11-12.

If the warning light does not turn off after refilling with engine oil or the warning light illuminates even though the engine oil level is within the normal range, have the system checked by a SUBARU dealer.

NOTE

- **The engine low oil level warning light will not turn off immediately even if you replace or add engine oil. It will turn off only when the vehicle is idling and the engine is warmed up completely.**

- **When the vehicle is considerably inclined on an uphill or steep slope, the warning light may illuminate temporarily due to the movement of engine oil in the engine.**

■ AT OIL TEMP warning light (AT and CVT models) AT OIL TEMP

The AT oil temperature warning light "AT OIL TEMP" illuminates when the ignition switch is turned to the "ON" position and turns off after approximately 2 seconds.

If this light illuminates when the engine is running, it may indicate that the transmission fluid temperature is too hot.

If the light illuminates while driving, immediately stop the vehicle in a safe place and let the engine idle until the warning light turns off.

▼ Transmission control system warning

If the "AT OIL TEMP" warning light flashes after the engine has started, it may indicate that the transmission control system is not working properly. Contact your nearest SUBARU dealer for service immediately.

■ Low tire pressure warning light (U.S.-spec. models)

When the ignition switch is turned to the "ON" position, the low tire pressure warning light will illuminate for approximately 2 seconds to check that the tire pressure monitoring system (TPMS) is functioning properly. If there is no problem and all tires are properly inflated, the light will go out.

Each tire, including the spare (if provided), should be checked monthly when cold and inflated to the inflation pressure recommended by the vehicle manufacturer on the vehicle placard or tire inflation

pressure label. (If your vehicle has tires of a different size than the size indicated on the vehicle placard or tire inflation pressure label, you should determine the proper tire inflation pressure for those tires.)

As an added safety feature, your vehicle has been equipped with a tire pressure monitoring system (TPMS) that illuminates a low tire pressure telltale when one or more of your tires is significantly under-inflated. Accordingly, when the low tire pressure telltale illuminates, you should stop and check your tires as soon as possible, and inflate them to the proper pressure. Driving on a significantly under-inflated tire causes the tire to overheat and can lead to tire failure. Under-inflation also reduces fuel efficiency and tire tread life, and may affect the vehicle's handling and stopping ability.

Please note that the TPMS is not a substitute for proper tire maintenance, and it is the driver's responsibility to maintain correct tire pressure, even if under-inflation has not reached the level to trigger illumination of the TPMS low tire pressure telltale.

Your vehicle has also been equipped with a TPMS malfunction indicator to indicate when the system is not operating properly. The TPMS malfunction indicator is com-

bined with the low tire pressure telltale. When the system detects a malfunction, the telltale will flash for approximately one minute and then remain continuously illuminated. This sequence will continue upon subsequent vehicle start-ups as long as the malfunction exists. When the malfunction indicator is illuminated, the system may not be able to detect or signal low tire pressure as intended. TPMS malfunctions may occur for a variety of reasons, including the installation of replacement or alternate tires or wheels on the vehicle that prevent the TPMS from functioning properly. Always check the TPMS malfunction telltale after replacing one or more tires or wheels on your vehicle to ensure that the replacement or alternate tires and wheels allow the TPMS to continue to function properly.

Should the warning light illuminate steadily after blinking for approximately one minute, have the system inspected by your nearest SUBARU dealer as soon as possible.

**WARNING**

If this light does not illuminate briefly after the ignition switch is turned ON or the light illuminates steadily after blinking for approximately one minute, you should have

your Tire Pressure Monitoring System checked at a SUBARU dealer as soon as possible.

If this light illuminates while driving, never brake suddenly and keep driving straight ahead while gradually reducing speed. Then slowly pull off the road to a safe place. Otherwise an accident involving serious vehicle damage and serious personal injury could occur.

If this light still illuminates while driving after adjusting the tire pressure, a tire may have significant damage and a fast leak that causes the tire to lose air rapidly. If you have a flat tire, replace it with a spare tire as soon as possible.

When a spare tire is mounted or a wheel rim is replaced without the original pressure sensor/transmitter being transferred, the Low tire pressure warning light will illuminate steadily after blinking for approximately one minute. This indicates the TPMS is unable to monitor all four road wheels. Contact your SUBARU dealer as soon as possible for tire and sensor replacement and/or system resetting. If the light illuminates steadily after blinking for approximately one minute,

promptly contact a SUBARU dealer to have the system inspected.

**CAUTION**

The tire pressure monitoring system is NOT a substitute for manually checking tire pressure. The tire pressure should be checked periodically (at least monthly) using a tire gauge. After any change to tire pressure(s), the tire pressure monitoring system will not re-check tire inflation pressures until the vehicle is first driven more than 20 mph (32 km/h). After adjusting the tire pressures, increase the vehicle speed to at least 20 mph (32 km/h) to start the TPMS re-checking of the tire inflation pressures. If the tire pressures are now above the severe low pressure threshold, the low tire pressure warning light should turn off a few minutes later. Therefore, be sure to install the specified size for the front and rear tires.

■ ABS warning light 

The ABS warning light illuminates when the ignition switch is turned to the "ON"

position and turns off after approximately 2 seconds.

This is an indication that the ABS system is working properly.

CAUTION

If the warning light behaves as follows, the ABS system may not work properly.

When the warning light illuminates, the ABS function shuts down; however, the conventional brake system continues to operate normally.

- The warning light does not illuminate when the ignition switch is turned to the “ON” position.
- The warning light illuminates when the ignition switch is turned to the “ON” position, but it does not turn off even when the vehicle speed exceeds approximately 8 mph (12 km/h).
- The warning light illuminates during driving.

If any of these conditions occur, have the ABS system repaired at the first available opportunity by your SUBARU dealer.

The ABS warning light illuminates to-

gether with the brake system warning light if the EBD system malfunctions. For further details of the EBD system malfunction warning, refer to “Brake system warning light”  3-17.

NOTE

If the warning light behavior is as described in the following conditions, the ABS system may be considered normal.

- The warning light illuminates right after the engine is started but turns off immediately, remaining off.
- The warning light remains illuminated after the engine has been started, but it turns off when the vehicle speed reaches approximately 8 mph (12 km/h).
- The warning light illuminates during driving, but it turns off immediately and remains off.

When driving with an insufficient battery voltage such as when the engine is jump started, the ABS warning light may illuminate. This is due to the low battery voltage and does not indicate a malfunction. When the battery becomes fully charged, the light will turn off.

■ Brake system warning light

BRAKE / 

WARNING

- Driving with the brake system warning light on is dangerous. This indicates your brake system may not be working properly. If the light remains illuminated, have the brakes inspected by a SUBARU dealer immediately.
- If at all in doubt about whether the brakes are operating properly, do not drive the vehicle. Have your vehicle towed to the nearest SUBARU dealer for repair.
- If the brake system warning light flashes, the electronic parking brake system may be malfunctioning. Immediately stop your vehicle in a safe location, use tire stops under the tires to prevent the vehicle from moving and contact your SUBARU dealer. For details, refer to “Electronic parking brake”  7-34.

NOTE

- When the ignition switch is turned to the “LOCK” position with the electronic parking brake applied, the brake system warning light remains illuminated for approximately 30 seconds and then turns off.
- When the electronic parking brake switch is pressed to apply the electronic parking brake while the ignition switch is in the “LOCK” position, the brake system warning light illuminates, remains illuminated for approximately 30 seconds and then turns off.
- Even if the brake system warning light flashes, if the warning light behavior is as described in the following examples, the electronic parking brake system is not malfunctioning.
 - The warning light turns off when the electronic parking brake is applied or released.
 - The warning light turns off when the ignition switch is turned to the “ON” position again.
- The brake system warning light may flash when the engine is started immediately after the electronic parking brake is applied or released. However, the electronic parking brake system is not malfunctioning if the warning light turns off after the electronic parking

brake is applied or released after that.

- The brake system warning light may flash after the electronic parking brake is frequently applied and released. However, the electronic parking brake system is not malfunctioning if the light turns off for a short period of time.

This light has the following functions:

▼ **Parking brake warning**

The light illuminates with the parking brake applied while the ignition switch is in the “ON” position. It turns off when the parking brake is fully released.

▼ **Brake fluid level warning**

This light illuminates when the brake fluid level has dropped to near the “MIN” level of the brake fluid reservoir with the ignition switch in the “ON” position and with the parking brake fully released.

If the brake system warning light should illuminate while driving (with the parking brake fully released and with the ignition switch positioned in “ON”), it could be an indication of leaking of brake fluid or worn brake pads. If this occurs, immediately stop the vehicle at the nearest safe place and check the brake fluid level. If the fluid level is below the “MIN” mark in the reservoir, do not drive the vehicle. Have the vehicle towed to the nearest SUBARU

dealer for repair.

▼ **Electronic Brake Force Distribution (EBD) system warning**

The brake system warning light also illuminates if a malfunction occurs in the EBD system. In that event, it illuminates together with the ABS warning light.

The EBD system may be malfunctioning if the brake system warning light and ABS warning light illuminate simultaneously during driving.

Even if the EBD system fails, the conventional braking system will still function. However, the rear wheels will be more prone to locking when the brakes are applied harder than usual and the vehicle’s motion may therefore become somewhat harder to control.

If the brake system warning light and ABS warning light illuminate simultaneously, take the following steps:

1. Stop the vehicle in the nearest safe, flat place.
 2. Shut down the engine, then restart it.
 3. Release the parking brake. If both warning lights turn off, the EBD system may be malfunctioning.
- Drive carefully to the nearest SUBARU dealer and have the system inspected.
4. If both warning lights illuminate again and remain illuminated after the engine

has been restarted, shut down the engine again, apply the parking brake, and check the brake fluid level.

5. If the brake fluid level is not below the "MIN" mark, the EBD system may be malfunctioning. Drive carefully to the nearest SUBARU dealer and have the system inspected.

6. If the brake fluid level is below the "MIN" mark, DO NOT drive the vehicle. Instead, have the vehicle towed to the nearest SUBARU dealer for repair.

▼ Electronic parking brake system warning

The brake system warning light flashes when the electronic parking brake system is malfunctioning. If the warning light flashes, promptly park in a safe location as soon as possible and contact your SUBARU dealer.

The brake system warning light remains illuminated when the parking brake cannot be released even if the parking brake switch is pulled. For details, refer to "Electronic parking brake" 7-34.

▼ Parking brake apply inhibit warning

The brake system warning light flashes for 10 seconds and a chirp sound will be heard if the parking brake switch is operated when the parking brake cannot

be applied.

▼ Frequent operation warning

The brake system warning light flashes for 20 seconds and a chirp sound will be heard if the parking brake switch is operated too frequently. In this case, the operation of the parking brake switch is restricted to protect the electronic parking brake system.

NOTE

Wait until the warning light turns off.

▼ Emergency released warning

The brake system warning light flashes when the parking brake is automatically released in case of an emergency.

■ Hill Holder indicator light



WARNING

If the Hill Holder indicator light does not illuminate even when the Hill Holder switch is pressed to activate the Hill Holder function, the electronic parking brake system may be malfunctioning. Immediately stop the vehicle in a safe location and contact your SUBARU dealer.

The light illuminates when the ignition switch is turned to the "ON" position and turns off after approximately 2 seconds.

The light illuminates when the Hill Holder switch is pressed to activate the Hill Holder function.

■ Low fuel warning light



The low fuel warning light illuminates when the tank is nearly empty (approximately 2.6 US gal (10.0 liters), or 2.2 Imp gal). It only operates when the ignition switch is in the "ON" position.

NOTE

This light does not turn off unless the tank is replenished up to an internal fuel quantity of approximately 3.7 US gal (14 liters, 3.1 Imp gal).

CAUTION

Promptly put fuel in the tank whenever the low fuel warning light illuminates. Engine misfires as a result of an empty tank could cause damage to the engine.

■ Door open warning light



When the ignition switch is in the "ON" position, the door open warning light illuminates for approximately 2 seconds and then turns off.

The door open warning light illuminates if any door, the rear gate (Outback) or trunk lid (Legacy) is not fully closed. This function is effective even if the ignition switch is in the "LOCK" or "Acc" position or the key is removed from the ignition switch.

Always make sure this light is not illuminated before you start to drive.

■ Door open indicator light



When any of the doors, the rear gate (Outback) or the trunk lid (Legacy) is not fully closed, the door open indicator light illuminates. This function is effective even if the ignition switch is in the "LOCK" or "Acc" position or the key is removed from the ignition switch.

The open door is indicated by the corresponding part of the door open warning light.

Always make sure this light is not illuminated before you start to drive.

■ Windshield washer fluid warning light



This light illuminates when the fluid level in the windshield washer fluid tank decreases to the lower limit (approximately 0.6 US qt, 0.6 liter, 0.5 Imp qt).

■ All-Wheel Drive warning light (AT and CVT models)

AWD

▲ WARNING

Continued driving with the AWD warning light flashing can lead to powertrain damage. If the AWD warning light flashes, promptly park in a safe place then check whether all four tires are the same diameter and whether any of the tires has a puncture or has lost air pressure for some other reason.

The All-Wheel Drive warning light illuminates when the ignition switch is turned to the "ON" position and turns off after the engine has started.

▼ For AT models

This light flashes if the vehicle is driven with tires of different diameters fitted on its wheels or with the air pressure exces-

sively low in any of its tires.

▼ For CVT models

This light illuminates when All-Wheel Drive is disengaged and the drive mechanism is switched to Front Wheel Drive for maintenance or similar purposes.

This light flashes if the vehicle is driven with tires of different diameters fitted on its wheels or with the air pressure excessively low in any of its tires.

■ Vehicle Dynamics Control warning light/ Vehicle Dynamics Control operation indicator light



The light illuminates when the ignition switch is turned to the "ON" position and turns off several seconds after the engine has started. This lighting pattern indicates that the Vehicle Dynamics Control system is operating normally.

▼ Vehicle Dynamics Control warning light

▲ CAUTION

The Vehicle Dynamics Control system provides its ABS control through the electrical circuit of the

ABS system. Accordingly, if the ABS is inoperative, the Vehicle Dynamics Control system becomes unable to provide ABS control. As a result, the Vehicle Dynamics Control system also becomes inoperative, causing the warning light to illuminate. Though both the Vehicle Dynamics Control and ABS systems are inoperative in this case, the ordinary functions of the brake system are still available. You will be safe while driving with this condition, but drive carefully and have your vehicle checked at a SUBARU dealer as soon as possible.

NOTE

- If the electrical circuit of the Vehicle Dynamics Control system itself malfunctions, the warning light only illuminates. At this time, the ABS (Anti-lock Brake System) remains fully operational.
- The warning light illuminates when the electronic control system of the ABS/Vehicle Dynamics Control system malfunctions.

The Vehicle Dynamics Control system is probably inoperative under any of the following conditions. Have your vehicle

checked at a SUBARU dealer immediately.

- The warning light does not illuminate when the ignition switch is turned to the "ON" position.
- The warning light illuminates while the vehicle is running.

NOTE

If the warning light behavior is as described in the following examples, the Vehicle Dynamics Control system may be considered normal.

- The warning light illuminates right after the engine is started but turns off immediately, remaining off.
- The warning light illuminates after the engine has started and turns off while the vehicle is subsequently being driven.
- The warning light illuminates during driving, but it turns off immediately and remains off.

▼ Vehicle Dynamics Control operation indicator light

The indicator light flashes during activation of the skid suppression function and during activation of the traction control function.

NOTE

- The light may remain illuminated for a short period of time after the engine has been started, especially in cold weather. This does not indicate the existence of a problem. The light should turn off as soon as the engine has warmed up.
- The indicator light illuminates when the engine has developed a problem and the CHECK ENGINE warning light/malfunction indicator lamp is on.

The Vehicle Dynamics Control system is probably malfunctioning under the following condition. Have your vehicle checked at a SUBARU dealer as soon as possible.

- The light does not turn off even after the lapse of several minutes (the engine has warmed up) after the engine has started.

■ Vehicle Dynamics Control OFF indicator light



The light illuminates when the ignition switch is turned to the "ON" position and turns off after approximately 2 seconds. The light illuminates when the Vehicle Dynamics Control OFF switch is pressed to deactivate the Vehicle Dynamics Control system.

The Vehicle Dynamics Control system is probably malfunctioning under any of the following conditions. Have your vehicle checked at a SUBARU dealer immediately.

- The light does not illuminate when the ignition switch is turned to the "ON" position.
- The light does not turn off even after a period of approximately 2 seconds after the ignition switch has been turned to the "ON" position.

■ Security indicator light

This indicator light shows the status of the alarm system. It also indicates operation of the immobilizer system.

▼ Alarm system

It blinks to show the driver the operational status of the alarm system. For detailed information, refer to "Alarm system" 2-16.

▼ Immobilizer system

This light blinks approximately 60 seconds after the ignition switch is turned from "ON" position to the "Acc" or "LOCK" position or immediately after the key is pulled out. Refer to "Immobilizer" 2-3.

If the indicator light does not flash, it may indicate that immobilizer system may be

faulty. Contact your nearest SUBARU dealer immediately.

In the event that an unauthorized key (for example, an unauthorized duplicate) is used, the security indicator light illuminates.

■ Select lever/gear position indicator

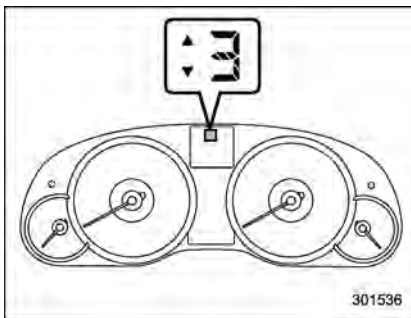

This indicator shows the position of the shift lever (MT models) or select lever (AT and CVT models).

▼ AT and CVT models

When the manual mode is selected, the gear position indicator (which shows the current gear selection) and the upshift/downshift indicator light up. Refer to

"Automatic transmission/Continuously variable transmission" 7-18.

▼ MT models

The shift-up indicator light illuminates and informs the driver about the upshift timing for fuel-efficient driving.

The gear position indicator light and the shift-up indicator can be activated or deactivated by performing the following procedure.

1. Turn the ignition switch to the "LOCK" position.
2. Press the trip knob to show "2 ON" or "2 OF" on the trip meter display.

The display can be switched as shown in the following illustration by pressing the trip knob.

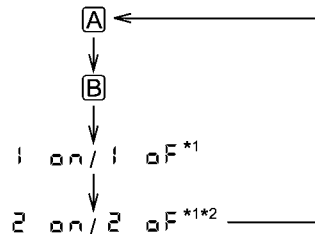

*1: "2 ON" or "2 OF" and "2 ON" or "2 OF" cannot be displayed when the ignition switch is in the "ON" position.

*2: MT models only

3. To change the current setting, press the trip knob for at least 2 seconds.

2 ON : Activated

2 OFF : Deactivated

NOTE

- The initial setting for your vehicle of the gear position indicator and shift-up indicator has been set for activation “2 ON” at the time of shipment from the factory.
- It is not possible to change the setting of the gear position indicator/shift-up indicator when the ignition switch is in the “ON” position. Change the setting when the ignition switch is in the “LOCK” or “Acc” position.

Turn signal indicator lights

These lights show the operation of the turn signal or lane change signal.

If the indicator lights do not blink or blink rapidly, the turn signal bulb may be burned out. Replace the bulb as soon as possible. Refer to “Replacing bulbs” 11-50.

High beam indicator light



This light shows that the headlights are in the high beam mode.

This indicator light also illuminates when the headlight flasher is operated.

Cruise control indicator light



The cruise control indicator light illuminates when the ignition switch is turned to the “ON” position and turns off after approximately 3 seconds.

This light illuminates when the “CRUISE” main switch is pressed.

NOTE

- If you move the cruise control lever or press the main switch button while turning the ignition switch “ON”, the cruise control function is deactivated and the “CRUISE” indicator light flashes. To reactivate the cruise control function, turn the ignition switch back to the “Acc” or “LOCK” position, and then turn it again to the “ON” position.
- If this indicator light and the CHECK ENGINE warning light/malfunction indicator lamp flash simultaneously during driving, have the vehicle checked by your nearest SUBARU dealer.

Cruise control set indicator light



The cruise control set indicator light illuminates when the ignition switch is turned to the “ON” position and turns off after approximately 3 seconds.

This light illuminates when vehicle speed has been set.

Headlight indicator light



This indicator light illuminates under the following conditions.

- when the light switch is turned to the “300E” or “D” position
- when the light switch is in the “AUTO” position and the headlights illuminate automatically

Front fog light indicator light (if equipped)



This indicator light illuminates while the front fog lights are illuminated.

Clock

NOTE

Your SUBARU dealer can change the settings of activating/deactivating the automatic adjustment of the clock by the GPS (Global Positioning System) (for models with the genuine SUBARU navigation system). Contact your SUBARU dealer for details.

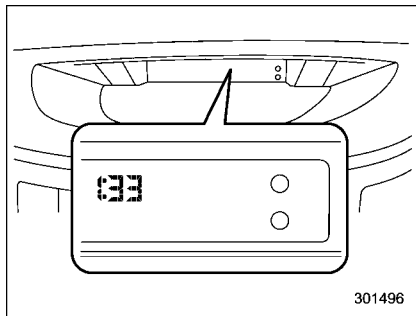

The clock shows the time while the ignition switch is in the "Acc" or "ON" position.

To adjust the time shown by the clock, press the "+" button or the "-" button. If you press the "+" button, the indicated time will change in one-minute increments. If you press the "-" button, the

indicated time will change in one-minute decrements. If you keep the button pressed, the rate at which the indicated time changes will speed up.

Multi function display

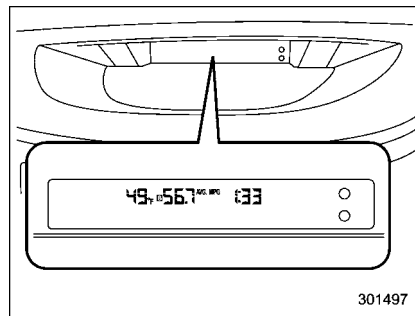

With the ignition switch in the "ON" position, each successive press of the multi function display switching knob toggles the display in the following sequence.

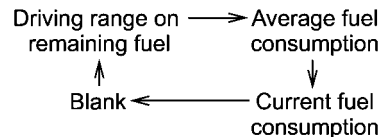

■ Outside temperature indicator

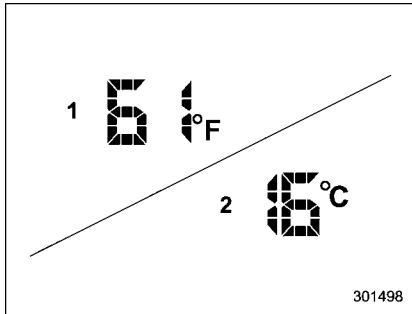

- 1) U.S.-spec. models
- 2) Except U.S.-spec. models

The outside temperature indicator shows the outside temperature in a range from -22 to 122°F (-30 to 50°C).

The indicator can give a false reading under any of the following conditions:

- When there is too much sun.
- During idling; while running at low speeds in a traffic jam; when the engine is restarted immediately following a shut-down.
- When the actual outside temperature falls outside the specified indicator range.

▼ Road surface freeze warning indication

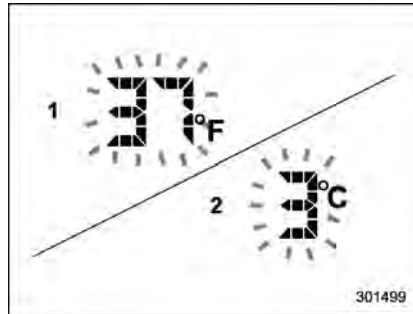

- 1) U.S.-spec. models
- 2) Except U.S.-spec. models

When the outside temperature drops to 37°F (3°C) or lower, the temperature indication flashes to show that the road surface may be frozen.

If the outside temperature drops to 37°F (3°C) or lower while the display is giving an indication other than the outside temperature, the display switches to the outside temperature indication and flashes for 5 seconds before returning to its original indication.

If the display is already indicating an outside temperature of 37°F (3°C) or lower when the ignition switch is turned to the

“ON” position, the indication does not flash.

NOTE

The outside temperature indication may differ from the actual outside temperature. The road surface freeze warning indication should be treated only as a guide. Be sure to check the condition of the road surface before driving.

■ Average fuel consumption

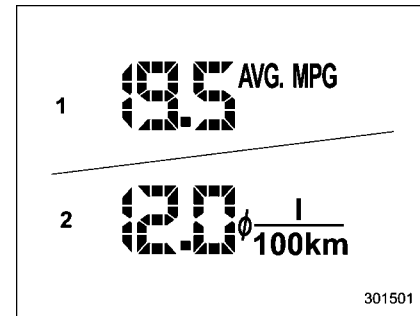

- 1) U.S.-spec. models
- 2) Except U.S.-spec. models

This indication shows the average rate of fuel consumption since the trip meter was last reset.

Pressing the trip knob toggles the indication between the average fuel consumption corresponding to the A trip meter indication and the average fuel consumption corresponding to the B trip meter indication.

When either of the trip meter indications is reset, the corresponding average fuel consumption value is also reset.

NOTE

- The indicated values vary in accordance with changes in the vehicle's running conditions. Also, the indicated values may differ slightly from the actual values and should thus be treated only as a guide.
- When either trip meter indication is reset, the average fuel consumption corresponding to that trip meter indication is not shown until the vehicle has subsequently covered a distance of 1 mile (or 1 km).

■ Current fuel consumption

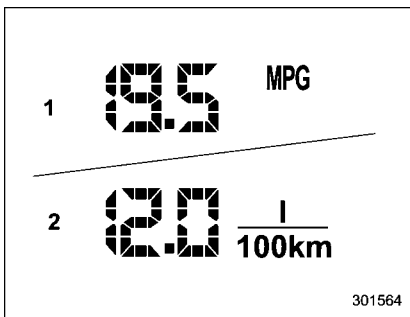

- 1) U.S.-spec. models
- 2) Except U.S.-spec. models

This indication shows the rate of fuel consumption at the present moment.

■ Driving range on remaining fuel

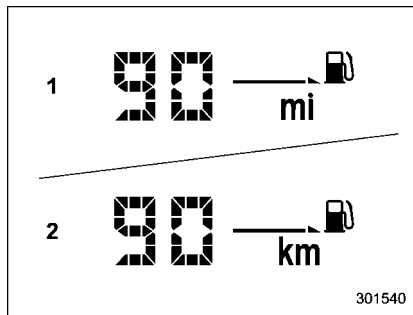

- 1) U.S.-spec. models
- 2) Except U.S.-spec. models

The driving range indicates the distance that can be driven taking into account the amount of fuel remaining in the tank and the average rate of fuel consumption.

When the low fuel warning light illuminates, the driving range indication flashes for 5 seconds. (The display first switches to the driving range indication if it was originally giving some other indication.)

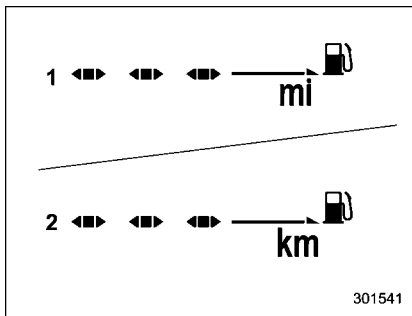

- 1) U.S.-spec. models
- 2) Except U.S.-spec. models

If the driving range is shown as “---”, there is only a tiny amount of fuel left in the tank. You must refuel the vehicle immediately.

NOTE



The driving range on remaining fuel is only a guide. The indicated value may differ from the actual driving range on remaining fuel, so you must immediately fill the tank when the low fuel warning light illuminates.

Light control switch

The light control switch only operates when the key is inserted into the ignition switch.

Regardless of the position of the light control switch, the illuminated lights are turned off when the key is removed from the ignition switch.

NOTE

- Even if the key is removed from the ignition switch, the lights can be illuminated by operating the light control switch position from “OFF” to “”, and/or “”.
- If the driver’s door is opened while the lights are illuminated and the key is removed from the ignition switch, the chirp sound informs the driver that the lights are illuminated.

CAUTION

- Use of any lights for a long period of time while the engine is not running can cause the battery to discharge.
- Before leaving the vehicle, make sure that the light control switch is turned to the “OFF” position. If the vehicle is left unattended for

a long time with the light control switch set to a position other than “OFF”, the battery may be discharged.

Headlights

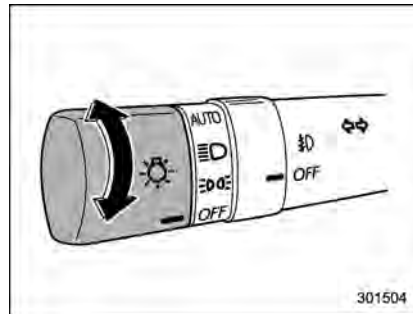

To turn on the headlights, turn the knob on the end of the turn signal lever.

first position

Instrument panel illumination, tail lights, front side marker lights and license plate lights are on.

second position

Headlights, instrument panel illumination, front side marker lights, tail lights and license plate lights are on.

AUTO: Auto on/off headlights

When the ignition switch is in the "ON" position, the headlights, instrument panel illumination, front side marker lights, tail lights and license plate lights are automatically on or off depending on the level of the ambient light.

NOTE

The sensitivity of the auto on/off headlights can be changed by your SUBARU dealer. Contact your SUBARU dealer for details.

▼ **Sensor of the auto on/off headlights**

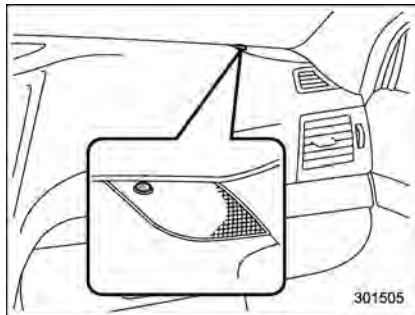

The sensor is on the instrument panel as shown in the illustration.

CAUTION

If any object is placed on or near the sensor, the sensor may not detect the level of the ambient light correctly and the auto on/off headlights may not operate properly.

■ **High/low beam change (dimmer)**

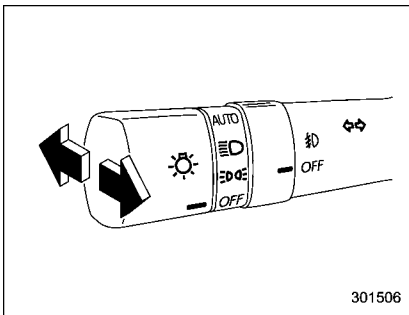

To change from low beam to high beam, push the turn signal lever forward. When the headlights are on high beam, the high beam indicator light "☰●" on the combination meter is also on.

To switch back to low beam, pull the lever back to the detent position.

■ **Headlight flasher**

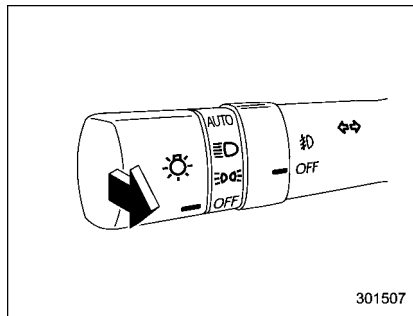

CAUTION

Do not hold the lever in the flashing position for more than just a few seconds.

To flash the headlights, pull the lever toward you and then release it. The high beam will stay on for as long as you hold the lever. The headlight flasher works even though the lighting switch is in the "OFF" position.

When the headlights are on high beam, the high beam indicator light "☰●" on the combination meter also illuminates.

■ Daytime running light system

WARNING

The brightness of the illumination of the high beam headlights is reduced by the daytime running light system. The light switch must always be turned to the “” position when it is dark outside.

The high beam headlights will automatically illuminate at reduced brightness when the engine has started, under the following conditions.

- The parking brake is fully released.
- The light switch is in the “OFF” or “” position.
- The light switch is in the “AUTO” position and the headlights do not turn on automatically.
- The select lever is in a position other than the “P” position (AT and CVT models).

NOTE

- **When the light switch is in the “” position, the front side marker lights, tail lights and license plate lights are illuminated.**
- **After turning on the ignition switch to the “ON” position, even if the**

parking brake is applied, the daytime running lights continue to illuminate until the ignition switch is returned to the “LOCK” position.

Turn signal lever

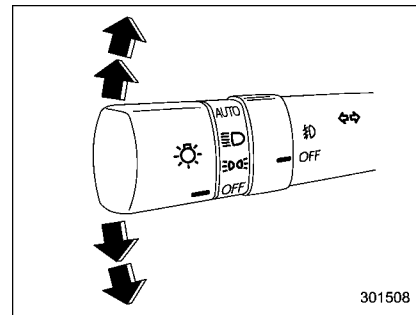



To activate the right turn signal, push the turn signal lever up. To activate the left turn signal, push the turn signal lever down. When the turn is finished, the lever will return automatically. If the lever does not return after cornering, return the lever to the neutral position by hand.

To signal a lane change, push the turn signal lever up or down slightly and hold it during the lane change. The turn signal indicator lights will flash in the direction of the turn or lane change. The lever will return automatically to the neutral position when you release it.

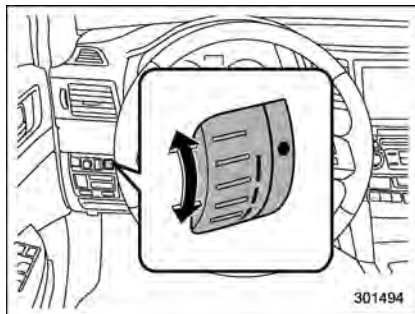
Illumination brightness control



The illumination brightness of the clock display, audio, air conditioner, multi function display and meter/gauge dims under the following conditions.

- when the light switch is in the “” or “” position
- when the light switch is in the “AUTO” position and the headlights illuminate automatically

You can adjust the illumination brightness for better visibility.

To brighten, turn the control dial upward.

To darken, turn the control dial downward.

NOTE

- When the control dial is turned fully upward, the illumination brightness becomes the maximum and the automatic dimming function does not work at all.
- The brightness setting is not canceled even when the ignition switch is turned to the “LOCK” position.

Front fog light switch (if equipped)

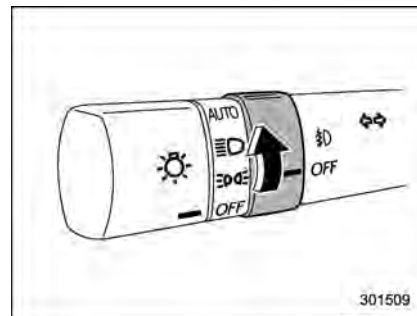

The front fog lights operate under the following conditions.

- when the light switch is in the “” position
- when the light switch is in the “AUTO” position and the headlights turn on automatically

However, the front fog lights turn off when the headlights are switched to high beam.

To turn on the front fog lights, turn the front fog light switch on the turn signal lever upward to the “” position. To turn off the front fog lights, turn the switch back down to the “OFF” position.

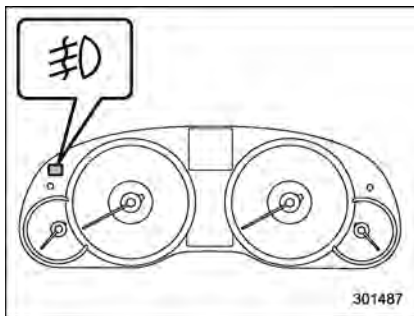

The indicator light located on the combination meter will illuminate when the front fog lights are on.

Wiper and washer

WARNING

In freezing weather, do not use the windshield washer until the windshield is sufficiently warmed by the defroster.

Otherwise the washer fluid can freeze on the windshield, blocking your view.

CAUTION

- Do not operate the washer continuously for more than 10 seconds, or when the washer fluid tank is empty. This may cause overheating of the washer motor. Check the washer fluid level frequently, such as at fuel stops.
- Do not operate the wipers when the windshield or rear window is dry. This may scratch the glass, damage the wiper blades and cause the wiper motor to burn out. Before operating the wiper on a dry windshield or rear window, always use the windshield washer.

- In freezing weather, be sure that the wiper blades are not frozen to the windshield or rear window before switching on the wipers. Attempting to operate the wiper with the blades frozen to the window glass could cause not only the wiper blades to be damaged but also the wiper motor to burn out. If the wiper blades are frozen to the window glass, be sure to operate the defroster, wiper deicer (if equipped) or rear window defogger before turning on the wiper.
- If the wipers stop during operation because of ice or some other obstruction on the window, the wiper motor could burn out even if the wiper switch is turned off. If this occurs, promptly stop the vehicle in a safe place, turn the ignition switch to the "LOCK" position and clean the window glass to allow proper wiper operation.
- Use clean water if windshield washer fluid is unavailable. In areas where water freezes in winter, use SUBARU Windshield Washer Fluid or the equivalent. Refer to "Windshield washer

fluid" 11-42.

Also, when driving the vehicle when there are freezing temperatures, use non-freezing type wiper blades.

- Do not clean the wiper blades with gasoline or a solvent, such as paint thinner or benzine. This will cause deterioration of the wiper blades.

NOTE

- The front wiper motor is protected against overloads by a circuit breaker. If the motor operates continuously under an unusually heavy load, the circuit breaker may trip to stop the motor temporarily. If this happens, park your vehicle in a safe place, turn off the wiper switch, and wait for approximately 10 minutes. The circuit breaker will reset itself, and the wipers will again operate normally.
- Clean your wiper blades and window glass periodically with a washer solution to prevent streaking, and to remove accumulations of road salt or road film. Keep the washer button depressed at least for 1 second so that washer solution will be sprinkled all over the windshield or rear window.

- Grease, wax, insects or other material on the windshield or the wiper blades results in jerky wiper operation and streaking on the glass. If you cannot remove those streaks after operating the washer or if the wiper operation is jerky, clean the outer surface of the windshield or rear window and the wiper blades using a sponge or soft cloth with a neutral detergent or mild-abrasive cleaner. After cleaning, rinse the window glass and wiper blades with clean water. The glass is clean if no beads form on the glass when you rinse with water.

- If you cannot eliminate the streaking even after following this procedure, replace the wiper blades with new ones. For replacement instructions, refer to "Replacement of wiper blades" 11-43.

Windshield wiper and washer switches

The wiper operates only when the ignition switch is in the "ON" position.

Windshield wipers

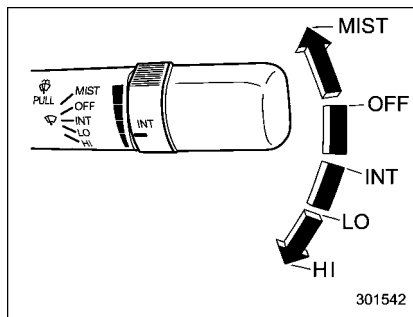

MIST : Mist (for a single wipe)

OFF : Off

INT: Intermittent

LO: Low speed

HI: High speed

To turn the wipers on, push the wiper control lever down.

To turn the wipers off, return the lever to the "OFF" position.

For a single wipe of the wipers, push the lever up. The wipers operate until you release the lever.

▼ Wiper intermittent time control

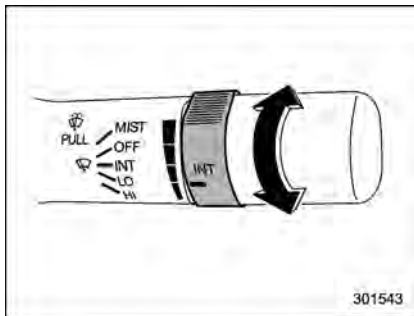

When the wiper switch is in the “INT” position, turn the dial to adjust the operating interval of the wiper. The operating interval can be adjusted in five steps from the shortest interval to the longest.

▼ Windshield washer

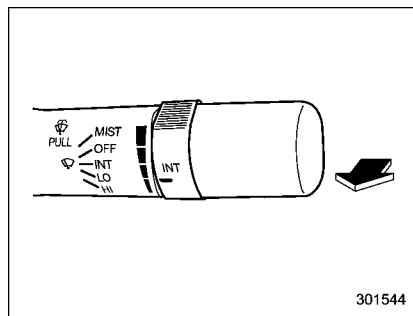

To wash the windshield, pull the wiper control lever toward you. The washer fluid sprays until you release the lever. The wipers operate while you pull the lever.

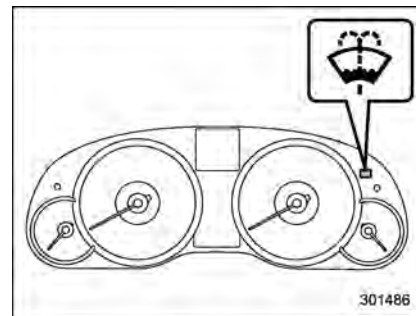

NOTE

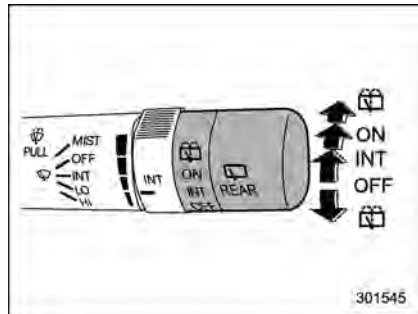

The windshield washer fluid warning light illuminates when the washer fluid level in the tank has dropped to the lower limit. If the warning light illuminates, refill the tank with fluid. For the tank refilling method, refer to “Windshield washer fluid” 11-42.

■ Rear window wiper and washer switch (Outback)



-  Washer (accompanied by wiper operation)
- ON: Continuous
- INT: Intermittent
- OFF: Off
-  Washer (accompanied by wiper operation)

▼ Rear wiper

To turn the rear wiper on, turn the knob on the end of the wiper control lever upward to the “INT” or “ON” position.

To turn the wiper off, return the knob on the end of the lever to the “OFF” position.

With the switch turned to the “INT” position, the rear wiper will operate intermittently at intervals corresponding to the vehicle speed.

When you subsequently move the select

lever to the “R” position (AT and CVT models) or the shift lever to the reverse position (MT models), the rear wiper will switch to continuous operation. When you move the select lever/shift lever from the “R” (reverse) position to another position, the rear wiper will return to intermittent operation.

▼ Washer

To wash the rear window while the rear wiper is operating, turn the knob on the end of the wiper control lever upward to the “” position. The washer fluid sprays until you release the knob.

To wash the rear window when the rear wiper is not in use, turn the knob on the end of the wiper control lever downward to the “” position. The washer fluid sprays and the wiper operates until you release the knob.

Defogger and deicer

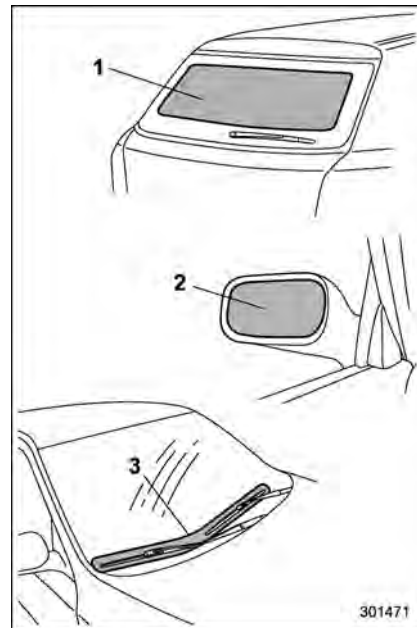

- 1) Rear window defogger
- 2) Outside mirror defogger (if equipped)
- 3) Windshield wiper deicer (if equipped)

The vehicle is equipped with a rear

window defogger. Some models are also equipped with an outside mirror defogger and/or windshield wiper deicer. The defogger and deicer system is activated only when the ignition switch is in the "ON" position.

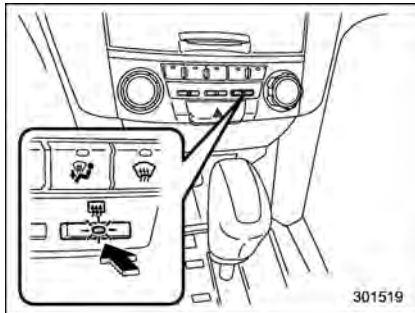

Manual climate control system

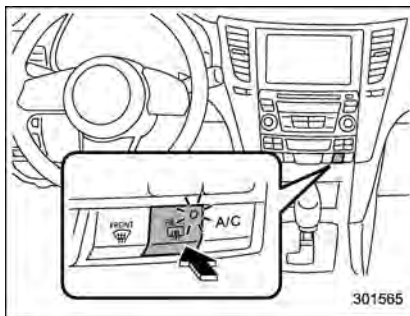

Automatic climate control system

To activate the defogger and deicer system, press the control switch that is located on the climate control panel. The rear window defogger, outside mirror defogger and windshield wiper deicer are activated simultaneously. The indicator light on the control switch illuminates while the defogger and deicer system is activated.

To turn them off, press the control switch again. They also turn off when the ignition switch is turned to the "Acc" or "LOCK" position.

The defogger and deicer system will automatically shut off after approximately 15 minutes. If the rear window and outside mirror have been cleared and the windshield wiper blades have been deiced

completely before that time, press the control switch to turn them off. If defrosting, defogging or deicing is not complete, you have to press the control switch to turn them on again.

The defogger and deicer system setting can be changed for continuous operation by a SUBARU dealer. Contact your SUBARU dealer for details.

If the battery voltage drops below the permissible level, continuous operation of the defogger and deicer system is canceled and the system stops operating.



CAUTION

- **To prevent the battery from being discharged, do not operate the defogger and deicer system continuously for any longer than necessary.**
- **Do not use sharp instruments or window cleaner containing abrasives to clean the inner surface of the rear window. They may damage the conductors printed on the window.**

NOTE

- Turn on the defogger and deicer system if the wipers are frozen to the windshield.
- If the windshield is covered with snow, remove the snow so that the windshield wiper deicer works effectively.
- While the defogger and deicer system is in the continuous operation mode, if the vehicle speed remains at 9 mph (15 km/h) or lower for 15 minutes, the windshield wiper deicer automatically stops operating, though the rear window defogger and outside mirror defogger maintain continuous operation in this condition.

Mirrors

Always check that the inside and outside mirrors are properly adjusted before you start driving.

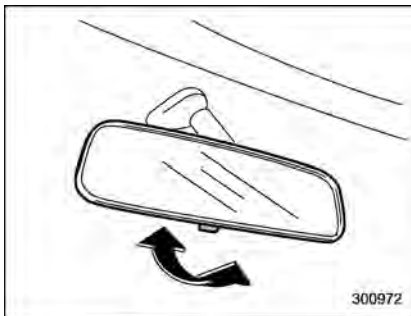
■ Inside mirror

The inside mirror has a day and night position. Pull the tab at the bottom of the mirror toward you for the night position. Push it away for the day position. The night position reduces glare from headlights.

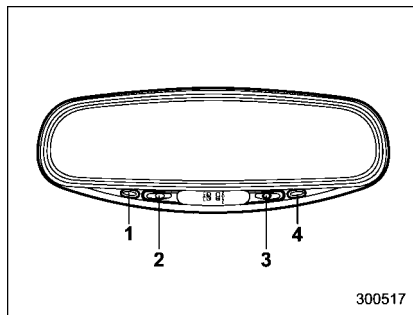
■ Auto-dimming mirror/compass (if equipped)

- 1) Left button
- 2) Auto dimming indicator
- 3) Photosensor
- 4) Right button

The auto-dimming mirror/compass has an anti-glare feature which automatically reduces glare coming from headlights of vehicles behind you. It also contains a built-in compass.

- By pressing and releasing the left button, the automatic dimming function is toggled on or off. When the automatic dimming function is on, the auto dimming indicator light (green) located to the right of the button will illuminate.
- By pressing and releasing the right

button, the compass display is toggled on or off. When the compass is on, an illuminated compass reading will appear in the lower part of the mirror.

Even with the mirror in anti-glare mode, the mirror surface turns bright if the transmission is shifted into reverse. This is to ensure good rearward visibility during reversing.

▼ Photosensors

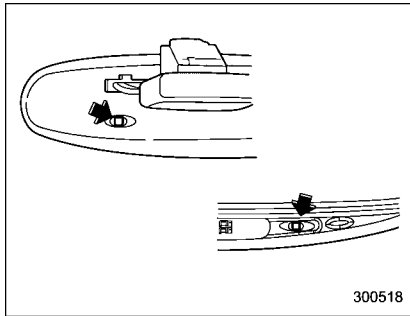

The mirror has a photosensor attached on both the front and back sides. If the glare from the headlights of vehicles behind you strikes the mirror, these sensors detect it and make the reflection surface of the mirror dimmer to help prevent you from being blinded. For this reason, use care not to cover the sensors with stickers, or

other similar items. Periodically wipe the sensors clean using a piece of dry soft cotton cloth or an applicator.

▼ Compass calibration

1. For optimum calibration, switch off all nonessential electrical accessories (rear window defogger, heater/air conditioning system, spotlight, etc.) and ensure all doors are shut.
2. Drive to an open, level area away from large metallic objects or structures and make certain the ignition switch is in the "ON" position.
3. Press and hold the left button for 3 seconds then release, and the compass will enter the calibration mode. "CAL" and direction will be displayed.
4. Drive slowly in a circle until "CAL" disappears from the display (approximately two or three circles). The compass is now calibrated.
5. Further calibration may be necessary should outside influences cause the mirror to read inaccurately. You will know that this has occurred if your compass begins to read in only limited directions. Should you encounter this situation, return to step one of the above procedure and recalibrate the mirror.

▼ Compass zone adjustment

1. The zone setting is factory preset to Zone 8. Refer to the "Compass calibration zone" map attached to the end of this manual to verify that the compass zone setting is correct for your geographical location.
2. Press and hold the right button for 3 seconds then release, and the word "ZONE" will briefly appear and then the zone number will be displayed.
3. Press the right-hand button repeatedly to cycle the display through all possible zone settings. Stop cycling when the correct zone setting for your location is displayed.
4. Releasing the button for 3 seconds will exit the zone setting mode.

■ **Outside mirrors**

▼ **Convex mirror (passenger side)**

WARNING

Objects look smaller in a convex mirror and farther away than when viewed in a flat mirror. Do not use the convex mirror to judge the distance of vehicles behind you when changing lanes. Use the inside mirror (or glance backwards) to determine the actual size and distance of objects that you view in convex mirror.

▼ **Remote control mirror switch**

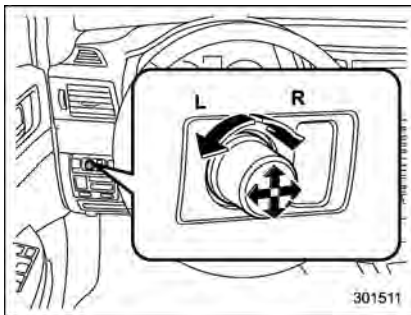

The remote control mirrors operate only when the ignition switch is in the "ON" or "Acc" position.

1. Turn the knob to the "L" side to adjust the left-hand mirror or to the "R" side to adjust the right-hand mirror.
2. Move the knob in the direction you want to move the mirror.
3. Return the knob to the neutral position to prevent unintentional operation.

The mirrors can also be adjusted manually.

Tilt/telescopic steering wheel

WARNING

Do not adjust the steering wheel tilt/telescopic position while driving. This may cause loss of vehicle control and result in personal injury.

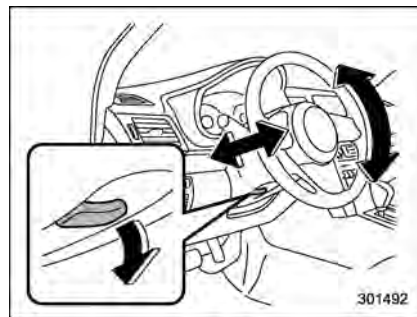

1. Adjust the seat position. Refer to "Front seats" ¶ 1-2.
2. Pull the tilt/telescopic lock lever down.
3. Move the steering wheel to the desired level.
4. Pull the lever up to lock the steering wheel in place.
5. Make sure that the steering wheel is securely locked by moving it up and down,

and forward and backward.

Horn

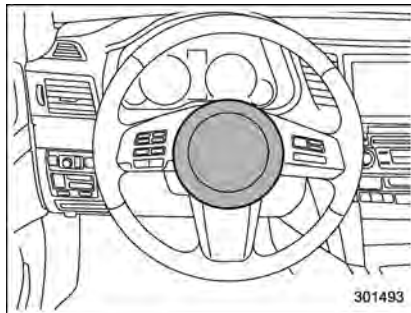

To sound the horn, push the horn pad.

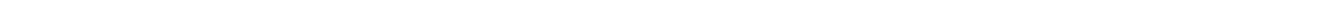
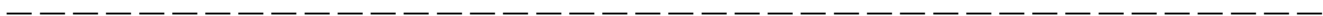
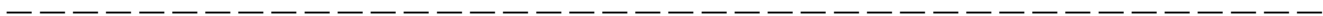

| | | | |
|---|------|---|------|
| Ventilator | 4-2 | Efficient cooling after parking in direct sunlight | 4-14 |
| Air flow selection | 4-2 | Lubrication oil circulation in the refrigerant circuit | 4-14 |
| Ventilators..... | 4-3 | Checking air conditioning system before summer season | 4-14 |
| Manual climate control system (if equipped) | 4-4 | Cooling and dehumidifying in high humidity and low temperature weather condition | 4-14 |
| Control panel | 4-4 | Air conditioner compressor shut-off when engine is heavily loaded | 4-14 |
| Heater operation | 4-6 | Refrigerant for your climate control system | 4-14 |
| Air conditioner operation..... | 4-7 | Air filtration system | 4-15 |
| Automatic climate control system (if equipped) | 4-8 | Replacing an air filter..... | 4-15 |
| Control panel | 4-9 | | |
| Temperature sensors..... | 4-13 | | |
| Operating tips for heater and air conditioner | 4-14 | | |
| Cleaning ventilator grille..... | 4-14 | | |

Ventilator

■ Air flow selection

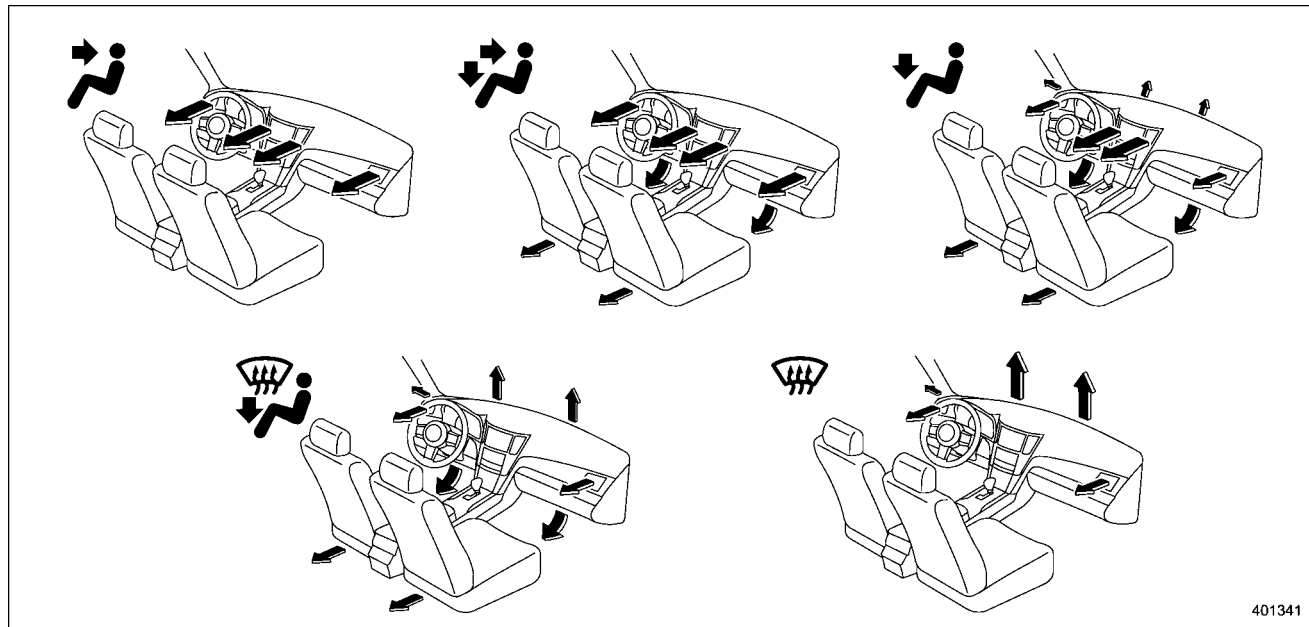

■ Ventilators

▼ Center ventilators

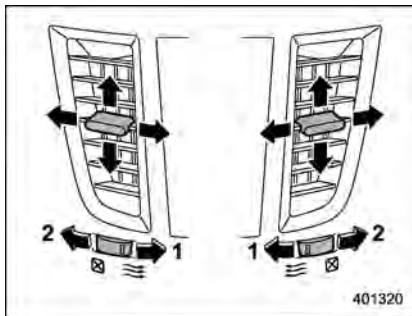

- 1) Open
- 2) Close

Move the tab up and down or right and left to adjust the flow direction.

To open the ventilator, turn the center grille open/close wheel to the "≡" position.

To close it, turn the wheel to the "☒" position.

▼ Side ventilators

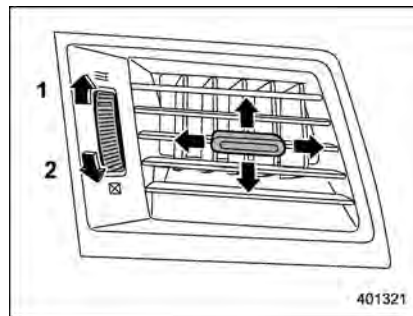

- 1) Open
- 2) Close

Move the tab up and down or right and left to adjust the flow direction.

To open the ventilator, turn the side grille open/close wheel upward to the "≡" position.

To close it, turn the wheel downward to the "☒" position.

Manual climate control system (if equipped)

■ Control panel

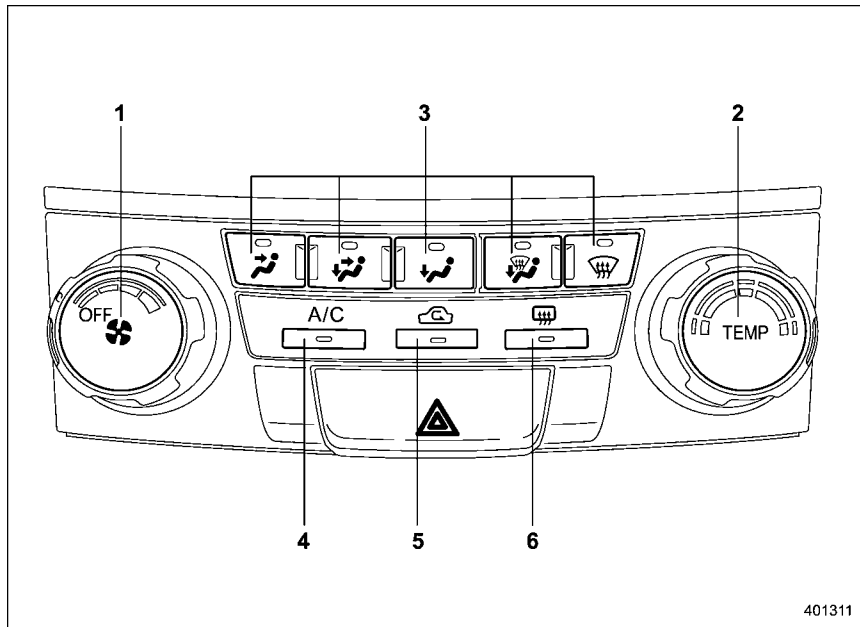

- 1) Fan speed control dial
- 2) Temperature control dial
- 3) Air flow control buttons
- 4) Air conditioner button
- 5) Air inlet selection button
- 6) Rear window defogger button (Refer to "Defogger and deicer" 3-34.)

▼ Fan speed control dial

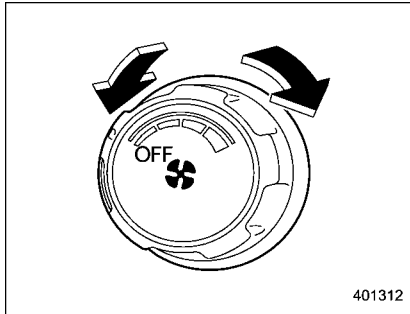

401312

The fan operates only when the ignition switch is turned to the "ON" position. The fan speed control dial is used to select four fan speeds.

▼ Temperature control dial

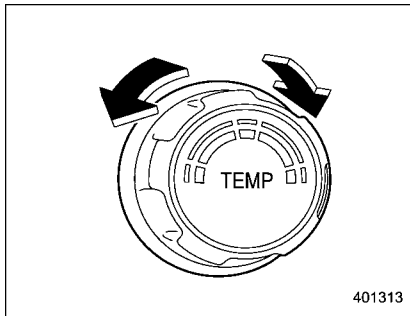

401313

This dial regulates the temperature of air flow from the air outlets over a range from the blue side (cool) to red side (warm).

▼ Air flow control buttons

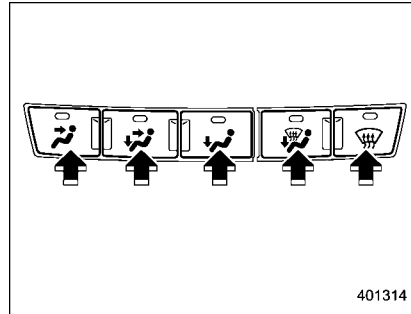



401314

The air flow control buttons consist of the following five buttons:

: Air flows through the instrument panel outlets.



: Air flows through the instrument panel outlets and the foot outlets.

: Air flows through the instrument panel outlets, the foot outlets, and some through the windshield defroster outlets.

: Air flows through the instrument panel outlets, the windshield defroster outlets, and the foot outlets.

: Air flows through the instrument panel outlets and the windshield defroster outlets.

NOTE

When the  button or  button is pressed the air conditioner compressor automatically operates to quickly defog the windshield. However the indicator on the air conditioner button will not illuminate. At the same time, the air inlet selection is automatically set to "outside air" mode.

▼ Air conditioner button

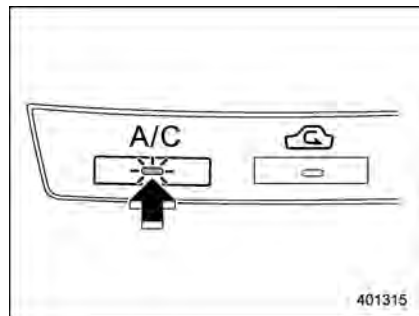

The air conditioner operates only when the engine is running.

Press the air conditioner button while the fan is in operation to turn on the air conditioner. The indicator light will illuminate.

Press it again to turn off the air conditioner.

▼ Air inlet selection button

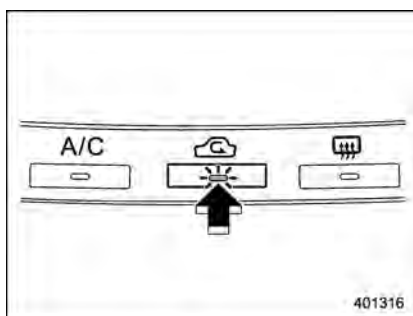

ON position (recirculation): Interior air is recirculated inside the vehicle.

Press the air inlet button to the ON position. The indicator light will illuminate. Place this button in the ON position when you wish to cool the cabin quickly or are driving on a dusty road.



OFF position (outside air): Outside air is drawn into the passenger compartment. Press the air inlet button again to the OFF position. The indicator light will turn off.

Place this button in the OFF position when you reach a road that is not dusty and when you wish to achieve a comfortable temperature in the cabin.

WARNING

Continued operation in the ON position may fog up the windows. Switch to the OFF position as soon as the outside dusty condition clears.

Heater operation
NOTE

- When the “” button or “” button is pressed the air conditioner compressor automatically operates to quickly defog the windshield. However the indicator on the air conditioner button will not illuminate. At the same time, the air inlet selection is automatically set to “outside air” mode.

- Warm air also comes out from the right and left air outlets. To stop warm air flow from these outlets, turn the corresponding wheel to the “” position.

▼ Defrosting or defogging the windshield

To direct warm air to the windshield and front door windows:

1. Set the air inlet selection button to the OFF position.
2. Press the “” button.

3. Turn the temperature control dial all the way to the right.
4. Set the fan speed control dial to the highest speed.

▼ Heating and defrosting

To direct warm air toward the floor and the windshield:

1. Set the air inlet selection button to the OFF position.
2. Press the “” button.
3. Set the temperature control dial to the most comfortable level.
4. Set the fan speed control dial to the desired speed.

▼ Heating

To direct warm air toward the floor:

1. Set the air inlet selection button to the OFF position.
2. Press the “” button.
3. Set the temperature control dial to the most comfortable level.
4. Set the fan speed control dial to the desired speed.

▼ Bi-level heating

This setting allows you to direct air of different temperatures from the instrument panel and foot outlets. The air from the

foot outlets is slightly warmer than from the instrument panel outlets.

1. Set the air inlet selection button to the OFF position.
2. Press the “” button.
3. Set the temperature control dial to the desired temperature level.
4. Set the fan speed control dial to the desired speed.

Setting the temperature control dial fully turned to the red area or blue area decreases the temperature difference between the air from the instrument panel outlets and the air from the foot outlets.

▼ Ventilation

To force outside air through the instrument panel outlets:

1. Set the air inlet selection button to the OFF position.
2. Press the “” button.
3. Set the temperature control dial all the way left.
4. Set the fan speed control dial to the desired speed.

When driving on a dusty road, set the air inlet control button to the ON position.



WARNING

Continued operation in the ON position may fog up the windows. Switch to the OFF position as soon as the outside dusty condition clears.

■ Air conditioner operation

▼ Cooling or dehumidifying

For cooling and dehumidification of the passenger compartment, air flows through the instrument panel outlets:



1. Set the air inlet selection button to the OFF position.
2. Press the “” button.
3. Set the air conditioner button to the “ON” position.
4. Set the temperature control dial to the blue side.
5. Set the fan speed control dial at the desired speed.

▼ Defrosting or defogging

To direct warm air to the windshield and front door windows:

1. Press the “” button.
2. Set the temperature control dial to the red side.
3. Set the fan speed control dial at the highest speed.

NOTE

When the “” button or “” button is pressed the air conditioner compressor automatically operates to quickly defog the windshield. However the indicator on the air conditioner button will not illuminate. At the same time, the air inlet selection is automatically set to “outside air” mode.

Automatic climate control system (if equipped)

NOTE

- Operate the automatic climate control system when the engine is running.
- The blower fan rotates at a low speed when the engine coolant temperature is low.

For efficient defogging or dehumidifying in cold weather, press the “A/C” button.

- Even when cooling is not necessary, setting the temperature much lower than the current outlet air temperature turns on the air conditioner compressor automatically and the “A/C” indicator light on the control panel illuminates.

The automatic climate control system automatically controls outlet air temperature, fan speed, air flow distribution air-inlet control, and air conditioner compressor operation. It activates when the fan speed control button or the “AUTO” button is pressed, and is used to maintain a constant, comfortable climate within the passenger compartment. If you press the defroster button while the automatic climate control system is deactivated, only the defroster function will be activated.

The temperature can be set within a range of 61 to 89°F (18.5 to 31.5°C).

■ Control panel

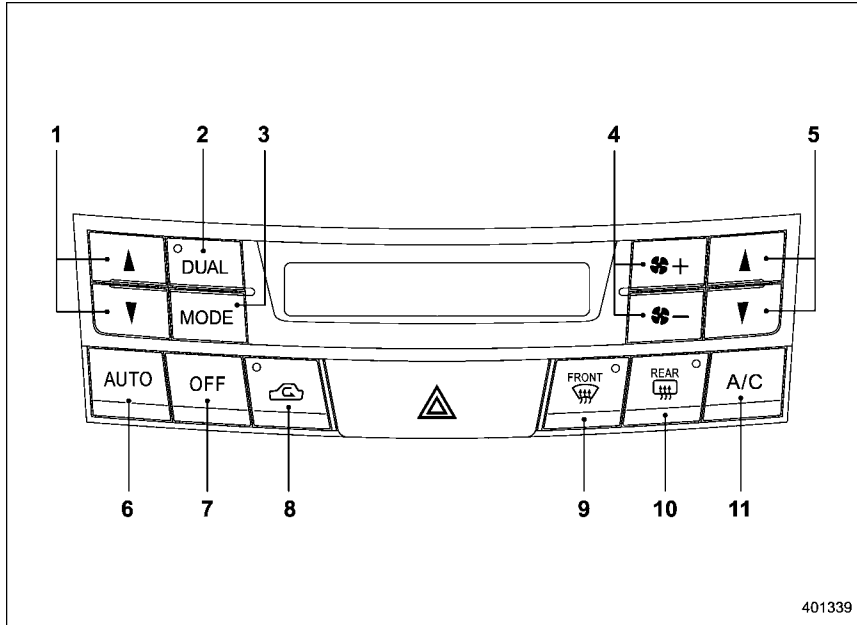

- 1) Temperature control button (driver's side)
- 2) Dual mode button
- 3) Air flow mode selection button
- 4) Fan speed control button
- 5) Temperature control button (front passenger's side)
- 6) AUTO button
- 7) OFF button
- 8) Air inlet selection button
- 9) Defroster button
- 10) Rear window defogger button (Refer to "Defogger and deicer" 3-34.)
- 11) Air conditioner button

▼ **AUTO button**

FULL AUTO mode operation:

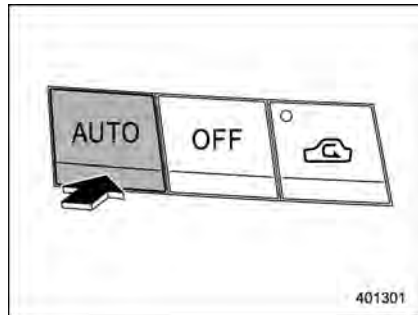

When the "AUTO" button is pressed, the indicator light "FULL AUTO" on the display illuminates. In this state, fan speed, air flow distribution, air-inlet control, and air conditioner compressor operation are automatically controlled.

AUTO mode operation:

If you operate any of the buttons on the control panel other than the "OFF" button, rear window defogger button and temperature control buttons during FULL AUTO mode operation, the indicator light "FULL" on the control panel will turn off and the indicator light "AUTO" will remain illuminated. You can then manually control the system as desired using the button

you operated. To change the system back to the FULL AUTO mode, press the "AUTO" button.

▼ **OFF button**

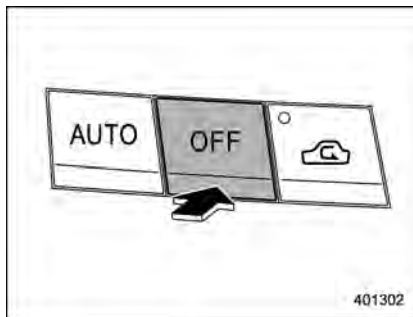

The automatic climate control system turns off (the air conditioner compressor and fan turn off) when the "OFF" button is pressed.

When the "OFF" button is pressed, the outside air circulation mode (air inlet selection OFF) is automatically selected.

▼ **Temperature control button**

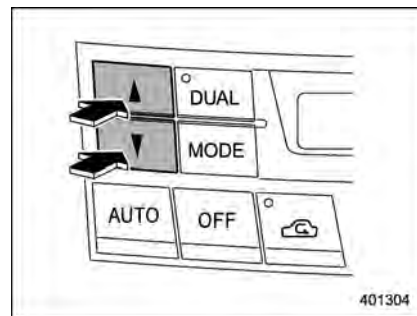

Driver's side

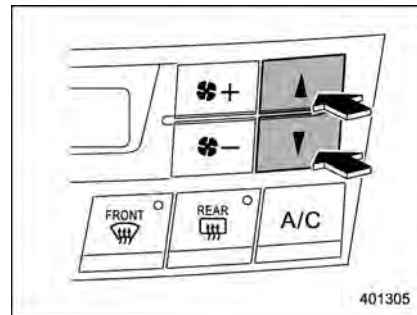

Passenger's side

To increase the temperature setting, press the "▲" side of the temperature control

button. To decrease the temperature setting, press the ▼ side of the temperature control button.

Each temperature setting is shown on the display. When the "LO" is shown, the system provides maximum cooling performance. When the "HI" is shown, the system provides maximum heating performance.

▼ DUAL mode

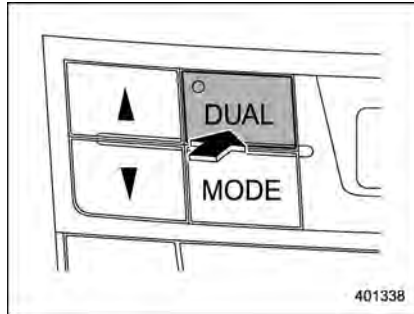

It is possible to make separate temperature settings for the driver's side and passenger's side (DUAL mode).

To activate the DUAL mode:



Press the "DUAL" button. When the DUAL mode is activated, the indicator light on the "DUAL" button illuminates.

To deactivate the DUAL mode:

Press the "DUAL" button again. When the DUAL mode is deactivated, the indicator light on the "DUAL" button turns off and the temperature setting for the front passenger's side becomes the same as the setting for the driver's side.

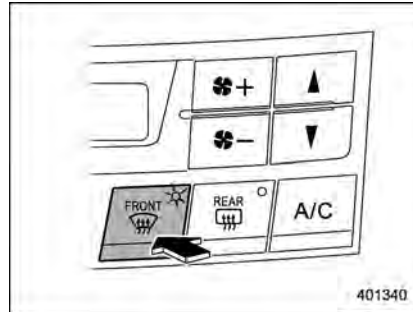
▼ – Defroster button



To defrost or dehumidify the windshield and front door windows, press the defroster button "". When the "" button is pressed, the air conditioner compressor automatically operates to quickly defog the windshield, outside air is drawn into the passenger compartment, air flow is directed towards the windshield and front door windows, and the indicator light on the button illuminates.

After eliminating the fogging from the windshield, return the climate control system to the FULL AUTO mode by pressing the "AUTO" button or turn off by pressing the "OFF" button.

Alternatively, press the "" button again to return the system to the setting that was selected before you activated the defroster.

▼ Fan speed control button

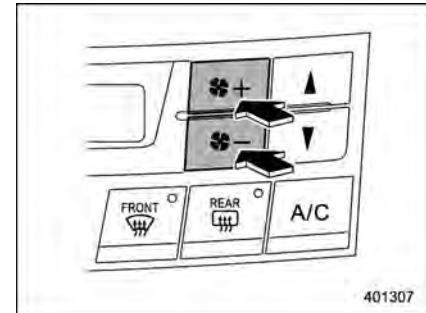

The fan speed control button has 6 different fan speed positions.

The fan speed is shown by the display.

▼ A/C – Air conditioner button

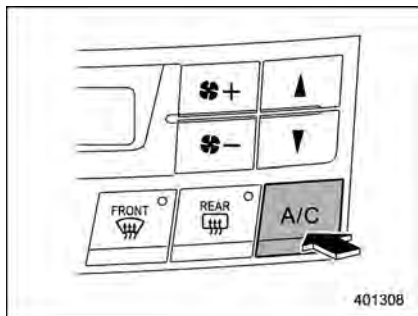

If the windshield starts to fog when the climate control system is operated in the AUTO mode, press the air conditioner button “A/C” to defog and dehumidify.

When this button is pressed, the air conditioner compressor turns on and the indicator light “A/C” on the display illuminates. To turn off the air conditioner compressor, press the “A/C” button again.

NOTE

The air conditioner compressor does not operate when the outside air temperature is below 32°F (0°C).

▼ Air flow mode selection button

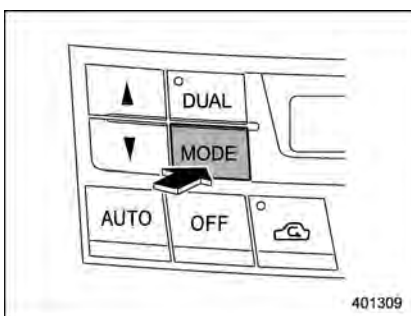

Select the desired air flow mode by pressing the air flow mode selection button. The selected air flow mode is shown on the display.

☞ (Ventilation): Air flows through the instrument panel outlets.

☞ (Bi-level): Air flows through the instrument panel outlets and the foot outlets.

☞ (Heat): Air flows through the instrument panel outlets, the foot outlets, and some through the windshield defroster outlets.

☞ (Heat-def): Air flows through the instrument panel outlets, the windshield defroster outlets, and the foot outlets.

NOTE

When the “☞” mode is selected, the air conditioner compressor automatically operates to quickly defog the windshield and the air inlet selection is automatically set to the “outside air” mode.

▼ Air inlet selection button

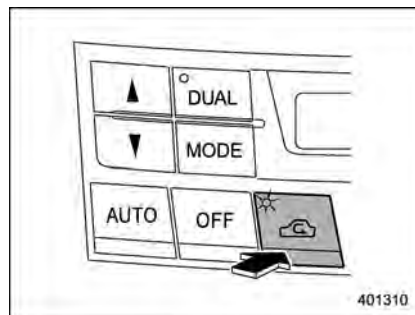

Select air flow by pressing the air inlet selection button “☞”.

ON position (recirculation): Interior air is recirculated inside the vehicle. Press the air inlet selection button to the ON position for fast cooling with the air conditioner or when driving on a dusty road. The indicator light will illuminate.

OFF position (outside Air): Outside air is drawn into the passenger compartment.

Press the air inlet selection button to the OFF position when the interior has cooled to a comfortable temperature and the road is no longer dusty. The indicator light will turn off.

WARNING

Continued operation in the ON position (recirculation) may fog up the windows. Switch to the OFF position (outside air) as soon as the outside dusty condition clears.

NOTE

When driving on a dusty road or behind a vehicle that emits unpleasant exhaust gases, set the air inlet selection button to the ON position (recirculation).

From time to time, return the air inlet selection button to the OFF position (outside air) to draw outside air into the passenger compartment.

Temperature sensors

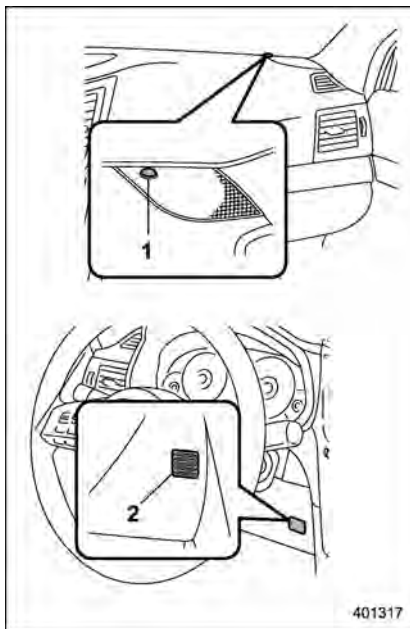

- 1) Solar sensor
- 2) Interior air temperature sensor

The automatic climate control system employs several sensors. These sensors are delicate. If they are treated incorrectly

and become damaged, the system may not be able to control the interior temperature correctly. To avoid damaging the sensors, observe the following precautions:

- Do not subject the sensors to impact.
- Keep water away from the sensors.
- Do not cover the sensors.

The sensors are located as follows:

- Solar sensor: beside windshield defroster grille
- Interior air temperature sensor: on the side of the driver-side part of the center panel
- Outside temperature sensor: behind front grille.

Operating tips for heater and air conditioner

■ Cleaning ventilator grille

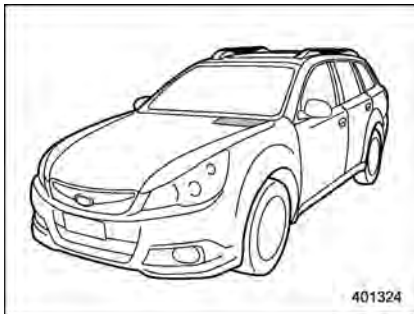

Always keep the front ventilator inlet grille free of snow, leaves, or other obstructions to ensure efficient heating and defrosting. Since the condenser is located in front of the radiator, this area should be kept clean because cooling performance is impaired by any accumulation of insects and leaves on the condenser.

■ Efficient cooling after parking in direct sunlight

After parking in direct sunlight, drive with the windows open for a few minutes to allow outside air to circulate into the

heated interior. This results in quicker cooling by the air conditioner. Keep the windows closed during the operation of the air conditioner for maximum cooling efficiency.

■ Lubrication oil circulation in the refrigerant circuit

Operate the air conditioner compressor at a low engine speed (at idle or low driving speeds) a few minutes each month during the off-season to circulate its oil.

■ Checking air conditioning system before summer season

Check the air conditioner unit for refrigerant leaks, hose conditions, and proper operation each spring. Have the air conditioning system checked by your SUBARU dealer.

■ Cooling and dehumidifying in high humidity and low temperature weather condition

Under certain weather conditions (high relative humidity, low temperatures, etc.) a small amount of water vapor emission from the air outlets may be noticed. This condition is normal and does not indicate any problem with the air conditioning

system.

■ Air conditioner compressor shut-off when engine is heavily loaded

To improve acceleration and gas mileage, the air conditioner compressor is designed to temporarily shut off during air conditioner operation whenever the accelerator is fully depressed such as during rapid acceleration or when driving on a steep upgrade.

■ Refrigerant for your climate control system

Your air conditioner uses ozone friendly refrigerant HFC134a. Therefore, the method of adding, changing or checking the refrigerant is different from the method for CFC12 (freon). Consult your SUBARU dealer for service. Repairs needed as a result of using the wrong refrigerant are not covered under warranty.

Air filtration system

Your vehicle's air conditioning system is equipped with an air filtration system. Replace the air filter element according to the replacement schedule shown in the following table. This schedule should be followed to maintain the filter's dust collection ability. Under extremely dusty conditions, the filter should be replaced more frequently. Have your filter checked or replaced by your SUBARU dealer. For replacement, use only a genuine SUBARU air filter kit.

Replacement schedule:

Every 15 months or 15,000 miles (24,000 km) whichever comes first

CAUTION

Contact your SUBARU dealer if the following occurs, even if it is not yet time to change the filter.

- Reduction of the air flow through the vents.
- Windshield gets easily fogged or misted.

NOTE

The filter can influence the air conditioning, heating and defroster performance if not properly maintained.

■ Replacing an air filter

1. Remove the glove box.
 - (1) Open the glove box.

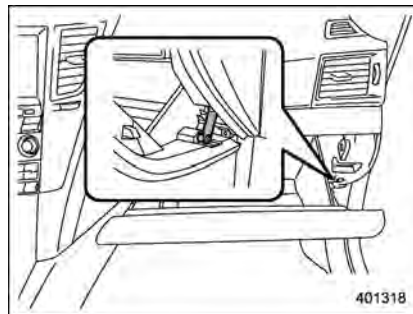

- (2) Remove the damper shaft from the glove box.

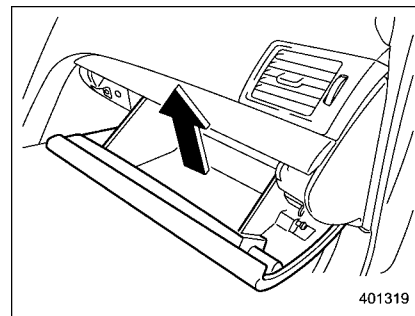

- (3) Pull out the glove box.

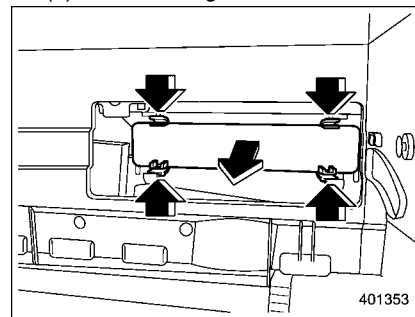

2. Remove the cover of the air filter.

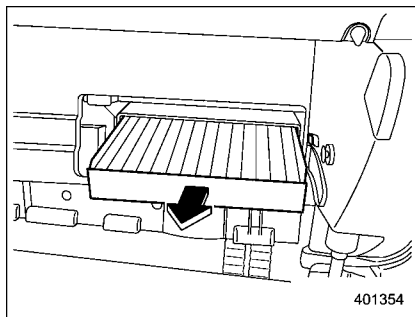

3. Remove the air filter.

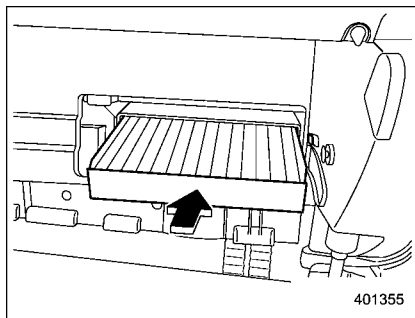

4. Replace the air filter element with a new one.

5. Reinstall the cover of the air filter.

CAUTION

The arrow mark on the filter must point UP.

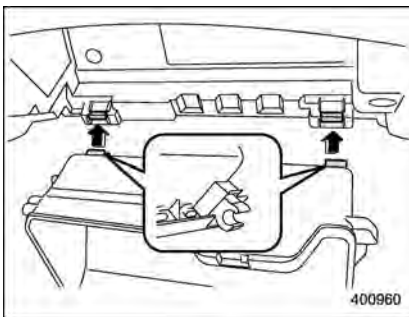

6. Reinstall the glove box, and connect the damper shaft.

7. Close the glove box.

8. LABEL installation

(1) Fill out the information on the service label (small).

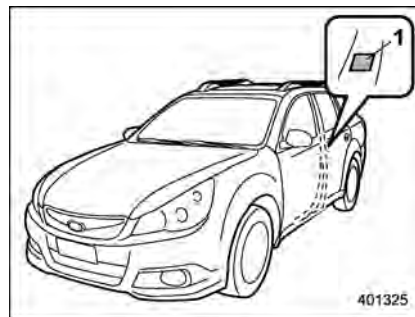

1) Service label

(2) Attach the service label to the driver's side door pillar.

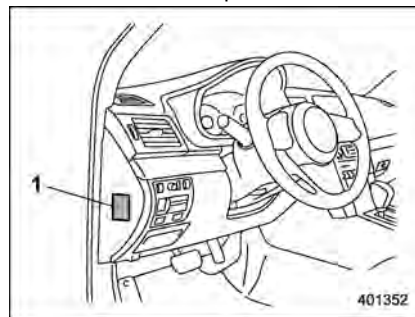

1) Caution label

(3) Attach the caution label on the

driver's side of the instrument panel as shown in the illustration.



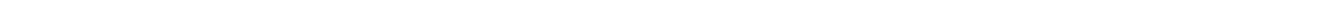
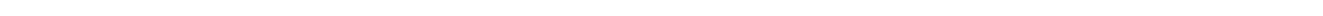
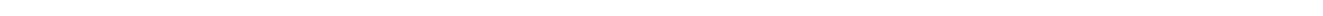
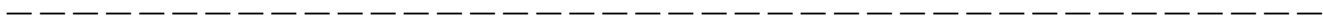
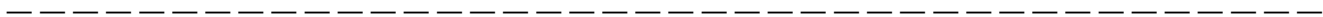

| | | | |
|--|------|--|------|
| Antenna system | 5-2 | CD player operation | 5-18 |
| Printed antenna..... | 5-2 | How to insert a CD (type A)..... | 5-18 |
| FM reception..... | 5-2 | How to insert a CD(s) (type B)..... | 5-18 |
| XM™ satellite radio reception (if equipped) | 5-2 | How to play back a CD | 5-20 |
| Installation of accessories | 5-4 | To select a track from its beginning..... | 5-21 |
| Audio set | 5-4 | Fast-forwarding and fast-reversing | 5-22 |
| Type A audio set (if equipped) | 5-5 | Repeating..... | 5-22 |
| Type B audio set (if equipped) | 5-6 | Random playback | 5-23 |
| Power and sound controls | 5-7 | Scan | 5-24 |
| Power switch and volume control | 5-7 | Display selection | 5-25 |
| Sound control | 5-7 | Folder selection..... | 5-25 |
| Adjustable level of each mode..... | 5-9 | How to eject a CD from the player (type A) | 5-26 |
| FM/AM radio operation | 5-10 | How to eject CDs from the player (type B)..... | 5-26 |
| FM selection | 5-10 | When the following messages are displayed..... | 5-27 |
| AM selection | 5-10 | AUX unit operation | 5-28 |
| Tuning | 5-10 | Precautions to observe when handling a | |
| RDS text display | 5-12 | compact disc..... | 5-29 |
| Station preset | 5-13 | Audio control buttons (if equipped) | 5-30 |
| Satellite radio operation (if equipped) | 5-14 | MODE button | 5-31 |
| XM™ satellite radio | 5-14 | “^” and “v” switch | 5-31 |
| Sirius satellite radio | 5-14 | Volume control switch | 5-31 |
| Satellite radio reception..... | 5-15 | MUTE button (if equipped) | 5-32 |
| Displaying satellite radio ID of tuner | 5-15 | Hands-free system (if equipped) | 5-32 |
| Band selection | 5-15 | Tips for the Hands-free system | 5-32 |
| Channel and category selection..... | 5-15 | Certification for the Hands-free system..... | 5-33 |
| Channel preset..... | 5-17 | Safety precautions..... | 5-33 |
| Display selection..... | 5-18 | Using the Hands-free system | 5-34 |

Antenna system

■ Printed antenna



CAUTION

Do not use sharp instruments or window cleaner containing abrasives to clean the inner surface of the window on which the antenna is printed. Doing so may damage the antenna printed on the window.

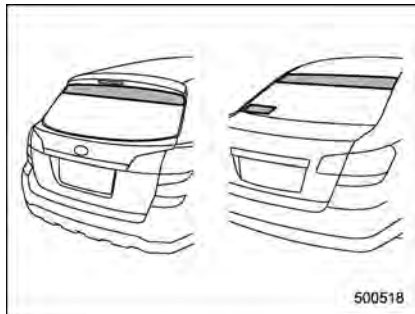

The antenna is printed on the inner surface of the rear window glass.

■ FM reception

Although FM is normally static free, reception can be affected by the surrounding area, atmospheric conditions, station strength and transmitter distance. Buildings or other obstructions may cause momentary static, flutter or station interference. If reception continues to be unsatisfactory, switch to a stronger station.

XM™ satellite radio reception (if equipped)

XM™ is a continental U.S. based satellite radio service including music, news, sports, talk and children's programming. XM™ provides digital quality audio and text information, including song title and artist name. A service fee is required to receive the XM™ service. For more information, contact XM™ at www.xmradio.com or call 1-800-XMRADIO (1-800-967-2346) for U.S. www.xmradio.ca or call 1-877-GET-XMSR (1-877-438-9677) for Canada.

The XM™ satellite radio receiver that is fitted to your vehicle receives the necessary signals from two specially designated satellites that are in a geostationary orbit over the equator. One satellite covers the east coast and the other covers the west coast. Both of them direct their signals north. These signals are then relayed throughout the USA by a network of ground repeater stations. The satellite radio signals are transmitted as "line of sight" signals. Line of sight signals can be blocked by objects such as buildings, but the network of repeater stations allows signal coverage within urban areas such as cities.

You may experience problems in receiving XM™ satellite radio signals in the following situations.

- If you are driving northward in a coastal area

You will notice that the XM™ satellite radio antenna is fixed to the upper right hand corner of your windshield.

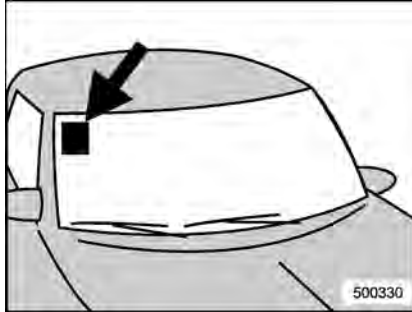

The signal comes from the south and may not be able to reach the antenna in some circumstances when you are driving north.

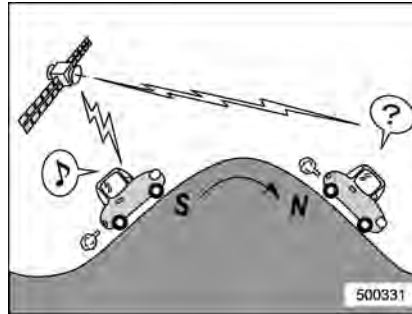

- If you are driving in a tunnel or a covered parking area
- If you are driving beneath the top level of a multi-level freeway
- If you drive under a bridge
- If you are driving next to a tall vehicle (such as a truck or a bus) that blocks the signal
- If you are driving in a valley where the surrounding hills or peaks block the signal from the south
- If you are driving on a mountain road where the southern direction is blocked by mountains



- If you are driving in an area with tall trees that block the signal (10 m or more), for example on a road that goes through a dense forest
- The signal can become weak in some areas that are not covered by the repeater station network.

Please note that these may be other unforeseen circumstances when there are problems with the reception of XM™ satellite radio signals.

Installation of accessories

Always consult your SUBARU dealer before installing a citizen band radio or other transmitting device in your vehicle. Such devices may cause the electronic control system to malfunction if they are incorrectly installed or if they are not suited for the vehicle.

Audio set

Your SUBARU may be equipped with one of the following audio sets. See the pages indicated in this section for operating details.

NOTE

If a cell phone is placed near the audio set, it may cause the audio set to emit noise when the phone receives calls. This noise does not indicate an audio set malfunction. Note that a cell phone should be placed as far as possible from the audio set.

■ Type A audio set (if equipped)

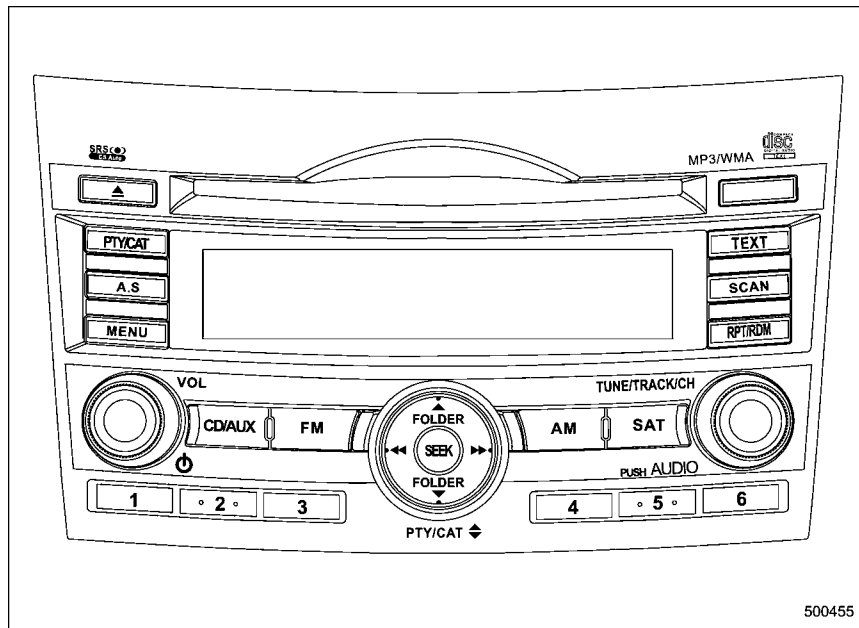

The audio set will operate only when the ignition switch is in the "Acc" or "ON" position.

- Power and sound controls: refer to page 5-7
- Radio operation: refer to page 5-10
- Satellite radio operation (if equipped): refer to page 5-14
- CD (compact disc) player operation: refer to page 5-18
- AUX unit operation: refer to page 5-28

■ Type B audio set (if equipped)

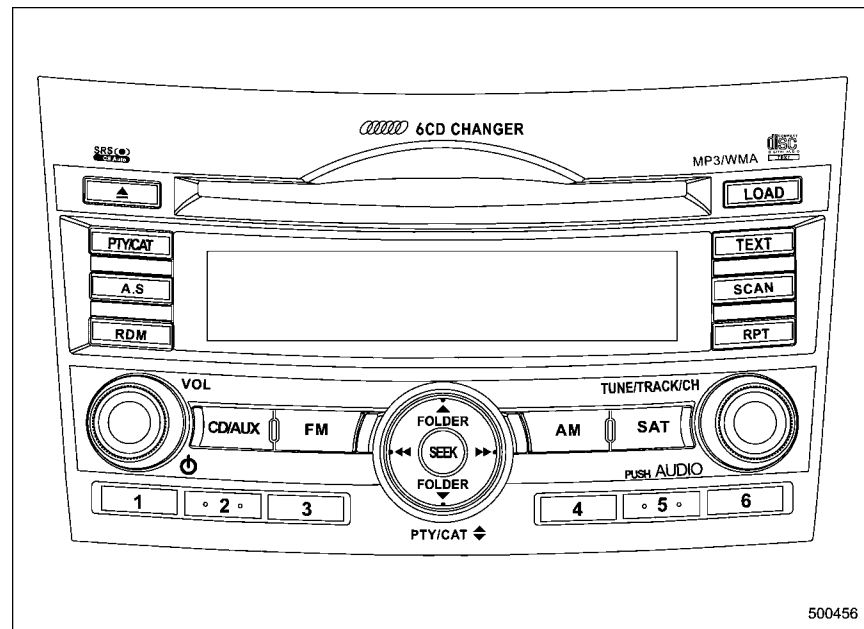

500456

The audio set will operate only when the ignition switch is in the "Acc" or "ON" position.

- Power and sound controls: refer to page 5-7
- Radio operation: refer to page 5-10
- Satellite radio operation (if equipped): refer to page 5-14
- CD (compact disc) player operation: refer to page 5-18
- AUX unit operation: refer to page 5-28

▽ SVC setting

SVC (Speed Volume Control) is a function that automatically adjusts the volume according to the vehicle speed. As the vehicle speed increases, the audio volume automatically increases to match the vehicle speed, in order to create a pleasant listening environment even as the driving noise increases. The amount of this automatic volume change can be set in the range from OFF to 2. The initial setting is OFF.

▽ SRS CS Auto™ setting (type A audio)

SRS CS Auto™ can be set in the range from OFF to 2. When this setting is ON (1 or 2), “” is displayed on the screen.

NOTE

SRS CS Auto™ creates a 5.1ch equivalent surround field using 4 speakers that are installed in the vehicle.

SRS CS Auto™ features:

- 1) Sound originating from door mount speakers can be heard at ear level (built in SRS FOCUS™ effect).
- 2) Ultra rich bass sound can be obtained from standard door mount speakers (built in SRS TruBass® effect).
- 3) Surround sound can be obtained

from 2-channel stereo sources such as CD, MP3 and FM (built in SRS Circle Surround II™ effect).

4) SRS CS Auto™ can position the center channel image in the center of the vehicle's windshield. This eliminates the need for a center speaker (built in SRS Circle Surround II™ phantom center and SRS FOCUS™ effects).

CS Auto, SRS and “” symbol are trademarks of SRS Labs, Inc.

CS Auto technology is incorporated under license from SRS Labs, inc.

▽ Position setting

Position setting is used to adjust the sound to the best condition for the selected seating position.

ALL: The sound is adjusted to the best for all seating positions.

FR: The sound is adjusted to the best for the front passenger.

FL: The sound is adjusted to the best for the driver.

■ Adjustable level of each mode

| Mode | | Range of levels (displayed) | Initial setting | Turn counterclockwise | Turn clockwise |
|------------------|------------------------|-----------------------------|-----------------|-----------------------------|-----------------------------|
| Volume | Volume control | 0 to 40 | 15 | For less volume | For more volume |
| | AUX volume control* | 0 to 40 | 15 | For less volume | For more volume |
| Tone and balance | Bass control | -8 to +8 | 0 | For less bass sound | For more bass sound |
| | Midrange control | -8 to +8 | 0 | For less midrange sound | For more midrange sound |
| | Treble control | -8 to +8 | 0 | For less treble sound | For more treble sound |
| | Fader | R9 to F9 | 0 | Front attenuated | Rear attenuated |
| | Balance | L9 to R9 | 0 | Right channel attenuated | Left channel attenuated |
| Other settings | SPEED VOLUME | OFF to 2 | OFF | For less auto volume change | For more auto volume change |
| | CS Auto (type A audio) | OFF to 2 | OFF | From 2 to 1, 1 to OFF | From OFF to 1, 1 to 2 |
| | POSITION | ALL, FR, FL | ALL | From FL to FR, FR to ALL | From ALL to FR, FR to FL |

*Only when an AUX audio product is connected.

FM/AM radio operation

Press the "FM" or "AM" button when the radio is off to turn on the radio.

■ FM selection

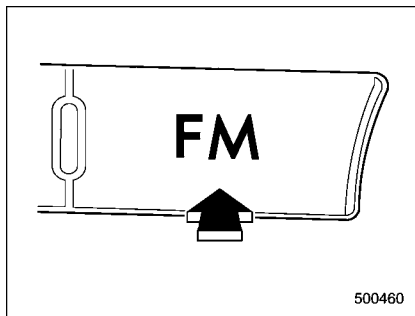

Press the "FM" button when the radio is on to select FM1, FM2 or FM3 reception.

Each brief press of the "FM" button changes the radio in the following sequence starting from the last FM radio band that you selected.

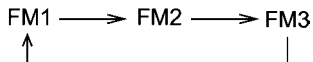

■ AM selection

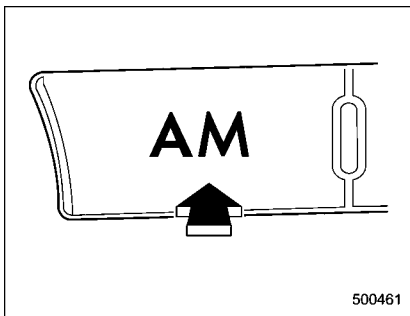

Press the "AM" button when the radio is on to select AM reception.

■ Tuning

▼ Manual tuning

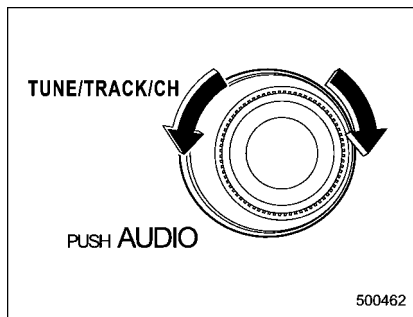

Turn the "TUNE/TRACK/CH" dial clockwise to increase the tuning frequency and turn the "TUNE/TRACK/CH" dial counter-clockwise to decrease it.

Each time the dial is turned, the frequency interval can be changed between 10 kHz in the AM mode and 0.2 MHz in the FM mode.

▼ Stereo indicator

The stereo indicator "ST" will illuminate when an FM stereo broadcast is received.

▼ Seek tuning (SEEK)

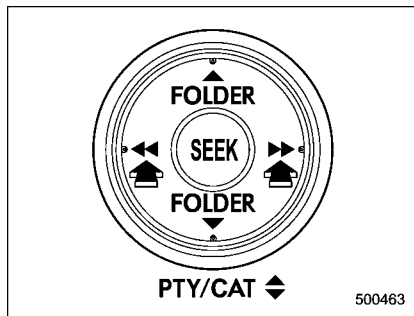

If you press the "◀◀" or "▶▶" side of the "SEEK" button briefly, the radio will automatically search for a receivable station and stop at the first one it finds. This function may not be available, however, when radio signals are weak. In such a situation, perform manual tuning to select the desired station.

▼ Scan tuning (SCAN)

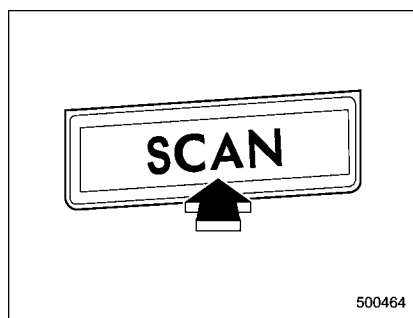

If you press the "SCAN" button, the radio will switch to the scan mode. In this mode, the radio scans through the radio band until a station is found. The radio will stop at the station for 5 seconds while displaying the frequency, after which scanning will continue until the entire band has been scanned.

Press the "SCAN" button again to cancel the SCAN mode. If you press the "SCAN" button while the radio is stopped at a station, the radio stays stopped at that station. If you press the button while the radio is scanning, the radio stops at the next receivable station.

Automatic tuning may not function properly if the station reception is weakened by distance from the station or proximity to

tall buildings and hills.

▼ PTY (Program type) group tuning (only FM reception)

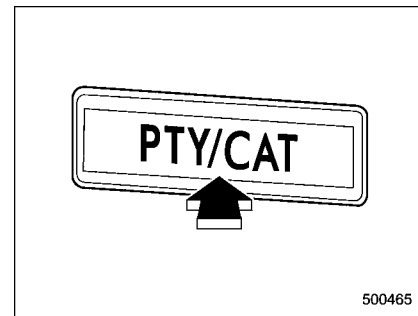

Press the "PTY/CAT" button to change to the PTY selection mode. At this time, the PTY group that you are currently listening to will be displayed for 10 seconds. In PTY selection mode, "PTY SEL" is displayed on the screen.

▽ PTY (Program type) group selection

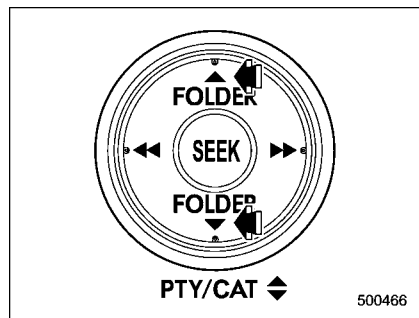

In PTY selection mode, press the “PTY” button “▲” or “▼” to change the PTY group by one step at a time.

Pressing “▲” changes the PTY group up by one step. Pressing “▼” changes the PTY group down by one step.

This operation only changes the display. It does not change the station that is currently being received.

▽ Seek in PTY (Program type) group

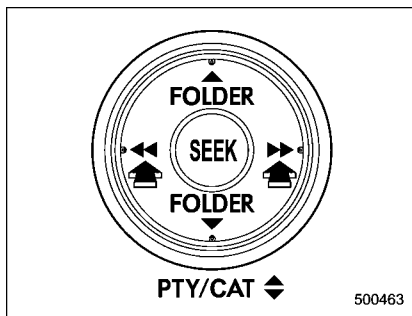

In the PTY selection mode, when the desired PTY group has been selected, pressing the “SEEK” button “▶▶” or “◀◀” seeks within that PTY group. In this case, “PTY SEEK” is displayed on the screen.

Pressing “▶▶” seeks up. Pressing “◀◀” seeks down.

The control function returns to the normal mode after approximately 10 seconds.

■ RDS text display

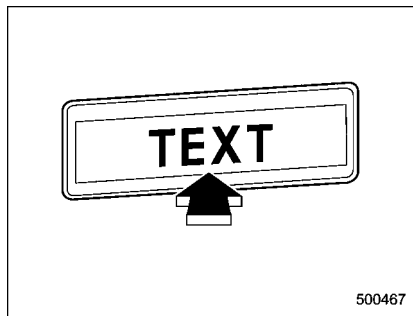

If the PS (Program Service Name) and/or RT (Radio Text) are available, pressing the “TEXT” button changes the display among PS, RT and frequency. The initial setting is “PS”.

NOTE

- The maximum number of characters that can be displayed for PS is 8.
- The maximum number of characters that can be displayed for RT is 64.
- If RT is 16 characters or longer, press and hold the “TEXT” button for 0.5 second or longer in order to change the page.

■ Station preset

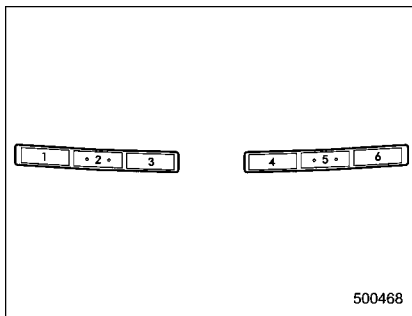

Preset buttons

▼ How to preset stations

1. Press the "FM" or "AM" button to select FM1, FM2, FM3 or AM reception.
2. Press the "◀" or "▶" side of the "SEEK" button or tune the radio manually until the desired station frequency is displayed.
3. Press one of the preset buttons for more than 1.5 seconds to store the frequency. If the button is pressed for less than 1.5 seconds, the preceding selection will remain in memory.

NOTE

- If the connection between the radio and battery is broken for any reason such as vehicle maintenance or radio removal, all stations stored in the preset buttons are cleared. If this occurs, it is necessary to reset the preset stations.
- If a cell phone is placed near the radio, it may cause the radio to emit noise when the phone receives calls. This noise does not indicate a radio fault.

▼ Selecting preset stations

Presetting a station with a preset button allows you to select that station in a single operation. Up to six AM, FM1, FM2 and FM3 stations each may be preset.

▼ Auto-store

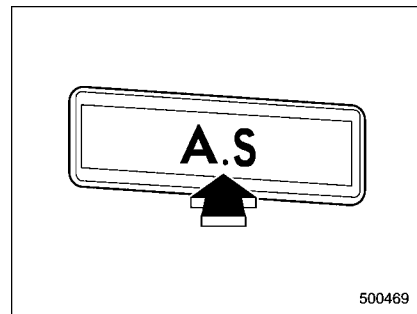

Using the Auto-store function, you can automatically store 6 stations on the current waveband by pressing the "A.S" button for more than 2 seconds. Use Auto-store to quickly find the strongest stations, for example when traveling through different reception areas.

NOTE

- When you use Auto-store, the new stations replace any stations previously stored.
- Interrupting Auto-store: If you accidentally press the "A.S" (Auto-store) button, you can cancel the Auto-store function before it has been completed as follows.
 - Switching to the other source

mode

- Switching to the other band
 - Press the “A.S” button
 - Press the “SCAN” button
 - Press the “SEEK” button
 - Press any of the preset buttons
 - Turn the “TUNE/TRACK/CH” dial
 - Turn off the audio system
 - Turn off the ignition switch
- When you use the Auto-store function while selecting the FM mode, even if you have selected the FM1 or FM2 station, the new stations are stored in the FM3 station.
 - If it is only possible to receive less than 6 stations, the available stations are stored from preset 1 in order by frequency and the unused preset buttons are not registered to a station. Also, the previously registered station memories of the unused preset buttons are cleared.
 - If no stations can be received, the previously stored stations are not replaced.
 - After pressing the “A.S” button, if more than 1 station is stored, the radio receives the station stored in preset 1.
 - After pressing the “A.S” button, if no stations are stored, the radio receives the band and station that the radio

received before pressing the button.

Satellite radio operation (if equipped)

To receive satellite radio, it is necessary to install the SUBARU genuine satellite receiver (dealer option) and to enter into a contract. For details, please contact your SUBARU dealer.

■ XM™ satellite radio

XM™ is a continental U.S. based satellite radio service, including music, news, sports, talk and children’s programming. XM™ provides digital quality audio and text information, including song title and artist name. A service fee is required to receive the XM™ service. For more information, contact XM™ at www.xmradio.com or call 1-800-XM-RADIO (1-800-967-2346) for U.S., www.xmradio.ca or 1-877-GET-XMSR (1-877-438-9677) for Canada.

■ Sirius satellite radio

Sirius satellite radio is a recent innovation that allows the listener to experience digital sound quality and to have a greater variety of channels.

Use of satellite radio (Sirius) requires a tuner, antenna and a service contract. For details, please contact your SUBARU

dealer or visit Sirius Satellite Radio at www.sirius.com or call 1-888-539-SIRIUS (7474) for more information. Sirius, the Sirius dog logo, channel names and logos are trademarks of SIRIUS Satellite Radio Inc.

■ Satellite radio reception

Satellite radio signals are best received in areas with a clear view of the open sky. In areas where there are tall buildings, trees, tunnels or other structures that may obstruct the signal of the satellites, there may be signal interruptions. Other circumstances that may result in signal loss include driving near a wall, steep cliff, hill or driving on the lower level of a multi-tiered road or inside of a parking garage. To help reduce this condition, satellite radio providers have installed ground-based repeaters in heavily populated areas. However, you may still experience reception problems in some areas.

■ Displaying satellite radio ID of tuner

When you activate satellite radio, you should have your satellite radio tuner ID ready because each tuner is identified by its unique satellite radio tuner ID.

The satellite radio ID will be needed when

you activate satellite radio and receive satellite radio customer support.

The satellite radio ID can be found on the audio display by tuning the channel to "000".

Turn the "TUNE/TRACK/CH" dial to select the satellite radio channel.

NOTE

For Sirius, change the display to an indication mode other than the channel number after performing the above operation.

■ Band selection

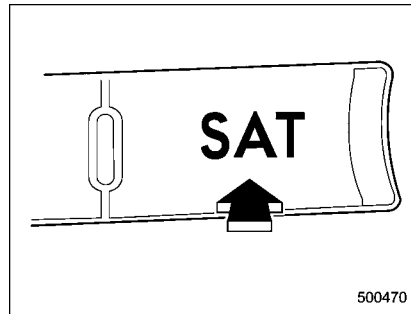

Press the "SAT" button when the radio is off to turn on the radio.

Press the "SAT" button when the radio is

on to select SAT1, SAT2 or SAT3 reception.

■ Channel and category selection

▼ Channel selection by operating the dial

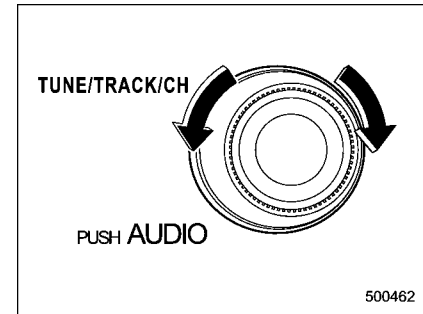

Turn the "TUNE/TRACK/CH" dial clockwise to select the next channel and turn the "TUNE/TRACK/CH" dial counterclockwise to select the previous channel.

▼ Channel selection by pressing the button

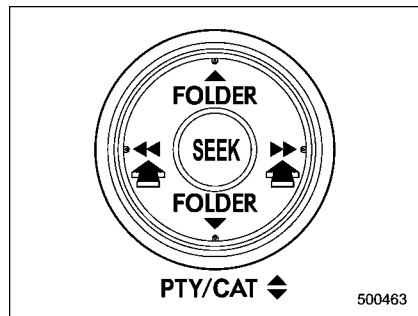

When in the SAT mode, briefly press the "SEEK" button "◀◀" or "▶▶" to select the channel.

▼ Skip channel selection

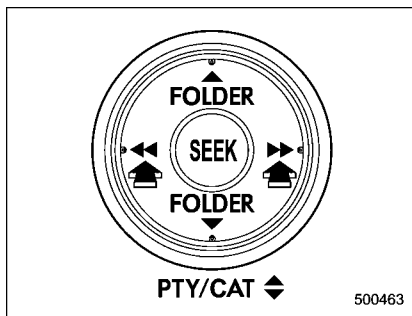

When in the SAT mode, press the "SEEK" button "◀◀" or "▶▶" continuously to change to the channel selection mode. Pressing the "SEEK" button "▶▶" changes the channel up by 10 steps each time. Pressing "◀◀" changes the channel down by 10 steps each time.

▼ Category selection

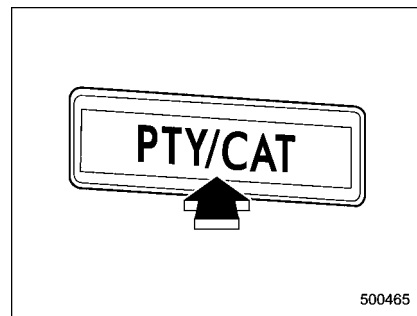

To activate the category search mode, press the "PTY/CAT" button. To deactivate the category search mode, press the "PTY/CAT" button again.

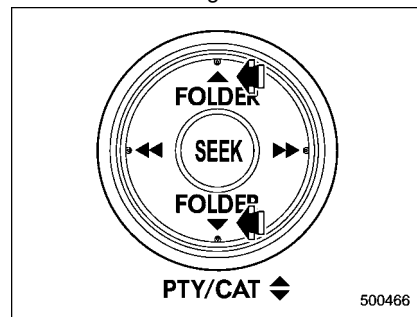

When in the category search mode,

pressing the “FOLDER” button “▲” changes the category up by one step. Pressing “▼” changes the category down by one step.

When a category is selected, pressing the “SEEK” button selects channels only within the selected category.

The control function returns to the normal mode after approximately 10 seconds.

▼ Channel scan

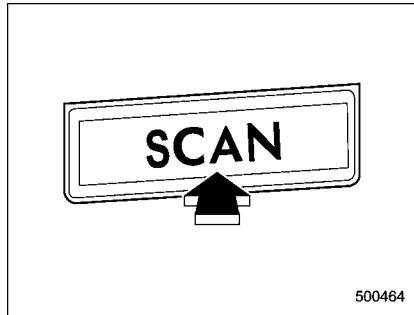

If you press the “SCAN” button while the radio is in the category search mode, the radio turns to the category SCAN mode. In the category SCAN mode, the radio scans only channels in the selected category.

If you press the “SCAN” button while the radio is not in the category search mode, the radio turns to the ALL SCAN mode. In

the ALL SCAN mode, the radio scans all channels.

In both SCAN modes, the radio will stop at the station for 5 seconds while displaying the channel number, after which scanning will continue until the entire channel has been scanned from the low end to the high end.

Press the “SCAN” button again to cancel the SCAN mode and to stop on any displayed channel.

■ Channel preset

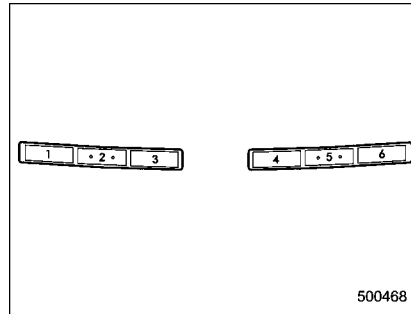

Preset buttons

▼ How to preset channels

1. Press the “SAT” button to select SAT1, SAT2 and SAT3 reception.
2. Select the desired channel.
3. Press one of the preset buttons for more than 1.5 seconds to store the channel. If the button is pressed for less than 1.5 seconds, the preceding selection will remain in memory.

NOTE

If the connection between the radio and battery is broken for any reason such as vehicle maintenance or radio removal, all channels stored in the preset buttons are cleared. If this occurs, it is necessary to reset the preset channels.

▼ Selecting preset channels

Presetting a channel with a preset button allows you to select that channel in a single operation. Up to six SAT1, SAT2 and SAT3 channels each may be preset.

■ Display selection

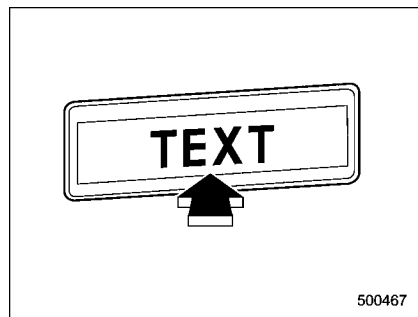

Press the “TEXT” button while receiving the satellite radio to change the display as follows:

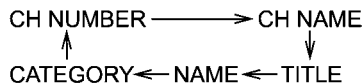

CD player operation

NOTE

- Make sure to always insert a disc with the label side up. If a disc is inserted with the label side down, the player displays “CHECK DISC”.

Refer to “When the following messages are displayed” 5-27.

- If a disc is inserted during a radio broadcast, the disc will interrupt the broadcast.

- After the last track finishes, the disc will automatically return to track 1 (the first track on the disc) and will automatically play back.

- The player is designed to be able to play music CD-Rs and music CD-RWs, but it may not be able to play certain ones.

- CDs (i.e., 8 cm/3 inch CDs) are not supported, and if inserted, they will be immediately ejected.

- Copyright protected WMA/AAC files will not be played by the system. The player will automatically skip to the next file (track).

- Audio data recorded in the MP3/WMA/AAC formats may not be played depending on the data recording condition.

■ How to insert a CD (type A)

While the ignition switch is in the “Acc” or “ON” position, hold a disc with a finger in the center hole while gripping the edge of the disc, then insert it in to the slot (with the label side up) and the player will automatically pull the disc into position.

NOTE

DO NOT INSERT TWO DISCS INTO THE DISC INSERTION SLOT AT A TIME.

■ How to insert a CD(s) (type B)

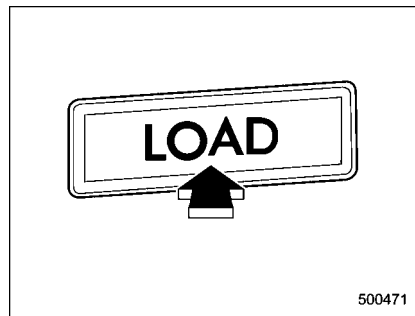

1. Briefly press the “LOAD” button. If the magazine in the player has an idle position where you can insert a disc, the disc number indicator associated with the idle position will blink.

If no indicator blinks, it means that there is no idle position in the magazine.

2. When the "LOAD" indicator illuminates, insert the disc. Once you have inserted the disc, the "LOAD" indicator will turn off and the "LOADING" indicator will illuminate. The disc will then be automatically drawn in, the player will begin to play back the first track of the disc, the "LOADING" indicator will turn off and the "READING" indicator will illuminate.

- To insert more discs in succession, repeat steps 1 and 2. The magazine will be loaded with discs in the ascending order of position number.
- If you do not insert any disc in 15 seconds after you have pressed the "LOAD" button, the player will return to the original mode that was selected before the "LOAD" button was pressed.
- The disc indicator steadily lights up if a disc is already inserted in the corresponding position of the magazine.
- While the player is in the loading mode, if you press "FM", "AM" or "SAT" button, the player will enter the standby mode. Press the "CD/AUX" button to start playback.

▼ Inserting a disc in a desired position

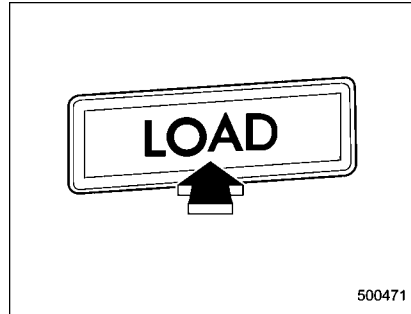

1. Briefly press the "LOAD" button. If the magazine in the player has an idle position where you can insert a disc, the disc number indicator associated with the idle position will blink.

The positions in the magazine the indicator of which steadily lights up are already loaded with discs.

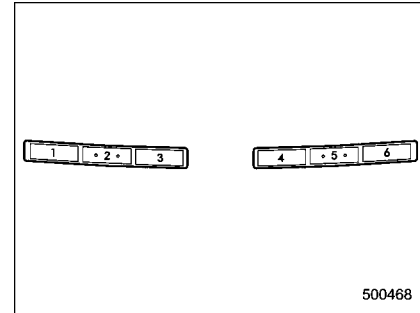

Disc select buttons

2. Press the disc select button at the position where you want to insert a disc.
 3. When the "LOAD" indicator illuminates, insert the disc. Once you have inserted the disc, the "LOAD" indicator will turn off. The disc will then be automatically drawn in, and the player will begin to play the first track on the disc.
- If you wish to insert another disc, repeat the procedure beginning with step 1.
 - If you do not insert any disc in 15 seconds after you have pressed the "LOAD" button, the player will return to the original mode that was selected before the "LOAD" button was pressed.
 - While the player is in the loading mode,

if you press “FM”, “AM” or “SAT” button, the player will enter standby mode. Press the “CD/AUX” button to start playback.

▼ **Loading all the magazine (full disc loading mode)**

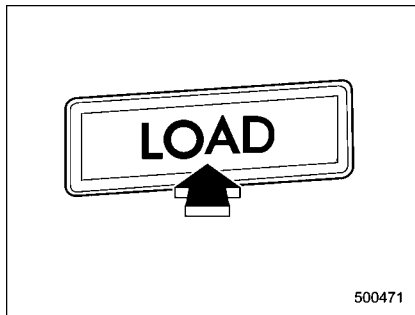

1. If you continue to press the “LOAD” button for more than 1.5 seconds, the player will produce beep sound and will enter the full disc loading mode.
2. When the disc number indicator flashes and “ALL LOAD” indicator illuminates, insert a disc within 15 seconds. If a disc is successfully loaded during this period, the disc number indicator will stop blinking and will steadily light.
3. When the loading of a disc is complete, the next idle disc number indicator will blink. Then repeat step 2.

4. When the magazine is filled with discs by repeating steps 2 and 3, the player will start playback of the discs, beginning with the one inserted first.

If you fail to insert any disc during each 15 seconds interval, the full disc loading mode will be canceled, and the player will start playback of the disc inserted first.

■ **How to play back a CD**

NOTE

For type A audio, if a disc that the player cannot read has been loaded, the player will display the message “CHECK DISC”.

▼ **When there is no CD inserted**

Insert a CD by referring to “How to insert a CD (type A)” 5-18 / “How to insert a CD (s) (type B)” 5-18.

When a CD is loaded, the player will start playback of the CD, beginning with the first track.

▼ **When CD is in the player (type A)/ When playing back all CDs in the player (type B)**

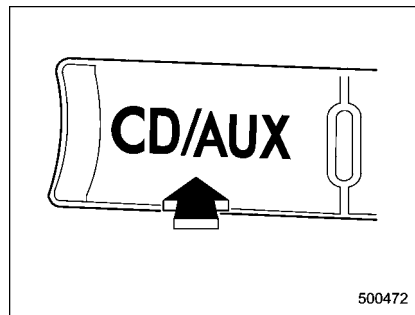

When the “CD/AUX” button is pressed, the player will start playback.

- ▼ When selecting a CD to play (type B)

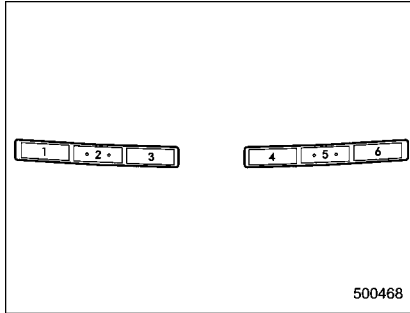

Disc select buttons

Press a desired one of the disc select buttons the disc number indicator of which steadily lights up. The player will then start playback of the selected CD, beginning with the first track.

- To select a track from its beginning

- ▼ Forward direction

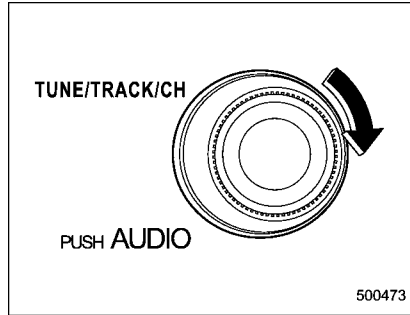

Turn the "TUNE/TRACK/CH" dial clockwise to skip to the beginning of the next track/file (track). Each time the dial is turned, the indicated track/file (track) number will increase.

NOTE

In an MP3, WMA or AAC folder, skipping past the last track/file (track) will take you back to the first track/file (track) in the folder.

- ▼ Backward direction

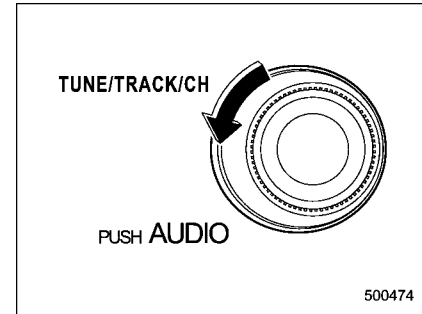

Turn the "TUNE/TRACK/CH" dial counter-clockwise to skip to the beginning of the current track/file (track). Each time the dial is turned, the indicated track/file (track) number will decrease.

NOTE

In an MP3, WMA or AAC folder, skipping past the first track/file (track) will take you to the last track/file (track) in the folder.

■ Fast-forwarding and fast-reversing

▼ Fast-forwarding

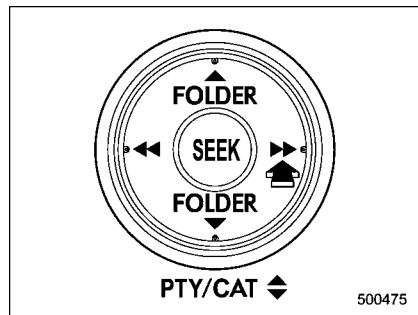

Press the “▶▶” side of the “SEEK” button continuously to fast-forward the track/file. Release the button to stop fast-forwarding.

NOTE

If you fast-forward to the end of the last track/file (track), fast-forwarding will stop and the player will start playback beginning with the first track/file (track).

▼ Fast-reversing

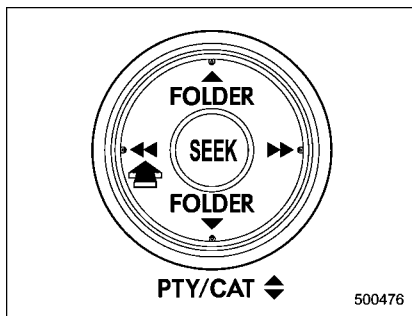

Press the “◀◀” side of the “SEEK” button continuously to fast-reverse the track/file. Release the button to stop fast-reversing.

NOTE

If you fast-reverse to the beginning of the first track/file (track), fast-reversing will stop and the player will start playback.

■ Repeating

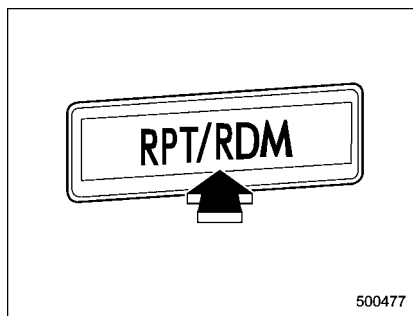

Type A audio

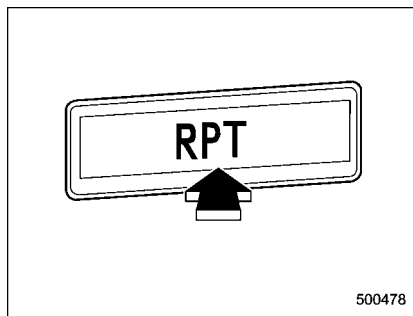

Type B audio

To repeat a track/file (track), briefly press the “RPT/RDM” button (type A audio) or

“RPT” button (type B audio) while the track/file (track) is playing.

Each time you briefly press the button, the mode changes in the following sequences.

Type A audio:

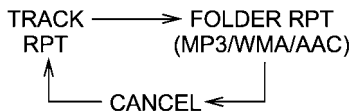

Type B audio:



NOTE

- The “TRACK RPT” indication refers to the repeat playback of a single track. It repeats the track that is playing.
- The “FOLDER RPT” indication refers to the repeat playback of a folder. It repeats the all of the tracks in the folder. It is possible to select the function when the MP3/WMA/AAC format track is playing.

- The “DISC RPT” indication refers to the repeat playback of a disc. It repeats the tracks on the CD. It is only possible to select this function for type B audio.

To cancel the track/file (track) repeat-play mode, briefly press the “RPT” button and select CANCEL. The “RPT” indication will turn off, and the normal playback mode will be resumed.

NOTE

The repeat-play mode will be cancelled if you perform any of the following steps:

- Press the “RPT/RDM” button and select CANCEL (type A audio)
- Press the “RPT” button and select CANCEL (type B audio)
- Press the “▲” button
- Press the disc select button
- Press the “SCAN” button
- Press the “LOAD” button when there is free space in the CD magazine

■ Random playback

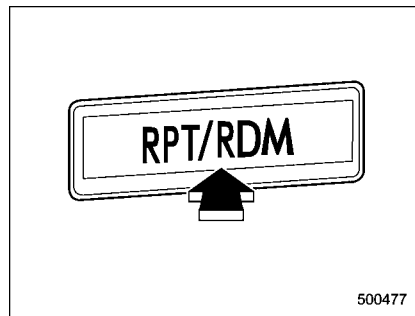

Type A audio

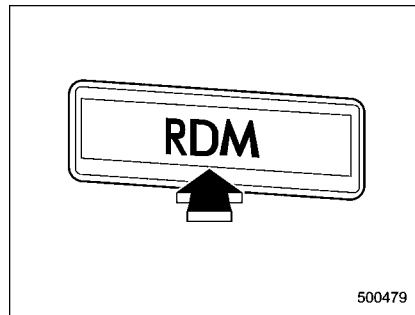

Type B audio

To play back a track/file(s) at random, press the “RPT/RDM” button for 0.5

second or longer (type A audio) or press the “RDM” button (type B audio).

- For type A audio, press the “RPT/RDM” button for 0.5 second or longer.
- For type B audio, press the “RDM” button.

Each time you press the button, the mode changes in the following sequences.

Type A audio:

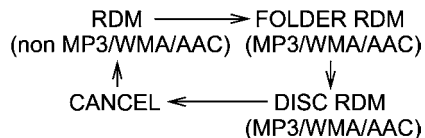

Type B audio:

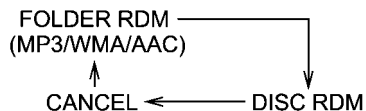

NOTE

- The “RDM” indication refers to the random playback of the tracks. It randomly repeats the tracks on the CD. It is possible to select the function when formats other than the MP3/WMA/AAC format CD is playing.
- The “FOLDER RDM” indication refers to the random playback in the

folder. It randomly repeats the tracks in the folder. It is possible to select the function when an MP3/WMA/AAC format track is playing.

- The “DISC RDM” indication refers to the random playback of a disc. It randomly repeats the tracks in the CD. It is possible to select the function when an MP3/WMA/AAC format track is playing.

To cancel the random playback mode, press the “RPT/RDM” button for 0.5 second or longer again (type A audio) or press the “RPT” button again (type B audio) and select CANCEL.

The “RDM” indication will turn off, and the normal playback mode will be resumed.

NOTE

Random playback will be cancelled if you perform any of the following steps:

- Press the “RPT/RDM” button for 0.5 second or longer and select CANCEL (type A audio)
- Press the “RPT” button and select CANCEL (type B audio)
- Press the “▲” button
- Press the disc select button
- Press the “SCAN” button
- Press the “LOAD” button when there is free space in the CD magazine
- Press the “▼” or “▲” side of the

“FOLDER” button

■ Scan

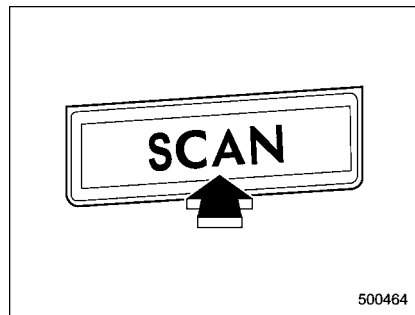

500464

The scan mode lets you listen to the first 10 seconds of each track/file in succession. Press the “SCAN” button to start scanning upward beginning with the track/file(s) following the currently selected one. After all track/file(s) in the disk/folder have been scanned, normal playback will be resumed. To cancel the scan mode, press the “SCAN” button again.

NOTE

The scan mode will be cancelled if you perform any of the following steps.

- Press the “RPT” button
- Press the “RDM” button

- Press the “RPT/RDM” button
- Turn the “TUNE/TRACK/CH” dial
- Press the “▼” or “▲” side of the “FOLDER” button
- Press the “▲” button
- Press the “◀” or “▶” side of the “SEEK” button
- Press the disc select button
- Select the radio or AUX mode
- Press the “LOAD” button when there is free space in the CD magazine
- Turn off the power of the audio equipment
- Turn the ignition switch to the “LOCK” position

■ Display selection

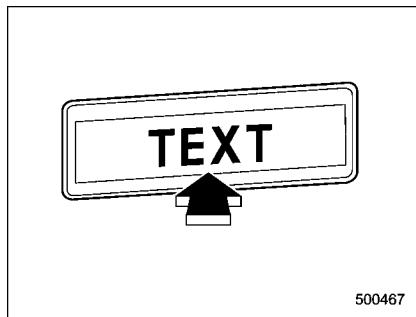

If you press the “TEXT” button during playback, the indication will change to the

next one in the following sequence.

For CD-DA:

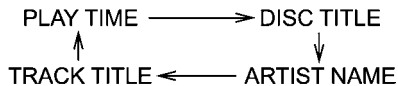

For MP3/WMA/AAC:

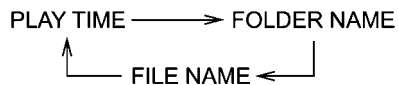

▼ Page (track/folder title) scroll

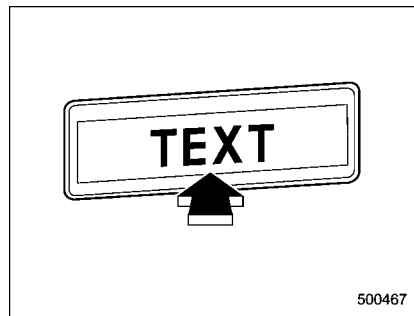

If you press the “TEXT” button again for at least 0.5 second, the title will be scrolled so you can see all of it.

NOTE

The display is designed to show titles for up to 30 characters.

■ Folder selection

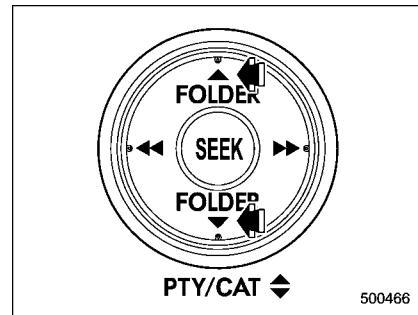

Press the “▲” side of the “FOLDER” button briefly to select the next folder. Press the “▼” side of the button briefly to go back to the previous folder.

NOTE

- Selecting folders in this way is possible only within a single disc.
- Only MP3/WMA/AAC folders are recognized when an attempt to select the next or previous folder is made. If no appropriate folder exists on the disc, pressing the “▲” or “▼” side of the

“FOLDER” button starts playback beginning with the first track/file (track).

■ How to eject a CD from the player (type A)

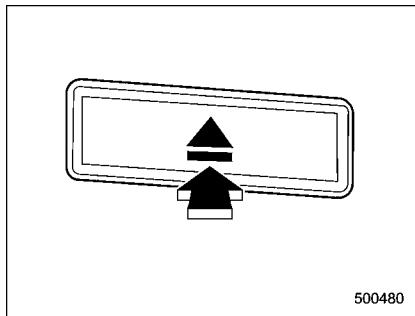

When a disc is being played back or when a disc is in the player, press the eject button “▲”. The disc will be ejected.

NOTE

- Avoid driving the vehicle with a CD sticking out, because vibration might make it fall out.
- If you do not remove the ejected disc within approximately 15 seconds, a disc protection function will operate, automatically reloading the disc. In this case, the disc is not played.

■ How to eject CDs from the player (type B)

NOTE

- Avoid driving the vehicle with a CD sticking out, because vibration might make it fall out.
- If you do not remove the ejected disc within approximately 15 seconds, a disc protection function will operate, automatically reloading the disc. In this case, the disc is not played.

▼ Ejecting a CD from the player

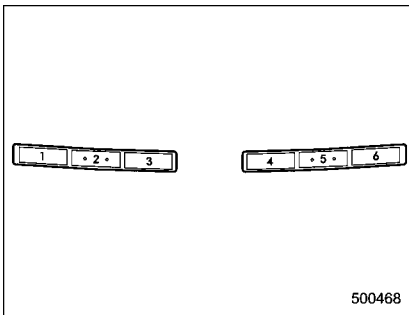

Disc select buttons

1. Use the disc select button to select the disc to be ejected.

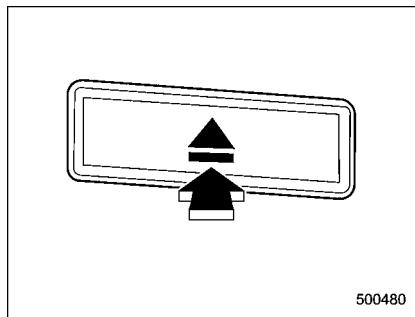

2. Briefly press the “▲” button. The selected disc will be ejected. The disc number indicator will flash at this time. When you remove the ejected disc, the disc number indicator will turn off.

To remove more discs in succession, repeat steps 1 and 2.

▼ **Ejecting all discs from the player
(all disc ejection mode)**

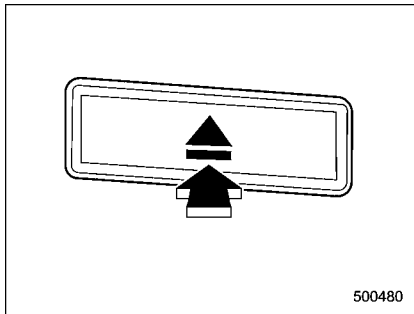

1. If you press the “▲” button for 1.5 seconds or longer, the player will produce beep sound and will enter the all disc ejection mode. At this time, the disc number indicator and “ALL EJECT” indicator will flash.

2. Remove the disc that has been ejected. The other discs loaded will then be ejected one after another.

NOTE

● If you press the “▲” button while the player is in all disc ejection mode, the mode will be cancelled following ejection of the disc that is currently being ejected.

● If you press the “CD/AUX” button or “LOAD” button while the player is in all disc ejection mode, the player will draw in the discs that have been ejected and play them.

■ **When the following messages are displayed**

If one of the following messages is displayed while operating the CD player, determine the cause based on the following information. If you cannot clear those messages, please contact your SUBARU dealer.

▼ **When “PUSH EJECT” is displayed**

Press the eject button to unload the disc. Check the disc for damage or deformation, and also check that the correct disc is inserted. Do not try to unload the disc forcibly. Single CDs (i.e., 8 cm/3 inch CDs) are not supported, and if inserted, they will be immediately ejected. If the disc cannot be unloaded or this message remains displayed, please contact your SUBARU dealer.

▼ **When “CHECK DISC” is displayed**

Press the eject button to unload the discs. Check that the disc is not damaged or scratched, and also check that the disc is inserted correctly. This message may appear when using some CD-RW discs.

Check that the disc type (i.e., 8 cm/3 inch CDs are not supported) and data format are correct. This player can only play CD-DA, MP3, WMA and AAC data formats. If the disc cannot be unloaded or this message remains displayed, please contact your SUBARU dealer.

AUX unit operation

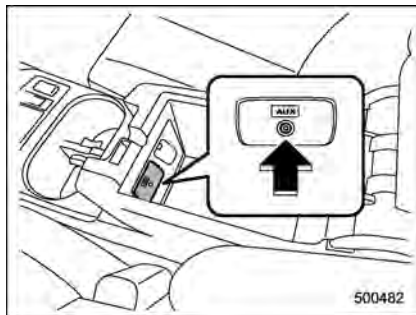

By connecting a commercial audio product to the vehicle, such as a portable audio player, you can hear its sound via the vehicle's speaker.

For the audio input jack, a stereo mini pin plug (3.5ø) can be connected. The connection cable is available at electrical appliance or similar stores.

To use the AUX unit:

1. Connect a portable audio player to the AUX jack.

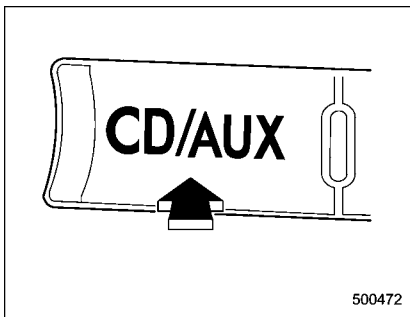

2. Press the AUX input selection button "CD/AUX" on the audio control panel to turn on the auxiliary audio input.
3. Play back the portable audio player. Refer to the Owner's Manual of the portable audio player.

NOTE

- **The output sound of the portable audio player is not loud, and the sound via the vehicle's speakers that are connected to the vehicle audio set is very low. If you turn up the volume of the audio set, the volume becomes louder. However, when you change the player to the other portable audio player, the sound may become a lot louder. Turn down the volume when you change between them.**

- **In some cases, when the sound volume of the portable audio player is low, the sound becomes bad when you turn up the volume of the vehicle audio system. In this case, adjust the sound volume of the portable audio player.**
- **In some cases, noise occurs because of a bad connection between the portable player and the audio system. Try cleaning the stereo jack and audio plug.**
- **If noise is not reduced, check for disconnection of the cord or malfunctions of the portable player.**

Precautions to observe when handling a compact disc

Use only compact discs (CDs, CD-Rs and CD-RWs) that have the mark shown in the following illustration. Also, some compact discs cannot be played.

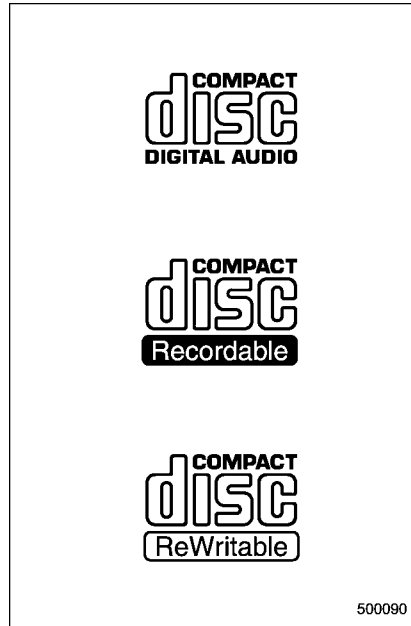

- You cannot use a DualDisc in the CD player. If you insert a DualDisc into the player, the disc may not come out again, possibly causing the player to malfunction.
- In cold and/or rainy weather, dew can form inside the CD player, preventing normal operation. If this happens, eject the CD and wait for the player to dry out.
- Skipping may occur when the CD player is subjected to severe vibration (for example, when the vehicle is driven on a rough surface).
- To remove a disc from the case, press the center of the case and hold both edges of the disc. If the disc surface is touched directly, contamination could cause poor tone quality. Do not touch the disc surface.
- Use a clean disc whenever possible. If

there are deposits, wipe the disc surface from the center outward with a dry, soft cloth. Be sure not to use a rough cloth, thinner, benzine, alcohol, etc.

- Do not use any disc that is scratched, deformed, or cracked. Also, do not use any disc that has a non-standard shape (for example, a heart shape). Malfunctions or problems might result.

- A disc is vulnerable to heat. Never keep it either in places exposed to direct sunlight, near heaters or in vehicles parked in the sun or on hot days.

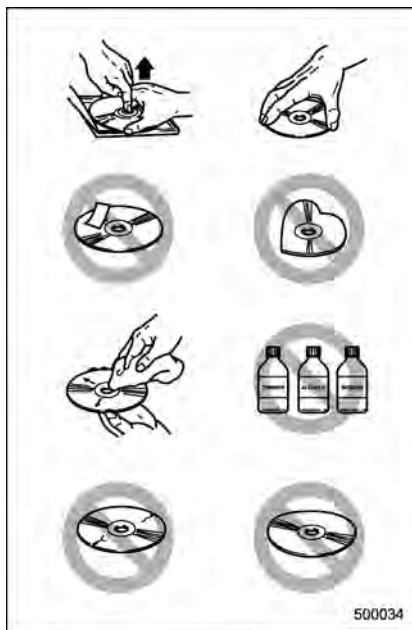

Audio control buttons (if equipped)

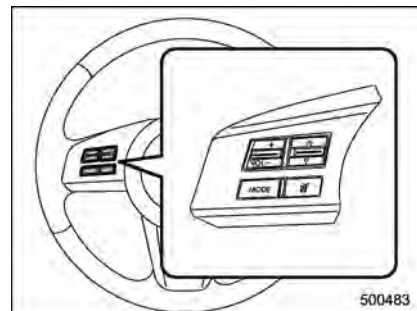

Type A audio

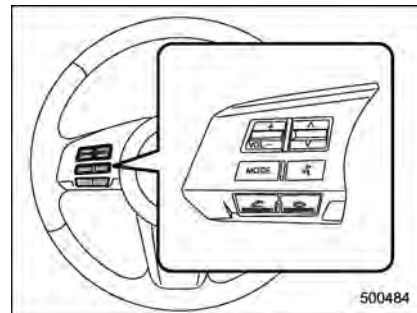

Type B audio

These buttons are located on the spokes of the steering wheel. They allow the driver to control audio functions without taking his/her hands off the steering wheel.

■ MODE button

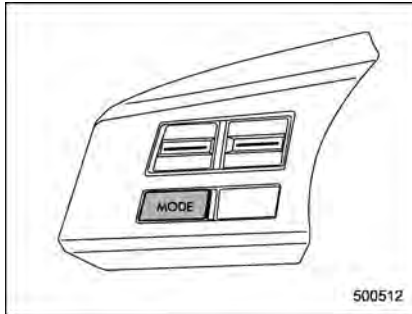

This button is used to select the desired audio mode. Each time it is pressed, the mode changes to the next one in the following sequence.

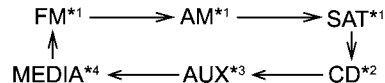

*1: The frequency last received in the selected waveband will be displayed.

*2: Only when a CD is in the player.

*3: Only when an auxiliary audio product is connected.

*4: Only when an iPod is connected using the iPod adapter that is available as a dealer option.

■ “^” and “v” switch

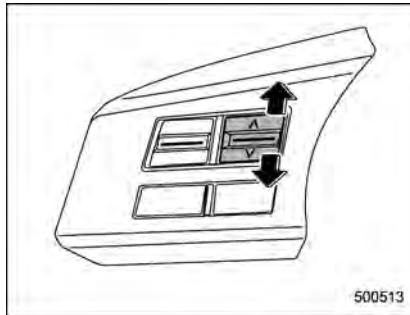

▼ With radio mode selected

Press the switch to the “^” or “v” side briefly to skip to a preset channel. Press the switch to the “^” or “v” side for more than 0.5 second to seek the next receivable station and stop at it.

That station’s frequency will be indicated on the audio display.

▼ With CD mode selected

Press the switch to the “^” side to skip forward in the track/file (track) order. Press

the switch to the “v” side to skip backward in the track/file (track) order.

The track/file (track) number will be shown on the audio display.

▼ With SAT mode selected

Press the switch to the “^” side to skip forward in the channel order. Press the switch to the “v” side to skip backward in the channel order. When the switch is briefly pressed, the channel will skip every 1 channel. When the switch is pressed for more than 0.5 second, the channel will skip every 10 channels. The channel will be shown on the audio display.

■ Volume control switch

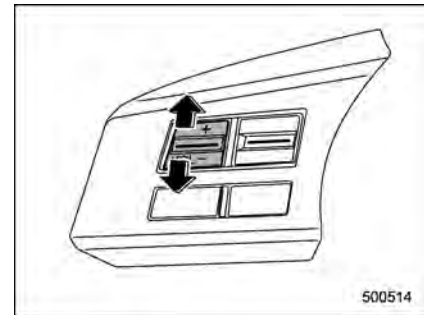

Press the switch to the “+” side to increase the volume. Press the switch to the “-”

side to reduce the volume.
A number indicating the volume will be shown on the audio display.

■ MUTE button (if equipped)

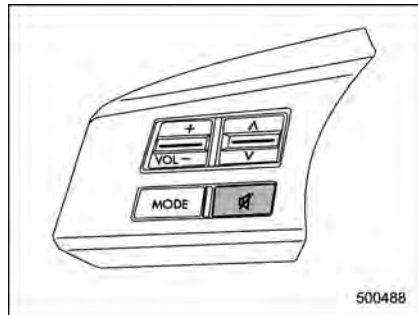

Press this button if you wish to immediately cut the volume to zero.

The audio display will show "MUTE".

If you press the button again, the original sound volume will return and "MUTE" turns off.

Hands-free system (if equipped)

NOTE

- For models with the genuine SUBARU navigation system, refer to the Owner's Manual supplement for the navigation system.
- When selling your vehicle, make sure that you initialize the Hands-free system to prevent personal data from being improperly accessed.

The Hands-free system operates while the ignition switch is in the "Acc" or "ON" position.

■ Tips for the Hands-free system

▼ Bluetooth®



NOTE

The Bluetooth word mark and logo are registered trademarks of Bluetooth SIG, Inc.

It is possible to connect a cell phone to the in-vehicle equipment through the Bluetooth® format (wireless) to make a phone call from the in-vehicle equipment or take an incoming phone call.

Since the Bluetooth® format is wireless, a connection between the in-vehicle equipment and the cell phone can be made without placing them in close vicinity of each other. The cell phone can be used

with it left in the breast pocket or bag.

NOTE

The Hands-free system may not operate properly under the following conditions.

- The cell phone is turned off.
- The cell phone is not in the phone call area.
- The battery of the call phone has run down.
- The cell phone is not connected to the Hands-free system.
- The cell phone is behind the seat or in the glove box.
- A metal material covers or touches the cell phone.

▼ Corresponding profiles for the cell phone

- HFP (Hands Free Profile): Ver. 1.0
- OPP (Object Push Profile): Ver. 1.1

■ Certification for the Hands-free system

NOTE

This device complies with Part 15 of the FCC Rules and with RSS-Gen of IC Rules. Operation is subject to the following two conditions: (1) This device may not cause harmful interfer-

ence, and (2) this device must accept any interference received, including interference that may cause undesired operation.

Changes or modifications not expressly approved by the party responsible for compliance could void the user's authority to operate the equipment.

NOTE

This equipment has been tested and found to comply with the limits for a Class B digital device, pursuant to Part 15 of the FCC Rules. These limits are designed to provide reasonable protection against harmful interference in a residential installation. This equipment may cause harmful interference to radio communications, if it is not installed and used in accordance with the instructions. However, there is no guarantee that interference will not occur in a particular installation. If this equipment does cause harmful interference to radio or television reception, which can be determined by turning the equipment off and on, the user is encouraged to try to correct the interference by one or more of the following measures.

- Reorient or relocate the receiving antenna.
- Increase the separation between the equipment and receiver.
- Connect the equipment into an outlet on a circuit different from that to which the receiver is connected.
- Consult the dealer or an experienced radio/TV technician for help.

■ Safety precautions



WARNING

- For safety reasons, avoid operating of the cell phone while driving.
- Do not make a phone call while driving. When you have an incoming call, stop the vehicle in a safe location before taking the incoming phone call. When you have to absolutely take a phone call, tell the caller "I'll call you back". And then call the caller back after stopping the vehicle in a safe location.
- Part 15 FCC Rules
FCC Warning:
Any unauthorized changes of modifications to this equipment

would void the user's authority to operate this device.

CAUTION

- Do not leave the cell phone in the vehicle. The temperature in the vehicle may become extremely high and cause a malfunction of the cell phone.
- When using the cell phone, be careful not to get it close to the in-vehicle equipment. Getting it too close to the in-vehicle equipment may result in deterioration in tone quality or a poor connecting condition.
- In the frequency band used by this equipment, along with industrial, scientific and medical equipment such as a microwave oven, radio stations (a license is required) to be used by the production line in the factory to identify movable bodies, specific small power radio stations (a license is not required) and amateur radio stations (a license is required) are being operated. (These three types of radio stations are hereinafter referred to

as "other radio stations".) Before using this equipment, be sure to check to see if "other radio stations" are being operated in the vicinity. If there is detrimental radio interference from this equipment to "other radio stations", move the equipment to another location as soon as possible to avoid radio interference. The frequency band used by this equipment is in the 2.4 GHz zone. The FH-SS modulation is employed as a modulation method. The expected inflicting interference distance is less than 33 ft (10 m). This equipment uses a full band and can avoid a band used by a movable body identification device.

■ Using the Hands-free system

▼ Turning on/off the Hands-free mode

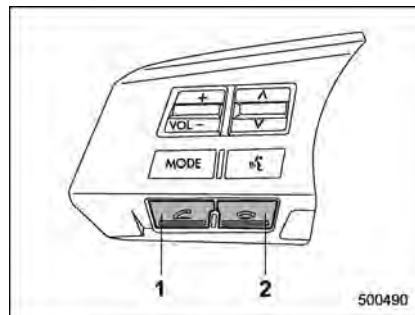

- 1) OFF hook switch
- 2) ON hook switch

To turn on the Hands-free mode, press the OFF hook switch. To turn off the Hands-free mode, press the ON hook switch.

▼ Preparation for using the Hands-free system

Before using the Hands-free system, it is necessary to register a cell phone in the system. Perform the following procedure to register a cell phone.

1. Press the OFF hook switch.
2. Select "Set up" by operating the "TUNE/TRACK/CH" dial.
3. Select "Phone setup" by operating the

“TUNE/TRACK/CH” dial.

4. Select “Pair phone” by operating the “TUNE/TRACK/CH” dial.
5. Press the talk switch. Refer to “Voice command system” 5-40.
6. Say the name to be registered.
7. Select “Confirm” by operating the “TUNE/TRACK/CH” dial or say “Confirm”. Then a pass key is displayed.
8. Input the displayed pass key into the cell phone while “PASS KEY: ****” is displayed. If you input the correct pass key, “Paired” is displayed and the registering procedure is finished. If you input an incorrect pass key, “Failed” is displayed and the registering procedure was not successful.

▼ Inputting the phone number

1. Press the OFF hook switch.
2. Select “Phonebook” by operating the “TUNE/TRACK/CH” dial.
3. Select “Add Entry” by operating the “TUNE/TRACK/CH” dial.
4. Select “Manual Input” by operating the “TUNE/TRACK/CH” dial.
5. Input the phone number to be registered.

NOTE

While inputting the phone numbers, if “Go Back” is chosen using the “TUNE/TRACK/CH” dial, the character that was input last is deleted.

▼ Registering the phonebook data.

1. Input the phone number to be registered. Refer to “Inputting the phone number” 5-35.
2. Say the name to be registered.
3. “Confirm” is displayed.
4. Press the “TUNE/TRACK/CH” dial.
5. “Stored” is displayed.
6. Select “Speed Dial” by operating the “TUNE/TRACK/CH” dial.
7. Select the phone number to be registered.

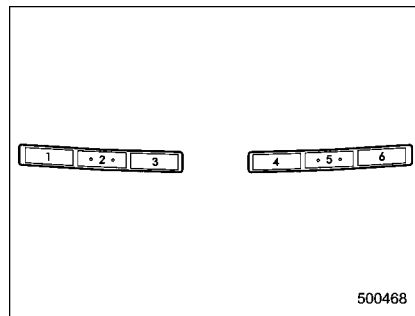

Preset buttons

8. Press the preset button in which you want to register the number. The number is then registered.

▼ Page scroll

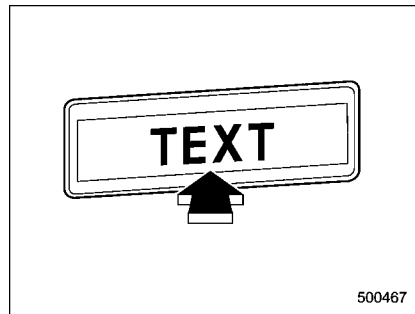

If the registered name or phone number has more than 12 characters, press the "TEXT" button for more than 1.5 seconds to scroll the name or phone number.

▼ Making a phone call

▽ Making a phone call from the phone book

It is possible to select a phone number from the phonebook registered with the in-vehicle equipment to make a phone call.

1. Press the OFF hook switch.

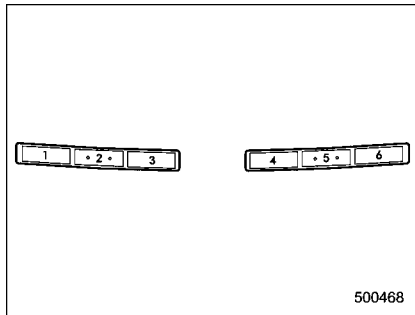

Preset buttons

2. Press the preset button in which the desired number is registered.
3. Press the OFF hook switch again.

NOTE

When a preset button for which numbers are not registered is pressed, an error message is indicated on the audio screen.

▽ Redial

1. Select "Redial" by operating the "TUNE/TRACK/CH" dial.
2. Press the OFF hook switch.

▽ Callback

1. Select "Callback" by operating the "TUNE/TRACK/CH" dial.
2. Press the OFF hook switch.

▼ Taking a phone call and declining an incoming call

To take a phone call: Press the OFF hook switch.

To put an incoming call on hold: Press the ON hook switch briefly.

To decline an incoming call: Press the ON hook switch for more than 1.5 seconds.

▼ Volume control

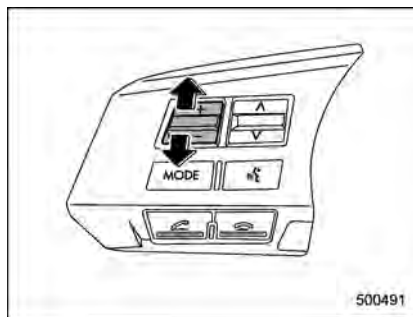

You can adjust the phone call volume, the voice volume and the voice guidance volume. Refer to "Volume control switch" 5-31.

▽ Adjustable level of each volume

| Volume | Range | Initial setting |
|----------------|---------|-----------------|
| Phone call | 0 to 14 | 7 |
| Voice | 0 to 14 | 7 |
| Voice guidance | 1 to 7 | 4 |

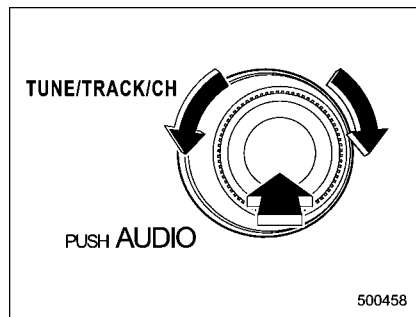
▼ Menu list of the Hands-free system

Turn the "TUNE/TRACK/CH" dial to select a menu, and then press the dial to enter the selected menu.

NOTE

For details about the operation, follow the voice guidance.

| First menu | Second menu | Third menu | Details |
|------------|--------------|------------|---|
| Phonebook* | Add Entry | — | Adding a new number |
| | Change Name | — | Changing a name registered in the phonebook |
| | List Names | — | Showing the list of the names registered in the phonebook |
| | Speed Dial | — | Registering a speed dial |
| | Delete Entry | — | Deleting phonebook data |
| | Del Spd Dial | — | Deleting a registered speed dial. |
| | Go Back | — | |
| Redial | — | — | Redialing |
| Callback | — | — | Dialing a number stored in the incoming call history memory |

*: If a cell phone is not registered, the menu described in the chart is not indicated.

| First menu | Second menu | Third menu | Details |
|------------|--------------|--------------|--|
| Setup | Security | Set Pin | Setting a PIN code |
| | | Phbk Lock | Locking the phonebook* |
| | | Phbk Unlock | Unlocking the phonebook* |
| | | Go Back | |
| | Phone setup | Pair Phone | Registering a new cell phone |
| | | Select Phone | Selecting a cell phone to be used |
| | | Change Name | Changing the registered name of the cell phone |
| | | List Phones | Showing the list of the registered cell phones |
| | | Set Passkey | Changing the pass key |
| | | Delete | Deleting the registered cell phone |
| | | Go Back | |
| | System setup | Guidance Vol | Setting the volume of the voice guidance |
| | | Initialize | Initialization |
| | | Go Back | |
| | Go Back | — | |

*: If a PIN code is not registered, the menu described in the chart is not available.

▼ Voice command system

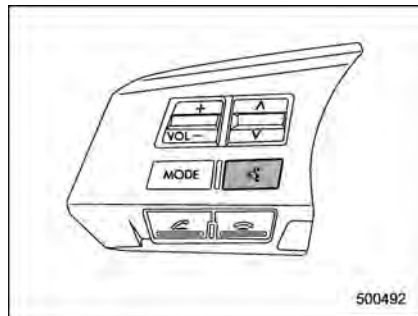
**Talk switch**

To turn on the voice command system, press the talk switch briefly. To turn off the voice command system, press the talk switch for more than 1.5 seconds.

The commands available for the voice command system are listed in the following chart.

| | Command |
|----|----------------|
| 1 | 0 (zero, oh) |
| 2 | 1 (one) |
| 3 | 2 (two) |
| 4 | 3 (three) |
| 5 | 4 (four) |
| 6 | 5 (five) |
| 7 | 6 (six) |
| 8 | 7 (seven) |
| 9 | 8 (eight) |
| 10 | 9 (nine) |
| 11 | * (star) |
| 12 | # (pound) |
| 13 | + (plus) |
| 14 | double |
| 15 | callback |
| 16 | redial |
| 17 | dial by number |
| 18 | dial by name |
| 19 | phonebook |
| 20 | setup |

| | |
|----|------------------------------|
| 21 | phone book add entry |
| 22 | phone book change name |
| 23 | phone book delete entry |
| 24 | phone book list names |
| 25 | phone book set speed dial |
| 26 | phone book delete speed dial |
| 27 | phone book unlock |
| 28 | cancel |
| 29 | help |
| 30 | repeat |
| 31 | go back |
| 32 | mute |
| 33 | call transfer |
| 34 | dial |
| 35 | previous |
| 36 | delete |
| 37 | store |
| 38 | confirm |
| 39 | phone setup |
| 40 | security |
| 41 | pair phone |
| 42 | change name |
| 43 | select phone |
| 44 | list phones |

| | |
|----|-------------------|
| 45 | set pass key |
| 46 | list phone |
| 47 | add entry |
| 48 | delete entry |
| 49 | delete speed dial |
| 50 | by voice |
| 51 | voice |
| 52 | by phone |
| 53 | phone |
| 54 | call history |
| 55 | by call history |
| 56 | set speed dial |
| 57 | next |
| 58 | incoming |
| 59 | outgoing |
| 60 | list names |
| 61 | set PIN |
| 62 | phone book lock |
| 63 | PIN setup |
| 64 | send |

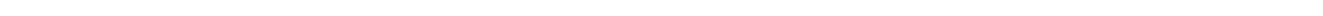
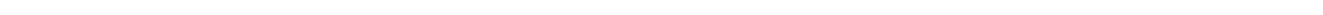
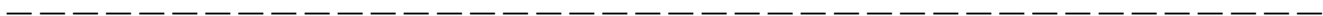
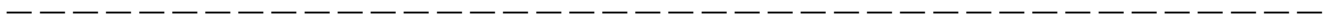

| | | | |
|--------------------------------------|------|--|------|
| Interior light | 6-2 | Ashtray (if equipped) | 6-12 |
| Dome light | 6-2 | Coat hook | 6-13 |
| Map light..... | 6-2 | Shopping bag hook | 6-14 |
| Cargo area light (Outback)..... | 6-3 | Legacy | 6-14 |
| Sun visors | 6-4 | Outback | 6-14 |
| Sun visor extension plate | 6-4 | Floor mat | 6-14 |
| Vanity mirror with light | 6-5 | Cargo area cover (if equipped) | 6-15 |
| Storage compartment | 6-5 | Using the cover | 6-15 |
| Glove box | 6-6 | To remove the cover housing..... | 6-16 |
| Center console box | 6-6 | Stowage of the cargo area cover | 6-16 |
| Overhead console | 6-8 | To install the cover housing | 6-17 |
| Pocket (if equipped) | 6-8 | Convenient tie-down hooks (if equipped) | 6-17 |
| Cup holder | 6-8 | Under-floor storage compartment | 6-18 |
| Front passenger's cup holder..... | 6-9 | Rear view camera (if equipped) | 6-19 |
| Rear passenger's cup holder..... | 6-9 | How to use the rear view camera | 6-20 |
| Bottle holders | 6-9 | Viewing range on the screen..... | 6-21 |
| Accessory power outlets | 6-10 | Help line..... | 6-22 |

Interior light

When leaving your vehicle, make sure the light is turned off to avoid battery discharge.

■ Dome light

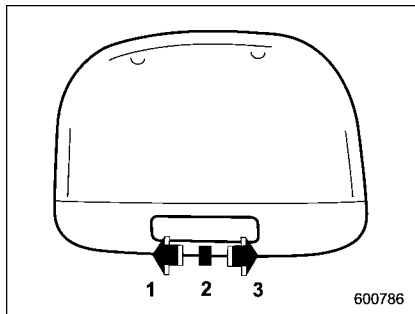

- 1) ON
- 2) DOOR
- 3) OFF

The dome light switch has three positions:

ON: The light remains on continuously.

OFF: The light remains off.

DOOR: The dome light illuminates automatically in the following cases.

- Any of the doors or the rear gate (Outback) is opened.

- The doors or the rear gate (Outback) are unlocked using the remote keyless entry transmitter.

- The ignition switch is turned from the "Acc" position to the "LOCK" position.

The automatically illuminated dome light remains on for several seconds and then gradually turns off after all doors and the rear gate (Outback) are closed. While the light is on, if any of the following operations are performed, the dome light turns off immediately.

- The ignition switch is turned from the "LOCK" position to "Acc" or "ON" position.

- All doors and the rear gate (Outback) are locked using the remote keyless entry transmitter.

The setting of the period for which the light remains on (OFF delay timer) can be changed by a SUBARU dealer. Contact your SUBARU dealer for details.

■ Map light

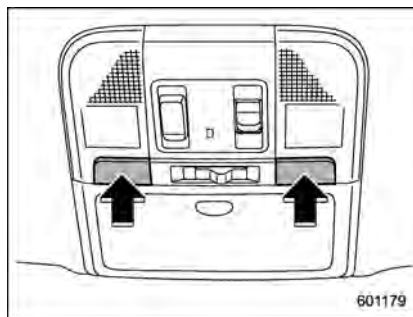

Models with moonroof

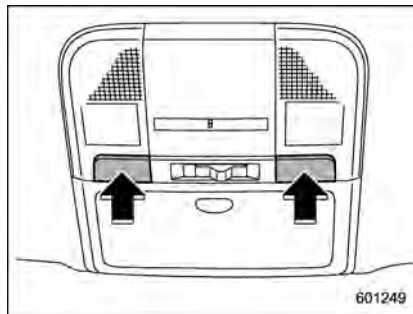

Models without moonroof

To turn on the map light, press the switch. To turn it off, press the switch again.

When leaving the vehicle, make sure the light is turned off to avoid battery discharge.

▼ Door interlock switch

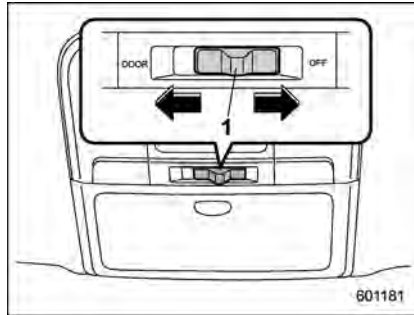

1) Door interlock switch

Although the map light switches are in the OFF position (manually off), the map lights can be set to illuminate automatically in conjunction with a door opening, etc. by use of the door interlock switch. The door interlock switch has the following two positions.

OFF: The map lights do not illuminate automatically in conjunction with a door opening. But, the lights can be turned on manually by pressing the map light switches.

DOOR: The map lights illuminate automatically in the following cases.

- Any of the doors (other than the rear gate or trunk lid) is opened. The map lights do not illuminate when only the rear gate is opened.
- The doors are unlocked using the remote keyless entry transmitter.
- The ignition switch is turned from the "Acc" position to the "LOCK" position.

The automatically illuminated map lights remain on for several seconds and then gradually turn off after all doors are closed. While the lights are on, if any of the following operations are performed, the map lights turn off immediately.

- The ignition switch is turned from the "LOCK" position to the "Acc" or "ON" position.
- All doors are locked using the remote keyless entry transmitter.

The setting of the period for which the lights remain on (OFF delay timer) can be changed by a SUBARU dealer. Contact your SUBARU dealer for details.

■ Cargo area light (Outback)

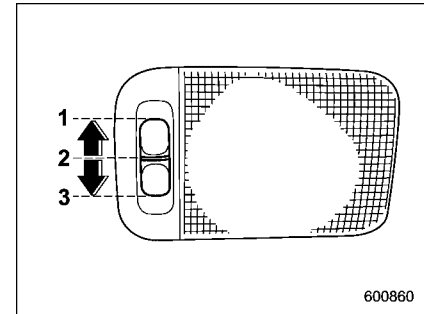

- 1) DOOR
- 2) OFF
- 3) ON

The cargo area light switch has three positions.

DOOR: The light illuminates only when the rear gate is opened.

OFF: The light remains off.

ON: The light remains on continuously.

The automatically illuminated cargo area light remains on for several seconds and then gradually turns off after the rear gate is closed. While the light is on, if any of the following operations are performed, the cargo area light turns off immediately.

6-4 Interior equipment

- The ignition switch is turned from the “LOCK” position to the “Acc” or “ON” position.
- The rear gate is locked using the remote keyless entry transmitter.

The setting of the period for which the lights remain on (OFF delay timer) can be changed by a SUBARU dealer. Contact your SUBARU dealer for details.

Sun visors

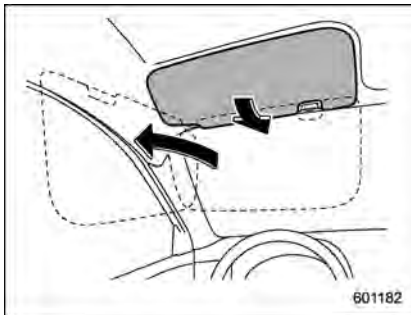

To block out glare, swing down the visors. To use the sun visor at a side window, swing it down and move it sideways.

■ Sun visor extension plate

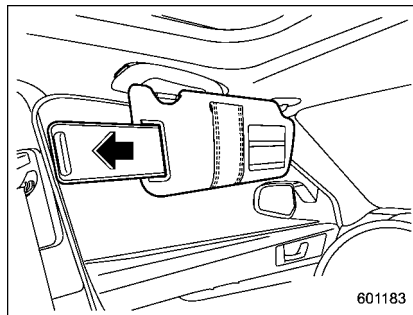

With the sun visor positioned over the side window, you can use the sun visor extension plate to prevent glare through the gap between the sun visor and center pillar. To use the extension plate, pull it toward the rear of the vehicle. When you have finished using it, stow it by pushing it toward the front of the vehicle.

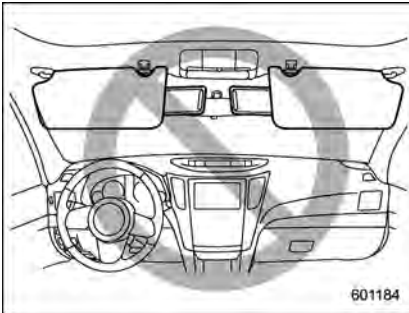

CAUTION

Do not pull out the extension plate with the sun visor positioned over the windshield. The extension plate would obstruct your view of the rearview mirror.

Vanity mirror with light

CAUTION

Keep the vanity mirror cover closed while the car is being driven to avoid being blinded by glare.

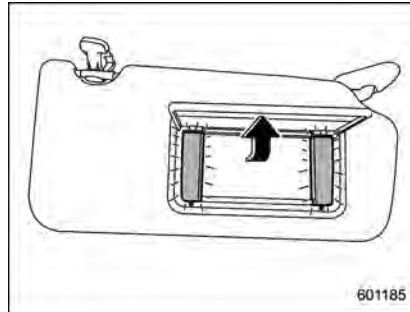

To use the vanity mirror, swing down the sun visor and open the vanity mirror cover. The lights beside the vanity mirror illuminate when the mirror cover is opened.

NOTE

Use of the vanity mirror light for a long period of time while the engine is not running can cause battery discharge.

Storage compartment

CAUTION

- Always keep the storage compartment closed while driving to reduce the risk of injury in the event of sudden stops or an accident.
- Do not store spray cans, containers with flammable or corrosive liquids or any other dangerous items in the storage compartment.

■ Glove box

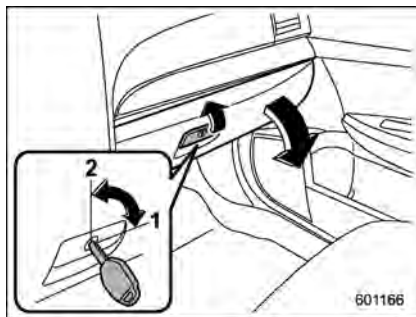

- 1) Lock
- 2) Unlock

To open the glove box, pull the handle. To close it, push the lid firmly upward.

To lock the glove box, insert the key and turn it clockwise. To unlock the glove box, insert the key and turn it counterclockwise.

■ Center console box

▼ Center console box (front)

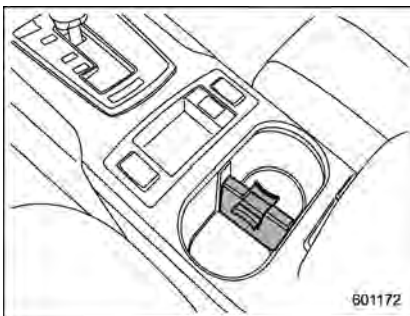

If you remove the divider plate from the dual cup holders, you can use the center console box as a storage space.

To use as storage space:

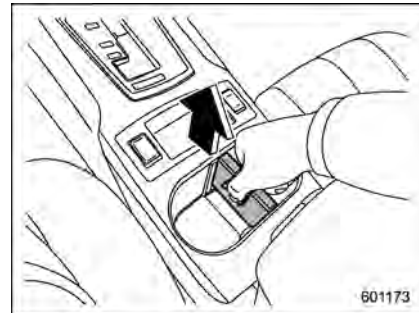

Pull out the divider plate of the dual cup holder.

To use again as cup holders:

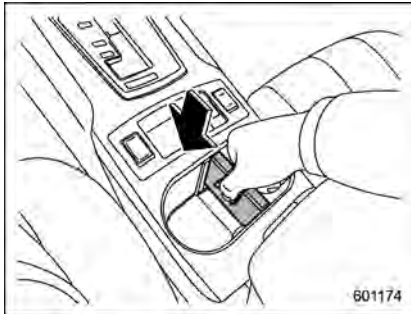

Insert the divider plate into the console box.

▼ Center console box (rear)

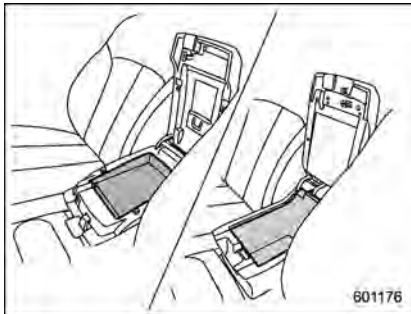

The center console box has a two-layer structure consisting of an upper compart-

ment and a lower compartment.

▼ Upper compartment

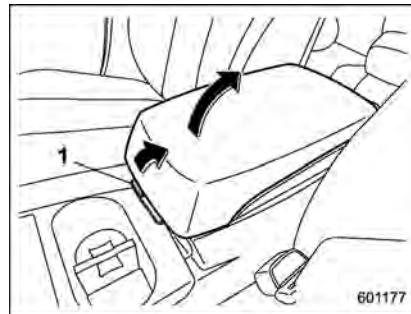

1) Upper compartment lock release

Pull up the upper compartment lock release to open the upper compartment.

▼ Lower compartment

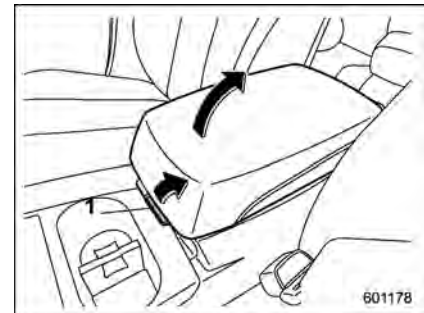

1) Lower compartment lock release

Pull up the lower compartment lock release to open the lower compartment.

■ Overhead console

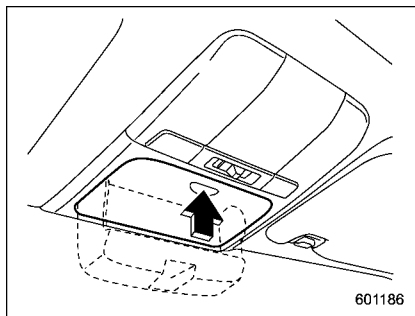

To open the console, push on the lid lightly and it will automatically open.

▲ CAUTION

When your vehicle is parked in the sun or on a warm day, the inside of the overhead console heats up. Avoid storing plastic or other heat-vulnerable or flammable articles such as a lighter in the overhead console.

■ Pocket (if equipped)

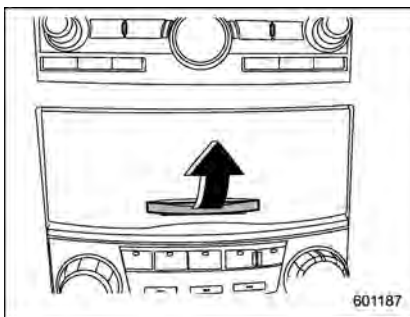

▲ CAUTION

Do not use the pocket as an ashtray or leave a lighted cigarette in the pocket. This could cause a fire.

To use the pocket, open the lid.

Cup holder

▲ CAUTION

- Do not pick up a cup from the cup holder or put a cup in the holder while you are driving, as this may distract you and lead to an accident.
- Take care to avoid spills. Beverages, if hot, might burn you or your passengers. Spilled beverages may also damage upholstery or carpets.

■ Front passenger's cup holder

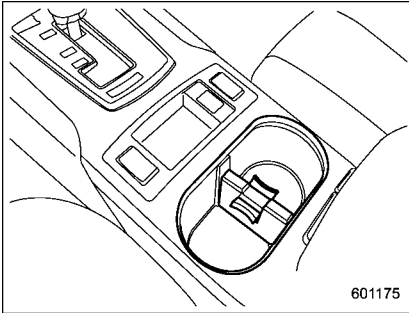

The dual cup holder is built into the center console.

■ Rear passenger's cup holder



A dual cup holder is built in the armrest.

⚠ CAUTION

When a cup containing a beverage is in the cup holder, do not fold down or recline any seat. Otherwise, the beverage could spill while driving and, if the beverage is hot, it could scald you.

⚠ CAUTION

- Do not pick up a bottle from the bottle holder or put a bottle in the holder while you are driving, as this may distract you and lead to an accident.
- When placing a beverage in a door pocket, make sure it is capped. Otherwise, the beverage could spill when opening/closing the door or while driving and, if the beverage is hot, it could scald you.

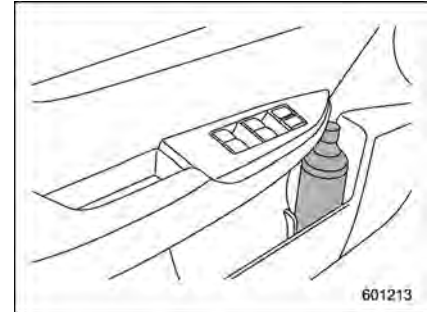

The door pocket equipped on each door

trim can be used to hold beverage bottles and other items.

Accessory power outlets

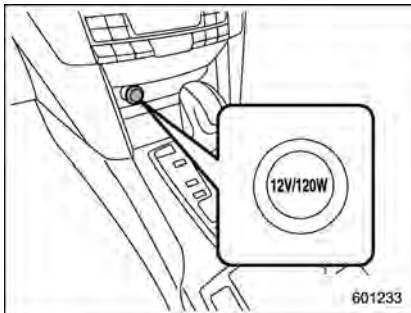

Power outlet below the climate control

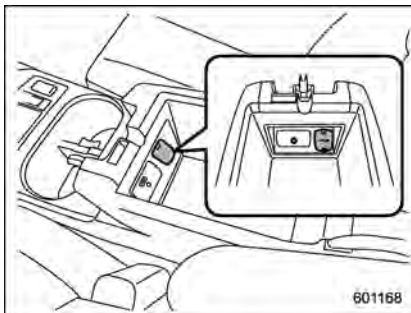

Power outlet in the center console

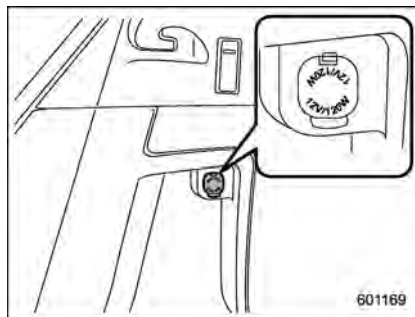

Power outlet in the cargo area (if equipped)

Accessory power outlets are provided below the climate control, in the center console and in the cargo area. Electrical power (12V DC) from the battery is available at any of the outlets when the ignition switch is in either the "Acc" or "ON" position.

You can use an in-vehicle electrical appliance by connecting it to an outlet.

The maximum power rating of an appliance that can be connected is **120W**. Do not use an appliance which exceeds the indicated wattage for each outlet.

When using appliances connected to two or more outlets simultaneously, the total power consumed by them must not exceed 120W.

CAUTION

- Do not attempt to use a cigarette lighter in the accessory power outlet.
- Do not place any foreign objects, especially metal ones such as coins or aluminum foil, into the accessory power outlet. That could cause a short circuit. Always put the cap on the accessory power outlet when it is not in use.
- Use only electrical appliances which are designed for 12V DC.

The maximum power rating of an appliance that can be connected is 120W. Do not use an appliance which exceeds the indicated wattage for each outlet.

When using appliances connected to two or more outlets simultaneously, the total power consumed by them must not exceed 120W. Overloading the accessory power outlet can cause a short circuit. Do not use double adapters or more than one electrical appliance.

- If the plug on your electric appliance is either too loose or too

tight for the accessory power outlet, this can result in a poor contact or cause the plug to get stuck. Only use plugs that fit properly.

- Use of an electric appliance in the accessory power outlet for a long period of time while the engine is not running can cause battery discharge.
- Before driving your vehicle, make sure that the plug and the cord on your electrical appliance will not interfere with your shifting gears and operating the accelerator and brake pedals. If they do, do not use the electrical appliance while driving.

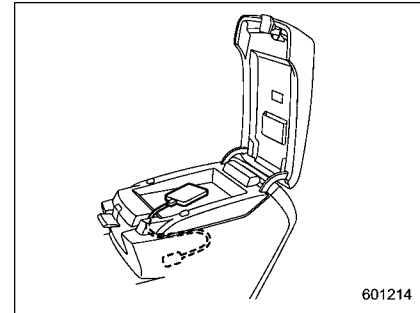

601214

Upper compartment

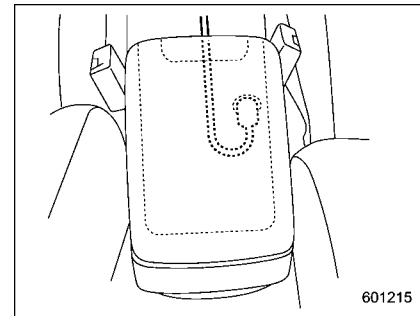

601215

Lower compartment

NOTE

When the lid of the center console is closed, a gap remains between the center console and the lid to allow the

power outlet in the center console to be used. Pass the cord of the electrical appliance through this gap.

Ashtray (if equipped)

 **CAUTION**

Do not use ashtrays as waste receptacles or leave a lighted cigarette in an ashtray. This could cause a fire.

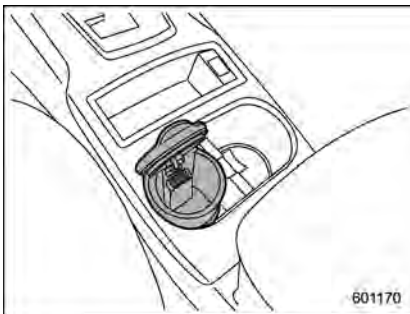

Ashtray in the front passenger's cup holder

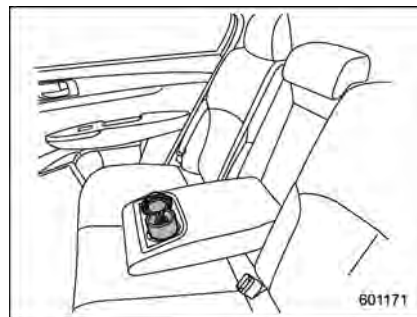

Ashtray in the rear passenger's cup holder

A portable ashtray is available from your SUBARU dealer. It fits into one of the cup holders built into the center console or the rear seat armrest.

When using the ashtray, open the ashtray lid. Fully close the lid after using it to help reduce residual smoke.

NOTE

Particles of ash and tobacco will accumulate around the hinges of the ash-tray's inner lid. Clean them off using a toothbrush or another narrow-ended implement.

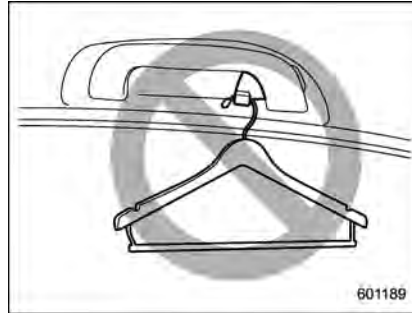
Coat hook**WARNING**

Do not hang coat hangers or other hard or pointed objects on the coat hooks. If such items were hanging on the coat hooks during deployment of the SRS curtain airbags, they could cause serious injuries by coming off the coat hooks and being thrown through the cabin or by preventing correct airbag deployment. Before hanging clothing on the coat hooks, make sure there are no pointed objects in the pockets. Hang clothing directly on the coat hooks without using hangers.

CAUTION

Never hang anything on the coat hook that might obstruct the driver's view or that could cause injury in sudden stops or in a collision. And do not hang items on the coat hook that weigh 11 lbs (5 kg) or more.

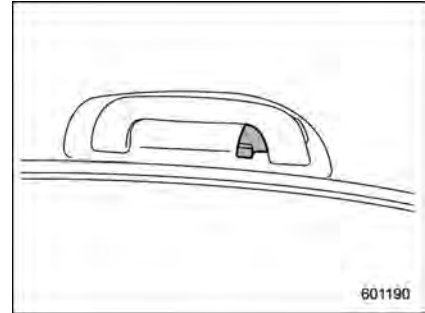

The coat hook is attached to each rear passenger's hand grip.

Shopping bag hook



Do not hang items on the shopping bag hook that weigh 11 lbs (5 kg) or more.

■ Legacy

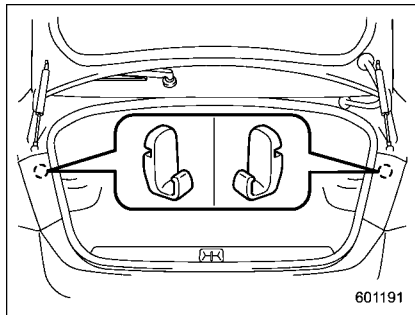

A shopping bag hook is attached to each inner side wall of the trunk near the trunk lid opening.

■ Outback

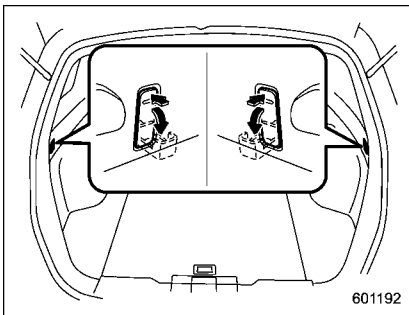

A shopping bag hook is attached to each side of the cargo area.

To use the hook, push the upper portion and the shopping bag hook will appear.

Floor mat

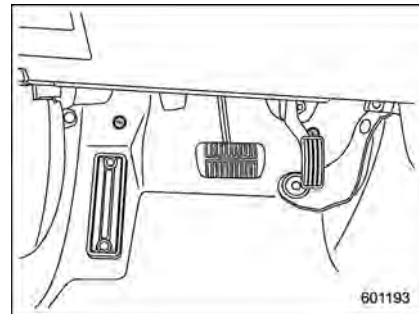

A retaining pin is located on the driver's side floor. Fit the grommet in the carpet onto the pin to prevent the carpet from moving.



CAUTION

Make sure the driver's floor mat is placed back in its proper location and correctly secured on its retaining pin. Also, do not use more than one floor mat. If the floor mat slips forward and interferes with the movement of the pedals during driving, it could cause an accident.

Cargo area cover (if equipped)

The cargo area cover is provided for covering the cargo area and to protect its contents from direct sunlight. This cover is detachable to make room for additional cargo.

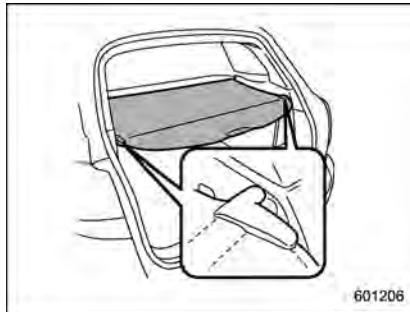
■ Using the cover

To extend the cover, pull the end of the cover out of the housing, then insert its hooks into the catches as shown. To rewind it, unhook it from the catches and it will rewind automatically. You should hold on to the cover and guide it back into the cover housing while it is rewinding.

WARNING

Do not place anything on the extended cover. Putting excessive weight on the extended cover can break it and an object on the cover could tumble forward in the event of a sudden stop or collision. This could cause serious injury.

CAUTION

- Be careful not to scratch the rear gate stays while extending and rewinding the cover. Scratches on the stays could cause leakage of gas from the stays, which may result in their inability to hold the rear gate open.
- When reclining the rear seatback, move the front cover backward so that the cover is not damaged.

■ To remove the cover housing

1. Rewind the cover.

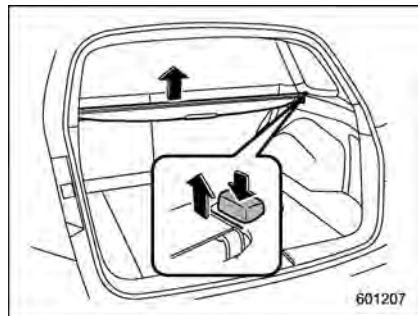

2. Hold down the button on the right-hand rear quarter panel and lift up the right-hand cover housing.
3. Remove the cover housing.

■ Stowage of the cargo area cover

The cargo area cover can be stowed in under the cargo floor.

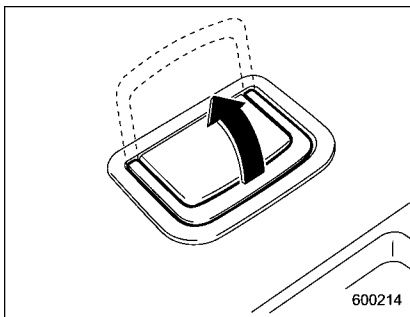

1. To open the lid, pull the handle up.

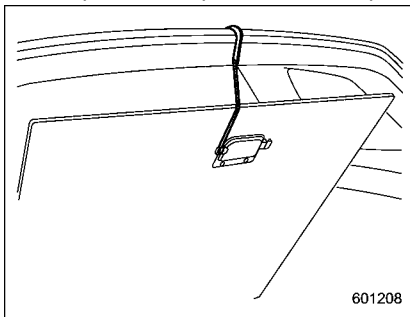

2. To keep the lid open, hang the hook (provided on the back of the lid) on the rear edge of the roof.

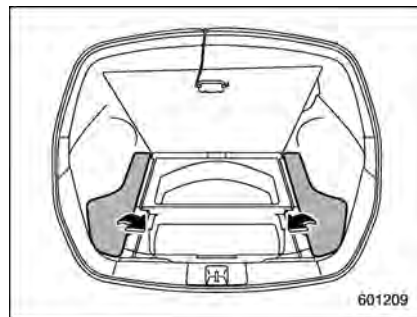

3. Remove the left and right parts of the cargo floor lid.

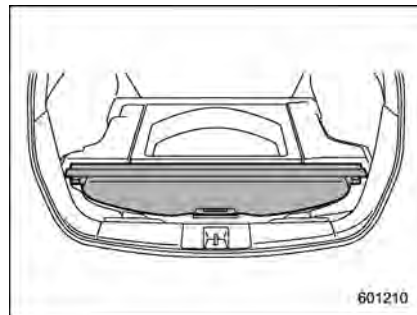

4. Stow the cover housing in the cargo area end.

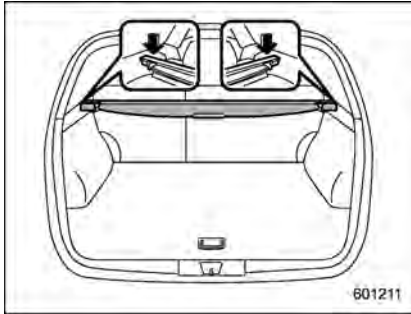
■ To install the cover housing

1. To install the cover housing, insert both ends of the cover housing into the retainers.

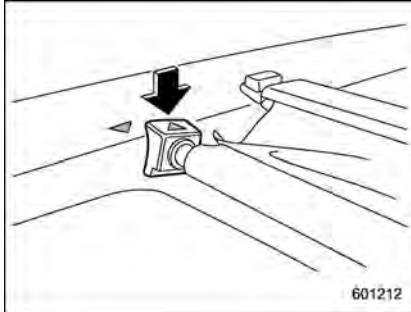

2. Make sure to fix the front part of the

cargo area cover behind the rear seat.

Convenient tie-down hooks (if equipped)**⚠ CAUTION**

The convenient tie-down hooks are designed only for securing light cargo. Never try to secure cargo that exceeds the capacity of the hooks. The maximum load capacity is 44 lbs (20 kg) per hook.

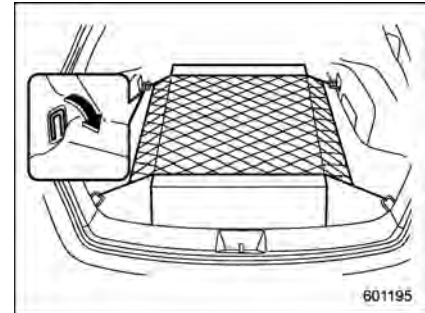

The cargo area is equipped with four tie-down hooks so that cargo can be secured with a luggage net or ropes.

When using the tie-down hooks, turn them down out of the storing recesses. When not in use, put the hooks up into the

– CONTINUED –

storing recesses.

Under-floor storage compartment

The subfloor storage compartment is located under the floor of the trunk or cargo area and can be used to store small items. To open the lid, pull the tab or handle up.

NOTE

When storing a flat tire, put the sub-floor storage in the trunk or cargo area.

CAUTION

- Always keep the lid of the sub-floor storage compartment closed while driving to reduce the risk of injury in the event of sudden stop or an accident.
- Do not store spray cans, containers with flammable or corrosive liquids or any other dangerous items in the subfloor storage compartment.

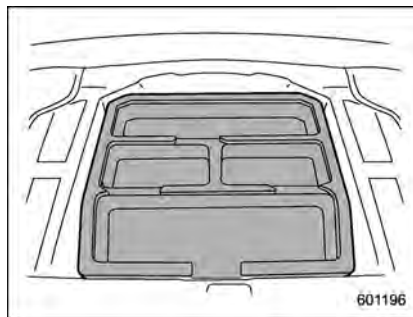

Legacy

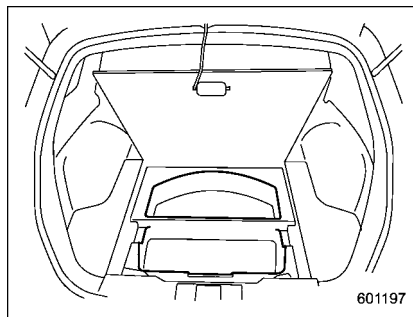

Outback

Hang the hook provided on the underside of the lid on the rear edge of the roof to keep the lid open.

Rear view camera (if equipped)

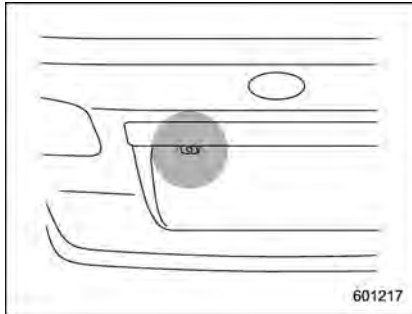

601217

Legacy

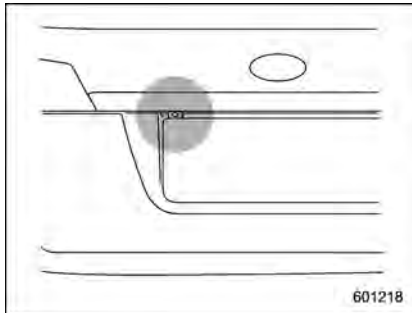

601218

Outback

A rear view camera is attached to the trunk lid (Legacy) or rear gate (Outback). When the ignition switch is "ON" and the shift lever (MT models) or select lever (AT or CVT models) is set to "R", the rear view camera automatically displays the rear view image from the vehicle on the navigation monitor.

WARNING

- Since the rear view camera uses a wide-angle lens, the image on the monitor is different from the actual view in terms of distance.
- Since the range of the image on the monitor is limited, you should always check the rear view and the surrounding area with your eyes and mirrors, and move backward at a slow speed. Moving backward only by checking the monitor could cause an accident.
- Do not disassemble or modify the camera, switch or wiring. If smoke comes out or you smell a strange odor, stop using the rear view camera immediately. Contact your SUBARU dealer for an inspection. Continued use may result in accident, fire or

electric shock.

CAUTION

- If your vehicle is washed with a high-pressure washer, do not allow water to contact the camera directly. Entry of water in the camera lens may result in condensation, malfunction, fire or electric shock.
- Since the camera is a precision device, do not subject it to strong impacts. Otherwise, malfunction, fire or electric shock may occur.
- If mud or snow sticks to or is frozen on the camera, you must be very careful removing it. Otherwise, damage done to the camera may cause a fire or electric shock. Pour water or lukewarm water over the camera to remove mud and ice, and wipe it with a soft, dry cloth.
- Do not put a flame close to the camera or wiring. Otherwise, damage or fire may occur.
- When replacing the fuse, be sure to use a fuse with the specified rating. Use of a fuse with a different rating may result in a

malfunction.

- If the rear view camera is used for a long time while the engine is not operated, the battery may become completely discharged.

NOTE

- Do not wipe the camera with alcohol, benzine or paint thinner. Otherwise, discoloration may occur. To remove contamination, wipe the camera with a cloth moistened with a diluted neutral detergent and then wipe it with a soft, dry cloth.
- When waxing the vehicle, be careful not to apply the wax to the camera. If it comes in contact with the camera, moisten a clean cloth with a diluted neutral detergent to remove the wax.
- The camera lens has hard coating to help prevent scratches. However, when washing the vehicle or cleaning the camera lens, be careful not to scratch the camera lens. Do not use a washing brush directly on the camera lens. The monitor screen may be adversely affected.
- Strong light shined on the camera lens may develop white light stripes around the light source. This is not a malfunction.

- Under fluorescent light, the display may flicker. However, this is not a malfunction.
- The image of the rear view camera may be slightly different from the actual color of the objects.

■ How to use the rear view camera

When the shift lever or select lever is set to "R", the rear view camera automatically displays the rear view image from the vehicle. When the lever is set to other positions, the image before setting to "R" is displayed.

1. Set the ignition switch to "ON".
2. Set the shift lever or select lever to "R".

NOTE

- For models with the genuine SUBARU navigation system, the image of the rear view camera has priority over other screen displays. Therefore, while the rear view camera is in operation, the operations of other screens are disabled. To operate other screens, set the shift lever or select lever to a position other than "R".
- The image of the rear view camera is horizontally reversed as is the case with the vehicle rearview mirror or the

side view mirror.

- It may be difficult to see the image of the rearview camera in the following cases. This is not a malfunction of the camera.
 - The vehicle is in a dark place (at night, in a tunnel, etc.).
 - The vehicle is in an extremely hot or cold place.
 - An object (such as raindrops, snow, dirt, etc.) that disturbs the view of the rear view camera sticks to the lens of the camera.
 - Strong light shined directly on the camera lens (occasionally, there are vertical lines on the screen).

■ Viewing range on the screen

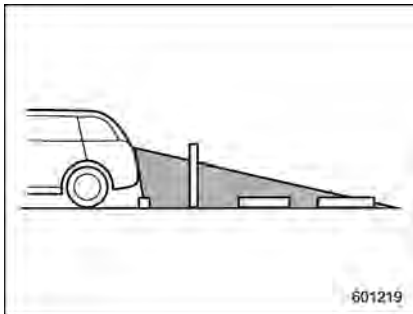

601219

Range of view

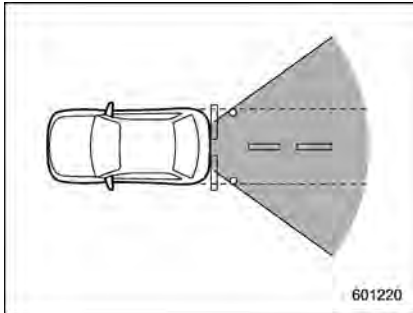

601220

Range of view

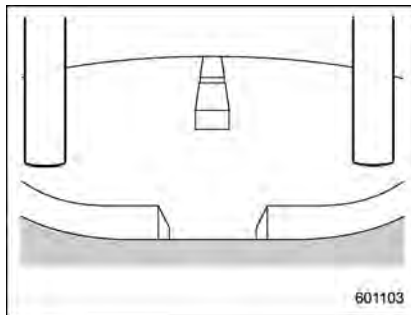

601103

Image from camera

The area from the rear end of the bumper can be viewed. Areas at both ends of the bumper and areas just under the bumper cannot be viewed.

Also, the image from the rear view camera looks shorter than the actual distance.

CAUTION

The range that can be viewed with the rear view camera is limited. Always be sure to check with your eyes when moving backward and proceed slowly.

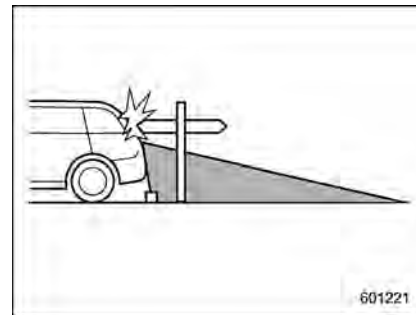

601221

Range of view

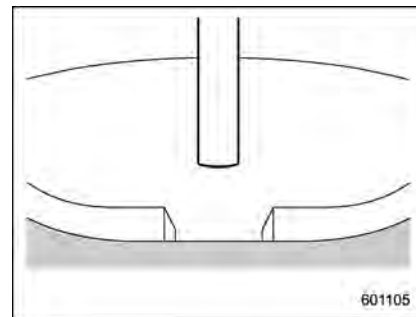

601105

Image from camera

The area above the camera cannot be viewed. If there is an object that has a wide projection on its upper part such as a sign pole behind the vehicle, the projec-

tion cannot be seen on the screen.



CAUTION

The range that can be viewed with the rear view camera is limited. Always be sure to check with your eyes when moving backward and proceed slowly.

■ Help line

The help line (distance marker and vehicle width line) is a guide to help you realize the actual distance from the screen.

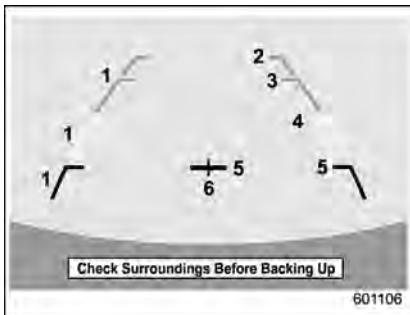

- 1) Vehicle width line (oblique vertical line)
- 2) Approx. 10 feet (3 m) from the bumper (green horizontal line)
- 3) Approx. 6.5 feet (2 m) from the bumper (green horizontal line)
- 4) Approx. 3 feet (1 m) from the bumper (yellow horizontal line)
- 5) Approx. 1.5 feet (0.5 m) from the bumper (red horizontal line)
- 6) Vehicle centerline

When the shift lever or select lever is set to position "R", the monitor screen displays the help lines together with the rear view image.



CAUTION

- When moving backward, always check the back with your eyes without relying on the help lines.
- The actual position may be different from the indication of the help lines.
- Differences may occur due to number of passengers or loaded cargo.
- When the vehicle is on a slope or when the vehicle is inclined against the road, the indication is different from the actual position.

▼ Difference between screen and actual road

The distance markers show the distance for a level road when the vehicle is not loaded. It may be different from the actual distance depending on the loading conditions or road conditions.

▽ When there is an upward slope at the back

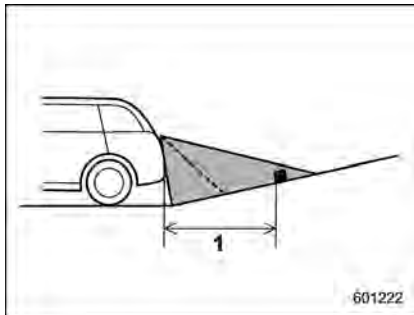

- 1) 3 feet (1 m)

The distance on the screen looks farther than the actual distance.

▽ When there is a downward slope at the back

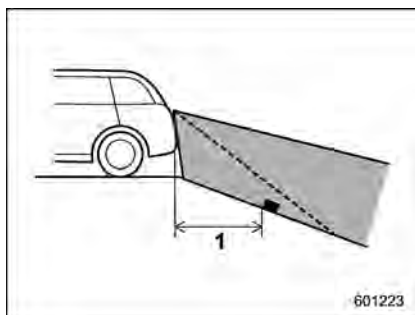

- 1) 3 feet (1 m)

The distance on the screen looks nearer than the actual distance.

NOTE

When cargo is loaded, the rear view distance on the screen looks farther than the actual distance as in an upward slope.

▼ Feature of distance marker

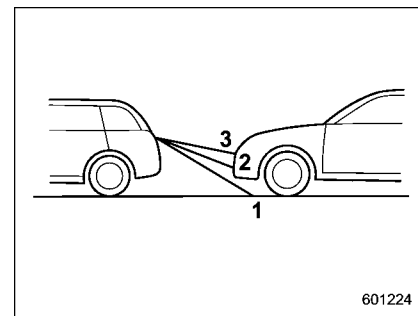

- 1) 3 feet (1 m) line
2) 6.5 feet (2 m) line
3) 10 feet (3 m) line

The distance marker shows the distance on the road. If there is a car or other object close behind, distance cannot be correctly displayed.

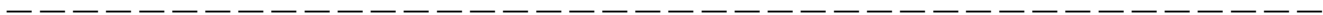
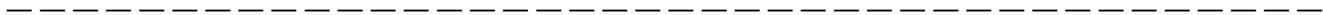
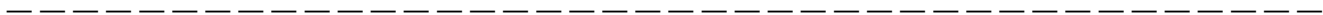
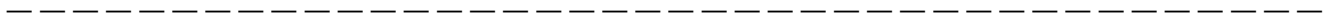
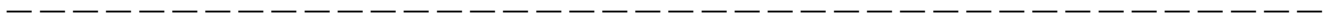
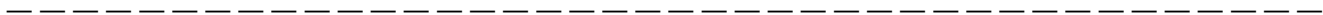
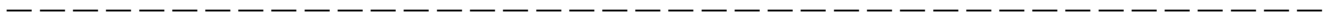
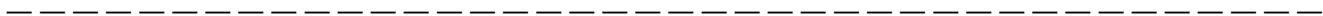
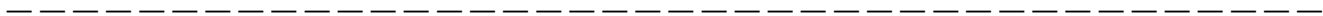
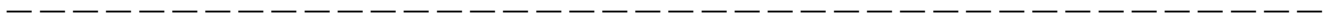
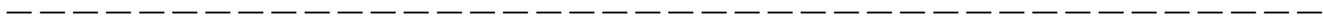
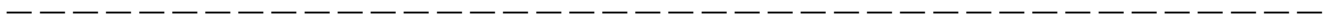

| | | | |
|---|------|--|------|
| Fuel | 7-2 | Shift lock function | 7-20 |
| Fuel requirements | 7-2 | Selection of manual mode..... | 7-21 |
| Fuel filler lid and cap..... | 7-3 | Driving tips..... | 7-23 |
| State emission testing (U.S. only)..... | 7-6 | Power steering..... | 7-23 |
| Preparing to drive | 7-7 | Braking..... | 7-23 |
| Starting the engine..... | 7-8 | Braking tips..... | 7-23 |
| MT models | 7-8 | Brake system | 7-24 |
| AT and CVT models..... | 7-9 | Disc brake pad wear warning indicators | 7-24 |
| Stopping the engine..... | 7-10 | ABS (Anti-lock Brake System)..... | 7-25 |
| Remote engine start system | | ABS system self-check | 7-25 |
| (dealer option) | 7-10 | ABS warning light..... | 7-25 |
| Starting your vehicle | 7-11 | Electronic Brake Force Distribution (EBD) | |
| Remote start safety features | 7-11 | system | 7-26 |
| Entering the vehicle while it is running via remote | | Steps to take if EBD system malfunctions | 7-27 |
| start..... | 7-12 | Vehicle Dynamics Control system..... | 7-28 |
| Remote start confirmation transmitter | | Vehicle Dynamics Control system monitor..... | 7-29 |
| feature | 7-12 | Vehicle Dynamics Control OFF switch | 7-31 |
| Entering the vehicle following remote engine start | | Tire pressure monitoring system (TPMS) | |
| shutdown..... | 7-13 | (if equipped)..... | 7-32 |
| Pre-heating or pre-cooling the interior of the | | Parking your vehicle | 7-33 |
| vehicle | 7-13 | Electronic parking brake | 7-34 |
| Service mode..... | 7-14 | Parking tips | 7-37 |
| Remote transmitter program..... | 7-14 | Cruise control | 7-38 |
| System maintenance | 7-14 | To set cruise control | 7-38 |
| Manual transmission..... | 7-16 | To temporarily cancel the cruise control..... | 7-39 |
| Selecting reverse gear..... | 7-16 | To turn off the cruise control..... | 7-39 |
| Shifting speeds | 7-17 | To change the cruising speed | 7-40 |
| Driving tips | 7-17 | Cruise control indicator light..... | 7-41 |
| Automatic transmission/Continuously | | Cruise control set indicator light | 7-41 |
| variable transmission | 7-18 | | |
| Select lever..... | 7-19 | | |

Fuel



CAUTION

Use of a fuel which is low in quality or use of an inappropriate fuel additive may cause engine damage.

■ Fuel requirements

▼ Non-turbo models

The non-turbo engine is designed to operate using **unleaded** gasoline with an octane rating of **87 AKI or higher**.

▼ Turbo models

The engine is designed to operate at maximum performance using **unleaded** gasoline with an octane rating of **93 AKI or higher**. If 93 AKI fuel is not readily available in your area, unleaded gasoline with an octane rating of 91 AKI may be used with no detriment to engine durability or driveability. However, you may notice a slight decrease in maximum engine performance while using 91 AKI fuel. Use of 91 AKI fuel will not affect your warranty coverage. If premium unleaded gasoline is not available, regular unleaded gasoline with an octane rating of 87 AKI or higher may be temporarily used. For optimum

engine performance and driveability, it is required that you use premium grade unleaded gasoline.

NOTE

Be sure to use premium unleaded gasoline of 91 AKI or higher for a turbo engine model. If other gasoline (lower than 91 AKI) is used, knocking, reduced output and poor accelerator response will result.

▼ Fuel octane rating

This octane rating is the average of the Research Octane and Motor Octane numbers and is commonly referred to as the Anti Knock Index (AKI).

Using a gasoline with a lower octane rating can cause persistent and heavy knocking, which can damage the engine. Do not be concerned if your vehicle sometimes knocks lightly when you drive up a hill or when you accelerate. See your dealer or a qualified service technician if you use a fuel with the specified octane rating and your vehicle knocks heavily or persistently.

▼ Unleaded gasoline

The neck of the fuel filler pipe is designed to accept only an unleaded gasoline filler nozzle. Under no circumstances should leaded gasoline be used because it will

damage the emission control system and may impair driveability and fuel economy.

▼ California fuel

If your vehicle was certified to California Emission Standards as indicated on the underhood tune-up label, it is designed to optimize engine and emission control system performance with gasoline that meets the clean burning low-sulfur California gasoline specifications. If you live in any other state than California, your vehicle will operate on gasoline meeting Federal specifications. Gasoline sold outside California is permitted to have higher sulfur levels, which may affect the performance of your vehicle's catalytic converter and may produce a sulfur exhaust odor or smell. SUBARU recommends that you try a different brand of unleaded gasoline having lower sulfur to determine if the problem is fuel related before returning your vehicle to an authorized dealer for service. The CHECK ENGINE warning light/malfunction indicator lamp may also turn on. If this occurs, return to your authorized SUBARU dealer for diagnosis. If it is determined that the condition is caused by the type of fuel used, repairs may not be covered by your warranty.

▼ MMT

Some gasoline contains an octane-enhancing additive called MMT (Methylcyclopentadienyl Manganese Tricarbonyl). If you use such fuels, your emission control system performance may deteriorate and the CHECK ENGINE warning light/malfunction indicator lamp may turn on. If this happens, return to your authorized SUBARU Dealer for service. If it is determined that the condition is caused by the type of fuel used, repairs may not be covered by your warranty.

▼ Gasoline for cleaner air**CAUTION**

Do not let fuel spill on the exterior surfaces of the vehicle. Fuels containing alcohol may cause paint damage, which is not covered under the SUBARU Limited Warranty.

Your use of gasoline with detergent additives will help prevent deposits from forming in your engine and fuel system. This helps keep your engine in tune and your emission control system working properly, and is a way of doing your part for cleaner air. If you continuously use a high quality fuel with the proper detergent and other additives, you should never

need to add any fuel system cleaning agents to your fuel tank.

Many gasolines are now blended with materials called oxygenates. Use of these fuels can also help keep the air cleaner. Oxygenated blend fuels, such as MTBE (Methyl Tertiary Butyl ether) or ethanol (ethyl or grain alcohol) may be used in your vehicle, but should contain no more than 15% MTBE or 10% ethanol for the proper operation of your SUBARU.

In addition, some gasoline suppliers are now producing reformulated gasolines, which are designed to reduce vehicle emissions. SUBARU approves the use of reformulated gasoline.

If you are not sure what the fuel contains, you should ask your service station operators if their gasolines contain detergents and oxygenates and if they have been reformulated to reduce vehicle emissions.

As additional guidance, only use fuels suited for your vehicle as explained in the following.

- Fuel should be unleaded and have an octane rating no lower than that specified in this manual.
- Methanol (methyl or wood alcohol) is sometimes mixed with unleaded gasoline.

Methanol can be used in your vehicle **ONLY** if it does not exceed 5% of the fuel mixture **AND** if it is accompanied by sufficient quantities of the proper cosolvents and corrosion inhibitors required to prevent damage to the fuel system. Do not use fuel containing methanol **EXCEPT** under these conditions.

- If undesirable driveability problems are experienced and you suspect they may be fuel related, try a different brand of gasoline before seeking service at your SUBARU dealer.
- Fuel system damage or driveability problems which result from the use of improper fuel are not covered under the SUBARU Limited Warranty.

■ Fuel filler lid and cap**▼ Refueling**

Only one person should be involved in refueling. Do not allow others to approach the area of the vehicle near the fuel filler pipe while refueling is in progress.

Be sure to observe any other precautions that are posted at the service station.

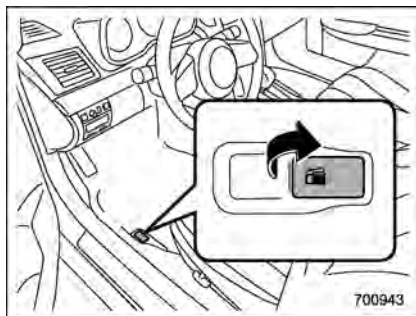

1. To open the fuel filler lid, pull the lid release lever up. The lever is on the floor at the left of the driver's seat.

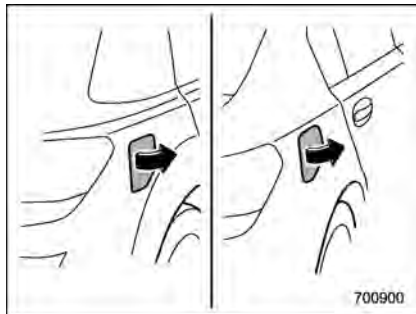

2. Open the fuel filler lid.

⚠ WARNING

Before opening the fuel filler cap, first touch the vehicle body or a metal portion of the fuel pump or similar object to discharge any static electricity that may be present on your body. If your body is carrying an electrostatic charge, there is a possibility that an electric spark could ignite the fuel, which could burn you. To avoid acquiring a new static electric charge, do not get back into the vehicle while refueling is in progress.

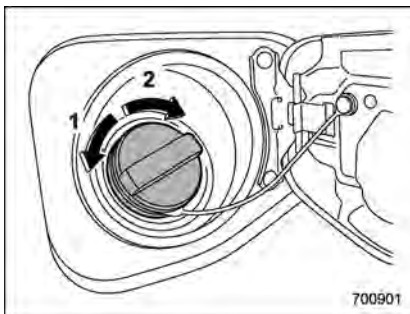

- 1) Open
- 2) Close

3. Remove the fuel filler cap by turning it

slowly counterclockwise.

⚠ WARNING

- Gasoline vapor is highly flammable. Before refueling, always first stop the engine and close all vehicle doors and windows. Make sure that there are no lighted cigarettes, open flames or electrical sparks in the adjacent area. Refueling must be performed outside. Quickly wipe up any spilled fuel.
- When opening the cap, grasp it firmly and turn it slowly to the left. Do not remove the cap quickly. Fuel may be under pressure and spray out of the fuel filler neck, especially in hot weather. If you hear a hissing sound while you are removing the cap, wait for the sound to stop and then slowly open the cap to prevent fuel from spraying out and creating a fire hazard.

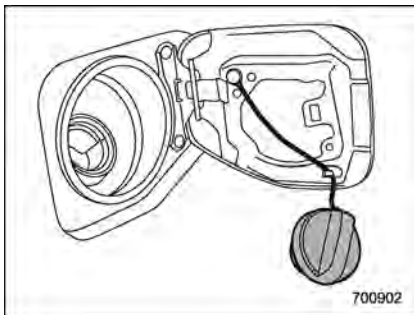

4. Hook the cord that is attached to the fuel filler cap onto the hook inside the fuel filler lid.

WARNING

- When refueling, insert the fuel nozzle securely into the fuel filler pipe. If the nozzle is lifted or not fully inserted, its automatic stopping mechanism may not function, causing fuel to overflow the tank and creating a fire hazard.
- Stop refueling when the automatic stop mechanism on the fuel nozzle activates. If you continue to add fuel, temperature changes or other conditions may cause fuel to overflow from

the tank and create a fire hazard.

5. Stop filling the tank after the fuel filler pump automatically turns off. Do not add any more fuel.

CAUTION



Make sure that the cap is tightened until it clicks to prevent fuel spillage in the event of an accident.

6. Put the cap back on, turn it clockwise until you hear a clicking noise. Be certain not to catch the tether under the cap while tightening.

7. Close the fuel filler lid completely. If you spill any fuel on the painted surface, rinse it off immediately. Otherwise, the painted surface could be damaged.

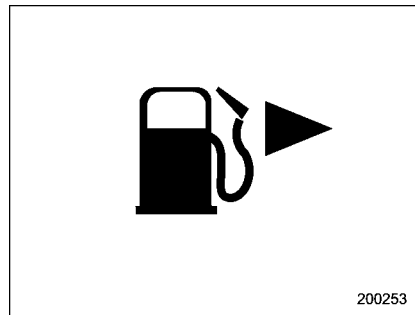
NOTE



- You will see the “” sign in the fuel gauge. This indicates that the fuel filler door (lid) is located on the right side of the vehicle.
- If the fuel filler cap is not tightened until it clicks or if the tether is caught under the cap, the CHECK ENGINE warning light/malfunction indicator lamp may illuminate. Refer to “CHECK ENGINE warning light/Malfunction indicator lamp”  3-12.

CAUTION

- Never add any cleaning agents to the fuel tank. The addition of a cleaning agent may cause da-

mage to the fuel system.

- After refueling, turn the cap to the right until it clicks to ensure that it is fully tightened. If the cap is not securely tightened, fuel may leak out while the vehicle is being driven or fuel spillage could occur in the event of an accident, creating a fire hazard.
- Do not let fuel spill on the exterior surfaces of the vehicle. Because fuel may damage the paint, be sure to wipe off any spilled fuel quickly. Paint damage caused by spilled fuel is not covered under the SUBARU Limited Warranty.
- Always use a genuine SUBARU fuel filler cap. If you use the wrong cap, it may not fit, and your fuel tank and emission control system may be damaged. It could also lead to fuel spillage and a fire.
- Immediately put fuel in the tank whenever the low fuel warning light illuminates. Engine misfires as a result of an empty tank could cause damage to the engine.

State emission testing (U.S. only)

WARNING

Testing of an All-Wheel Drive vehicle must **NEVER** be performed on a single two-wheel dynamometer. Attempting to do so will result in uncontrolled vehicle movement and may cause an accident or injuries to persons nearby.

CAUTION

Resultant vehicle damage due to improper testing is not covered under the SUBARU Limited Warranty and is the responsibility of the state inspection program or its contractors or licensees.

At state inspection time, remember to tell your inspection or service station in advance not to place your SUBARU AWD vehicle on a two-wheel dynamometer. Otherwise, serious transmission damage will result.

Some states have started using dynamometers in their state inspection programs

in order to meet their obligation under federal law to implement stricter vehicle emission standards to reduce air pollution from vehicles. A dynamometer is a treadmill or roller-like testing device that allows your vehicle's wheels to turn while the vehicle remains in one place. Depending on the severity of a state's air pollution problems, the states must adopt either a "basic" or "enhanced" vehicle emission inspection test. Normally, a portion of the basic emission test consists of an emission inspector inserting an analyzer probe into the exhaust pipe of an idling vehicle for a short period of time. States with more severe air pollution problems are required to adopt an enhanced vehicle emission test. This test simulates actual driving conditions on a dynamometer and permits more accurate measurement of tailpipe emitted pollution than the basic emission test.

The U.S. Environmental Protection Agency (EPA) and states using two-wheel dynamometers in their emission testing programs have **EXEMPTED** SUBARU AWD vehicles from the portion of the testing program that involves a two-wheel dynamometer.

There are some states that use four-wheel dynamometers in their testing programs. When properly used, that equipment will

not damage an AWD SUBARU vehicle. Under no circumstances should the rear wheels be jacked off the ground, nor should the driveshaft be disconnected for state emission testing.

The EPA has issued regulations for inspecting the On-Board Diagnostic (OBD) system as part of the state emissions inspection. The OBD system is designed to detect engine and transmission problems that might cause vehicle emissions to exceed allowable limits. These inspections apply to all 1996 model year and newer passenger cars and light trucks. Over 30 states plus the District of Columbia have implemented the OBD system inspection.

- The inspection of the OBD system consists of a visual operational check of the **"CHECK ENGINE"** warning light/malfunction indicator lamp (MIL) and an examination of the OBD system with an electronic scan tool while the engine is running.
- A vehicle passes the OBD system inspection if proper the **"CHECK ENGINE"** warning light/MIL illumination is observed, there is **no** stored diagnostic trouble codes, and the OBD system readiness monitors are complete.
- A vehicle fails the OBD inspection if the **"CHECK ENGINE"** warning light/MIL is

not properly operating or there is one or more diagnostic trouble codes stored in vehicle's computer with the **"CHECK ENGINE"** warning light/MIL illuminated.

- A state emission inspection may reject (not pass or fail) a vehicle if the number of OBD system readiness monitors **"Not Ready"** is greater than one. Under this condition, the vehicle operator should be instructed to drive his/her vehicle for a few days to set the monitors and return for an emission re-inspection.
- Owners of rejected or failing vehicles should contact their SUBARU Dealer for service.

Preparing to drive

You should perform the following checks and adjustments every day before you start driving.

1. Check that all windows, mirrors, and lights are clean and unobstructed.
2. Check the appearance and condition of the tires. Also check tires for proper inflation.
3. Look under the vehicle for any sign of leaks.
4. Check that the hood, trunk (Legacy) and rear gate (Outback) are fully closed.
5. Check the adjustment of the seat.
6. Check the adjustment of the inside and outside mirrors.
7. Fasten your seatbelt. Check that your passengers have fastened their seatbelts.
8. Check the operation of the warning and indicator lights when the ignition switch is turned to the "ON" position.
9. Check the gauges, indicator and warning lights after starting the engine.

NOTE

Engine oil, engine coolant, brake fluid, washer fluid and other fluid levels should be checked daily, weekly or at fuel stops.

Starting the engine

■ MT models

1. Apply the parking brake.
2. Turn off unnecessary lights and accessories.
3. Depress the clutch pedal to the floor and shift the shift lever into neutral. Hold the clutch pedal to the floor while starting the engine. The starter motor will only operate when the clutch pedal is depressed fully to the floor.
4. Turn the ignition switch to the "ON" position and check the operation of the warning and indicator lights. Refer to "Warning and indicator lights" 3-9.



Do not operate the starter motor continuously for more than 10 seconds. If the engine fails to start after operating the starter for 5 to 10 seconds, wait for 10 seconds or more before trying again.

5. Turn the ignition switch to the "START" position **without** depressing the accelerator pedal. Release the key immediately after the engine has started.
If the engine does not start, perform the following procedure.

(1) Turn the ignition switch to the "LOCK" position and wait for at least 10 seconds. After checking that the parking brake is firmly applied, turn the ignition switch to the "START" position while depressing the accelerator pedal slightly (approximately a quarter of the full stroke). Release the accelerator pedal as soon as the engine starts.

(2) If this fails to start the engine, turn the ignition switch back to the "LOCK" position and wait for at least 10 seconds. Then fully depress the accelerator pedal and turn the ignition switch to the "START" position. If the engine starts, quickly release the accelerator pedal.

(3) If this does not start the engine, turn the ignition switch again to the "LOCK" position. After waiting for 10 seconds or longer, turn the ignition switch to the "START" position without depressing the accelerator pedal.

(4) If the engine still refuses to start, contact your nearest SUBARU dealer for assistance.

6. Confirm that all warning and indicator lights have turned off after the engine has started. The fuel injection system automatically lowers the idle speed as the engine warms up.

NOTE (2.5 L non-turbo models)

To protect the engine while the shift lever is in the neutral position, the engine is controlled so that the engine speed may not become too high even if the accelerator pedal is depressed hard.

■ AT and CVT models

CAUTION

If you restart the engine while the vehicle is moving, shift the select lever into the "N" position. Do not attempt to place the select lever of a moving vehicle into the "P" position.

1. Apply the parking brake.
2. Turn off unnecessary lights and accessories.
3. Shift the select lever to the "P" or "N" position (preferably "P" position). The starter will only operate when the select lever is at the "P" or "N" position.

4. Turn the ignition switch to the "ON" position and check the operation of the warning and indicator lights. Refer to "Warning and indicator lights" 3-9.

CAUTION

Do not operate the starter motor continuously for more than 10 seconds. If the engine fails to start after operating the starter for 5 to 10 seconds, wait for 10 seconds or more before trying again.

5. Turn the ignition switch to the "START" position **without** depressing the accelerator pedal. Release the key immediately after the engine has started.

If the engine does not start, perform the following procedure.

- (1) Turn the ignition switch to the "LOCK" position and wait for at least 10 seconds. After checking that the parking brake is firmly applied, turn the ignition switch to the "START" position while depressing the accelerator pedal slightly (approximately a quarter of the full stroke). Release the accelerator pedal as soon as the engine starts.
- (2) If this fails to start the engine, turn the ignition switch back to the "LOCK" position and wait for at least 10

seconds. Then fully depress the accelerator pedal and turn the ignition switch to the "START" position. If the engine starts, quickly release the accelerator pedal.

(3) If this fails to start the engine, turn the ignition switch again to the "LOCK" position. After waiting for 10 seconds or longer, turn the ignition switch to the "START" position without depressing the accelerator pedal.

(4) If the engine still refuses to start, contact your nearest SUBARU dealer for assistance.

6. Confirm that all warning and indicator lights have turned off after the engine has started. The fuel injection system automatically lowers the idle speed as the engine warms up.

While the engine is warming up, make sure that the select lever is at the "P" or "N" position and that the parking brake is applied.

NOTE (2.5 L non-turbo and 3.6 L models)

To protect the engine while the select lever is in the "P" or "N" position, the engine is controlled so that the engine speed may not become too high even if the accelerator pedal is depressed

hard.

Stopping the engine



WARNING

Do not stop the engine when the vehicle is moving. This will cause loss of power to the power steering and the brake booster, making steering and braking more difficult. It could also result in accidental activation of the "LOCK" position on the ignition switch, causing the steering wheel to lock.

The ignition switch should be turned off only when the vehicle is stopped and the engine is idling.

Remote engine start system (dealer option)



WARNING

- Do not remote start a vehicle in an enclosed environment (e.g. closed garage). Prolonged operation of a motor vehicle in an enclosed environment can cause a harmful build-up of Carbon Monoxide. Carbon Monoxide is harmful to your health. Exposure to high levels of Carbon Monoxide can cause headaches, dizziness or in extreme cases unconsciousness and/or death.
- Before performing any servicing of the vehicle, temporarily place the remote engine start system in service mode to prevent the system from unexpectedly starting the engine.

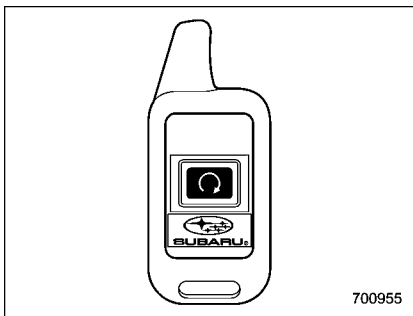

■ Starting your vehicle

NOTE

All vehicle doors, the engine hood and trunk / rear gate must be closed prior to activating the remote engine start system. Any open entry point will prevent starting or cause the system to shut down.

The remote engine start function is activated by pressing the "⌚" button twice within 3 seconds on your remote engine start transmitter. Upon successful activation the remote start confirming transmitter button will flash once* and the vehicle will honk the horn and flash the side marker lights, tail lights and front position lights once. The system will check certain

preconditions before starting, and if all safety parameters are correct, the engine will start within 5 seconds. Upon successful engine start, the remote start confirmation transmitter button will flash twice every 5 seconds* and the vehicle will honk the horn and flash the side marker lights, tail lights and the front position lights once, then the lights will illuminate and remain illuminated, indicating that the engine is running. While the vehicle is operating via the remote engine start function, the power window features will be disabled. Also, the system has a timer and will shut down after 15 minutes if you do not operate the vehicle. Press and hold the "⌚" button for 2 seconds to turn the engine off. The remote start confirmation transmitter button will flash three times* indicating that the engine has shut down. If the starter cranks but does not start or starts and stalls, the remote engine start system will power off and then attempt to start the engine an additional three times unless the remote engine start system determines that a vehicle malfunction is preventing the system from starting. If the engine does not start after additional attempts, the remote engine start system will abort and return to a non-activate state.

*: Provided that the remote engine start

transmitter is within the operating range of the system.

■ Remote start safety features

For safety and security reasons, the system will fail to start and honk the horn twice or shut down the engine during remote start operation if any of the following occur:

- Any of the doors or the trunk / rear gate are open / opened (*the vehicle's horn will honk six times and the side marker lights, tail lights and the front position lights will flash six times indicating that a vehicle door or trunk / rear gate was open when the remote engine start system was activated).
- The brake pedal is depressed
- The key was already in the ignition switch
- The engine hood is opened
- The remote start system "Service mode" is engaged
- The vehicle's engine idle speed has reached a level over 3,500 RPM
- The alarm is triggered by opening a door or the rear gate.
- The select lever is not in the "P" position (AT and CVT models)

In addition to the items above, if the

vehicle's engine management system determines there is a safety risk due to a vehicle related problem, the vehicle will shut down and the vehicle's horn will honk three times.

NOTE

- If the alarm system is armed at the time of remote engine start activation (the security indicator light on the combination meter is flashing), the alarm system will remain armed throughout the remote start run cycle.
- If the alarm system is disarmed at the time of remote engine start activation (the security indicator light on the combination meter is not flashing), the alarm system will remain disarmed throughout the remote start run cycle.

■ Entering the vehicle while it is running via remote start

1. Unlock the vehicle doors using the remote keyless entry system. If the vehicle's doors are unlocked manually using the key, the vehicle's alarm system will trigger (if the alarm system is armed prior to activating the remote engine start system) and the engine will turn off. Inserting the key into the ignition switch and turning it to the "ON" position or pressing the unlock button  on the

remote keyless entry transmitter will disarm the alarm system. Refer to "Alarm system"  2-16.

2. Enter the vehicle.
3. The engine will shut down when any door or trunk/rear gate is opened.
4. Insert the key into the ignition switch and turn to the "START" position to restart the engine.

■ Remote start confirmation transmitter feature

Your remote engine start transmitter is equipped with a unique bidirectional confirmation feature. This feature will allow the transmitter's backlit button to display the status of the system under the condition that the vehicle and transmitter are within the operational range of the system. Typical transmitter button flash sequences are outlined in the following chart.

| Transmitter flash sequence | Feature description |
|---|---|
| Flashes when button is pressed | Indicates that the system is transmitting an RF signal. |
| Two long flashes following remote start activation (transmitter button is pressed two times within 3 seconds) | Indicates that the transmitter did not receive the remote start activation confirmation from the vehicle system. The transmitter will automatically send one additional remote start activation attempt. This usually occurs when the operational range is at its limit or has been exceeded. |
| One flash following remote start activation (transmitter button is pressed two times within 3 seconds) | Indicates that the engine is running via remote start. If the transmitter is moved outside of the operating range of the system, this sequence will timeout after the normal 15-minute vehicle run cycle. |
| 2 flashes every 5 seconds | Indicates that the engine is running via remote start. If the transmitter is removed outside of the operating range of the system, this sequence will timeout after the normal 15-minute vehicle run cycle. |
| 3 flashes | Indicates that the engine has turned off due to a remote start system 15-minute timeout, vehicle safety parameter or normal shutdown. |

■ Entering the vehicle following remote engine start shutdown

An alarm trigger may occur if the vehicle is opened by the remote keyless entry transmitter within a few seconds immediately following remote engine start shutdown.

■ Pre-heating or pre-cooling the interior of the vehicle

Models with automatic climate control system:

After the system starts the engine, the automatic climate control system will activate the "FULL AUTO" mode and heat or cool the interior to the predetermined median (room) temperature. No pre-setting of controls is necessary.

Models with manual climate control system:

Before exiting the vehicle, set the temperature controls to the desired setting and operation. After the system starts the engine, the heater or air conditioning will activate and heat or cool the interior to your setting.

■ Service mode

In service mode, the remote engine start function is temporarily disabled to prevent the system from unexpectedly starting the engine while being serviced.

To engage or disengage service mode:

1. Enter the vehicle and close all vehicle doors and the trunk/rear gate.
2. Verify that the select lever is in the "P" position (AT and CVT models)
3. Depress and hold the brake pedal
4. Turn the ignition switch to the "ON" position
5. Press and release the remote engine start transmitter "Q" button three times. The system will honk the vehicle's horn each time the button is pressed.
6. The system will pause for 1 second then honk the vehicle's horn three times to indicate that the service mode has been engaged or honk one time to indicate that the service mode has been disengaged.

NOTE

When taking your vehicle in for service, it is recommended that you inform the service personnel that your vehicle is equipped with a remote engine start system.

■ Remote transmitter program

New transmitters can be programmed to the remote engine start system in the event that a transmitter is lost, stolen, damaged or additional transmitters are desired (the system will accept up to eight transmitters). New remote engine start transmitters can be programmed according to the following procedure.

1. Open the driver's door (the driver's door must remain opened throughout the entire process).
2. Depress and hold the brake pedal.
3. Turn the ignition switch to "ON" then "LOCK", back to "ON" then "LOCK", then back to "ON" again and leave the ignition "ON" throughout the programming process.
4. The system will flash the side marker lights, tail lights and front position lights and honk the horn three times, indicating that the system has entered the transmitter learn mode.
5. Press and release the "Q" button on the transmitter that you want to program.
6. The system will flash the side marker lights, tail lights and front position lights and honk the horn one time, indicating that the system has learned the transmitter. Upon successful programming, the remote start confirmation transmitter button

will flash one time.

7. Repeat step 5 for any additional transmitters (the system will accept up to eight transmitters).

8. The system will exit the transmitter learn mode if the key is turned to the "LOCK" position, the door is closed or after 2 minutes.

■ System maintenance

NOTE

In the event that the vehicle's battery is replaced, discharged or disconnected, it will be necessary to start the vehicle a minimum of one time using the key prior to activating the remote engine start system. This is required to allow the vehicle electronic systems to re-synchronize.

▼ Changing the batteries



CAUTION

- Do not let dust, oil or water get on or in the remote engine start transmitter when replacing the battery.
- Be careful not to damage the printed circuit board in the remote engine start transmitter when replacing the battery.

- Be careful not to allow children to touch the battery and any removed parts; children could swallow them.
- There is a danger of explosion if an incorrect replacement battery is used. Replace only with the same or equivalent type of battery.
- Batteries should not be exposed to excessive heat such as sunshine, fire or the like.

The two 3-volt lithium batteries (model CR-2032) supplied in your remote engine start transmitter should last approximately one year, depending on usage. When the batteries begin to weaken, you will notice a decrease in range (distance from the vehicle that your remote control operates). Follow the instructions below to change the remote engine start transmitter batteries.

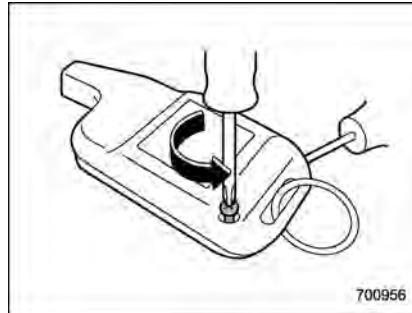

1. Remove the small Phillips screw located on the back side lower left corner of the transmitter.
2. Carefully pry the remote engine start transmitter halves apart using a small flat-head screwdriver.

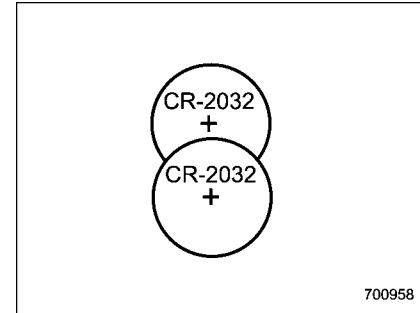
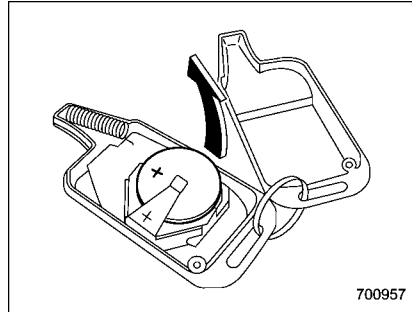

3. Remove the circuit board from the bottom half of the case and remove the batteries and replace with new ones. Be sure to observe the (+) sign on the old batteries before removing them to ensure that the new batteries are inserted properly (battery "+" should be pointed away from the transmitter circuit board on both batteries).
4. Carefully snap the case halves back together, reinstall the Phillips screw and test the remote engine start system.

NOTE

- This device complies with Part 15 of the FCC Rules and with RSS-210 of Industry Canada. Operation is subject to the following two conditions: (1) This device may not cause harmful inter-

ference, and (2) this device must accept any interference received, including interference that may cause undesired operation.

Changes or modifications not expressly approved by the party responsible for compliance could void the user's authority to operate the equipment and void warranty.

- To comply with the FCC RF exposure compliance requirements, no change to the antenna or the device is permitted. Any change to the antenna or the device could result in the device exceeding the RF exposure requirements and void user's authority to operate the device.

Manual transmission

WARNING

Do not drive the vehicle with the clutch disengaged (i.e., when the clutch pedal is depressed) or with the shift lever in the neutral position. Engine braking has no effect in either of these conditions and the risk of an accident is consequently increased.

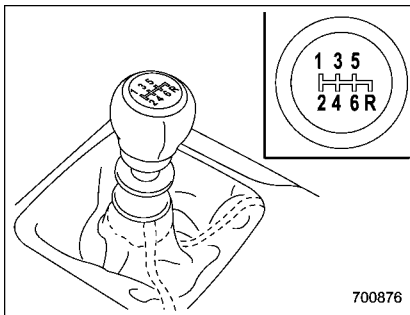

The manual transmission is a fully synchromeshed, 6-forward-speed and 1-reverse-speed transmission.

The shift pattern is shown on the shift lever knob.

■ Selecting reverse gear

CAUTION

Shift into reverse **ONLY** when the vehicle has completely stopped. It may cause damage to the transmission to try shifting into reverse when the vehicle is moving.

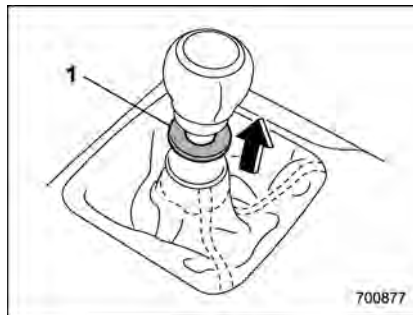

1) Slider

You must raise the slider and hold it in that position before you can move the shift lever to the "R" position.

To change gears, fully depress the clutch pedal, move the shift lever, and gradually let up on the clutch pedal.

If it is difficult to shift into gear, put the

transmission in neutral, release the clutch pedal momentarily, and then try again.

■ Shifting speeds

▼ Recommended shifting speeds

The best compromise between fuel economy and vehicle performance during normal driving is ensured by shifting up at the speeds listed in the following table.

| Shift up | mph (km/h) |
|------------|------------|
| 1st to 2nd | 15 (24) |
| 2nd to 3rd | 25 (40) |
| 3rd to 4th | 40 (64) |
| 4th to 5th | 45 (72) |
| 5th to 6th | 50 (80) |

▼ Maximum allowable speeds



WARNING

When shifting down a gear, ensure that the vehicle is not travelling at a speed exceeding the Maximum Allowable Speed for the gear which is about to be selected. Failure to observe this precaution can lead to engine over-revving and this in turn can result in engine damage.

In addition, sudden application of

engine brakes when the vehicle is travelling on a slippery surface can lead to wheel locking; as a consequence, control of the vehicle may be lost and the risk of an accident increased.

The following table shows the maximum speeds that are possible with each different gear. The tachometer's needle will enter the red area if these speeds are exceeded.

With the exception of cases where sudden acceleration is required, the vehicle should not be driven with the tachometer's needle inside the red area. Failure to observe this precaution can lead to excessive engine wear and poor fuel economy.

| Gear | Legacy | | Outback |
|------|------------------|--------------|-----------|
| | Non-turbo models | Turbo models | |
| 1st | 32 (52) | 35 (56) | 32 (52) |
| 2nd | 57 (92) | 62 (100) | 57 (92) |
| 3rd | 86 (139) | 94 (151) | 86 (139) |
| 4th | 114 (184) | 125 (201) | 115 (185) |

NOTE

Never exceed posted speed limits.

■ Driving tips

Do not drive with your foot resting on the clutch pedal and do not use the clutch to hold your vehicle at a standstill on an upgrade. Either of those actions may cause clutch damage.

Do not drive with your hand resting on the shift lever. This may cause wear on the transmission components.

When it is necessary to reduce vehicle speed due to slow traffic, turning corners, or driving up steep hills, downshift to a lower gear before the engine starts to labor.

On steep downgrades, downshift the transmission to 5th, 4th, 3rd or 2nd gear as necessary; this helps to maintain a safe speed and to extend brake pad life.

In this way, the engine provides a braking effect. Remember, if you "ride" (over use) the brakes while descending a hill, they may overheat and not work properly.

The engine may, on rare occasions, knock when the vehicle rapidly accelerates or rapidly pulls away from a standstill. This phenomenon does not indicate a problem.

Automatic transmission/Continuously variable transmission

The automatic transmission is electronically controlled and provides 5 forward speeds and 1 reverse speed. The continuously variable transmission is electronically controlled and provides an infinite number of forward speeds and 1 reverse speed.

Both the automatic transmission and continuously variable transmission have a manual mode.



WARNING

Do not shift from the “P” or “N” position into the “D” or “R” position while depressing the accelerator pedal. This may cause the vehicle to jump forward or backward.



CAUTION

- Shift into the “P” or “R” position only after the vehicle is completely stopped. Shifting while the vehicle is moving may cause damage to the transmission.
- Do not race the engine for more

than 5 seconds in any position except the “N” or “P” position when the brake is applied or when chocks are used in the wheels. This may cause the transmission fluid to overheat.

- Avoid shifting from one of the forward driving positions into the “R” position or vice versa until the vehicle has completely stopped. Such shifting may cause damage to the transmission.
- When parking the vehicle, first securely apply the parking brake and then place the select lever in the “P” position. Avoid parking for a long time with the select lever in any other position as doing so could result in a dead battery.

NOTE

- For AT models, when the engine coolant temperature is still low, the transmission will upshift to higher engine speeds than when the coolant temperature is sufficiently high in order to shorten the warm-up time and improve driveability. The gearshift timing will automatically shift to the nor-

mal timing after the engine has warmed up.

- Immediately after transmission fluid is replaced, you may feel that the transmission operation is somewhat unusual. This results from invalidation of data which the on-board computer has collected and stored in memory to allow the transmission to shift at the most appropriate times for the current condition of your vehicle. Optimized shifting will be restored as the vehicle continues to be driven for a while.
- When driving a vehicle that is equipped with CVT under continuous heavy load conditions such as towing a camper or climbing a long, steep hill, the engine speed or the vehicle speed may automatically be reduced. This is not a malfunction. This phenomenon results from the engine control function maintaining the cooling performance of the vehicle. The engine and vehicle speed will return to a normal speed when the engine is able to maintain the optimum cooling performance after the heavy load decreases. Driving under a heavy load must be performed with extreme care. Do not try to pass a vehicle in front when driving on an uphill slope while towing.
- The continuously variable transmission is a chain type system that

provides superior transmission efficiency for maximum fuel economy. At times, depending on varying driving conditions, a chain operating sound may be heard that is characteristic of this type of system.

■ Select lever

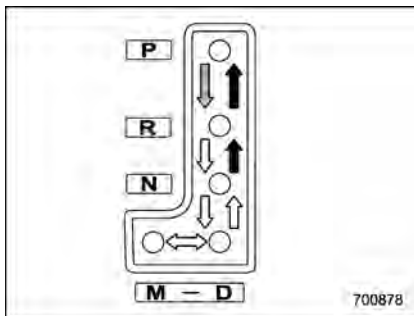

- ➡ : With the brake pedal depressed, shift while pressing the button in
- ➡ : Shift while pressing the button in
- ↔ : Shift without pressing the button

The select lever has four positions, "P", "R", "N", "D" and also has a manual gate for using the manual mode.

▼ P (Park)

This position is for parking the vehicle and starting the engine.

In this position, the transmission is mechanically locked to prevent the vehicle from rolling freely.

When you park the vehicle, first apply the parking brake fully, then shift into the "P" position. Do not hold the vehicle with only the transmission.

To shift the select lever from the "P" to any other position, you should depress the brake pedal fully then move the select lever. This prevents the vehicle from lurching when it is started.

NOTE

To protect the engine while the "P" position is selected, the engine is controlled such that the engine speed may not become too high even if the accelerator pedal is depressed hard.

▼ R (Reverse)

This position is for backing the vehicle.

To shift from the "N" to "R" position, stop the vehicle completely then move the lever to the "R" position.

▼ N (Neutral)

This position is for restarting a stalled engine.

In this position the wheels and transmission are not locked. In this position, the

transmission is neutral; the vehicle will roll freely, even on the slightest incline unless the parking brake or foot brake is applied. Avoid coasting with the transmission neutral.

During coasting, there is no engine braking effect.

NOTE

- To protect the engine while the "N" position is selected, the engine is controlled such that the engine speed may not become too high even if the accelerator pedal is depressed hard.
- If the select lever is in the "N" position when you stop the engine for parking, you may not subsequently be able to move it to the "R" and "P" positions. If this happens, turn the ignition switch to the "ON" position. You will then be able to move the select lever to the "P" position.



WARNING

Do not drive the vehicle with the select lever in the "N" (neutral) position. Engine braking has no effect in this condition and the risk of an accident is consequently increased.

▼ D (Drive)

This position is for normal driving. The transmission automatically shifts into a suitable gear according to the vehicle speed and the acceleration you require.

When more acceleration is required in this position, depress the accelerator pedal fully to the floor and hold that position. The transmission will automatically downshift. When you release the pedal, the transmission will return to the original gear position.

To use the manual mode, move the lever from this position into the manual gate.

NOTE (AT models only)

Automatic downshifts to 4th or 3rd may occur even when driving on a level road depending on conditions, such as how hard you depress the brake pedal.

▽ While climbing a grade

When driving up a hill, undesired upshift is prevented from taking place when the accelerator is released. This minimizes the chance of subsequent downshifting to a lower gear when accelerating again. This prevents repeated upshifting and downshifting resulting in a smoother operation of the vehicle.

NOTE

The transmission may downshift, depending on the way the accelerator pedal is depressed to accelerate the vehicle again.

■ Shift lock function

The shift lock function helps prevent the improper operation of the select lever.

- The select lever cannot be operated unless the ignition switch is turned to the "ON" position and the brake pedal is depressed.
- The select lever cannot be moved from the "P" position to any other position before the brake pedal is depressed. Depress the brake pedal first, and then operate the select lever.
- Only the "P" position allows you to turn the key from the "Acc" position to the "LOCK" position and remove the key from the ignition key cylinder.
- If the ignition switch is turned to the "LOCK" position while the select lever is in the "N" position, the select lever may not be moved to the "P" position after a period of time. Therefore, move the select lever to the "P" position with the brake pedal depressed soon after the ignition switch is turned to the "LOCK" position.

▼ Shift lock release

If the select lever cannot be operated, turn the ignition switch back to the "ON" position then move the select lever to the "P" position with the select lever button pressed and brake pedal depressed.

If the select lever does not move after performing the above procedure, perform the following steps.

- **When the select lever cannot be shifted from "P" to "N":**

Refer to "Shift lock release using the shift lock release button" φ 7-21.

- **When the select lever cannot be shifted from "N" to "R", "P":**

Within 60 seconds after placing the ignition switch in the "Acc" position, move the select lever to the "P" position with the select lever button pressed and brake pedal depressed.

If you must perform the above procedure, the shift lock system (or the vehicle control system) may be malfunctioning. Contact a SUBARU dealer for an inspection as soon as possible.

If the select lever does not move after performing the above procedure, refer to "Shift lock release using the shift lock release button" φ 7-21.

▼ Shift lock release using the shift lock release button

Perform the following procedure to release the shift lock.

1. Apply the parking brake and stop the engine.

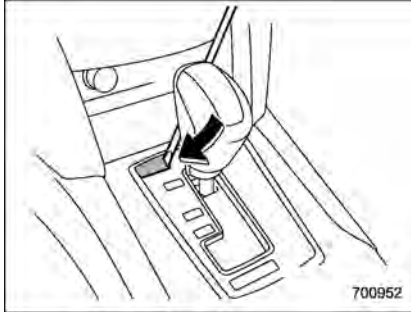

2. Remove the shift lock cover using a flat-head screwdriver.

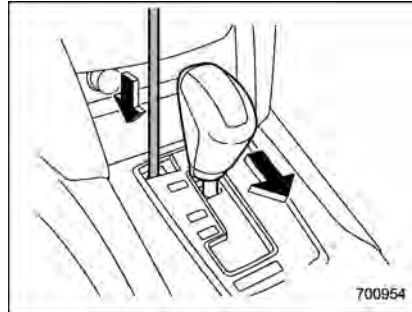

3. While depressing the brake pedal, insert the electronic parking brake release tool into the hole, press the shift lock release button using the tool, and then move the select lever.

NOTE

To prevent damage to the shift lock cover, cover the tip of the flat-head screwdriver with vinyl tape or a cloth before removing the cover.

If the select lever does not move after performing the above procedure, the shift lock system may be malfunctioning. Contact a SUBARU dealer for an inspection as soon as possible.

■ Selection of manual mode

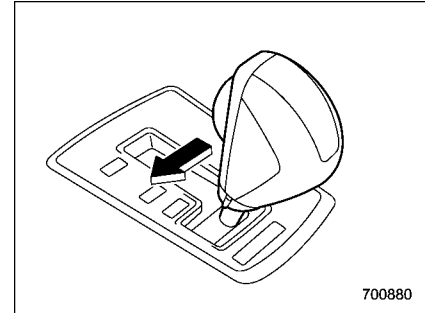

With the vehicle either moving or stationary, move the select lever from the "D" position to the "M" position to select the manual mode.

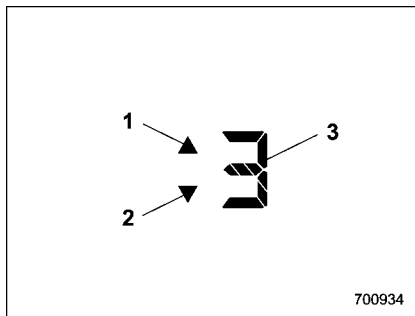

- 1) Upshift indicator
- 2) Downshift indicator
- 3) Gear position indicator

When the manual mode is selected, the gear position indicator and upshift indicator and/or downshift indicator on the combination meter illuminate. The gear position indicator shows the currently selected gear in the 1st-to-5th-gear range (AT models) or 1st-to-6th gear range (CVT models). The upshift and downshift indicators show when a gearshift is possible. When the upshift indicator “ \triangle ” is on, upshifting is possible. When the downshift indicator “ ∇ ” is on, downshifting is possible. When both indicators are on, upshifting and downshifting are both possible. When the vehicle stops (for example, at traffic signals), the downshift indicator

turns off.

Gearshifts can be performed using the paddle shift switch behind the steering wheel.

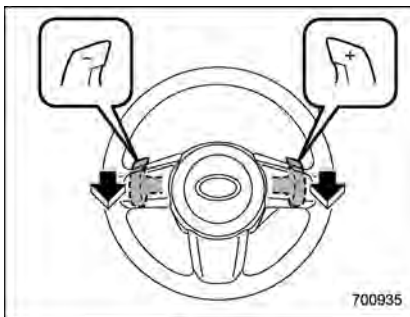

Pull the “+” of the paddle shift to upshift one level. Also pull the “-” of the paddle shift to downshift one level.

To deselect the manual mode, return the select lever to the “D” position from the “M” position.

While driving with the select lever in the “D” position, if you change gears by paddle shifting, the gear position indicator light illuminates and shows the current gear condition.



CAUTION

Do not place or hang anything on the paddle shift levers. Doing so may result in accidental gear shifting.

NOTE

Please read the following points carefully and bear them in mind when using the manual mode.

- If you attempt to shift down when the engine speed is too high, i.e., when a downshift would push the tachometer needle beyond the red zone, beeps will be emitted to warn you that the downshift is not possible.
- If you attempt to shift up when the vehicle speed is too low, the transmission will not respond.
- You can perform a skip-shift (for example, from 4th to 2nd) by operating the paddle switch twice in rapid succession.
- The transmission automatically selects 1st gear when the vehicle stops moving.
- If the temperature of the transmission fluid becomes too high, the “AT OIL TEMP” warning light will illuminate. Immediately stop the vehicle in a safe

place and let the engine idle until the warning light turns off.

■ Driving tips

- On a road surface where there is a risk of wheelspin (for example, a snow- or gravel-covered road), you can pull away from a standstill safely and easily by first selecting the 2nd gear of the manual mode.
- Always apply the foot or parking brake when the vehicle is stopped in the “D” or “R” position.
- Always apply the parking brake when parking your vehicle. Do not hold the vehicle with only the transmission.
- Do not keep the vehicle in a stationary position on an uphill grade by using the “D” position. Use the brake instead.
- The engine may, on rare occasions, knock when the vehicle rapidly accelerates or rapidly pulls away from a standstill. This phenomenon does not indicate a fault.
- A slight reduction in output torque may occur in the models with a 2.5 L turbo or 3.6 L engine before the engine warms up.

Power steering

CAUTION

Do not hold the steering wheel at the fully locked position left or right for more than 5 seconds. This may damage the power steering pump.

The power steering system operates only when the engine is running.

If you lose power steering assist because the engine stops or the system fails to function, you can steer but it will take much more effort.

NOTE

Right after the engine has been started and before it has warmed up, you may hear a noise coming from areas adjacent to the power steering pump which is located at the right-front area of the engine compartment. This noise is normal. It does not indicate power steering system trouble.

Braking

■ Braking tips

WARNING

Never rest your foot on the brake pedal while driving. This can cause dangerous overheating of the brakes and needless wear on the brake pads and linings.

▼ When the brakes get wet

When driving in rain or after washing the vehicle, the brakes may get wet. As a result, brake stopping distance will be longer. To dry the brakes, drive the vehicle at a safe speed while lightly depressing the brake pedal to heat up the brakes.

▼ Use of engine braking

Remember to make use of engine braking in addition to foot braking. When descending a grade, if only the foot brake is used, the brakes may start working improperly because of brake fluid overheating, caused by overheated brake pads. To help prevent this, shift into a lower gear to get stronger engine braking.

▼ Braking when a tire is punctured

Do not depress the brake pedal suddenly when a tire is punctured. This could cause

a loss of control of the vehicle. Keep driving straight ahead while gradually reducing speed. Then slowly pull off the road to a safe place.

■ Brake system

▼ Two separate circuits

Your vehicle has a dual circuit brake system. Each circuit works diagonally across the vehicle. If one circuit of the brake system should fail, the other half of the system still works. If one circuit fails, the brake pedal will go down much closer to the floor than usual and you will need to press it down much harder. And a much longer distance will be needed to stop the vehicle.

▼ Brake booster

The brake booster uses engine manifold vacuum to assist braking force. Do not turn off the engine while driving because that will turn off the brake booster, resulting in poor braking power.

The brakes will continue to work even when the brake booster completely stops functioning. If this happens, however, you will have to depress the pedal much harder than normal and the braking distance will increase.

▼ Brake assist system

▲ WARNING

Do not be overconfident about the brake assist. It is not a system that brings more braking ability to the vehicle beyond its braking capability. Always use the utmost care when driving regarding vehicle speed and safe distance.

▲ CAUTION

When you need to brake suddenly, continue depressing the brake pedal strongly to bring the effect of the brake assist.

Brake assist is a driver assistance system. It assists the brake power when the driver cannot depress the brake pedal strongly and the brake power is insufficient.

Brake assist generates the brake power according to the speed at which the driver depresses the brake pedal.

NOTE

When you depress the brake pedal strongly or suddenly, the following phenomena occur. However, even though these occur, they do not indi-

cate any malfunctions, and the brake assist system is operating properly.

- You might feel that the brake pedal is applied by lighter force and generates a greater braking force.
- You might hear the sound of ABS operating from the engine compartment.

■ Disc brake pad wear warning indicators

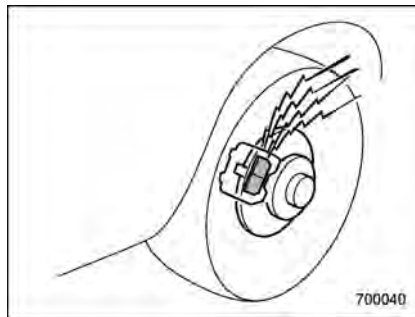

The disc brake pad wear warning indicators on the disc brakes give a warning noise when the brake pads are worn.

If a squeaking or scraping noise is heard from the disc brakes while braking, immediately have your vehicle inspected by the nearest SUBARU dealer.

ABS (Anti-lock Brake System)

WARNING

Always use the utmost care in driving – overconfidence because you are driving with an ABS equipped vehicle could easily lead to a serious accident.

CAUTION

- The ABS system does not always decrease stopping distance. You should always maintain a safe following distance from other vehicles.
- When driving on badly surfaced roads, gravel roads, icy road, or over deep newly fallen snow, stopping distances may be longer for a vehicle with the ABS system than one without. When driving under these conditions, therefore, reduce your speed and leave ample distance from other vehicles.
- When you feel the ABS system operating, you should maintain

constant brake pedal pressure. Do not pump the brake pedal since doing so may defeat the operation of the ABS system.

The ABS system prevents the lock-up of wheels which may occur during sudden braking or braking on slippery road surfaces. This helps prevent the loss of steering control and directional stability caused by wheel lock-up.

When the ABS system is operating, you may hear a chattering noise or feel a slight vibration in the brake pedal. This is normal when the ABS operates.

The ABS system will not operate when the vehicle speed is below approximately 6 mph (10 km/h).

■ ABS system self-check

You may feel a slight shock in the brake pedal and hear the operating sound of ABS from the engine compartment just after the vehicle is started. This is caused by an automatic functional test of the ABS system being carried out and does not indicate any abnormal condition.

■ ABS warning light

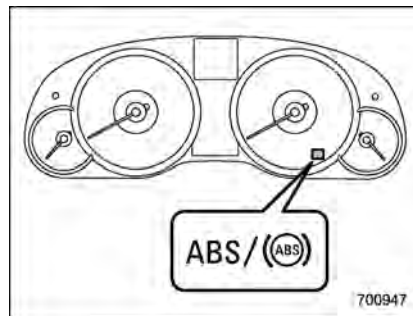

The ABS warning light illuminates when the ignition switch is turned to the “ON” position and turns off after approximately 2 seconds.

This is an indication that the ABS system is working properly.

CAUTION

If the warning light behaves as follows, the ABS system may not be working properly.

When the warning light is on, the ABS function shuts down; however, the conventional brake system continues to operate normally.

- The warning light does not illu-

minate when the ignition switch is turned to the "ON" position.

- The warning light illuminates when the ignition switch is turned to the "ON" position, but it does not turn off even when the vehicle speed exceeds approximately 8 mph (12 km/h).
- The warning light illuminates during driving.

If these occur, have the ABS system repaired at the first available opportunity by your SUBARU dealer.

NOTE

If the warning light behavior is as described in the following, the ABS system may be considered normal.

- The warning light illuminates right after the engine is started but turns off immediately, remaining off.
- The warning light remains illuminated after the engine has been started, but it turns off when the vehicle speed reaches approximately 8 mph (12 km/h).
- The warning light illuminates during driving, but it turns off immediately and remains off.

When driving with an insufficient battery

voltage such as when the engine is jump started, the ABS warning light may illuminate. This is due to the low battery voltage and does not indicate a malfunction. When the battery becomes fully charged, the light will turn off.

Electronic Brake Force Distribution (EBD) system

The EBD system maximizes the effectiveness of the brakes by allowing the rear brakes to supply a greater proportion of the braking force. It functions by adjusting the distribution of braking force to the rear wheels in accordance with the vehicle's loading condition and speed.

The EBD system is an integral part of the ABS system and uses some of the ABS system's components to perform its function of optimizing the distribution of braking force. If any of the ABS components used by the EBD function fails, the EBD system also stops working.

When the EBD system is operating, you may hear a chattering noise or feel a slight vibration in the brake pedal. This is normal and does not indicate a malfunction.

■ Steps to take if EBD system malfunctions

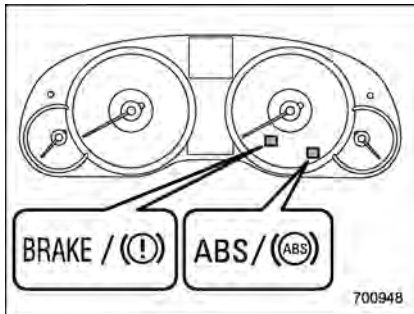

If a malfunction occurs in the EBD system, the system stops working and the brake system warning light and ABS warning light illuminate simultaneously.

The EBD system may be malfunctioning if the brake system warning light and ABS warning light illuminate simultaneously during driving.

Even if the EBD system fails, the conventional braking system will still function. However, the rear wheels will be more prone to locking when the brakes are applied harder than usual and the vehicle's motion may therefore become somewhat harder to control.

If the brake system warning light and ABS

warning light illuminate simultaneously, take the following steps.

1. Stop the vehicle in the nearest safe, flat place.
2. Shut down the engine, then restart it.
3. Release the parking brake. If both warning lights turn off, the EBD system may be malfunctioning.

Drive carefully to the nearest SUBARU dealer and have the system inspected.

4. If both warning lights illuminate again and remain illuminated after the engine has been restarted, shut down the engine again, apply the parking brake, and check the brake fluid level.
5. If the brake fluid level is not below the "MIN" mark, the EBD system may be faulty. Drive carefully to the nearest SUBARU dealer and have the system inspected.
6. If the brake fluid level is below the "MIN" mark, DO NOT drive the vehicle. Instead, have the vehicle towed to the nearest SUBARU dealer for repair.



WARNING

- **Driving with the brake system warning light on is dangerous. This indicates your brake system may not be working properly. If**

the light remains on, have the brakes inspected by a SUBARU dealer immediately.

- **If at all in doubt about whether the brakes are operating properly, do not drive the vehicle. Have your vehicle towed to the nearest SUBARU dealer for repair.**

Vehicle Dynamics Control system



WARNING

Always use the utmost care in driving – overconfidence because you are driving with a Vehicle Dynamics Control system equipped vehicle could easily lead to a serious accident.



CAUTION

- Even if your vehicle is equipped with Vehicle Dynamics Control system, winter tires should be used when driving on snow-covered or icy roads; in addition, vehicle speed should be reduced considerably. Simply having a Vehicle Dynamics Control system does not guarantee that the vehicle will be able to avoid accidents in any situation.
- Activation of the Vehicle Dynamics Control system is an indication that the road being travelled on has a slippery surface; since having Vehicle Dynamics Control is no guarantee

that full vehicle control will be maintained at all times and under all conditions, its activation should be seen as a sign that the speed of the vehicle should be reduced considerably.

- Whenever suspension components, steering components, or an axle are removed from a vehicle equipped with Vehicle Dynamics Control, have an authorized SUBARU dealer perform an inspection of that system.
- The following precautions should be observed in order to ensure that the Vehicle Dynamics Control system is operating properly.
 - All four wheels should be fitted with tires of the same size, type, and brand. Furthermore, the amount of wear should be the same for all four tires.
 - Keep the tire pressure at the proper level as shown on the vehicle placard attached to the driver's side door pillar.
 - Use only the specified temporary spare tire to replace a flat tire. With a temporary

spare tire, the effectiveness of the Vehicle Dynamics Control system is reduced and this should be taken into account when driving the vehicle in such a condition.

In the event of wheelspin and/or skidding on a slippery road surface and/or during cornering and/or an evasive maneuver, the Vehicle Dynamics Control system adjusts the engine's output and the wheels' respective braking forces to help maintain traction and directional control.

● Traction Control Function

The traction control function is designed to prevent spinning of the driving wheels on slippery road surfaces, thereby helping to maintain traction and directional control. Activation of this function is indicated by flashing of the Vehicle Dynamics Control operation indicator light.

● Skid Suppression Function

The skid suppression function is designed to help maintain directional stability by suppressing the wheels' tendency to slide sideways during steering operations. Activation of this function is indicated by flashing of the Vehicle Dynamics Control operation indicator light.

NOTE

- Slight twitching of the brake pedal may be felt when the Vehicle Dynamics Control system operates; a small degree of vehicle or steering wheel shaking may also be noticed in this situation. These are normal characteristics of Vehicle Dynamics Control operation and are no cause for alarm.
- When driving off immediately after starting the engine, a short-lived operation noise may be noticed coming from the engine compartment. This noise is generated as a result of a check being performed on the Vehicle Dynamics Control system and is normal.
- Depending on the timing of activation of the brakes, the brake pedal may seem to jolt when you drive off after starting the engine. This is a consequence of the Vehicle Dynamics Control operational check and is normal.
- In the circumstances shown in the following list, the vehicle may be more unstable than it feels to the driver. The Vehicle Dynamics Control System may therefore operate. Such operation does not indicate a system fault.
 - on gravel-covered or rutted roads
 - on unfinished roads
 - when the vehicle is towing a

trailer

- when the vehicle is fitted with snow tires or winter tires
- Activation of the Vehicle Dynamics Control system will cause operation of the steering wheel to feel slightly different compared to that for normal conditions.
- Even if the vehicle is equipped with a Vehicle Dynamics Control system, it is important that winter tires be used when driving on snow-covered or icy roads. (All four wheels should be fitted with tires of the same size and brand.)
- It is always important to reduce speed when approaching a corner, even if the vehicle is equipped with Vehicle Dynamics Control.
- All four wheels should be fitted with tires of the same size, type, and brand; furthermore, the amount of wear should be the same for all four tires. If these precautions are not observed and non-matching tires are used, it is quite possible that the Vehicle Dynamics Control system will be unable to operate correctly as intended.
- Always turn off the engine before replacing a tire as failure to do so may render the Vehicle Dynamics Control system unable to operate correctly.

■ Vehicle Dynamics Control system monitor

- ▼ Vehicle Dynamics Control warning light/Vehicle Dynamics Control operation indicator light

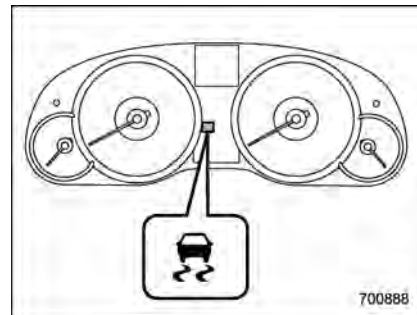

The light illuminates when the ignition switch is turned to the “ON” position and turns off several seconds after the engine has started. This lighting pattern indicates that the Vehicle Dynamics Control system is operating normally.

- ▽ Vehicle Dynamics Control warning light

**CAUTION**

Because the Vehicle Dynamics Control system controls each brake

– CONTINUED –

through the ABS, whenever the ABS stops operating due to a malfunction in that electrical system, the Vehicle Dynamics Control will also become unable to control all four brakes. Thus Vehicle Dynamics Control system operation halts and the warning light illuminates. Although both the Vehicle Dynamics Control system and the ABS will be inoperable in this situation, it will still be possible to stop the vehicle using normal braking. The Vehicle Dynamics Control system and the ABS do not adversely affect operation of the vehicle in any way when they are inoperable. However should such a situation occur, drive with care and have an authorized SUBARU dealer carry out an inspection of those systems at the first available opportunity.

NOTE

- When a malfunction has occurred in the Vehicle Dynamics Control electrical system, only the warning light will illuminate. In such an event, the ABS will still be operating normally.
- The warning light will also illuminate when a problem occurs with the ABS or Vehicle Dynamics Control electronic

control systems.

The warning light illuminates when the ignition switch is turned to the "ON" position and turns off several seconds after the engine has started. This lighting pattern indicates that the Vehicle Dynamics Control system is operating normally.

The following situations could indicate a malfunction of the Vehicle Dynamics Control system. If any of these situations occur, have an authorized SUBARU dealer carry out an inspection of the system at the first available opportunity.

- The warning light does not illuminate when the ignition switch is turned to the ON position.
- The warning light illuminates while the vehicle is being driven.

NOTE

When the warning light turns on and off in the following way, it indicates that the Vehicle Dynamics Control system is operating normally.

- Although illuminating after the engine has been started, the warning light quickly turns off and remains off.
- The warning light illuminates when the vehicle is being driven, it then turns off and remains off.

▽ Vehicle Dynamics Control operation indicator light

The indicator light flashes during activation of the skid suppression function and during activation of the traction control function.

NOTE

- **The indicator light may remain illuminated for a while after the engine has been started, especially in cold weather. This occurs because the engine has not yet warmed up and is completely normal. The light will turn off when the engine has reached a suitable operating temperature.**
- **When an engine problem occurs and the CHECK ENGINE warning light/malfunction indicator lamp illuminates, the indicator light will also illuminate.**

The following two situations could indicate malfunction of the Vehicle Dynamics Control system. If either of these situations occurs, have an authorized SUBARU dealer carry out an inspection of that system at the first available opportunity.

- The indicator light does not illuminate when the ignition switch is turned to the ON position.
- The indicator light fails to turn off after the engine is started, even when several

minutes have passed to allow the engine to heat up sufficiently.

▼ **Vehicle Dynamics Control OFF indicator light**

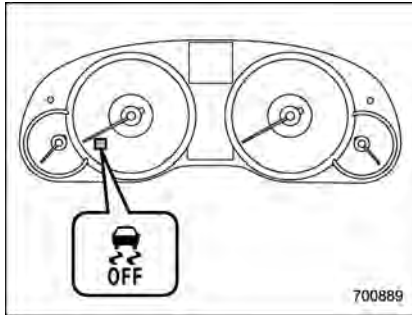

The light illuminates when the ignition switch is turned to the “ON” position and turns off after approximately 2 seconds. The light illuminates when the Vehicle Dynamics Control OFF switch is pressed to deactivate the Vehicle Dynamics Control system.

The following two situations could indicate a malfunction of the Vehicle Dynamics Control system. If either should occur, have an authorized SUBARU dealer carry out an inspection of that system at the first available opportunity.

- The indicator light does not illuminate

when the ignition switch is turned to the ON position.

- The indicator light does not turn off approximately 2 seconds after the ignition switch has been turned to the ON position.

■ **Vehicle Dynamics Control OFF switch**

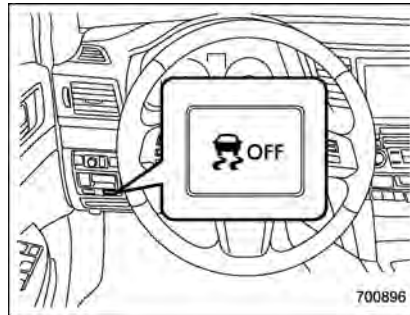

Pressing the switch to deactivate the Vehicle Dynamics Control system can facilitate the following operations.

- a standing start on a steeply sloping road with a snowy, gravel-covered, or otherwise slippery surface
- extrication of the vehicle when its wheels are stuck in mud or deep snow

When the switch is pressed during engine operation, the Vehicle Dynamics Control

OFF indicator light on the combination meter illuminates. The Vehicle Dynamics Control system will be deactivated. When the switch is pressed again to reactivate the Vehicle Dynamics Control system, the Vehicle Dynamics Control OFF indicator light turns off.

You should not deactivate the Vehicle Dynamics Control system except under the above-mentioned situations.

CAUTION

The Vehicle Dynamics Control system helps prevent unstable vehicle motion such as skidding using control of the brakes and engine power. Do not turn off the Vehicle Dynamics Control system unless it is absolutely necessary. If you must turn off the Vehicle Dynamics Control system, drive very carefully based on the road surface condition.

NOTE

- When the switch has been pressed to deactivate the Vehicle Dynamics Control system, the Vehicle Dynamics Control system automatically reactivates itself the next time the ignition switch is turned to the “LOCK” position and the engine is restarted.

- If the switch is held down for 10 seconds or longer, the indicator light turns off, the Vehicle Dynamics Control system is activated, and the system ignores any further pressing of the switch. To make the switch usable again, turn the ignition switch to the “LOCK” position and restart the engine.
- When the switch is pressed to deactivate the Vehicle Dynamics Control system, the vehicle’s running performance is comparable with that of a vehicle that does not have a Vehicle Dynamics Control system. Do not deactivate the Vehicle Dynamics Control system except when absolutely necessary.
- Even when the Vehicle Dynamics Control system is deactivated, components of the brake control system may still activate. When the brake control system is activated, the Vehicle Dynamics Control operation indicator light illuminates.

Tire pressure monitoring system (TPMS) (if equipped)

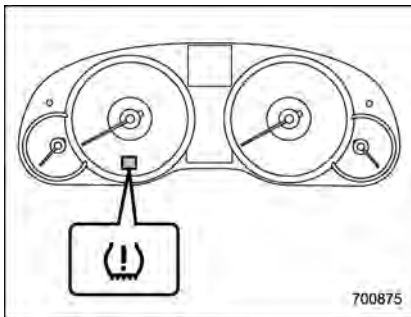

The tire pressure monitoring system provides the driver with a warning message by sending a signal from a sensor that is installed in each wheel when tire pressure is severely low.

The tire pressure monitoring system will activate only when the vehicle is driven at speeds above 20 mph (32 km/h). Also, this system may not react immediately to a sudden drop in tire pressure (for example, a blow-out caused by running over a sharp object).

WARNING

If the low tire pressure warning light illuminates while driving, never brake suddenly and keep driving straight ahead while gradually reducing speed. Then slowly pull off the road to a safe place. Otherwise an accident involving serious vehicle damage and serious personal injury could occur.

Check the pressure for all four tires and adjust the pressure to the COLD tire pressure shown on the tire placard on the door pillar on the driver’s side.

Even when the vehicle is driven a very short distance, the tires get warm and their pressures increase accordingly. Be sure to let the tires cool thoroughly before adjusting their pressures to the standard values shown on the tire placard. Refer to “Tires and wheels” [11-35](#). The tire pressure monitoring system does not function when the vehicle is stationary. After adjusting the tire pressures, increase the vehicle speed to at least 20 mph (32 km/h) to start the TPMS re-checking of the tire inflation pressures. If the tire pressures are now above the severe

low pressure threshold, the low tire pressure warning light should turn off a few minutes later.

If this light still illuminates while driving after adjusting the tire pressure, a tire may have significant damage and a fast leak that causes the tire to lose air rapidly. If you have a flat tire, replace it with a spare tire as soon as possible.

When a spare tire is mounted or a wheel rim is replaced without the original pressure sensor/transmitter being transferred, the low tire pressure warning light will illuminate steadily after blinking for approximately one minute. This indicates the TPMS is unable to monitor all four road wheels. Contact your SUBARU dealer as soon as possible for tire and sensor replacement and/or system resetting.

Do not inject any tire liquid or aerosol tire sealant into the tires, as this may cause a malfunction of the tire pressure sensors. If the light illuminates steadily after blinking for approximately one minute, promptly contact a SUBARU dealer to have the system inspected.



CAUTION

Do not place metal film or any metal parts under the driver's seat. This may cause poor reception of the signals from the tire pressure sensors, and the tire pressure monitoring system will not function properly.

NOTE

This device complies with Part 15 of the FCC Rules and with RSS-210 of Industry Canada. Operation is subject to the following two conditions: (1) This device may not cause harmful interference, and (2) this device must accept any interference received, including interference that may cause undesired operation.

Changes or modifications not expressly approved by the party responsible for compliance could void the user's authority to operate the equipment.



WARNING

Parking your vehicle

- Never leave unattended children or pets in the vehicle. They could accidentally injure themselves or others through inadvertent operation of the vehicle. Also, on hot or sunny days, the temperature in a closed vehicle could quickly become high enough to cause severe or possibly fatal injuries to them.
- Do not park the vehicle over flammable materials such as dry grass, waste paper or rags, as they may burn easily if they come near hot engine or exhaust system parts.
- Be sure to stop the engine if you take a nap in the vehicle. If engine exhaust gas enters the passenger compartment, occupants in the vehicle could die from carbon monoxide (CO) contained in the exhaust gas.

■ Electronic parking brake

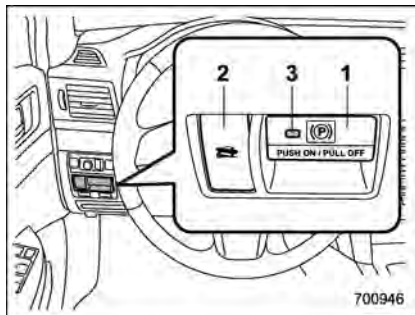

- 1) Parking brake switch
- 2) Hill Holder switch
- 3) Indicator light

▲ WARNING

- Before exiting the vehicle, make sure that you turn off the engine. Otherwise, the parking brake may be released and an accident may occur.
- If the brake system warning light flashes, the electronic parking brake system may be malfunctioning. Immediately stop your vehicle in a safe location, use tire stops under the tires to prevent the vehicle from moving

and contact your SUBARU dealer.

▲ CAUTION

- When the electronic parking brake system has a malfunction and the parking brake cannot be applied, contact your SUBARU dealer immediately for an inspection. If you have to park your vehicle in such conditions, perform the following procedure.
 - Stop your vehicle in a flat location.
 - Shift the shift lever in the “1” or reverse position (MT models).
 - Shift the select lever in the “P” position (AT or CVT models). When the select lever cannot be shifted into the “P” position, you must release shift lock. Refer to “Shift lock function” 7-20.
 - Use tire stops under the tires to prevent the vehicle from moving.
- Never drive while the parking brake is applied because this will

cause unnecessary wear on the brake linings. Before starting to drive, always make sure that the parking brake has been released and the brake system warning light has turned off.

Your vehicle is equipped with an electronic parking brake. You can apply/release the parking brake by operating the parking brake switch.

To apply: Depress the brake pedal and press the parking brake switch firmly.

To release: Pull the parking brake switch toward you while the ignition switch is in the “ON” position and the brake pedal (all models) and the clutch pedal (MT models) are depressed.

When the parking brake is applied while the ignition switch is in the “ON” position, the brake system warning light and the indicator light on the parking brake switch illuminate. Refer to “Brake system warning light” 3-17.

NOTE

- If the parking brake switch is pulled with the ignition switch in the “Acc” or “LOCK” position, the parking brake is not released.
- If the parking brake switch is pulled

without depressing the brake pedal or the clutch pedal, the parking brake is not released.

- When the parking brake is being applied or released, noise may be noticed. However, this is not a malfunction.
- When the electronic parking brake system has a malfunction or the electronic parking brake operation is prohibited temporarily, if the parking brake switch is operated, a chirp sound is heard and the brake system warning light flashes.
- When you cannot release the parking brake due to, for example, a system malfunction, you can release it by using the parking brake release tool. Refer to “Electronic parking brake – if the electronic parking brake cannot be released” 9-16.

▼ Automatic release function by gas pedal

The electronic parking brake system has an automatic release function. The parking brake will be automatically released by depressing the accelerator pedal. However, the automatic release function does not operate under the following conditions.

- Any door (other than the trunk lid or rear gate) is open.

- The driver’s seatbelt is not fastened.

If the parking brake is automatically released, the brake system warning light and the indicator on the parking brake switch turn off.

NOTE

Even if you have applied the parking brake by pressing the parking brake switch, the parking brake will be automatically released when the accelerator pedal is depressed.

▼ Hill Holder function

The electronic parking brake system has a Hill Holder function. If the Hill Holder function is activated, the parking brake will be automatically applied when stopping on an uphill slope with the brake pedal depressed. In this case, the brake system warning light and the indicator light on the parking brake switch illuminate.

NOTE

- The Hill Holder function may not activate on a gentle uphill slope. In this case, manually apply the electronic parking brake.
- If you do not depress the brake pedal sufficiently, the Hill Holder function may not operate properly. However, this is not a malfunction. When

stopping on an uphill slope, depress the brake pedal firmly and release it after the brake system warning light illuminates.

- Depending on the condition of the road surface and braking force, the brakes operate temporarily and feel different than usual.
- When the electronic parking brake system has a malfunction while the Hill Holder function is activated, a chirp sound is heard, the Hill Holder indicator light turns off and the brake system warning light flashes.
- The Hill Holder function does not reactivate when parking with the electronic parking brake released after the Hill Holder function is activated. If necessary, manually apply the electronic parking brake.
- If the seatbelt is not fastened when the Hill Holder function is activated, the vehicle may not start moving smoothly from a stop, or a noise may be heard from the brake components.

▽ Hill Holder switch



WARNING

When stopping on an uphill slope with the Hill Holder function activated, release the brake pedal after

the brake system warning light has illuminated. Otherwise, the Hill Holder function may not operate properly and an accident may occur.

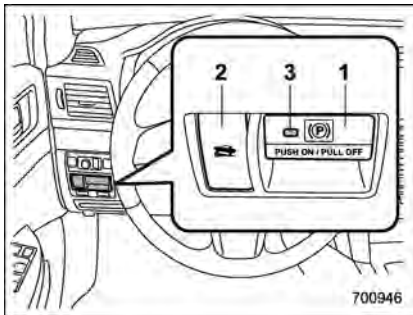

- 1) Parking brake switch
- 2) Hill Holder switch
- 3) Indicator light

You can activate/deactivate the Hill Holder function by pressing the Hill Holder switch.

To activate: Press the Hill Holder switch.

To deactivate: Press the Hill Holder switch again.

Deactivate the Hill Holder function under the following conditions.

- When towing a trailer
- When carrying a heavy load

- When you do not frequently use the parking brake when stopping on an uphill slope

NOTE

- If the Hill Holder switch is pressed for more than 30 seconds, the Hill Holder indicator light turns off, the brake system warning light flashes and the system ignores any further pressing of the switch. To activate the switch again, turn the ignition switch to the “LOCK” position and restart the engine.

- When the Hill Holder function is deactivated while the Hill Holder function has a malfunction, if you press the Hill Holder switch, a chirp sounds.

▽ Hill Holder indicator light

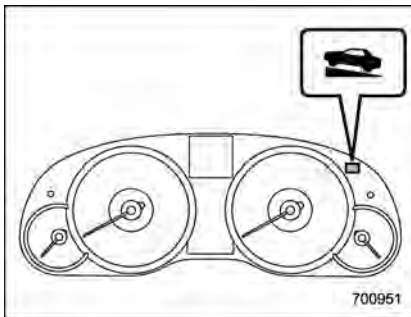

When the Hill Holder function is activated, the Hill Holder indicator light illuminates. Refer to “Hill Holder indicator light” 3-19.

▼ Emergency brake



Use the emergency brake only in case of an emergency. If the emergency brake is excessively used, the brake parts will wear down faster or the brake may not work sufficiently due to rear wheel brake overheating.

NOTE

While using the emergency brake, the brake system warning light and the indicator light on the parking brake switch illuminate and a chirp sounds.

If the foot brake has a malfunction, you can stop the vehicle by pressing the parking brake switch continuously.

While applying the emergency brake, the brake system warning light and the indicator on the parking brake switch illuminate and a chirp sounds.

▼ Electronic parking brake system warning

CAUTION

If the brake system warning light flashes, the electronic parking brake system may be malfunctioning. Immediately stop your vehicle in the nearest safe location and contact your SUBARU dealer.

If a malfunction occurs in the electronic parking brake system, the brake system warning light flashes. Refer to "Electronic parking brake system warning" 3-19.

■ Parking tips

When parking your vehicle, always perform the following items.

- Apply the parking brake firmly.
- For MT models, put the shift lever in the "1" (1st) for upgrade or "R" (Reverse) for a downgrade.
- For AT and CVT models, put the select lever in the "P" (Park) position.

Never rely on the transmission alone to hold the vehicle.

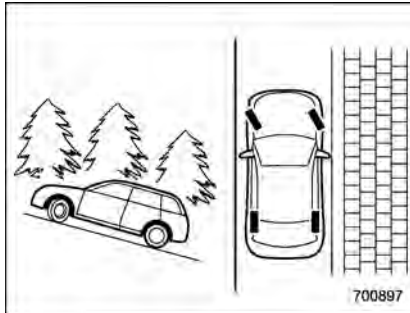

When parking on a hill, always turn the steering wheel as described here. When the vehicle is headed up the hill, the front wheels should be turned away from the curb.

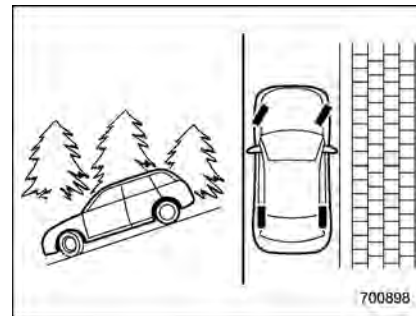

When facing downhill, the front wheels should be turned into the curb.

Cruise control

Cruise control enables you to maintain a constant vehicle speed without holding your foot on the accelerator pedal and it is operative when the vehicle speed is 25 mph (40 km/h) or more.



WARNING

Do not use the cruise control under any of the following conditions. These may cause loss of vehicle control.

- driving up or down a steep grade
- driving on slippery or winding roads
- driving in heavy traffic
- When towing a trailer

NOTE

- If you press the “CRUISE” main switch button while turning the ignition switch “ON”, the cruise control function is deactivated and the cruise control indicator light flashes. To reactivate the cruise control function, turn the ignition switch back to the “Acc” or “LOCK” position, and then turn it again to the “ON” position.
- Make sure the “CRUISE” main

switch is turned off when the cruise control is not in use to avoid unintentionally setting of the cruise control.

■ To set cruise control

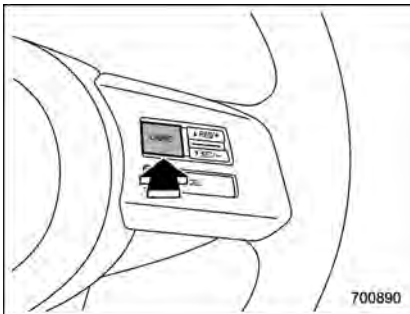

1. Press the “CRUISE” main switch button.

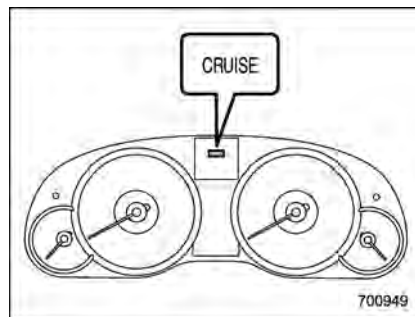

The cruise control indicator light on the combination meter will illuminate.

2. Depress the accelerator pedal until the vehicle reaches the desired speed.

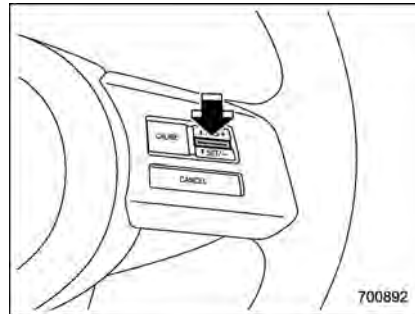

3. Press the “RES/SET” switch to the “SET” side and release it. Then release

the accelerator pedal.

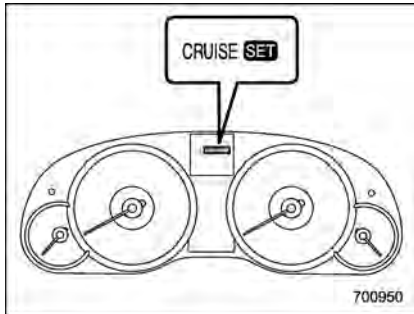

At this time, the cruise control set indicator light is illuminated in the combination meter.

The vehicle will maintain the desired speed.

Vehicle speed can be temporarily increased while driving with the cruise control activated. Simply depress the accelerator pedal to accelerate the vehicle. When the accelerator pedal is released, the vehicle will return to and maintain the previous cruising speed.

■ To temporarily cancel the cruise control

The cruise control can be temporarily canceled in the following ways.

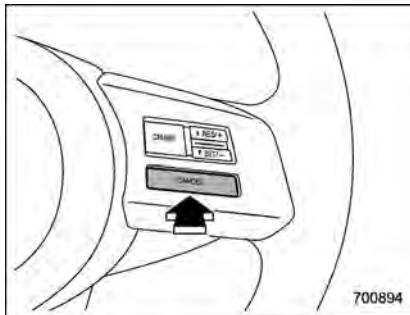

- Press the "CANCEL" button.
- Depress the brake pedal.
- Depress the clutch pedal (MT models only).
- Shift the select lever into the "N" position (AT and CVT models).
- Shift the shift lever into the neutral position (MT models only).

The cruise control set indicator light in the combination meter turns off when the cruise control is canceled.

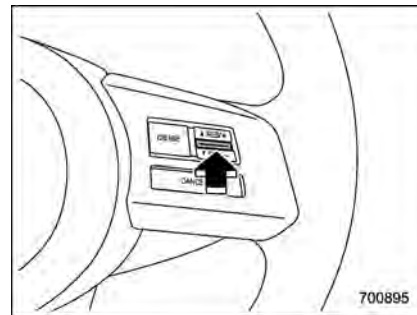

To resume the cruise control after it has been temporarily canceled and with vehicle speed of approximately 20 mph (32 km/h) or more, press the "RES/SET" switch to the "RES" side to return to the original cruising speed automatically.

The cruise control set indicator light in the combination meter will automatically illuminate at this time.

■ To turn off the cruise control

There are two ways to turn off the cruise control:

- Press the "CRUISE" main switch button again.
- Turn the ignition switch to the "Acc" or "LOCK" position (but only when the vehicle is completely stopped).

■ To change the cruising speed

- ▼ To increase the speed (by the “RES/SET” switch)

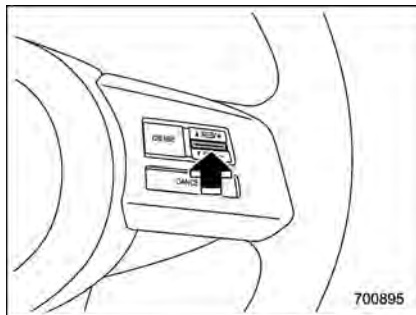

Press the “RES/SET” switch to the “RES” side and hold it until the vehicle reaches the desired speed. Then, release the switch. The vehicle speed at that moment will be memorized and treated as the new set speed.

When the difference between the actual vehicle speed and the set speed is less than 4 mph (6.8 km/h), the set speed can be increased 1 mph (1.6 km/h) each time by pressing the “RES/SET” switch to the “RES” side quickly.

- ▼ To increase the speed (by accelerator pedal)

1. Depress the accelerator pedal to accelerate the vehicle to the desired speed.
2. Press the “RES/SET” switch to the “SET” side once. Now the desired speed is set and the vehicle will keep running at that speed without depressing the accelerator pedal.

NOTE

If the difference between the actual vehicle speed when the button is pressed and the speed last time you set is less than 4 mph (6.8 km/h), the vehicle speed will be lowered by 1 mph (1.6 km/h). This occurs because the cruise control system unit regards this operation as that intended to decrease the vehicle speed.

- ▼ To decrease the speed (by the “RES/SET” switch)

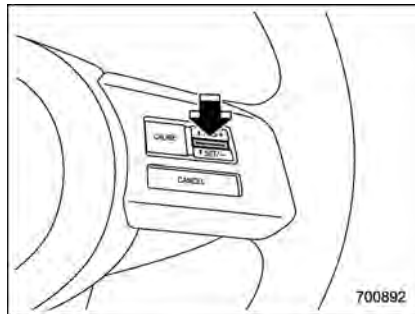

Press the “RES/SET” switch to the “SET” side and hold it until the vehicle reaches the desired speed. Then, release the switch. The vehicle speed at that moment will be memorized and treated as the new set speed.

When the difference between the actual vehicle speed and the set speed is less than 4 mph (6.8 km/h), the set speed can be lowered 1 mph (1.6 km/h) each time by pressing the “RES/SET” switch to the “SET” side quickly.

▼ **To decrease the speed (by brake pedal)**

1. Depress the brake pedal to release cruise control temporarily.
2. When the speed decreases to the desired speed, press the "RES/SET" switch to the "SET" side once. Now the desired speed is set and the vehicle will keep running at that speed without depressing the accelerator pedal.

■ **Cruise control indicator light**

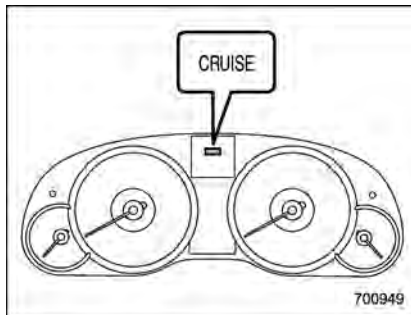

The cruise control indicator light illuminates when the ignition switch is turned to the "ON" position and turns off after approximately 3 seconds.

The light illuminates when the "CRUISE" main switch is pressed.

NOTE

- If you press the "CRUISE" main switch button while turning the ignition switch "ON", the cruise control function is deactivated and the cruise control indicator light flashes. To reactivate the cruise control function, turn the ignition switch back to the "Acc" or "LOCK" position, and then turn it again to the "ON" position.
- If this indicator light and the CHECK

ENGINE warning light/malfunction indicator lamp flash simultaneously during driving, have the vehicle checked by your nearest SUBARU dealer.

■ **Cruise control set indicator light**

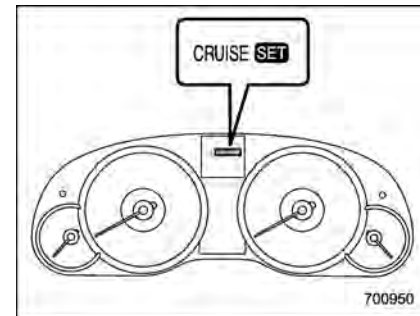

The cruise control set indicator light illuminates when the ignition switch is turned to the "ON" position and turns off after approximately 3 seconds.

The light illuminates when vehicle speed has been set.

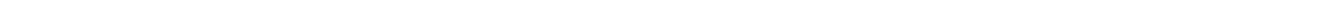
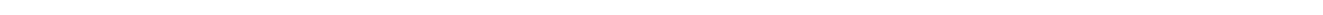
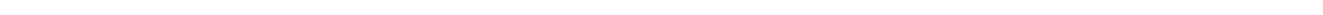
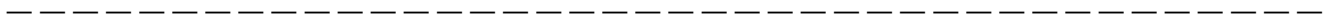

| | | | |
|--|------|---|------|
| New vehicle break-in driving – the first 1,000 miles (1,600 km) | 8-2 | Rocking the vehicle | 8-11 |
| Fuel economy hints | 8-2 | Loading your vehicle | 8-12 |
| Engine exhaust gas (carbon monoxide) | 8-2 | Vehicle capacity weight | 8-13 |
| Catalytic converter | 8-3 | GVWR and GAWR (Gross Vehicle Weight Rating and Gross Axle Weight Rating) | 8-13 |
| Periodic inspections | 8-4 | Roof rails with integrated crossbars (Outback) | 8-14 |
| Driving in foreign countries | 8-4 | Trailer hitch (Outback — if equipped) | 8-16 |
| Driving tips for AWD vehicles | 8-5 | Connecting a trailer | 8-17 |
| Off road driving | 8-6 | When you do not tow a trailer | 8-18 |
| Legacy | 8-6 | Trailer towing | 8-19 |
| Outback | 8-6 | Warranties and maintenance | 8-19 |
| Winter driving | 8-8 | Maximum load limits | 8-19 |
| Operation during cold weather | 8-8 | Trailer hitches | 8-22 |
| Driving on snowy and icy roads | 8-9 | Connecting a trailer | 8-23 |
| Corrosion protection | 8-10 | Trailer towing tips | 8-24 |
| Snow tires | 8-10 | | |
| Tire chains | 8-11 | | |

New vehicle break-in driving – the first 1,000 miles (1,600 km)

The performance and long life of your vehicle are dependent on how you handle and care for your vehicle while it is new. Follow these instructions during the first 1,000 miles (1,600 km):

- Do not race the engine. And do not allow engine speed to exceed 4,000 rpm except in an emergency.
- Do not drive at one constant engine or vehicle speed for a long time, either fast or slow.
- Avoid starting suddenly and rapid acceleration, except in an emergency.
- Avoid hard braking, except in an emergency.

The same break-in procedures should be applied to a newly installed or overhauled engine or when brake pads or brake linings are replaced with new ones.

Fuel economy hints

The following suggestions will help to save your fuel.

- Select the proper gear position for the speed and road conditions.
- Avoid sudden acceleration or deceleration. Always accelerate gently until you reach the desired speed. Then try to maintain that speed for as long as possible.
- Do not pump the accelerator and avoid racing the engine.
- Avoid unnecessary engine idling.
- Keep the engine properly tuned.
- Keep the tires inflated to the correct pressure shown on the tire placard, which is located under the door latch on the driver's side. Low pressure will increase tire wear and fuel consumption.
- Use the air conditioner only when necessary.
- Keep the front and rear wheels in proper alignment.
- Avoid carrying unnecessary luggage or cargo.
- The indication of the ECO gauge shows a reference for saving fuel. For details, refer to "ECO gauge" 3-8.

Engine exhaust gas (carbon monoxide)



WARNING

- **Never inhale engine exhaust gas. Engine exhaust gas contains carbon monoxide, a colorless and odorless gas which is dangerous, or even lethal, if inhaled.**
- **Always properly maintain the engine exhaust system to prevent engine exhaust gas from entering the vehicle.**
- **Never run the engine in a closed space, such as a garage, except for the brief time needed to drive the vehicle in or out of it.**
- **Avoid remaining in a parked vehicle for a lengthy time while the engine is running. If that is unavoidable, then use the ventilation fan to force fresh air into the vehicle.**
- **Always keep the front ventilator inlet grille free from snow, leaves or other obstructions to ensure that the ventilation system always works properly.**
- **If at any time you suspect that**

exhaust fumes are entering the vehicle, have the problem checked and corrected as soon as possible. If you must drive under these conditions, drive only with all windows fully open.

- Keep the trunk lid (Legacy) or rear gate (Outback) closed while driving to prevent exhaust gas from entering the vehicle.

NOTE

Due to the expansion and contraction of the metals used in the manufacture of the exhaust system, you may hear a crackling sound coming from the exhaust system for a short time after the engine has been shut off. This sound is normal.

Catalytic converter

WARNING

- Avoid fire hazards. Do not drive or park the vehicle anywhere near flammable materials (e.g. grass, paper, rags or leaves), because the catalytic converter operates at very high temperatures.
- Keep everyone and flammable materials away from the exhaust pipe while the engine is running. The exhaust gas is very hot.

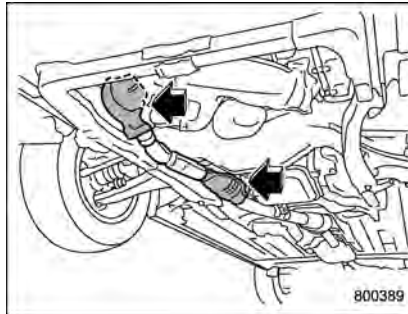

2.5 L non-turbo models

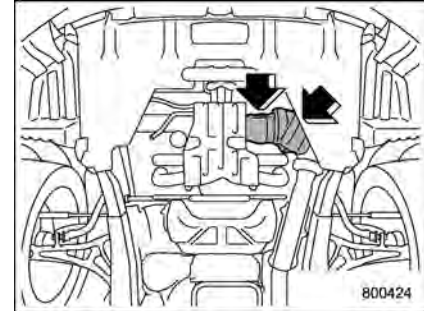

2.5 L turbo models

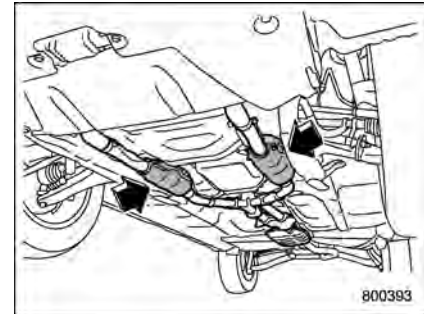

3.6 L models

The catalytic converter is installed in the exhaust system. It serves as catalyst to reduce HC, CO and NO_x in exhaust gases, thus providing cleaner exhaust.

To avoid damage to the catalytic converter:

- Use only unleaded gasoline. Even a small amount of leaded gasoline will damage the catalytic converter.
- Never start the engine by pushing or pulling the vehicle.
- Avoid racing the engine.
- Never turn off the ignition switch while the vehicle is moving.
- Keep your engine tuned-up. If you feel the engine running rough (misfiring, backfiring or incomplete combustion), have your vehicle checked and repaired by an authorized SUBARU dealer.
- Do not apply undercoating or rust prevention treatment to the heat shield of catalytic converter and the exhaust system.
- Do not drive with an extremely low fuel level.

Periodic inspections

To keep your vehicle in the best condition at all times, always have the recommended maintenance services listed in the maintenance schedule in the "Warranty and Maintenance Booklet" performed at the specified time or mileage intervals.

Driving in foreign countries

When planning to use your vehicle in another country:

- Confirm the availability of the correct fuel. Refer to "Fuel requirements" 7-2.
- Comply with all regulations and requirements of each country.

Driving tips for AWD vehicles

WARNING

- Always maintain a safe driving speed according to the road and weather conditions in order to avoid having an accident on a sharp turn, during sudden braking or under other similar conditions.
- Always use the utmost care in driving – overconfidence because you are driving an All-Wheel Drive vehicle could easily lead to a serious accident.

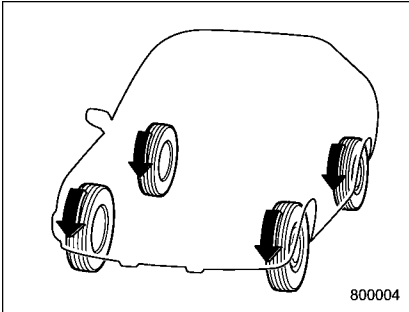

All-Wheel Drive distributes the engine

power to all four wheels. AWD vehicles provide better traction when driving on slippery, wet or snow-covered roads and when moving out of mud, dirt and sand. By shifting power between the front and rear wheels, SUBARU AWD can also provide added traction during acceleration, and added engine braking force during deceleration.

Therefore, your SUBARU AWD vehicle may handle differently than an ordinary two wheel drive vehicle and it contains some features unique to AWD. For safety purposes as well as to avoid damaging the AWD system, you should keep the following tips in mind:

- An AWD vehicle is better able to climb steeper roads under snowy or slippery conditions than a two wheel drive vehicle. There is little difference in handling, however, during extremely sharp turns or sudden braking. Therefore, when driving down a slope or turning corners, be sure to reduce your speed and maintain an ample distance from other vehicles.
- When replacing a tire, make sure you use only the same size, circumference, construction, brand, and load range as the original tires listed on the tire placard. Using other sizes, circumferences or construction may result in severe mechanical damage to the drive train of your

vehicle and may affect ride, handling, braking, speedometer/odometer calibration, and clearance between the body and tires. It also may be dangerous and lead to loss of vehicle control.

- If you use a temporary spare tire to replace a flat tire, be sure to use the original temporary spare tire stored in the vehicle. Using other sizes may result in severe mechanical damage to the drive train of your vehicle.
- Always check the cold tire pressure before starting to drive. The recommended tire pressure is provided on the tire placard, which is located on the door pillar on the driver's side.
- There are some precautions that you must observe when towing your vehicle. For detailed information, refer to "Towing" 9-12.

Off road driving



WARNING

- Always maintain a safe driving speed according to the road and weather conditions in order to avoid having an accident on a sharp turn, during sudden braking or under other similar conditions.
- Always use the utmost care in driving – overconfidence because you are driving an All-Wheel Drive vehicle could easily lead to a serious accident.

■ Legacy

Your AWD vehicle is neither a conventional off-road vehicle nor an all terrain vehicle. It is a passenger car designed primarily for on-road use. The AWD feature gives it some limited off-road capabilities in situations in which the driving surface is relatively level, obstruction-free and otherwise similar to on-road driving conditions. Operating it under other than those conditions could subject the vehicle to excessive stress which might result in damage not eligible for repair

under warranty. If you do take your SUBARU off road, you should review the common sense precautions in the next section (applicable to the Outback) for general guidance. But please keep in mind that your vehicle's off-road capabilities are more limited than those of the Outback.

Never attempt to drive through pools and puddles, or roads flooded with water. Water entering the engine air intake or the exhaust pipe or water splashing onto electrical parts may damage your vehicle and may cause it to stall.

■ Outback

Because of the AWD feature and higher ground clearance, your SUBARU can be driven on ordinary roads or off-road. But please keep in mind that an AWD SUBARU is a passenger car and is neither a conventional off-road vehicle nor an all-terrain vehicle. If you do take your SUBARU off-road, certain common sense precautions such as those in the following list should be taken:

- Make certain that you and all of your passengers are wearing seatbelts.
- Carry some emergency equipment, such as a towing rope or chain, a shovel, wheel blocks, first aid kit and cell phone or citizens band radio.

- Drive carefully. Do not take unnecessary risks by driving in dangerous areas or over rough terrain.
- Slow down and employ extra caution at all times. When driving off-road, you will not have the benefit of marked traffic lanes, banked curves, traffic signs and the like.
- Do not drive across steep slopes. Instead, drive either straight up or straight down the slopes. A vehicle can much more easily tip over sideways than it can end over end. Avoid driving straight up or down slopes that are too steep.
- Avoid sharp turning maneuvers, especially at higher speeds.
- Do not grip the inside or spokes of the steering wheel. A bad bump could jerk the wheel and injure your hands. Instead drive with your fingers and thumbs on the outside of the rim.
- If driving through water, such as when crossing shallow streams, first check the depth of the water and the bottom of the stream bed for firmness and ensure that the bed of the stream is flat. Drive slowly and completely through the stream. The water should be shallow enough that it does not reach the vehicle's undercarriage. Water entering the engine air intake or the exhaust pipe or water splashing onto electrical parts may damage your

vehicle and may cause it to stall. Never attempt to drive through rushing water; regardless of its depth, it can wash away the ground from under your tires, resulting in possible loss of traction and even vehicle rollover.

- Always check your brakes for effectiveness immediately after driving in sand, mud or water. Do this by driving slowly and stepping on the brake pedal. Repeat that process several times to dry out the brake discs and brake pads.
- Do not drive or park over or near flammable materials such as dry grass or fallen leaves, as they may burn easily. The exhaust system is very hot while the engine is running and right after the engine stops. This could create a fire hazard.
- After driving through tall grass, mud, rocks, sand, rivers, etc., check that there is no grass, bush, paper, rags, stones, sand, etc. adhering to or trapped on the underbody. Clear off any such matter from the underbody. If the vehicle is used with these materials trapped or adhering to the underbody, a mechanical breakdown or fire could occur.
- Secure all cargo carried inside the vehicle and make certain that it is not piled higher than the seatbacks. During sudden stops or jolts, unsecured cargo

could be thrown around in the vehicle and cause injury. Do not pile heavy loads on the roof. Those loads raise the vehicle's center of gravity and make it more prone to tip over.

- If you must rock the vehicle to free it from sand or mud, depress the accelerator pedal slightly and move the select lever back and forth between "D" and "R" repeatedly. Do not race the engine. For the best possible traction, avoid spinning the wheels when trying to free the vehicle.
- When the road surface is extremely slippery, you can obtain better traction by starting the vehicle with the transmission in 2nd than 1st (both for MT, AT and CVT). For AT and CVT models, refer to "Selection of manual mode" 7-21.
- Never equip your vehicle with tires larger than those specified in this manual.
- Wash the vehicle's underbody after off-road driving. Suspension components are particularly prone to dirt buildup, so they need to be washed thoroughly.
- Frequent driving of an AWD vehicle under hard-driving conditions such as rough roads or off roads will necessitate more frequent replacement of engine oil, brake fluid and transmission oil than that specified in the maintenance schedule described in the "Warranty and Maintenance Booklet".

Remember that damage done to your SUBARU while operating it off-road and not using common sense precautions such as those listed above is not eligible for warranty coverage.

Winter driving



■ Operation during cold weather

Carry some emergency equipment, such as a window scraper, a bag of sand, flares, a small shovel and jumper cables.

Check the battery and cables. Cold temperatures reduce battery capacity. The battery must be in good condition to provide enough power for cold winter starts.

Use an engine oil of proper grade and viscosity for cold weather. Heavy summer oil will cause harder starting.

Keep the door locks from freezing by squirting them with deicer or glycerin.

Forcing a frozen door open may damage or separate the rubber weather strips around the door. If the door is frozen, use hot water to melt the ice, and afterwards thoroughly wipe the water away.

Use a windshield washer fluid that contains an antifreeze solution. Do not use engine antifreeze or other substitutes because they may damage the paint of the vehicle.

SUBARU Windshield Washer Fluid contains 58.5% methyl alcohol and 41.5% surfactant, by volume. Its freezing temperature varies according to how much it is diluted, as indicated in the following table.

| Washer Fluid Concentration | Freezing Temperature |
|----------------------------|----------------------|
| 30% | 10.4°F (-12°C) |
| 50% | -4°F (-20°C) |
| 100% | -49°F (-45°C) |

In order to prevent freezing of washer fluid, check the freezing temperatures in the table above when adjusting the fluid concentration to the outside temperature.

If you fill the reservoir tank with a fluid with a different concentration from the one used previously, purge the old fluid from the piping between the reservoir tank and

washer nozzles by operating the washer for a certain period of time. Otherwise, if the concentration of the fluid remaining in the piping is too low for the outside temperature, it may freeze and block the nozzles.

▲ CAUTION

- **Adjust the washer fluid concentration appropriately for the outside temperature. If the concentration is inappropriate, sprayed washer fluid may freeze on the windshield and obstruct your view, and the fluid may freeze in the reservoir tank.**
- **State or local regulations on volatile organic compounds may restrict the use of methanol, a common windshield washer antifreeze additive. Washer fluids containing non-methanol antifreeze agents should be used only if they provide cold weather protection without damaging your vehicle's paint, wiper blades or washer system.**

▼ Before driving your vehicle

Before entering the vehicle, remove any snow or ice from your shoes because that

could make the pedals slippery and driving dangerous.

While warming up the vehicle before driving, check that the accelerator pedal, brake pedal, and all other controls operate smoothly.

Clear away ice and snow that has accumulated under the fenders to avoid making steering difficult. During severe winter driving, stop when and where it is safe to do so and check under the fenders periodically.

▼ Parking in cold weather

WARNING

Snow can trap dangerous exhaust gases under your vehicle. Keep snow clear of the exhaust pipe and from around your vehicle if you park the vehicle in snow with the engine running.

Do not use the parking brake when parking for long periods in cold weather since it could freeze in that position. Instead, you should observe the following tips.

1. Place the shift lever in "1" or "R" for MT models, or the select lever in "P" for AT models and CVT models.

2. Use tire stops under the tires to prevent the vehicle from moving.

When the vehicle is parked in snow or when it snows, raise the wiper blades off the glass to prevent damage to them.

When the vehicle has been left parked after use on roads heavily covered with snow, or has been left parked during a snowstorm, icing may develop on the brake system, which could cause poor braking action. Check for snow or ice buildup on the suspension, disc brakes and brake hoses underneath the vehicle. If there is caked snow or ice, remove it, being careful not to damage the disc brakes and brake hoses and ABS harness.

▼ Refueling in cold weather

To help prevent moisture from forming in the fuel system and the risk of its freezing, use of an antifreeze additive in the fuel tank is recommended during cold weather. Use only additives that are specifically designed for this purpose. When an antifreeze additive is used, its effect lasts longer if the tank is refilled whenever the fuel level reaches half empty.

If your SUBARU is not going to be used for an extended period, it is best to have the fuel tank filled to capacity.

■ Driving on snowy and icy roads

WARNING

Do not use the cruise control on slippery roads such as snowy or icy roads. This may cause loss of vehicle control.

CAUTION

Avoid prolonged continuous driving in snowstorms. Snow will enter the engine's intake system and may hinder the air flow, which could result in engine shutdown or even breakdown.

To prevent skidding and slipping, avoid sudden braking, abrupt acceleration, high-speed driving, and sharp turning when driving on snowy or icy roads.

Always maintain ample distance between your vehicle and the vehicle ahead of you to avoid the need for sudden braking.

To supplement the foot brake, use the engine brake effectively to control the vehicle speed. (Shift into a lower gear when necessary.)

Avoid shifting down abruptly. Such behavior can cause the wheels to lock, possibly

leading to loss of vehicle control.

An anti-lock brake system (ABS) enhances your vehicle's braking performance on snowy and icy roads. For information about braking on slippery surfaces, refer to "ABS (Anti-lock Brake System)" 7-25 and "Vehicle Dynamics Control system" 7-28.

▼ Wiper operation when snowing

Before driving in cold weather, make sure the wiper blades are not frozen to the windshield or rear window.

If the wiper blades are frozen to the windshield or rear window, perform the following procedure.

- To thaw the windshield wiper blades, use the defroster with the airflow selection in "☃" and the temperature set for maximum warmth until the wiper blades are completely thawed. Refer to "Climate control" 4-1.
- If your vehicle is equipped with a wiper deicer, use it. It is helpful to thaw the windshield wiper blades. Refer to "Defogger and deicer" 3-34.
- To thaw the rear wiper blade, use the rear window defogger. Refer to "Defogger and deicer" 3-34.

When driving in snow, if frozen snow starts to stick on the surface of the windshield

despite wiper operation, use the defroster with the airflow selection in "☃" and the temperature set for maximum warmth. After the windshield gets warmed enough to melt the frozen snow on it, wash it away using the windshield washer. Refer to "Windshield washer" 3-33

Snow stuck on the wiper arm prevents the wiper from working effectively. If snow is stuck on the wiper arm, pull off the road to a safe place, then remove it. If you stop the vehicle at road side, use the hazard warning flasher to alert other drivers. Refer to "Hazard warning flasher" 3-5.

We recommend use of non-freezing type wiper blades (winter blades) during the seasons you could have snow and freezing temperatures. Blades of this type give superior wiping performance in snowy conditions. Be sure to use blades that are suitable for your vehicle.

CAUTION

During high-speed driving, non-freezing type wiper blades may not perform as well as standard wiper blades. If this happens, reduce the vehicle speed.

NOTE

When the season requiring non-freezing type wiper blades is over, replace them with standard wiper blades.

■ Corrosion protection

Refer to "Corrosion protection" 10-4.

■ Snow tires

WARNING

- **When replacing original tires with winter (snow) tires, make sure you use only the same size, construction and load range as the original tires listed on the tire placard. Using other sizes and construction may affect speedometer/odometer calibration and clearance between the body and tires. It also may be dangerous and lead to loss of vehicle control.**
- **You must install four winter tires that are of the same size, circumferences, construction, brand, and load range. Mixing other sizes, circumferences or constructions may result in severe mechanical damage to the drive**

train of your vehicle and may affect ride, handling, braking and speedometer/odometer calibration. It also may be dangerous and lead to loss of vehicle control.

- Do not use a combination of radial, belted bias or bias tires since it may cause dangerous handling characteristics and lead to an accident.

▼ Except 2.5 L turbo models

Your vehicle is equipped with “all season tires” which are designed to provide an adequate measure of traction, handling and braking performance in year-round driving. In winter, it may be possible to enhance performance through use of tires designed specifically for winter driving conditions.

If you choose to install winter tires on your vehicle, be sure to use the correct tire size and type. You must install four winter tires that are of the same size, construction, brand and load range and you should never mix radial, belted bias or bias tires since this may result in dangerous handling characteristics. When you choose a tire, make sure that there is enough clearance between the tire and vehicle

body.

Remember to drive with care at all times regardless of the type of tires on your vehicle.

▼ 2.5 L turbo models

Your vehicle is equipped with “summer tires” as original equipment, which are inadequate for driving on slippery roads such as on snow-covered or icy roads.

Compared with winter and all-season tires, summer tires give significantly less grip on snowy and icy road surfaces. Therefore, use of winter tires is strongly recommended when driving with such road conditions.

When you choose to install winter tires on your vehicle, be sure to use the correct tire size and type. You must install four winter tires that are of the same size, construction, brand and load range and you should never mix radial, belted bias or bias tires since this may result in dangerous handling characteristics. When you choose a tire, make sure that there is enough clearance between the tire and vehicle body.

Remember to drive with care at all times regardless of the type of tires on your vehicle.

■ Tire chains



CAUTION

Tire chains cannot be used on any tires for your Legacy and Outback because of lack of clearance between the tires and vehicle body.

■ Rocking the vehicle

If you must rock the vehicle to free it from snow, sand, or mud, depress the accelerator pedal slightly and move the shift lever/select lever back and forth between “1”/“D” and “R” repeatedly. Do not race the engine. For the best possible traction, avoid spinning the wheels when trying to free the vehicle.

When the road surface is extremely slippery, you can obtain better traction by starting the vehicle with the transmission in 2nd than 1st (for MT, AT and CVT).

For information on holding the transmission in 2nd position, refer to “Selection of manual mode” ¶7-21.

Loading your vehicle

WARNING

Never allow passengers to ride on a folded rear seatback, in the trunk or in the cargo area. Doing so may result in serious injury.

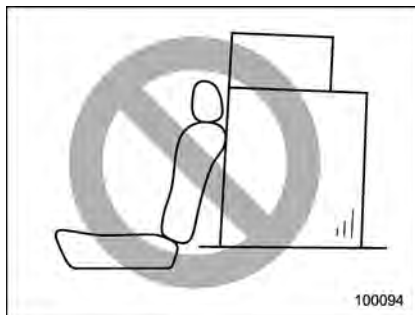

WARNING

- Never stack luggage or other cargo higher than the top of the seatback because it could tumble forward and injure passengers in the event of a sudden stop or accident. Keep luggage or cargo low, as close to the floor as

possible.

- When you carry something inside the vehicle, secure it whenever you can to prevent it from being thrown around inside the vehicle during sudden stops, sharp turns or in an accident.
- Do not pile heavy loads on the roof. These loads raise the vehicle's center of gravity and make it more prone to tip over.
- Secure lengthy items properly to prevent them from shooting forward and causing serious injury during a sudden stop.
- Never exceed the maximum load limit. If you do, some parts on your vehicle can break, or it can change the way your vehicle handles. This could result in loss of control and cause personal injury. Also, overloading can shorten the life of your vehicle.
- Do not place anything on the rear shelf behind the rear seatback (Legacy) or the extended luggage cover (Outback). Such items could tumble forward in the event of a sudden stop or a collision. This could cause serious injury.

CAUTION

Do not carry spray cans, containers with flammable or corrosive liquids or any other dangerous items inside the vehicle.

NOTE

For better fuel economy, do not carry unneeded cargo.

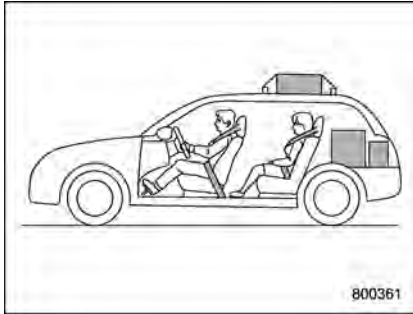
■ Vehicle capacity weight

800361

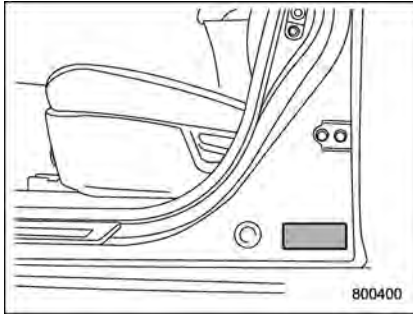

800400

The load capacity of your vehicle is determined by weight, not by available cargo space. The maximum load you can carry in your vehicle is shown on the vehicle placard attached to the driver's

side door pillar. It includes the total weight of the driver and all passengers and their belongings, any optional equipment such as a trailer hitch, roof rack or bike carrier, etc., and the tongue load of a trailer.

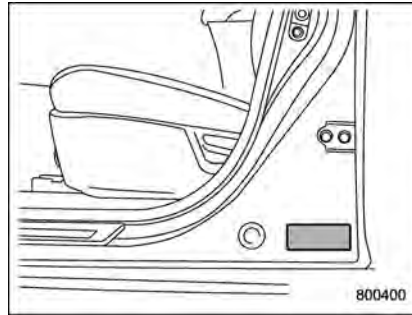
■ GVWR and GAWR (Gross Vehicle Weight Rating and Gross Axle Weight Rating)

800400

Certification label

The certification label attached to the driver's side door shows GVWR (Gross Vehicle Weight Rating) and GAWR (Gross Axle Weight Rating).

The GVW (Gross Vehicle Weight) must never exceed the GVWR. GVW is the combined total of weight of the vehicle, fuel, driver, all passengers, luggage, any

optional equipment and trailer tongue load. Therefore, the GVW changes depending on the situation.

In addition, the total weight applied to each axle (GAW) must never exceed the GAWR. The front and rear GAWs can be adjusted by relocating luggage inside the vehicle.

Even if the total weight of your luggage is lower than the vehicle capacity weight, either front or rear GAW may exceed the GAWR, depending on the distribution of the luggage.

When possible, the load should be evenly distributed throughout the vehicle.

If you carry heavy loads in the vehicle, you should confirm that GVW and front and rear GAWs are within the GVWR and GAWR by putting your vehicle on a vehicle scale, found at a commercial weighing station.

Do not use replacement tires with a lower load range than the originals because they may lower the GVWR and GAWR limitations. Replacement tires with a higher load range than the originals do not increase the GVWR and GAWR limitations.

■ Roof rails with integrated crossbars (Outback)

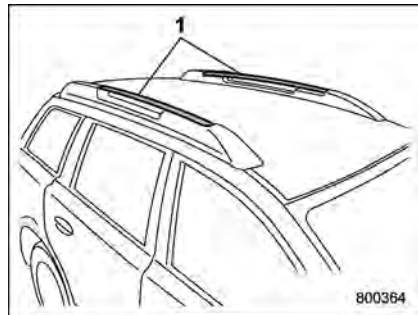

1) Integrated crossbars



CAUTION

- For cargo carrying purposes, the bars must be used as crossbars and be used together with the genuine SUBARU carrying attachment. The bars must never be used alone to carry cargo. Otherwise, damage to the roof or paint or a dangerous road hazard due to loss of cargo could result.
- When using the bars as crossbars, make sure that the total weight of the carrying attachment and cargo does not exceed

the maximum load limit. Overloading may cause damage to the vehicle and create a safety hazard.

The bars can be used as crossbars. Cargo can be carried after setting the bars as crossbars and installing the genuine SUBARU carrying attachment.

When you carry cargo on the roof using the crossbars and a carrying attachment, never exceed the maximum load limit explained in the following. You should also be careful that your vehicle does not exceed the Gross Vehicle Weight Rating (GVWR) and front and rear Gross Axle Weight Rating (GAWR). For information on loading cargo into or onto your vehicle, refer to "Loading your vehicle" 8-12. The maximum load limit of the cargo and carrying attachment must not exceed the allowable load limit described in the Owner's Manual of a genuine SUBARU carrying attachment. Place the heaviest load at the bottom, nearest the roof, and evenly distribute the cargo. Always properly secure all cargo.

▼ Installing carrying attachments on the crossbars

When installing any carrying attachment such as a bike carrier, ski carrier, kayak carrier, cargo basket, etc. on the crossbars, follow the manufacturer's instructions and make sure that the attachment is securely fixed to the crossbars. Use only genuine SUBARU attachments. A set of the crossbars is designed to carry loads (cargo and attachment) of not more than the allowable load limit described in the Owner's Manual of a genuine SUBARU carrying attachment. Before operating the vehicle, make sure that the cargo is properly secured on the attachment.

NOTE

- Remember that the vehicle's center of gravity is altered with the weight of the load on the roof, thus affecting the driving characteristics. Drive carefully, avoid rapid starts, hard cornering and abrupt stops. Crosswind effects will be increased.
- Restore the bars to the original position when the bars are not used as crossbars.

▼ How to use as crossbars

CAUTION

- Do not raise the bar higher than necessary. The base of the bar may be damaged.
- Be careful not to contact the bars while sliding them. Otherwise, the bars may be scratched or the latch portions may be damaged.
- Do not slide the bar more than necessary when sliding the bar. The base of the bar may be damaged.
- Do not allow the bar to fall on or contact the roof panel or the moonroof when sliding the bar. Otherwise the roof panel may be dented or the glass of the moonroof may be damaged.



1. Pull out the integrated crossbars from the roof rail holders by pulling up the covers.

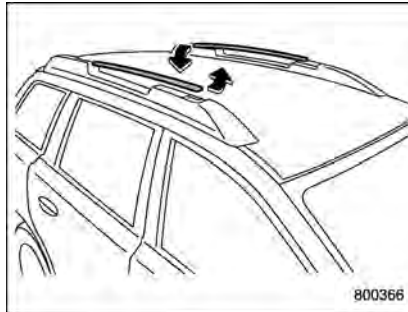

2. Slide the bars in the direction shown in the illustration.

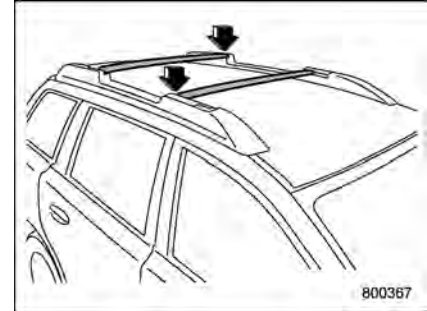

3. Install the bars into the holders.
4. Make sure that the latches are fitted securely.

▼ How to restore bars

CAUTION

Do not use the bars as roof rails when the bars are restored.



1. Pull out the crossbars from the roof rail holders by pulling up the covers.

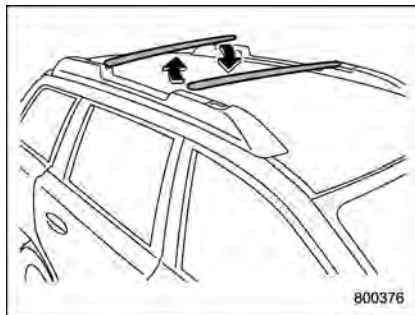

2. Slide the bars in the direction shown in the illustration.

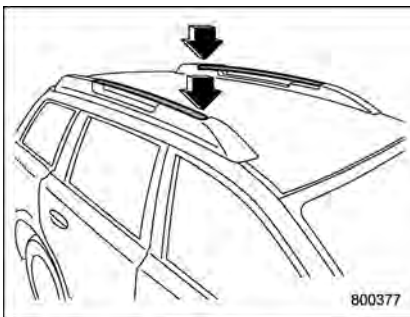

3. Install the bars into the holders.
4. Make sure that the latches are fitted securely.

Trailer hitch (Outback — if equipped)

WARNING

- Never exceed the maximum weight specified for the trailer hitch. Exceeding the maximum weight could cause an accident resulting in serious personal injuries. Permissible trailer weight changes depending on the situation. For possible recommendations and limitations, refer to “Trailer towing” 8-19.
- Trailer brakes are required when the towing load exceeds 1,000 lbs (453 kg). Be sure your trailer has safety chains and that each chain will hold the trailer’s maximum gross weight. Towing trailers without safety chains could create a traffic safety hazard if the trailer separates from the hitch due to coupling damage or hitch ball damage.
- Be sure to check the hitch pin and safety pin for positive locking placement before towing a trailer. If the ball mount comes off the hitch receiver, the trailer

could get loose and create a traffic safety hazard.

- Use only the ball mount supplied with this hitch. Use the hitch only as a weight carrying hitch. Do not use with any type of weight distributing hitch.

The trailer hitch is designed to tow a Class 1 rated load. The maximum gross trailer weight and maximum gross tongue weight are indicated in the following table.

| | Maximum gross trailer weight | Maximum gross tongue weight |
|------------------------------------|------------------------------|-----------------------------|
| 3.6 L models | 3,000 lbs (1,360 kg) | 200 lbs (90 kg) |
| All models other than 3.6 L models | 2,700 lbs (1,224 kg) | |

When you tow a trailer, refer to "Trailer towing" 8-19.

■ Connecting a trailer

1. Remove the receiver cover from the hitch receiver tube. Then insert the ball mount into the hitch receiver tube.

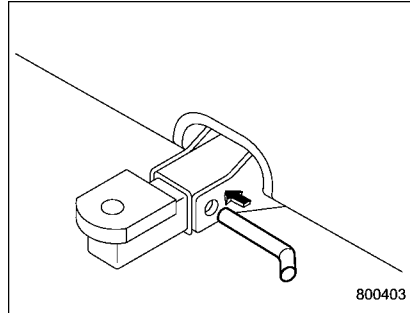

2. Insert the hitch pin into the hole on the hitch receiver tube so that the pin passes through the ball mount.

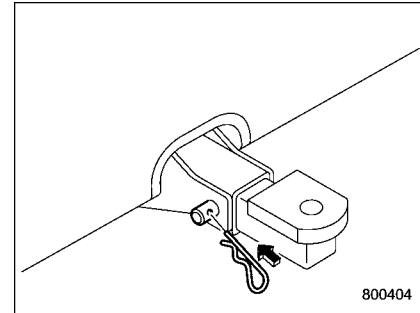

3. Insert the safety pin onto the hitch pin securely.
4. Pull the ball mount to make sure it does not come off the hitch receiver.

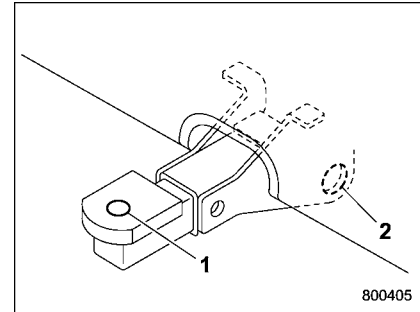

- 1) Hitch ball installation point
- 2) Hooks for safety chains

5. Use only a hitch ball that is appropriate for the ball mount and your trailer. The hitch ball must be securely installed on the ball mount.
6. Connect your trailer to the hitch ball.
7. Connect the trailer and the hitch with safety chains that will hold the trailer's maximum gross weight. The chains should cross under the trailer tongue to prevent the tongue from dropping onto the ground in case it should disconnect from the hitch ball. Allow sufficient slack in the chains taking tight-turn situations into account; however, be careful not to let them drag on the ground.



WARNING

Do not connect safety chains to part of the vehicle other than the safety chain hooks.

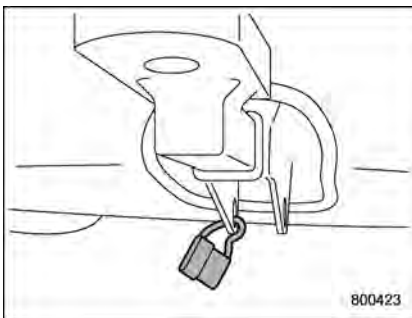

Hitch harness connector

8. Connect the hitch wire harness's black four-pin wire connector to the towing trailer's wire harness.
9. Confirm proper function of the hitch wire harness by individually activating the brake, stop and turn signal lights on the trailer.

NOTE

Always disconnect the trailer wire harness before launching or retrieving a watercraft.

■ **When you do not tow a trailer**

- Remove the ball mount from the hitch receiver tube and insert the receiver cover onto the hitch receiver tube.
- Place the dust cap over the four-pin connector of the hitch wire harness to protect against possible damage.
- Occasionally lubricate terminals of the four-pin connector using terminal grease.

Trailer towing

Your vehicle is designed and intended to be used primarily as a passenger-carrying vehicle. Towing a trailer puts additional loads on your vehicle's engine, drivetrain, brakes, tires and suspension and has an adverse effect on fuel economy.

If you do decide to tow a trailer, your safety and satisfaction depend upon proper use of correct equipment and cautious operation of your vehicle. Seek the advice of your SUBARU dealer to assist you in purchasing a hitch and other necessary towing equipment appropriate for your vehicle. In addition, be sure to follow the instructions on correct installation and use provided by the trailer and other towing equipment manufacturers.

SUBARU assumes no responsibility for injuries or vehicle damage that result from trailer towing equipment, or from any errors or omissions in the instructions accompanying such equipment or for your failure to follow the proper instructions.

■ Warranties and maintenance

SUBARU warranties do not apply to vehicle damage or malfunction caused by trailer towing. If you use your vehicle to tow a trailer, more frequent maintenance will be required due to the additional load.

(Refer to "Maintenance schedule under severe driving conditions" in the "Warranty and Maintenance Booklet".)

Under no circumstances should a trailer be towed with a new vehicle or a vehicle with any new powertrain component (engine, transmission, differential, wheel bearings, etc.) for the first 1,000 miles (1,600 km) of driving.

■ Maximum load limits

WARNING

Never exceed the maximum load limits explained in the following. Exceeding the maximum load limits could cause personal injury and/or vehicle damage.

CAUTION

- Adequate size trailer brakes are required when the trailer and its cargo exceed 1,000 lbs (453 kg) total weight.
- Before towing a trailer, check the trailer total weight, GVW, GAWs and tongue load. Make sure the load and its distribution in your vehicle and trailer are accepta-

ble.

▼ Total trailer weight

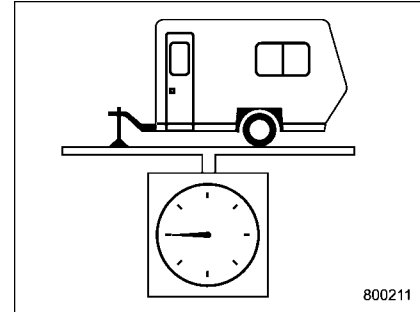

Total trailer weight

The total trailer weight (trailer weight plus its cargo load) must never exceed the maximum weight.

▽ Legacy

The total trailer weight must not exceed 1,000 lbs (453 kg).

▽ Outback

The maximum total trailer weight is indicated in the following tables.

3.6 L models

| Conditions | Maximum total trailer weight |
|---|------------------------------|
| When towing a trailer without brakes. | 1,000 lbs (453 kg) |
| When towing a trailer with brakes. | 3,000 lbs (1,360 kg) |
| When towing a trailer on a long uphill grade continuously for over 5 miles (8 km) with an outside temperature of 104°F (40°C) or above. | 1,500 lbs (680 kg) |

All models other than 3.6 L models

| Model | Conditions | Maximum total trailer weight |
|------------|---|------------------------------|
| MT models | When towing a trailer without brakes. | 1,000 lbs (453 kg) |
| | When towing a trailer with brakes. | 2,700 lbs (1,224 kg) |
| CVT models | When towing a trailer without brakes. | 1,000 lbs (453 kg) |
| | When towing a trailer with brakes. | 2,700 lbs (1,224 kg) |
| | When towing a trailer on a long uphill grade continuously for over 5 miles (8 km) with an outside temperature of 104°F (40°C) or above. | 1,350 lbs (612 kg) |

▼ Gross Vehicle Weight (GVW) and Gross Vehicle Weight Rating (GVWR)

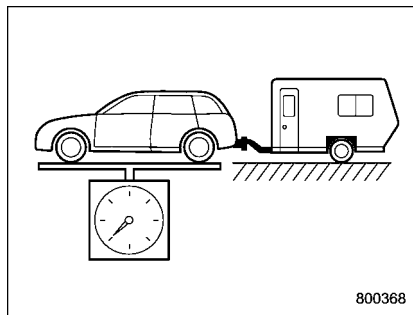

Gross Vehicle Weight

The Gross Vehicle Weight (GVW) must never exceed the Gross Vehicle Weight Rating (GVWR).

Gross Vehicle Weight (GVW) is the combined total of the weight of the vehicle, driver, passengers, luggage, trailer hitch, trailer tongue load and any other optional equipment installed on your vehicle. Therefore, the GVW changes depending on the situation. Determine the GVW each time before going on a trip by putting your vehicle and trailer on a vehicle scale.

GVWR is shown on the certification label located on the driver's door of your vehicle.

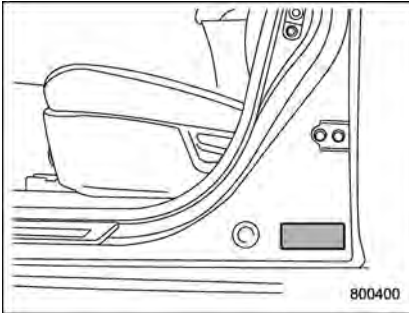

Certification label

▼ Gross Axle Weight (GAW) and Gross Axle Weight Rating (GAWR)

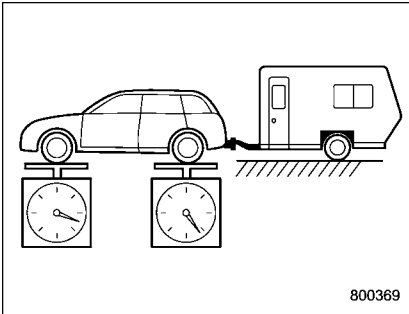

Gross Axle Weight

The total weight applied to each axle (GAW) must never exceed the Gross Axle Weight Rating (GAWR). The front and rear GAWs can be adjusted by relocating passengers and luggage inside the vehicle. The front and rear GAWR are also shown on the certification label.

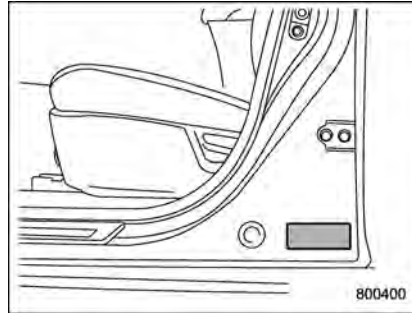

Certification label

To check both GVWR and GAWR and to confirm that the total weight and weight distribution are within safe driving limits, you should have your vehicle and trailer weighed at a commercial weighing station. Be sure that all cargo is firmly secured to prevent a change in weight distribution while driving.

▼ Tongue load

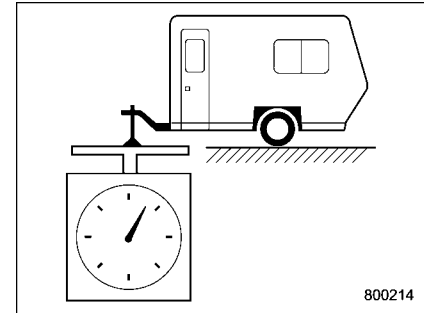

Tongue load

▲ WARNING

If the trailer is loaded with more weight in the back of trailer's axle than in the front, the load is taken off the rear axle of the towing vehicle. This may cause the rear wheels to skid, especially during braking or when vehicle speed is reduced during cornering, resulting in oversteer, spin out and/or jackknifing.

Ensure that the trailer tongue load is from 8 to 11 percent of the total trailer weight and does not exceed the maximum value of 200 lbs (90 kg).

NOTE

For vehicles with trailer brakes, the trailer tongue load exceeds 200 lbs (90 kg) when calculated at 8% of the maximum total trailer weight. Even in this case, the maximum value is 200 lbs (90 kg).

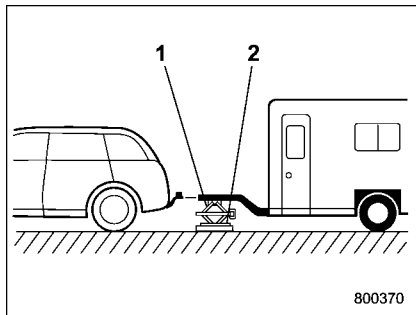

- 1) Jack
- 2) Bathroom scale

The tongue load can be weighed with a bathroom scale as shown in the following illustration. When weighing the tongue load, be sure to position the towing coupler at the height at which it would be during actual towing, using a jack as shown.

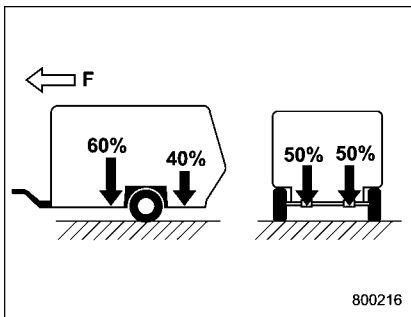

F: Front

The tongue load can be adjusted by proper distribution of the load in the trailer. Never load the trailer with more weight in the back than in the front; approximately 60 percent of the trailer load should be in the front and approximately 40 percent in the rear. Also, distribute the load as evenly as possible on both the left and right sides.

Be sure that all cargo is firmly secured to prevent a change in weight distribution while driving.

■ Trailer hitches

WARNING

Never drill the frame or under-body of your vehicle to install a commercial trailer hitch. If you do, dangerous exhaust gas, water or mud may enter the passenger compartment through the drilled hole. Exhaust gas contains carbon monoxide, a colorless and odorless gas which is dangerous, or even lethal, if inhaled. Also, drilling the frame or under-body of your vehicle could cause deterioration of strength of your vehicle and cause corrosion around the drilled hole.

CAUTION

- Do not modify the vehicle exhaust system, brake system, or other systems when installing a hitch or other trailer towing equipment.
- Do not use axle-mounted hitches as they can cause damage to the axle housing, wheel bearings, wheels or tires.

Choose a proper hitch for your vehicle and

trailer.

▼ **Outback**

The use of a genuine SUBARU trailer hitch is recommended. A genuine SUBARU hitch is available from your SUBARU dealer.

If use of a non-genuine hitch is unavoidable, be sure the hitch is suited to your vehicle and trailer. Consult with a professional hitch supplier to assist you in choosing an appropriate hitch for your vehicle. Be sure to follow all of the hitch manufacturer's instructions for installation and use.

Never use a hitch that mounts only to the rear bumper. The bumper is not designed to handle that type of load.

For all types of hitches, regularly check that the hitch mounting bolts and nuts are tight.

▼ **Legacy**

SUBARU does not offer accessory trailer hitches. Consult with a professional hitch supplier to assist you in choosing an appropriate hitch for your vehicle. Be sure to follow all of the hitch manufacturer's instructions for installation and use.

Never use a hitch that mounts only to the rear bumper. The bumper is not designed to handle that type of load.

Regularly check that the hitch mounting bolts and nuts are tight.

■ **Connecting a trailer**

▼ **Trailer brakes**

WARNING

- **Adequate size trailer brakes are required when the trailer and its cargo exceed 1,000 lbs (453 kg) total weight.**
- **Do not directly connect your trailer's hydraulic brake system to the hydraulic brake system in your vehicle. Direct connection would cause the vehicle's brake performance to deteriorate and could lead to an accident.**

If your trailer's total weight (trailer weight plus its cargo weight) exceeds 1,000 lbs (453 kg), the trailer is required to be equipped with its own brake system. Electric brakes or surge brakes are recommended, and must be installed properly. Check that your trailer's brakes conform with Federal, state/province and/or other applicable regulations. Your SUBARU's brake system is not designed to be tapped into the trailer's hydraulic brake system. Please ask your SUBARU

dealer and professional trailer supplier for more information about the trailer's brake system.

▼ **Trailer safety chains**

WARNING

Always use safety chains between your vehicle and the trailer. Towing trailer without safety chains could create a traffic safety hazard if the trailer separates from the hitch due to coupling damage or hitch ball damage.

In case the trailer hitch connector or hitch ball should break or become disconnected, the trailer could get loose and create a traffic safety hazard.

For safety, always connect the towing vehicle and trailer with trailer safety chains. Pass the chains crossing each other under the trailer tongue to prevent the trailer from dropping onto the ground in case the trailer tongue should disconnect from the hitch ball. Allow sufficient slack in the chains taking tight-turn situations into account; however, be careful not to let them drag on the ground.

For more information about the safety chain connection, refer to the instructions for your hitch and trailer.

▼ Side mirrors

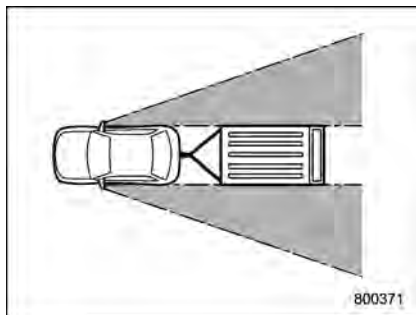

After hitching a trailer to your vehicle, check that the standard side mirrors provide a good rearward field of view without significant blind spots. If significant blind spots occur with the vehicle's standard side mirrors, use towing mirrors that conform with Federal, state/province and/or other applicable regulations.

▼ Trailer lights

CAUTION

Direct splicing or other improper connection of trailer lights may damage your vehicle's electrical system and cause a malfunction of your vehicle's lighting system.

Connection of trailer lights to your vehicle's electrical system requires modifications to the vehicle's lighting circuit to increase its capacity and accommodate wiring changes. To ensure the trailer lights are connected properly, please consult your SUBARU dealer. Check for proper operation of the turn signals and the brake lights each time you hitch up.

▼ Tires

WARNING

Never tow a trailer when the temporary spare tire is used. The temporary spare tire is not designed to sustain the towing load. Use of the temporary spare tire when towing can result in failure of the spare tire and/or less stability of the vehicle.

Make sure that all the tires on your vehicle are properly inflated. Refer to "Tires" 12-5 and in "GAS STATION REFERENCE" at the end of this manual.

Trailer tire condition, size, load rating and proper inflation pressure should be in accordance with the trailer manufacturer's specifications.

In the event your vehicle gets a flat tire when towing a trailer, ask a commercial

road service to repair the flat tire.

If you carry a regular size spare tire in your vehicle or trailer as a precaution against getting a flat tire, be sure that the spare tire is firmly secured.

■ Trailer towing tips

CAUTION

- Never exceed 45 mph (72 km/h) when towing a trailer in hilly country on hot days.
- When towing a trailer, steering, stability, stopping distance and braking performance will be different from normal operation. For safety's sake, you should employ extra caution when towing a trailer and you should never speed. You should also keep the following tips in mind:

▼ Before starting out on a trip

- Check that the vehicle and vehicle-to-hitch mounting are in good condition. If any problems are apparent, do not tow the trailer.
- Check that the vehicle sits horizontally with the trailer attached. If the vehicle is tipped sharply up at the front and down at

the rear, check the total trailer weight, GVW, GAWs and tongue load again, then confirm that the load and its distribution are acceptable.

- Check that the tire pressures are correct.
- Check that the vehicle and trailer are connected properly. Confirm that
 - the trailer tongue is connected properly to the hitch ball.
 - the trailer lights connector is connected properly and trailer's brake lights illuminate when the vehicle's brake pedal is pressed, and that the trailer's turn signal lights flash when the vehicle's turn signal lever is operated.
 - the safety chains are connected properly.
 - all cargo in the trailer is secured safely in position.
 - the side mirrors provide a good rearward field of view without a significant blind spot.
- Sufficient time should be taken to learn the "feel" of the vehicle/trailer combination before starting out on a trip. In an area free of traffic, practice turning, stopping and backing up.

▼ Driving with a trailer

- You should allow for considerably more stopping distance when towing a trailer. Avoid sudden braking because it may result in skidding or jackknifing and loss of control.
- Avoid abrupt starts and sudden accelerations. If your vehicle has a manual transmission, always start out in first gear and release the clutch at moderate engine revolution.
- Avoid uneven steering, sharp turns and rapid lane changes.
- Slow down before turning. Make a longer than normal turning radius because the trailer wheels will be closer than the vehicle wheels to the inside of the turn. In a tight turn, the trailer could hit your vehicle.
- Crosswinds will adversely affect the handling of your vehicle and trailer, causing sway. Crosswinds can be due to weather conditions or the passing of large trucks or buses. If swaying occurs, firmly grip the steering wheel and slow down immediately but gradually.
- When passing other vehicles, considerable distance is required because of the added weight and length caused by attaching the trailer to your vehicle.

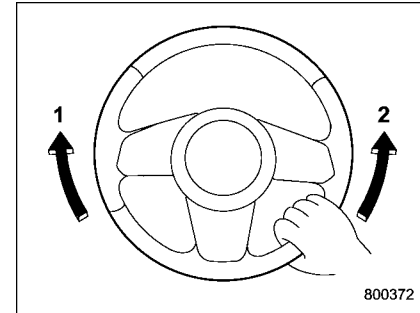

- 1) Left turn
- 2) Right turn

- Backing up with a trailer is difficult and takes practice. When backing up with a trailer, never accelerate or steer rapidly. When turning back, grip the bottom of the steering wheel with one hand and turn it to the left for a left turn, and turn it to the right for a right turn.
- If the ABS warning light illuminates while the vehicle is in motion, stop towing the trailer and have repairs performed immediately by the nearest SUBARU dealer.

▼ Driving on grades

- Before going down a steep hill, slow down and shift into lower gear (if necessary, use 1st gear) in order to utilize the

engine braking effect and prevent overheating of your vehicle's brakes. Do not make sudden downshifts.

- When driving uphill in hot weather, the air conditioner may turn off automatically to protect the engine from overheating.
- When driving uphill in hot weather, pay attention to the coolant temperature high warning light (for all models) and AT OIL TEMP warning light (for AT and CVT models) because the engine and transmission are relatively prone to overheating under these conditions. If the coolant temperature high warning light and/or the AT OIL TEMP warning light illuminates, immediately turn off the air conditioner and stop the vehicle in the nearest safe location. For further instructions and additional information, refer to the following sections.

- “If you park your vehicle in an emergency” 9-2
- “Engine overheating” 9-12
- “Coolant temperature low indicator light/Coolant temperature high warning light” 3-13

– “AT OIL TEMP warning light (AT and CVT models)” 3-15

- For AT and CVT models, avoid using the accelerator pedal to stay stationary on an uphill slope instead of using the parking brake or foot brake. That may cause the transmission fluid to overheat.

▼ **Parking on a grade**

Always block the wheels under both vehicle and trailer when parking. Apply the parking brake firmly. You should not park on a hill or slope. But if parking on a hill or slope cannot be avoided, you should take the following steps:

1. Apply the brakes and hold the pedal down.
2. Have someone place wheel blocks under both the vehicle and trailer wheels.
3. When the wheel blocks are in place, release the regular brakes slowly until the blocks absorb the load.
4. Apply the regular brakes and then apply the parking brake; slowly release the regular brakes.
5. Shift into 1st or reverse gear (MT models) or “P” (AT and CVT models) and shut off the engine.

| | | | |
|---|------|--|------|
| If you park your vehicle in an emergency | 9-2 | If no steam is coming from the engine compartment | 9-12 |
| Temporary spare tire | 9-2 | Towing | 9-12 |
| Maintenance tools | 9-3 | Towing and tie-down hooks | 9-13 |
| Legacy | 9-4 | Using a flat-bed truck | 9-15 |
| Outback | 9-5 | Towing with all wheels on the ground | 9-15 |
| Flat tires | 9-6 | Electronic parking brake – if the electronic parking brake cannot be released | 9-16 |
| Changing a flat tire | 9-6 | Trunk lid (Legacy) – if the trunk lid cannot be opened | 9-19 |
| Tire pressure monitoring system (TPMS) (if equipped) | 9-9 | Rear gate (Outback) – if the rear gate cannot be unlocked | 9-19 |
| Jump starting | 9-10 | Moonroof – if moonroof cannot be closed | 9-20 |
| How to jump start | 9-10 | | |
| Engine overheating | 9-12 | | |
| If steam is coming from the engine compartment | 9-12 | | |

If you park your vehicle in an emergency

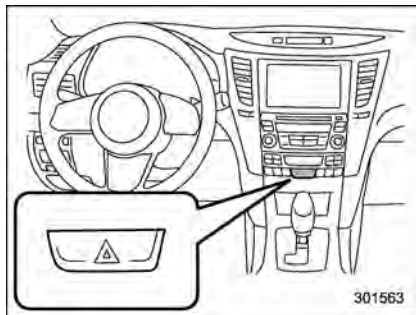

The hazard warning flasher should be used in day or night to warn other drivers when you have to park your vehicle under emergency conditions.

Avoid stopping on the road. It is best to safely pull off the road if a problem occurs.

The hazard warning flasher can be activated regardless of the ignition switch position.

Turn on the hazard warning by pressing the hazard warning flasher switch. Turn it off by pressing the switch again.

NOTE

When the hazard warning flasher is on, the turn signals do not work.

Temporary spare tire



WARNING

- Never tow a trailer when the temporary spare tire is used. The temporary spare tire is not designed to sustain the towing load. Use of the temporary spare tire when towing can result in failure of the spare tire and/or less stability of the vehicle and may lead to an accident.
- When a spare tire is mounted or a wheel rim is replaced without the original pressure sensor/transmitter being transferred, the low tire pressure warning light will illuminate steadily after blinking for approximately one minute. This indicates the tire pressure monitoring system (TPMS) is unable to monitor all four road wheels. Contact your SUBARU dealer as soon as possible for tire and sensor replacement and/or system resetting.

CAUTION

Never use any temporary spare tire other than the original. Using other sizes may result in severe mechanical damage to the drive train of your vehicle.

The temporary spare tire is smaller and lighter than a conventional tire and is designed for emergency use only. Remove the temporary spare tire and re-install the conventional tire as soon as possible because the spare tire is designed only for temporary use.

Check the inflation pressure of the temporary spare tire periodically to keep the tire ready for use. The correct pressure is **60 psi (420 kPa, 4.2 kgf/cm²)**.

When using the temporary spare tire, note the following precautions.

- Do not exceed 50 mph (80 km/h).
- Do not put a tire chain on the temporary spare tire. Because of the smaller tire size, a tire chain will not fit properly.
- Do not use two or more temporary spare tires at the same time.
- Do not drive over obstacles. This tire has a smaller diameter, so road clearance is reduced.

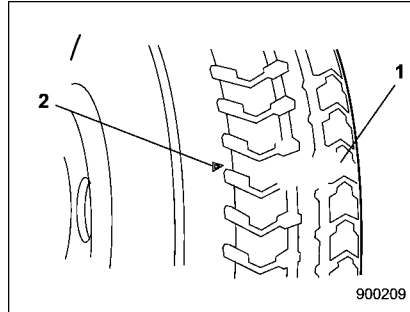

- 1) Tread wear indicator bar
- 2) Indicator location mark

- When the wear indicator appears on the tread, replace the tire.
- The temporary spare tire must be used only on a rear wheel. If a front wheel tire gets punctured, replace the wheel with a rear wheel and install the temporary spare tire in place of the removed rear wheel.

Maintenance tools

Your vehicle is equipped with the following maintenance tools.

- Jack
- Jack handle
- Screwdriver
- Towing hook (eye bolt)
- Wheel nut wrench
- Electronic parking brake release tool

■ Legacy

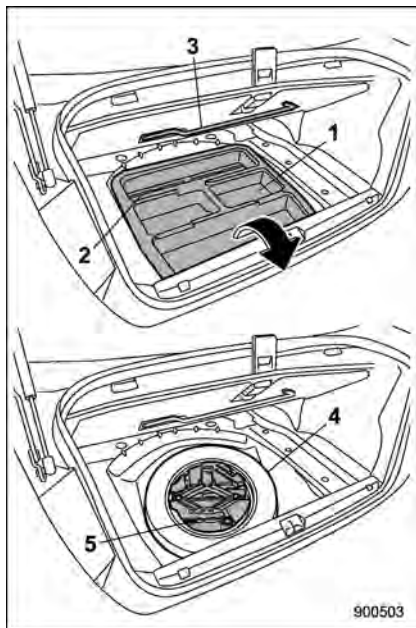

- 1) Under-floor storage compartment (Refer to "Under-floor storage compartment" 9-6-18.)
- 2) Electronic parking brake release tool
- 3) Jack handle
- 4) Spare tire

5) Tool bucket

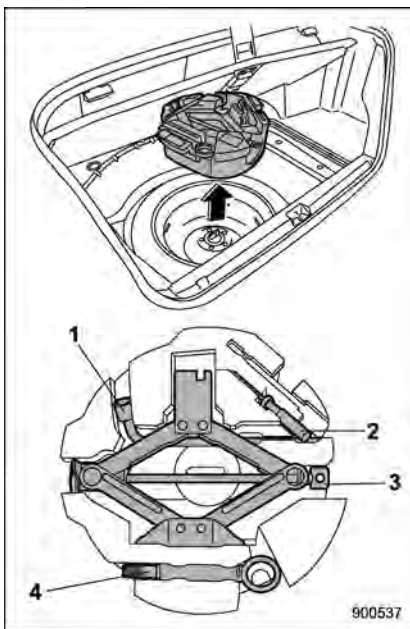

- 1) Wheel nut wrench
- 2) Screwdriver
- 3) Jack
- 4) Towing hook (eye bolt)

The jack handle is stored on the back of

the floor cover of the trunk. The electronic parking brake release tool is stored under the floor of the trunk. The other tools are stored in the tool bucket that is located in the recess of the spare tire wheel.

For the method to use the jack, refer to "Flat tires" 9-6.

For the method to use the electronic parking brake release tool, refer to "Electronic parking brake – if the electronic parking brake cannot be released" 9-16.

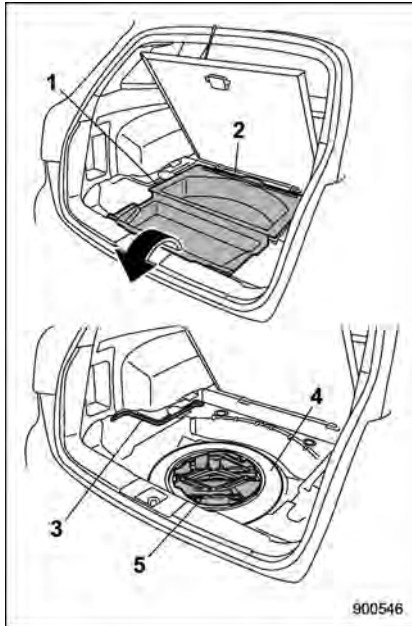
Outback

- 1) Under-floor storage compartment (Refer to "Under-floor storage compartment" 9-6-18.)
- 2) Electronic parking brake release tool
- 3) Jack handle
- 4) Spare tire

5) Tool bucket

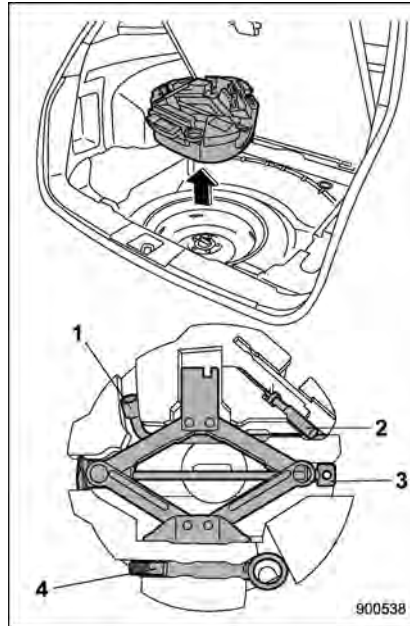

- 1) Wheel nut wrench
- 2) Screwdriver
- 3) Jack
- 4) Towing hook (eye bolt)

The jack handle is stored under the cargo

area. The electronic parking brake release tool is stored under the floor of the cargo area. The other tools are stored in the tool bucket that is located in the recess of the spare tire wheel.

For the method to use the jack, refer to "Flat tires" 9-6.

For the method to use the electronic parking brake release tool, refer to "Electronic parking brake – if the electronic parking brake cannot be released" 9-16.

Flat tires

If you have a flat tire while driving, never brake suddenly; keep driving straight ahead while gradually reducing speed. Then slowly pull off the road to a safe place.

■ Changing a flat tire

WARNING

- Do not jack up the vehicle on an incline or a loose road surface. The jack can come out of the jacking point or sink into the ground and this can result in a serious accident.
- Use only the jack provided with your vehicle. The jack supplied with the vehicle is designed only for changing a tire. Never get under the vehicle while supporting the vehicle with this jack.

- Always turn off the engine before raising the flat tire off the ground using the jack. Never swing or push the vehicle supported with the jack. The jack can come out of the jacking point due to a jolt and this can result in a serious accident.

1. Park on a hard, level surface, whenever possible, then stop the engine.
2. Apply the parking brake securely and shift the shift lever in reverse (MT models) or the select lever in the "P" (Park) position (AT and CVT models).
3. Turn on the hazard warning flasher and have everyone get out of the vehicle.

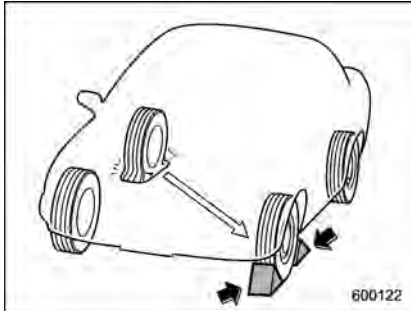

4. Put wheel blocks at the front and rear of the tire diagonally opposite the flat tire.

5. Take out the jack, jack handle and wheel nut wrench.

The tools and the spare tire are stored under the floor of the trunk (Legacy) or the cargo area (Outback). Refer to "Maintenance tools" 9-3.

NOTE

Make sure that the jack is well lubricated before using it.

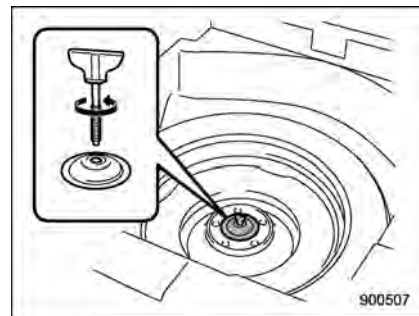

Legacy

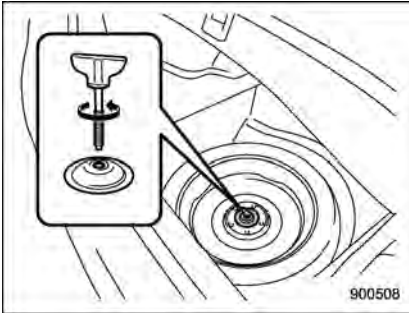
**Outback**

6. Take out the tool bucket and turn the attaching bolt counterclockwise, then take the spare tire out.

NOTE

If the spare tire provided in your vehicle is a temporary spare tire, carefully read "Temporary spare tire" 9-2 and strictly follow the instructions.

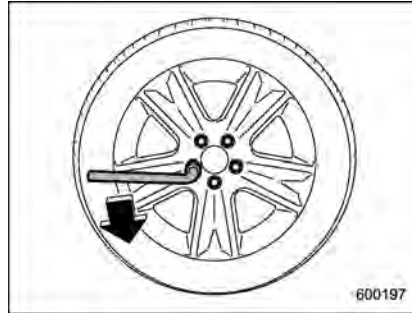

7. Loosen the wheel nuts using the wheel nut wrench but do not remove the nuts.

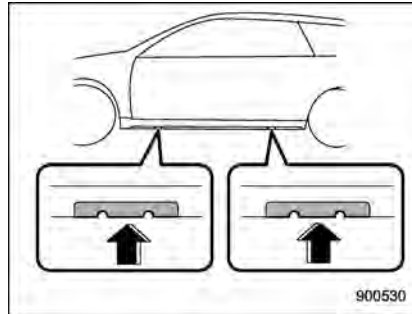

8. Place the jack under the side sill at the front or rear jack-up point closest to the flat tire.

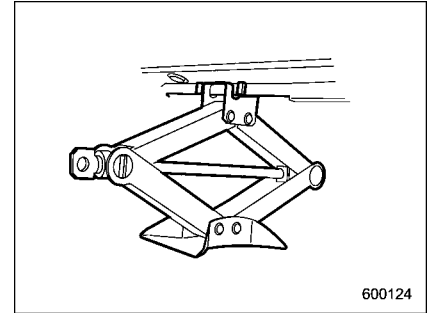

Turn the jackscrew by hand until the jack head engages firmly into the jack-up point.

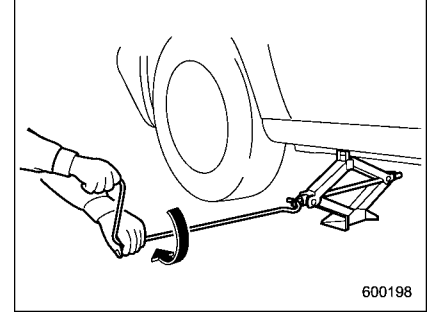

9. Insert the jack handle into the jackscrew, and turn the handle until the tire clears the ground. Do not raise the vehicle higher than necessary.

10. Remove the wheel nuts and the flat tire.

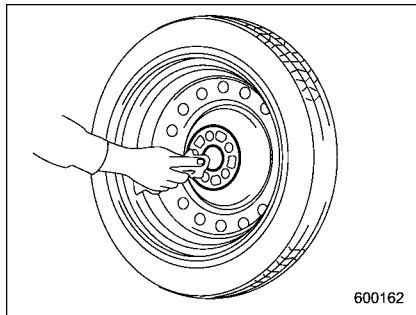
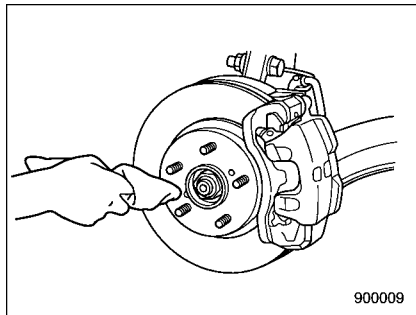

11. Before putting the spare tire on, clean the mounting surface of the wheel and hub with a cloth.

12. Put on the spare tire. Replace the

wheel nuts. Tighten them by hand.

WARNING

Do not use oil or grease on the wheel studs or nuts when the spare tire is installed. This could cause the nuts to become loose and lead to an accident.

13. Turn the jack handle counterclockwise to lower the vehicle.

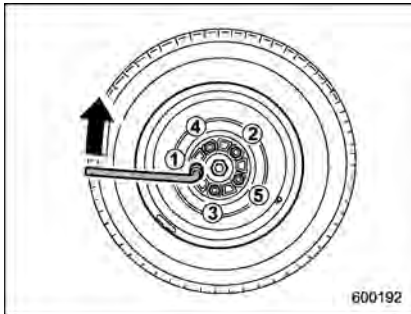

14. Use the wheel nut wrench to securely tighten the wheel nuts to the specified torque, following the tightening order in the illustration.

The torque for tightening the nuts is 89 lbf-ft (120 N·m, 12 kgf·m). This torque is equivalent to applying approximately 110

lbs (50 kg) at the top of the wheel nut wrench. Never use your foot on the wheel nut wrench or a pipe extension on the wrench because you may exceed the specified torque. Have the wheel nut torque checked at the nearest automotive service facility.

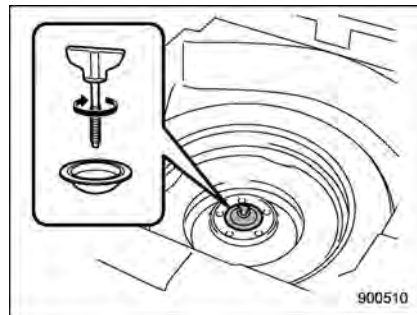

15. Store the flat tire in the spare tire compartment.

Put the spacer and tighten the attaching bolt firmly.

Also store the jack and jack handle in their storage locations.

⚠ WARNING

Never place a tire or tire changing tools in the passenger compartment after changing wheels. In a sudden stop or collision, loose equipment could strike occupants and cause injury. Store the tire and all tools in the proper place.

■ Tire pressure monitoring system (TPMS) (if equipped)

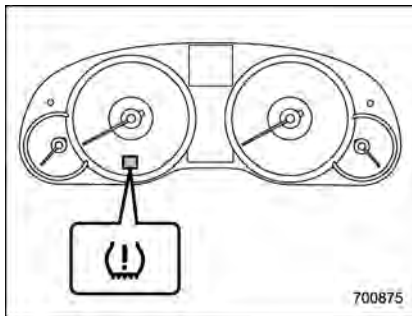

The tire pressure monitoring system provides the driver with the warning message indicated by sending a signal from a sensor that is installed in each wheel when tire pressure is severely low.

The tire pressure monitoring system will

activate only when the vehicle is driven. Also, this system may not react immediately to a sudden drop in tire pressure (for example, a blow-out caused running over a sharp object).

⚠ WARNING

If the low tire pressure warning light illuminates while driving, never brake suddenly and keep driving straight ahead while gradually reducing speed. Then slowly pull off the road to a safe place. Otherwise an accident involving serious vehicle damage and serious personal injury could occur.

Check the pressure for all four tires and adjust the pressure to the COLD tire pressure shown on the vehicle placard on the door pillar on the driver's side. If this light still illuminates while driving after adjusting the tire pressure, a tire may have significant damage and a fast leak that causes the tire to lose air rapidly. If you have a flat tire, replace it with a spare tire as soon as possible.

When a spare tire is mounted or a wheel rim is replaced without the original pressure sensor/transmitter

being transferred, the low tire pressure warning light will illuminate steadily after blinking for approximately one minute. This indicates the TPMS is unable to monitor all four road wheels. Contact your SUBARU dealer as soon as possible for tire and sensor replacement and/or system resetting.

Do not inject any tire liquid or aerosol tire sealant into the tires, as this may cause a malfunction of the tire pressure sensors.

If the light illuminates steadily after blinking for approximately one minute, promptly contact a SUBARU dealer to have the system inspected.

Jump starting



WARNING

- **Battery fluid is SULFURIC ACID. Do not let it come in contact with the eyes, skin, clothing or the vehicle.**

If battery fluid gets on you, thoroughly flush the exposed area with water immediately. Get medical help if the fluid has entered your eyes.

If battery fluid is accidentally swallowed, immediately drink a large amount of milk or water, and obtain immediate medical help.

Keep everyone including children away from the battery.

- **The gas generated by a battery explodes if a flame or spark is brought near it. Do not smoke or light a match while jump starting.**
- **Never attempt jump starting if the discharged battery is frozen. It could cause the battery to burst or explode.**
- **Whenever working on or around a battery, always wear suitable**

eye protectors, and remove metal objects such as rings, bands or other metal jewelry.

- **Be sure the jumper cables and clamps on them do not have loose or missing insulation.**
- **Do not jump start unless cables in suitable condition are available.**
- **A running engine can be dangerous. Keep your fingers, hands, clothing, hair and tools away from the cooling fan, belts and any other moving engine parts. Removing rings, watches and ties is advisable.**
- **Jump starting is dangerous if it is done incorrectly. If you are unsure about the proper procedure for jump starting, consult a competent mechanic.**

When your vehicle does not start due to a run down (discharged) battery, the vehicle may be jump started by connecting your battery to another battery (called the booster battery) with jumper cables.

■ How to jump start

1. Make sure the booster battery is 12 volts and the negative terminal is grounded.
2. If the booster battery is in another vehicle, do not let the two vehicles touch.
3. Turn off all unnecessary lights and accessories.
4. Connect the jumper cables exactly in the sequence illustrated.

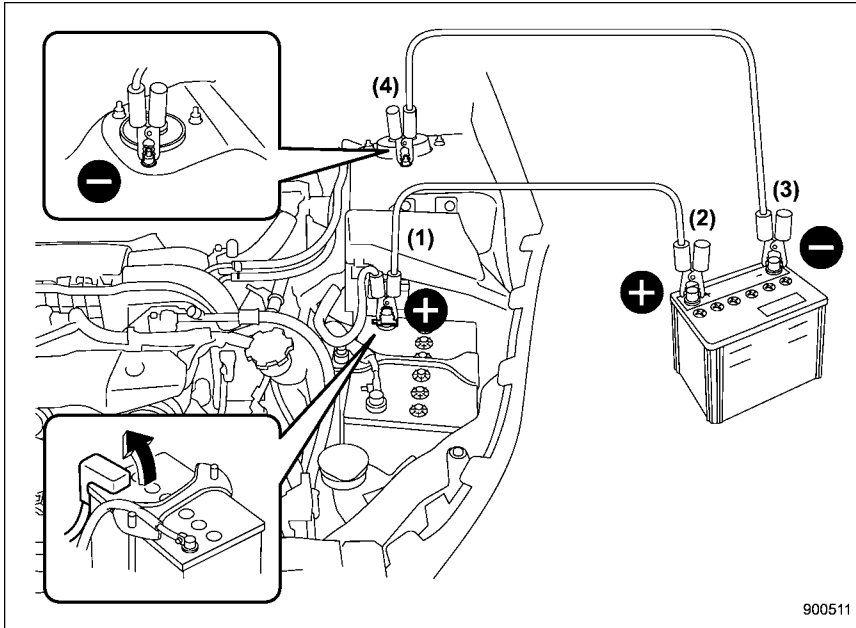

- 1) Connect one jumper cable to the positive (+) terminal on the discharged battery.
- 2) Connect the other end of the jumper cable to the positive (+) terminal of the booster battery.
- 3) Connect one end of the other cable to the negative (-) terminal of the booster battery.
- 4) Connect the other end of the cable to the strut mounting nut.

Make sure that the cables are not near any moving parts and that the cable clamps are not in contact with any other metal.

5. Start the engine of the vehicle with the booster battery and run it at moderate speed. Then start the engine of the vehicle that has the discharged battery.
6. When finished, carefully disconnect the cables in exactly the reverse order.

Engine overheating

WARNING

Never attempt to remove the radiator cap until the engine has been shut off and has fully cooled down. When the engine is hot, the coolant is under pressure. Removing the cap while the engine is still hot could release a spray of boiling hot coolant, which could burn you very seriously.

If the engine overheats, pull off the road safely and stop the vehicle in a safe place.

■ If steam is coming from the engine compartment

Turn off the engine and get everyone away from the vehicle until it cools down.

■ If no steam is coming from the engine compartment

For details about how to check the coolant level or how to add coolant, refer to “Engine coolant” ¶11-18.

1. Keep the engine running at idling speed.
2. Open the hood to ventilate the engine

compartment. Refer to “Engine hood” ¶11-7.

Confirm that the cooling fan is turning. If the fan is not turning, immediately turn off the engine and contact your authorized dealer for repair.

3. After the engine coolant temperature has dropped, turn off the engine.

If the coolant temperature high warning light illuminates, turn off the engine.

4. After the engine has fully cooled down, check the coolant level in the reserve tank.

If the coolant level is below the “MIN” mark, add coolant up to the “MAX” mark. Refer to “Engine coolant” ¶11-18 for details.

5. If there is no coolant in the reserve tank, add coolant to the reserve tank. Then remove the radiator cap and fill the radiator with coolant.

If you remove the radiator cap from a hot radiator, first wrap a thick cloth around the radiator cap, then turn the cap counterclockwise slowly without pressing down until it stops. Release the pressure from the radiator. After the pressure has been fully released, remove the cap by pressing down and turning it.

Towing

WARNING

Never tow AWD vehicles (including AT, MT and CVT) with the front wheels raised off the ground while the rear wheels are on the ground, or with the rear wheels raised off the ground while the front wheels are on the ground. This will cause the vehicle to spin away due to the operation or deterioration of the center differential.

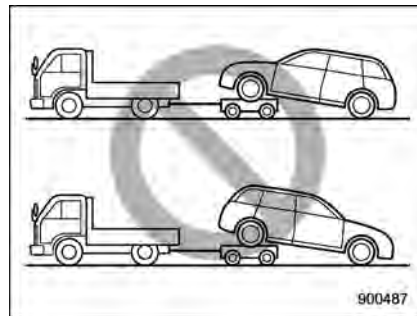

If towing is necessary, it is best done by your SUBARU dealer or a commercial towing service. Observe the following

procedures for safety.

■ Towing and tie-down hooks

The towing hooks should be used only in an emergency (e.g., to free a stuck vehicle from mud, sand or snow).

⚠ CAUTION

- Use only the specified towing hooks and tie-down hooks. Never use suspension parts or other parts of the body for towing or tie-down purposes.
- Never use the tie-down hook closest to the muffler under the vehicle for towing purposes.
- To prevent deformation to the bumper and the towing hook, do not apply excessive lateral load to the towing hooks.

Front towing hook:

1. Take out the towing hook and screwdriver from the on board tool bucket. Take out the jack handle from the trunk (Le-gacy) or cargo area (Outback).

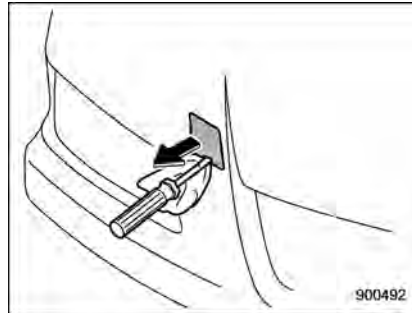

2. Pry off the cover on the front bumper using a screwdriver, and you will find a threaded hole for attaching the towing hook.

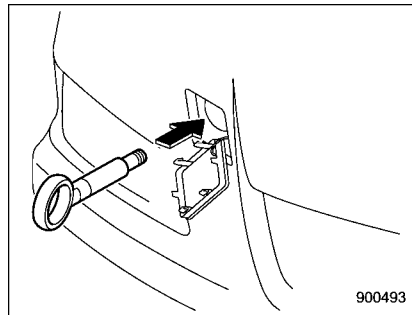

3. Screw the towing hook into the threaded hole until the threads can no

longer be seen.

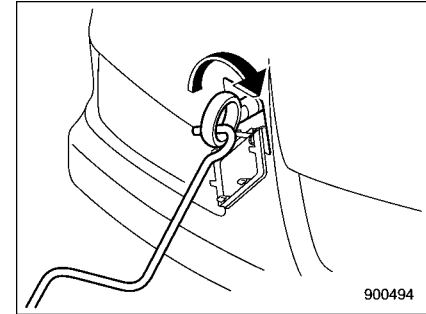

4. Tighten the towing hook securely using the jack handle.

After towing, remove the towing hook from the vehicle and stow it in the tool bucket. Fit the towing hook cover on the bumper.

⚠ WARNING

- Do not use the towing hook except when towing your vehicle.
- Be sure to remove the towing hook after towing. Leaving the towing hook mounted on the vehicle could interfere with proper operation of the SRS airbag system in a frontal collision.

Rear towing hook:

1. Take the towing hook out of the tool bucket and take the screwdriver out of the tool bucket. Take the jack handle out of the trunk (Legacy) or cargo area (Outback).

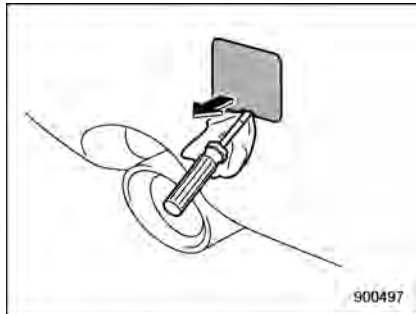

2. Pry off the cover on the rear bumper using a screwdriver, and you will find a threaded hole for attaching the towing hook.

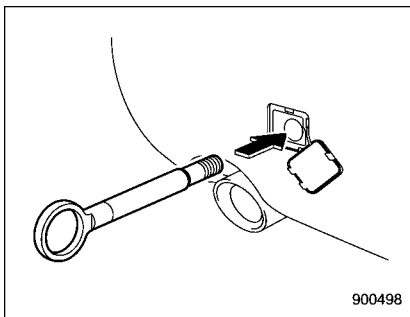

3. Screw the towing hook into the threaded hole until its thread can no longer be seen.

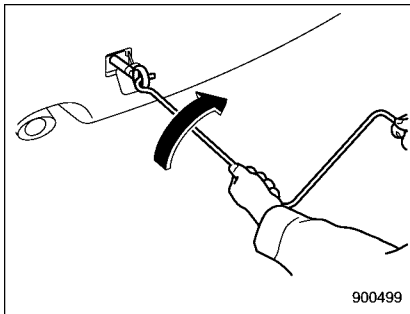

4. Tighten the towing hook securely using the jack handle.

After towing, remove the towing hook from the vehicle and stow it in the tool bucket. Fit the towing hook cover on the bumper.



WARNING

Do not use the towing hook except when towing your vehicle.

Front tie-down hooks:

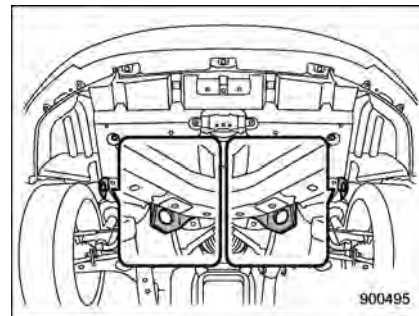

The front tie-down hooks are located between each of the front tires and the front bumper.

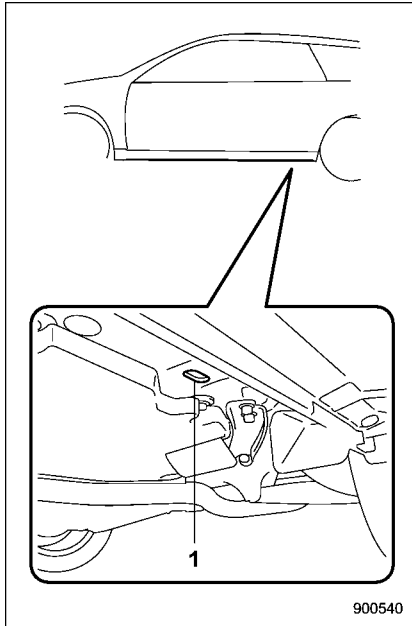
Rear tie-down holes:

1) Rear tie-down hole

The rear tie-down holes are located near each of the jack-up reinforcements.

 **WARNING**

Use the rear tie-down holes only for downward anchoring. If they are used to anchor the vehicle in any other direction, cables may slip out of the holes, possibly causing a dangerous situation.

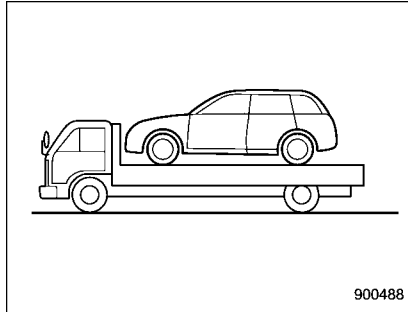
■ Using a flat-bed truck

This is the best way to transport your vehicle. Use the following procedures to ensure safe transportation.

1. Shift the select lever into the "P" position for AT and CVT models or the shift lever into "1st" for MT models.
2. Apply the parking brake firmly.
3. Secure the vehicle onto the carrier

properly with safety chains. Each safety chain should be equally tightened and care must be taken not to pull the chains so tightly that the suspension bottoms out.

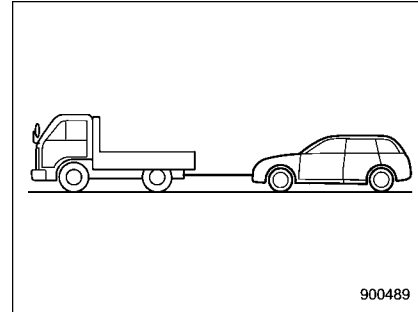
■ Towing with all wheels on the ground

 **WARNING**

- **Never turn the ignition switch to the "LOCK" position while the vehicle is being towed because the steering wheel and the direction of the wheels will be locked.**
- **Remember that the brake booster and power steering do not function when the engine is not running. Because the engine is**

turned off, it will take greater effort to operate the brake pedal and steering wheel.



CAUTION

- If transmission failure occurs, transport your vehicle on a flat-bed truck.
- Do not run the engine while being towed using this method. Transmission damage could result if the vehicle is towed with the engine running.
- For AT and CVT models, the traveling speed must be limited to less than 20 mph (30 km/h) and the traveling distance to less than 31 miles (50 km). For greater speeds and distances, transport your vehicle on a flat-bed truck.

1. Check the transmission and differential oil levels and add oil to bring it to the upper level if necessary.
2. Release the parking brake and put the transmission in neutral.
3. The ignition switch should be in the "Acc" position while the vehicle is being towed.
4. Take up slack in the towline slowly to

prevent damage to the vehicle.



WARNING

Electronic parking brake – if the electronic parking brake cannot be released

- When the electronic parking brake cannot be released, the electronic parking brake system may malfunction. Driving in such conditions may cause an unexpected accident. Contact your SUBARU dealer for inspection as soon as possible.
- You can release the electronic parking brake by using the electronic parking brake release tool in case of an emergency. However, after releasing the electronic parking brake by using the electronic parking brake release tool, contact your SUBARU dealer for inspection as soon as possible.
- Release the electronic parking brake by using the electronic parking brake release tool on a level road. Otherwise, the vehicle may move, which could cause an accident.

- **When releasing the electronic parking brake by using the electronic parking brake release tool, always perform the following items.**
 - Shift the shift lever in the “1” or “R” position (MT models).
 - Shift the select lever in the “P” position (AT and CVT models).
 - Use tire stops under the tires.
- **When releasing the electronic parking brake by using the electronic parking brake release tool, make sure that the ignition switch is in the “LOCK” position. Otherwise, the electronic parking brake system may operate and the electronic parking brake release tool may rotate and unexpected accident may occur.**

**CAUTION**

- **Under certain weather conditions (rain, snow, sandstorm, etc.), do not release the electronic parking brake by using the electronic parking brake release tool. If water or dust enters the device, the device may malfunction.**

- **If the cap cannot be removed, contact your SUBARU dealer for inspection.**
- **After releasing the electronic parking brake by using the electronic parking brake release tool, make sure that the cap is reinstalled to the parking brake release device. If the cap is not reinstalled, water or dust enters the device and the device may malfunction.**

NOTE

It may be difficult to release the electronic parking brake by using the electronic parking brake release tool. Have your SUBARU dealer release the electronic parking brake if necessary.

In the event that you cannot release the electronic parking brake by pulling the electronic parking brake switch or by depressing the accelerator pedal, you can release the electronic parking brake manually by using the electronic parking brake release tool.

1. Shift the shift lever in the “1” or “R” position (MT models) or the select lever in the “P” position (AT and CVT models).
2. Turn the ignition switch to the “LOCK” position.

3. Make sure that the brake system warning light and the indicator light on the parking brake switch have turned off.
4. Use tire stops under the tires to prevent the vehicle from moving.
5. Take out the electronic parking brake release tool. Refer to “Maintenance tools” 9-3.



6. Insert the electronic parking brake release tool into the cap of the parking brake release device.
7. Remove the cap of the parking brake release device by turning the electronic parking brake release tool counterclock-

wise.

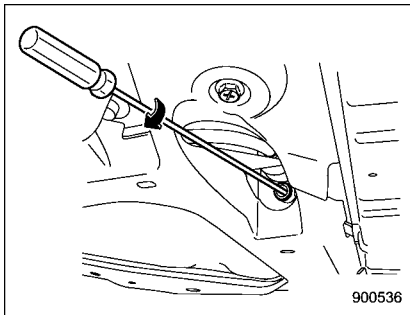

8. Break the white film and insert the electronic parking brake release tool into the parking brake release device.
9. Turn the electronic parking brake release tool clockwise approximately 200 to 250 rotations.
10. To confirm that the electronic parking brake is released, shift the shift lever or the select lever to the "N" position, slightly move the tire stops and have someone push the vehicle slightly while you remain in the driver's seat. If the vehicle moves, the electronic parking brake has been released.
11. Readjust the tire stops.
12. Reinstall the cap to the parking brake release device.

CAUTION

- Do not turn the electronic parking brake release tool counterclockwise or turn it around more than 300 times. Doing so may result in a malfunction of the electronic parking brake.
- Do not use electric power tools to turn the electronic parking brake release tool. Doing so may result in a malfunction of the electronic parking brake.

Trunk lid (Legacy) – if the trunk lid cannot be opened

The trunk lid can also be opened using the key.

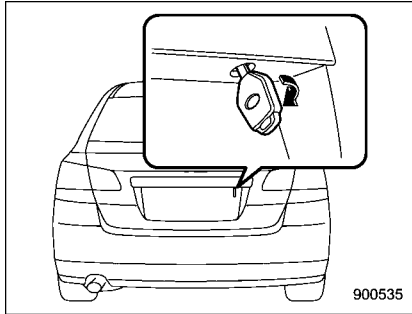

To open the trunk lid, insert the key into the key cylinder and turn it clockwise.

Rear gate (Outback) – if the rear gate cannot be unlocked

In the event that you cannot unlock the rear gate by operating the power door locking switches or the remote keyless entry system, you can unlock it from inside the cargo area.

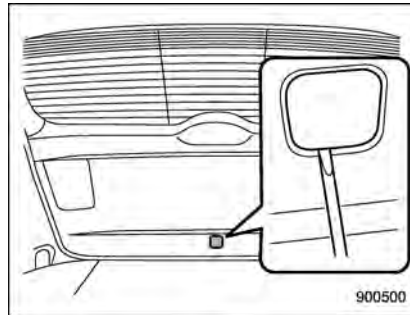

1. Remove the access cover at the bottom-center of the rear gate trim using flat-head screwdriver.
2. Locate the rear gate lock release lever behind the rear gate trim panel.

CAUTION

Never operate the rear gate lock release lever with your fingers because doing so may cause an injury.

Always use a flat-head screwdriver or a similar tool.



3. To unlock the rear gate, turn the lever to the right position using a flat-head screwdriver or a similar tool.
4. Open the rear gate from outside by raising the rear gate handle.

Moonroof – if moonroof cannot be closed

If the moonroof cannot be closed with the moonroof switch, you can close the moonroof manually.

1. Take out the screwdriver from the tool bucket.
2. Open the overhead console. Refer to "Overhead console" ¶6-8.

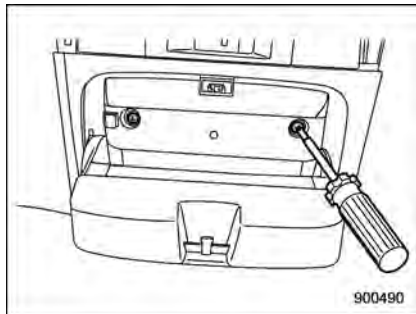

3. Remove the two screws that retain the moonroof switch body. Then, remove the moonroof switch.

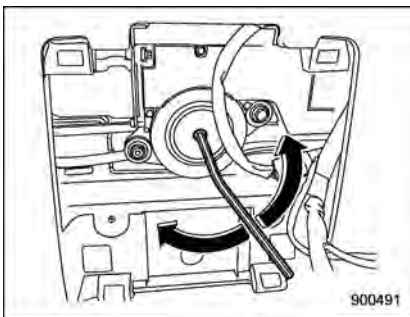

4. Insert the hex-head wrench in the end of the motor shaft.

To lower the moonroof, turn the wrench clockwise.

To close the moonroof, turn the wrench counterclockwise.

Have your vehicle checked and repaired by an authorized SUBARU dealer.

| | | | |
|---------------------------------------|-------------|---|-------------|
| Exterior care | 10-2 | Cleaning the interior | 10-5 |
| Washing..... | 10-2 | Seat fabric..... | 10-5 |
| Waxing and polishing..... | 10-3 | Leather seat materials..... | 10-5 |
| Cleaning aluminum wheels..... | 10-3 | Synthetic leather upholstery..... | 10-5 |
| Corrosion protection | 10-4 | Climate control panel, audio panel, instrument panel, console panel, switches, combination meter, and other plastic surface | 10-5 |
| Most common causes of corrosion | 10-4 | Navigation monitor (if equipped) | 10-6 |
| To help prevent corrosion..... | 10-4 | | |

Exterior care

■ Washing

CAUTION

- When washing the vehicle, the brakes may get wet. As a result, the brake stopping distance will be longer. To dry the brakes, drive the vehicle at a safe speed while lightly pressing the brake pedal to heat up the brakes.
- Do not wash the engine compartment and areas adjacent to it. If water enters the engine air intake, electrical parts or the power steering fluid reservoir, it will cause engine trouble or faulty power steering.
- Outback: Since your vehicle is equipped with a rear wiper, automatic car-wash brushes could become tangled around it, damaging the wiper arm and other components. Ask the automatic car-wash operator not to let the brushes touch the wiper arm or to fix the wiper arm on the rear window glass with adhesive tape before operating the machine.

NOTE

When having your vehicle washed in an automatic car wash, make sure beforehand that the car wash is of suitable type.

The best way to preserve your vehicle's beauty is frequent washing. Wash the vehicle at least once a month to avoid contamination by road grime.

Wash dirt off with a wet sponge and plenty of lukewarm or cold water. Do not wash the vehicle with hot water and in direct sunlight.

Salt, chemicals, insects, tar, soot, tree sap, and bird droppings should be washed off by using a light detergent, as required. If you use a light detergent, make certain that it is a neutral detergent. Do not use strong soap or chemical detergents. All cleaning agents should be promptly flushed from the surface and not allowed to dry there. Rinse the vehicle thoroughly with plenty of lukewarm water. Wipe the remaining water off with a chamois or soft cloth.

▼ Washing the underbody

Chemicals, salts and gravel used for deicing road surfaces are extremely corrosive, accelerating the corrosion of underbody components, such as the exhaust

system, fuel and brake lines, brake cables, floor pan and fenders, and suspension.

Thoroughly flush the underbody and inside of the fenders with lukewarm or cold water at frequent intervals to reduce the harmful effects of such agents.

Mud and sand adhering to the underbody components may accelerate their corrosion.

After driving off-road or on muddy or sandy roads, wash the mud and sand off the underbody.

Carefully flush the suspension and axle parts, as they are particularly prone to mud and sand buildup. Do not use a sharp-edged tool to remove caked mud.

CAUTION

- **Be careful not to damage brake hoses, sensor harnesses, and other parts when washing suspension components.**
- **Be careful not to flush the engine bottom for a long time. It may cause damage of some electrical parts.**

▼ Using a warm water washer

- Keep a good distance of 12 in (30 cm) or more between the washer nozzle and the vehicle.
- Do not wash the same area continuously.
- If a stain will not come out easily, wash by hand. Some warm water washers are of the high temperature, high pressure type, and they can damage or deform the resin parts such as mouldings, or cause water to leak into the vehicle.

■ Waxing and polishing

Always wash and dry the vehicle before waxing and polishing.

Use a good quality polish and wax and apply them according to the manufacturer's instructions. Wax or polish when the painted surface is cool.

Be sure to polish and wax the chrome trim, as well as the painted surfaces. Loss of wax on a painted surface leads to loss of the original luster and also quickens the deterioration of the surface. It is recommended that a coat of wax be applied at least once a month, or whenever the surface no longer repels water.

If the appearance of the paint has diminished to the point where the luster or tone cannot be restored, lightly polish the

surface with a fine-grained compound. Never polish just the affected area, but include the surrounding area as well. Always polish in only one direction. A No. 2000 grain compound is recommended. Never use a coarse-grained compound. Coarser grained compounds have a smaller grain-size number and could damage the paint. After polishing with a compound, coat with wax to restore the original luster. Frequent polishing with a compound or an incorrect polishing technique will result in removing the paint layer and exposing the undercoat. When in doubt, it is always best to contact your SUBARU dealer or an auto paint specialist.

NOTE

Be careful not to block the windshield washer nozzles with wax when waxing the vehicle.

■ Cleaning aluminum wheels

- Promptly wipe the aluminum wheels clean of any kind of grime or agent. If dirt is left on too long, it may be difficult to clean off.
- Do not use soap containing grit to clean the wheels. Be sure to use a neutral cleaning agent, and later rinse thoroughly with water. Do not clean the wheels with a stiff brush or expose them to a high-speed washing device.
- Clean the vehicle (including the aluminum wheels) with water as soon as possible when it has been splashed with sea water, exposed to sea breezes, or driven on roads treated with salt or other agents.

Corrosion protection

Your SUBARU has been designed and built to resist corrosion. Special materials and protective finishes have been used on most parts of the vehicle to help maintain fine appearance, strength, and reliable operation.

■ Most common causes of corrosion

The most common causes of corrosion are:

1. The accumulation of moisture retaining dirt and debris in body panel sections, cavities, and other areas.
2. Damage to paint and other protective coatings caused by gravel and stone chips or minor accidents.

Corrosion is accelerated on the vehicle when:

1. It is exposed to road salt or dust control chemicals, or used in coastal areas where there is more salt in the air, or in areas where there is considerable industrial pollution.
2. It is driven in areas of high humidity, especially when temperatures range just above freezing.
3. Dampness in certain parts of the vehicle remains for a long time, even

though other parts of the vehicle may be dry.

4. High temperatures will cause corrosion to parts of the vehicle which cannot dry quickly due to lack of proper ventilation.

■ To help prevent corrosion

Wash the vehicle regularly to prevent corrosion of the body and suspension components. Also, wash the vehicle promptly after driving on any of the following surfaces.

- roads that have been salted to prevent them from freezing in winter
- mud, sand, or gravel
- coastal roads

After the winter has ended, it is recommended that the underbody be given a very thorough washing.

Before the beginning of winter, check the condition of underbody components, such as the exhaust system, fuel and brake lines, brake cables, suspension, steering system, floor pan, and fenders. If any of them are found to be rusted, they should be given an appropriate rust prevention treatment or should be replaced. Contact your SUBARU dealer to perform this kind of maintenance and treatment if you need

assistance.

Repair chips and scratches in the paint as soon as you find them.

Check the interior of the vehicle for water and dirt accumulation under the floor mats because that could cause corrosion. Occasionally check under the mats to make sure the area is dry.

Keep your garage dry. Do not park your vehicle in a damp, poorly ventilated garage. In such a garage, corrosion can be caused by dampness. If you wash the vehicle in the garage or put the vehicle into the garage when wet or covered with snow, that can cause dampness.

If your vehicle is operated in cold weather and/or in areas where road salts and other corrosive materials are used, the door hinges and locks, trunk lid lock, and hood latch should be inspected and lubricated periodically.

Cleaning the interior

Use a soft, damp cloth to clean the climate control panel, audio equipment, instrument panel, center console, combination meter panel, and switches. (Do not use organic solvents.)

■ Seat fabric

Remove loose dirt, dust or debris with a vacuum cleaner. If the dirt is caked on the fabric or hard to remove with a vacuum cleaner, use a soft brush then vacuum it. Wipe the fabric surface with a tightly wrung cloth and dry the seat fabric thoroughly. If the fabric is still dirty, wipe using a solution of mild soap and luke-warm water then dry thoroughly.

If the stain does not come out, try a commercially-available fabric cleaner. Use the cleaner on a hidden place and make sure it does not affect the fabric adversely. Use the cleaner according to its instructions.

NOTE

When cleaning the seat, do not use benzine, paint thinner, or any similar materials.

■ Leather seat materials

The leather used by SUBARU is a high quality natural product which will retain its distinctive appearance and feel for many years with proper care.

Allowing dust or road dirt to build up on the surface can cause the material to become brittle and to wear prematurely. Regular cleaning with a soft, moist, natural fiber cloth should be performed monthly, taking care not to soak the leather or allow water to penetrate the stitched seams.

A mild detergent suitable for cleaning woolen fabrics may be used to remove difficult dirt spots, rubbing with a soft, dry cloth afterwards to restore the luster. If your SUBARU is to be parked for a long time in bright sunlight, it is recommended that the seats and headrests be covered, or the windows shaded, to prevent fading or shrinkage.

Minor surface blemishes or bald patches may be treated with a commercial leather spray lacquer. You will discover that each leather seat section will develop soft folds or wrinkles, which is characteristic of genuine leather.

■ Synthetic leather upholstery

The synthetic leather material used on the SUBARU may be cleaned using mild soap

or detergent and water, after first vacuuming or brushing away loose dirt. Allow the soap to soak in for a few minutes and wipe off with a clean, damp cloth. Commercial foam-type cleaners suitable for synthetic leather materials may be used when necessary.

NOTE

Strong cleaning agents such as solvents, paint thinners, window cleaner or gasoline must never be used on leather or synthetic interior materials.

■ Climate control panel, audio panel, instrument panel, console panel, switches, combination meter, and other plastic surface

Use a soft, damp cloth to clean the climate control panel, audio equipment, instrument panel, center console, combination meter panel, and switches.

NOTE

Do not use organic solvents such as paint thinners or gasoline, or strong cleaning agents that contain those solvents.

■ **Navigation monitor (if equipped)**

To clean the navigation monitor, wipe it with a silicone cloth or with a soft cloth. If the navigation monitor is extremely dirty, clean it with a soft cloth moistened with neutral detergent then carefully wipe off any remaining detergent.

NOTE

- **Do not spray neutral detergent directly onto the monitor. Doing so could damage the monitor's components.**
- **Do not wipe the monitor with a hard cloth. Doing so could scratch the monitor.**
- **Do not use cleaning fluid that contains thinner, gasoline, or any other volatile substance. Such cleaning fluid could erase the lettering on the switches at the bottom of the monitor.**

| | | | |
|---|-------|--|-------|
| Maintenance schedule | 11-3 | Drive belts | 11-23 |
| Maintenance precautions | 11-3 | Manual transmission oil | 11-23 |
| Before checking or servicing in the engine compartment..... | 11-4 | Checking the oil level | 11-23 |
| When checking or servicing in the engine compartment (2.5 L non-turbo models) | 11-4 | Recommended grade and viscosity | 11-24 |
| When checking or servicing in the engine compartment while the engine is running..... | 11-5 | Automatic transmission fluid | 11-24 |
| Maintenance tips | 11-5 | Checking the fluid level..... | 11-24 |
| Removing and reinstalling clips | 11-5 | Recommended fluid..... | 11-25 |
| Removing air intake duct..... | 11-7 | Continuously variable transmission fluid | 11-26 |
| Pulling off the fender lining | 11-7 | Front differential gear oil (AT and CVT models) | 11-26 |
| Engine hood | 11-7 | Checking the oil level | 11-26 |
| Engine compartment overview | 11-9 | Recommended grade and viscosity | 11-27 |
| 2.5 L non-turbo models | 11-9 | Rear differential gear oil | 11-27 |
| 2.5 L turbo models | 11-10 | Checking the gear oil level..... | 11-27 |
| 3.6 L models | 11-11 | Recommended grade and viscosity | 11-28 |
| Engine oil | 11-12 | Power steering fluid | 11-29 |
| Checking the oil level..... | 11-12 | Checking the fluid level..... | 11-29 |
| Changing the oil and oil filter..... | 11-14 | Recommended fluid..... | 11-30 |
| Recommended grade and viscosity | 11-16 | Brake fluid | 11-30 |
| Recommended grade and viscosity under severe driving conditions | 11-17 | Checking the fluid level..... | 11-30 |
| Cooling system | 11-17 | Recommended brake fluid | 11-31 |
| Cooling fan, hose and connections..... | 11-17 | Clutch fluid (MT models) | 11-31 |
| Engine coolant..... | 11-18 | Checking the fluid level..... | 11-31 |
| Air cleaner element | 11-20 | Recommended clutch fluid..... | 11-32 |
| Replacing the air cleaner element | 11-21 | Brake booster | 11-32 |
| Spark plugs | 11-22 | Brake pedal | 11-33 |
| Recommended spark plugs | 11-22 | Checking the brake pedal free play | 11-33 |
| | | Checking the brake pedal reserve distance..... | 11-33 |

| | |
|--|-------|
| Clutch pedal (MT models)..... | 11-33 |
| Checking the clutch function | 11-33 |
| Checking the clutch pedal free play | 11-34 |
| Replacement of brake pad and lining..... | 11-34 |
| Breaking-in of new brake pads and linings..... | 11-34 |
| Tires and wheels | 11-35 |
| Types of tires | 11-35 |
| Tire pressure monitoring system (TPMS) (if equipped)..... | 11-35 |
| Tire inspection | 11-37 |
| Tire pressures and wear | 11-37 |
| Wheel balance..... | 11-39 |
| Wear indicators | 11-39 |
| Tire rotation direction mark | 11-40 |
| Tire rotation | 11-40 |
| Tire replacement | 11-41 |
| Wheel replacement..... | 11-41 |
| Aluminum wheels..... | 11-42 |
| Windshield washer fluid | 11-42 |
| Replacement of wiper blades | 11-43 |
| Windshield wiper blade assembly | 11-44 |
| Windshield wiper blade rubber | 11-44 |

| | |
|---|-------|
| Rear window wiper blade assembly (Outback) | 11-45 |
| Rear window wiper blade rubber (Outback) | 11-46 |
| Battery | 11-47 |
| Fuses | 11-48 |
| Main fuse..... | 11-50 |
| Installation of accessories | 11-50 |
| Replacing bulbs | 11-50 |
| Headlight..... | 11-50 |
| Front turn signal light | 11-53 |
| Front position light | 11-53 |
| Front fog light (if equipped)..... | 11-53 |
| Rear combination lights | 11-54 |
| Tail/Back-up light (Outback) | 11-56 |
| License plate light | 11-57 |
| Dome light..... | 11-58 |
| Map light | 11-59 |
| Vanity mirror light..... | 11-59 |
| Door step light..... | 11-60 |
| Cargo area light (Outback) | 11-60 |
| Trunk light (Legacy)..... | 11-60 |
| Other bulbs | 11-60 |

Maintenance schedule

The scheduled maintenance items required to be serviced at regular intervals are shown in the "Warranty and Maintenance Booklet".

For details about your maintenance schedule, read the separate "Warranty and Maintenance Booklet".

Maintenance precautions

When maintenance and service are required, it is recommended that all work be done by an authorized SUBARU dealer.

If you perform maintenance and service by yourself, you should familiarize yourself with the information provided in this section on general maintenance and service for your SUBARU.

Incorrect or incomplete service could cause improper or unsafe vehicle operation. Any problems caused by improper maintenance and service performed by you are not eligible for warranty coverage.



WARNING

- Testing of an All-Wheel Drive vehicle must NEVER be performed on a single two-wheel dynamometer or similar apparatus. Attempting to do so will result in transmission damage and in uncontrolled vehicle movement and may cause an accident or injuries to persons nearby.
- Always select a safe area when performing maintenance on your vehicle.

- Always be very careful to avoid injury when working on the vehicle. Remember that some of the materials in the vehicle may be hazardous if improperly used or handled, for example, battery acid.
- Your vehicle should only be serviced by persons fully competent to do so. Serious personal injury may result to persons not experienced in servicing vehicles.
- Always use the proper tools and make certain that they are well maintained.
- Never get under the vehicle supported only by a jack. Always use safety stands to support the vehicle.
- Never keep the engine running in a poorly ventilated area, such as a garage or other closed areas.
- Do not smoke or allow open flames around the fuel or battery. This will cause a fire.
- Because the fuel system is under pressure, replacement of the fuel filter should be performed only by your SUBARU dealer.
- Wear adequate eye protection to

guard against getting oil or fluids in your eyes. If something does get in your eyes, thoroughly wash them out with clean water.

- Do not tamper with the wiring of the SRS airbag system or seatbelt pretensioner system, or attempt to take its connectors apart, as that may activate the system or it can render it inoperative. NEVER use a circuit tester for these wiring. If your SRS airbag or seatbelt pretensioner needs service, consult your nearest SUBARU dealer.

■ Before checking or servicing in the engine compartment

 **WARNING**

- Always stop the engine and set the parking brake firmly to prevent the vehicle from moving.
- Always let the engine cool down. Engine parts become very hot when the engine is running and remain hot for some time after the engine is stopped.
- Do not spill engine oil, engine coolant, brake fluid or any other fluid on hot engine components. This may cause a fire.
- Always remove the key from the ignition switch. When the ignition switch is in the "ON" position, the cooling fan may operate suddenly even when the engine is stopped.
- Before performing any servicing on a vehicle equipped with a remote engine start system temporarily place that system in the service mode to prevent it from unexpectedly starting the engine.

■ When checking or servicing in the engine compartment (2.5 L non-turbo models)

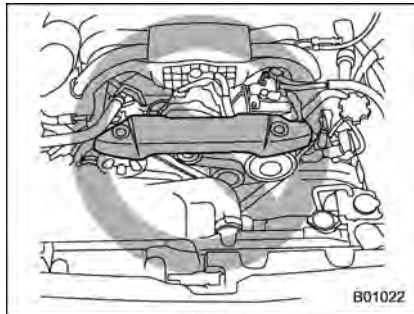

 **CAUTION**

Do not contact the belt cover while checking the components in the engine compartment. Doing so may cause your hand to slip off the belt cover and result in an unexpected injury.

■ **When checking or servicing in the engine compartment while the engine is running**

WARNING

A running engine can be dangerous. Keep your fingers, hands, clothing, hair and tools away from the cooling fan, belts and any other moving engine parts. Removing rings, watches and ties is advisable.

Maintenance tips

Some clips and fender linings must be removed before replacing the air cleaner elements or specific bulbs.

■ Removing and reinstalling clips

▼ Removing clips

There are several types of clips used for your vehicle.

▽ Type A clips

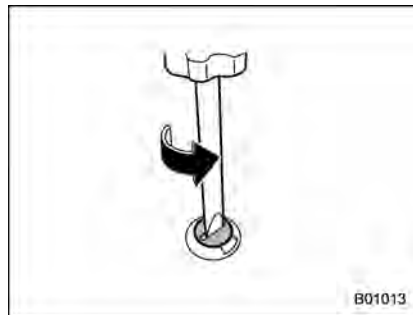

1. Turn the clips counterclockwise using a flat-head screwdriver until the center portion of the clip is raised.

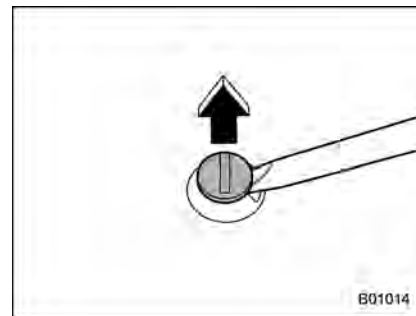

2. Remove the clips with a flat-head screwdriver using leverage.

▽ Type B clips

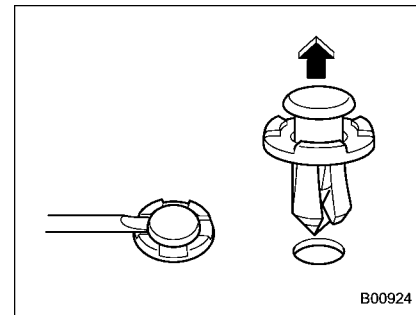

1. Pull out the center portion of the clip using a flat-head screwdriver as shown in

– CONTINUED –

the illustration.

2. Pull the protruded center portion to remove the entire body of the clip.

▽ **Type C clips**

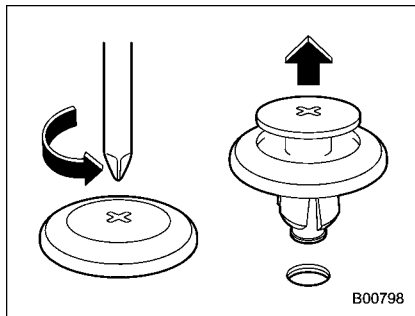

1. Turn the clip counterclockwise using a Phillips screwdriver until the center portion of the clip is raised.
2. Remove the entire clip by pulling it up.

▼ **Reinstalling clips**

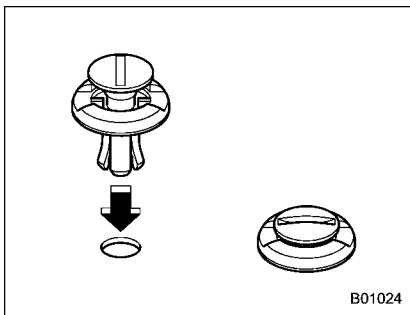

Type A clips

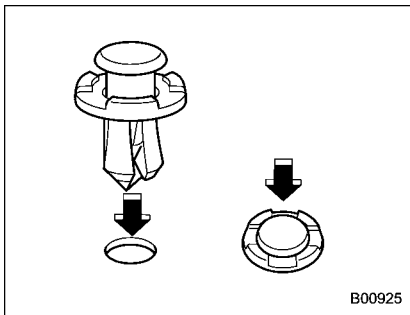

Type B clips

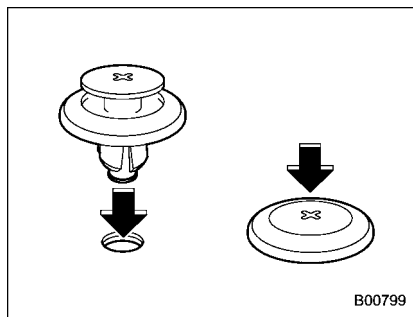

Type C clips

Insert the clip without the center portion first and then push the center portion of the clip into the hole.

■ Removing air intake duct

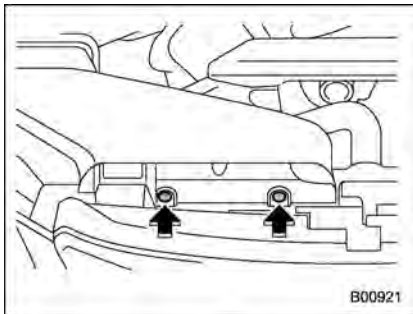

Use a screwdriver to undo the clips on the air intake duct, then remove the air intake duct. Refer to "Type A clips" ¶ 11-5.

■ Pulling off the fender lining

It is necessary to pull off the fender lining when replacing some bulbs.

1. Start the engine and turn the steering wheel fully in the opposite direction of the bulb to be replaced.
2. Stop the engine.

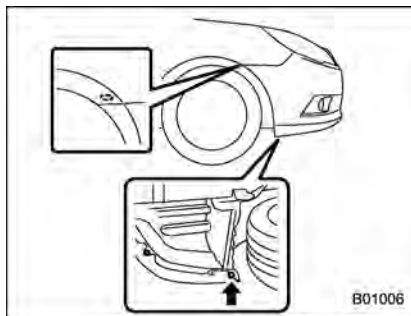

3. Remove the clip from the fender lining. Refer to "Type B clips" ¶ 11-5.

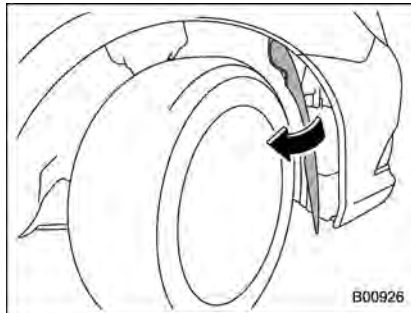

4. Pull off the fender lining.

Engine hood

To open the hood:

1. If the wiper blades are lifted off the windshield, return them to their original positions.

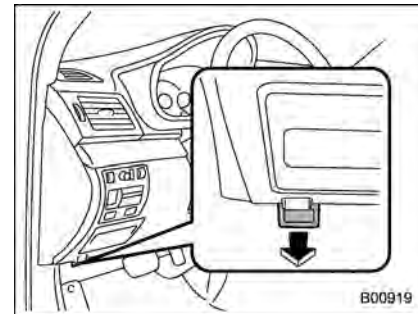

2. Pull the hood release knob under the instrument panel.

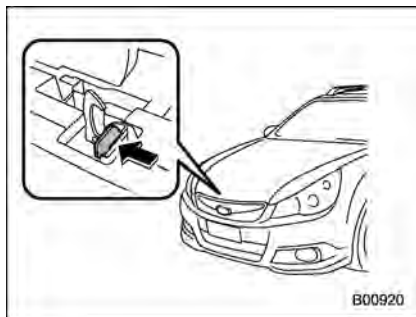

3. Release the secondary hood release by moving the lever between the front grille and the hood toward the left.
4. Lift up the hood.

To close the hood:

1. Lower the hood to a height of approximately 5.9 in (15 cm) above its closed position and then let it drop.
2. After closing the hood, be sure the hood is securely locked.

If this does not close the hood, release it from a slightly higher position. Do not push the hood forcibly to close it. It could deform the metal.

⚠ WARNING

Always check that the hood is properly locked before you start driving. If it is not, it might fly open while the vehicle is moving and block your view, which may cause an accident and serious bodily injury.

Engine compartment overview

■ 2.5 L non-turbo models

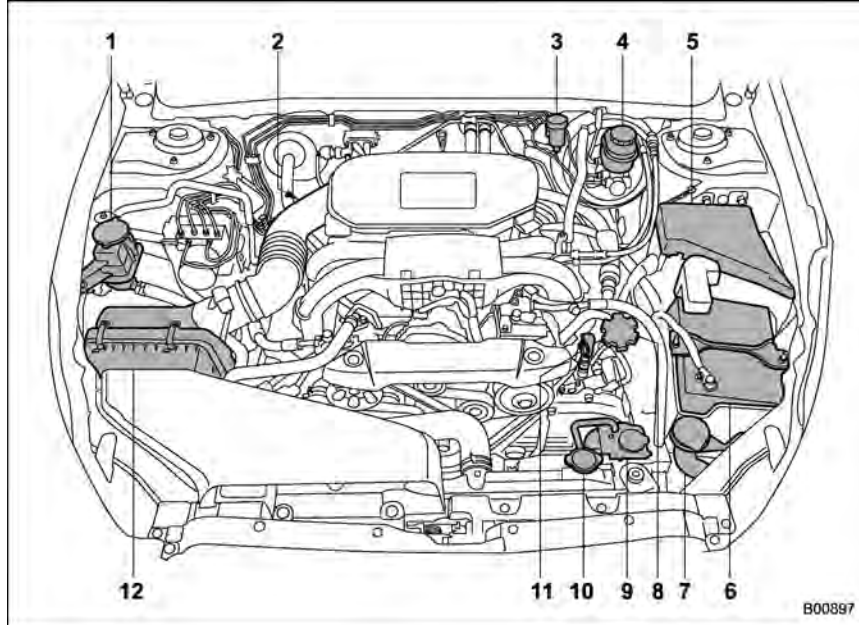

- 1) Power steering fluid reservoir (page 11-29)
- 2) Manual transmission oil level gauge (MT) (page 11-23)
- 3) Clutch fluid reservoir (page 11-31)
- 4) Brake fluid reservoir (page 11-30)
- 5) Fuse box (page 11-48)
- 6) Battery (page 11-47)
- 7) Windshield washer tank (page 11-42)
- 8) Engine oil filler cap (page 11-12)
- 9) Engine coolant reservoir (page 11-18)
- 10) Radiator cap (page 11-18)
- 11) Engine oil level gauge (page 11-12)
- 12) Air cleaner case (page 11-20)

B00897

■ 2.5 L turbo models

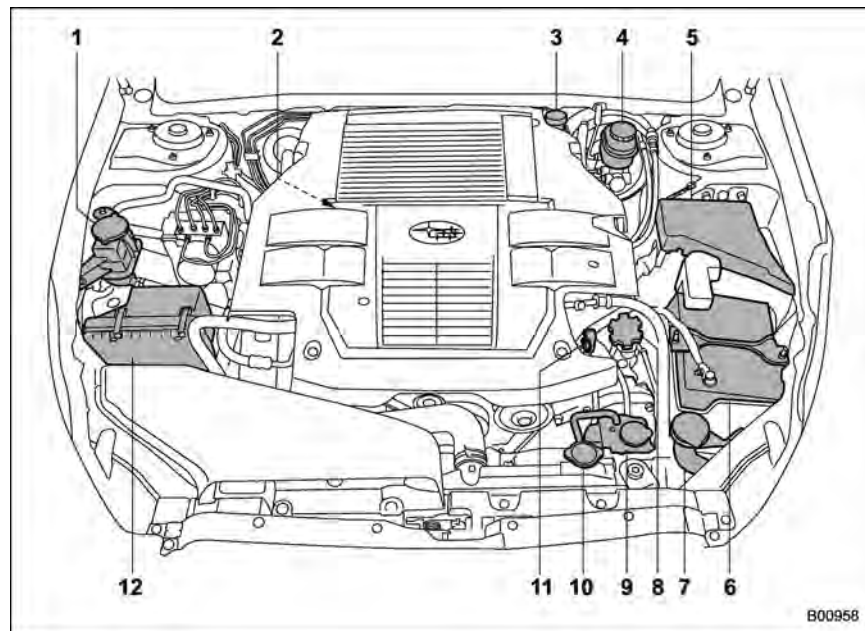

- 1) Power steering fluid reservoir (page 11-29)
- 2) Manual transmission oil level gauge (MT) (page 11-23)
- 3) Clutch fluid reservoir (page 11-31)
- 4) Brake fluid reservoir (page 11-30)
- 5) Fuse box (page 11-48)
- 6) Battery (page 11-47)
- 7) Windshield washer tank (page 11-42)
- 8) Engine oil filler cap (page 11-12)
- 9) Engine coolant reservoir (page 11-18)
- 10) Radiator cap (page 11-18)
- 11) Engine oil level gauge (page 11-12)
- 12) Air cleaner case (page 11-20)

B00958

■ **3.6 L models**

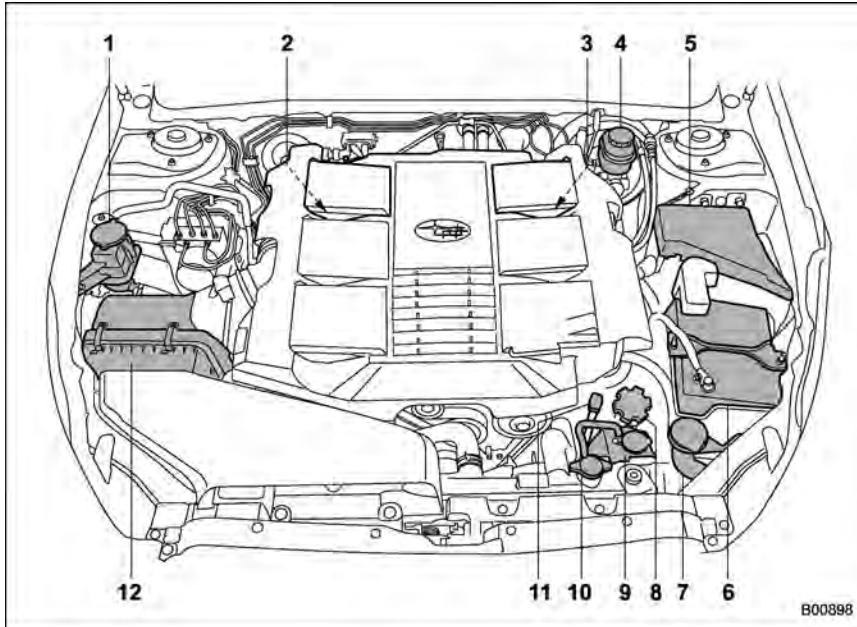

- 1) Power steering fluid reservoir (page 11-29)
- 2) Differential gear oil level gauge (AT) (page 11-26)
- 3) Automatic transmission fluid level gauge (page 11-24)
- 4) Brake fluid reservoir (page 11-30)
- 5) Fuse box (page 11-48)
- 6) Battery (page 11-47)
- 7) Windshield washer tank (page 11-42)
- 8) Engine oil filler cap (page 11-12)
- 9) Engine coolant reservoir (page 11-18)
- 10) Radiator cap (page 11-18)
- 11) Engine oil level gauge (page 11-12)
- 12) Air cleaner case (page 11-20)

B00898

Engine oil

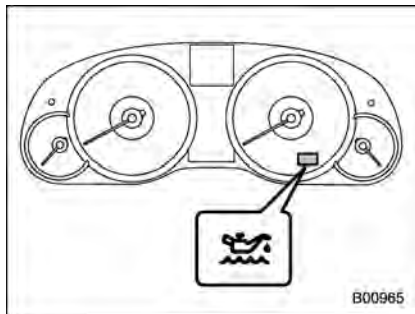

NOTE

- When the engine low oil level warning light illuminates, have your vehicle inspected by your SUBARU dealer as soon as possible.
- The engine oil consumption rate is not stabilized, and therefore cannot be determined until the vehicle has traveled at least several thousand miles (kilometers). Even after break-in, when the vehicle is used under severe driving conditions such as those mentioned in the Warranty and Maintenance Booklet, engine oil is consumed or deteriorated more quickly than under normal driving conditions. If you drive your vehicle under these severe

conditions, you should check the oil level at least at every second fuel fill-up time, and change the oil more frequently. Please refer to the Warranty and Maintenance Booklet for more details.

- If the oil consumption rate seems abnormally high after the break-in period, for example more than 1 quart per 1,200 miles or 1 liter per 2,000 kilometers, we recommend that you contact your SUBARU dealer.

■ Checking the oil level

Check the engine oil level at each fuel stop.

1. Park the vehicle on a level surface and stop the engine. If you check the oil level just after stopping the engine, wait a few minutes for the oil to drain back into the oil pan before checking the level.

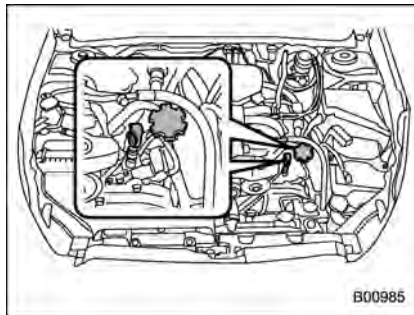

2. Pull out the level gauge, wipe it clean, and insert it again.
3. Be sure the level gauge is correctly inserted until it stops with the graphic symbol “” on its top appearing as shown in the illustration.

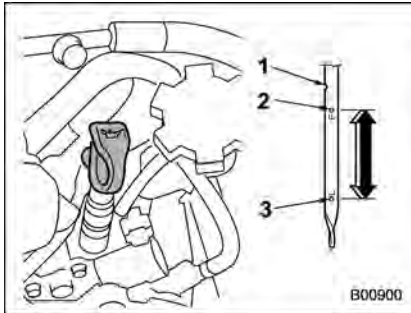
**2.5 L models**

- 1) Notch
- 2) Full level
- 3) Low level

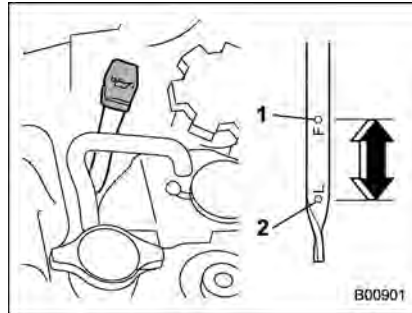
**3.6 L models**

- 1) Full level
- 2) Low level

4. Pull out the level gauge again and check the oil level on it. If it is below the lower level, add oil to bring the level up to the upper level.

⚠ CAUTION

- Use only engine oil with the recommended grade and viscosity.

- Be careful not to spill engine oil when adding it. If oil touches the exhaust pipe, it may cause a bad smell, smoke, and/or a fire. If engine oil gets on the exhaust pipe, be sure to wipe it off.

NOTE

- To prevent overfilling the engine oil, do not add any additional oil above the upper level when the engine is cold.
- In 2.5 L engine models, the level gauge has a notch above the upper level. Just after driving or while the engine is warm, the engine oil level reading may be in a range between the upper level and the notch mark. This is caused by thermal expansion of the engine oil.

■ Changing the oil and oil filter

Change the oil and oil filter according to the maintenance schedule in the “Warranty and Maintenance Booklet”.

The engine oil and oil filter must be changed more frequently than listed in the maintenance schedule when driving on dusty roads, when short trips are frequently made, or when driving in extremely cold weather.

1. Warm up the engine by letting the engine idle for approximately 10 minutes to ease draining the engine oil.
2. Park the vehicle on a level surface and stop the engine.
3. Remove the oil filler cap.

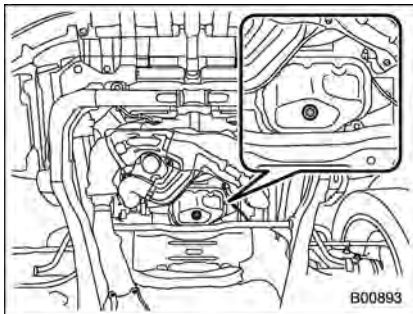

2.5 L non-turbo models

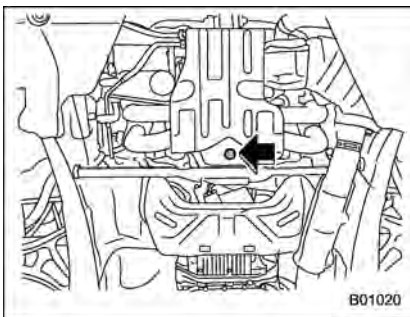

2.5 L turbo models

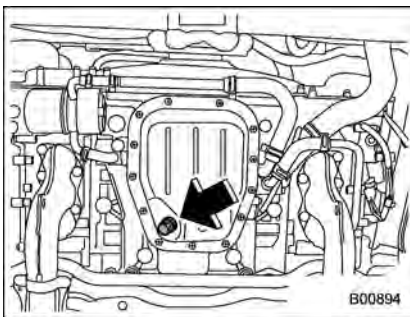

3.6 L models

4. Drain out the engine oil by removing the drain plug while the engine is still warm. The used oil should be drained into an appropriate container and disposed of

properly.



WARNING

Be careful not to burn yourself with hot engine oil.

5. Wipe the seating surface and around the drain plug with a clean cloth and tighten it securely with a new sealing washer after the oil has completely drained out.

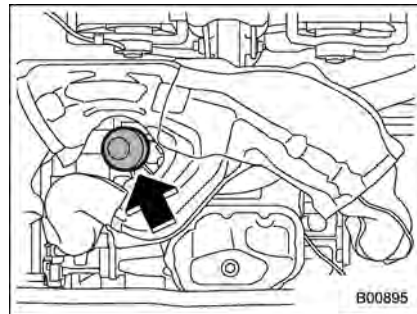

2.5 L non-turbo models

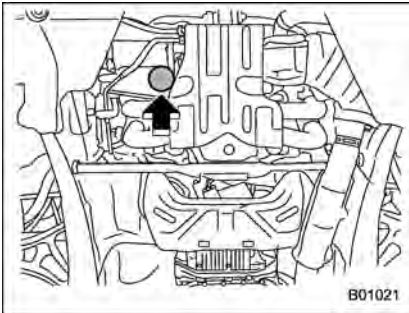
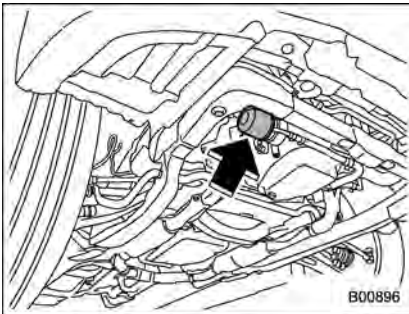
**2.5 L turbo models****3.6 L models**

6. Remove the oil filter with an oil filter wrench.
7. Before installing a new oil filter, apply a thin coat of engine oil to the seal.

8. Clean the rubber seal seating area of the bottom of engine and install the oil filter by hand turning. Be careful not to twist or damage the seal.

9. Tighten the oil filter by the amount indicated in the following table after the seal makes contact with the bottom of engine.

| Model | Oil filter color | Part number | Amount of rotation |
|--------------|------------------|-------------|--------------------|
| 2.5 L models | Black | 15208AA100 | 1 rotation |
| | Blue | 15208AA12A | 7/8 rotation |
| 3.6 L models | Black | 15208AA031 | 3/4 rotation |

CAUTION

- **Never over tighten the oil filter because that can result in an oil leak.**
- **Thoroughly wipe off any engine oil that has spilled over the exhaust pipe and/or under-cover. If left unremoved, the oil could catch fire.**

10. Reinstall the cover under the oil filter.
11. Pour engine oil through the filler neck.

Oil capacity (guideline):

- 2.5 L models: 4.2 US qt (4.0 liters, 3.5 Imp qt)**
- 3.6 L models: 6.7 US qt (6.3 liters, 5.5 Imp qt)**

The oil quantity indicated above is only a guideline. The necessary quantity of oil depends on the quantity of oil that has been drained. The quantity of drained oil differs slightly depending on the temperature of the oil and the time the oil is left flowing out. After refilling the engine with oil, therefore, you must use the level gauge to confirm that the level is correct.

12. Start the engine and make sure that no oil leaks appear around the filter's rubber seal and drain plug.

13. Keep the engine idling until the engine reaches the normal operating temperature range, as indicated by the temperature gauge on the combination meter. After that, check the engine oil level again. For further details about the check procedure, refer to "Checking the oil level" 11-12.

■ Recommended grade and viscosity



Use only engine oil with the recommended grade and viscosity.

Oil grade:

- ILSAC GF-4, which can be identified with the ILSAC certification mark (Starburst mark)
- or API classification SM with the words "ENERGY CONSERVING"

These recommended oil grades can be identified by looking for either or both of the following marks displayed on the oil container.

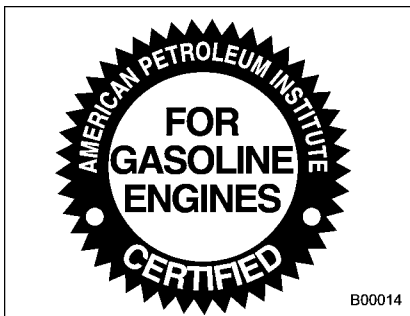

ILSAC Certification Mark (Starburst Mark)

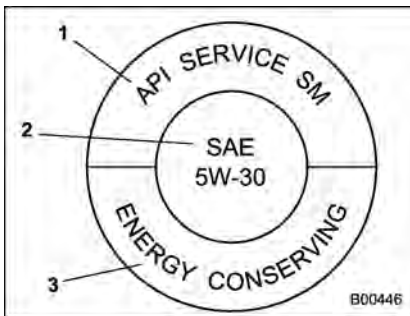

API Service label

- 1) Indicates the oil quality by API designations
- 2) Indicates the SAE oil viscosity grade
- 3) Indicates that the oil has fuel saving capabilities

In choosing an oil, you want the proper quality and viscosity, as well as one that will add to fuel economy. The following table lists the recommended viscosities and applicable temperatures.

When adding oil, different brands may be used together as long as they are the same API classification and SAE viscosity as those recommended by SUBARU.

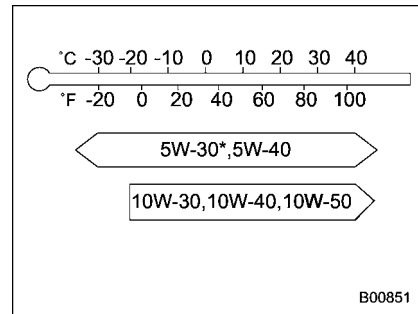

SAE viscosity number and applicable temperature

*: 5W-30 is preferred.

Engine oil viscosity (thickness) affects fuel economy. Oils of lower viscosity provide better fuel economy. However, in hot weather, oil of higher viscosity is required to properly lubricate the engine.

■ Recommended grade and viscosity under severe driving conditions

If the vehicle is used in desert areas, in areas with very high temperatures, or used for heavy-duty applications such as towing a trailer, use of oil with the following grade and viscosities is recommended.

API classification SM or SL:

SAE viscosity No.:

30, 40, 10W-50, 20W-40, 20W-50

Cooling system



WARNING

Never attempt to remove the radiator cap until the engine has been shut off and has cooled down completely. Since the coolant is under pressure, you may suffer serious burns from a spray of boiling hot coolant when the cap is removed.



CAUTION

- Vehicles are filled at the factory with SUBARU Super Coolant that does not require the first change for 11 years/137,500 miles (11 years/220,000 km). This coolant should not be mixed with any other brand or type of coolant during this period. Mixing with a different coolant will reduce the life of the coolant. Should it be necessary to top off the coolant for any reason, use only SUBARU Super Coolant.

If the SUBARU Super Coolant is diluted with another brand or type, the maintenance interval is

shortened to that of the mixing coolant.

- Do not splash the engine coolant over painted parts. The alcohol contained in the engine coolant may damage the paint surface.

■ Cooling fan, hose and connections

Your vehicle employs an electric cooling fan which is thermostatically controlled to operate when the engine coolant reaches a specific temperature.

If the radiator cooling fan does not operate even when the coolant temperature high warning light illuminates, the cooling fan circuit may be defective. Check the fuse and replace it if necessary. Refer to "Fuses" ¶11-48 and "Fuses and circuits" ¶12-6. If the fuse is not blown, have the cooling system checked by your SUBARU dealer.

If frequent addition of coolant is necessary, there may be a leak in the engine cooling system. It is recommended that the cooling system and connections be checked for leaks, damage, or looseness.

■ Engine coolant

▼ Checking the coolant level

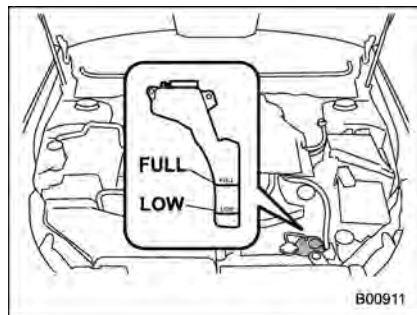

Check the coolant level at each fuel stop.

1. Check the coolant level on the outside of the reservoir while the engine is cool.
2. If the level is close to or lower than the "LOW" level mark, add coolant up to the "FULL" level mark. If the reserve tank is empty, remove the radiator cap and refill as required.

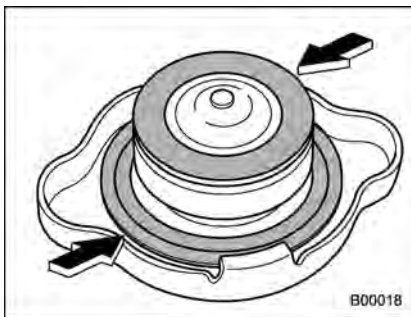

3. After refilling the reserve tank and the radiator, reinstall the caps and check that the rubber gaskets inside the radiator cap are in the proper position.

▲ CAUTION

- **Be careful not to spill engine coolant when adding it. If coolant touches the exhaust pipe, it may cause a bad smell, smoke, and/or a fire. If engine coolant gets on the exhaust pipe, be sure to wipe it off.**
- **Do not splash the engine coolant over painted parts. The alcohol contained in the engine coolant may damage the paint surface.**

▼ Changing the coolant

▲ WARNING

Never attempt to remove the radiator cap until the engine has been shut off and has cooled down completely. Since the coolant is under pressure, you may suffer serious burns from a spray of boiling hot coolant when the cap is removed.

Always add genuine SUBARU cooling system conditioner whenever the coolant is replaced.

Change the engine coolant and add genuine SUBARU cooling system conditioner using the following procedures according to the maintenance schedule in the "Warranty and Maintenance Booklet".

1. Remove the under cover.

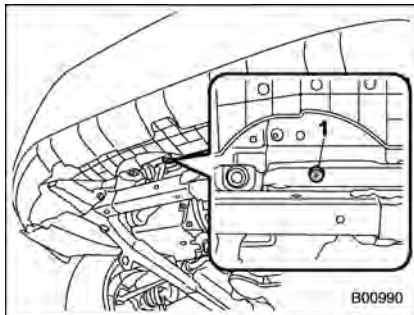

2.5 L models

- 1) Drain plug

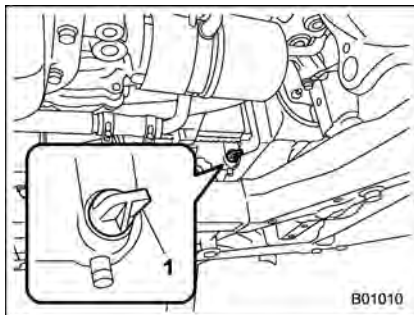

3.6 L models

- 1) Drain plug

2. Place a proper container under the

drain plug and loosen the drain plug.

3. Loosen the radiator cap to drain the coolant from the radiator. Then drain the coolant from the reserve tank. Tighten the drain plug securely.

4. Install the under cover.

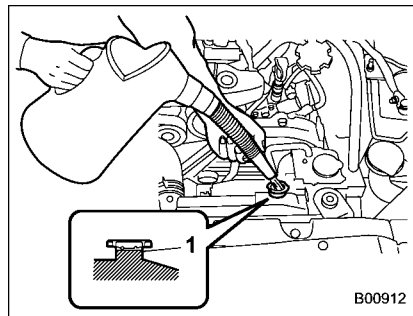

- 1) Fill up to here

5. Slowly pour the coolant and fill up to just below the filler neck, allowing enough room to add genuine SUBARU cooling system conditioner in the radiator. Add genuine SUBARU cooling system conditioner until the coolant level reaches the filler neck. Do not pour the coolant too quickly, as this may lead to insufficient air bleeding and trapped air in the system.

Coolant capacity (guideline):

2.5 L non-turbo models:

MT: 6.9 US qt (6.5 liters, 5.7 Imp qt)

CVT: 6.8 US qt (6.4 liters, 5.6 Imp qt)

2.5 L turbo models:

6.9 US qt (6.5 liters, 5.7 Imp qt)

3.6 L models:

6.9 US qt (6.5 liters, 5.7 Imp qt)



CAUTION

- Be careful not to spill engine coolant when adding it. If coolant touches the exhaust pipe, it may cause a bad smell, smoke, and/or a fire. If engine coolant gets on the exhaust pipe, be sure to wipe it off.
- Do not splash the engine coolant over painted parts. The alcohol contained in the engine coolant may damage the paint surface.

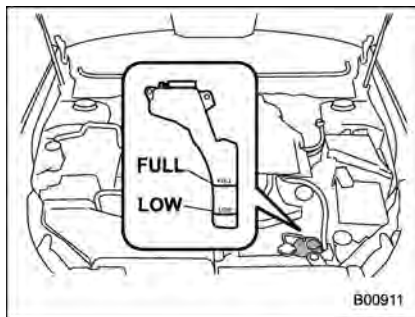

6. Pour the coolant and fill to the reservoir tank's "FULL" level mark.

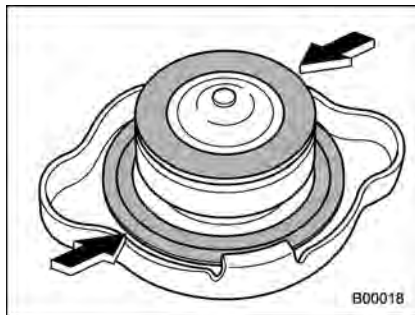

7. Put the radiator cap back on and tighten firmly. At this time, make sure that the rubber gasket in the radiator cap is correctly in place.

8. Start and race the engine at 2,000 to 3,000 rpm for 5 to 6 times within 40 seconds.

9. Stop the engine and wait until the coolant cools down (122 to 140°F [50 to 60°C]). If there is any loss of coolant, add coolant to the radiator's filler neck and to the reserve tank's "FULL" level.

10. Put the radiator cap and reservoir cap back on and tighten firmly.

Air cleaner element



WARNING

Do not operate the engine with the air cleaner element removed. The air cleaner element not only filters intake air but also stops flames if the engine backfires. If the air cleaner element is not installed when the engine backfires, you could be burned.



CAUTION

When replacing the air cleaner element, use a genuine SUBARU air cleaner element. If it is not used, there is the possibility of causing a negative effect to the engine.

The air cleaner element functions as a filter screen. When the element is perforated or removed, engine wear will be excessive and engine life shortened.

The air cleaner element is a dry type. It is unnecessary to clean or wash the element.

■ Replacing the air cleaner element

Replace the air cleaner element according to the maintenance schedule in the "Warranty and Maintenance Booklet". Under extremely dusty conditions, replace it more frequently. It is recommended that you always use genuine SUBARU parts.

▼ Non-turbo models

1. Remove the air intake duct (except 3.6 L models). For the method to remove the air intake duct, refer to "Removing air intake duct" 11-7.

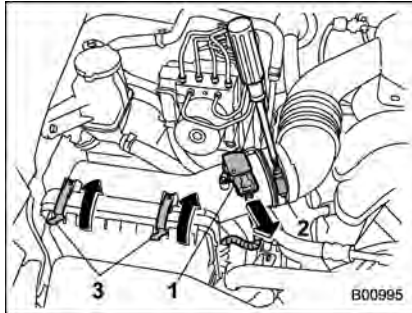

- 1) Connector
- 2) Clamp
- 3) Clips

2. Unplug the connector that is attached

to the top of the air cleaner case.

3. Loosen the screw of the clamp.

4. Unsnap the two clips holding the air cleaner case cover.

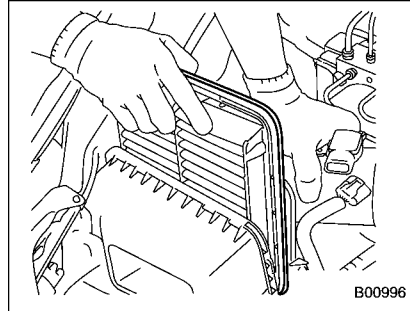

5. Open the air cleaner case cover and remove the air cleaner element.

6. Clean the inside of the air cleaner cover and case with a damp cloth and install a new air cleaner element.

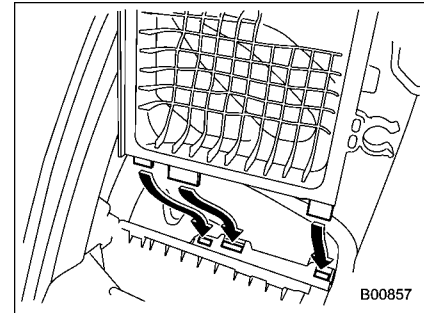

7. To install the air cleaner case cover, insert the three projections on the air cleaner case cover into the slits on the air cleaner case and then snap the two clips on the air cleaner case cover.

▼ Turbo models

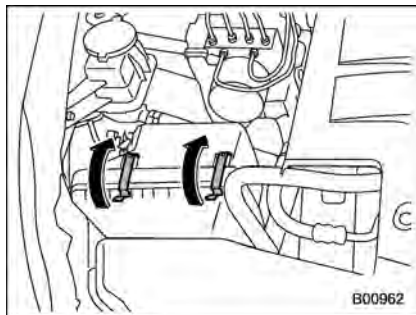

1. Unsnap the two clamps holding the air cleaner case cover.

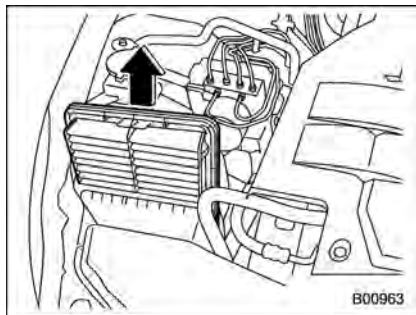

2. Open the air cleaner case cover and remove the air cleaner element.

3. Clean the inside of the air cleaner cover and case with a damp cloth and install a new air cleaner element.

4. Snap the two clamps on the air cleaner case cover.

Spark plugs

It may be difficult to replace the spark plugs. It is recommended that you have the spark plugs replaced by your SUBARU dealer.

The spark plugs should be replaced according to the maintenance schedule in the "Warranty and Maintenance Booklet".

■ Recommended spark plugs

2.5 L non-turbo models:

SIFR6A11 (NGK)

2.5 L turbo models:

SILFR6B8 (NGK)

3.6 L models:

SILFR6C11 (NGK)

Drive belts

It is unnecessary to check the deflection of the drive belt periodically because your engine is equipped with an automatic belt tension adjuster. However, replacement of the belt should be done according to the maintenance schedule in the "Warranty and Maintenance Booklet". Consult your SUBARU dealer for replacement.

If the belt is loose, cracked or worn, contact your SUBARU dealer.

Manual transmission oil

■ Checking the oil level

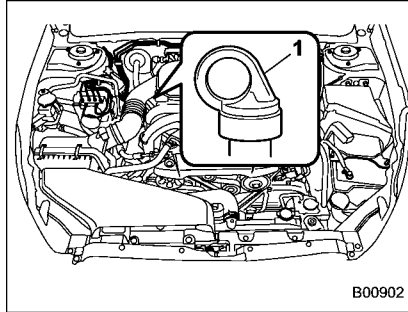

Non-turbo models

- 1) Yellow handle

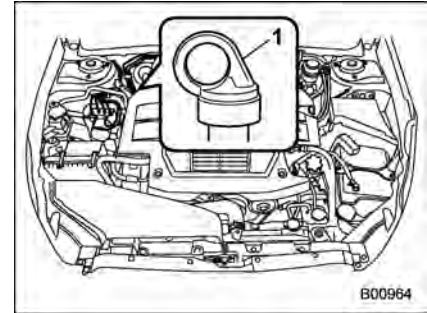

Turbo models

- 1) Yellow handle

Check the oil level monthly.

1. Park the vehicle on a level surface and stop the engine.
2. Pull out the level gauge, wipe it clean, and insert it again.

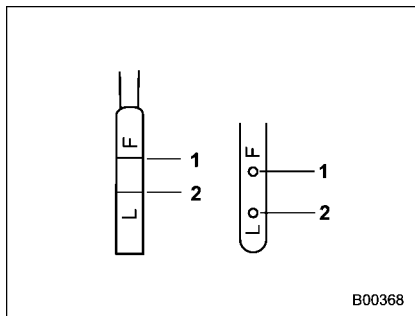

- 1) Upper level
- 2) Lower level

3. Pull out the level gauge again and check the oil level on it. If it is below the lower level, add oil through the level gauge hole to bring the level up to the upper level.



CAUTION

Be careful not to spill manual transmission oil when adding it. If oil touches the exhaust pipe, it may cause a bad smell, smoke, and/or a fire. If oil gets on the exhaust pipe, be sure to wipe it off.

Recommended grade and viscosity

Each oil manufacturer has its own base oils and additives. Never use different brands together.

Oil grade:

API classification GL-5

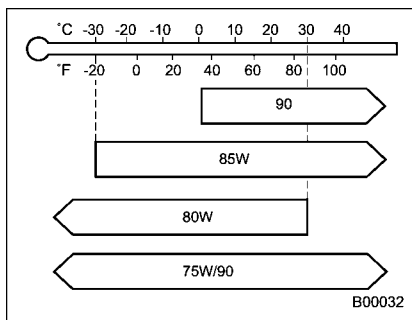

SAE viscosity No. and applicable temperature

Automatic transmission fluid

Checking the fluid level

The automatic transmission fluid expands largely as its temperature rises; the fluid level differs according to fluid temperature. Therefore, there are two different scales for checking the level of hot fluid and cold fluid on the level gauge.

Though the fluid level can be checked without warming up the fluid on the "COLD" range, we recommend checking the fluid level when the fluid is at operating temperature.

Checking the fluid level when the fluid is hot

Check the fluid level monthly.

1. Drive the vehicle several miles to raise the temperature of the transmission fluid up to normal operating temperature; 158 to 176°F (70 to 80°C) is normal.
2. Park the vehicle on a level surface and set the parking brake.
3. First shift the select lever in each position. Then shift it in the "P" position, and run the engine at idling speed.

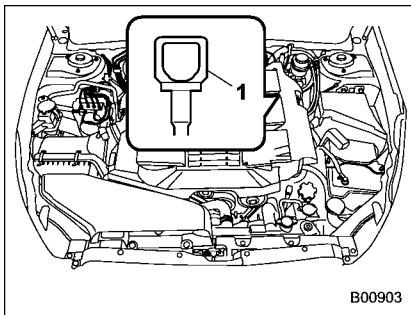

B00903

- 1) Yellow handle

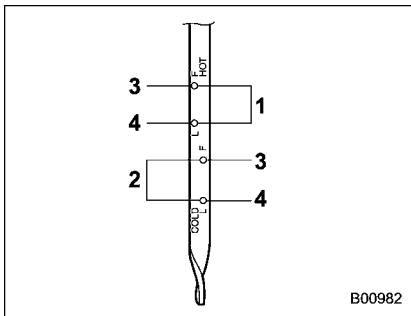

B00982

- 1) HOT range
 - 2) COLD range
 - 3) Upper level
 - 4) Lower level
4. Pull out the level gauge and check the

fluid level on the gauge. If it is below the lower level on the "HOT" range, add the recommended automatic transmission fluid up to the upper level.

▼ Checking the fluid level when the fluid is cold

When the fluid level has to be checked without time to warm up the automatic transmission, check to see that the fluid level is between the lower level and upper level on the "COLD" range. If it is below that range, add fluid up to the upper level. Be careful not to overfill.



CAUTION

Be careful not to spill automatic transmission fluid when adding it. If automatic transmission fluid touches the exhaust pipe, it may cause a bad smell, smoke, and/or a fire. If automatic transmission fluid gets on the exhaust pipe, be sure to wipe it off.

■ Recommended fluid

Use one of the following types of automatic transmission fluid.

- SUBARU ATF
- IDEMITSU ATF HP

NOTE

Using any non-specified type of automatic transmission fluid could result in damage inside the transmission. When replacing the automatic transmission fluid, be sure to use the specified type above.

Continuously variable transmission fluid

There is no continuously variable transmission fluid level gauge. It is unnecessary to check the continuously variable transmission fluid level. However, if necessary, we recommend that you consult your SUBARU dealer for inspection.

Front differential gear oil (AT and CVT models)

■ Checking the oil level

NOTE

There are no differential oil level gauges for CVT models.

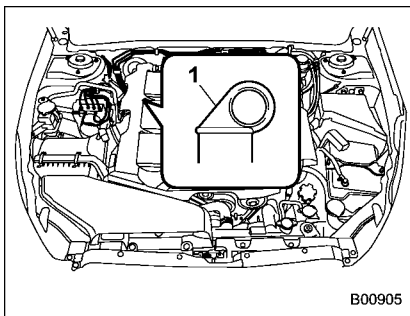

- 1) Yellow handle

1. Park the vehicle on a level surface and stop the engine.
2. Pull out the level gauge, wipe it clean, and insert it again.

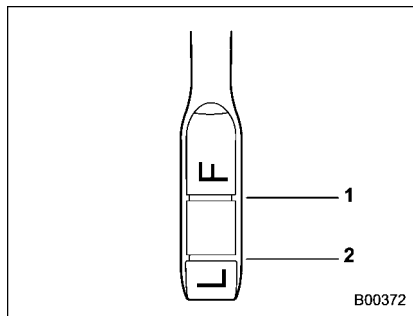

- 1) Upper level
- 2) Lower level

3. Pull out the level gauge again and check the oil level on it. If it is below the lower level, add oil to bring the level up to the upper level.

CAUTION

Be careful not to spill front differential gear oil when adding it. If oil touches the exhaust pipe, it may cause a bad smell, smoke, and/or a fire. If oil gets on the exhaust pipe, be sure to wipe it off.

■ Recommended grade and viscosity

Each oil manufacturer has its own base oils and additives. Never use different brands together.

Oil grade:

API classification GL-5

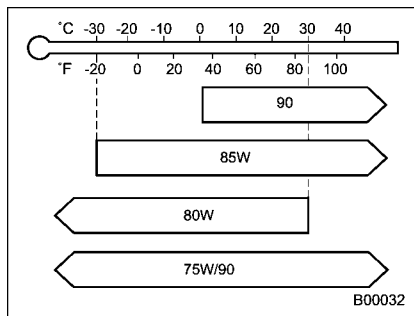

SAE viscosity No. and applicable temperature

Rear differential gear oil

■ Checking the gear oil level

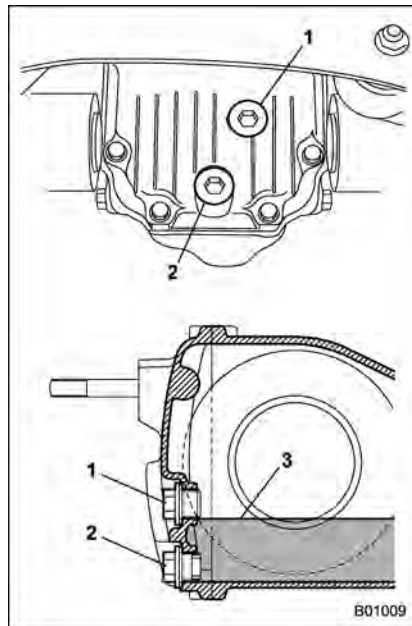

CVT models (Legacy)

- 1) Filler plug
- 2) Drain plug

- 3) Oil level

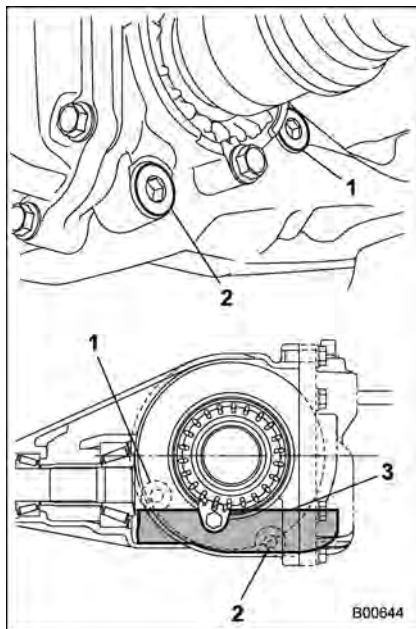

3.6 L models

- 1) Filler plug
- 2) Drain plug
- 3) Oil level

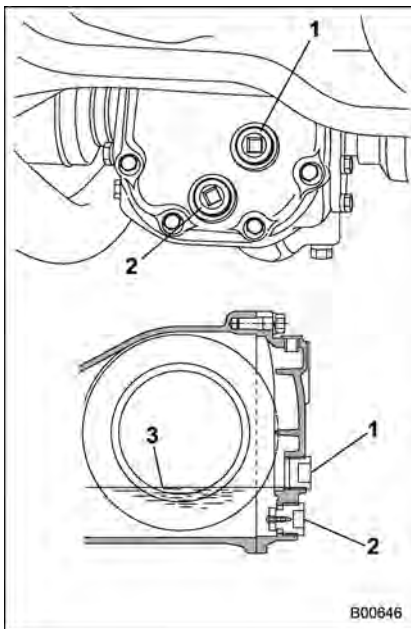

Others

- 1) Filler plug
- 2) Drain plug
- 3) Oil level

Remove the plug from the filler hole and check the oil level. The oil level should be kept even with the bottom of the filler hole.

If the oil level is below the bottom edge of the hole, add oil through the filler hole to raise the level.

CAUTION

- Be careful not to spill rear differential gear oil when adding it. If rear differential gear oil touches the exhaust pipe, it may cause a bad smell, smoke, and/or a fire. If rear differential gear oil gets on the exhaust pipe, be sure to wipe it off.
- If the vehicle requires frequent refilling, there may be an oil leak. If you suspect a problem, have the vehicle checked at your SUBARU dealer.

Recommended grade and viscosity

Each oil manufacturer has its own base oils and additives. Never use different brands together.

Oil grade:

API classification GL-5

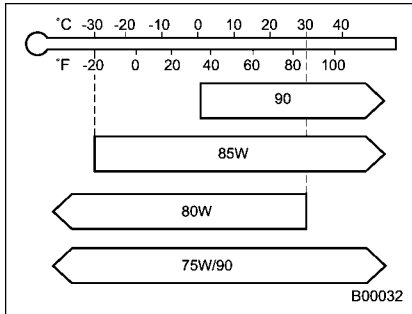

SAE viscosity No. and applicable temperature

Power steering fluid

■ Checking the fluid level

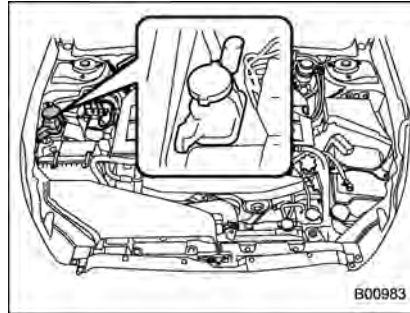

⚠ WARNING

Be careful not to burn yourself because the fluid may be hot.

⚠ CAUTION

- When power steering fluid is being added, use only clean fluid, and be careful not to allow any dirt into the tank. And never use different brands together.
- Avoid spilling fluid when adding it in the tank.

- Be careful not to spill power steering fluid when adding it. If power steering fluid touches the exhaust pipe, it may cause a bad smell, smoke, and/or a fire. If power steering fluid gets on the exhaust pipe, be sure to wipe it off.

The power steering fluid expands greatly as its temperature rises; the fluid level differs according to fluid temperature. Therefore, the reservoir tank has two different checking ranges for hot and cold fluids.

Check the power steering fluid level monthly.

1. Park the vehicle on a level surface, and stop the engine.

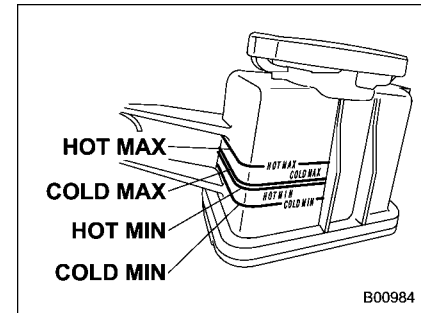

2. Check the fluid level of the reservoir tank.

When the fluid is hot after the vehicle has been run: Check that the oil level is between "HOT MIN" and "HOT MAX" on the surface of the reservoir tank.

When the fluid is cool before the vehicle is run: Check that the oil level is between "COLD MIN" and "COLD MAX" on the surface of the reservoir tank.

3. If the fluid level is lower than the applicable "MIN" line, add the recommended fluid as necessary to bring the level between the "MIN" and "MAX" line.

If the fluid level is extreme low, it may indicate possible leakage. Consult your SUBARU dealer for inspection.

Recommended fluid

Use one of the following types of automatic transmission fluid.

- SUBARU ATF
- IDEMITSU ATF HP
- "Dexron III" Type Automatic Transmission Fluid

Brake fluid

Checking the fluid level

WARNING

- Never let brake fluid contact your eyes because brake fluid can be harmful to your eyes. If brake fluid gets in your eyes, immediately flush them thoroughly with clean water. For safety, when performing this work, wearing eye protection is advisable.
- Brake fluid absorbs moisture from the air. Any absorbed moisture can cause a dangerous loss of braking performance.
- If the vehicle requires frequent refilling, there may be a leak. If you suspect a problem, have the vehicle checked at your SUBARU dealer.

CAUTION

- Never use different brands of brake fluid together. Also, avoid mixing DOT 3 and DOT 4 brake fluids even if they are of the same brand.

- When adding brake fluid, be careful not to allow any dirt into the reservoir.
- Never splash the brake fluid over painted surfaces or rubber parts. Alcohol contained in the brake fluid may damage them.
- Be careful not to spill brake fluid when adding it. If brake fluid touches the exhaust pipe, it may cause a bad smell, smoke, and/or a fire. If brake fluid gets on the exhaust pipe, be sure to wipe it off.

Check the fluid level monthly.

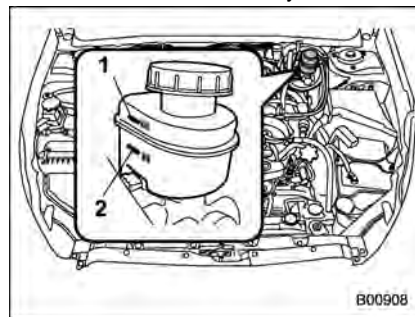

- 1) "MAX" level mark
- 2) "MIN" level mark

Check the fluid level on the outside of the reservoir. If the level is below "MIN", add the recommended brake fluid to "MAX". Use only brake fluid from a sealed container.

■ Recommended brake fluid

FMVSS No. 116, fresh DOT 3 or 4 brake fluid

CAUTION

Never use different brands of brake fluid together. Also, avoid mixing DOT 3 and DOT 4 brake fluids even if they are the same brand.

Clutch fluid (MT models)

■ Checking the fluid level

WARNING

Never let clutch fluid contact your eyes because clutch fluid can be harmful to your eyes. If clutch fluid gets in your eyes, immediately flush them thoroughly with clean water. For safety, when performing this work, wearing eye protection is advisable.

CAUTION

- Clutch fluid absorbs moisture from the air. Any absorbed moisture can cause improper clutch operation.
- If the vehicle requires frequent refilling, there may be a leak. If you suspect a problem, have the vehicle checked at your SUBARU dealer.
- Never use different brands of clutch fluid together.
- When clutch fluid is added, be careful not to allow any dirt into the tank.

- Never splash the clutch fluid over painted surfaces or rubber parts. Alcohol contained in the clutch fluid may damage them.
- Be careful not to spill clutch fluid when adding it. If clutch fluid touches the exhaust pipe, it may cause a bad smell, smoke, and/or a fire. If clutch fluid gets on the exhaust pipe, be sure to wipe it off.

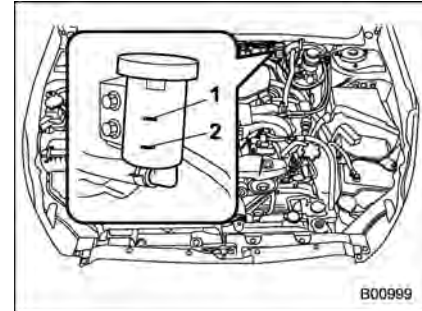

- 1) "MAX" level mark
- 2) "MIN" level mark

Check the fluid level on the outside of the reservoir. If the level is below "MIN" level mark, add the recommended clutch fluid to "MAX" level mark.

Use only clutch fluid from a sealed container.

■ Recommended clutch fluid

FMVSS No. 116, fresh DOT 3 or 4 brake fluid



CAUTION

Avoid mixing DOT 3 and DOT 4 brake fluids even if they are of the same brand.

Brake booster

If the brake booster does not operate as described in the following procedure, have it checked by your SUBARU dealer.

1. With the engine off, depress the brake pedal several times, applying the same pedal force each time. The distance the pedal travels should not vary.
2. With the brake pedal depressed, start the engine. The pedal should move slightly down to the floor.
3. With the brake pedal depressed, stop the engine and keep the pedal depressed for 30 seconds. The pedal height should not change.
4. Start the engine again and run for approximately 1 minute then turn it off. Depress the brake pedal several times to check the brake booster. The brake booster operates properly if the pedal stroke decreases with each depression.

NOTE

When you depress the brake pedal strongly or suddenly, the following phenomena occur. However, even though these occur, they do not indicate any malfunctions, and the brake assist system is operating properly.

- You might feel that the brake pedal

is applied by lighter force and generates a greater braking force.

- You might hear the sound of ABS operating from the engine compartment.

Brake assist is not a system that brings more braking ability to the vehicle beyond its breaking capability.

Brake pedal

Check the brake pedal free play and reserve distance according to the maintenance schedule in the "Warranty and Maintenance Booklet".

■ Checking the brake pedal free play

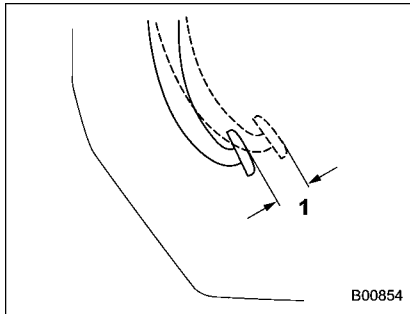

- 1) 0.08 – 0.18 in (2 – 5 mm)

Stop the engine and firmly depress the brake pedal several times. Lightly pull the brake pedal up with one finger to check the free play with a force of less than 2 lbf (10 N, 1 kgf).

If the free play is not within proper specification, contact your SUBARU dealer.

■ Checking the brake pedal reserve distance

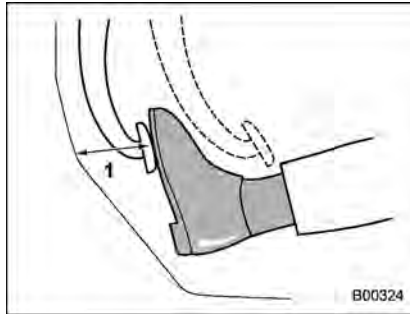

- 1) More than 2.56 in (65 mm)

Depress the pedal with a force of approximately 66 lbf (294 N, 30 kgf) and measure the distance between the upper surface of the pedal pad and the floor.

When the measurement is smaller than the specification, or when the pedal does not operate smoothly, contact with your SUBARU dealer.

Clutch pedal (MT models)

Check the clutch pedal free play and reserve distance according to the maintenance schedule in the "Warranty and Maintenance Booklet".

■ Checking the clutch function

Check the clutch engagement and disengagement.

1. With the engine idling, check that there are no abnormal noises when the clutch pedal is depressed, and that shifting into 1st or reverse feels smooth.
2. Start the vehicle by releasing the pedal slowly to check that the engine and transmission smoothly couple without any sign of slippage.

■ Checking the clutch pedal free play

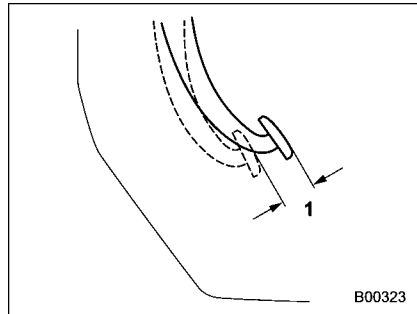

1) 0.19 – 0.44 in (5 – 11 mm)

Lightly press the clutch pedal down with your finger until you feel resistance, and check the free play.

If the free play is not within proper specification, contact your SUBARU dealer.

Replacement of brake pad and lining



CAUTION

If you continue to drive despite the scraping noise from the audible brake pad wear indicator, it will result in the need for costly brake rotor repair or replacement.

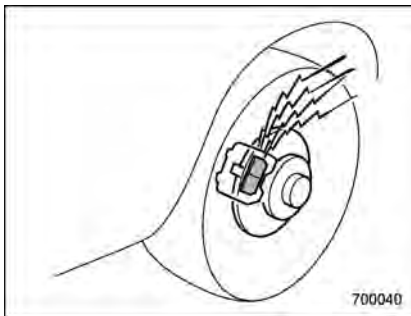

The right front disc brake and the right rear disc brake have audible wear indicators on the brake pads. If the brake pads wear close to their service limit, the wear indicator makes a very audible scraping noise when the brake pedal is applied.

If you hear this scraping noise each time

you apply the brake pedal, have the brake pads serviced by your SUBARU dealer as soon as possible.

■ Breaking-in of new brake pads and linings

When replacing the brake pad or lining, use only genuine SUBARU parts. After replacement, the new parts must be broken in as follows:

▼ Brake pad and lining

While maintaining a speed of 30 to 40 mph (50 to 65 km/h), step on the brake pedal lightly. Repeat this five or more times.

▼ Parking brake lining

The break-in maintenance for the parking brake linings should be performed at a SUBARU dealer.

Tires and wheels

■ Types of tires

You should be familiar with type of tires present on your vehicle.

▼ All season tires

The factory-installed tires on your new vehicle except 2.5 L turbo models are all season tires.

All season tires are designed to provide an adequate measure of traction, handling and braking performance in year-round driving including snowy and icy road conditions. However all season tires do not offer as much traction performance as winter (snow) tires in heavy or loose snow or on icy roads.

All season tires are identified by "ALL SEASON" and/or "M+S" (Mud & Snow) on the tire sidewall.

▼ Summer tires

The factory-installed tires on your new 2.5 L turbo models are summer tires. Summer tires are high-speed capability tires best suited for highway driving under dry conditions.

Summer tires are inadequate for driving on slippery roads such as on snow-covered or icy roads.

If you drive your vehicle on snow-covered

or icy roads, we strongly recommend the use of winter (snow) tires.

When installing winter tires, be sure to replace all four tires.

▼ Winter (snow) tires

Winter tires are best suited for driving on snow-covered and icy roads. However winter tires do not perform as well as summer tires and all season tires on roads other than snow-covered and icy roads.

■ Tire pressure monitoring system (TPMS) (if equipped)

The tire pressure monitoring system provides the driver with a warning message by sending a signal from a sensor that is installed in each wheel when tire pressure is severely low. The tire pressure monitoring system will activate only when the vehicle is driven. Also, this system may not react immediately to a sudden drop in tire pressure (for example, a blow-out caused by running over a sharp object).

If you adjust the tire pressures in a warm garage and will then drive the vehicle in cold outside air, the resulting drop in tire pressures may cause the low tire pressure warning light to illuminate. To avoid this problem when adjusting the tire pressures in a warm garage, inflate the tires to pressures higher than those shown on the

tire placard. Specifically, inflate them by an extra 1 psi (6.9 kPa, 0.07 kgf/cm²) for every difference of 10°F (5.6°C) between the temperature in the garage and the temperature outside. By way of example, the following table shows the required tire pressures that correspond to various outside temperatures when the temperature in the garage is 60°F (15.6°C).

Example:

Tire size: P215/70R16 99S, P225/60R17 98T

Standard tire pressures:

Front: 32 psi (220 kPa, 2.2 kgf/cm²)

Rear: 30 psi (210 kPa, 2.1 kgf/cm²)

Garage temperature: 60°F (15.6°C)

| Outside temperature | Adjusted pressure [psi (kPa, kgf/cm ²)] | |
|---------------------|---|----------------|
| | Front | Rear |
| 30°F (-1°C) | 35 (240, 2.4) | 33 (230, 2.3) |
| 10°F (-12°C) | 37 (255, 2.55) | 35 (240, 2.4) |
| -10°F (-23°C) | 39 (270, 2.7) | 37 (255, 2.55) |

Example:

Tire size: P205/60R16 91V, P215/50R17 90V, P225/50R17 93V, 225/45R18 91W

Standard tire pressures:

Front: 33 psi (230 kPa, 2.3 kgf/cm²)

Rear: 32 psi (220 kPa, 2.2 kgf/cm²)
 Garage temperature: 60°F (15.6°C)

| Outside temperature | Adjusted pressure [psi (kPa, kgf/cm ²)] | |
|---------------------|---|----------------|
| | Front | Rear |
| 30°F (-1°C) | 36 (250, 2.5) | 35 (240, 2.4) |
| 10°F (-12°C) | 38 (265, 2.65) | 37 (255, 2.55) |
| -10°F (-23°C) | 40 (280, 2.8) | 39 (270, 2.7) |

If the low tire pressure warning light illuminates when you drive the vehicle in cold outside air after adjusting the tire pressures in a warm garage, re-adjust the tire pressures using the method described above. Then, increase the vehicle speed to at least 20 mph (32 km/h) and check to see that the low tire pressure warning light goes off a few minutes later. If the low tire pressure warning light does not go off, the tire pressure monitoring system may not be functioning normally. In this event, go to a SUBARU dealer to have the system inspected as soon as possible.

While the vehicle is driven, friction between tires and the road surface causes the tires to warm up. After illumination of the low tire pressure warning light, any increase in the tire pressures caused by an increase in the outside air temperature

or by an increase in the temperature in the tires can cause the low tire pressure warning light to go off.

System resetting is necessary when the wheels are changed (for example, a switch to snow tires) and new TPMS valves are installed on the newly fitted wheels. Have this work performed by a SUBARU dealer following wheel replacement.

It may not be possible to install TPMS valves on certain wheels that are on the market. Therefore, if you change the wheels (for example, a switch to snow tires), use wheels that have the same part number as the standard-equipment wheels. Without four operational TPMS valve/sensors on the wheels, the TPMS will not fully function and the warning light in the instrument panel will illuminate steadily after blinking for approximately one minute.

When a tire is replaced, adjustments are necessary to ensure continued normal operation of the tire pressure monitoring system. As with wheel replacement, therefore, you should have the work performed by a SUBARU dealer.

WARNING

If the low tire pressure warning light does not illuminate briefly after the ignition switch is turned ON or the light illuminates steadily after blinking for approximately one minute, you should have your Tire Pressure Monitoring System checked at a SUBARU dealer as soon as possible.

If this light illuminates while driving, never brake suddenly and keep driving straight ahead while gradually reducing speed. Then slowly pull off the road to a safe place. Otherwise an accident involving serious vehicle damage and serious personal injury could occur.

If this light still illuminates while driving after adjusting the tire pressure, a tire may have significant damage and a fast leak that causes the tire to lose air rapidly. If you have a flat tire, replace it with a spare tire as soon as possible.

When a spare tire is mounted or a wheel rim is replaced without the original pressure sensor/transmitter being transferred, the low tire pressure warning light will illuminate steadily after blinking for approxi-

mately one minute. This indicates the TPMS is unable to monitor all four road wheels. Contact your SUBARU dealer as soon as possible for tire and sensor replacement and/or system resetting. If the light illuminates steadily after blinking for approximately one minute, promptly contact a SUBARU dealer to have the system inspected.

■ Tire inspection

Check on a daily basis that the tires are free from serious damage, nails, and stones. At the same time, check the tires for abnormal wear.

Contact your SUBARU dealer immediately if you find any problem.

NOTE

● **When the wheels and tires strike curbs or are subjected to harsh treatment as when the vehicle is driven on a rough surface, they can suffer damage that cannot be seen with the naked eye. This type of damage does not become evident until time has passed. Try not to drive over curbs, potholes or on other rough surfaces. If doing so is unavoidable, keep the vehicle's speed down to a walking pace or less, and**

approach the curbs as squarely as possible. Also, make sure the tires are not pressed against the curb when you park the vehicle.

● **If you feel unusual vibration while driving or find it difficult to steer the vehicle in a straight line, one of the tires and/or wheels may be damaged. Drive slowly to the nearest authorized SUBARU dealer and have the vehicle inspected.**

■ Tire pressures and wear

Maintaining the correct tire pressures helps to maximize the tires' service lives and is essential for good running performance. Check and, if necessary, adjust the pressure of each tire (including the spare) at least once a month (for example, during a fuel stop) and before any long journey.

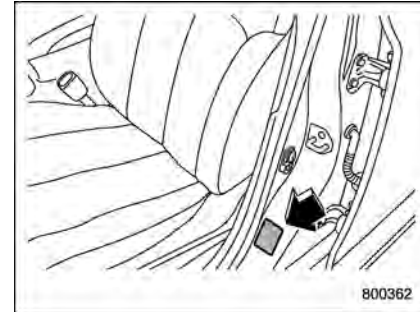

Check the tire pressures when the tires are cold. Use a pressure gauge to adjust the tire pressures to the values shown on the tire placard. The tire placard is located on the door pillar on the driver's side.

Driving even a short distance warms up the tires and increases the tire pressures. Also, the tire pressures are affected by the outside temperature. It is best to check tire pressure outdoors before driving the vehicle.

When a tire becomes warm, the air inside it expands, causing the tire pressure to increase. Be careful not to mistakenly release air from a warm tire to reduce its pressure.

NOTE

- The air pressure in a tire increases by approximately 4.3 psi (30 kPa, 0.3 kgf/cm²) when the tire becomes warm.
- The tires are considered cold when the vehicle has been parked for at least 3 hours or has been driven less than 1 mile (1.6 km).



WARNING

Do not let air out of warm tires to adjust pressure. Doing so will result in low tire pressure.

Incorrect tire pressures detract from controllability and ride comfort, and they cause the tires to wear abnormally.

- **Correct tire pressure** (tread worn evenly)

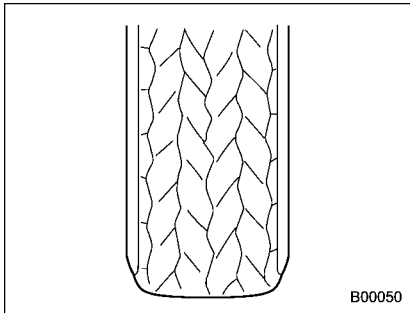

Roadholding is good, and steering is responsive. Rolling resistance is low, so fuel consumption is also lower.

- **Abnormally low tire pressure** (tread worn at shoulders)

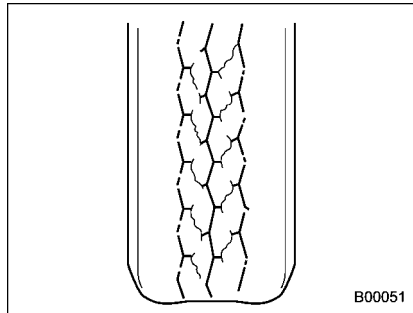

Rolling resistance is high, so fuel consumption is also higher.

- **Abnormally high tire pressure** (tread worn in center)

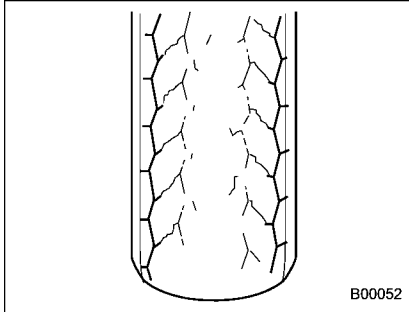

Ride comfort is poor. Also, the tire magnifies the effects of road-surface bumps and dips, possibly resulting in vehicle damage.

WARNING

Driving at high speeds with excessively low tire pressures can cause the tires to deform severely and to rapidly become hot. A sharp increase in temperature could cause tread separation, and destruction of the tires. The resulting loss of vehicle control could lead to an accident.

■ Wheel balance

Each wheel was correctly balanced when your vehicle was new, but the wheels will become unbalanced as the tires become worn during use. Wheel imbalance causes the steering wheel to vibrate slightly at certain vehicle speeds and detracts from the vehicle's straight-line stability. It can also cause steering and suspension system problems and abnormal tire wear. If you suspect that the wheels are not correctly balanced, have them checked and adjusted by your SUBARU dealer. Also have them adjusted after tire repairs and after tire rotation.

NOTE

Loss of correct wheel alignment* causes the tires to wear on one side and reduces the vehicle's running stability. Contact your SUBARU dealer if you notice abnormal tire wear.

*: The suspension system is designed to hold each wheel at a certain alignment (relative to the other wheels and to the road) for optimum straight-line stability and cornering performance.

■ Wear indicators

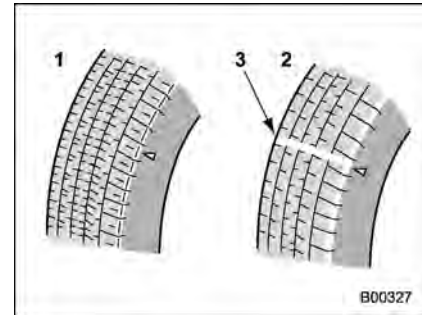

- 1) New tread
- 2) Worn tread
- 3) Tread wear indicator

Each tire incorporates a tread wear indicator, which becomes visible when the depth of the tread grooves decreases to 0.063 in (1.6 mm). A tire must be replaced when the tread wear indicator appears as a solid band across the tread.

WARNING

When a tire's tread wear indicator becomes visible, the tire is worn beyond the acceptable limit and must be replaced immediately. With a tire in this condition, driving at high speeds in wet weather can

cause the vehicle to hydroplane. The resulting loss of vehicle control can lead to an accident.

NOTE

For safety, inspect the tire tread regularly and replace the tires before their tread wear indicators become visible.

■ Tire rotation direction mark

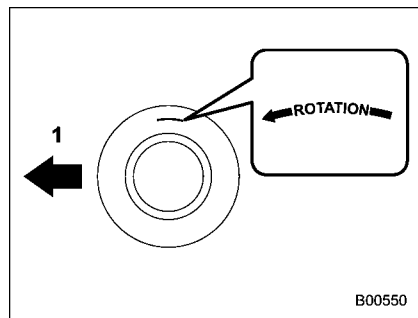

Example of tire rotation direction mark

1) Front

If the tire has a rotation direction specification, the tire rotation direction mark is placed on its sidewall.

When you install a tire that has the tire rotation direction mark, install the tire with

the direction mark facing forward.

■ Tire rotation

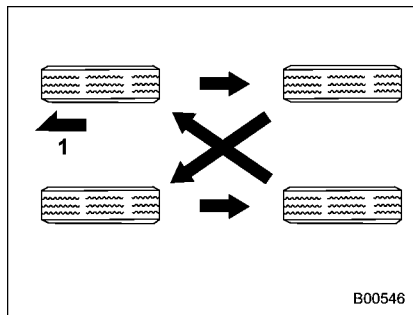

Vehicles equipped with 4 non-unidirectional tires

1) Front

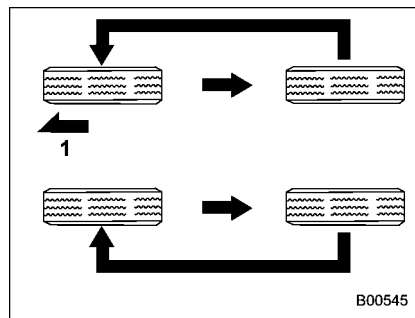

Vehicles equipped with unidirectional tires

1) Front

Tire wear varies from wheel to wheel. To maximize the life of each tire and ensure that the tires wear uniformly, it is best to rotate the tires every 7,500 miles (12,000 km). Move the tires to the positions shown in the applicable illustration each time they are rotated.

Replace any damaged or unevenly worn tire at the time of rotation. After tire rotation, adjust the tire pressures and make sure the wheel nuts are correctly tightened.

After driving approximately 600 miles (1,000 km), check the wheel nuts again and retighten any nut that has become loose.

■ Tire replacement

The wheels and tires are important and integral parts of your vehicle's design; they cannot be changed arbitrarily. The tires fitted as standard equipment are optimally matched to the characteristics of the vehicle and were selected to give the best possible combination of running performance, ride comfort, and service life. It is essential for every tire to have a size and construction matching those shown on the tire placard and to have a speed symbol and load index matching those shown on the tire placard.

Using tires of a non-specified size detracts from controllability, ride comfort, braking performance, speedometer accuracy and odometer accuracy. It also creates incorrect body-to-tire clearances and inappropriately changes the vehicle's ground clearance.

All four tires must be the same in terms of manufacturer, brand (tread pattern), construction, and size. You are advised to replace the tires with new ones that are identical to those fitted as standard equipment.

For safe vehicle operation, SUBARU recommends replacing all four tires at the same time.



WARNING

- **All four tires must be the same in terms of manufacturer, brand (tread pattern), construction, degree of wear, speed symbol, load index and size. Mixing tires of different types, sizes or degrees of wear can result in damage to the vehicle's power train. Use of different types or sizes of tires can also dangerously reduce controllability and braking performance and can lead to an accident.**
- **Use only radial tires. Do not use radial tires together with belted bias tires and/or bias-ply tires. Doing so can dangerously reduce controllability, resulting in an accident.**

■ Wheel replacement

When replacing wheels due, for example, to damage, make sure the replacement wheels match the specifications of the wheels that are fitted as standard equipment. Replacement wheels are available from SUBARU dealers.



WARNING

Use only those wheels that are specified for your vehicle. Wheels not meeting specifications could interfere with brake caliper operation and may cause the tires to rub against the wheel well housing during turns. The resulting loss of vehicle control could lead to an accident.

Aluminum wheels

Aluminum wheels can be scratched and damaged easily. Handle them carefully to maintain their appearance, performance, and safety.

- When any of the wheels is removed and replaced for tire rotation or to change a flat, always check the tightness of the wheel nuts after driving approximately 600 miles (1,000 km). If any nut is loose, tighten it to the specified torque.
- Never apply oil to the threaded parts, wheel nuts, or tapered surface of the wheel.
- Never let the wheel rub against sharp protrusions or curbs.
- When wheel nuts, balance weights, or the center cap is replaced, be sure to replace them with genuine SUBARU parts designed for aluminum wheels.

Windshield washer fluid

 **CAUTION**

Never use engine coolant as washer fluid because it could cause paint damage.

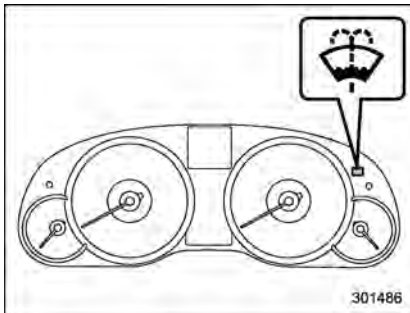

If you spray washer fluid on the windshield but the windshield washer fluid warning light illuminates or the supply of washer fluid runs out, add washer fluid in the tank.

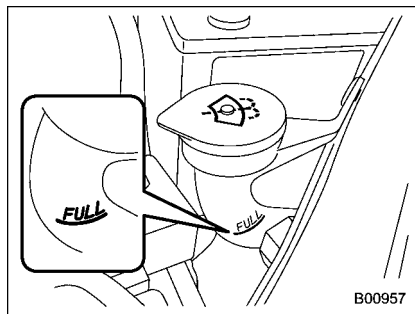
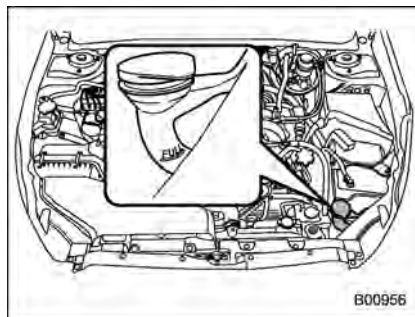

Remove the washer tank filler cap, then add fluid until it reaches the "FULL" mark on the tank.

Use windshield washer fluid. If windshield washer fluid is unavailable use clean water.

In areas where water freezes in winter, use an anti-freeze type windshield washer fluid. SUBARU Windshield Washer Fluid contains 58.5% methyl alcohol and 41.5% surfactant, by volume. Its freezing temperature varies according to how much it is diluted, as indicated in the following table.

| Washer Fluid Concentration | Freezing Temperature |
|----------------------------|----------------------|
| 30% | 10.4°F (-12°C) |
| 50% | -4°F (-20°C) |
| 100% | -49°F (-45°C) |

 **CAUTION**

Never use engine coolant as washer fluid because it could cause paint damage.

In order to prevent freezing of washer fluid, check the freezing temperatures in the table above when adjusting the fluid concentration to the outside temperature. If you fill the reservoir tank with a fluid with a different concentration from the one used previously, purge the old fluid from the piping between the reservoir tank and washer nozzles by operating the washer for a certain period of time. Otherwise, if

the concentration of the fluid remaining in the piping is too low for the outside temperature, it may freeze and block the nozzles.

 **CAUTION**

- **Adjust the washer fluid concentration appropriately for the outside temperature. If the concentration is inappropriate, sprayed washer fluid may freeze on the windshield and obstruct your view, and the fluid may freeze in the reservoir tank.**
- **State or local regulations on volatile organic compounds may restrict the use of methanol, a common windshield washer anti-freeze additive. Washer fluids containing non-methanol anti-freeze agents should be used only if they provide cold weather protection without damaging your vehicle's paint, wiper blades or washer system.**

Replacement of wiper blades

Grease, wax, insects, or other materials on the windshield or the wiper blade results in jerky wiper operation and streaking on the glass. If you cannot remove the streaks after operating the windshield washer or if the wiper operation is jerky, clean the outer surface of the windshield (or rear window) and the wiper blades using a sponge or soft cloth with a neutral detergent or mild-abrasive cleaner. After cleaning, rinse the windshield and wiper blades with clean water. The windshield is clean if beads do not form when you rinse the windshield with water.

 **CAUTION**

- **Do not clean the wiper blades with gasoline or a solvent, such as paint thinner or benzene. This will cause deterioration of the wiper blades.**
- **When you wish to raise the passenger-side wiper arm, first raise the driver-side wiper arm. Otherwise, the passenger-side wiper assembly and driver-side wiper assembly will touch each other, possibly resulting in scratches.**

- Return the passenger-side wiper arm to its original position before returning the driver-side wiper arm to its original position. Otherwise, the passenger-side wiper assembly and driver-side wiper assembly will touch each other, possibly resulting in scratches.
- When returning the raised wipers to the original positions, return the wipers slowly on the windshield by hand. Returning the wipers from the detached positions by the spring operation might change the shape of the wiper arm or scratch the windshield.

If you cannot eliminate the streaking even after following this method, replace the wiper blades using the following procedures.

■ Windshield wiper blade assembly

1. Raise the wiper arm off the windshield.

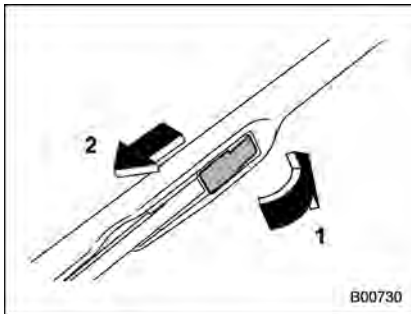

- 1) Open the cover
- 2) Pull down the wiper blade

2. Remove the wiper blade assembly by opening the cover and pulling it down in the direction shown in the illustration.
3. Install the wiper blade assembly to the wiper arm. Make sure that it locks in place.
4. Hold the wiper arm by hand and slowly lower it in position.

■ Windshield wiper blade rubber

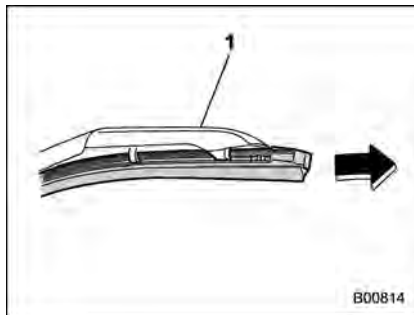

- 1) Support

1. Grasp the locked end of the blade rubber assembly and pull it firmly until the stoppers on the rubber are free of the support.

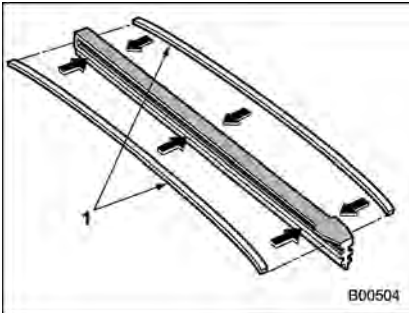

1) Metal spines

2. If the new blade rubber is not provided with two metal spines, remove the metal spines from the old blade rubber and install them in the new blade rubber.

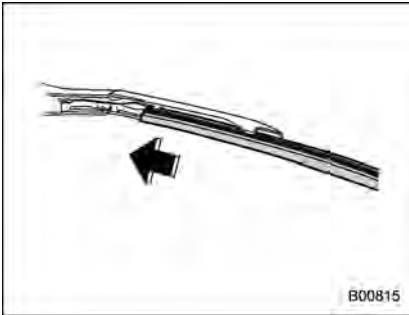

3. Align the claws of the support with the

grooves in the rubber and slide the blade rubber assembly into the support until it locks.

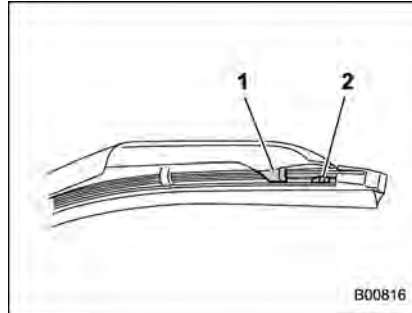

- 1) Claw
- 2) Stopper

4. Be sure to position the claws at the end of the support between the stoppers on the rubber as shown. If the rubber is not retained properly, the wiper blade may scratch the windshield.

■ Rear window wiper blade assembly (Outback)

1. Raise the wiper arm off the rear window.

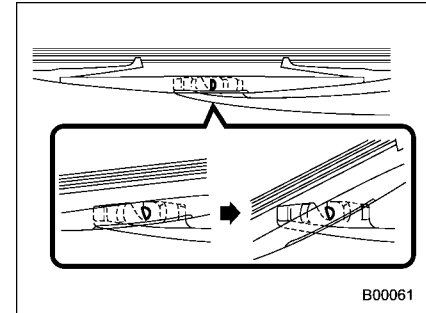

2. Turn the wiper blade assembly counterclockwise.

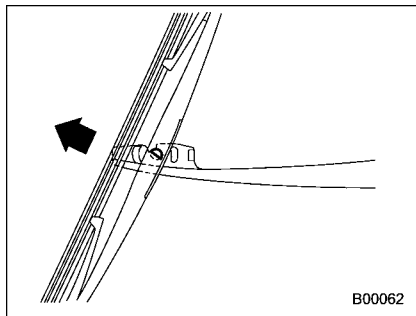

3. Pull the wiper blade assembly toward you to remove it from the wiper arm.

■ Rear window wiper blade rubber (Outback)

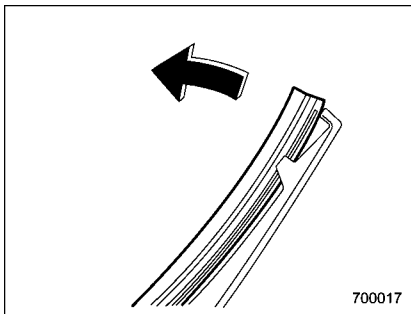

1. Pull out the end of the blade rubber assembly to unlock it from the plastic support.

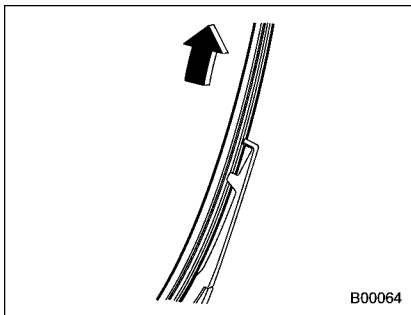

2. Pull the blade rubber assembly out of the plastic support.

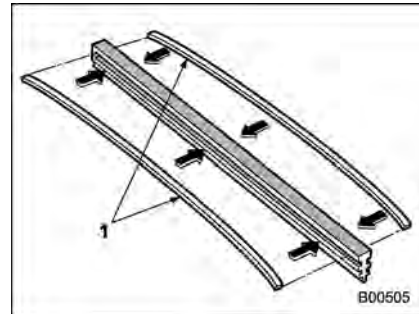

1) Metal spines

3. If the new blade rubber is not provided with two metal spines, remove the metal spines from the old blade rubber and install them in the new blade rubber.

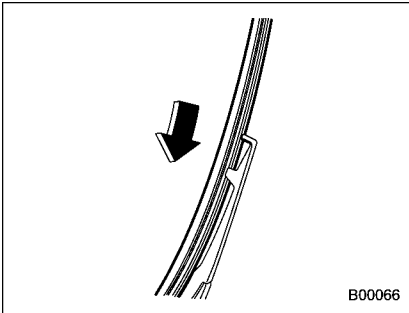

4. Align the claws of the plastic support with the grooves in the blade rubber assembly, then slide the blade rubber assembly into place.

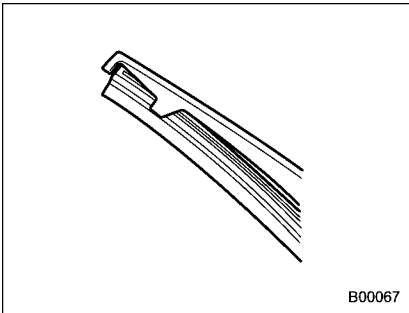

Securely retain both ends of the rubber with the stoppers on the plastic support

ends. If the rubber is not retained properly, the wiper may scratch the rear window glass.

5. Install the wiper blade assembly to the wiper arm. Make sure that it locks in place.
6. Hold the wiper arm by hand and slowly lower it in position.

Battery



WARNING

- Before beginning work on or near any battery, be sure to extinguish all cigarettes, matches, and lighters. Never expose a battery to an open flame or electric sparks. Batteries give off a gas which is highly flammable and explosive.
- For safety, in case an explosion does occur, wear eye protection or shield your eyes when working near any battery. Never lean over a battery.
- Do not let battery fluid contact eyes, skin, fabrics, or paint because battery fluid is a corrosive acid. If battery fluid gets on your skin or in your eyes, immediately flush the area with water thoroughly. Seek medical help immediately if acid has entered the eyes.

If battery fluid is accidentally swallowed, immediately drink a large amount of milk or water, and seek medical attention immediately.
- To lessen the risk of sparks,

remove rings, metal watchbands, and other metal jewelry. Never allow metal tools to contact the positive battery terminal and anything connected to it **WHILE** you are at the same time in contact with any other metallic portion of the vehicle because a short circuit will result.

- Keep everyone including children away from the battery.
- Charge the battery in a well-ventilated area.
- Battery posts, terminals, and related accessories contain lead and lead compounds, chemicals known to the State of California to cause cancer and reproductive harm. Batteries also contain other chemicals known to the State of California to cause cancer. Wash hands after handling.

CAUTION

Never use more than 10 amperes when charging the battery because it will shorten battery life.

It is unnecessary to periodically check the battery fluid level or periodically refill with

distilled water.

Fuses

CAUTION

Never replace a fuse with one having a higher rating or with material other than a fuse because serious damage or a fire could result.

The fuses are designed to melt during an overload to prevent damage to the wiring harness and electrical equipment. The fuses are located in two fuse boxes.

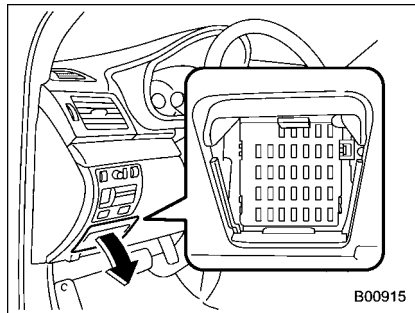

B00915

One is located under the instrument panel behind the fuse box cover on the driver's seat side. To remove the cover, pull it out.

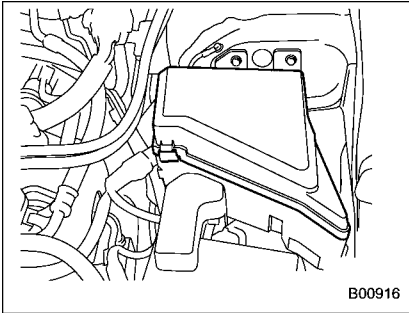

The other one is housed in the engine compartment.

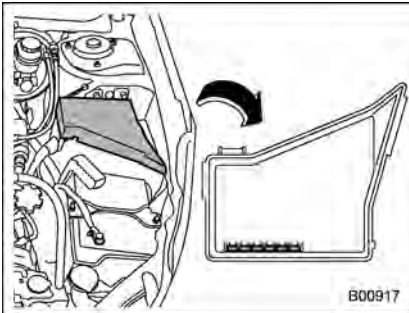

The spare fuses are stored in the main fuse box cover in the engine compartment.

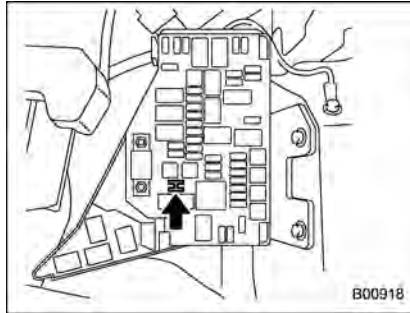

The fuse puller is stored in the main fuse box in the engine compartment.

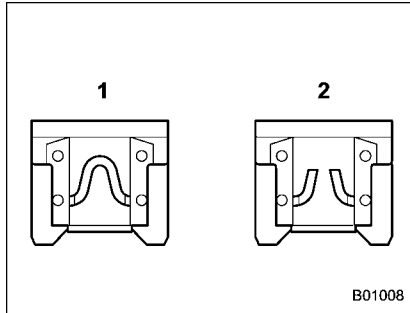

- 1) Good
- 2) Blown

If any lights, accessories or other electrical controls do not operate, inspect the

corresponding fuse. If a fuse has blown, replace it.

1. Turn the ignition switch to the "LOCK" position and turn off all electrical accessories.
2. Remove the cover.
3. Determine which fuse may be blown. Look at the back side of each fuse box cover and refer to "Fuses and circuits" 12-6.

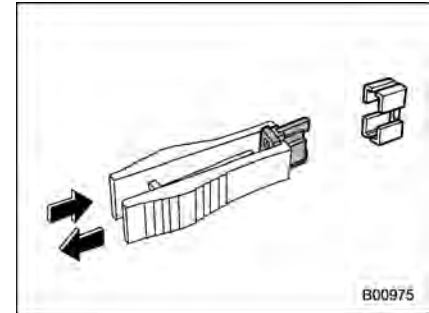

4. Pull out the fuse with the fuse puller.
5. Inspect the fuse. If it has blown, replace it with a spare fuse of the same rating.
6. If the same fuse blows again, this indicates that its system has a problem. Contact your SUBARU dealer for repairs.

Main fuse

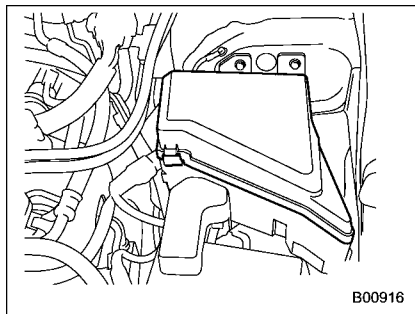

Main fuse box

The main fuses are designed to melt during an overload to prevent damage to the wiring harness and electrical equipment. Check the main fuses if any electrical component fails to operate (except the starter motor) and other fuses are good. A melted main fuse must be replaced. Use only replacements with the same specified rating as the melted main fuse. If a main fuse blows after it is replaced, have the electrical system checked by your nearest SUBARU dealer.

Installation of accessories

Always consult your SUBARU dealer before installing fog lights or any other electrical equipment in your vehicle. Such accessories may cause the electronic system to malfunction if they are incorrectly installed or if they are not suited for the vehicle. We recommend that you install only genuine SUBARU accessories on your vehicle.

Replacing bulbs

WARNING

Bulbs may become very hot while illuminated. Before replacing bulbs, turn off the lights and wait until the bulbs cool down. Otherwise, there is the risk of sustaining a burn injury.

CAUTION

Replace any bulb only with a new bulb of the specified wattage. Using a bulb of different wattage could result in a fire. For the specified wattage of each bulb, refer to "Bulb chart" ^① 12-10.

■ Headlight

CAUTION

Halogen headlight bulbs become very hot while in use. If you touch the bulb surface with bare hands or greasy gloves, fingerprints or grease on the bulb surface will develop into hot spots, causing the bulb to break. If there are finger-

prints or grease on the bulb surface, wipe them away with a soft cloth moistened with alcohol.

NOTE

- If headlight aiming is required, consult your SUBARU dealer for proper adjustment of the headlight aim.
- It may be difficult to replace the bulbs. We recommend that you have the bulbs replaced by your SUBARU dealer if necessary.

▼ Low beam light bulbs

1. Pull off the fender lining. For details, refer to "Pulling off the fender lining" 11-7.

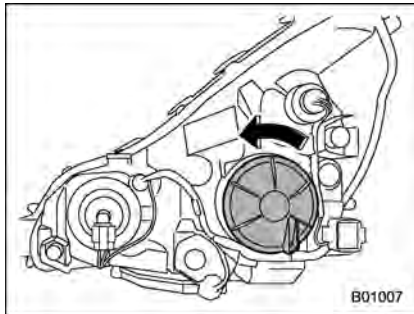

2. Remove the bulb cover, by turning it

counterclockwise.

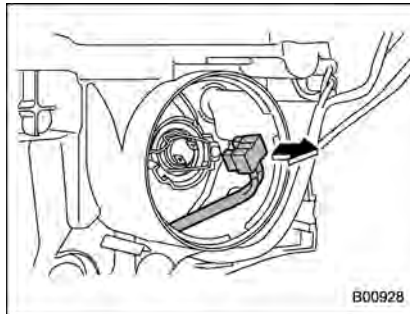

3. Disconnect the electrical connector.

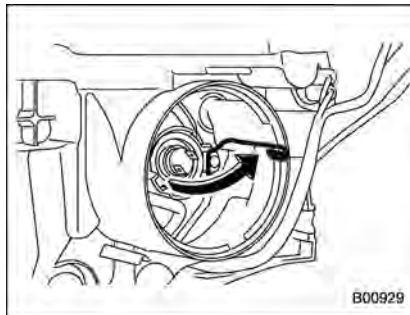

4. Remove the retainer spring.

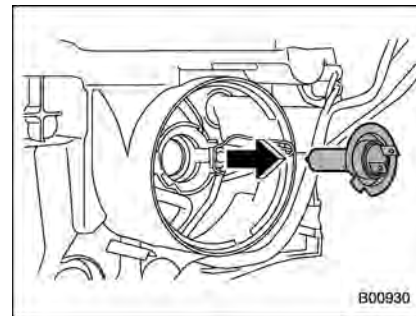

5. Replace the bulb, then set the retainer spring securely.
6. Reconnect the electrical connector.
7. Install the bulb cover.

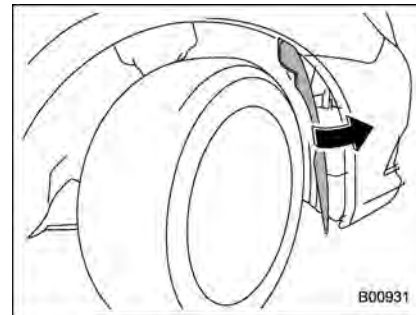

8. After replacing the bulb, reattach the fender lining.

– CONTINUED –

▼ **High beam light bulbs**

1. Remove the air intake duct (right-hand side). For the method to remove the air intake duct, refer to "Removing air intake duct" 11-7.

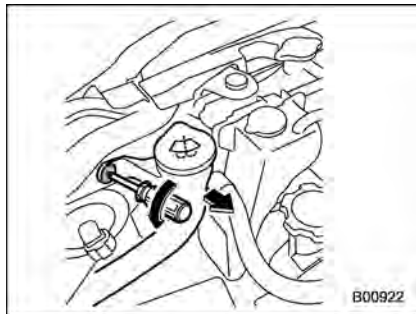

Left-hand side

2. Use a screwdriver to remove the secured clip of the washer tank. To make it easy to access the bulb, move the washer tank to the horizontal direction (left-hand side).

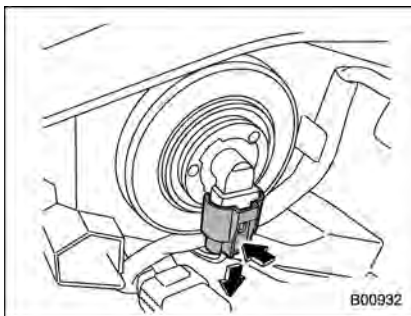

3. Disconnect the electrical connector from the bulb.

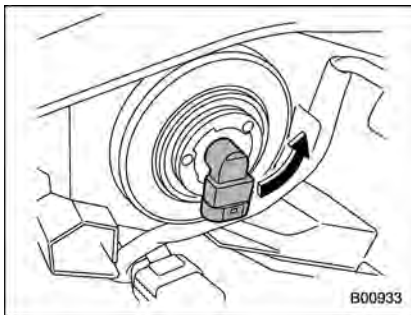

4. Remove the bulb from the headlight assembly by turning it counterclockwise.

5. Replace the bulb with new one. At this time, use care not to touch the bulb

surface.

6. Reconnect the electrical connector.

7. To install the bulb to the headlight assembly, turn it clockwise until it clicks.

8. Install the air intake duct with clips (right-hand side).

9. Set the washer tank to the original place and secure it by clip (left-hand side).

■ Front turn signal light

NOTE

It may be difficult to replace the bulbs. We recommend that you have the bulbs replaced by your SUBARU dealer if necessary.

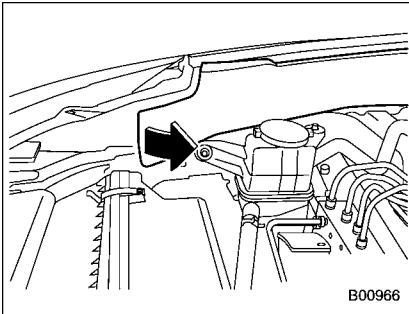

1. Turn over the protective cover of the engine compartment.

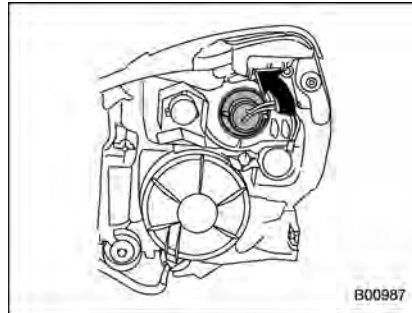

2. Turn the socket counterclockwise and pull it out.
3. Pull out the bulb from the socket and replace the bulb with a new one.

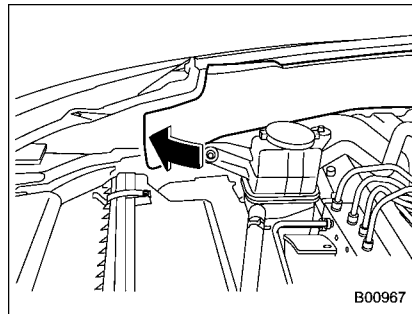

4. After replacing the bulbs, reposition the protective cover of the engine com-

partment.

■ Front position light

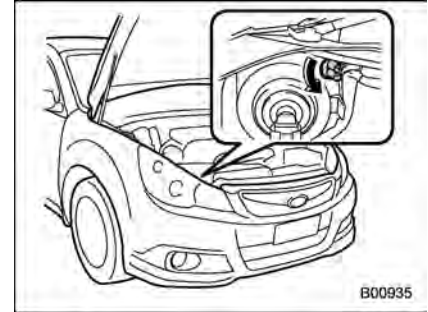

1. Turn the socket counterclockwise and pull it out.
2. Pull out the bulb from the socket and replace the bulb with a new one.

■ Front fog light (if equipped)

NOTE

It may be difficult to replace the bulbs. We recommend that you have the bulbs replaced by your SUBARU dealer if necessary.

1. Pull off the fender lining. Refer to "Pulling off the fender lining" 11-7.

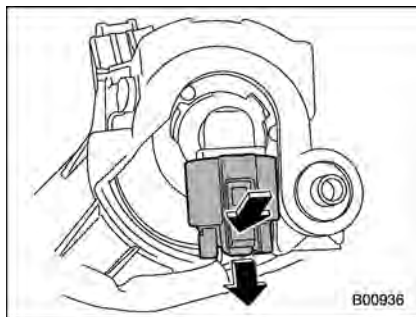

2. Disconnect the electrical connector.

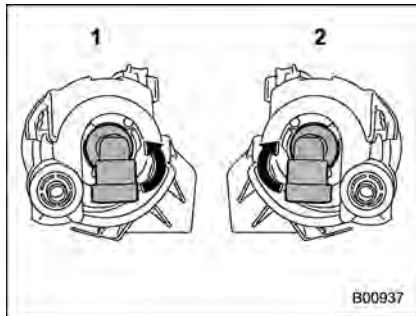

- 1) For left-hand side
- 2) For right-hand side

3. Turn the socket clockwise (right-hand side) or counterclockwise (left-hand side).

4. Pull out the socket.
5. Pull out the bulb from the socket and replace the bulb with a new one.

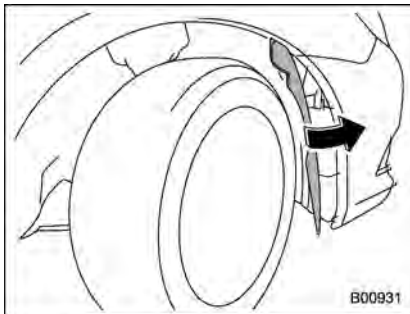

6. After replacing the bulb, reattach the fender lining.

■ Rear combination lights

▼ Legacy

NOTE

It may be difficult to replace the bulbs. We recommend that you have the bulbs replaced by your SUBARU dealer if necessary.

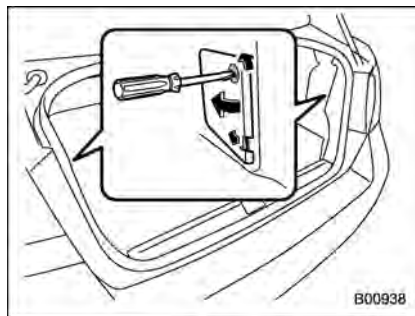

1. Turn the knobs of the cover 90 degrees counterclockwise to remove the cover.

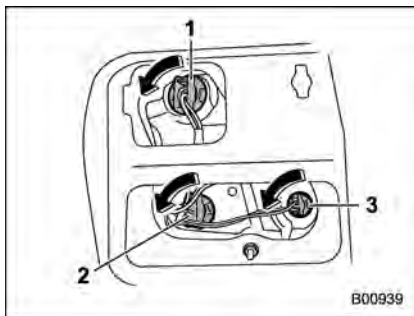

- 1) Brake/tail and rear side marker light
- 2) Rear turn signal light
- 3) Back-up light

2. Remove the bulb holder from the rear combination light assembly by turning it counterclockwise. Use pliers if necessary.
3. Pull the bulb out of the bulb holder and replace it with a new one.
4. Set the bulb holder into the rear combination light assembly and turn it clockwise until it locks.
5. Securely lock the cover against the trunk trim.

▼ Outback

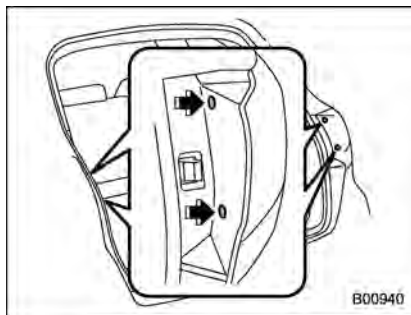

1. Undo the clips. For the method to undo the clips, refer to "Type C clips" ¶ 11-6.
2. Remove the cover.

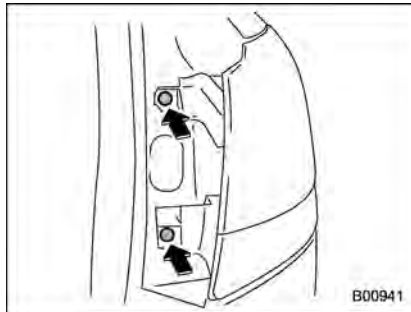

3. Remove the upper and lower screws.

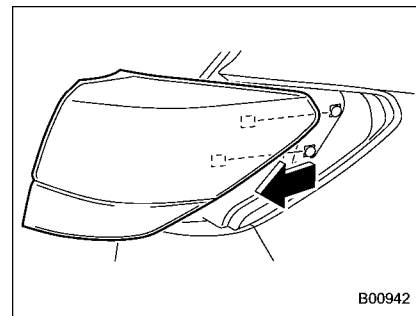

4. Slide the rear combination light assembly straight rearward and remove it from the vehicle.

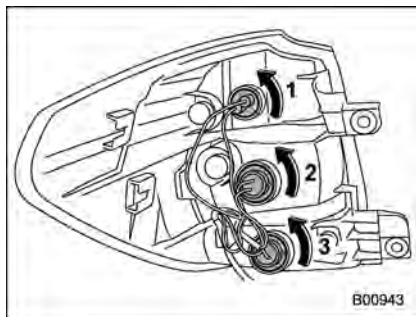

- 1) Tail and rear side marker light
- 2) Brake light
- 3) Rear turn signal light

5. Remove the bulb holder from the rear combination light assembly by turning it counterclockwise.
6. Pull the bulb out of the bulb holder and replace it with a new one.
7. Set the bulb holder into the rear combination light assembly and turn it clockwise until it locks.

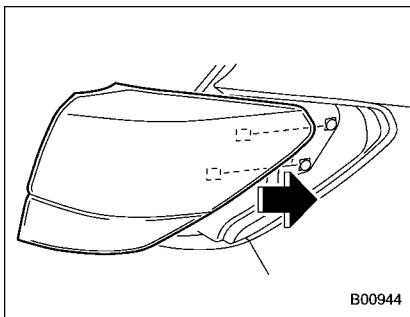

8. Reinstall the rear combination light assembly by sliding the two-pronged part of the combination light assembly securely to each holder of the vehicle side.

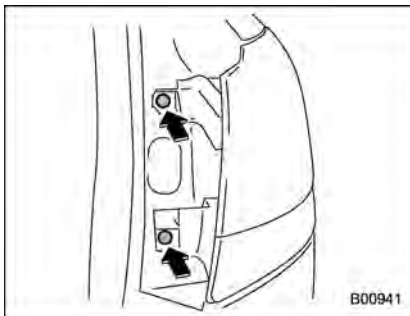

9. Tighten the upper and lower screws.
10. Reinstall the side cover.

■ Tail/Back-up light (Outback)

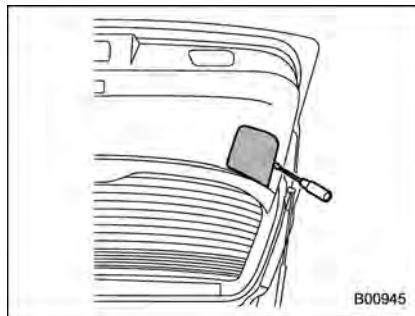

1. Apply a flat-head screwdriver to the light cover as shown in the illustration, and pry the light cover off from the rear gate trim.

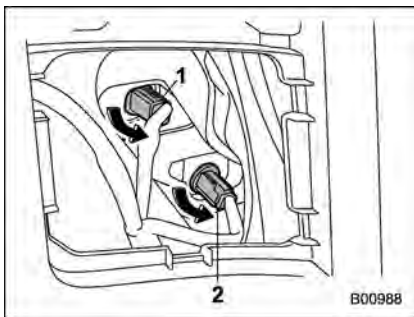

- 1) Back-up light
- 2) Tail light

2. Turn the bulb socket counterclockwise and remove it.

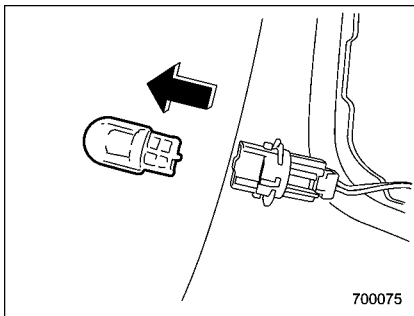

3. Pull the bulb out of the bulb socket and replace it with a new one.

4. Install the bulb socket by turning it clockwise.
5. Install the light cover on the rear gate.

■ License plate light

▼ Legacy

NOTE

It may be difficult to replace the bulbs. We recommend that you have the bulbs replaced by your SUBARU dealer if necessary.

1. Open the trunk.

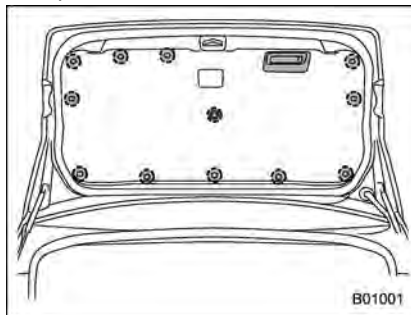

2. Remove the trunk trim lining by removing the 12 clips and the trunk trim handle.

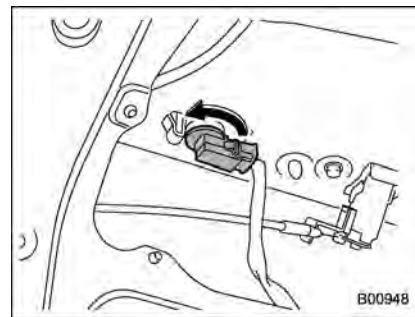

3. Turn the bulb socket counterclockwise and remove it.
4. Pull the bulb out of the bulb socket and replace it with a new one.
5. Install the bulb socket by turning it clockwise.
6. Reinstall the trunk trim lining.

▼ **Outback**

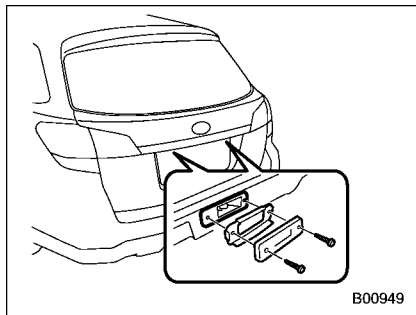

1. Remove the mounting screws using a Phillips screwdriver.
2. Remove the lens.

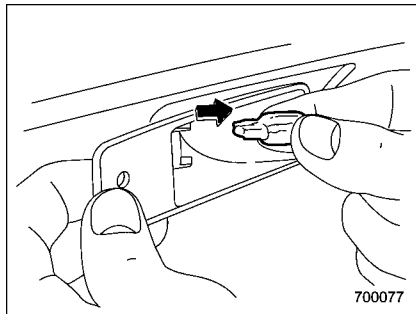

3. Pull the bulb out of the socket.

4. Install a new bulb.
5. Reinstall the lens.
6. Tighten the mounting screws.

■ **Dome light**

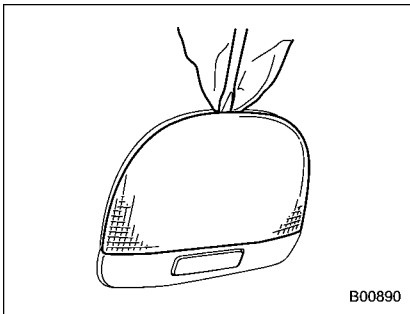

1. Remove the lens by prying the edge of the lens with a flat-head screwdriver.

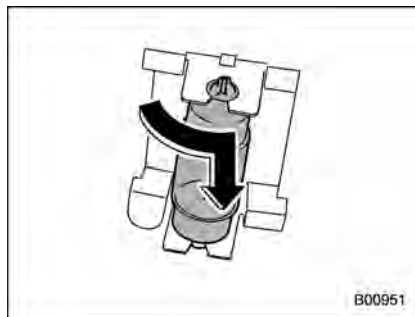

2. Turn the bulb until the flat surfaces at its ends are aligned vertically.
3. Pull the bulb straight downward to remove it.
4. Install a new bulb.
5. Reinstall the lens.

■ Map light

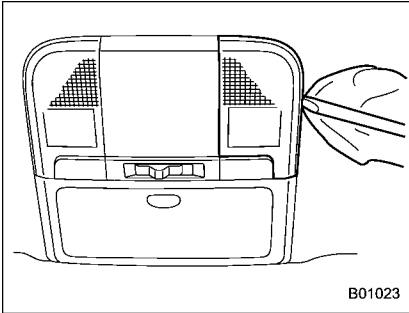

1. Remove the lens by prying the edge of the lens with a flat-head screwdriver.

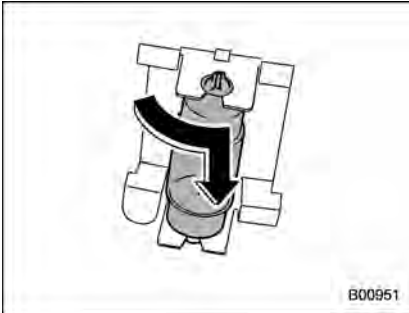

2. Turn the bulb until the flat surfaces at its ends are aligned vertically. Pull the bulb

straight downward to remove it.

3. Install a new bulb.
4. Reinstall the lens.

■ Vanity mirror light

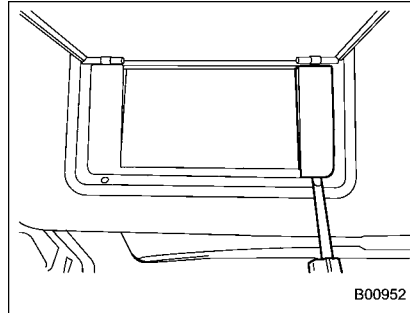

1. Remove the lens by prying the edge of the lens with a flat-head screwdriver.

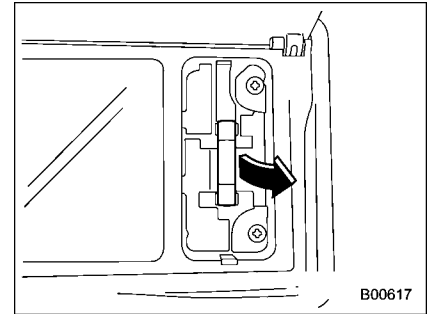

2. Pull the bulb out of the socket.
3. Install a new bulb.
4. Reinstall the lens.

■ Door step light

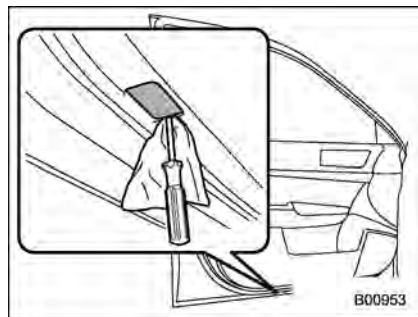

1. Remove the lens by prying the edge of the lens with a flat-head screwdriver.

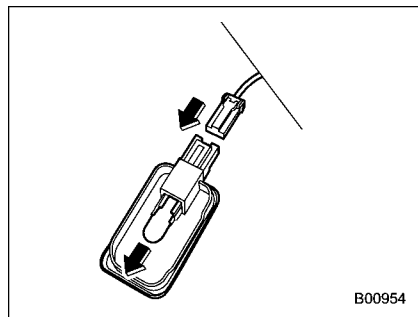

2. Pull the bulb out of the socket.
3. Install a new bulb.

4. Reinstall the lens.

■ Cargo area light (Outback)

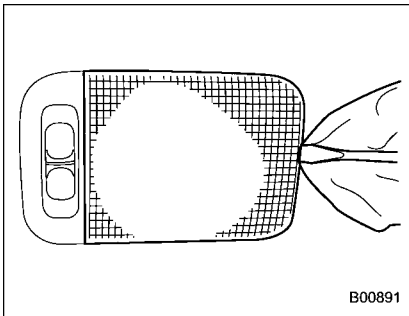

1. Remove the lens by prying the edge of the lens with a flat-head screwdriver.

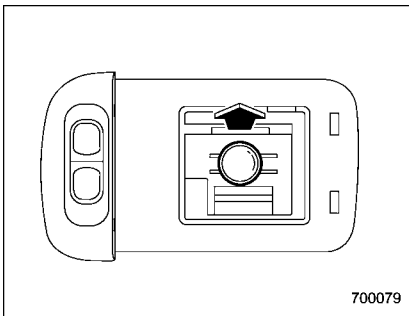

2. Pull the bulb out of the socket.
3. Install a new bulb.
4. Reinstall the lens.

■ Trunk light (Legacy)

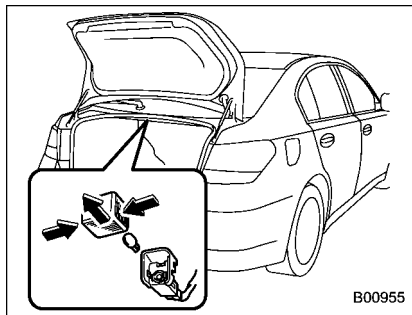

1. Push both sides of the light cover, and then remove the cover by pulling it out.
2. Pull the bulb out of the socket.
3. Install a new bulb.
4. Reinstall the cover.

■ Other bulbs

Other bulbs may be difficult to replace. We recommend that you have the bulbs replaced by your SUBARU dealer if necessary.

| | | | |
|--------------------------------|-------------|--|--------------|
| Specifications | 12-2 | Fuses and circuits | 12-6 |
| Dimensions | 12-2 | Fuse panel located in the passenger compartment | 12-6 |
| Engine | 12-3 | Fuse panel located in the engine compartment | 12-8 |
| Electrical system | 12-3 | Bulb chart | 12-10 |
| Capacities | 12-4 | Vehicle identification | 12-13 |
| Tires | 12-5 | | |
| Wheel alignment | 12-5 | | |

Specifications

These specifications are subject to change without notice.

■ Dimensions

in (mm)

| Item | Legacy | | | Outback | | | |
|---------------------------------|-----------------|--------------|--------------|--|--------------|-----|----|
| | 2.5 L non-turbo | 2.5 L turbo | 3.6 L | 2.5 L non-turbo | 3.6 L | | |
| Drive system | AWD | | | | | | |
| Transmission type | MT | CVT | MT | AT | MT | CVT | AT |
| Overall length | 186.4 (4,735) | | | 188.2 (4,780) | | | |
| Overall width | 71.7 (1,820) | | | 71.7 (1,820) | | | |
| Overall height | 59.3 (1,505) | | | 66.1 (1,680) ^{*2} 65.7 (1,670) ^{*3} | | | |
| Wheelbase | 108.3 (2,750) | | | 107.9 (2,740) | | | |
| Tread | Front | 61.6 (1,565) | 61.0 (1,550) | 61.6 (1,565) | 61.0 (1,550) | | |
| | Rear | 61.8 (1,570) | 61.2 (1,555) | 61.8 (1,570) | 61.0 (1,550) | | |
| Ground clearance ^{**1} | 5.9 (150) | | | 8.7 (220) | | | |

*1: Measured with vehicle empty

*2: Measured when roof rails are used as crossbars

*3: Measured when roof rails are not used as crossbars

AT: Automatic transmission

MT: Manual transmission

CVT: Continuously variable transmission

AWD: All-Wheel Drive

■ Engine

| Engine model | EJ253 (2.5 L, SOHC, non-turbo) | EJ255 (2.5 L, DOHC, turbo) | EZ36D (3.6 L, DOHC, non-turbo) |
|-------------------------|---|-------------------------------|---|
| Engine type | Horizontally opposed, liquid cooled 4 cylinder, 4 stroke gasoline engine | | Horizontally opposed, liquid cooled 6 cylinder, 4 stroke gasoline engine |
| Displacement cu-in (cc) | 150 (2,457) | | 222 (3,630) |
| Bore × Stroke in (mm) | 3.92 × 3.11 (99.5 × 79.0) | | 3.62 × 3.59 (92.0 × 91.0) |
| Compression ratio | 10.0 : 1 | 8.4 : 1 | 10.5 : 1 |
| Firing order | 1 – 3 – 2 – 4 | | 1 – 6 – 3 – 2 – 5 – 4 |

■ Electrical system

| | | |
|---------------------------------|------------------------|-------------------|
| Battery type and capacity (5HR) | | 75D23R (12V-52AH) |
| Alternator | 2.5 L models | 12V-110A |
| | 3.6 L models | 12V-130A |
| Spark plugs | 2.5 L non-turbo models | SIFR6A11 (NGK) |
| | 2.5 L turbo models | SILFR6B8 (NGK) |
| | 3.6 L models | SILFR6C11 (NGK) |

■ Capacities

| | | | |
|---|------------------------|-----|---------------------------------------|
| Fuel tank | | | 18.5 US gal (70 liters, 15.4 Imp gal) |
| Engine oil | 2.5 L models | | 4.2 US qt (4.0 liters, 3.5 Imp qt) |
| | 3.6 L models | | 6.7 US qt (6.3 liters, 5.5 Imp qt) |
| Transmission oil (MT) | | | 3.9 US qt (3.7 liters, 3.3 Imp qt) |
| Transmission fluid (CVT) | | | 13.2 US qt (12.5 liters, 11.0 Imp qt) |
| Transmission fluid (AT) | | | 10.4 US qt (9.8 liters, 8.6 Imp qt) |
| Front differential gear oil (AT and CVT models) | | | 1.5 US qt (1.4 liters, 1.2 Imp qt) |
| Rear differential gear oil | | | 0.8 US qt (0.8 liter, 0.7 Imp qt) |
| Power steering fluid | | | 0.7 US qt (0.7 liter, 0.6 Imp qt) |
| Engine coolant | 2.5 L non-turbo models | MT | 6.9 US qt (6.5 liters, 5.7 Imp qt) |
| | | CVT | 6.8 US qt (6.4 liters, 5.6 Imp qt) |
| | 2.5 L turbo models | | 6.9 US qt (6.5 liters, 5.7 Imp qt) |
| | 3.6 L models | | 6.9 US qt (6.5 liters, 5.7 Imp qt) |

■ **Tires**

| | | | | | | | |
|----------------------|----------|-----------------------------|-------------------|-------------------|-------------------|-------------------|------------------|
| Tire size | | P205/60R16 91V | P215/70R16 99S | P225/60R17 98T | P215/50R17 90V | P225/50R17 93V | 225/45R18 91W |
| Wheel size | | 16 × 6 1/2JJ 16 × 6 1/2J | 16 × 6 1/2JJ | 17 × 7J | 17 × 7 1/2J | | 18 × 7 1/2J |
| Pressure | Front | 33 psi (230 kPa) | 32 psi (220 kPa) | | 33 psi (230 kPa) | | |
| | Rear | 32 psi (220 kPa) | 30 psi (210 kPa) | | 32 psi (220 kPa) | | |
| Temporary spare tire | Size | T135/80R16 | T145/80R17 | | T135/70R17 | | |
| | Pressure | 60 psi (420 kPa) | | | | | |

■ **Wheel alignment**

| Item | | Legacy | | Outback |
|--------|-------|------------------------------------|-------------------------------|---|
| | | 2.5 L non-turbo models | Except 2.5 L non-turbo models | |
| Toe | Front | Toe in 0 in (0 mm) Total toe 0° | | Toe in 0.1 in (2 mm) Total toe 0°10' |
| | Rear | Toe in 0 in (0 mm) Total toe 0° | | Toe in 0.1 in (2 mm) Total toe 0°10' |
| Camber | Front | -0°30' | -0°15' | -0°00' |
| | Rear | -1°00' | -1°10' | -0°00' |

Fuses and circuits

■ Fuse panel located in the passenger compartment

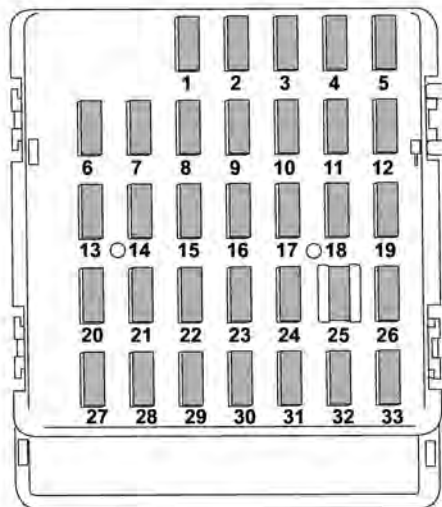

C00123

| Fuse panel | Fuse rating | Circuit |
|------------|-------------|---|
| 1 | 15A | ● Trailer hitch connector |
| 2 | 20A | ● Rear power window (left side) |
| 3 | 20A | ● Power window (driver's side) |
| 4 | 7.5A | ● Navigation system ● Front wiper deicer ● Moonroof |
| 5 | 7.5A | ● Combination meter |
| 6 | 7.5A | ● Remote control rear view mirrors |
| 7 | 7.5A | ● Integrated unit |
| 8 | 15A | ● Stop light |
| 9 | 15A | ● Seat heater relay |
| 10 | 7.5A | ● Power supply (battery) |
| 11 | 7.5A | ● Turn signal unit |
| 12 | 15A | ● Integrated unit ● Automatic transmission unit |

| Fuse panel | Fuse rating | Circuit |
|------------|-------------|--|
| 13 | 20A | ● Socket |
| 14 | Empty | |
| 15 | 20A | ● Rear power window (right side) |
| 16 | Empty | |
| 17 | 15A | ● Front wiper deicer |
| 18 | 7.5A | ● Back-up light |
| 19 | 7.5A | ● Electronic parking brake unit ● Hill Holder system unit |
| 20 | 10A | ● Accessory power outlet |
| 21 | 7.5A | ● Starter relay |
| 22 | 15A | ● Air conditioner |
| 23 | Empty | |
| 24 | 15A | ● Audio ● Navigation system |
| 25 | 15A | ● SRS airbag system |
| 26 | 7.5A | ● Main fan |
| 27 | 30A | ● Power window relay |

| Fuse panel | Fuse rating | Circuit |
|------------|-------------|---|
| 28 | Empty | |
| 29 | 20A | ● Power window (passenger's side) |
| 30 | Empty | |
| 31 | 7.5A | ● Automatic air conditioner unit |
| 32 | Empty | |
| 33 | 7.5A | ● ABS/Vehicle dynamics control unit ● Power steering |

■ Fuse panel located in the engine compartment

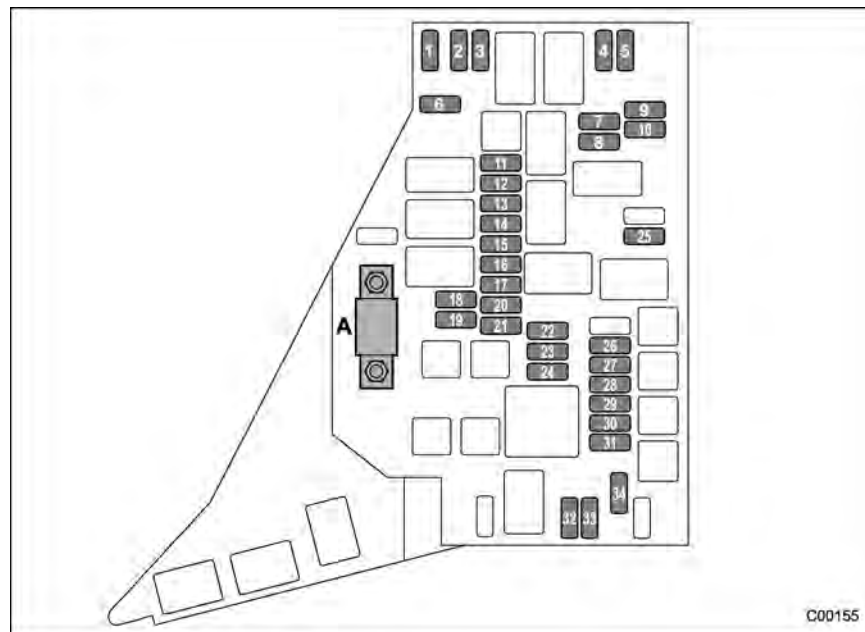

A) Main fuse

| Fuse panel | Fuse rating | Circuit |
|------------|-------------|---|
| 1 | 7.5A | ● CVT control unit |
| 2 | 7.5A | ● Horn LO |
| 3 | 7.5A | ● Horn HI |
| 4 | 15A | ● Low beam headlight (right side) |
| 5 | 15A | ● Low beam headlight (left side) |
| 6 | 20A | ● Fuel pump |
| 7 | 10A | ● High beam headlight (left side) |
| 8 | 10A | ● High beam headlight (right side) |
| 9 | 20A | ● Continuously variable transmission control unit |
| 10 | 7.5A | ● Alternator |
| 11 | 20A | ● Moonroof |
| 12 | 7.5A | ● Engine control unit |

C00155

| Fuse panel | Fuse rating | Circuit |
|------------|-------------|---|
| 13 | 15A | ● Engine control unit |
| 14 | 15A | ● Ignition coil |
| 15 | 15A | ● Engine control unit |
| 16 | 15A | ● Engine control unit |
| 17 | 15A | ● Automatic transmission control unit |
| 18 | 10A | ● Illumination |
| 19 | 10A | ● Rear combination light |
| 20 | 15A | ● Turn and hazard warning flasher (body control unit) |
| 21 | 20A | ● Door lock (body control unit) |
| 22 | 15A | ● Rear wiper ● Rear washer |
| 23 | 10A | ● Front washer |
| 24 | 30A | ● Front wiper |
| 25 | 25A | ● Rear window defogger ● Mirror heater ● Front wiper deicer |
| 26 | 15A | ● Blower fan |
| 27 | 15A | ● Blower fan |

| Fuse panel | Fuse rating | Circuit |
|------------|-------------|-------------------------------------|
| 28 | 25A | ● Audio unit |
| 29 | 25A | ● Sub fan |
| 30 | 25A | ● Main fan |
| 31 | 30A | ● ABS/Vehicle dynamics control unit |
| 32 | 10A | ● Fog light (right side) |
| 33 | 10A | ● Fog light (left side) |
| 34 | 10A | ● Back-up (body control unit) |

Bulb chart

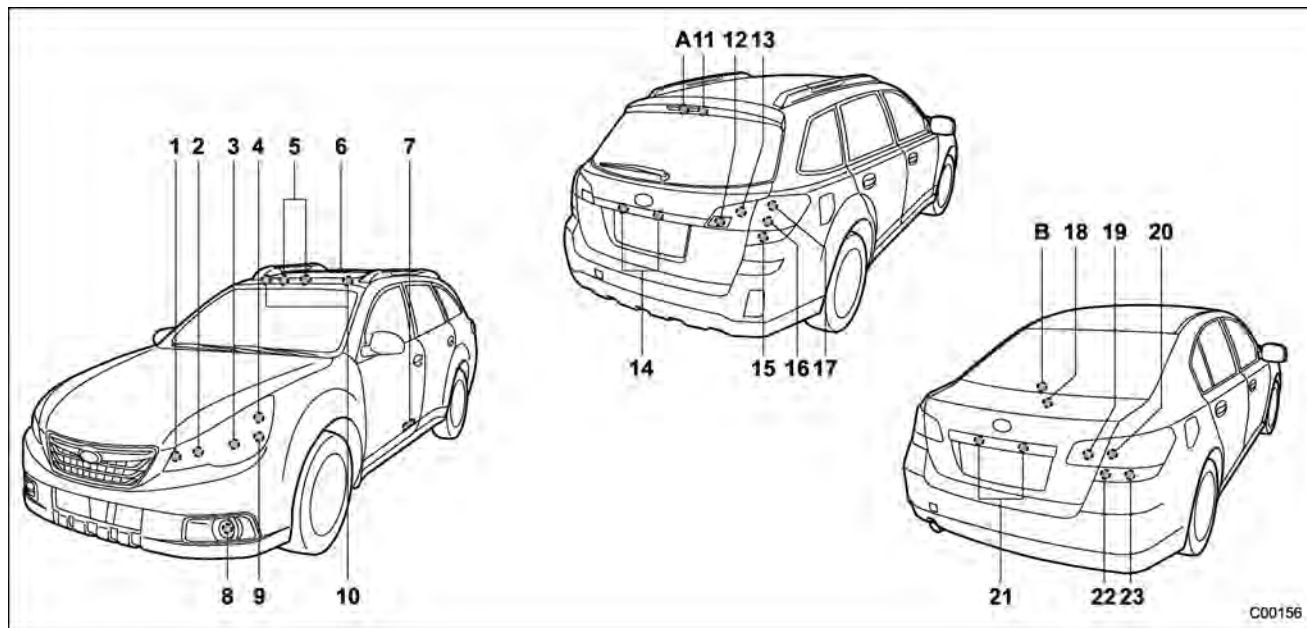

NOTE

Lights A and B are the LED (Light Emitting Diode) type. Consult your SUBARU dealer for replacement.

| | Wattage | Bulb No. |
|--------------------------------------|----------------|-----------------|
| 1) High beam headlight | 12V-60W | HB3 (9005) |
| 2) Front position light | 12V-5W | W5H |
| 3) Low beam headlight | 12V-55W | H7 |
| 4) Front turn signal light | 12V-21W | W21W |
| 5) Map light | 12V-8W | |
| 6) Dome light | 12V-8W | |
| 7) Door step light | 12V-5W | W5W |
| 8) Front fog light | 12V-55W | H11 |
| 9) Front side marker light | 12V-5W | W5W |
| 10) Vanity mirror light | 14V-1.4W | HTU |
| 11) Cargo area light | 12V-13W | |
| 12) Back-up light (Outback) | 12V-16W | W16W (921) |
| 13) Tail light (Outback) | 12V-5W | W5W |
| 14) Licence plate light (Outback) | 12V-5W | W5W |
| 15) Rear turn signal light (Outback) | 12V-21W | WY21W |

12-12 Specifications

| | Wattage | Bulb No. |
|--|----------------|-----------------|
| 16) Brake light (Outback) | 12V-21W | W21W |
| 17) Tail and rear side marker light (Outback) | 12V-5W | W5W |
| 18) Trunk light (Legacy) | 12V-5W | W5W |
| 19) Tail light (Legacy) | 12V-5W | W21/5W |
| 20) Brake/Tail and rear side marker light (Legacy) | 12V-21/5W | W21/5W |
| 21) License plate light (Legacy) | 12V-5W | W5W |
| 22) Back-up light (Legacy) | 12V-16W | 921 |
| 23) Rear turn signal light (Legacy) | 12V-21W | WY21W |
| A) High mount stop light (Outback) | — | — |
| B) High mount stop light (Legacy) | — | — |



WARNING

Bulbs may become very hot while illuminated. Before replacing bulbs, turn off the lights and wait until the bulbs cool down. Otherwise, there is the risk of sustaining a burn injury.



CAUTION

Replace any bulb only with a new bulb of the specified wattage. Using a bulb of different wattage could result in a fire.

Vehicle identification

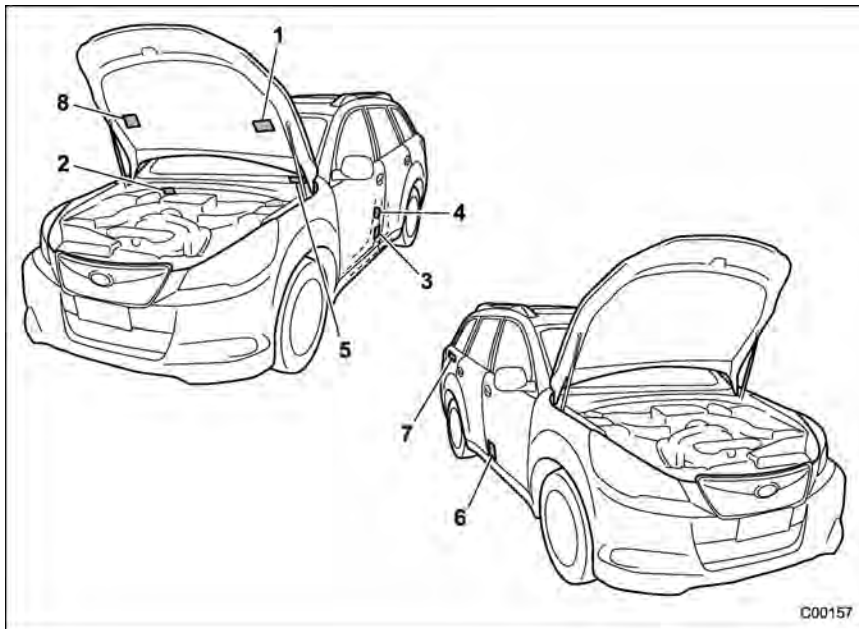

- 1) Emission control label
- 2) Vehicle identification number
- 3) Certification and bar code label
- 4) Tire inflation pressure label
- 5) Vehicle identification number plate
- 6) Model number label
- 7) Fuel label
- 8) Air conditioner label

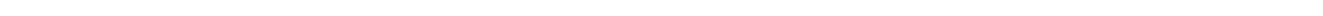
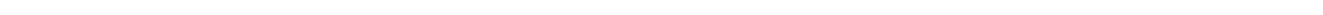
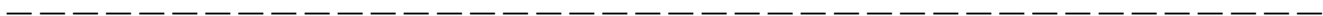
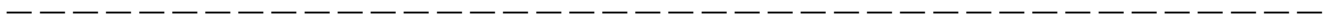

Consumer information and Reporting safety defects

| | | | |
|---|-------------|---|--------------|
| For U.S.A. | 13-2 | Determining compatibility of tire and vehicle load capacities | 13-14 |
| Tire information | 13-2 | Adverse safety consequences of overloading on handling and stopping and on tires | 13-14 |
| Tire labeling..... | 13-2 | Steps for Determining Correct Load Limit..... | 13-15 |
| Recommended tire inflation pressure..... | 13-5 | Uniform tire quality grading standards | 13-15 |
| Glossary of tire terminology | 13-7 | Treadwear | 13-16 |
| Tire care – maintenance and safety practices..... | 13-11 | Traction AA, A, B, C..... | 13-16 |
| Vehicle load limit – how to determine..... | 13-11 | Temperature A, B, C..... | 13-16 |
| | | Reporting safety defects (USA) | 13-17 |

For U.S.A.

The following information has been compiled according to Code of Federal Regulations "Title 49, Part 575".

Tire information

■ Tire labeling

Many markings (e.g. Tire size, Tire Identification Number or TIN) are placed on the sidewall of a tire by tire manufacturers. These markings can provide you with useful information on the tire.

▼ Tire size

Your vehicle comes equipped with P-Metric tire size. It is important to understand the sizing system in selecting the proper tire for your vehicles. Here is a brief review of the tire sizing system with a breakdown of its individual elements.

▽ P Metric

With the P-Metric system, Section Width is measured in millimeters. To convert millimeters into inches, divide by 25.4. The Aspect Ratio (Section Height divided by Section Width) helps provide more dimensional information about the tire size.

Example:

$$\frac{\mathbf{P}}{(1)} \quad \frac{\mathbf{205}}{(2)} \quad / \quad \frac{\mathbf{60}}{(3)} \quad \frac{\mathbf{R}}{(4)} \quad \frac{\mathbf{16}}{(5)}$$

- (1) P = Certain tire type used on light duty vehicles such as passenger cars
- (2) Section Width in millimeters
- (3) Aspect Ratio (= section height ÷ section width).
- (4) R = Radial Construction
- (5) Rim diameter in inches

▽ Load and Speed Rating Descriptions

The load and speed rating descriptions will appear following the size designation.

They provide two important facts about the tire. First, the number designation is its load index. Second, the letter designation indicates the tire's speed rating.

Example:

P 205 / 60 R 16 91 V
 Size designation (6) (7)

(6) Load Index: A numerical code which specifies the maximum load a tire can carry at the speed indicated by its speed symbol, at maximum inflation pressure.

For example, "91" means 1,356 lbs (615 kg), "90" means 1,323 lbs (600 kg), "89" means 1,279 lbs (580 kg)

WARNING

Load indices apply only to the tire, not to the vehicle. Putting a load rated tire on any vehicle does not mean the vehicle can be loaded up to the tire's rated load.

(7) Speed Rating: An alphabetical system describing a tire's capability to travel at established and predetermined speeds.

For example, "V" means 149 mph (240 km/h)

WARNING

- **Speed ratings apply only to the tire, not to the vehicle. Putting a speed rated tire on any vehicle does not mean the vehicle can be operated at the tire's rated speed.**
- **The speed rating is void if the tires are worn out, damaged, repaired, retreaded, or otherwise altered from their original condition. If tires are repaired, retreaded, or otherwise altered, they may not be suitable for original equipment tire designed loads and speeds.**

▼ Tire Identification Number (TIN)

Tire Identification Number (TIN) is marked on the intended outboard sidewall. The TIN is composed of four groups. Here is a brief review of the TIN with a breakdown of its individual elements.

DOT XX XX XXX XXXX

(1) (2) (3) (4)

(1) Manufacturer's Identification Mark

(2) Tire Size

(3) Tire Type Code

(4) Date of Manufacture

The first two figures identify the week, starting with "01" to represent the first full week of the calendar year; the second two figures represent the year. For example, 0101 means the 1st week of 2001.

▼ Other markings

The following markings are also placed on the sidewall.

▽ Maximum permissible inflation pressure

The maximum cold inflation pressure to which this tire may be inflated. For example, "350 kpa (51 PSI) MAX. PRESS"

▽ **Maximum load rating**

The load rating at the maximum permissible weight load for this tire. For example, "MAX. LOAD 615 kg (1,356 LBS) @ 350 kpa (51 PSI) MAX. PRESS."



WARNING

Maximum load rating applies only to the tire, not to the vehicle. Putting a load rated tire on any vehicle does not mean the vehicle can be loaded up to the tire's rated load.

▽ **Construction type**

Applicable construction of this tire. For example, "TUBELESS STEEL BELTED RADIAL"

▽ **Construction**

The generic name of each cord material used in the plies (both sidewall and tread area) of this tire. For example, "PLIES: TREAD 2

STEEL + 2 POLYESTER + 1 NYLON SIDEWALL 2 POLYESTER"

▽ **Uniform Tire Quality Grading (UTQG)**

For details, refer to "Uniform tire quality grading standards" 13-15.

■ Recommended tire inflation pressure

▼ Recommended cold tire inflation pressure

Recommended cold tire inflation pressure for your vehicle's tires is as follows.

| | | | | | | | |
|----------------------|----------|-----------------------------|-------------------|-------------------|-------------------|-------------------|------------------|
| Tire size | | P205/60R16 91V | P215/70R16 99S | P225/60R17 98T | P215/50R17 90V | P225/50R17 93V | 225/45R18 91W |
| Wheel size | | 16 × 6 1/2JJ 16 × 6 1/2J | 16 × 6 1/2JJ | 17 × 7J | 17 × 7 1/2J | | 18 × 7 1/2J |
| Pressure | Front | 33 psi (230 kPa) | 32 psi (220 kPa) | | 33 psi (230 kPa) | | |
| | Rear | 32 psi (220 kPa) | 30 psi (210 kPa) | | 32 psi (220 kPa) | | |
| Temporary spare tire | Size | T135/80R16 | T145/80R17 | | T135/70R17 | | |
| | Pressure | 60 psi (420 kPa) | | | | | |

▼ Vehicle placard

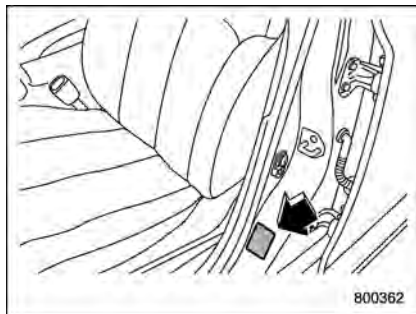

The vehicle placard is affixed to the driver's side B-pillar.

Example:

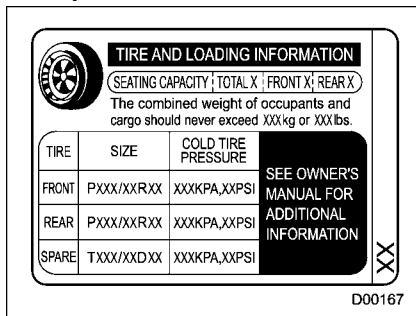

U.S.-spec. models

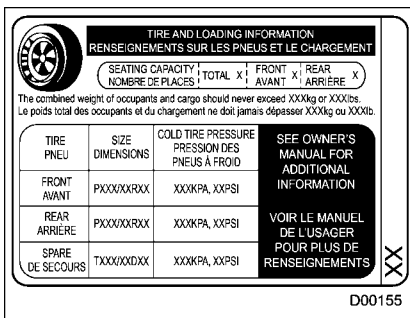

Canada-spec. models

The vehicle placard shows original tire size, recommended cold tire inflation pressure on each tire at maximum loaded vehicle weight, seating capacity and loading information.

▼ Adverse safety consequences of under-inflation

Driving at high speeds with excessively low tire pressures can cause the tires to flex severely and to rapidly become hot. A sharp increase in temperature could cause tread separation, and failure of the tire(s). Possible resulting loss of

vehicle control could lead to an accident.

▼ Measuring and adjusting air pressure to achieve proper inflation

Check and, if necessary, adjust the pressure of each tire (including the spare) at least once a month and before any long journey. Check the tire pressures when the tires are cold. Use a pressure gauge to adjust the tire pressures to the specific values. Driving even a short distance warms up the tires and increases the tire pressures. Also, the tire pressures are affected by the outside temperature. It is best to check tire pressure outdoors before driving the vehicle. When a tire becomes warm, the air inside it expands, causing the tire pressure to increase. Be careful not to mistakenly release air from a warm tire to reduce its pressure.

■ Glossary of tire terminology

● Accessory weight

The combined weight (in excess of those standard items which may be replaced) of automatic transmission, power steering, power brakes, power windows, power seats, radio, and heater, to the extent that these items are available as factory-installed equipment (whether installed or not).

● Bead

The part of the tire that is made of steel wires, wrapped or reinforced by ply cords and that is shaped to fit the rim.

● Bead separation

A breakdown of the bond between components in the bead.

● Bias ply tire

A pneumatic tire in which the ply cords that extend to the beads are laid at alternate angles substantially less than 90 degrees to the centerline of the tread.

● Carcass

The tire structure, except tread and

sidewall rubber which, when inflated, bears the load.

● Chunking

The breaking away of pieces of the tread or sidewall.

● Cold tire pressure

The pressure in a tire that has been driven less than 1 mile or has been standing for three hours or more.

● Cord

The strands forming the plies in the tire.

● Cord separation

The parting of cords from adjacent rubber compounds.

● Cracking

Any parting within the tread, sidewall, or inner liner of the tire extending to cord material.

● Curb weight

The weight of a motor vehicle with standard equipment including the maximum capacity of fuel, oil and coolant, and if so equipped, air conditioning and additional weight optional engine.

● Extra load tire

A tire designed to operate at higher loads and higher inflation pressure than the corresponding standard tire.

● Groove

The space between two adjacent tread ribs.

● Innerliner

The layer(s) forming the inside surface of a tubeless tire that contains the inflating medium within the tire.

● Innerliner separation

The parting of the innerliner from cord material in the carcass.

● Intended outboard sidewall

(1) The sidewall that contains a whitewall, bears white lettering or bears manufacturer, brand, and/or model name molding that is higher or deeper than the same molding on the other sidewall of the tire, or

(2) The outward facing sidewall of an asymmetrical tire that has a particular side that must always face outward when mount-

ing on a vehicle.

- **Light truck (LT) tire**

A tire designated by its manufacturer as primarily intended for use on lightweight trucks or multipurpose passenger vehicles.

- **Load rating**

The maximum load that a tire is rated to carry for a given inflation pressure.

- **Maximum inflation pressure**

The maximum cold inflation pressure to which a tire may be inflated.

- **Maximum load rating**

The load rating for a tire at the maximum permissible inflation pressure for that tire.

- **Maximum loaded vehicle weight**

The sum of:

- (a) Curb weight
- (b) Accessory weight
- (c) Vehicle capacity weight
- (d) Production options weight

- **Maximum permissible inflation pressure**

The maximum cold inflation pressure to which a tire may be inflated.

- **Measuring rim**

The rim on which a tire is fitted for physical dimension requirements.

- **Normal occupant weight**

150 lbs (68 kg) times the number of occupants specified in the second column of Table 1 that is appended to the end of this section.

- **Occupant distribution**

Distribution of occupants in a vehicle as specified in the third column of Table 1 that is appended to the end of this section.

- **Open splice**

Any parting at any junction of tread, sidewall, or innerliner that extends to cord material.

- **Outer diameter**

The overall diameter of an inflated new tire.

- **Overall width**

The linear distance between the exteriors of the sidewalls of an inflated tire, including elevations due to labeling, decorations, or protective bands or ribs.

- **Passenger car tire**

A tire intended for use on passenger cars, multipurpose passenger vehicles, and trucks, that have a gross vehicle weight rating (GVWR) of 10,000 lbs (4,535 kg) or less.

- **Ply**

A layer of rubber-coated parallel cords.

- **Ply separation**

A parting of rubber compound between adjacent plies.

- **Pneumatic tire**

A mechanical device made of rubber, chemicals, fabric and steel or other materials, that, when mounted on an automotive wheel, provides the traction and contains the gas or fluid that sustains the load.

- **Production options weight**

The combined weight of those installed regular production options weighing over 5.1 lbs (2.3 kg) in excess of those standard items which they replace, not previously considered in curb weight or acces-

sory weight, including heavy duty brakes, ride levelers, roof rack, heavy duty battery, and special trim.

- **Radial ply tire**

A pneumatic tire in which the ply cords that extend to the beads are laid at substantially 90 degrees to the centerline of the tread.

- **Recommended inflation pressure**

The cold inflation pressure recommended by a vehicle manufacturer.

- **Reinforced tire**

A tire designed to operate at higher loads and at higher inflation pressures than the corresponding standard tire.

- **Rim**

A metal support for a tire or a tire and tube assembly upon which the tire beads are seated.

- **Rim diameter**

Nominal diameter of the bead seat.

- **Rim size designation**

Rim diameter and width.

- **Rim type designation**

The industry of manufacturer's designation for a rim by style or code.

- **Rim width**

Nominal distance between rim flanges.

- **Section width**

The linear distance between the exteriors of the sidewalls of an inflated tire, excluding elevations due to labeling, decoration, or protective bands.

- **Sidewall**

That portion of a tire between the tread and bead.

- **Sidewall separation**

The parting of the rubber compound from the cord material in the sidewall.

- **Test rim**

The rim on which a tire is fitted for testing, and it may be any rim listed as appropriate for use with that tire.

- **Tread**

That portion of a tire that comes into contact with the road.

- **Tread rib**

A tread section running circumferentially around a tire.

- **Tread separation**

Pulling away of the tread from the tire carcass.

- **Treadwear indicators (TWI)**

The projections within the principal grooves designed to give a visual indication of the degrees of wear of the tread.

- **Vehicle capacity weight**

The rated cargo and luggage load plus 150 lbs (68 kg) times the vehicle's designated seating capacity.

- **Vehicle maximum load on the tire**

Load on an individual tire that is determined by distributing to each axle its share of the maximum loaded vehicle weight and dividing by two.

- **Vehicle normal load on the tire**

Load on an individual tire that is determined by distributing to each axle its share of the curb weight,

accessory weight, and normal occupant weight (distributed in accordance with Table 1 that is appended to the end of this section) and dividing by 2.

- **Wheel-holding fixture**

The fixture used to hold the wheel and tire assembly securely during testing.

Table 1 — Occupant loading and distribution for vehicle normal load for various designated seating capacities

| Designated seating capacity, number of occupants | Vehicle normal load, number of occupants | Occupant distribution in a normally loaded vehicle |
|--|--|--|
| 2 through 4 | 2 | 2 in front. |
| 5 through 10 | 3 | 2 in front, 1 in second seat. |
| 11 through 15 | 5 | 2 in front, 1 in second seat, 1 in third seat, 1 in fourth seat. |
| 16 through 22 | 7 | 2 in front, 2 in second seat, 2 in third seat, 1 in fourth seat. |

■ Tire care – maintenance and safety practices

- Check on a daily basis that the tires are free from serious damage, nails, and stones. At the same time, check the tires for abnormal wear.
- Inspect the tire tread regularly and replace the tires before their tread wear indicators become visible. When a tire's tread wear indicator becomes visible, the tire is worn beyond the acceptable limit and must be replaced immediately. With a tire in this condition, driving at even low speeds in wet weather can cause the vehicle to hydroplane. Possible resulting loss of vehicle control can lead to an accident.
- To maximize the life of each tire and ensure that the tires wear uniformly, it is best to rotate the tires every 7,500 miles (12,000 km). Rotating the tires involves switching the front and rear tires on the right-hand side of the vehicle and similarly switching the front and

rear tires on the left-hand side of the vehicle. (Each tire must be kept on its original side of the vehicle.) Replace any damaged or unevenly worn tire at the time of rotation. After tire rotation, adjust the tire pressures and make sure the wheel nuts are correctly tightened. For information about the tightening torque and tightening sequence for the wheel nuts, refer to "Flat tires" ¶9-6.

■ Vehicle load limit – how to determine

The load capacity of your vehicle is determined by weight, not by available cargo space. The load limit of your vehicle is shown on the vehicle placard attached to the driver's side B-pillar. Locate the statement "The combined weight of occupants and cargo should never exceed XXX kg or XXX lbs" on your vehicle's placard.

The vehicle placard also shows seating capacity of your vehicle.

The total load capacity includes the total weight of driver and all passengers and their belongings, any cargo, any optional equipment such as a trailer hitch, roof rack or bike carrier, etc., and the tongue load of a trailer. Therefore cargo capacity can be calculated by the following method.

Cargo capacity = Load limit – (total weight of occupants + total weight of optional equipment + tongue load of a trailer (if applicable))

For towing capacity information and weight limits, refer to "Trailer towing" ¶8-19.

▼ **Calculating total and load capacities varying seating configurations**

Calculate the available load capacity as shown in the following examples:

Example 1A

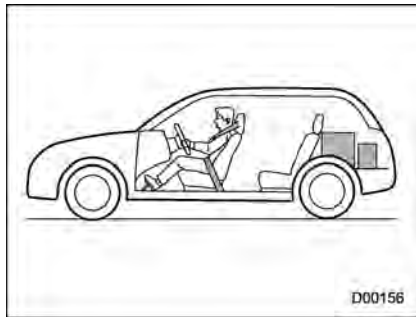

Vehicle capacity weight of the vehicle is 800 lbs (363 kg), which is indicated on the vehicle placard with the statement "The combined weight of occupants and cargo should never exceed 363 kg or 800 lbs".

For example, if the vehicle has one

occupant weighing 154 lbs (70 kg) plus cargo weighing 551 lbs (250 kg).

1. Calculate the total weight.

Total weight

$$= \frac{154 \text{ lbs (70 kg)}}{\text{(Occupant)}} + \frac{551 \text{ lbs (250 kg)}}{\text{(Cargo)}}$$

$$= \mathbf{705 \text{ lbs (320 kg)}}$$

2. Calculate the available load capacity by subtracting the total weight from the vehicle capacity weight of 800 lbs (363 kg).

Available Load Capacity

$$= \frac{800 \text{ lbs (363 kg)}}{\text{(Vehicle capacity weight)}} - \frac{705 \text{ lbs (320 kg)}}{\text{(Total weight)}}$$

$$= \mathbf{95 \text{ lbs (43 kg)}}$$

3. The result of step 2 shows that a further 95 lbs (43 kg) of cargo can be carried.

Example 1B

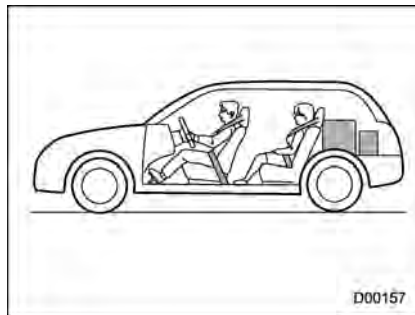

For example, if a person weighing 176 lbs (80 kg) now enters the same vehicle (bringing the number of occupants to two), the calculations are as follows:

1. Calculate the total weight.

Total weight

$$= \frac{154 \text{ lbs (70 kg)}}{\text{(Occupant)}} + \frac{176 \text{ lbs (80 kg)}}{\text{(Occupant)}}$$

$$+ \frac{551 \text{ lbs (250 kg)}}{\text{(Cargo)}}$$

$$= \mathbf{881 \text{ lbs (400 kg)}}$$

2. Calculate the available load capacity.

Available Load Capacity

$$= \frac{800 \text{ lbs (363 kg)}}{\text{(Vehicle capacity weight)}} - \frac{881 \text{ lbs (400 kg)}}{\text{(Total weight)}}$$

$$= -81 \text{ lbs (-37 kg)}$$

3. The total weight now exceeds the capacity weight by 81 lbs (37 kg), so the cargo weight must be reduced by 81 lbs (37 kg) or more.

Example 2A

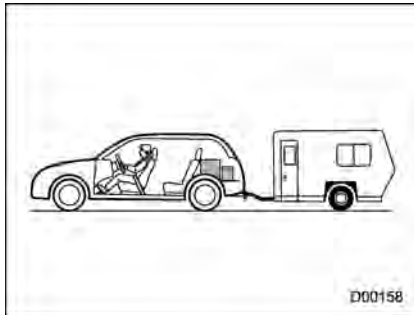

Vehicle capacity weight of the vehicle is 800 lbs (363 kg), which

is indicated on the vehicle placard with the statement "The combined weight of occupants and cargo should never exceed 363 kg or 800 lbs".

For example, the vehicle has one occupant weighing 165 lbs (75 kg) plus cargo weighing 265 lbs (120 kg). In addition, the vehicle is fitted with a trailer hitch weighing 22 lbs (10 kg), to which is attached a trailer weighing 1,764 lbs (800 kg). 10% of the trailer weight is applied to the trailer tongue (i.e. Tongue load = 176 lbs (80 kg)).

1. Calculate the total weight.

Total weight

$$= \frac{165 \text{ lbs (75 kg)}}{\text{(Occupant)}} + \frac{265 \text{ lbs (120 kg)}}{\text{(Cargo)}}$$

$$+ \frac{22 \text{ lbs (10 kg)}}{\text{(Trailer hitch)}} + \frac{176 \text{ lbs (80 kg)}}{\text{(Tongue load)}}$$

$$= 628 \text{ lbs (285 kg)}$$

2. Calculate the available load capacity.

Available Load Capacity

$$= \frac{800 \text{ lbs (363 kg)}}{\text{(Vehicle capacity weight)}} - \frac{628 \text{ lbs (285 kg)}}{\text{(Total weight)}}$$

$$= 172 \text{ lbs (78 kg)}$$

3. The result of step 2 shows that a further 172 lbs (78 kg) of cargo can be carried.

Example 2B

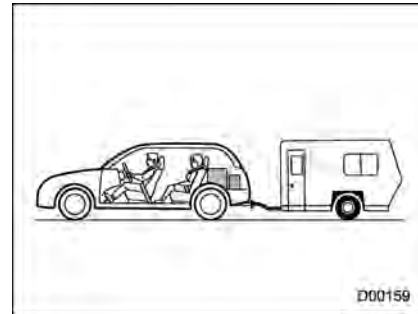

For example, if a person weighing 143 lbs (65 kg) and a child weighing 40 lbs (18 kg) now enter the same

vehicle (bringing the number of occupants to three), and a child restraint system weighing 11 lbs (5 kg) is installed in the vehicle for the child to use, the calculations are as follows:

1. Calculate the total weight.

Total weight

$$\begin{aligned}
 &= \frac{165 \text{ lbs (75 kg)} + 143 \text{ lbs (65 kg)}}{\text{(Occupant)}} \\
 &+ \frac{40 \text{ lbs (18 kg)}}{\text{(Occupant)}} \\
 &+ \frac{11 \text{ lbs (5 kg)}}{\text{(Child restraint)}} + \frac{265 \text{ lbs (120 kg)}}{\text{(Cargo)}} \\
 &+ \frac{22 \text{ lbs (10 kg)}}{\text{(Trailer hitch)}} + \frac{176 \text{ lbs (80 kg)}}{\text{(Tongue load)}} \\
 &= \mathbf{822 \text{ lbs (373 kg)}}
 \end{aligned}$$

2. Calculate the available load capacity.

Available Load Capacity

$$\begin{aligned}
 &= \frac{800 \text{ lbs (363 kg)}}{\text{(Vehicle capacity weight)}} - \frac{822 \text{ lbs (373 kg)}}{\text{(Total weight)}} \\
 &= \mathbf{-22 \text{ lbs (-10 kg)}}
 \end{aligned}$$

3. The total weight now exceeds the capacity weight by 22 lbs (10 kg), so the cargo weight must be reduced by 22 lbs (10 kg) or more.

■ **Determining compatibility of tire and vehicle load capacities**

The sum of four tires' maximum load ratings must exceed the maximum loaded vehicle weight ("GVWR"). In addition, sum of the maximum load ratings of two front tires and of two rear tires must exceed each axle's maximum loaded capacity ("GAWR"). Original equipment tires are designed to fulfill those conditions.

The maximum loaded vehicle weight is referred to Gross Vehicle Weight Rating (GVWR). And each

axle's maximum loaded capacity is referred to Gross Axle Weight Rating (GAWR). The GVWR and each axle's GAWR are shown on the vehicle certification label affixed to the driver's door.

The GVWR and front and rear GAWRs are determined by not only the maximum load rating of tires but also loaded capacities of the vehicle's suspension, axles and other parts of the body.

Therefore, this means that the vehicle cannot necessarily be loaded up to the tire's maximum load rating on the tire sidewall.

■ **Adverse safety consequences of overloading on handling and stopping and on tires**

Overloading could affect vehicle handling, stopping distance, vehicle and tire as shown in the following. This could lead to an accident and possibly result in severe personal injury.

- Vehicle stability will deteriorate.
- Heavy and/or high-mounted loads could increase the risk of rollover.
- Stopping distance will increase.
- Brakes could overheat and fail.
- Suspension, bearings, axles and other parts of the body could break or experience accelerated wear that will shorten vehicle life.
- Tires could fail.
- Tread separation could occur.
- Tire could separate from its rim.

■ Steps for Determining Correct Load Limit

1. Locate the statement "The combined weight of occupants and cargo should never exceed XXX pounds" on your vehicle's placard.
2. Determine the combined weight of the driver and passengers that will be riding in your vehicle.
3. Subtract the combined weight of the driver and passengers from XXX kilograms or XXX pounds.
4. The resulting figure equals the

available amount of cargo and luggage load capacity. For example, if the "XXX" amount equals 1,400 lbs (635 kg) and there will be five- 150 lbs (68 kg) passengers in your vehicle, the amount of available cargo and luggage load capacity is 650 lbs (1,400 - 750 (5 × 150) = 650 lbs).

5. Determine the combined weight of luggage and cargo being loaded on the vehicle. That weight may not safely exceed the available cargo and luggage load capacity calculated in Step 4.

6. If your vehicle will be towing a trailer, load from your trailer will be transferred to your vehicle. Consult this manual to determine how this reduces the available cargo and luggage load capacity of your vehicle.

Uniform tire quality grading standards

This information indicates the relative performance of passenger car tires in the area of treadwear, traction, and temperature resistance. This is to aid the consumer in making an informed choice in the purchase of tires.

Quality grades can be found where applicable on the tire sidewall between tread shoulder and maximum section width. For example:

Treadwear 200 Traction AA Temperature A

The quality grades apply to new pneumatic tires for use on passenger cars. However, they do not apply to deep tread, winter type snow tires, space-saver or temporary use spare tires, tires with nominal rim diameters of 12 inches or less, or to some limited production tires.

All passenger car tires must con-

form to Federal Safety Requirements in addition to these grades.

■ Treadwear

The treadwear grade is a comparative rating based on the wear rate of the tire when tested under controlled conditions on a specified government test course.

For example, a tire graded 150 would wear one and one-half (1-1/2) times as well on the government course as a tire graded 100. The relative performance of tires depends upon the actual conditions of their use, however, and may depart significantly from the norm due to variations in driving habits, service practices and differences in road characteristics and climate.

■ Traction AA, A, B, C

The traction grades, from highest to lowest, are AA, A, B and C. Those grades represent the tire's ability to stop on wet pavement as measured under controlled conditions on spe-

cified government test surfaces of asphalt and concrete. A tire marked C may have poor traction performance.

WARNING

The traction grade assigned to this tire is based on straight-ahead braking traction tests, and does not include acceleration, cornering, hydroplaning, or peak traction characteristics.

■ Temperature A, B, C

The temperature grades are A (the highest), B, and C, representing the tire's resistance to the generation of heat and its ability to dissipate heat when tested under controlled conditions on a specified indoor laboratory test wheel. Sustained high temperature can cause the material of the tire to degenerate and reduce tire life, and excessive temperature can lead to sudden tire failure. The

grade C corresponds to a level of performance which all passenger car tires must meet under the Federal Motor Vehicle Safety Standards No. 109. Grades B and A represent higher levels of performance on the laboratory test wheel than the minimum required by law.

WARNING

The temperature grade for this tire is established for a tire that is properly inflated and not overloaded. Excessive speed, underinflation, or excessive loading, either separately or in combination, can cause heat buildup and possible tire failure.

Reporting safety defects (USA)

If you believe that your vehicle has a defect which could cause a crash or could cause injury or death, you should immediately inform the National Highway Traffic Safety Administration (NHTSA) in addition to notifying Subaru of America, Inc.

If NHTSA receives similar complaints, it may open an investigation, and if it finds that a safety defect exists in a group of vehicles, it may order a recall and remedy campaign. However, NHTSA cannot become involved in individual problems between you, your dealer, or Subaru of America, Inc. To contact NHTSA, you may call the Vehicle Safety Hotline toll-free at 1-888-327-4236 (TTY: 1-800-424-9153); go to <http://www.safercar.gov>; or write to: Administrator, NHTSA, 400 Seventh Street, SW., Washington,

DC 20590. You can also obtain other information about motor vehicle safety from <http://www.safercar.gov>.

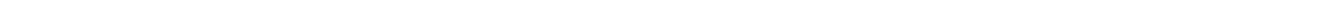
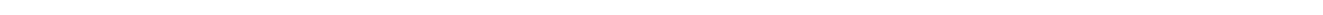
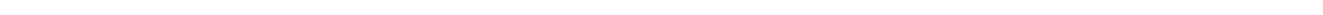
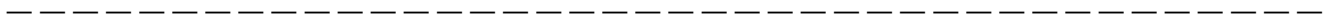

A

| | |
|--|------------|
| ABS (Anti-lock Brake System) | 7-25 |
| Warning light | 3-16, 7-25 |
| Accessories | 5-4, 11-50 |
| Accessory power outlet | 6-10 |
| Air cleaner element | 11-20 |
| Air conditioner | |
| Automatic climate control system | 4-12 |
| Manual climate control system | 4-7 |
| Air filtration system | 4-15 |
| Air flow selection | 4-2 |
| Automatic climate control system | 4-12 |
| Manual climate control system | 4-5 |
| Alarm system | 2-16 |
| All-Wheel Drive warning light | 3-20 |
| Aluminum wheel | 11-42 |
| Cleaning | 10-3 |
| Antenna system | 5-2 |
| Anti-lock Brake System (ABS) | 7-25 |
| Arming the system | 2-17 |
| Armrest | 1-12 |
| Ashtray | 6-12 |
| AT OIL TEMP warning light | 3-15 |
| Audio | |
| Antenna system | 5-2 |
| AUX unit operation | 5-28 |
| CD player operation | 5-18 |
| Control button | 5-30 |
| FM/AM radio operation | 5-10 |
| Power and sound controls | 5-7 |
| Satellite radio operations | 5-14 |

| | |
|---|-------|
| Set | 5-4 |
| XM™ satellite radio reception | 5-2 |
| Auto on/off headlights | 3-27 |
| Sensor | 3-28 |
| Auto-dimming mirror/compass | 3-36 |
| Automatic climate control system | 4-8 |
| Automatic transmission | 7-18 |
| Capacities | 12-4 |
| Fluid | 11-24 |
| Manual mode | 7-21 |
| Oil temperature warning light (AT OIL TEMP) | 3-15 |
| Select lever | 7-19 |
| Shift lock function | 7-20 |
| Automatic/Emergency Locking Retractor (A/ELR) | 1-13 |
| AUX unit operation | 5-28 |

B

| | |
|---|-------------|
| Battery | 11-47 |
| Drainage prevention function | 2-6 |
| Jump starting | 9-10 |
| Replacement (remote engine start transmitter) | 7-14 |
| Replacement (remote keyless entry system) | 2-11 |
| Booster seat | 1-31 |
| Bottle holder | 6-9 |
| Brake | |
| Assist | 7-24 |
| Booster | 7-24, 11-32 |
| Fluid | 11-30 |
| Pad and lining | 11-34 |
| Parking | 7-34 |
| Pedal | 11-33 |

| | |
|---|-------|
| System | 7-24 |
| Brake pedal | |
| Free play | 11-33 |
| Reserve distance | 11-33 |
| Brake system | 7-24 |
| Warning light | 3-17 |
| Braking | 7-23 |
| Tips | 7-23 |
| Breaking-in of new brake pads and linings | 11-34 |
| Bulb | |
| Chart | 12-10 |
| Replacing | 11-50 |
| C | |
| Capacities | 12-4 |
| Cargo area | |
| Cover | 6-15 |
| Light | 6-3 |
| Tie-down hooks | 6-17 |
| Catalytic converter | 8-3 |
| Center | |
| Console | 6-6 |
| Ventilators | 4-3 |
| Changing | |
| Coolant | 11-18 |
| Flat tire | 9-6 |
| Oil and oil filter | 11-14 |
| Charge warning light | 3-14 |
| CHECK ENGINE warning light/Malfunction indicator lamp | 3-12 |

| | |
|--|------------|
| Checking | |
| Brake pedal free play | 11-33 |
| Brake pedal reserve distance | 11-33 |
| Clutch function | 11-33 |
| Clutch pedal free play | 11-34 |
| Coolant level | 11-18 |
| Fluid level (automatic transmission fluid) | 11-24 |
| Fluid level (brake fluid) | 11-30 |
| Fluid level (clutch fluid) | 11-31 |
| Fluid level (power steering fluid) | 11-29 |
| Fluid level (washer fluid) | 11-42 |
| Oil level (engine oil) | 11-12 |
| Oil level (front differential gear oil) | 11-26 |
| Oil level (manual transmission oil) | 11-23 |
| Oil level (rear differential gear oil) | 11-27 |
| Child restraint systems | 1-25 |
| Installation of a booster seat | 1-31 |
| Installation with A/ELR seatbelt | 1-28 |
| Lower and tether anchorages | 1-33 |
| Top tether anchorages | 1-35 |
| Child safety | 5 |
| Locks | 2-20 |
| Chime | |
| Key | 3-4 |
| Light | 3-27 |
| Seatbelt | 1-14, 3-10 |
| Cleaning | |
| Aluminum wheels | 10-3 |
| Interior | 10-5 |
| Ventilation grille | 4-14 |

- | | | |
|--|----------------------|--|
| Climate control system | | |
| Automatic..... | 4-8 | |
| Manual..... | 4-4 | |
| Clock..... | 3-24 | |
| Clutch | | |
| Fluid..... | 11-31 | |
| Pedal..... | 11-33 | |
| Coat hook..... | 6-13 | |
| Continuously variable transmission..... | 7-18 | |
| Capacities..... | 12-4 | |
| Fluid..... | 11-26 | |
| Manual mode..... | 7-21 | |
| Oil temperature warning light (AT OIL TEMP)..... | 3-15 | |
| Select lever..... | 7-19 | |
| Shift lock function..... | 7-20 | |
| Coolant..... | 11-18 | |
| Temperature high warning light..... | 3-13 | |
| Temperature low indicator light..... | 3-13 | |
| Cooling system..... | 11-17 | |
| Corrosion protection..... | 10-4 | |
| Crossbars..... | 8-14 | |
| Cruise control..... | 7-38 | |
| Indicator light..... | 3-23, 7-41 | |
| Set indicator light..... | 3-23, 7-41 | |
| Cup holder..... | 6-8 | |
| Front passenger's..... | 6-9 | |
| Rear passenger's..... | 6-9 | |
| D | | |
| Daytime running light system..... | 3-29 | |
| Defogger..... | 3-34 | |
| Deicer..... | 3-34 | |
| Differential gear oil | | |
| Front..... | 11-26 | |
| Rear..... | 11-27 | |
| Dimensions..... | 12-2 | |
| Disarming the alarm system..... | 2-18 | |
| Disc brake pad wear warning indicators..... | 7-24 | |
| Dome light..... | 6-2, 11-58 | |
| Door | | |
| Locks..... | 2-5 | |
| Open indicator light..... | 3-20 | |
| Open warning light..... | 3-20 | |
| Step light..... | 11-60 | |
| Double trip meter..... | 3-6 | |
| Drive belts..... | 11-23 | |
| Driving | | |
| All-Wheel Drive warning light..... | 3-20 | |
| AWD vehicles..... | 8-5 | |
| Car phone/cell phone..... | 7 | |
| Drinking..... | 6 | |
| Drugs..... | 7 | |
| Foreign countries..... | 8-4 | |
| Off road..... | 8-6 | |
| Pets..... | 8 | |
| Snowy and icy roads..... | 8-9 | |
| Tips..... | 7-17, 7-23, 8-2, 8-5 | |
| Tired or sleepy..... | 7 | |
| Winter..... | 8-8 | |
| E | | |
| ECO gauge..... | 3-8 | |

- Electrical system..... 12-3
- Electronic Brake Force Distribution (EBD) system..... 3-18, 7-26
- Electronic parking brake..... 7-34
 - Automatic release function by gas pedal..... 7-35
 - Hill Holder..... 7-35
 - Warning..... 3-19, 7-37
- Emergency Locking Retractor (ELR)..... 1-13
- Engine
 - Compartment overview..... 11-9
 - Coolant..... 11-18
 - Exhaust gas (carbon monoxide)..... 6, 8-2
 - Hood..... 11-7
 - Low oil level warning light..... 3-14
 - Oil..... 11-12
 - Overheating..... 9-12
 - Starting..... 7-8
 - Stopping..... 7-10
- Exterior care..... 10-2
- F**
- Flat tires..... 9-6
- Floor mat..... 6-14
- Fluid level
 - Automatic transmission..... 11-24
 - Brake..... 11-30
 - Clutch..... 11-31
 - Power steering..... 11-29
- Fog light
 - Bulb..... 11-53
 - Indicator light..... 3-23
- Switch..... 3-30
- Front
 - Differential gear oil..... 11-26
 - Fog light..... 3-30, 11-53
 - Fog light indicator light..... 3-23
 - Position light..... 11-53
 - Seatbelt pretensioners..... 1-22
 - Turn signal light..... 11-53
- Front seats..... 1-2
 - Forward and backward adjustment..... 1-3
 - Power seat..... 1-4
 - Reclining..... 1-3
 - Seat height adjustment (driver's seat)..... 1-4
- Fuel..... 7-2
 - Economy hints..... 8-2
 - Filler lid and cap..... 7-3
 - Gauge..... 3-7
 - Requirements..... 7-2
- Fuses..... 11-48
 - Main fuse..... 11-50
- Fuses and circuits..... 12-6
- G**
- GAWR (Gross Axle Weight Rating)..... 8-13
- Glove box..... 6-6
- GVWR (Gross Vehicle Weight Rating)..... 8-13
- H**
- Hands-free system..... 5-32
- Hazard warning flasher..... 3-5, 9-2
- Head restraint adjustment

| | |
|--|-------------|
| Front seat | 1-5 |
| Rear seat | 1-10 |
| Headlight | 3-27, 11-50 |
| Flasher | 3-28 |
| Indicator light | 3-23 |
| Heater operation (manual climate control system) | 4-6 |
| High beam indicator light | 3-23 |
| High/low beam change (dimmer) | 3-28 |
| Hill Holder | 7-35 |
| Indicator light | 3-19, 7-36 |
| Switch | 7-35 |
| Hook | |
| Coat | 6-13 |
| Convenient tie-down | 6-17 |
| Shopping bag | 6-14 |
| Towing and tie-down | 9-13 |
| Horn | 3-39 |
| Hose and connections | 11-17 |
| I | |
| Ignition switch | 3-3 |
| Light | 3-4 |
| Illumination brightness control | 3-30 |
| Immobilizer | 2-3 |
| Indicator light (security indicator light) | 2-4, 3-22 |
| Indicator light | |
| Coolant temperature low | 3-13 |
| Cruise control | 3-23, 7-41 |
| Cruise control set | 3-23, 7-41 |
| Door open | 3-20 |
| Front fog light | 3-23 |

| | |
|--|------------|
| Headlight | 3-23 |
| High beam | 3-23 |
| Security | 2-4, 3-22 |
| Select lever/Gear position | 3-22 |
| Turn signal | 3-23 |
| Vehicle Dynamics Control OFF | 3-21, 7-31 |
| Vehicle Dynamics Control operation | 3-21, 7-30 |
| Inside mirror | 3-36 |
| Interior lights | 6-2 |
| Internal trunk lid release handle | 2-25 |
| J | |
| Jack-up point | 9-6 |
| Jump starting | 9-10 |
| K | |
| Key | 2-2 |
| Number | 2-2 |
| Reminder chime | 3-4 |
| Replacement | 2-4 |
| Keyless entry system | 2-8 |
| L | |
| Leather seat materials | 10-5 |
| License plate light | 11-57 |
| Light | |
| Back-up (Legacy) | 11-54 |
| Brake (Outback) | 11-55 |
| Brake/Tail and rear side marker (Legacy) | 11-54 |
| Cargo area | 6-3, 11-60 |
| Control switch | 3-27 |

| | |
|--|--------------------|
| Dome | 6-2, 11-58 |
| Door step | 11-60 |
| Front fog | 3-30, 11-53 |
| Front position | 11-53 |
| Ignition switch | 3-4 |
| License plate | 11-57 |
| Map | 6-2, 11-59 |
| Rear combination | 11-54 |
| Tail and rear side marker (Outback) | 11-55 |
| Tail/Back-up (Outback) | 11-56 |
| Trunk | 11-60 |
| Turn signal | 3-29, 11-53, 11-54 |
| Vanity mirror | 6-5, 11-59 |
| Loading your vehicle | 8-12 |
| Low fuel warning light | 3-8, 3-19 |
| Low tire pressure warning light | 3-15 |
| Lower and tether anchorage | 1-33 |
| M | |
| Main fuse | 11-50 |
| Maintenance | |
| Precautions | 11-3 |
| Schedule | 11-3 |
| Seatbelt | 1-22 |
| Tips | 11-5 |
| Tools | 9-3 |
| Malfunction indicator lamp (check engine warning light) | 3-12 |
| Manual | |
| Climate control system | 4-4 |
| Mode | 7-21 |

| | |
|------------------------------------|------------|
| Seat | 1-3 |
| Transmission | 7-16 |
| Transmission oil | 11-23 |
| Map light | 6-2, 11-59 |
| Maximum load limits | 8-19 |
| Meters and gauges | 3-5 |
| Mirror defogger | 3-34 |
| Mirrors | 3-36 |
| Moonroof | 2-28, 9-20 |
| Multi function display | 3-24 |
| N | |
| New vehicle break-in driving | 8-2 |
| O | |
| Odometer | 3-6 |
| Off road driving | 8-6 |
| Oil filter | 11-14 |
| Oil level | |
| Engine | 11-12 |
| Front differential gear | 11-26 |
| Manual transmission | 11-23 |
| Rear differential gear | 11-27 |
| Warning light | 3-14 |
| Oil pressure warning light | 3-14 |
| Outside | |
| Mirror defogger | 3-34 |
| Mirrors | 3-38 |
| Overhead console | 6-8 |
| Overheating engine | 9-12 |

- P**
- Parking 7-33
 - Brake 7-34
 - Tips 7-37
 - Periodic inspections 8-4
 - Petrol fuel 7-2
 - Pocket 6-8
 - Power
 - Door locking switch 2-7
 - Seat 1-4
 - Steering 7-23
 - Steering fluid 11-29
 - Window 2-21
 - Precautions against vehicle modification 1-24, 1-64
 - Preparing to drive 7-7
 - Printed antenna 5-2
- R**
- Rear
 - Combination lights 11-54
 - Differential gear oil 11-27
 - Gate 2-27, 9-19
 - Turn signal light 11-54
 - Rear seat 1-7
 - Folding down 1-8
 - Reclining 1-8
 - Rear view camera 6-19
 - Rear window
 - Defogger 3-34
 - Wiper and washer switch 3-34
 - Wiper blades 11-45
- Recommended**
- Automatic transmission fluid 11-25
 - Brake fluid 11-31
 - Clutch fluid 11-32
 - Engine oil 11-16, 11-17
 - Front differential gear oil 11-27
 - Manual transmission oil 11-24
 - Power steering fluid 11-30
 - Rear differential gear oil 11-28
 - Spark plugs 11-22
- Refueling 7-3
- Remote engine start system 7-10
 - Remote keyless entry system 2-8
- Replacement
- Brake pad and lining 11-34
 - Wiper blades 11-43
- Replacing
- Air cleaner element 11-21
 - Battery (remote engine start transmitter) 7-14
 - Battery (remote keyless entry system) 2-11
 - Lost transmitters (remote keyless entry system) 2-12
- Replacing bulbs 11-50
- Back-up light (Legacy) 11-54
 - Brake light (Outback) 11-55
 - Brake/Tail and rear side marker light (Legacy) 11-54
 - Cargo area light 11-60
 - Dome light 11-58
 - Door step light 11-60
 - Front fog light 11-53
 - Front position light 11-53
 - Front turn signal light 11-53

| | |
|---|-------|
| Headlight | 11-50 |
| License plate light | 11-57 |
| Map light | 11-59 |
| Rear combination light | 11-54 |
| Tail and rear side marker light (Outback) | 11-55 |
| Tail/Back-up light (Outback) | 11-56 |
| Trunk light | 11-60 |
| Vanity mirror light | 11-59 |
| Rocking the vehicle | 8-11 |
| Roof rails with integrated cross bars | 8-14 |

S

Safety

| | |
|--------------------------------|---|
| Precautions when driving | 4 |
| Symbol | 2 |
| Warnings | 2 |

Seat

| | |
|-------------------------|------|
| Fabric | 10-5 |
| Front | 1-2 |
| Heater | 1-6 |
| Height adjustment | 1-4 |
| Rear | 1-7 |

| | |
|-------------------------------|------------|
| Seatbelt | 4, 1-12 |
| Fastening | 1-15 |
| Maintenance | 1-22 |
| Pretensioners | 1-22 |
| Safety tips | 1-12 |
| Warning light and chime | 1-14, 3-10 |

Security

| | |
|--------------------|------|
| Alarm system | 2-16 |
| ID plate | 2-3 |

| | |
|---|-------------|
| Immobilizer | 2-3 |
| Indicator light | 2-4, 3-22 |
| Shock sensors | 2-19 |
| Select lever | 7-19 |
| Position indicator | 3-22 |
| Shift lock function | 7-20 |
| Shock sensors | 2-19 |
| Shopping bag hook | 6-14 |
| Snow tires | 8-10, 11-35 |
| Snowy and icy roads | 8-9 |
| Sounding a panic alarm | 2-10 |
| Spark plugs | 11-22 |
| Specifications | 12-2 |
| Speedometer | 3-6 |
| SRS | |
| Curtain airbag | 1-53 |
| Frontal airbag | 1-43 |
| Side airbag | 1-53 |
| SRS airbag (Supplemental Restraint System airbag) ... | 4, 1-38 |
| SRS airbag system | |
| Monitors | 1-62 |
| Servicing | 1-63 |
| Warning light | 3-11 |
| Starting the engine | 7-8 |
| State emission testing (U.S. only) | 7-6 |
| Steering wheel | |
| Power | 7-23 |
| Tilt/telescopic | 3-38 |
| Stopping the engine | 7-10 |
| Storage compartment | 6-5 |
| Sun shade | 2-30 |

| | |
|---|------|
| Sun visors..... | 6-4 |
| Supplemental Restraint System airbag (SRS)..... | 1-38 |
| Synthetic leather upholstery | 10-5 |

T

| | |
|---|------------------|
| Tachometer | 3-7 |
| Temperature warning light | |
| AT OIL TEMP | 3-15 |
| Coolant..... | 3-13 |
| Temporary spare tire | 9-2 |
| Tether (child restraint system)..... | 1-33, 1-35 |
| Tie-down hooks | 9-13 |
| Tire | 11-35, 12-5 |
| Chains..... | 8-11 |
| Inspection | 11-37 |
| Pressures and wear | 11-37 |
| Replacement..... | 11-41 |
| Rotation..... | 11-40 |
| Types | 11-35 |
| Tire pressure monitoring system (TPMS)..... | 7-32, 9-9, 11-35 |
| Warning light | 3-15 |
| Tires and wheels..... | 11-35 |
| Tools | 9-3 |
| Top tether anchorages | 1-33, 1-35 |
| Towing..... | 9-12 |
| All wheels on the ground | 9-15 |
| Flat-bed truck | 9-15 |
| Hooks..... | 9-13 |
| Weight..... | 8-19 |
| Trailer | |
| Connecting..... | 8-17 |

| | |
|-----------------------|------------|
| Hitch..... | 8-16, 8-22 |
| Towing | 8-19 |
| Towing tips | 8-24 |
| Trip meter..... | 3-6 |
| Trunk lid..... | 2-24, 9-19 |
| Release handle | 2-25 |
| Trunk light | 11-60 |
| Turn signal | |
| Indicator lights..... | 3-23 |
| Lever | 3-29 |

U

| | |
|--------------------------------------|------|
| Under-floor storage compartment..... | 6-18 |
|--------------------------------------|------|

V

| | |
|--------------------------------|------------|
| Valet mode | 2-18 |
| Vanity mirror | 6-5, 11-59 |
| Light | 11-59 |
| Vehicle | |
| Capacity weight..... | 8-13 |
| Identification | 12-13 |
| Symbols | 3 |
| Vehicle Dynamics Control | |
| OFF indicator light | 3-21, 7-31 |
| OFF switch | 7-31 |
| Operation indicator light..... | 3-21, 7-30 |
| System..... | 7-28 |
| Warning light..... | 3-20, 7-29 |
| Ventilator | 4-2 |

W

| | |
|------------------------------------|------------|
| Warning and indicator lights | 3-9 |
| Warning light | |
| ABS | 3-16, 7-25 |
| All-Wheel Drive | 3-20 |
| AT OIL TEMP | 3-15 |
| Brake system | 3-17 |
| Charge | 3-14 |
| CHECK ENGINE | 3-12 |
| Coolant temperature high | 3-13 |
| Door open | 3-20 |
| Engine low oil level | 3-14 |
| Low fuel | 3-8, 3-19 |
| Low tire pressure | 3-15 |
| Oil pressure | 3-14 |
| Seatbelt | 1-14, 3-10 |
| SRS airbag system | 3-11 |
| Vehicle Dynamics Control | 3-20, 7-29 |
| Windshield washer fluid | 3-20 |
| Warranties | 1 |
| Warranties and maintenance | 8-19 |
| Washing | 10-2 |
| Waxing and polishing | 10-3 |
| Wear indicators | 11-39 |
| Wheel | |
| Alignment | 12-5 |
| Aluminum | 11-42 |
| Balance | 11-39 |
| Replacement | 11-41 |
| Windows | 2-21 |

| | |
|---------------------------------|-------------|
| Windshield | |
| Washer fluid | 11-42 |
| Wiper and washer switches | 3-32 |
| Wiper blades | 11-44 |
| Wiper deicer | 3-34 |
| Winter | |
| Driving | 8-8 |
| Tires | 8-10, 11-35 |
| Wiper and washer | 3-31 |
| Wiper deicer | 3-34 |

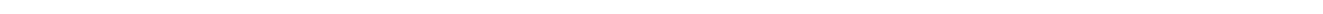
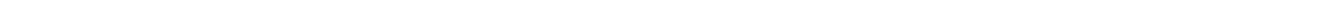
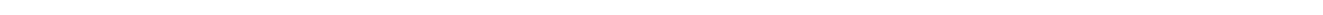
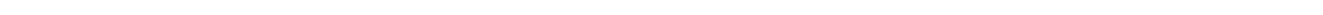
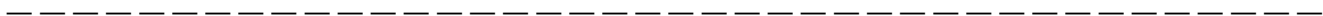
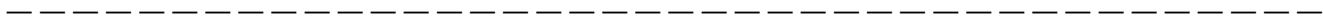

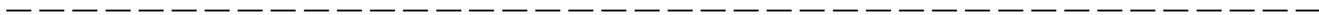
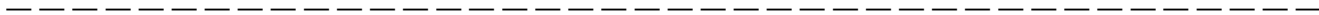
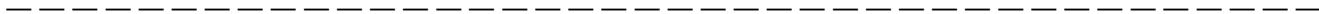
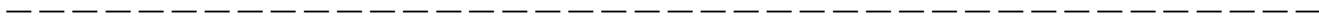
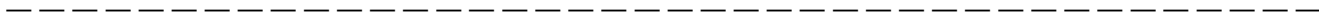
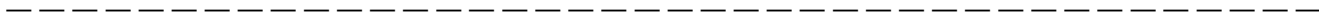
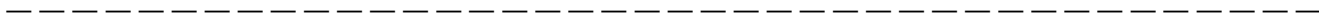
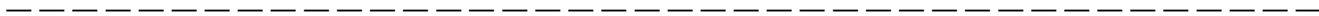
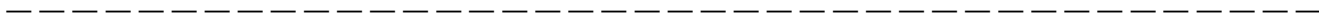
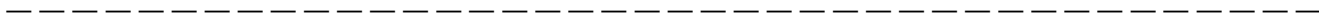

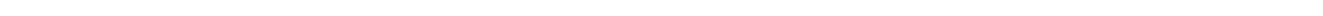
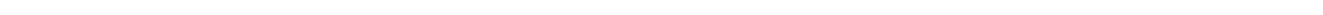
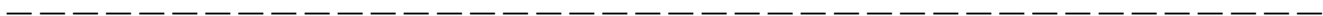
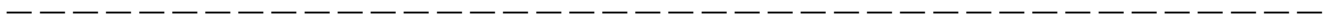

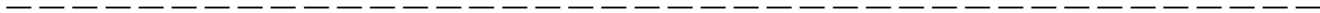
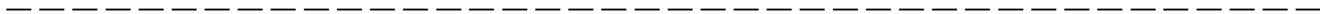
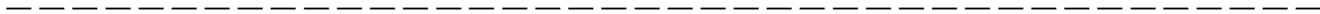
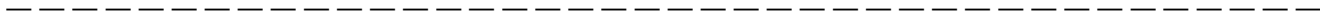
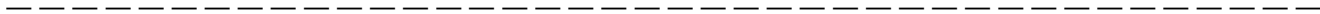
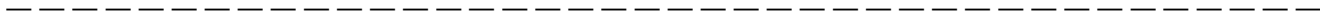
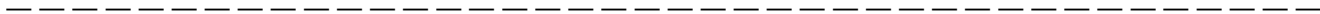

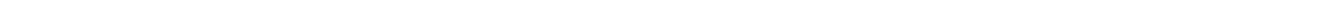
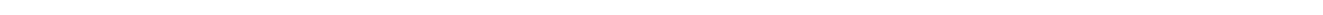
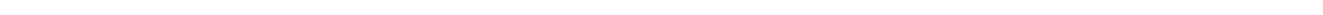
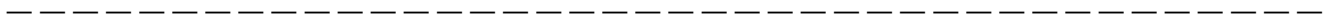

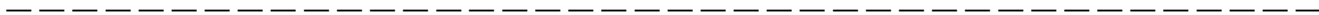
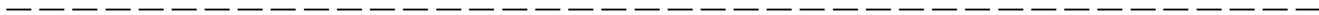
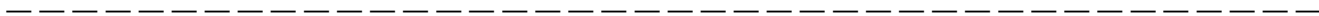
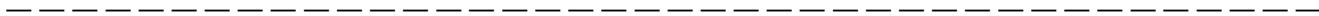
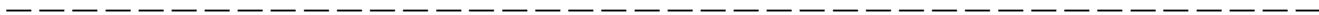
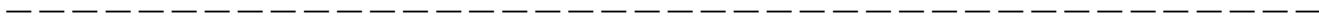
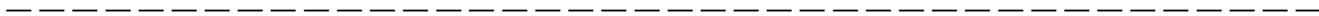
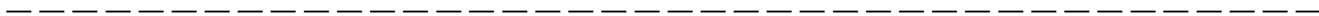
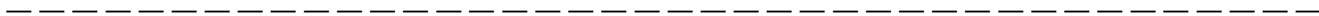

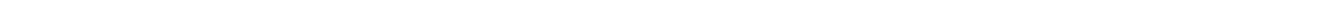
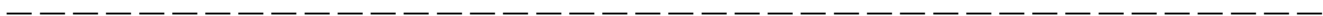
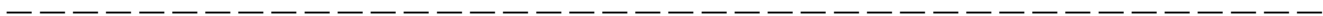

U.S. Compass Calibration Zones

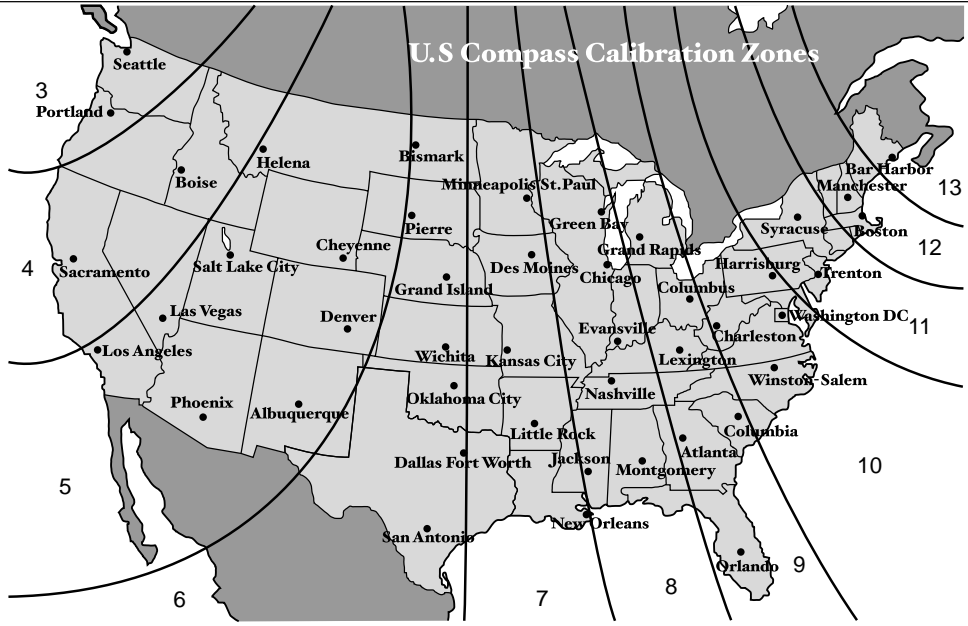

GAS STATION REFERENCE

■ Fuel:

▼ Non-turbo models

Use only **unleaded** gasoline with an octane rating of **87 AKI or higher**.

▼ Turbo models

Use **premium unleaded** gasoline with an octane rating of **93 AKI or higher**. For temporary purposes if premium unleaded gasoline is not available, you may use regular unleaded gasoline with an octane rating of 87 AKI or higher. For optimum engine performance and driveability, it is required that you use premium grade unleaded gasoline.

■ Fuel octane rating

This octane rating is the average of the Research Octane and Motor Octane numbers and is commonly referred to as the Anti Knock Index (AKI). Refer to "Fuel" [☞7-2](#) section in this manual.

■ Fuel capacity:

18.5 US gal (70 liters, 15.4 Imp gal)

■ Engine oil:

Use only API classification SM with the words "ENERGY CONSERVING" or ILSAC GF-4, which can be identified with the ILSAC certification mark (Starburst mark).

For the complete viscosity requirements, refer to the following sections.

- "Recommended grade and viscosity" [☞11-16](#)
- "Recommended grade and viscosity under severe driving conditions" [☞11-17](#)

■ Engine oil capacity:

2.5 L models: 4.2 US qt (4.0 liters, 3.5 Imp qt)

3.6 L models: 6.7 US qt (6.3 liters, 5.5 Imp qt)

■ Cold tire pressure:

| | | | | | | | |
|----------------------|----------|-----------------------------|-------------------|-------------------|-------------------|-------------------|------------------|
| Tire size | | P205/60R16 91V | P215/70R16 99S | P225/60R17 98T | P215/50R17 90V | P225/50R17 93V | 225/45R18 91W |
| Wheel size | | 16 × 6 1/2JJ 16 × 6 1/2J | 16 × 6 1/2JJ | 17 × 7J | 17 × 7 1/2J | | 18 × 7 1/2J |
| Pressure | Front | 33 psi (230 kPa) | 32 psi (220 kPa) | | 33 psi (230 kPa) | | |
| | Rear | 32 psi (220 kPa) | 30 psi (210 kPa) | | 32 psi (220 kPa) | | |
| Temporary spare tire | Size | T135/80R16 | T145/80R17 | | T135/70R17 | | |
| | Pressure | 60 psi (420 kPa) | | | | | |



FUJI HEAVY INDUSTRIES LTD.
TOKYO, JAPAN



A2460BE-A
Issued May 2009
Printed in USA 05/09
2010A

英語



M5A5M1004A