

15.Rear Gate Glass

A: REMOVAL

- 1) Disconnect the ground cable from battery.
- 2) Remove the rear gate trim. <Ref. to EI-157, REMOVAL, Rear Gate Trim.>
- 3) Remove the rear gate garnish. <Ref. to EI-161, REMOVAL, Rear Gate Garnish.>
- 4) Remove the rear wiper motor. <Ref. to WW-37, REMOVAL, Rear Wiper Motor.>
- 5) Disconnect the rear defogger connector and radio antenna connector.
- 6) Remove the rear gate in the same procedure as for windshield glass. <Ref. to GW-36, REMOVAL, Windshield Glass.>

B: INSTALLATION

NOTE:

When applying adhesive and installing the dam rubber and molding, refer to Ag printing as a mark.

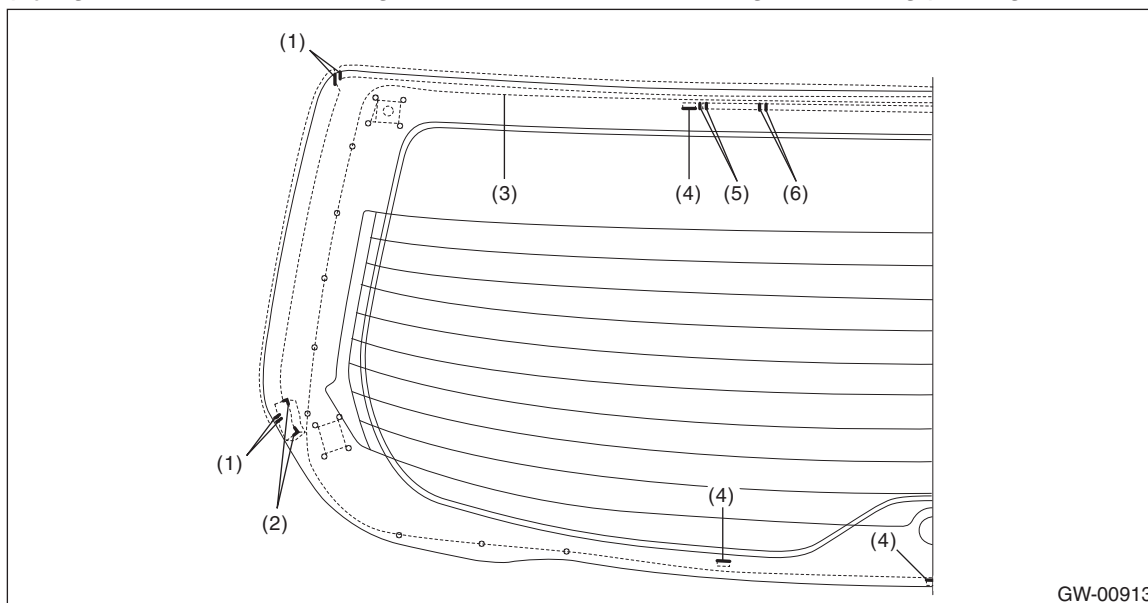

- (1) Molding edge
- (2) EPT SEALER edge

- (3) Adhesive line
- (4) Spacer edge

- (5) Dam rubber edge (LH)
- (6) Dam rubber edge (RH)

Rear Gate Glass

1) Cut the cartridge nozzle tip as shown in the figure, and set the adhesive in the sealant gun.

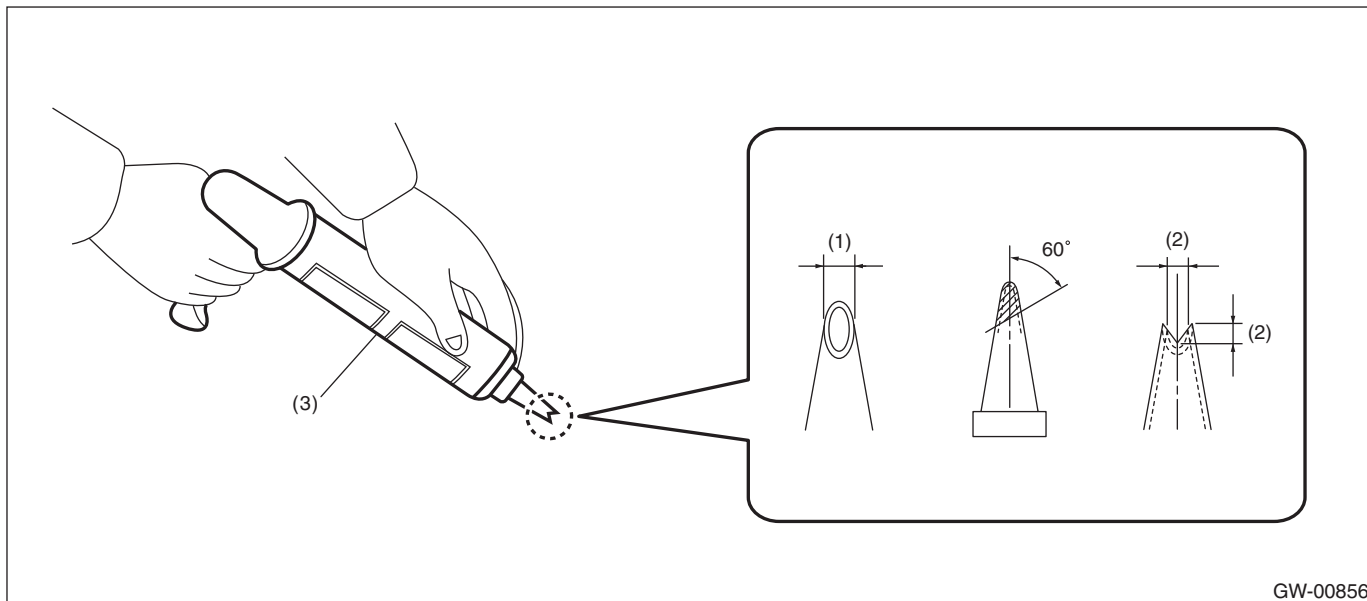

(1) 10 mm (0.39 in)

(2) 8 mm (0.31 in)

(3) Sealant gun

2) Prepare and clean the adhesion surfaces of the glass and body using the same procedures as for the windshield glass. <Ref. to GW-39, INSTALLATION, Windshield Glass.>

3) Attach the dam rubber to the glass.

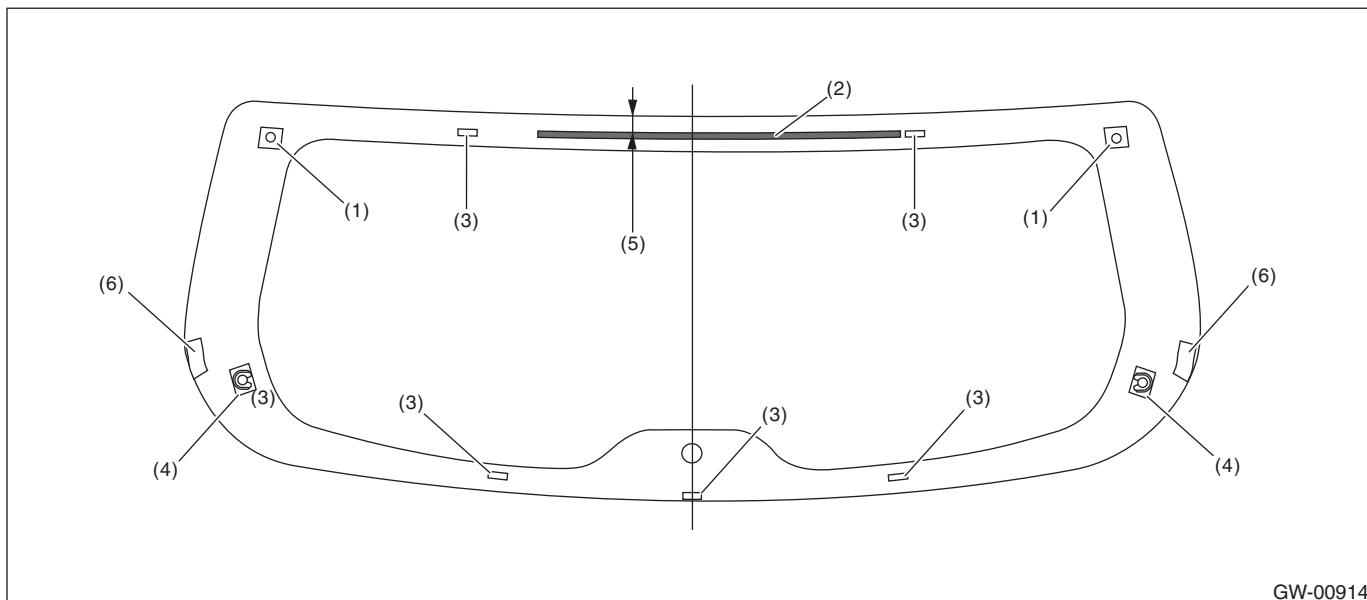

(1) Locating pin

(3) SPACER

(5) 15 mm (0.59 in)

(2) Dam rubber

(4) HOLDER

(6) EPT sealer

Rear Gate Glass

GLASS/WINDOWS/MIRRORS

4) Attach the molding to the glass.

CAUTION:

Be careful to attach the molding so that the molding has no loose or undulating part.

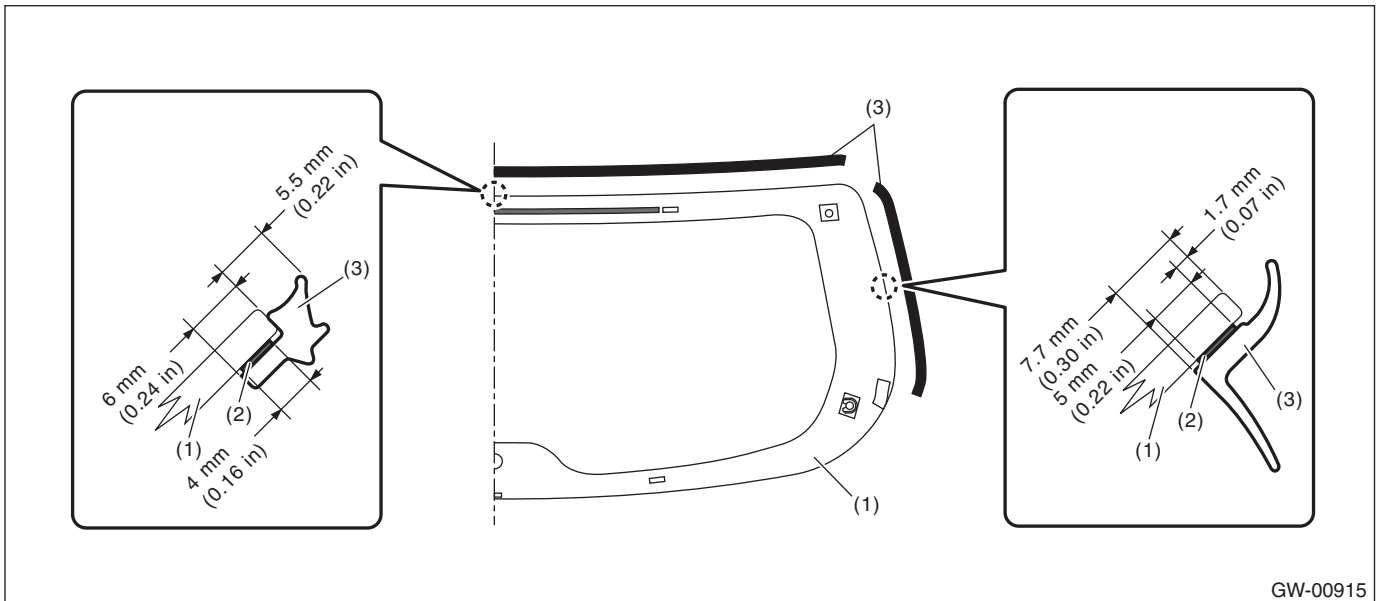

GW-00915

(1) Rear gate glass

(2) Double-sided tape

(3) Molding

5) Install the rear gate glass.

(1) Using a sponge, apply primer to the glass side and body side adhesive surfaces.

(2) Apply adhesive to the glass end back surface.

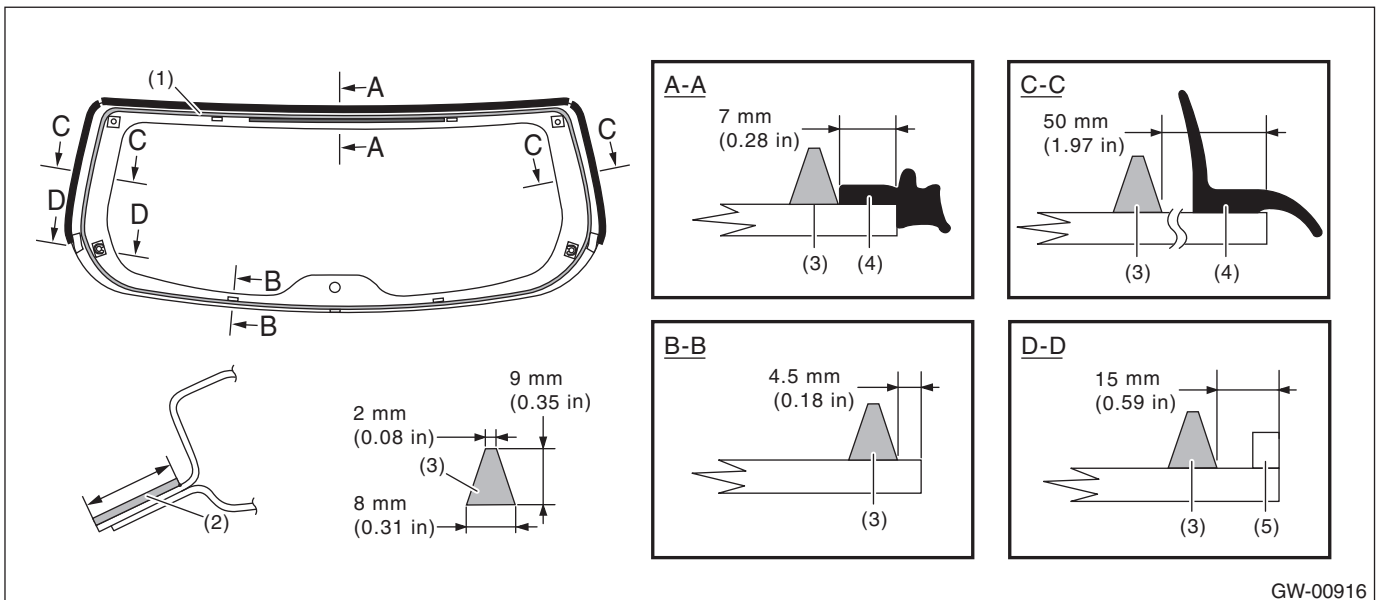

GW-00916

(1) Application of primer (glass side)

(3) Adhesive

(5) EPT sealer

(2) Application of primer (body side)

(4) Molding

(3) Attach the clip to the rear gate glass holder.

(4) Insert the glass locating pins in the rear gate panel holes and install the rear gate glass.

(5) Lightly press the entire perimeter of rear gate glass for tight fit.

(6) Make flush the adhesive surface juttred out using spatula.

6) After completion of all work, allow the vehicle to stand for about 24 hours.

NOTE:

- When door is opened/closed after glass is bonded, always lower the door glass first, and then open/close it carefully.
- Move the vehicle slowly.
- For minimum drying time and vehicle standing time before driving after bonding, follow instructions or instruction manual from the adhesive manufacturer.

7) After curing of adhesive, pour the water on external surface of vehicle to check that there are no water leaks.

NOTE:

When a vehicle is returned to the user, tell him or her that the vehicle should not be subjected to heavy impact for at least three days.

8) Connect the rear defogger connector and radio antenna connector.

9) Install the rear wiper motor. <Ref. to WW-40, INSTALLATION, Rear Wiper Motor.>

10) Install the rear gate garnish. <Ref. to EI-163, INSTALLATION, Rear Gate Garnish.>

11) Install the rear gate trim. <Ref. to EI-158, INSTALLATION, Rear Gate Trim.>