

Rear Window Glass

GLASS/WINDOWS/MIRRORS

16.Rear Window Glass

A: REMOVAL

- 1) Disconnect the ground cable from battery.
- 2) Disconnect the rear defogger connector and radio antenna connector.
- 3) Remove the glass in the same procedure as for windshield glass. <Ref. to GW-36, REMOVAL, Windshield Glass.>

B: INSTALLATION

- 1) Cut the cartridge nozzle tip as shown in the figure, and set the adhesive in the sealant gun.

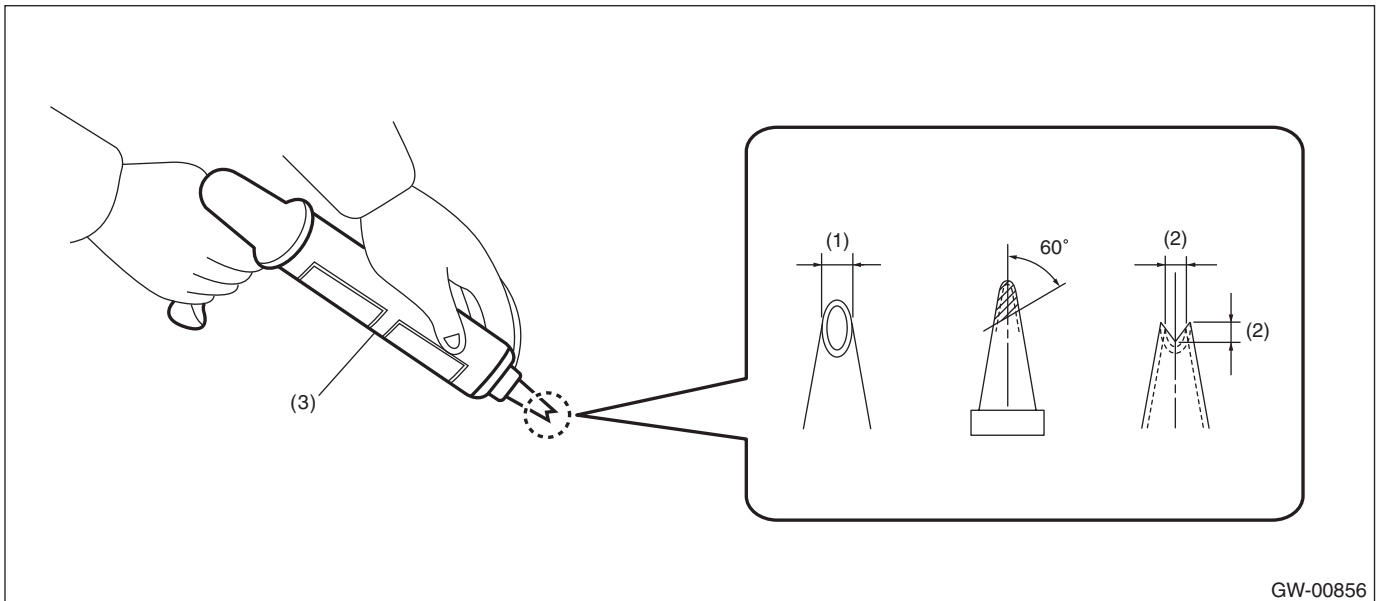

(1) 10 mm (0.39 in)

(2) 8 mm (0.31 in)

(3) Sealant gun

- 2) Prepare and clean the adhesion surfaces of the glass and body using the same procedures as for the windshield glass. <Ref. to GW-39, INSTALLATION, Windshield Glass.>

- 3) Attach the dam rubber to the glass.

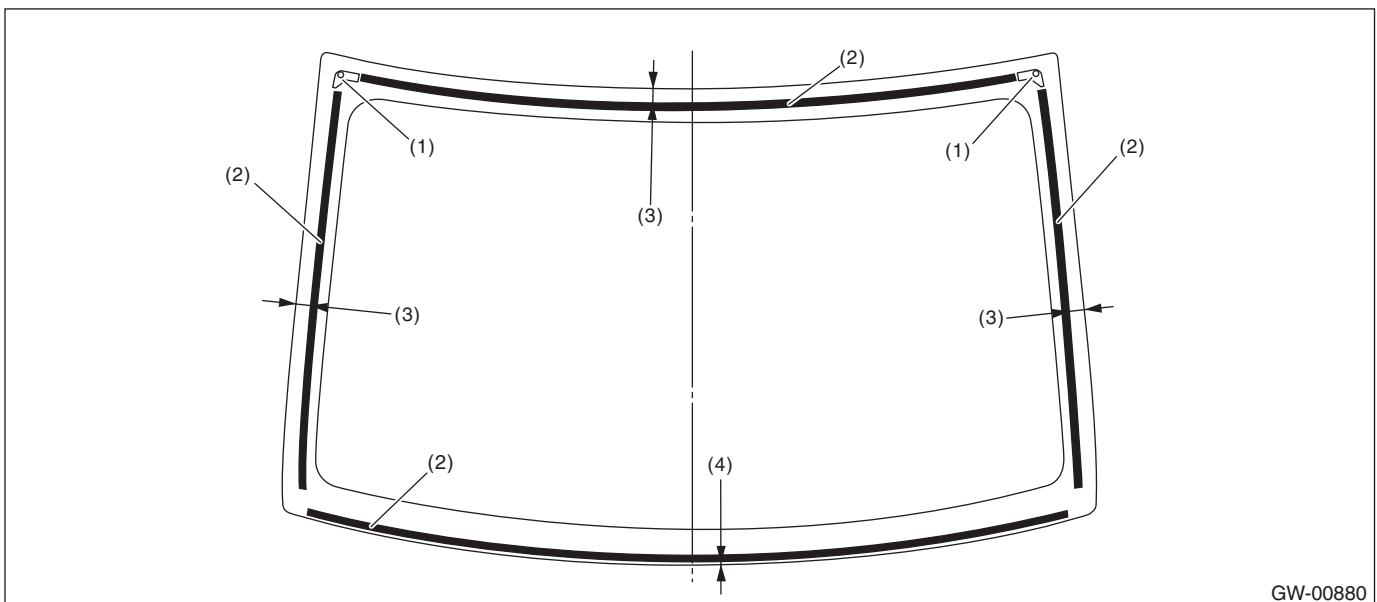

(1) Locating pin

(3) 16 mm (0.63 in)

(4) 1 mm (0.04 in)

(2) Dam rubber

4) Attach the molding to the glass.

CAUTION:

Be careful to attach the molding so that the molding has no loose or undulating part.

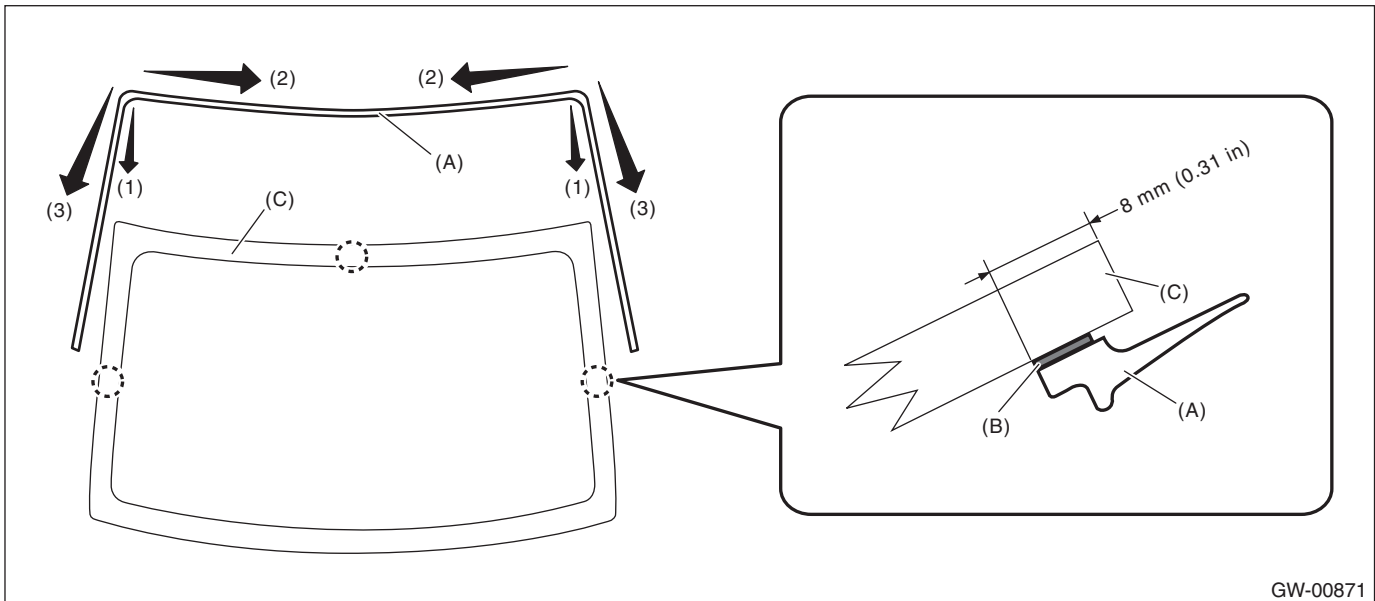

GW-00871

- (1) Align the molding (A) to the upper ends of the glass (C).
- (2) Attach the molding from the upper corners towards the center.
- (3) Attach the molding from the upper corners downward.
- (4) Firmly apply the double sided tape (B) of the molding evenly to the glass surface.

5) Install the rear glass in the same procedure as for windshield glass. <Ref. to GW-39, INSTALLATION, Windshield Glass.>

- (1) Using a sponge, apply primer to the glass side and body side adhesive surfaces.
- (2) Apply adhesive to the glass end back surface.

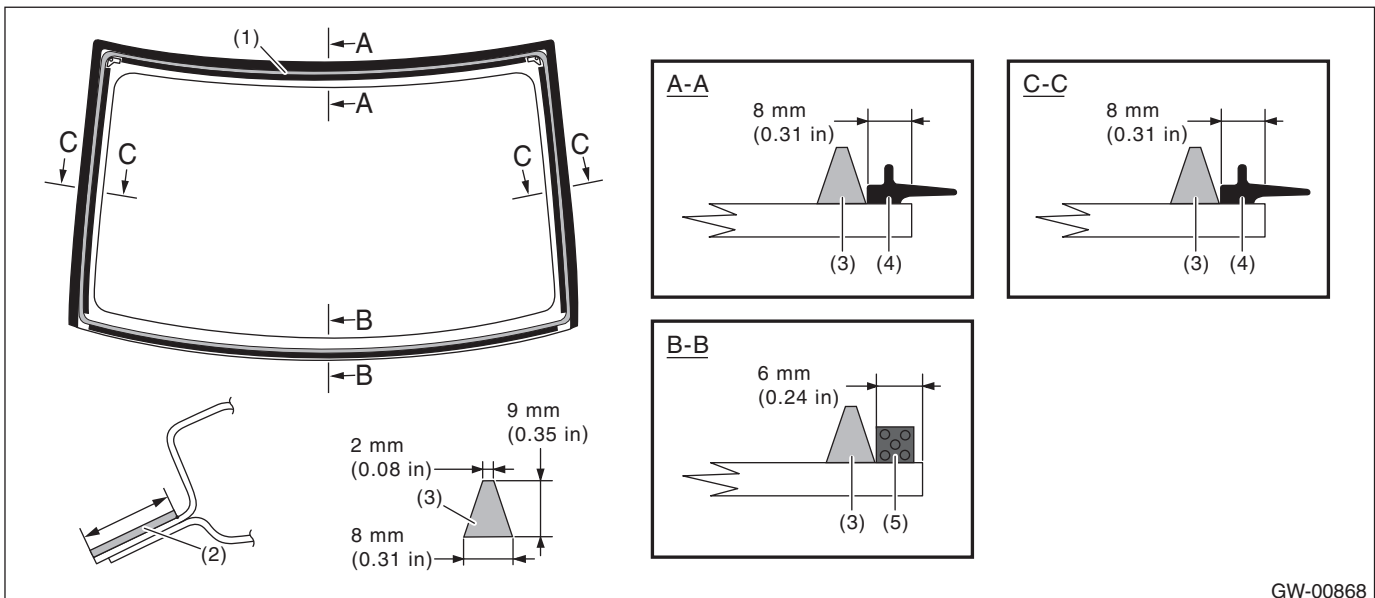

GW-00868

- | | | |
|--|--------------|----------------|
| (1) Application of primer (glass side) | (3) Adhesive | (5) Dam rubber |
| (2) Application of primer (body side) | (4) Molding | |

- (3) Insert the glass locating pins in the rear panel holes and install the rear glass.
- (4) Lightly press the entire perimeter of rear glass for tight fit.
- (5) Make flush the adhesive surface jugged out using spatula.

Rear Window Glass

GLASS/WINDOWS/MIRRORS

6) After completion of all work, allow the vehicle to stand for about 24 hours.

NOTE:

- When door is opened/closed after glass is bonded, always lower the door glass first, and then open/close it carefully.
- Move the vehicle slowly.
- For minimum drying time and vehicle standing time before driving after bonding, follow instructions or instruction manual from the adhesive manufacturer.

7) After curing of adhesive, pour the water on external surface of vehicle to check that there are no water leaks.

NOTE:

When a vehicle is returned to the user, tell him or her that the vehicle should not be subjected to heavy impact for at least three days.

8) Connect the rear defogger connector and radio antenna connector.