

18.Rear Quarter Glass

A: REMOVAL

- 1) Disconnect the ground cable from battery.
- 2) Remove the rear quarter trim. <Ref. to EI-114, OUTBACK MODEL, REMOVAL, Rear Quarter Trim.>
- 3) Remove the rear quarter glass in the same procedure as for windshield glass. <Ref. to GW-36, REMOVAL, Windshield Glass.>

B: INSTALLATION

- 1) Cut the cartridge nozzle tip as shown in the figure, and set the adhesive in the sealant gun.

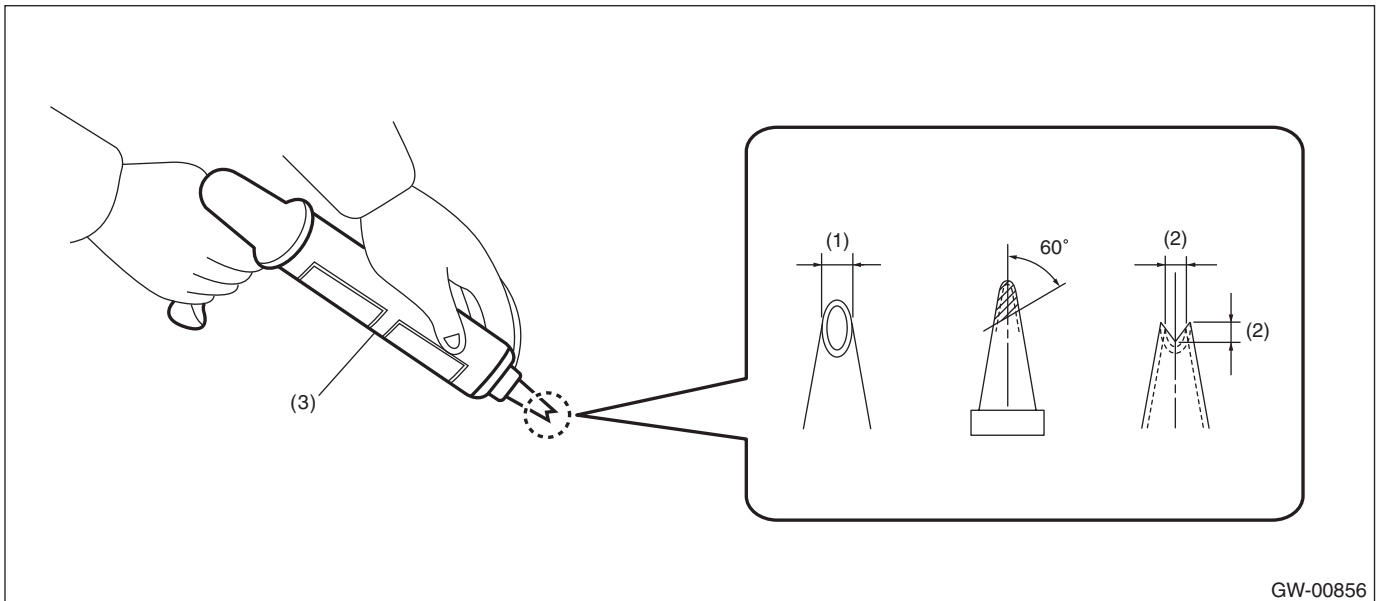

GW-00856

(1) 10 mm (0.39 in)

(2) 8 mm (0.31 in)

(3) Sealant gun

- 2) Prepare and clean the adhesion surfaces of the glass and body using the same procedures as for the windshield glass. <Ref. to GW-39, INSTALLATION, Windshield Glass.>

- 3) Attach the dam rubber to the glass.

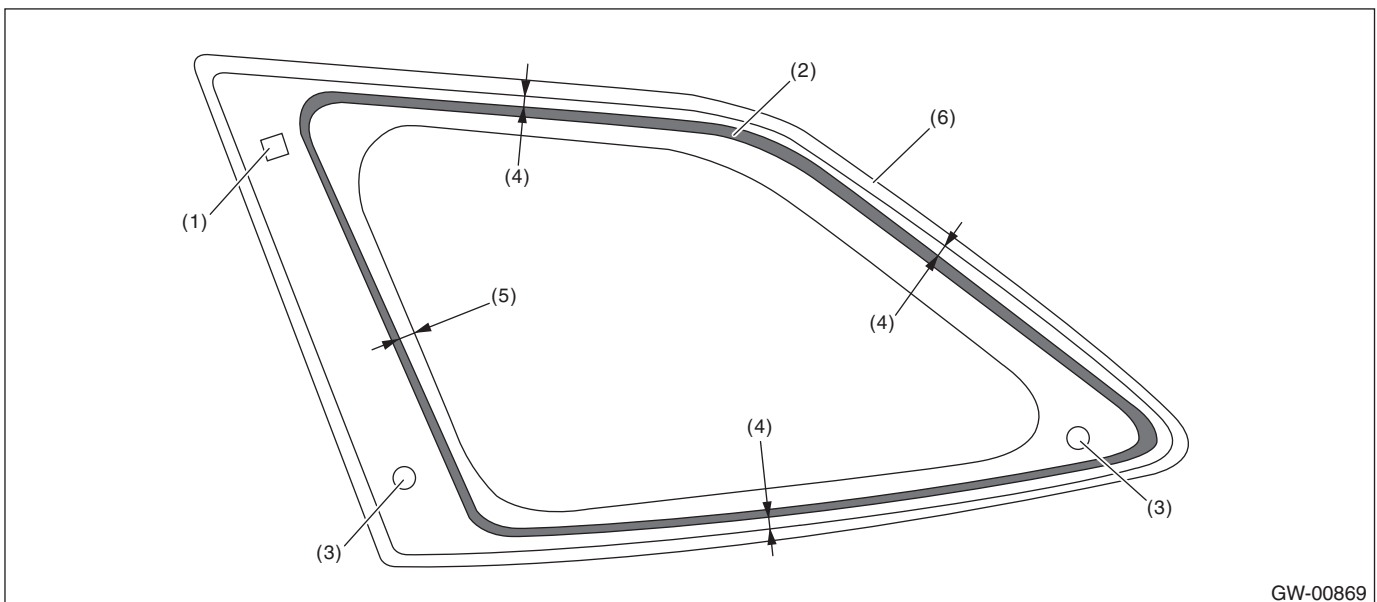

GW-00869

(1) Fastener

(2) Dam rubber

(3) Clip

(4) 8 mm (0.31 in)

(5) 12 mm (0.47 in)

(6) Molding

Rear Quarter Glass

GLASS/WINDOWS/MIRRORS

4) Install the rear quarter glass in the same procedure as for windshield glass. <Ref. to GW-39, INSTALLATION, Windshield Glass.>

- (1) Using a sponge, apply primer to the glass side and body side adhesive surfaces.
- (2) Apply adhesive to the glass end back surface.

NOTE:

Use the molding terminal as a reference.

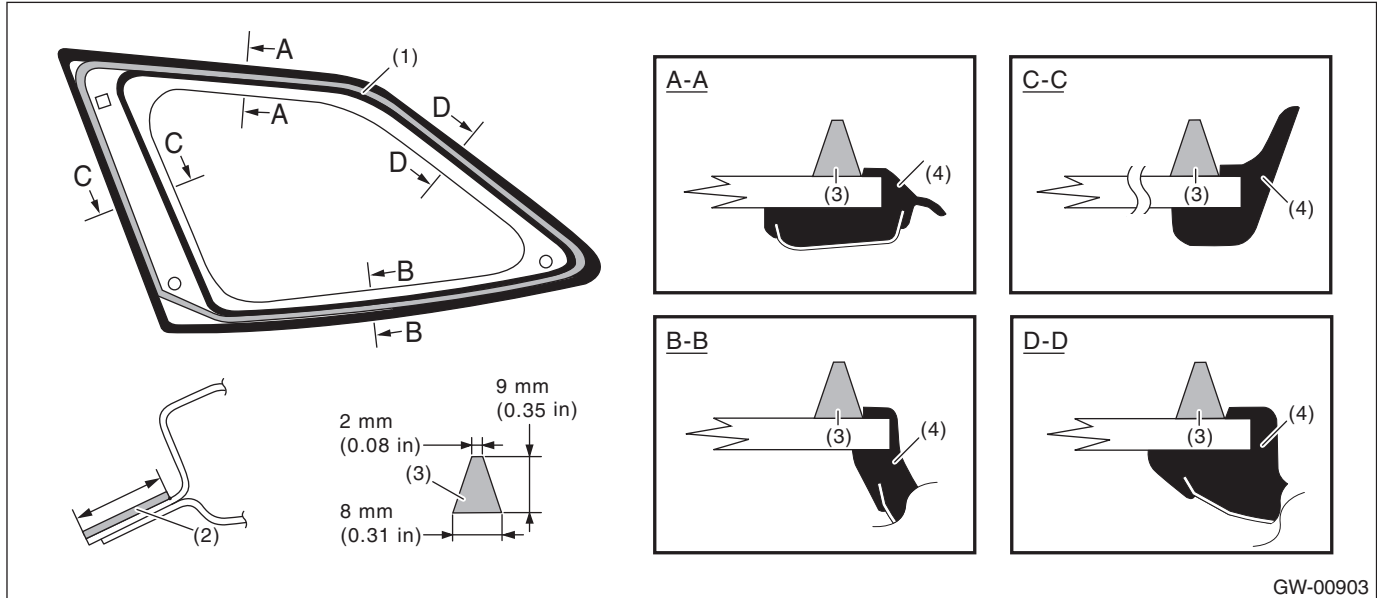

GW-00903

- (1) Application of primer (glass side) (3) Adhesive (4) Molding
(2) Application of primer (body side)

- (3) Attach the fastener to the body.
- (4) Insert the clips in the side panel holes and install the rear quarter glass.
- (5) Lightly press the entire perimeter of rear quarter glass for tight fit.
- (6) Make flush the adhesive surface jugged out using spatula.

5) After completion of all work, allow the vehicle to stand for about 24 hours.

NOTE:

- When door is opened/closed after glass is bonded, always lower the door glass first, and then open/close it carefully.
- Move the vehicle slowly.
- For minimum drying time and vehicle standing time before driving after bonding, follow instructions or instruction manual from the adhesive manufacturer.

6) After curing of adhesive, pour the water on external surface of vehicle to check that there are no water leaks.

NOTE:

When a vehicle is returned to the user, tell him or her that the vehicle should not be subjected to heavy impact for at least three days.

7) Install the rear quarter trim. <Ref. to EI-119, INSTALLATION, Rear Quarter Trim.>