

Diagnostic Procedure with Cancel Code

CRUISE CONTROL SYSTEM (DIAGNOSTICS)

10. Diagnostic Procedure with Cancel Code

A: 11

When CRUISE switch is pressed, or a malfunction related to CRUISE switch occurs, this is detected.

TROUBLE SYMPTOM:

- Cruise control cannot be set. (Cancelled immediately.)
- Cruise control cannot be released.

WIRING DIAGRAM:

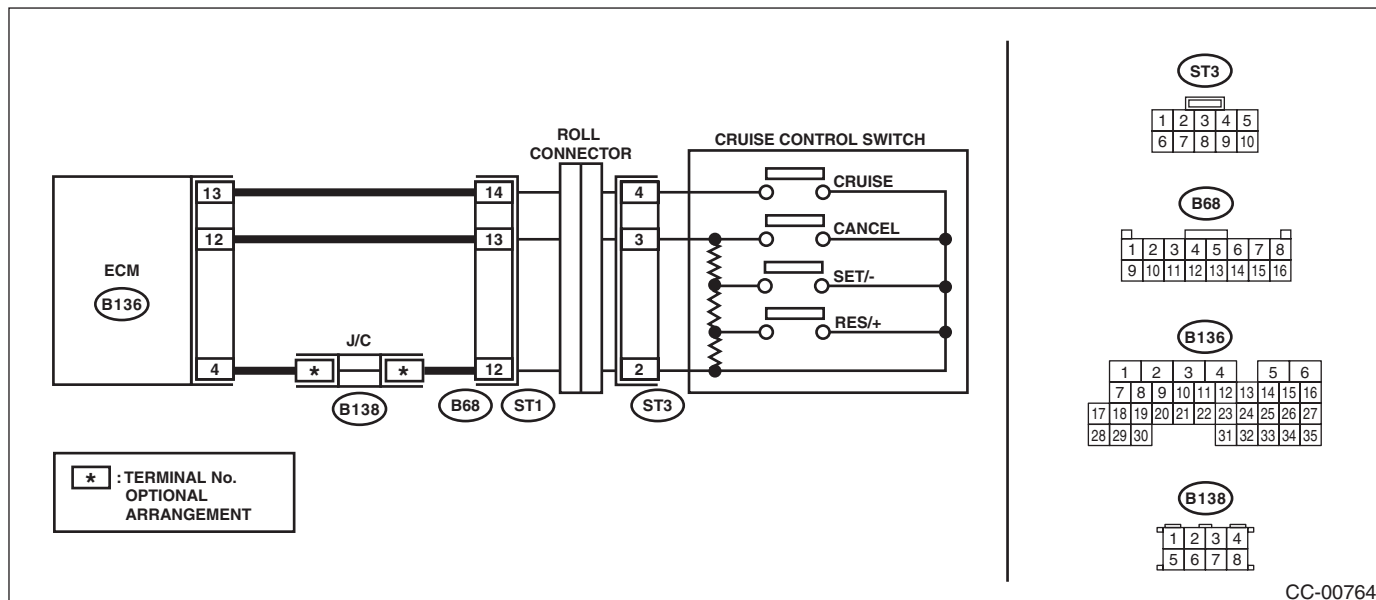

CC-00764

Step	Check	Yes	No
1 CHECK CRUISE CONTROL COMMAND SWITCH CIRCUIT. 1) Remove the driver's airbag module. <Ref. to AB-31, REMOVAL, Driver's Airbag Module.> 2) Disconnect the harness connector of cruise control command switch. 3) Turn the ignition switch to ON. 4) Measure the voltage between harness connector terminal and chassis ground. Connector & terminal (ST3) No. 4 (+) — Chassis ground (-): (ST3) No. 3 (+) — Chassis ground (-):	Is the voltage 5 V or more?	Go to step 2.	Check the harness between cruise control command switch and ECM, and the steering roll connector for open or short circuit, or for poor contact.
2 CHECK CRUISE CONTROL COMMAND SWITCH CIRCUIT. 1) Turn the ignition switch to OFF. 2) Remove the cruise control command switch. <Ref. to CC-7, REMOVAL, Cruise Control Command Switch.> 3) Measure the resistance between harness connector terminal and chassis ground. Connector & terminal (ST3) No. 2 — Chassis ground:	Is the resistance less than 10 Ω ?	Go to step 3.	Check for open circuit between cruise control command switch, ECM, and chassis ground and check the ECM.
3 CHECK CRUISE CONTROL COMMAND SWITCH. Measure the resistance between switch terminals when the cruise control command switch is not depressed. Terminals No. 2 — No. 3:	Is the resistance approx. 4 k Ω ?	Go to step 4.	Replace the cruise control command switch. <Ref. to CC-7, Cruise Control Command Switch.>

Diagnostic Procedure with Cancel Code

CRUISE CONTROL SYSTEM (DIAGNOSTICS)

Step	Check	Yes	No
<p>4 CHECK CANCEL SWITCH. 1) Turn the ignition switch to OFF. 2) Remove the cruise control command switch. <Ref. to CC-7, REMOVAL, Cruise Control Command Switch.> 3) Measure the resistance between switch terminals with the CANCEL switch pressed. Terminals No. 2 — No. 3:</p>	<p>Is the resistance approx. less than 1 Ω when the CANCEL switch is pressed?</p>	<p>Go to step 5.</p>	<p>Replace the cruise control command switch. <Ref. to CC-7, Cruise Control Command Switch.></p>
<p>5 CHECK SET/COAST SWITCH. Measure the resistance between switch terminals with the SET/COAST switch pressed. Terminals No. 2 — No. 3:</p>	<p>Is the resistance approx. 250 Ω when SET/COAST switch is pressed?</p>	<p>Go to step 6.</p>	<p>Replace the cruise control command switch. <Ref. to CC-7, Cruise Control Command Switch.></p>
<p>6 CHECK RESUME/ACCEL SWITCH CIRCUIT. Measure the resistance between switch terminals with the RESUME/ACCEL switch pressed. Terminals No. 2 — No. 3:</p>	<p>Is the resistance approx. 1,500 Ω when RESUME/ACCEL switch is pressed?</p>	<p>Replace the ECM. <Ref. to FU(H4SO)-39, Engine Control Module (ECM).> <Ref. to FU(H4DOTC)-57, Engine Control Module (ECM).> <Ref. to FU(H6DO)-50, Engine Control Module (ECM).></p>	<p>Replace the cruise control command switch. <Ref. to CC-7, Cruise Control Command Switch.></p>

Diagnostic Procedure with Cancel Code

CRUISE CONTROL SYSTEM (DIAGNOSTICS)

B: 12

Detected when brake pedal is depressed or malfunction related to stop light & brake switch occurs.

TROUBLE SYMPTOM:

- Cruise control cannot be set.
- Cruise control cannot be released.

WIRING DIAGRAM:

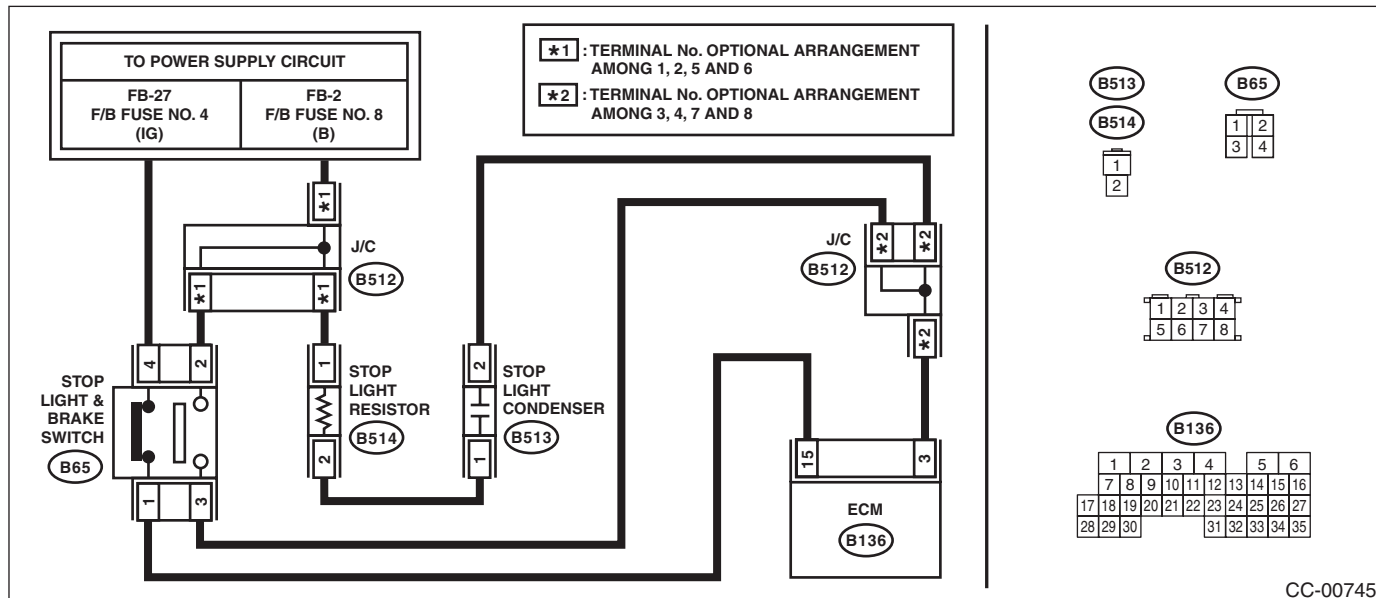

Step	Check	Yes	No
1	CHECK STOP LIGHT & BRAKE SWITCH. Check the stop light & brake switch. <Ref. to CC-12, Stop Light & Brake Switch.>	Go to step 2.	Replace the stop light & brake switch. Or adjust the installation position.
2	CHECK STOP LIGHT & BRAKE SWITCH CIRCUIT. 1) Turn the ignition switch to OFF. 2) Disconnect the stop light & brake switch harness connector. 3) Turn the ignition switch to ON. 4) Measure the voltage between harness connector terminal and chassis ground. Connector & terminal (B65) No. 2 (+) — Chassis ground (-):	Go to step 3.	<ul style="list-style-type: none"> • Check fuse No. 8 (in fuse & relay box). • Check for open or short circuit in the harness between stop light/brake switch and fuse and relay box.
3	CHECK STOP LIGHT & BRAKE SWITCH CIRCUIT. Measure the voltage between harness connector terminal and chassis ground. Connector & terminal (B65) No. 4 (+) — Chassis ground (-):	Go to step 4.	<ul style="list-style-type: none"> • Check fuse No. 4 (in fuse & relay box). • Check for open or short circuit in the harness between stop light/brake switch and fuse and relay box.

Diagnostic Procedure with Cancel Code

CRUISE CONTROL SYSTEM (DIAGNOSTICS)

Step	Check	Yes	No
4 CHECK STOP LIGHT & BRAKE SWITCH CIRCUIT. 1) Turn the ignition switch to OFF. 2) Disconnect the harness connector of ECM. 3) Measure the resistance between ECM harness connector terminal and stop light & brake switch harness connector terminal. Connector & terminal (B136) No. 3 — (B65) No. 3: (B136) No. 15 — (B65) No. 1:	Is the resistance less than 10 Ω ?	Replace the ECM. <Ref. to FU(H4SO)-39, Engine Control Module (ECM).> <Ref. to FU(H4DOTC)-57, Engine Control Module (ECM).> <Ref. to FU(H6DO)-50, Engine Control Module (ECM).>	Repair the harness.

Diagnostic Procedure with Cancel Code

CRUISE CONTROL SYSTEM (DIAGNOSTICS)

C: 13

Detected when clutch pedal is depressed or malfunction related to clutch switch occurs.

TROUBLE SYMPTOM:

- Cruise control cannot be set.
- Cruise control cannot be released.

WIRING DIAGRAM:

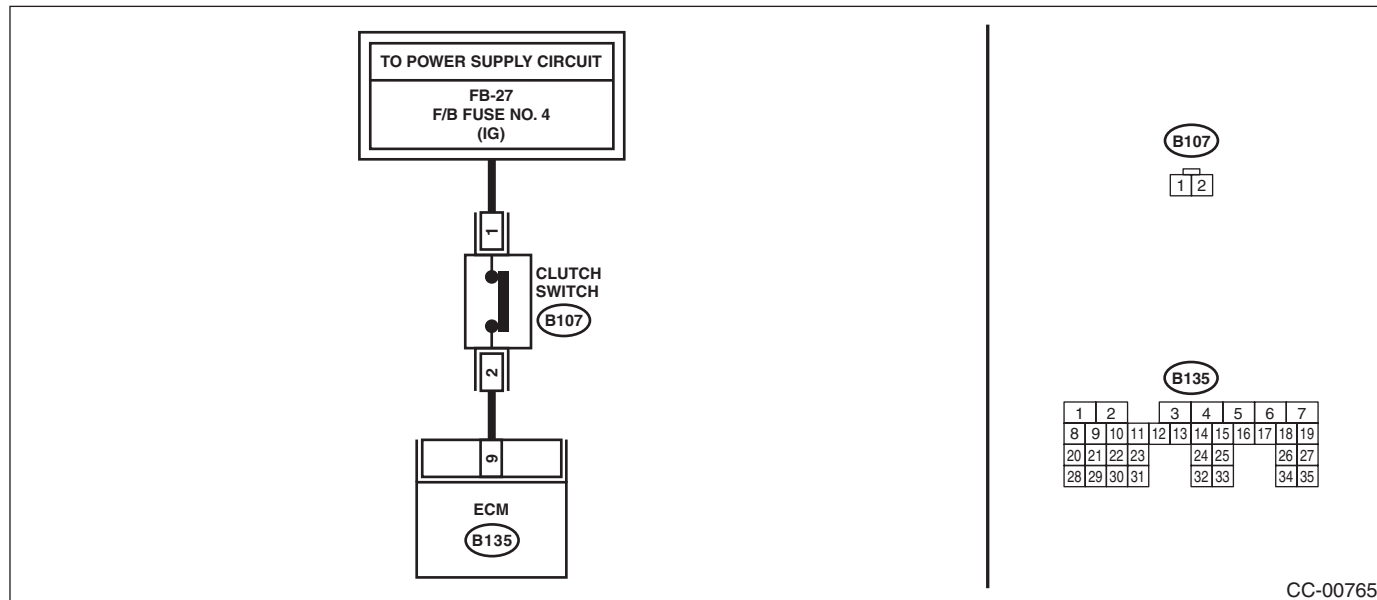

CC-00765

Step	Check	Yes	No
1	CHECK CLUTCH SWITCH. Check the clutch switch. <Ref. to CC-13, Clutch Switch.>	Go to step 2.	Replace the clutch switch. Or adjust the installation position.
2	CHECK CLUTCH SWITCH CIRCUIT. 1) Turn the ignition switch to OFF. 2) Disconnect the clutch switch harness connector. 3) Turn the ignition switch to ON. 4) Measure the voltage between harness connector terminal and chassis ground. Connector & terminal (B107) No. 1 (+) — Chassis ground (-):	Go to step 3.	<ul style="list-style-type: none"> • Check fuse No. 4 (in fuse & relay box). • Check open or short circuit of harness between clutch switch and fuse & relay box.
3	CHECK CLUTCH SWITCH CIRCUIT. 1) Turn the ignition switch to OFF. 2) Disconnect the harness connector of ECM. 3) Measure the resistance between clutch switch harness connector terminal and ECM harness connector terminal. Connector & terminal (B107) No. 2 — (B135) No. 9:	Replace the ECM. <Ref. to FU(H4SO)-39, Engine Control Module (ECM).> <Ref. to FU(H4DOTC)-57, Engine Control Module (ECM).> <Ref. to FU(H6DO)-50, Engine Control Module (ECM).>	Repair the harness.

Diagnostic Procedure with Cancel Code

CRUISE CONTROL SYSTEM (DIAGNOSTICS)

D: 14

Detected when select lever is set in the neutral position, or when malfunction related to neutral position switch occurs.

TROUBLE SYMPTOM:

Cruise control cannot be set.

WIRING DIAGRAM:

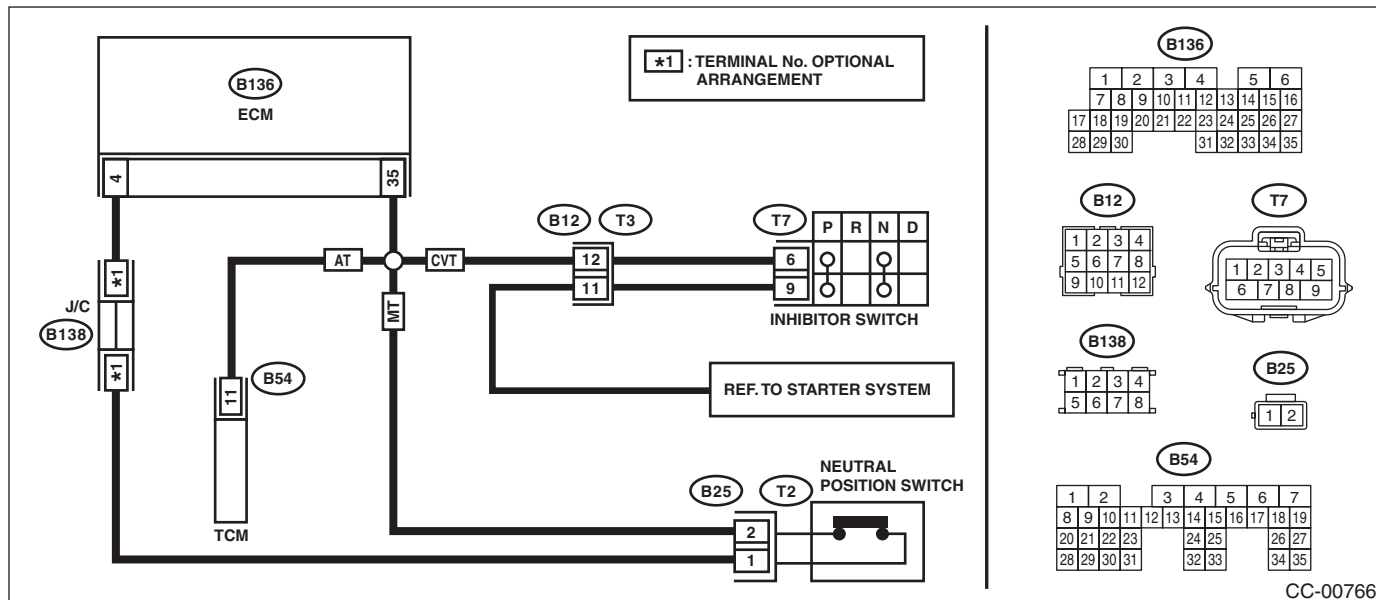

Step	Check	Yes	No
1	CHECK SPECIFICATIONS OF CHECKED VEHICLE. Check the vehicle destination and specification.	Is the vehicle 5AT model?	Go to step 2. / Go to step 5.
2	CHECK NEUTRAL POSITION SWITCH SIGNAL. 1) Connect the Subaru Select Monitor to data link connector. 2) Turn the ignition switch to ON and run the Subaru Select Monitor. 3) Select {Engine Control System} from the main menu. 4) Then, select the {Current Data Display & Save}. 5) Shift the select lever to "P" or "N" range, and check the signal of the neutral position switch.	If the select lever is in the "P" or the "N" range, is the Subaru Select Monitor Display ON? Or, if in a range other than "P" or "N", is the Subaru Select Monitor display OFF?	Replace the ECM. <Ref. to FU(H4DOTC)-57, Engine Control Module (ECM).> <Ref. to FU(H6DO)-50, Engine Control Module (ECM).> Go to step 3.
3	CHECK TCM OUTPUT VOLTAGE. 1) Turn the ignition switch to ON. 2) Measure the voltage between TCM harness connector terminal and chassis ground. Connector & terminal (B54) No. 11 (+) — Chassis ground (-):	If the select lever is in a range other than "P" or "N" ranges, is the voltage 10V or more? Or, if in "P" or "N", is the voltage less than 1V?	Go to step 4. / Check the TCM. <Ref. to 5AT (diag)-2, Basic Diagnostic Procedure.>
4	CHECK HARNESS BETWEEN TCM AND ECM. 1) Turn the ignition switch to OFF. 2) Disconnect the harness connector from TCM and ECM. 3) Measure the resistance between TCM harness connector terminal and ECM harness connector terminal. Connector & terminal (B136) No. 35 — (B54) No. 11:	Is the resistance less than 10 Ω?	Replace the ECM. <Ref. to FU(H4DOTC)-57, Engine Control Module (ECM).> <Ref. to FU(H6DO)-50, Engine Control Module (ECM).> Repair the wiring harness.

Diagnostic Procedure with Cancel Code

CRUISE CONTROL SYSTEM (DIAGNOSTICS)

Step	Check	Yes	No	
5	CHECK TRANSMISSION TYPE.	Is the transmission type CVT?	Go to step 6.	Go to step 9.(MT model)
6	CHECK INHIBITOR SWITCH CIRCUIT. 1) Turn the ignition switch to OFF. 2) Disconnect the inhibitor switch harness connector. 3) Turn the ignition switch to ON. 4) Measure the voltage between harness connector terminal and chassis ground. Connector & terminal (T7) No. 6 (+) — Chassis ground (-):	Is the voltage 10 V or more?	Go to step 7.	Check for open or short circuit in the harness between inhibitor switch and ECM.
7	CHECK INHIBITOR SWITCH CIRCUIT. 1) Turn the ignition switch to OFF. 2) Disconnect the starter motor harness connector. 3) Measure the resistance between inhibitor switch harness connector terminal and starter motor. Connector & terminal (T7) No. 9 — Starter motor:	Is the resistance less than 10 Ω ?	Go to step 8.	Repair the harness.
8	CHECK INHIBITOR SWITCH. Remove and check the inhibitor switch. <Ref. to CC-14, Inhibitor Switch.>	Is the inhibitor switch OK?	Replace the ECM. <Ref. to FU(H4SO)-39, Engine Control Module (ECM).>	Replace the inhibitor switch.
9	CHECK NEUTRAL POSITION SWITCH CIRCUIT. 1) Turn the ignition switch to OFF. 2) Disconnect the neutral position switch harness connector. 3) Turn the ignition switch to ON. 4) Measure the voltage between harness connector terminal and chassis ground. Connector & terminal (B25) No. 2 (+) — Chassis ground (-):	Is the voltage 10 V or more?	Go to step 10.	Check for open or short circuit in the harness between neutral position switch and ECM.
10	CHECK NEUTRAL POSITION SWITCH CIRCUIT. 1) Turn the ignition switch to OFF. 2) Measure resistance between harness connector terminal of neutral position switch and chassis ground. Connector & terminal (B25) No. 1 — Chassis ground:	Is the resistance less than 10 Ω ?	Go to step 11.	Repair the harness.
11	CHECK NEUTRAL POSITION SWITCH. Remove and check the neutral position switch. <Ref. to CC-16, Neutral Position Switch.>	Is the neutral position switch OK?	Replace the ECM. <Ref. to FU(H4SO)-39, Engine Control Module (ECM).> <Ref. to FU(H4DOTC)-57, Engine Control Module (ECM).>	Replace the neutral position switch.

Diagnostic Procedure with Cancel Code

CRUISE CONTROL SYSTEM (DIAGNOSTICS)

E: 15

Detected when CANCEL switch is pressed or malfunction related to CRUISE switch occurs.

TROUBLE SYMPTOM:

- Cruise control cannot be set. (Cancelled immediately.)
- Cruise control cannot be released.

Refer to DTC 11 for diagnostic procedure.

<Ref. to CC(diag)-16, 11, Diagnostic Procedure with Cancel Code.>

Diagnostic Procedure with Cancel Code

CRUISE CONTROL SYSTEM (DIAGNOSTICS)

F: 16

Detected when ignition switch is turned to OFF or malfunction related to the ignition switch occurs.

TROUBLE SYMPTOM:

Cruise control cannot be set.

WIRING DIAGRAM:

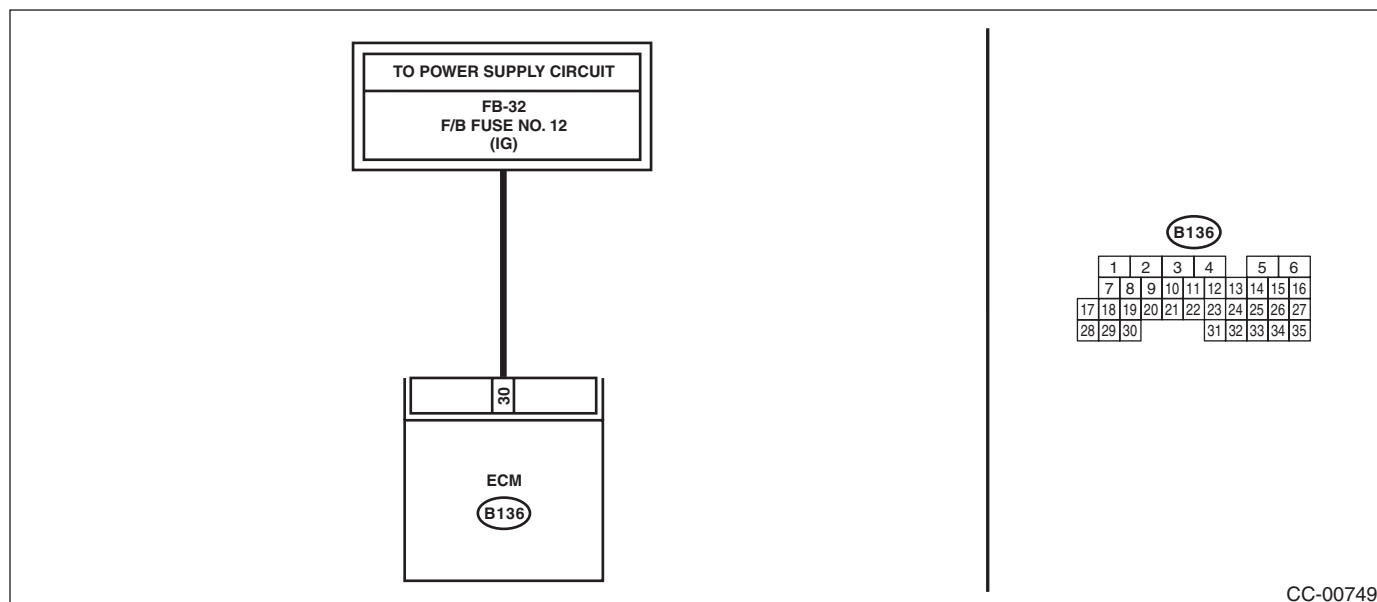

Step	Check	Yes	No
1 CHECK IGNITION SWITCH CIRCUIT. 1) Turn the ignition switch to OFF. 2) Disconnect the ECM harness connector. 3) Turn the ignition switch to ON. 4) Measure the voltage between harness connector terminal and chassis ground. Connector & terminal (B136) No. 30 (+) — Chassis ground (-):	Is the voltage 10 V or more?	Check for poor contact of ECM connector.	<ul style="list-style-type: none"> Check fuse No. 12 (in fuse & relay box). Check the harness for open or short circuit between ignition switch and ECM.

G: 21

Cruise control command switch malfunction is detected.

TROUBLE SYMPTOM:

- Cruise control cannot be set. (Cancelled immediately.)
- Cruise control cannot be released.

Refer to DTC 11 for diagnostic procedure.

<Ref. to CC(diag)-16, 11, Diagnostic Procedure with Cancel Code.>

Diagnostic Procedure with Cancel Code

CRUISE CONTROL SYSTEM (DIAGNOSTICS)

H: 22

Malfunction related to vehicle speed sensor is detected.

DIAGNOSIS:

Open or shorted circuit in vehicle speed sensor system.

TROUBLE SYMPTOM:

Cruise control cannot be set. (Cancelled immediately.)

	Step	Check	Yes	No
1	CHECK ABS OR VDC WARNING LIGHT. 1) Turn the ignition switch to ON. 2) After the initial operation of combination meter is completed, check if ABS or VDC warning light continues to illuminate.	Does the warning light continue to illuminate?	Check the VDCCM. <Ref. to VDC(diag)-2, Basic Diagnostic Procedure.>	Go to step 2.
2	CHECK DTC OF LAN COMMUNICATION CIRCUIT. Read the DTC of body integrated unit using Subaru Select Monitor.	Is DTC displayed?	Perform inspection according to DTC.	Replace the ECM. <Ref. to FU(H4SO)-39, Engine Control Module (ECM).> <Ref. to FU(H4DOTC)-57, Engine Control Module (ECM).> <Ref. to FU(H6DO)-50, Engine Control Module (ECM).>

I: 24

Malfunction in cruise control-related switch is detected.

TROUBLE SYMPTOM:

- Cruise control cannot be set. (Cancelled immediately.)
- Cruise control cannot be released.

Refer to DTC 11 for diagnostic procedure.

<Ref. to CC(diag)-16, 11, Diagnostic Procedure with Cancel Code.>

J: 25

Malfunction of brake input circuit in ECM is detected.

Refer to the Engine Diagnostic Procedure for diagnostic procedure.

<Ref. to EN(H4SO)(diag)-2, PROCEDURE, Basic Diagnostic Procedure.>

<Ref. to EN(H4DOTC)(diag)-2, PROCEDURE, Basic Diagnostic Procedure.>

<Ref. to EN(H6DO)(diag)-2, PROCEDURE, Basic Diagnostic Procedure.>

K: 31

Engine speed signal malfunction is detected.

Abnormal increase of engine speed is detected.

Gear is placed in 1st or Reverse position.

After driving at the 2nd gear position or higher, perform the cruise setting again. If a cancel code is not detected, it is normal.

L: 32

This DTC is detected out of vehicle speed range.

Increase vehicle speed high enough to allow the cruise control to function, and then perform setting operation again.

If cancel code is still detected after setting cruise again, perform the diagnosis for DTC 22.

Refer to DTC 22 for diagnostic procedure.

<Ref. to CC(diag)-25, 22, Diagnostic Procedure with Cancel Code.>

Diagnostic Procedure with Cancel Code

CRUISE CONTROL SYSTEM (DIAGNOSTICS)

M: 34

The vehicle has been driven at a speed higher than set speed for a long time (approximately 10 minutes) during cruise driving.

This cancel code is detected when driving for a long period of time at a speed higher than appropriate for cruise control setting by operating the accelerator pedal.

Perform the cruise control setting operation again. If the cancel code is not detected, it is normal.

N: 35

Detected when it is impossible to perform the vehicle speed feedback.

Set vehicle speed cannot be kept for some reasons (steep uphill, unreleased parking brake, etc.) during cruise driving.

Cancel code is detected when driving conditions are not suitable for cruise control.

Perform cruise set operation again after clearing the possible cause.

O: 41

VDC/TCS has operated.

Vehicle dynamics control (VDC) or TCS is operated during cruise driving or cruise setting.

<Ref. to VDC(diag)-2, PROCEDURE, Basic Diagnostic Procedure.>

P: 43

Malfunction of ABS/VDC is detected.

VDC malfunction is detected during cruise driving or cruise setting.

<Ref. to VDC(diag)-2, PROCEDURE, Basic Diagnostic Procedure.>

Q: 44

Body integrated unit malfunction is detected.

Body integrated unit system malfunction is detected during cruise driving or cruise setting.

<Ref. to LAN(diag)-2, PROCEDURE, Basic Diagnostic Procedure.>

R: 45

Malfunction of the combination meter is detected.

Combination meter malfunction is detected during cruise driving or cruise setting.

<Ref. to LAN(diag)-2, PROCEDURE, Basic Diagnostic Procedure.>

S: 49

Automatic transmission malfunction is detected.

Automatic transmission malfunction is detected during cruise driving or cruise setting. <Ref. to 5AT(diag)-2, PROCEDURE, Basic Diagnostic Procedure.> <Ref. to CVT(diag)-2, PROCEDURE, Basic Diagnostic Procedure.>

T: 61

Malfunction in the stop light & brake switch is detected.

TROUBLE SYMPTOM:

- Cruise control cannot be set.
- Cruise control cannot be released.

Refer to DTC 12 for diagnostic procedure.

<Ref. to CC(diag)-18, 12, Diagnostic Procedure with Cancel Code.>

U: 62

Neutral position switch malfunction is detected.

TROUBLE SYMPTOM:

Cruise control cannot be set.

Refer to DTC 14 for diagnostic procedure.

<Ref. to CC(diag)-21, 14, Diagnostic Procedure with Cancel Code.>

Diagnostic Procedure with Cancel Code

CRUISE CONTROL SYSTEM (DIAGNOSTICS)

V: 63

Malfunction of vehicle speed signal variation is detected.

TROUBLE SYMPTOM:

Cruise control cannot be set. (Cancelled immediately.)

Refer to DTC 22 for diagnostic procedure.

<Ref. to CC(diag)-25, 22, Diagnostic Procedure with Cancel Code.>

W: 64

Malfunction related to engine is detected.

Refer to the Engine Diagnostic Procedure for diagnostic procedure.

<Ref. to EN(H4SO)(diag)-2, PROCEDURE, Basic Diagnostic Procedure.>

<Ref. to EN(H4DOTC)(diag)-2, PROCEDURE, Basic Diagnostic Procedure.>

<Ref. to EN(H6DO)(diag)-2, PROCEDURE, Basic Diagnostic Procedure.>

X: 65

Cruise control command switch malfunction is detected.

While the command switch is pressed ON for a long time (approximately two minutes), stuck ON condition is detected.

TROUBLE SYMPTOM:

- Cruise control cannot be set. (Cancelled immediately.)
- Cruise control cannot be released.

Refer to DTC 11 for diagnostic procedure.

<Ref. to CC(diag)-16, 11, Diagnostic Procedure with Cancel Code.>

Y: 66

Cruise control processing malfunction is detected.

Refer to the Engine Diagnostic Procedure for diagnostic procedure.

<Ref. to EN(H4SO)(diag)-2, PROCEDURE, Basic Diagnostic Procedure.>

<Ref. to EN(H4DOTC)(diag)-2, PROCEDURE, Basic Diagnostic Procedure.>

<Ref. to EN(H6DO)(diag)-2, PROCEDURE, Basic Diagnostic Procedure.>

Diagnostic Procedure with Cancel Code

CRUISE CONTROL SYSTEM (DIAGNOSTICS)
