

Rear Door Latch and Door Lock Actuator Assembly

SECURITY AND LOCKS

11. Rear Door Latch and Door Lock Actuator Assembly

A: REMOVAL

- 1) Disconnect the ground cable from battery.
- 2) Remove the rear door trim. <Ref. to EI-60, REMOVAL, Door Trim.>
- 3) Remove the sealing cover.

CAUTION:

- Carefully remove the butyl tape. Excessive force will easily break the cover.
- If the sealing cover gets broken, replace it with a new part.

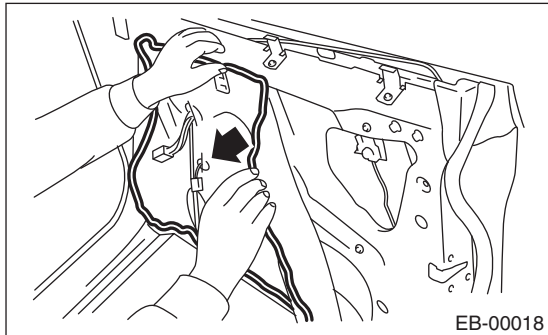

- 4) Remove the rear door glass. <Ref. to GW-32, REMOVAL, Rear Door Glass.>
- 5) Remove the rear door latch and door lock actuator assembly.
 - (1) Disconnect the connector.
 - (2) Remove the screws, and remove the rear door latch & door lock actuator assembly.

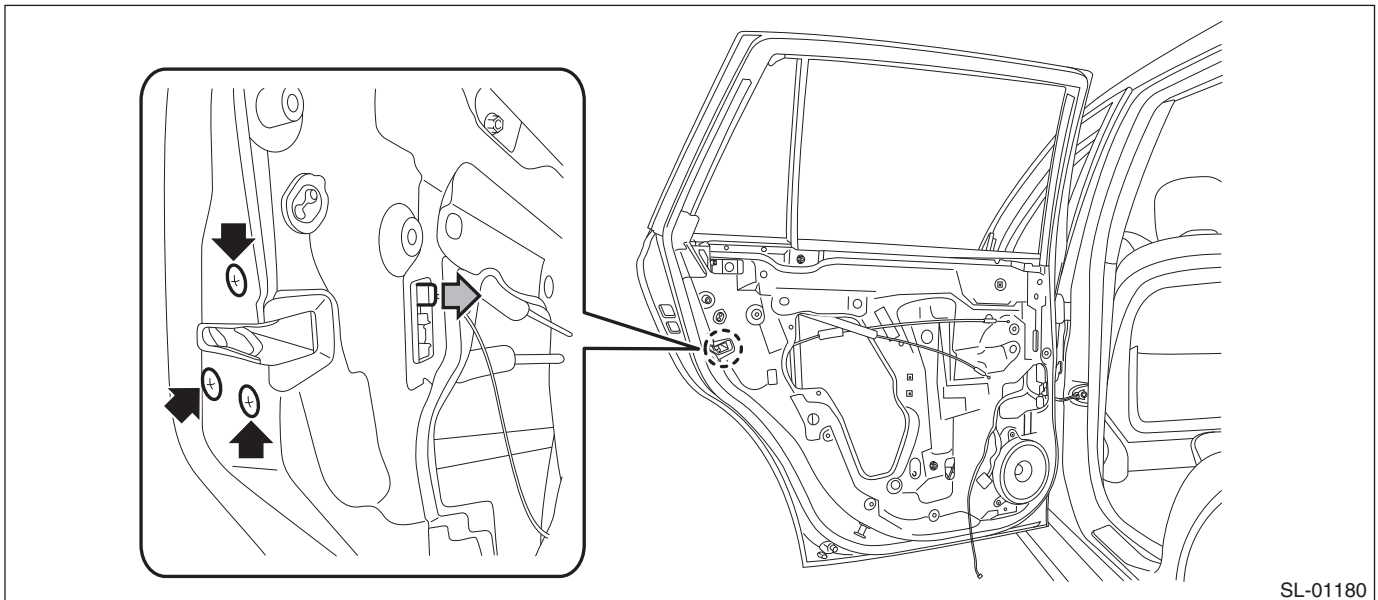

B: INSTALLATION

- 1) Before installation, check the following items.
 - Cable and rod are free from deformation.
 - Grease is applied sufficiently to rod joints.If grease is insufficient, add it as necessary before assembling the rod.
- 2) Install each part in the reverse order of removal.

Tightening torque:

Refer to "COMPONENT" of "General Description". <Ref. to SL-2, DOOR LOCK ASSEMBLY, COMPONENT, General Description.>

NOTE:

After installation, make sure that the child safety lock works correctly.

C: INSPECTION

1. REAR DOOR LATCH

Check if the rear door latch operates normally.

If the cable or rod is faulty, replace the front door latch & door lock actuator assembly.

2. REAR DOOR LOCK ACTUATOR

1) Disconnect the rear door lock actuator connector.

2) Check the door lock operation by applying battery voltage between the terminals of rear door lock actuator.

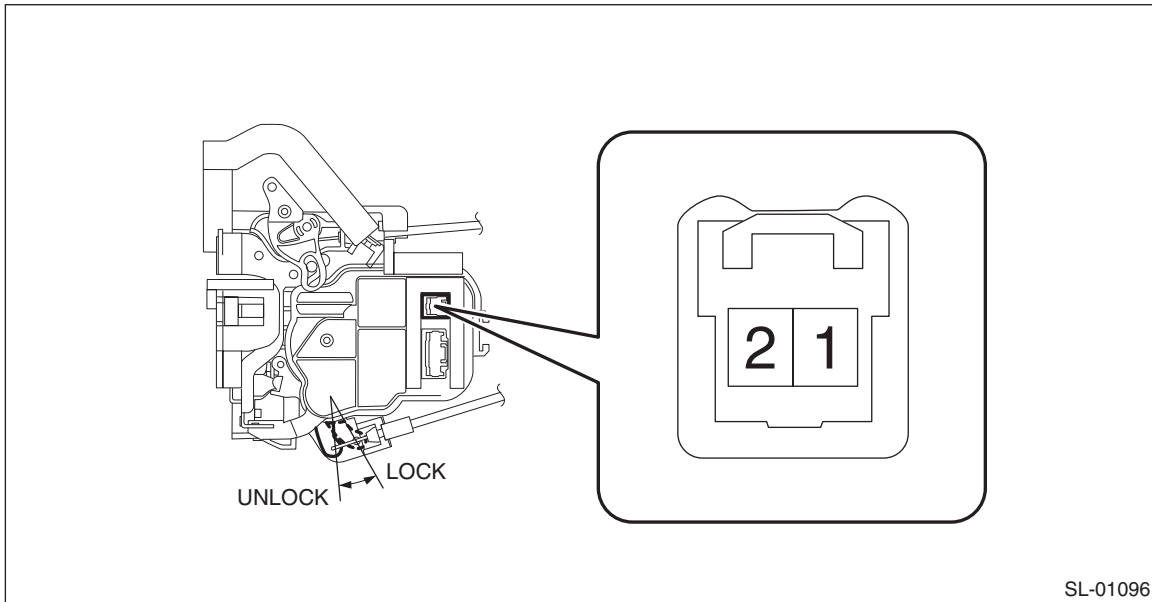

SL-01096

Inspection conditions	Terminal No.	
	1	2
LOCK → UNLOCK	-	+
UNLOCK → LOCK	+	-

3) If the actuator does not operate normally, replace the rear door latch & door lock actuator assembly.