

Rear Gate Latch and Actuator Assembly

SECURITY AND LOCKS

14.Rear Gate Latch and Actuator Assembly

A: REMOVAL

- 1) Disconnect the ground cable from battery.
- 2) Remove the rear gate trim. <Ref. to EI-157, REMOVAL, Rear Gate Trim.>
- 3) Remove the rear gate latch & actuator assembly.
 - (1) Remove the bolts and pull out the rear gate latch & actuator assembly to the vehicle front.
 - (2) Disconnect the connectors, and then remove the rear gate latch & actuator assembly.

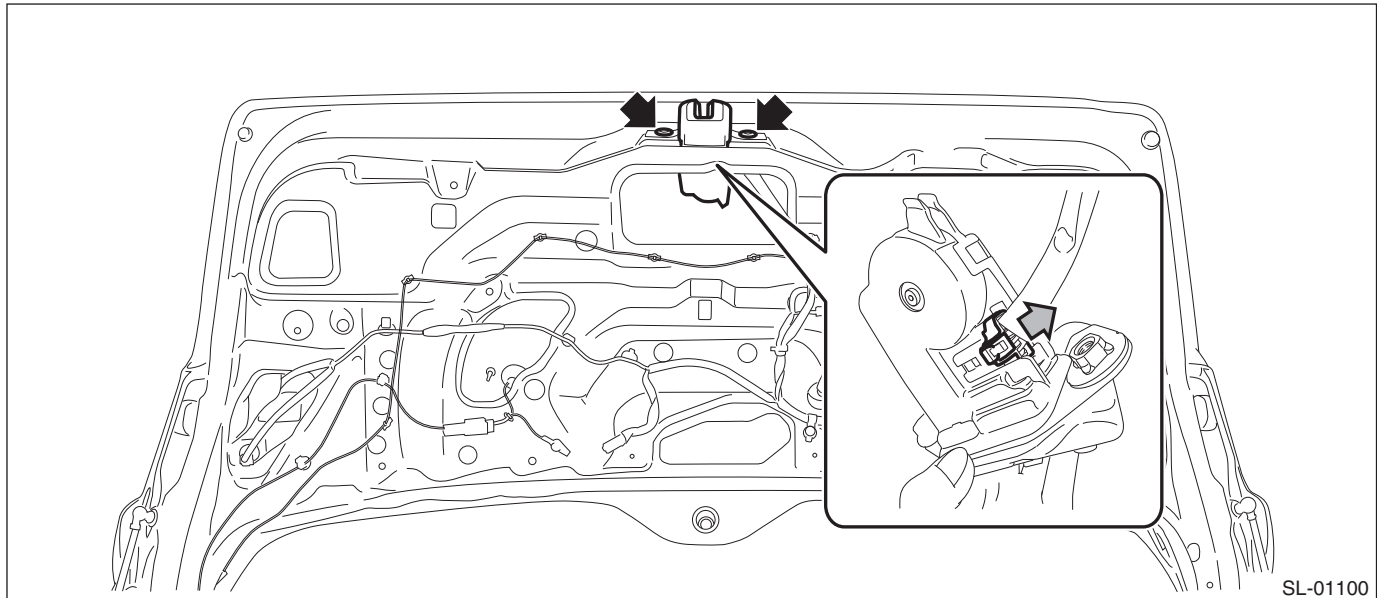

B: INSTALLATION

Install each part in the reverse order of removal.

Tightening torque:

Refer to "COMPONENT" of "General Description". <Ref. to SL-3, REAR GATE LOCK AND TRUNK LID LOCK, COMPONENT, General Description.>

C: INSPECTION

1. REAR GATE LATCH

Check if the rear gate latch operates normally.

- If latch deformation, abnormal wear, or unsmooth lock operation is observed, replace the rear gate latch & actuator assembly.

2. LOCK ACTUATOR

- 1) Disconnect the rear gate latch & actuator assembly connector.
- 2) Check the door lock operation by applying battery voltage between the terminals of rear gate latch & actuator.

Preparation tool: Circuit tester

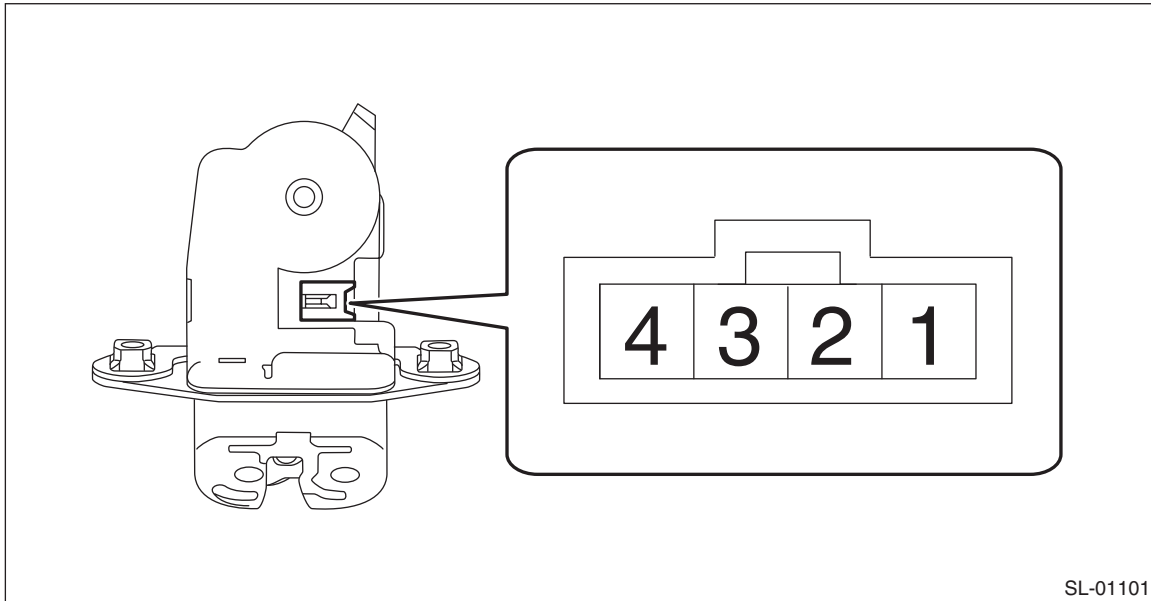

Inspection conditions	Terminal No.	
	LOCK → UNLOCK	1
	+	-

- 3) If the actuator does not operate normally, replace the rear gate latch & actuator assembly.