

## 17.Remote Openers

### A: REMOVAL

#### 1. FRONT HOOD OPENER

- 1) Remove the opener lever.
  - (1) Remove the cable.
  - (2) Remove the nut, and detach the opener lever.

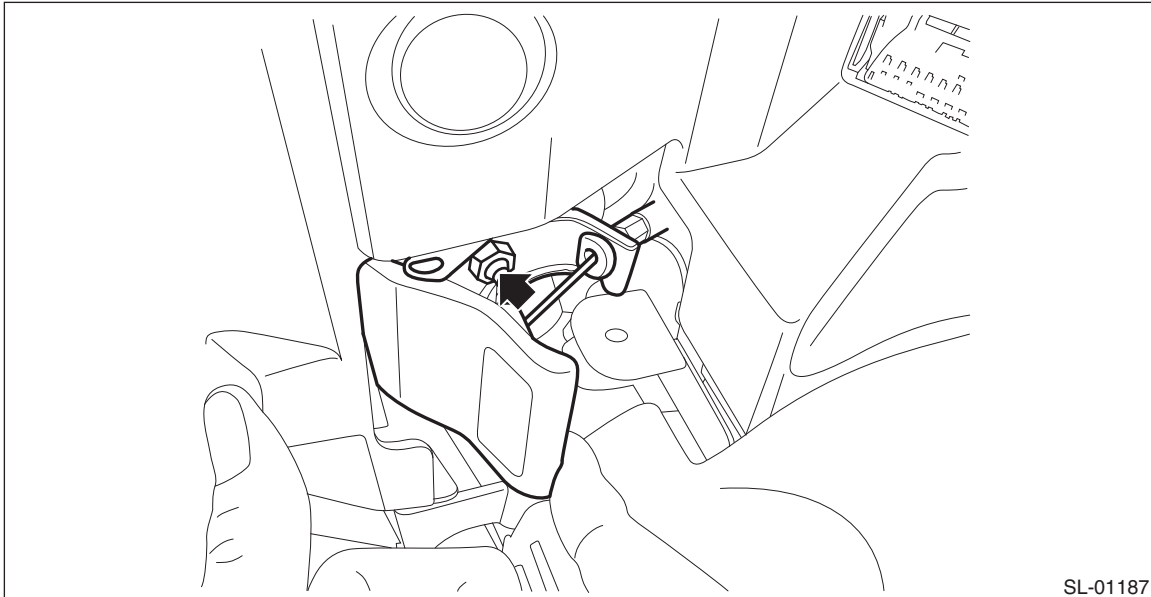

- 2) Remove the following parts and remove the cable clip and cable.
  - Front hood lock ASSY:<Ref. to SL-52, REMOVAL, Front Hood Lock Assembly.>
  - Instrument panel lower cover:<Ref. to EI-63, REMOVAL, Instrument Panel Lower Cover.>

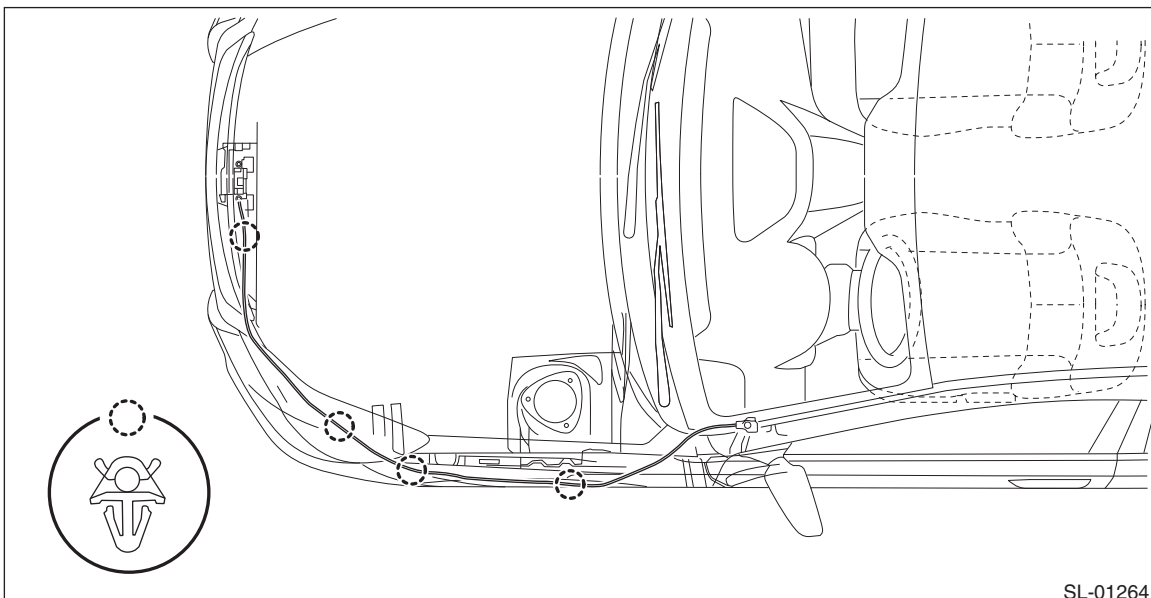

# Remote Openers

## SECURITY AND LOCKS

### 2. FUEL FLAP OPENER

- 1) Remove the pull handle cover.
  - (1) Open the cover by using a flat tip screwdriver.
  - (2) Remove the screw and remove the pull handle cover.

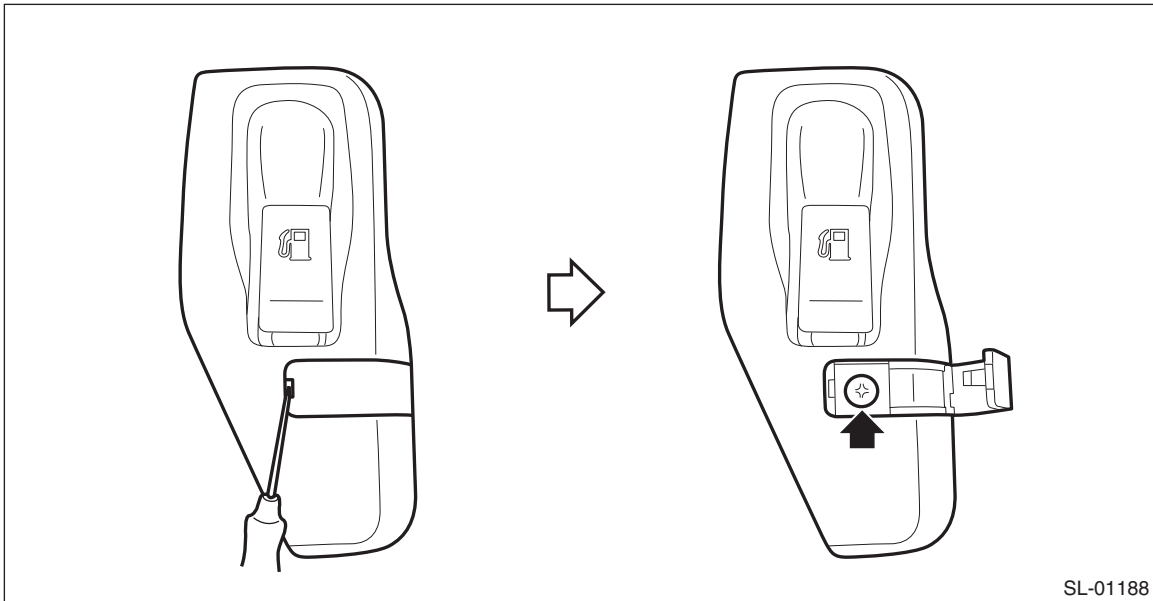

- 2) Remove the opener handle.
  - (1) Remove the nuts.
  - (2) Remove the cable from opener pull handle.

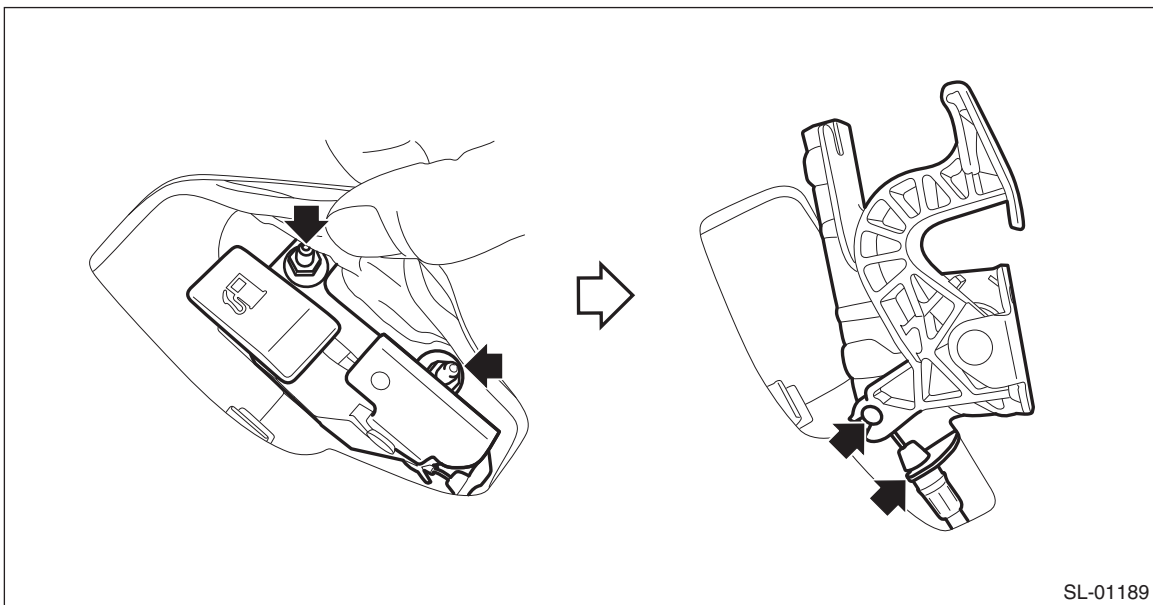

- 3) Remove the rear quarter trim RH. (OUTBACK model) <Ref. to EI-114, OUTBACK MODEL, REMOVAL, Rear Quarter Trim.>
- 4) Remove the trunk room trim (RH). (Sedan model) <Ref. to EI-127, TRUNK ROOM TRIM, REMOVAL, Trunk Room Trim.>
- 5) Remove the fuel lock inside the quarter panel.
  - (1) Press the claws of the fuel lock.

(2) While keeping the condition in step (1), pull the fuel lock to the rearward of the vehicle.

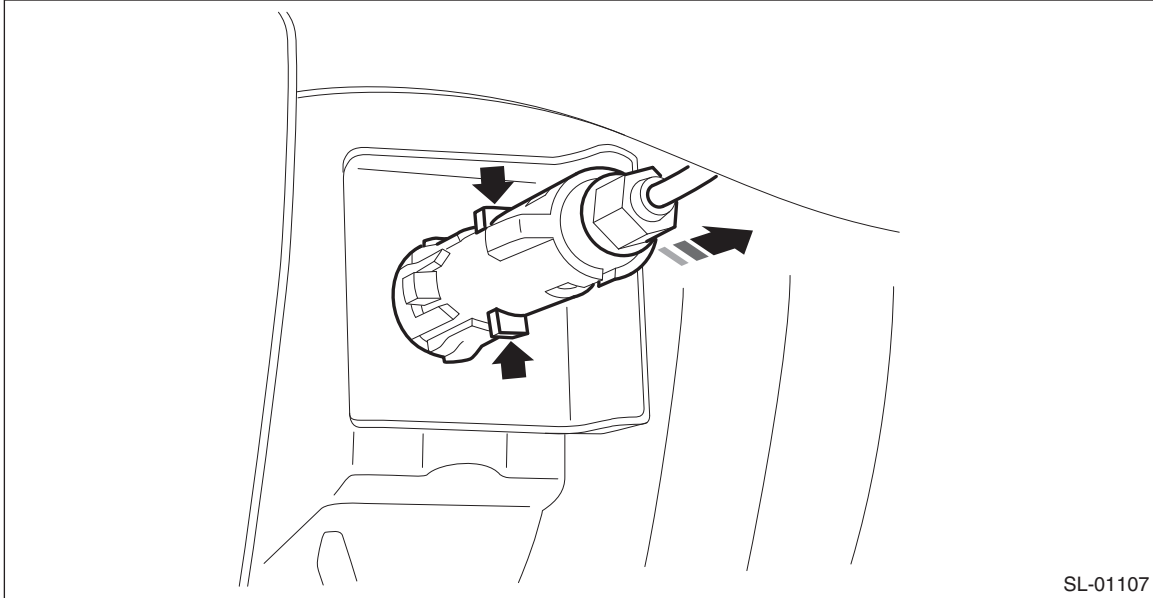

SL-01107

6) Remove the lower inner trim. <Ref. to EI-95, REMOVAL, Lower Inner Trim.>

7) Remove the cable clip, and remove the cable.

- Sedan model

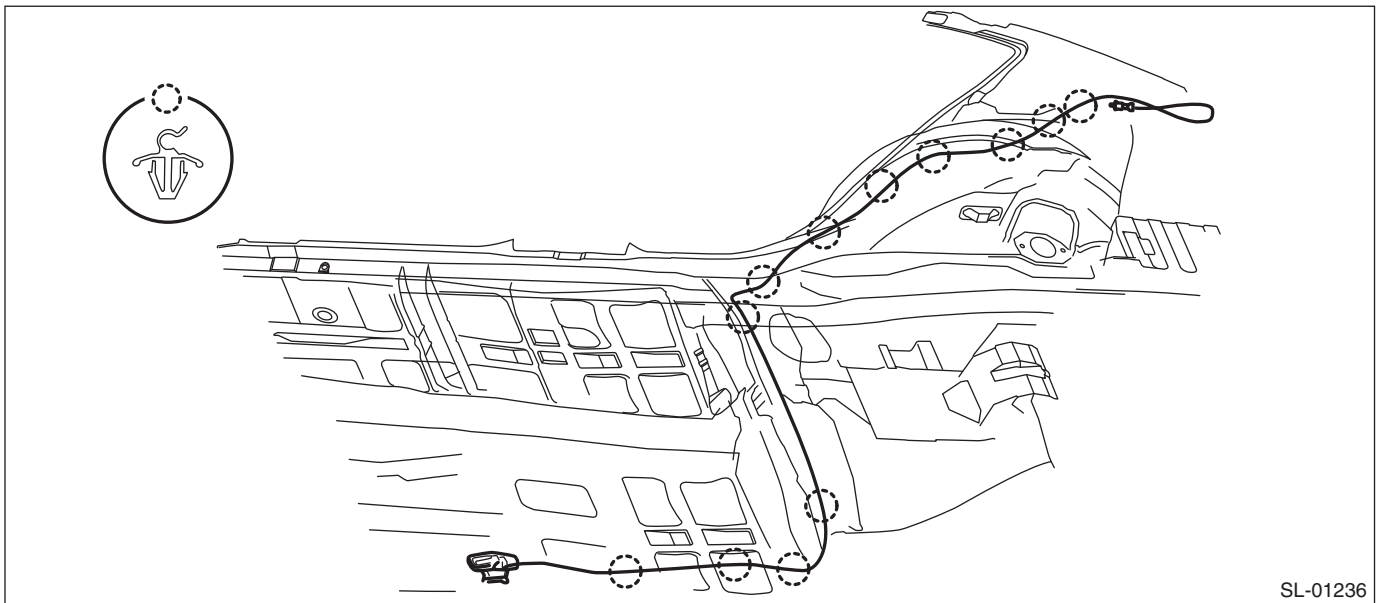

SL-01236

# Remote Openers

## SECURITY AND LOCKS

- OUTBACK model

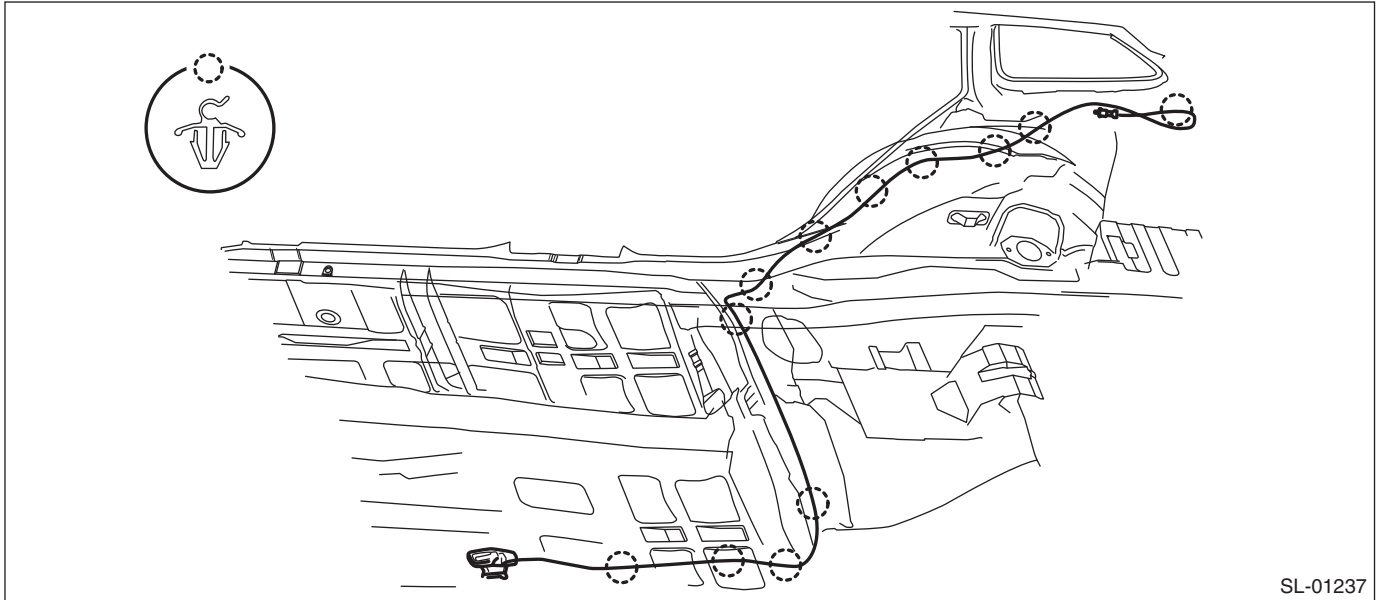

### B: INSTALLATION

- 1) Before installation, check the following items.
  - Cable is free from deformation such as fray.
- 2) Install each part in the reverse order of removal.

#### **Tightening torque:**

*Refer to "COMPONENT" of "General Description". <Ref. to SL-4, FRONT HOOD LOCK AND REMOTE OPENERS, COMPONENT, General Description.>*

### C: INSPECTION

Check if the front hood and fuel flap operate normally.