

Roof Molding

EXTERIOR/INTERIOR TRIM

12. Roof Molding

A: REMOVAL

CAUTION:

Be careful not to damage the body.

- 1) Remove the roof rail assembly. (OUTBACK model) <Ref. to EI-59, REMOVAL, Roof Rail.>
- 2) Turn over the front end of roof molding.
- 3) Using a flat tip screwdriver, slide the internal clip in the direction of arrow.

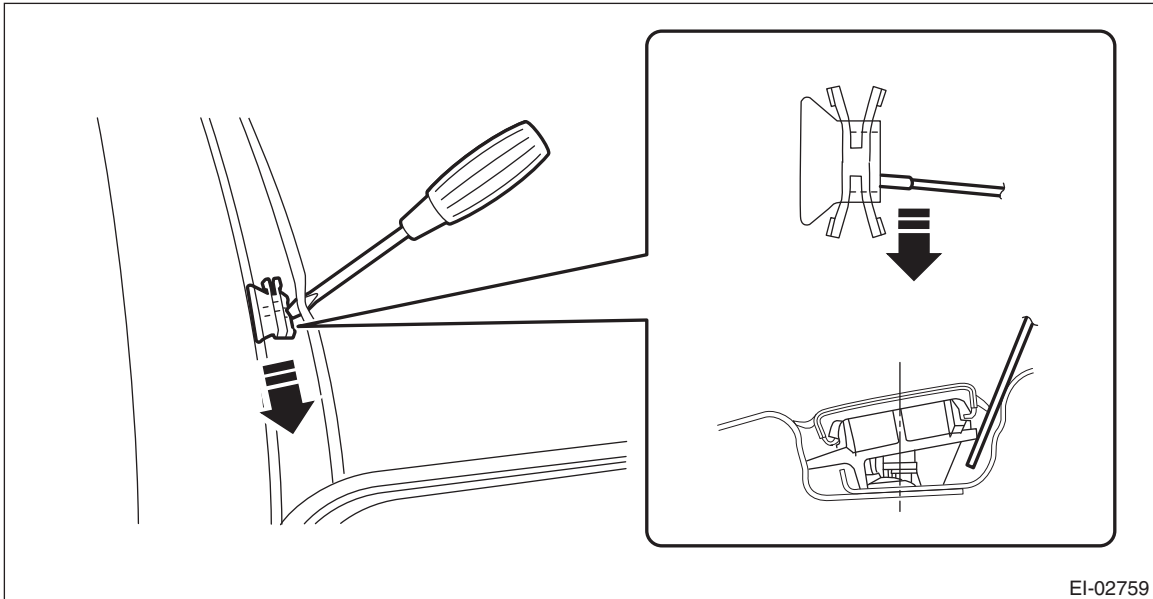

Right: Slide toward vehicle front.

Left: Slide toward vehicle rear.

- 4) Remove the clip from the stud on the body by sliding it.

- Sedan model: 6 clips per side

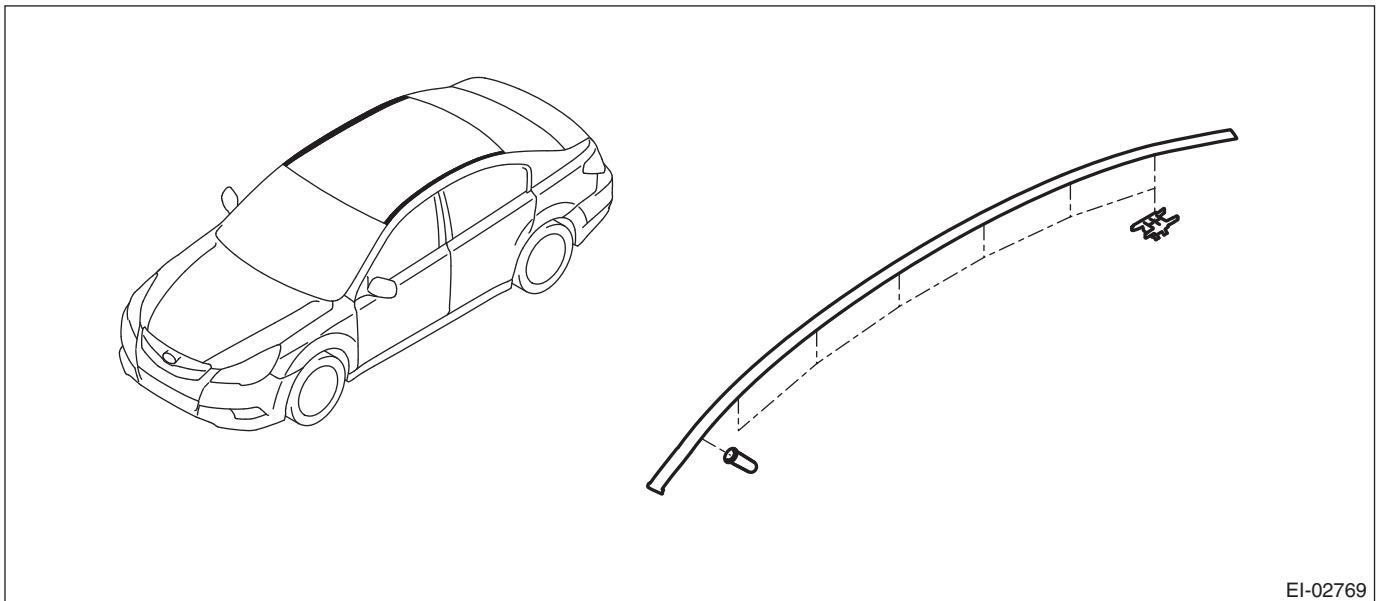

- OUTBACK model: 1 clip per side

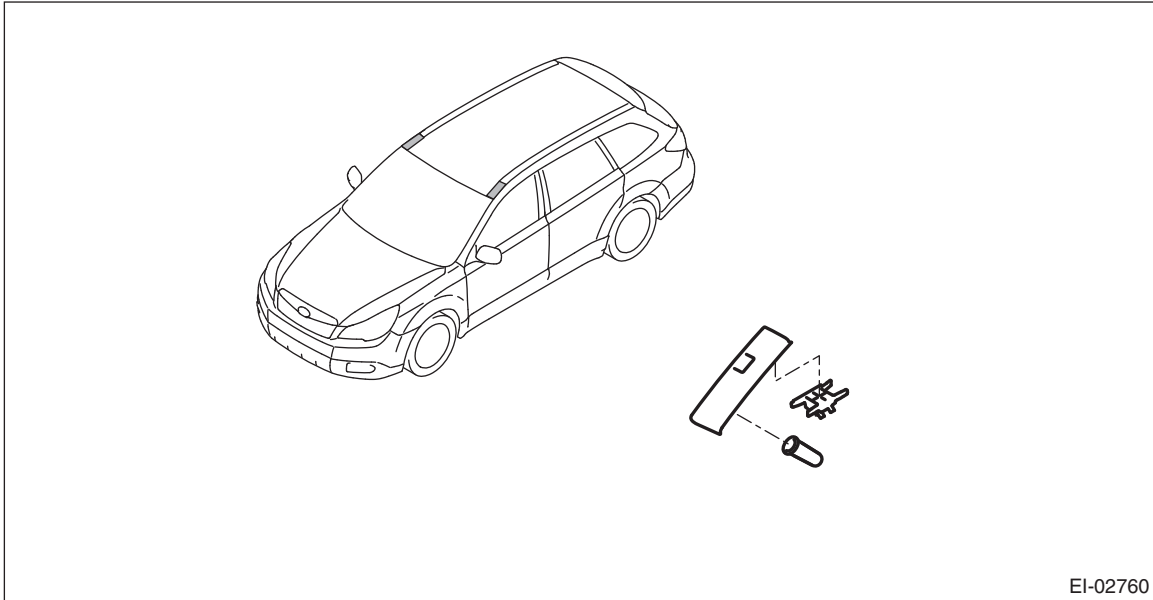

5) Remove the roof molding from the vehicle body by pulling it upward.

B: INSTALLATION

1) Remove the clips from the roof molding and attach them on the stud on body.

CAUTION:

- Any clips damaged during roof molding removal must be replaced with new parts.
- While installing the roof molding, be careful not to catch the glass molding with the tip of the front side and rear side.

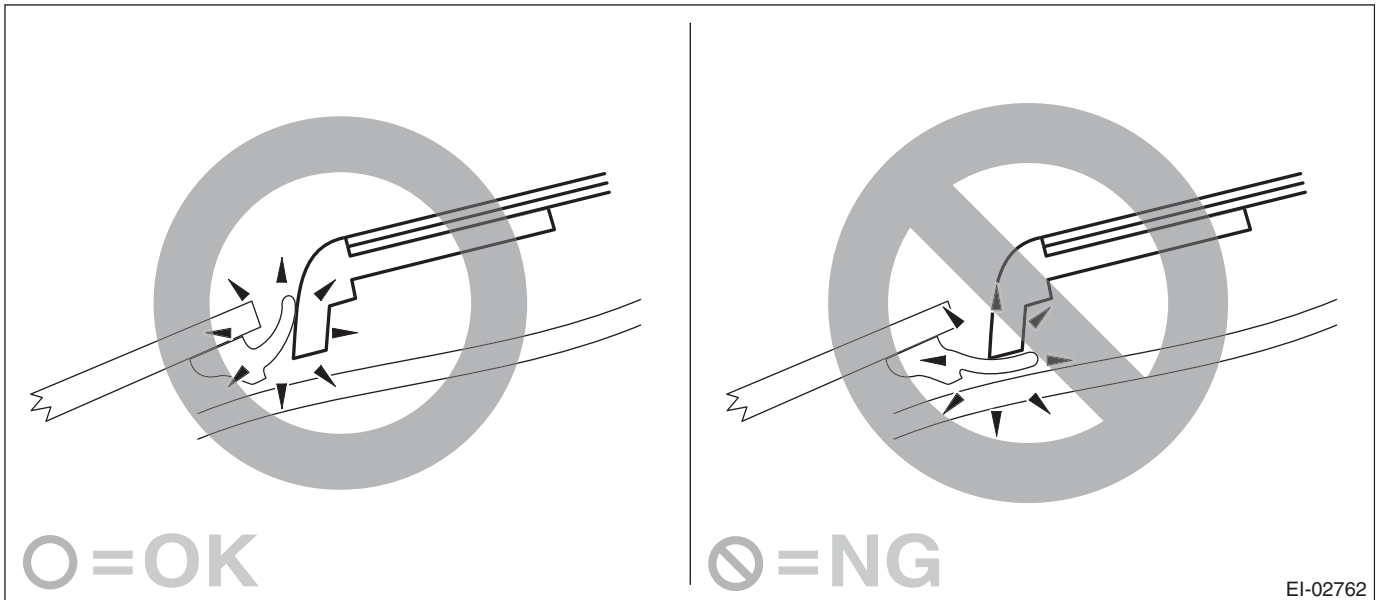

Roof Molding

EXTERIOR/INTERIOR TRIM

2) Apply the front end of roof molding to the front window, and attach the front positioning clip to the rivet on body.

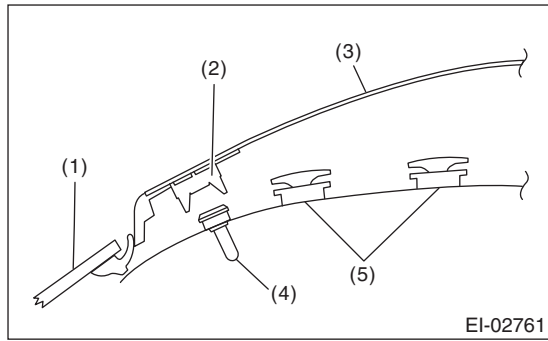

- (1) Windshield
- (2) Positioning clip
- (3) Roof molding
- (4) Rivet
- (5) Clip

3) While pressing the roof molding from above, connect the roof molding with clips.