

Mud Guard

EXTERIOR/INTERIOR TRIM

8. Mud Guard

A: REMOVAL

- 1) Lift up the vehicle.
- 2) Remove the wheels.
- 3) Remove the clips, and remove the mud guard.

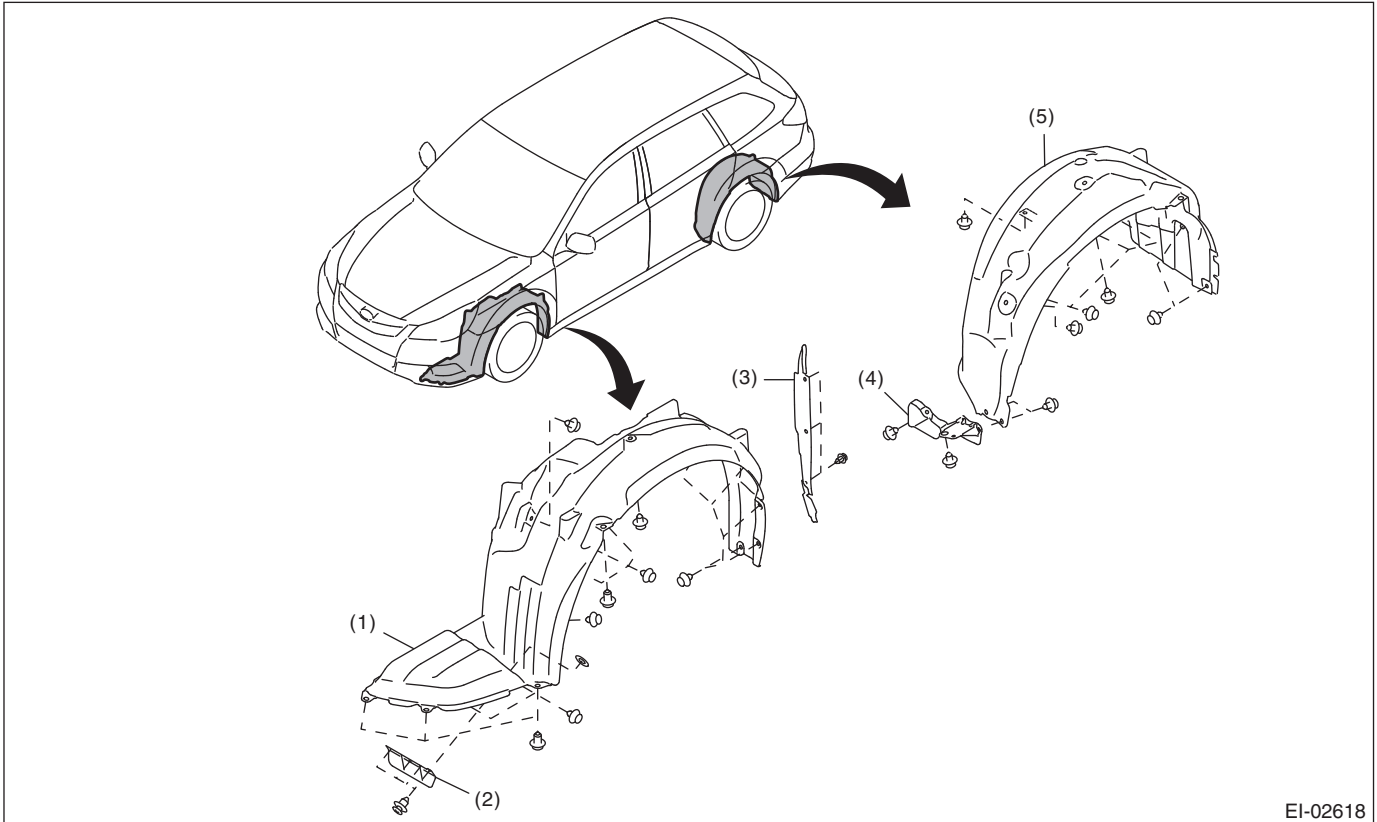

- (1) Front mud guard
(2) Front air flap plate

- (3) Fender cover lower
(4) Rear air flap plate

- (5) Rear mud guard

B: INSTALLATION

Install each part in the reverse order of removal.

Tightening torque:

Wheel nut: 120 N·m (12.2 kgf-m, 88.5 ft-lb)