

Back-up Light System

WIRING SYSTEM

10. Back-up Light System

A: WIRING DIAGRAM

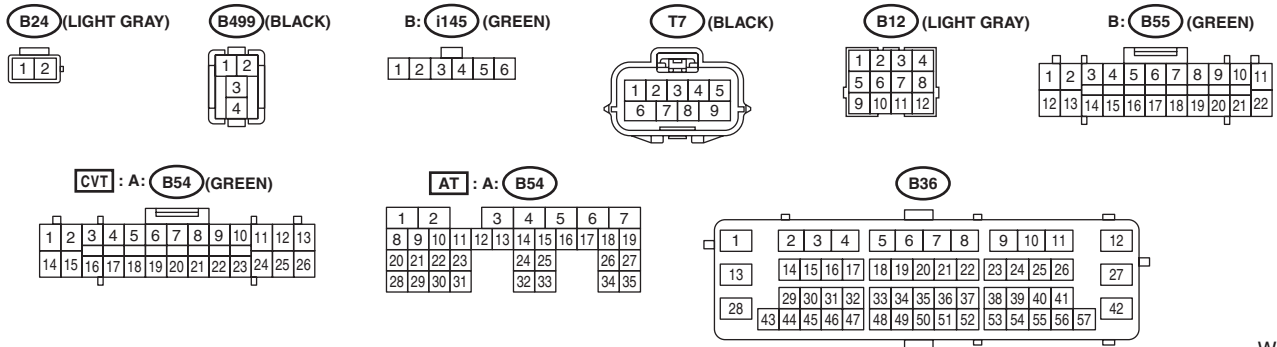
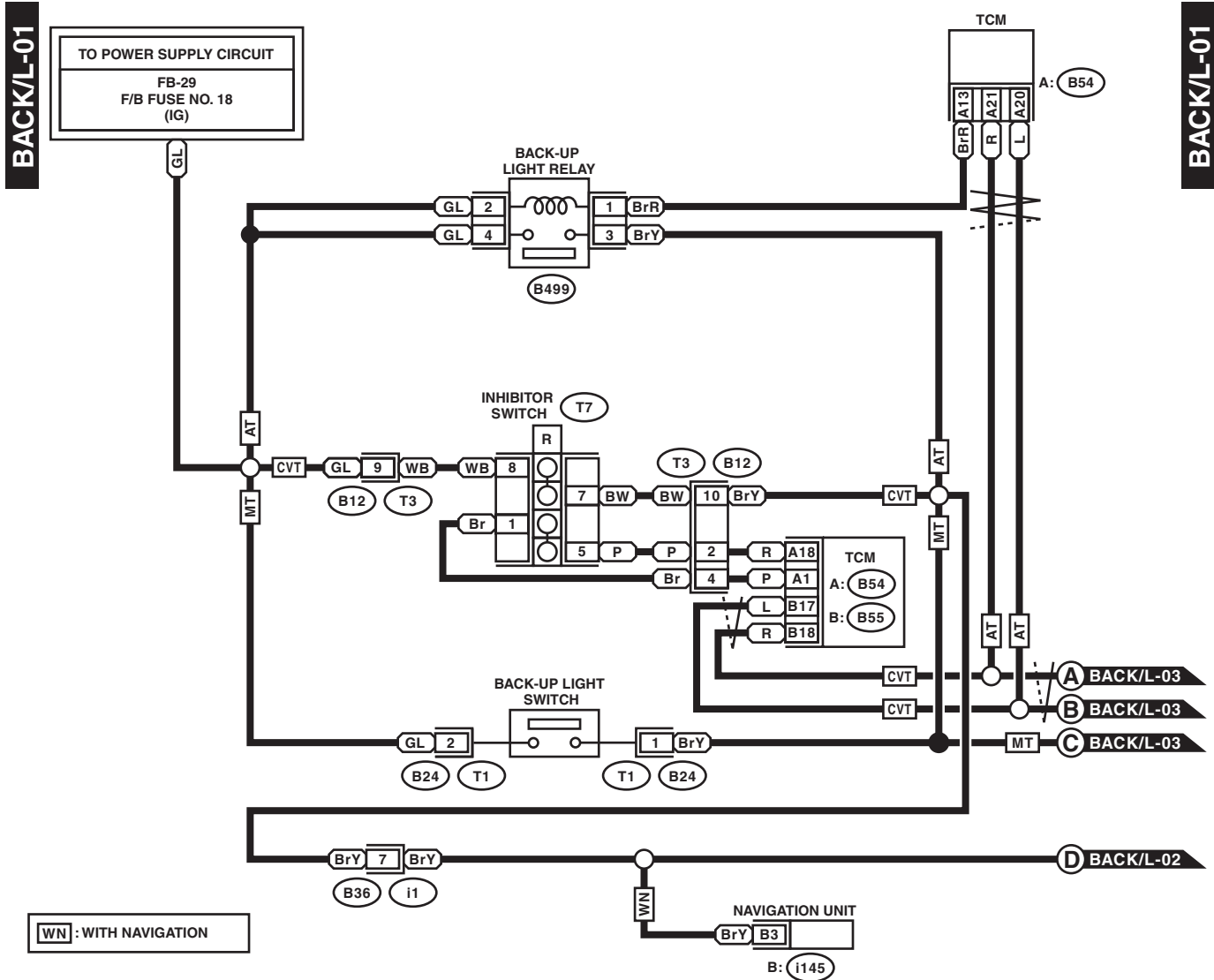

WI-25442

Back-up Light System

WIRING SYSTEM

BACK/L-03

BACK/L-03

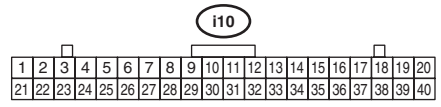
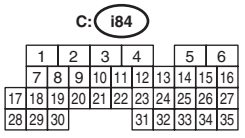
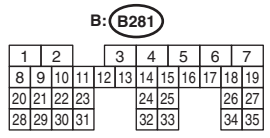
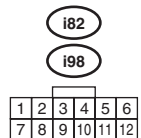
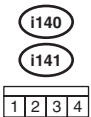
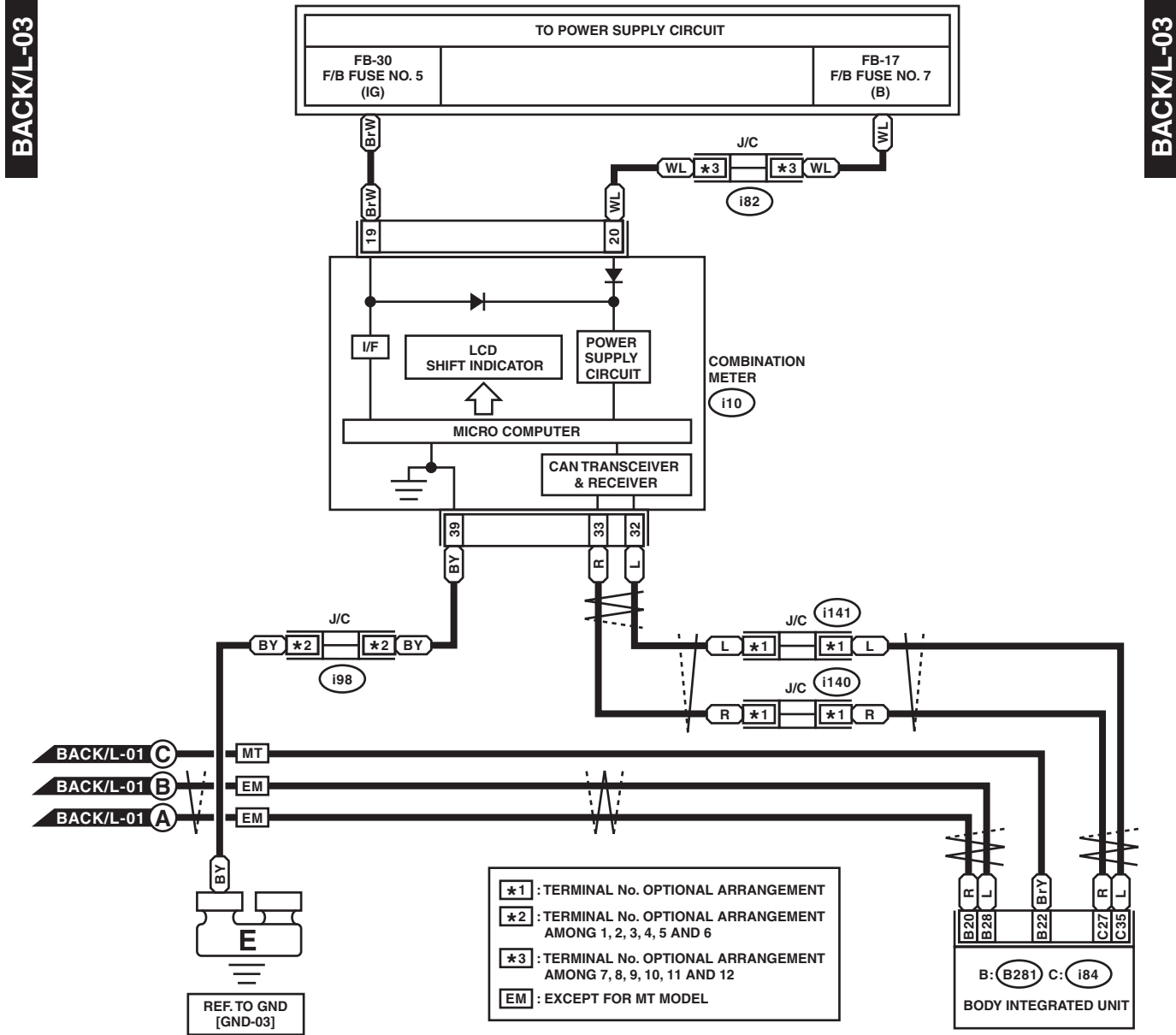

WI-25444