

Pre-delivery Inspection

PRE-DELIVERY INSPECTION

1. Pre-delivery Inspection

A: GENERAL DESCRIPTION

The purposes of the pre-delivery inspection (PDI) are as follows.

- Remove the additional parts used for ensuring the vehicle quality during transportation and restore the vehicle to its normal condition.
- Check the vehicle before delivery is in normal condition.
- Check the vehicle has no damage and no vehicle protective parts are missing while shipped or stored in a car barn.
- Make sure to deliver a complete vehicle to customer.

For above reasons, all SOA service center must carry out the PDIs before delivery of vehicle.

Besides, all SOA service center and PDI center check the condition of all vehicles to make sure to take responsibility.

B: PRE-DELIVERY INSPECTION (PDI) PROCEDURE

Static Checks Just after Vehicle Receipt

Operation	Check point
1. Appearance	<ol style="list-style-type: none">1. If the vehicle is covered with protective coating, visually check the vehicle body for damage and dents. If the protective coating has been removed, visually check the painted body surfaces in detail for damage or rust.2. Visually check the glass and light lenses for any damage, cracks or excessive gaps between body sheet metal.3. Visually check the plated parts for any damage.4. Check the instrument panel, console and trim for stains or dirt.
2. Tire	<ol style="list-style-type: none">1. Check the tires for damage, defective, and dents on wheels.2. Check the tire air pressure.
3. Fuses	If the vehicle is about to be delivered to customer, attach a back-up fuse.
4. Lock/unlock and open/close operation checks of doors.	<ol style="list-style-type: none">1. Using the key, check the door can be locked or unlocked normally.2. Open and close all doors to check that there are no problems.3. Operate the power door lock switch to check that all doors and the rear gate lock and unlock normally.
5. Child safety lock	Check the child safety lock system operates normally.
6. Trunk lid open/close operations	<ol style="list-style-type: none">1. Press the trunk opener switch for approx. one second to check for normal operation of the trunk lid.2. Check that main and sub keys can lock/unlock the release lever, and that valet key can not lock/unlock the release lever.3. Open and close the trunk lid to see that there are no abnormal conditions.
7. Operation check of trunk lid release lever	Operate the trunk lid release lever to check that the trunk lock is unlocked normally.
8. Rear gate lock/unlock and open/close operations	<ol style="list-style-type: none">1. Open and close the rear gate to check that there are no problems.2. Check if the rear gate can be unlocked normally through the emergency hole.3. Operate the power door lock switch to check that all doors and the rear gate lock and unlock normally.
9. Fuel lid opener lever	Operate the fuel lid opener to check that the fuel lid is unlocked normally.
10. Accessory	Check that the following accessories are provided. <ul style="list-style-type: none">• Owner's manual• Warranty booklet• Maintenance note• Spare key• Key number plate• Jack• Tool set• Spare tire• Towing hook (eyebolt (model with eyebolt))• Security ID plate (except for models with keyless access function)
11. Front hood lock release system	Operate the front hood lock release lever to check that the front hood opens normally.

Pre-delivery Inspection

PRE-DELIVERY INSPECTION

Operation	Check point
12. Battery	Check the battery for any abnormal conditions such as rust or traces of battery fluid leaks.
13. Brake fluid	Check the brake fluid amount.
14. Engine oil	Check the engine oil amount.
15. Transmission gear oil	Check that the transmission gear oil level is normal.
16. AT front differential gear oil	Check for leakage of AT front differential gear oil.
17. CVT front differential gear oil	Check for no leakage of CVT front differential gear oil.
18. Rear differential gear oil	Check for leakage of gear oil from the rear differential.
19. Engine coolant	Check the engine coolant level.
20. Clutch fluid	Check the clutch fluid amount.
21. Window washer fluid	Check the window washer fluid amount.
22. Front hood latch	Check that the front hood is closed normally and locked securely.
23. Keyless entry system	Check that the keyless entry system operates normally.
24. Keyless access function	Check that the keyless access function operates normally.
25. Security system (Alarm system)	Check that the security system (alarm system) operates normally.
26. Seat	<ol style="list-style-type: none">1. Check the seat surfaces for stains or dirt.2. Check the seat installation conditions and functionality.3. Check that the occupant detection system for passenger's seat operates normally.
27. Seat belt	<ol style="list-style-type: none">1. Check the seat belt installation conditions and functionality.2. Check the seat belt warning system operates normally.
28. TPMS (U.S. model)	<ol style="list-style-type: none">1. Turn the TPMS transmitter power supply to ON.2. If the display of TPMS warning light does not operate normally, perform the diagnosis by referring to TPMS (Diagnosis).

Pre-delivery Inspection

PRE-DELIVERY INSPECTION

Checks with the Engine Running

Operation	Check point
29. Immobilizer system	1. Check that the engine starts with all keys that are equipped on vehicle. 2. 60 seconds after turning ignition switch from ON to ACC or OFF, or immediately after removing the key, check that the security indicator light is blinking.
30. Starting condition	Start the engine and check that the engine starts smoothly.
31. Exhaust system	Check that the exhaust noise is normal and no leaks are found.
32. Indicator and warning lights	Check that all indicator lights and warning lights are operating correctly.
33. Heater & ventilation	Check that the heater & ventilation system operates normally.
34. Air conditioner	Check that the air conditioner operates normally.
35. Clock	1. Check that the clock operates normally. 2. Check for normal switch operation of fuel economy display.
36. Audio	1. Check that the audio system operates normally. 2. Check that the radio, CD and AUX systems operate normally.
37. Navigation system	1. Check all display functions for normal operation. 2. Check that the navigation, audio and AUX systems operate normally. 3. Check that the rearview camera operates normally.
38. Accessory power supply socket	Check that the accessory power supply socket operates normally.
39. Lighting system	Check that the lighting system operates normally.
40. Wiper deicer	Check that the wiper deicer operates normally.
41. Illumination control	Check that the illumination control operates normally.
42. Window washer	Check that the window washer system operates normally.
43. Wiper	Check that the wiper system operates normally.
44. Power window	Check that the power window operates normally.
45. Sunroof	Check that the sunroof operates normally.
46. Door mirror	Check that the remote control mirror and heated mirror operate normally.
47. Room mirror (EC and RCD models)	1. Check all display functions for normal operation. (RCD model) 2. Check that the automatic anti-glare function operates normally. (EC and RCD models) 3. Check that the rearview camera operates normally. (RCD model)
48. Rear defogger	Check that the rear defogger system operates normally.
49. Parking brake	Check the parking brake for normal operations.

Dynamic Test with the Vehicle Running

Operation	Check point
50. Brake test	Check the foot brake for normal operations.
51. AT, CVT shift control	Check that the AT, CVT shifts normally.
52. MT shift control	Check that the MT shifts normally.
53. Cruise control	Check that the cruise control system operates normally.
54. Subaru EyeSight	Check that the Subaru EyeSight operates normally.

Checks after Dynamic Test

Operation	Check point
55. ATF level	Check that the ATF level is correct.
56. Power steering fluid level	Check that the power steering fluid level is normal.
57. Fluid leakage	Check for fluid/oil leaks.
58. Water leakage	Spray the vehicle with water and check for water leaks.
59. Appearance 2	1. Remove the protective coat. (If attached) 2. Check the body paints for damage and stain. 3. Check the plated parts for damage and rust.

1. APPEARANCE

- If the vehicle is covered with protective coating, visually check the vehicle body for damage and dents.
- When the protective coating is removed, visually check the body paints for damage or stains in detail and repair as necessary.
- Visually check the windshield glass, door glasses and light lenses for any damage, cracks or excessive gaps to the body sheet metal and repair as necessary.
- Visually check the plated parts, such as the grilles and door knobs, for damage or loss of gloss and replace the parts as necessary.
- Check the instrument panel, console, and trims for stains or dirt.

2. TIRE

- Check the tires for damage, defective, and dents on wheels.
- Check and correct the tire size, spare tire and tire air pressure described on the tire air pressure label (driver's side).

3. FUSE

Backup fuse (20A) remains removed to prevent the battery consumption when vehicles are delivered. Install the backup fuse by following the illustration. Besides, removing the backup fuse from the fuse holder deactivates the control during shipping (delivery mode).

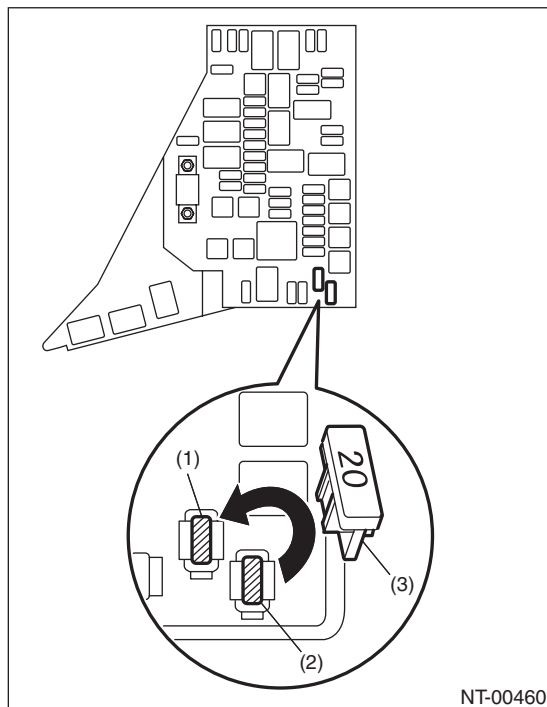

- (1) Backup fuse inlet
- (2) Backup fuse holder
- (3) Backup fuse

4. LOCK/UNLOCK AND OPEN/CLOSE OPERATION CHECKS OF DOORS

- 1) Using the key, lock and unlock the door several times to check for normal operation. Open and close the door several times for smooth movement.

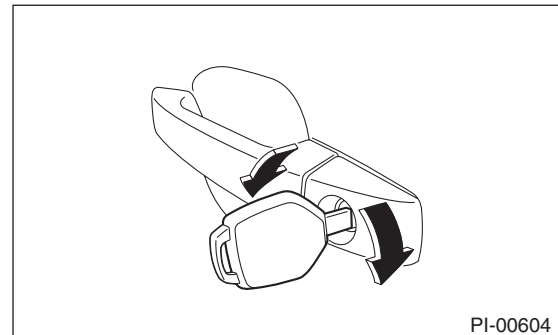

- 2) Completely close the driver's door, and then check the smooth movement with operating door lock knob from lock to unlock several times. Set the door lock knob (A) to lock position. Then pull the inner remote (B) to ensure that doors will not open. For other doors, place the door lock knob (A) to lock position and then pull the inner remote (B) to ensure that doors will not open.

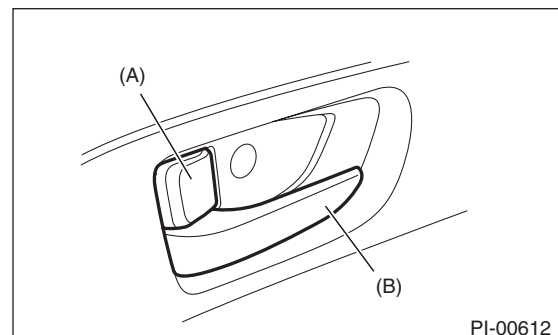

- (A) Door lock knob
- (B) Inner remote

- 3) Close all the doors, and then press the lock on power door lock switch at driver's side. Check that all doors including rear gate are locked.

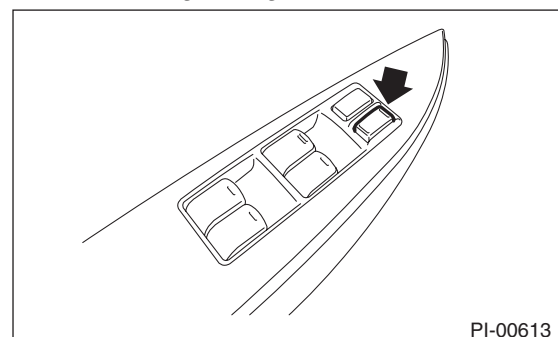

Pre-delivery Inspection

PRE-DELIVERY INSPECTION

4) Press the driver's side power door lock switch to unlock side. Check that all doors including rear gate are unlocked.

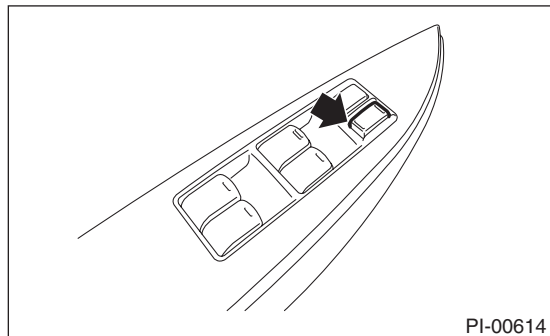

5) Check that the passenger's side power door lock switch locks and unlocks normally in the same manner.

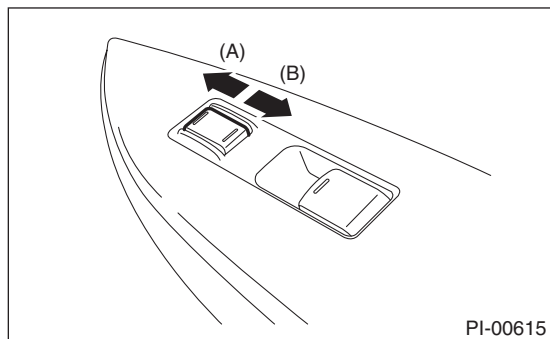

- (A) Lock
- (B) Unlock

6) Insert the key to ignition switch, and open the driver's side door. Press lock on power door lock. Check that the door is not locked.

5. CHILD SAFETY LOCK SYSTEM

- 1) Set the child safety lock on both rear doors to the lock position.
- 2) Close the rear doors completely.
- 3) Check that the lock levers of the rear doors are in the unlock position. Then, pull inner remote of rear doors to ensure that the doors will not open.

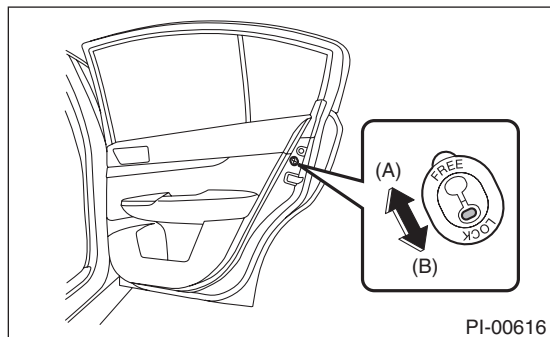

- (A) Unlock
- (B) Lock

4) Pull the outer handles of rear doors to ensure that the doors will open.

6. OPEN/CLOSE OPERATION CHECKS OF TRUNK LID

1) Press the trunk opener switch for approx. one second to check for normal operation of the trunk lid.

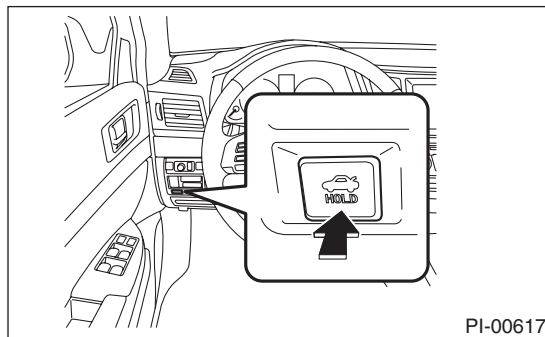

2) Open and close the trunk lid several times for smooth movement.

3) Press the trunk opener lock button in the glove box.

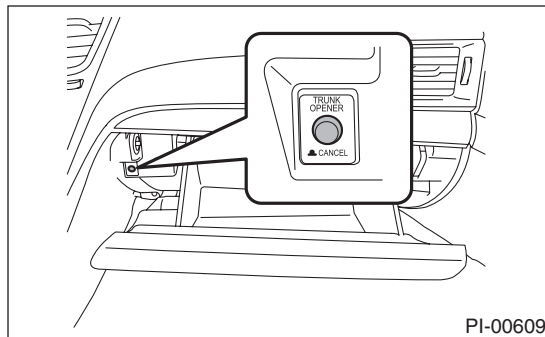

4) Check that the trunk lid will not open even when the trunk opener button is pressed.

7. TRUNK LID RELEASE HANDLE

CAUTION:

Do not check the trunk lid release handle when in the trunk. If the trunk lid release handle is defective, you may be trapped in.

1) Use a flat tip screwdriver. Slide in the screwdriver through the clearance at the lock assembly until a click sound is heard. This is the latch lock position.

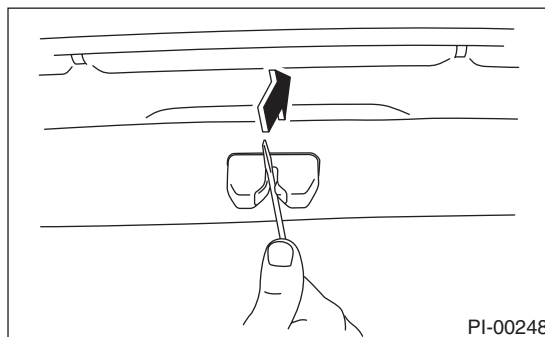

2) Make sure the latch is released by pulling the yellow trunk lid release handle in the direction of arrow.

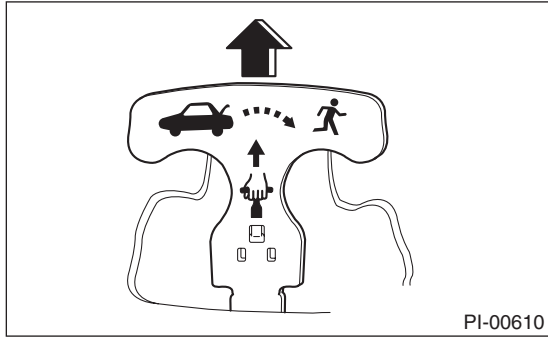

8. LOCK/UNLOCK AND OPEN/CLOSE OPERATIONS OF REAR GATE

1) Open and close the rear gate several times for smooth movement.

2) Operate the rear gate lever to check that the rear gate is locked and unlocked normally.

(1) Remove the cover inside the rear gate.

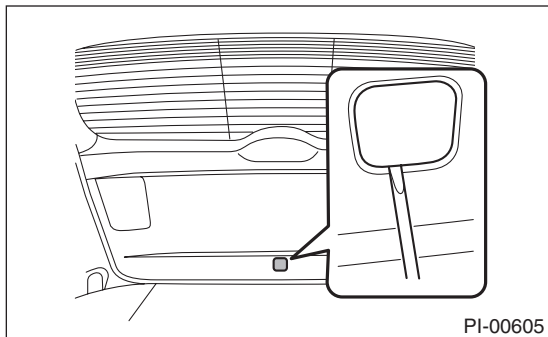

(2) Operate the lever to check that the rear gate is locked and unlocked normally.

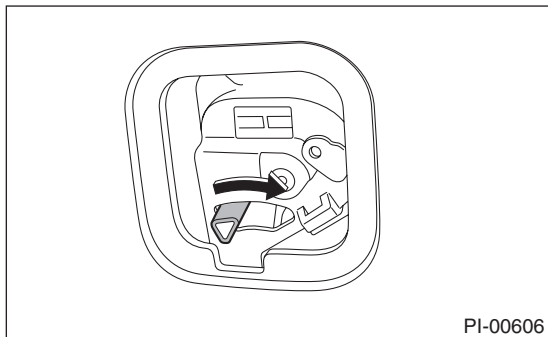

9. FUEL LID OPENER LEVER

Operate the fuel lid opener to check that the fuel lid is unlocked normally. Check that the filler cap is securely closed.

10. ACCESSORY

Check that the following accessories are provided.

- Owner's manual
- Warranty booklet
- Maintenance note
- Spare key
- Key number plate
- Jack
- Tool set
- Spare tire
- Towing hook (eyebolt (model with eyebolt))
- Security ID plate (except for models with keyless access function)
 - Sedan model

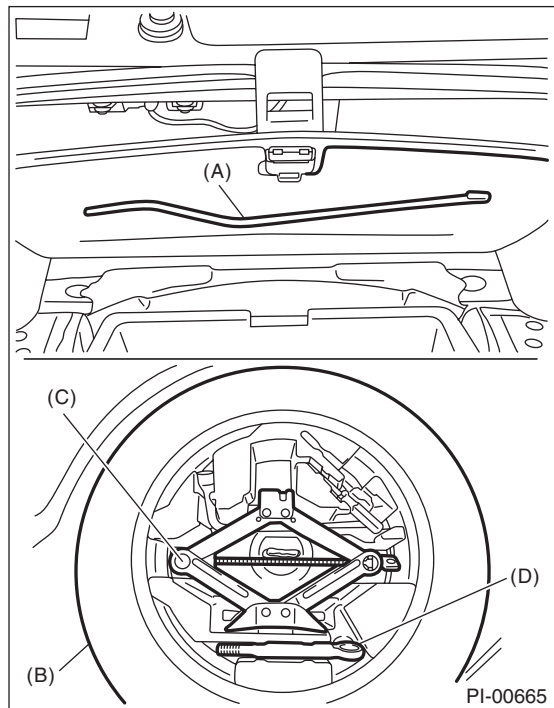

- (A) Jack handle
- (B) Spare tire
- (C) Jack
- (D) Towing hook (eyebolt)

Pre-delivery Inspection

PRE-DELIVERY INSPECTION

- Wagon model

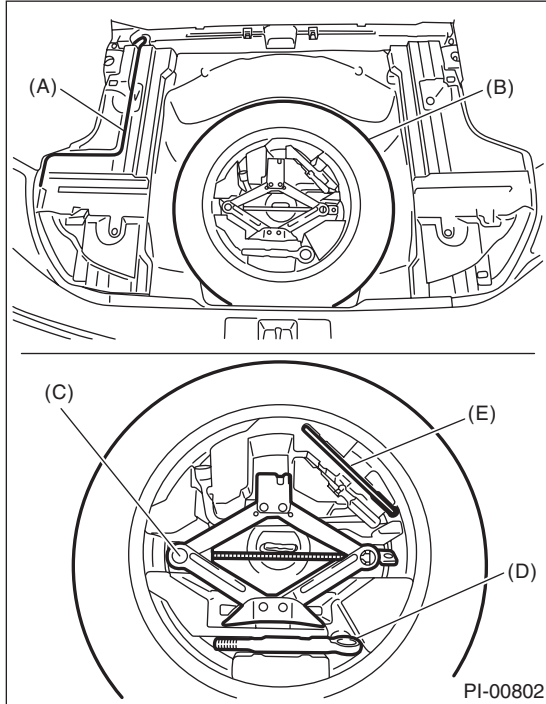

- (A) Jack handle
- (B) Spare tire
- (C) Jack
- (D) Towing hook (eyebolt)
- (E) Torque wrench (for roof rail adjustment)

11. OPERATION CHECK OF FRONT HOOD LOCK RELEASE SYSTEM

Operate the front hood lock release lever (A) to check that the front hood is unlocked normally.

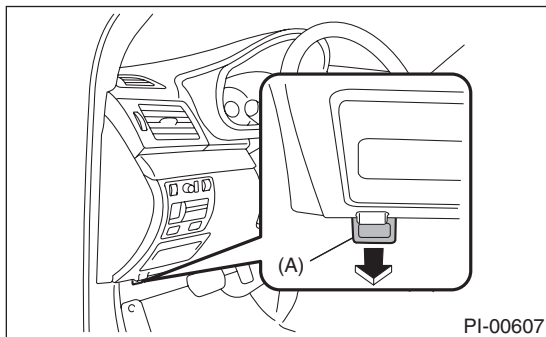

Operate the lever (B) and check that the front hood is opened normally. Check that the front hood can be supported by damper stay.

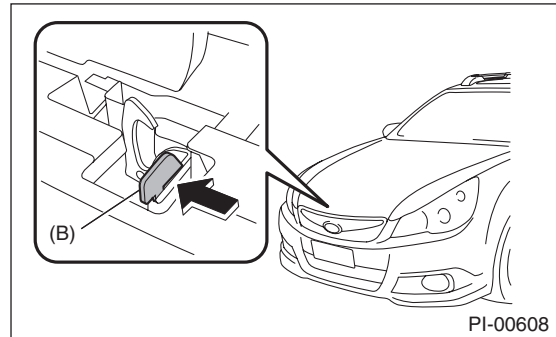

12. BATTERY

Check the battery terminals to make sure that there are no rust or corrosions due to fluid leaks.

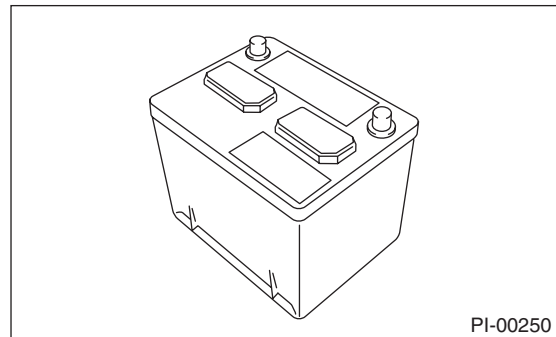

13. BRAKE FLUID

CAUTION:

If the brake fluid is spilt over exhaust pipe, wipe it off with cloth to avoid emitting smoke or causing a fire.

Check that the brake fluid level is normal. If the amount is insufficient, carry out a brake line test to identify brake fluid leaks and check the brake operation. After that, refill the brake fluid tank with the specified type of fluid.

14.ENGINE OIL

CAUTION:

If engine oil is spilt onto the exhaust pipe, wipe it off with cloth to avoid emission of smoke or causing a fire.

Check the engine oil amount. If the amount of oil is insufficient, check that no leaks are found. Then, add the necessary amount of the specified engine oil.

- 2.5 L model

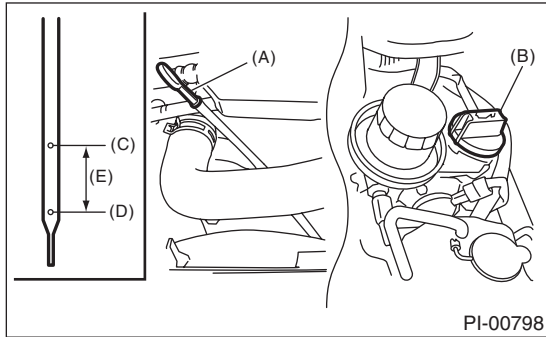

- (A) Oil level gauge
- (B) Engine oil filler cap
- (C) "F" line
- (D) "L" line
- (E) Approx. 1.0 L (1.1 US qt, 0.9 Imp qt)

- 3.6 L model

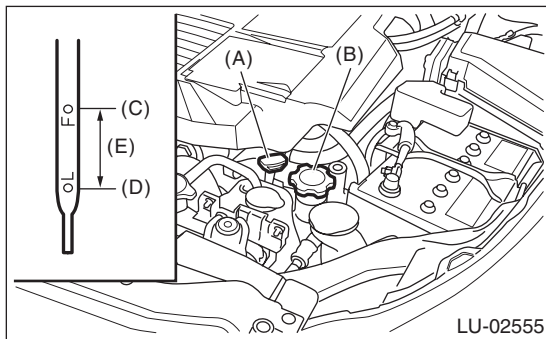

- (A) Oil level gauge
- (B) Engine oil filler cap
- (C) "F" line
- (D) "L" line
- (E) Approx. 1.0 L (1.1 US qt, 0.9 Imp qt)

15.TRANSMISSION GEAR OIL

CAUTION:

If transmission gear oil is spilt over the exhaust pipe, wipe it off with a cloth to avoid emitting smoke or causing a fire.

Check that the transmission gear oil level is normal. If the amount of gear oil is insufficient, check that no leaks are found. Then add the necessary amount of the specified transmission gear oil.

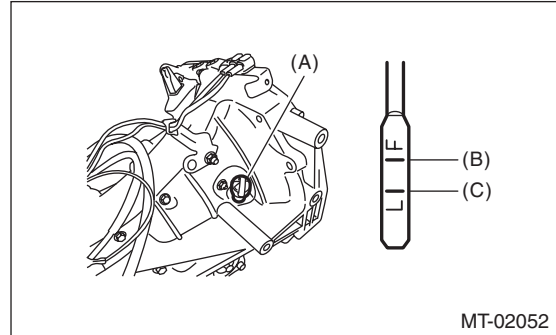

- (A) Oil level gauge
- (B) Upper level
- (C) Lower level

16.AT FRONT DIFFERENTIAL GEAR OIL

CAUTION:

If the differential gear oil is spilt over exhaust pipe, wipe it off with cloth to avoid emitting smoke or causing a fire.

Check that the AT front differential gear oil level is normal. If the amount of oil is insufficient, check that no leaks are found. Then, add the necessary amount of the specified AT front differential gear oil.

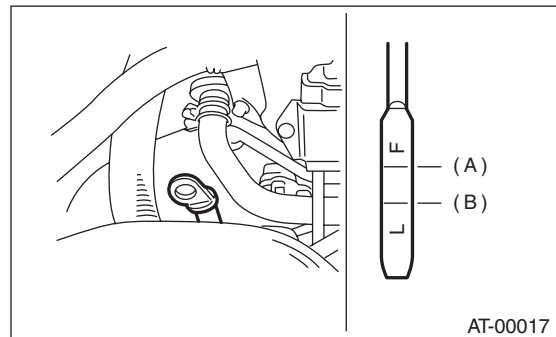

- (A) Upper level
- (B) Lower level

Pre-delivery Inspection

PRE-DELIVERY INSPECTION

17. CVT FRONT DIFFERENTIAL GEAR OIL

CAUTION:

If the front differential gear oil is spilt over exhaust pipe, wipe it off with cloth to avoid emitting smoke or causing a fire.

Check for no leakage of CVT front differential gear oil.

18. REAR DIFFERENTIAL GEAR OIL

CAUTION:

If the rear differential gear oil is spilt over exhaust pipe, wipe it off with cloth to avoid emitting smoke or causing a fire.

Check for leakage of gear oil from the rear differential.

19. ENGINE COOLANT

CAUTION:

If the engine coolant is spilt over exhaust pipe, wipe it off with cloth to avoid emitting smoke or causing a fire.

Check that the engine coolant level on the reservoir tank is normal. If the amount of engine coolant is insufficient, check that no leaks are found. Then, add the necessary amount of coolant with the specified concentration.

20. CLUTCH FLUID

CAUTION:

If the clutch fluid is spilt over the exhaust pipe, wipe it off with cloth to avoid emitting smoke or causing a fire.

Check that the clutch fluid level is normal. If the amount of the fluid is insufficient, check that no leaks are found. Then, add the necessary amount of the specified fluid.

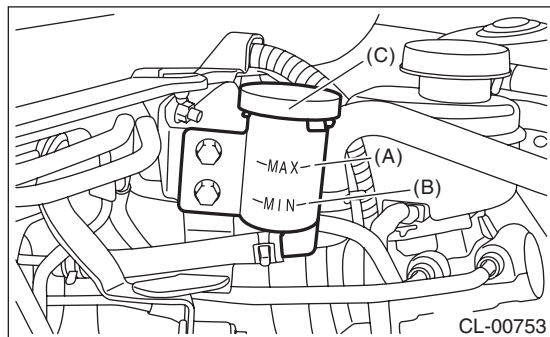

- (A) MAX. level
- (B) MIN. level
- (C) Reservoir tank

21. WINDOW WASHER FLUID

Check that the window washer fluid level is normal. If the amount is insufficient, check that no leaks are found. Then, add the necessary amount of washer fluid.

22. FRONT HOOD LATCH

Close the front hood. Check that the front hood is securely latched.

23. KEYLESS ENTRY SYSTEM

NOTE:

The following inspections show the initial settings. When the settings are different from the initial settings, use Subaru Select Monitor to check the details of each setting for inspections. <Ref. to BC(diag)-16, OPERATION, User Customizing.>

- 1) Fully open all the door windows.
- 2) Remove the key from the ignition switch and close all the doors including rear gate.
- 3) Press the rear gate and trunk open button for at least one second.
 - Check if the trunk is opened and the hazard light blinks twice and the buzzer sounds twice. (Sedan model)
 - Check if the rear gate is unlocked and the hazard light blinks twice and the buzzer sounds twice. (OUTBACK model)

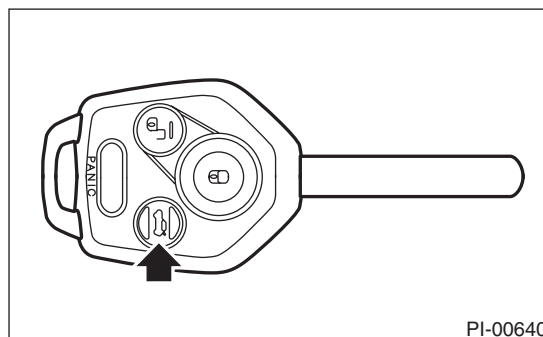

- 4) Press the "LOCK" button on the keyless transmitter with one of the doors (including the rear gate and trunk) opened. Check if all doors are locked, hazard light blinks five times and the buzzer sounds five times and warning shows one of the doors (including the rear gate and trunk) open.

5) Close all the doors including rear gate and trunk. Press the “LOCK” button momentarily on the keyless transmitter. Check that all the doors (including rear gate and trunk) are locked, hazard light blinks once and buzzer sounds once.

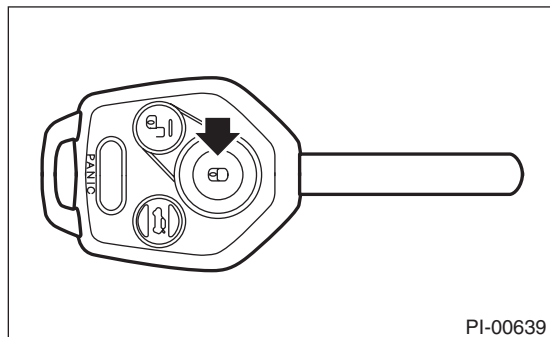

6) Press the “UNLOCK” button momentarily on the keyless transmitter. Check that the driver’s door is unlocked and hazard light blinks twice and the buzzer sounds twice.

And press the “UNLOCK” button momentarily again in 5 seconds. Check that all doors (including rear gate) are unlocked.

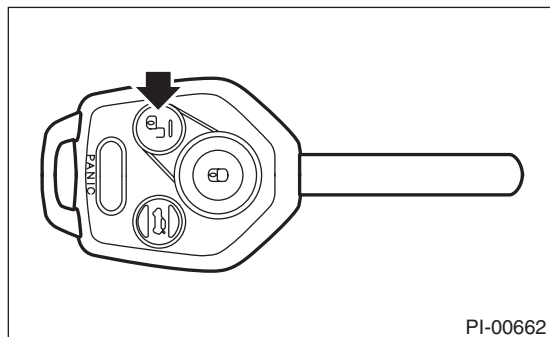

7) Within a distance of 10 m from a vehicle, press keyless transmitter’s “LOCK” button three times within five seconds. Check that the horn honks once and that the hazard light blinks three times.

8) Move the power door lock switch to the lock position with one of doors (including the rear gate) opened. Next, close all the doors including rear gate. Check if all doors are locked and buzzer sounds once and the hazard light flashes once.

9) Check buzzer operation.

The buzzer sounds when the doors are locked or unlocked. The buzzer can be turned off if desired. Turn the buzzer off or on with following procedure.

- (1) Close all the doors including rear gate, then remove the key from ignition key lock.
- (2) Press the power door lock switch to unlock and hold it until the operation is finished.
- (3) Insert the key into ignition key lock, and insert and remove the key in ignition key lock 5 times in 10 seconds.

(4) When finished step (3), open and close the driver’s door once within 10 seconds.

NOTE:

When opening and closing of the door is not available within 10 seconds, hazard light blinks once and the change over operation is cancelled. Retry from the step (1).

(5) Hazard light blinks 3 times and the buzzer sound turns ON or OFF.

10) Press the “PANIC” button of the keyless transmitter. Check if the alarm condition happens (horn sounds continuously, hazard light blinks, security indicator comes on). Check whether this condition lasts until any button on the keyless transmitter is pressed or lasts for 30 seconds.

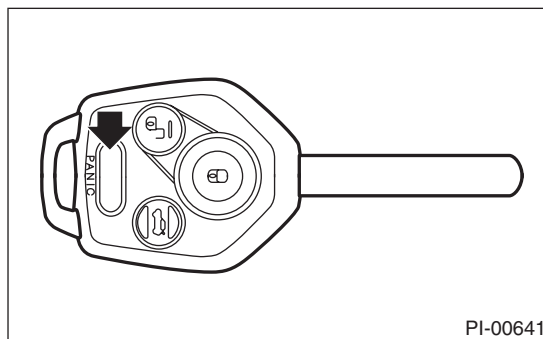

24. KEYLESS ACCESS FUNCTION

CAUTION:

- When performing the check, check one access key at a time, separating individual keys.
- Do not leave any separated access keys in the vehicle.

NOTE:

The following inspections show the initial settings. When the settings are different from the initial settings, use Subaru Select Monitor to check the details of each setting for inspections. <Ref. to BC(diag)-12, OPERATION, Read Current Data.>

- While carrying the access key, check that the room light illuminates when you move close to the front door handles of the vehicle whose doors are all locked.
- While carrying the access key, check that the driver’s door is unlocked and the hazard lights flash by grasping the front door knob on the driver’s side (touching the touch sensor).
- While carrying the access key, check that all doors and the rear gate are unlocked and the hazard lights flash by grasping the front door knob on the passenger’s side (touching the touch sensor).

Pre-delivery Inspection

PRE-DELIVERY INSPECTION

- While carrying the access key, check that all doors and the rear gate are locked and the hazard lights blink when you press the front lock button on the door or the rear lock button on the rear gate.

NOTE:

- The hazard lights flash twice when unlocking.
- The hazard lights flash once when locking.

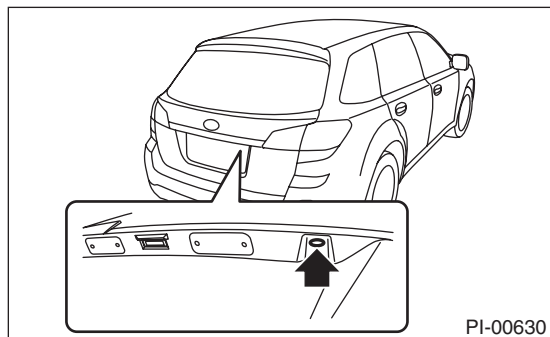
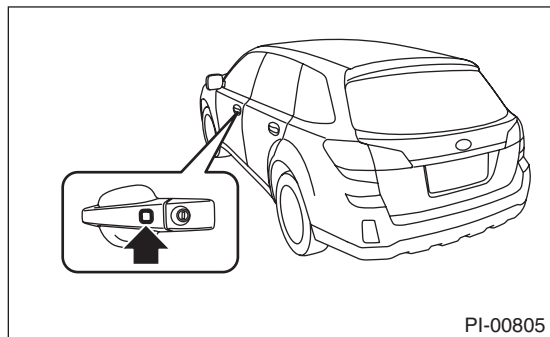

- While carrying the access key, check that the rear gate unlocks and the hazard lights flash twice when you press the rear gate opener button of the rear gate.

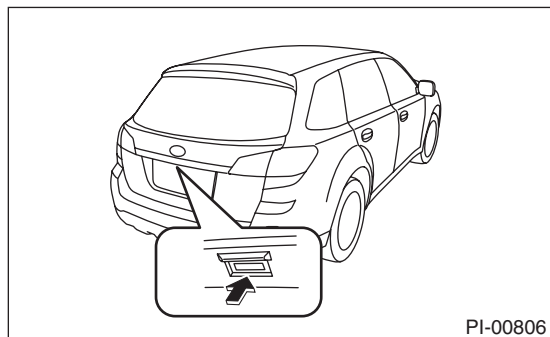

- Manually operate the access key button to check the lock/unlock of doors and rear gate, and the flashing of hazard lights.

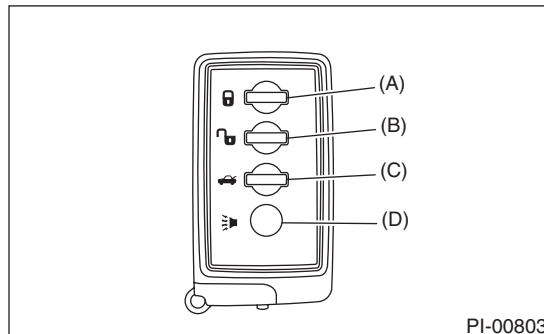

- (A) LOCK button
- (B) UNLOCK button
- (C) Rear gate unlock button
- (D) Panic button

- Check the mechanical key attached to the access key can be used for locking/unlocking.

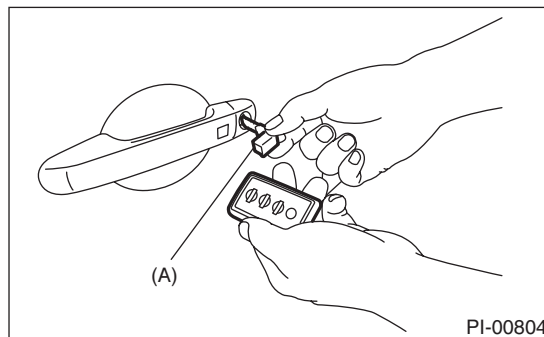

- (A) Mechanical key

- With the access key in the vehicle, check that warning buzzer sounds and locking does not occur when you press the front lock button or rear lock button.

CAUTION:

Remove the mechanical key from the access key and hold the mechanical key.

25.SECURITY SYSTEM (ALARM SYSTEM)

NOTE:

The following inspections show the initial settings. When the settings are different from the initial settings, use Subaru Select Monitor to check the details of each setting for inspections. <Ref. to BC(diag)-16, OPERATION, User Customizing.>

- 1) Fully open all the door windows.
- 2) Remove the key from the ignition switch and close all the doors including rear gate.

3) Press the “LOCK” button momentarily on the keyless transmitter. All doors are locked, and the security indicator light blinks faster (five times per two seconds) for 30 seconds and goes slower (twice per two seconds), then the alarm system is in set condition.

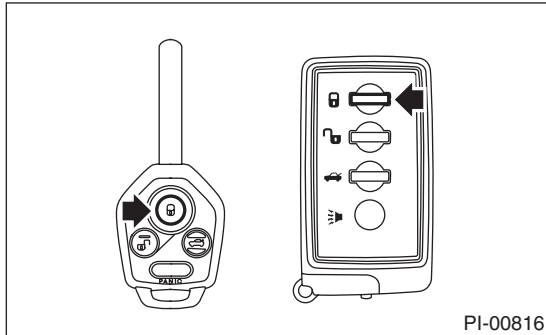

4) Press the “UNLOCK” button momentarily on the keyless transmitter. When the door of the driver’s seat is unlocked, the security indicator light operates (flashes once in three seconds), and the alarm system enters the release mode.

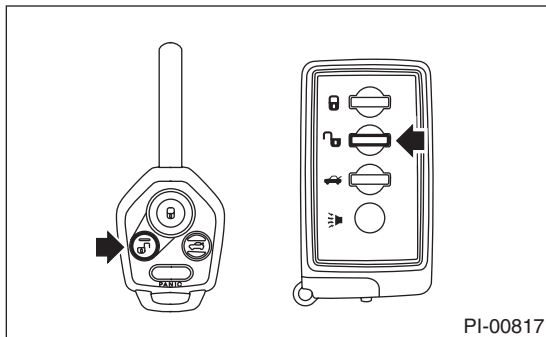

5) Close all the doors including rear gate. Press the “LOCK” button momentarily on the keyless transmitter. All doors are locked and the alarm system is in set condition after 30 seconds.

6) Unlock the door using the inner lock knob and open the door while the alarm system is in the set mode. Check if the alarm condition happens (horn sounds continuously, hazard light blinks, security indicator illuminates). Check if this condition lasts for a maximum of three minutes or until the “UNLOCK” button of the keyless transmitter is pressed.

NOTE:

The alarm condition will cease in 30 seconds once the door is closed.

7) When none of above is applicable, perform troubleshooting for the security system.

26. SEAT

- 1) Check the seat surfaces for stains or dirt.
- 2) Check that each seat provides full functionality in sliding, reclining, lifter, and tilting. Check that the seat position memory for driver’s power seat function properly. Check all available functions of the rear seat such as a trunk-through and center armrest.
- 3) Check the passenger’s seat occupant detection system.

- (1) Turn the ignition switch to ON.
- (2) Check the ON and OFF of passenger’s air-bag indicator light come on simultaneously for about 6 seconds and go off for 2 seconds, and then only OFF illuminates again.

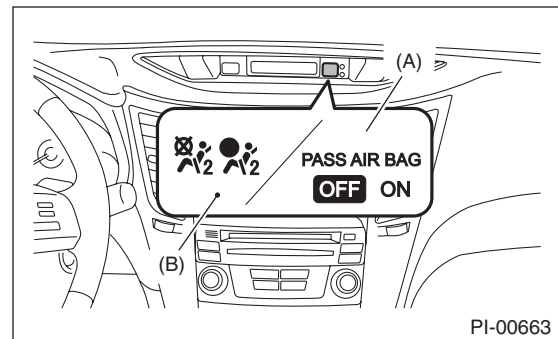

- (A) Indication for US
 (B) Indication for Canada

- (3) Have a person weighing approximately 70 kg (155 lb) or more sit in the passenger’s seat, and check whether the passenger’s airbag indicator light illuminate or not.

- (4) Empty the passenger seat, then check whether the passenger side airbag indicator light OFF illuminates.

27. SEAT BELT

- 1) Check installation condition of seat belt.
- 2) Pull out the seat belt and then release it. Check that the belt retracts smoothly.
- 3) Check that the ALR seat belt operates normally.
- 4) Check seat belt warning function.

- (1) Turn the ignition switch to ON with the driver’s and passenger’s seat belt detached.
- (2) Check the driver’s and passenger’s seat belt warning light blink for approx. 6 seconds and the buzzer sounds intermittently.
- (3) Then, check the seat belt warning light illuminates and blinks repeatedly at a cycle of approx. 15 seconds. (If no passenger is on the passenger’s seat, the seat belt warning light on passenger’s seat does not operate.)

Pre-delivery Inspection

PRE-DELIVERY INSPECTION

(4) When the driver's seat belt is fastened, check that the driver's seat belt warning light turns off.

(5) When the passenger's seat belt is fastened, check that the passenger's seat belt warning light turns off. (If no passenger is on the passenger's seat, the seat belt warning light on passenger's seat does not operate.)

28.TPMS

1) Turn the ignition switch to ON, and check TPMS warning light for normal operation.

- Normal operation (IG ON (light check))

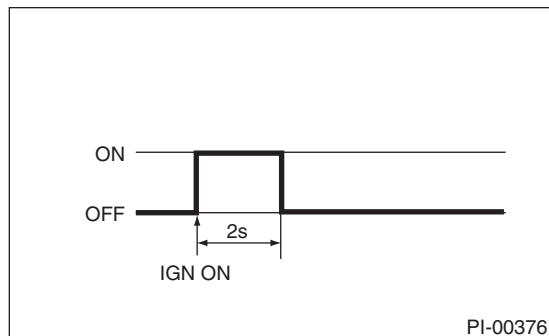

2) If the TPMS warning light display does not operate normally, check and repair the system. <Ref. to TPM(diag)-2, Basic Diagnostic Procedure.>

29.IMMOBILIZER SYSTEM

1) Check that the engine starts with all keys that are equipped on vehicle.

2) 60 seconds after turning ignition switch from ON to ACC or OFF, or immediately after removing the key, check that the security indicator light is blinking. (model without keyless access function)

3) Immediately after turning ignition switch from ON to ACC or OFF, or when opening/closing a door while the ignition switch is in ON or ACC, check that the security indicator light is blinking. (model with keyless access function)

4) For the model for Canada, execute Each System Check > Integ. unit mode > "SCU Collation Mode" on SSMIII to check [Collation OK (no error)] is displayed.

NOTE:

If malfunctions occur, refer to "IMMOBILIZER (DIAGNOSTICS)".

30.STARTING CONDITION

Start the engine and check that the engine starts smoothly. If the battery voltage is low, recharge or replace the battery. If any noises are observed, immediately stop the engine and check and repair the abnormal components.

31.EXHAUST SYSTEM

Listen to the exhaust noise to see if no exhaust gas leak or abnormal noises are observed.

32.INDICATOR LIGHT AND WARNING LIGHT

Check that all indicator lights and warning lights operate normally.

33.HEATER & VENTILATION

Operate the heater & ventilation system to check for normal airflow outlet control, air inlet control, airflow capacity and heating performance.

34.AIR CONDITIONER

Operate the air conditioner. Check that the A/C compressor operates normally and enough cooling is provided.

NOTE:

To prevent the insufficient lubrication of the air conditioner, operate the air conditioner for five minutes at idling.

35.CLOCK

Check the clock for normal operations and enough accuracy. Check the fuel economy display switches by operating the knob on the meter. Also check there is no significant error on the outside temperature display.

36.AUDIO

Check that all radio functions operate, the speakers emit sound properly and the noise is at an acceptable level. Also check the CD unit and AUX unit operations.

37.NAVIGATION SYSTEM

1) Check all display functions for normal operation. (Refer to the owner's manual for the operation procedures.)

2) Check that the navigation system operates normally.

3) Check that the rearview camera operates normally.

38.ACCESSORY POWER SUPPLY SOCKET

1) Check the operation of the front accessory power supply socket.

2) Check operation of the accessory power supply socket in console box.

39.LIGHTING SYSTEM

1) Check the headlight operation.

2) Check the stop light operation.

3) Check other lights for normal operations.

40. WIPER DEICER

Check that the wiper deicer operates normally.

NOTE:

When an ambient temperature is 5°C or more, wiper deicer operation is cancelled. Press the switch for 3 seconds or more to perform the compulsory operation.

41. ILLUMINATION CONTROL

Check that the illumination control operates normally.

42. WINDOW WASHER

Check that the window washer system injects washer fluid to the specified area of the windshield and rear window glass shown in the figure.

Front injection position:

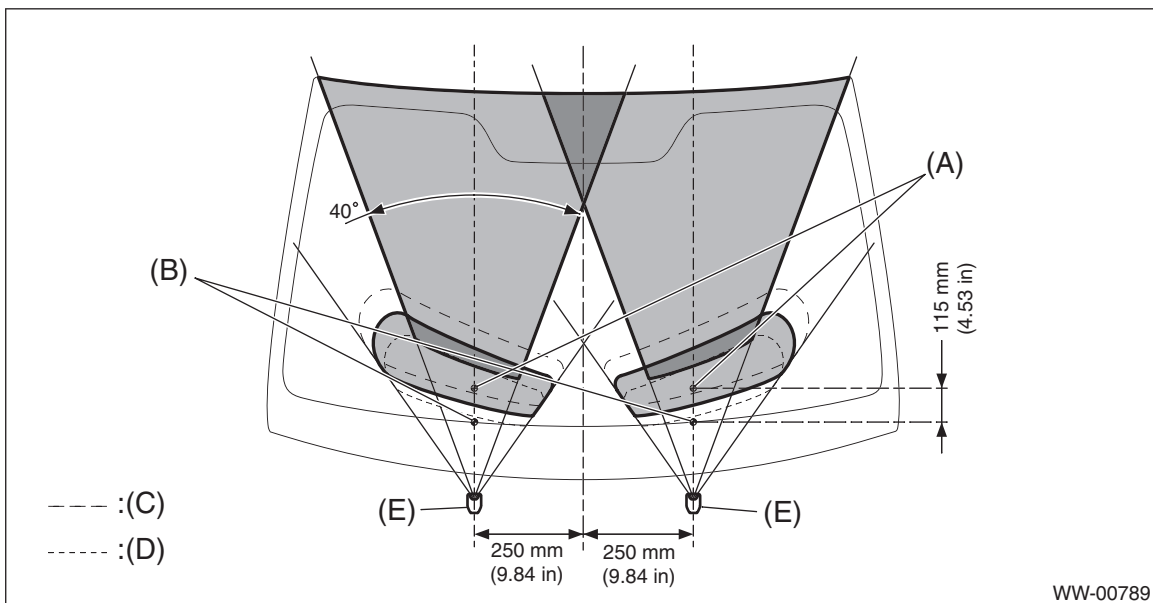

- (A) Lower-side spray position center
- (B) Ceramic line position on the washer nozzle center
- (C) Washer nozzle elevation angle, upper limit of spray area
- (D) Washer nozzle elevation angle, lower limit of spray area
- (E) Washer nozzle

Rear injection position:

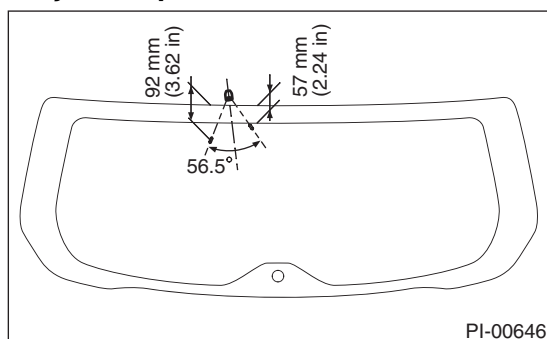

Pre-delivery Inspection

PRE-DELIVERY INSPECTION

43. WIPER

Check the front and rear wipers for normal operations.

44. POWER WINDOW

- Operate the power window switches one by one to check that each of the power windows goes up and down without noises.
- Check AUTO UP/AUTO DOWN operate properly by operating the power window switch on driver's seat side.

CAUTION:

If battery has been removed, AUTO UP does not operate properly because initialized. In this case, perform the initial setting (reset A) and check AUTO UP operates properly.

45. SUNROOF

Check that the sunroof operates normally.

46. DOOR MIRROR

Check that the remote control mirror and heated mirror operate normally.

47. ROOM MIRROR (EC AND RCD MODELS)

- 1) Check all display functions for normal operation. (RCD model)
- 2) Check that the automatic anti-glare function operates normally. (EC and RCD models)
- 3) Check that the rearview camera operates normally. (RCD model)

48. REAR DEFOGGER

Check that the rear defogger system operates normally.

49. PARKING BRAKE

Check the parking brake operates properly by depressing brake pedal and pressing the electronic parking brake switch.

50. BRAKE TEST

Check the foot brake for normal operations.

51. AT, CVT SHIFT CONTROL

- 1) Turn the ignition switch to ON.
- 2) While brake pedal is not depressed, check if the select lever does not move from "P" range.
- 3) While brake pedal is depressed, check if the select lever moves from "P" range.
- 4) Set the select lever to other than "P" range.
- 5) When the ignition switch is turned to OFF, check if the ignition key switch cannot be removed.
- 6) Set the selector lever to "D" range and check the shifting while driving the vehicle.

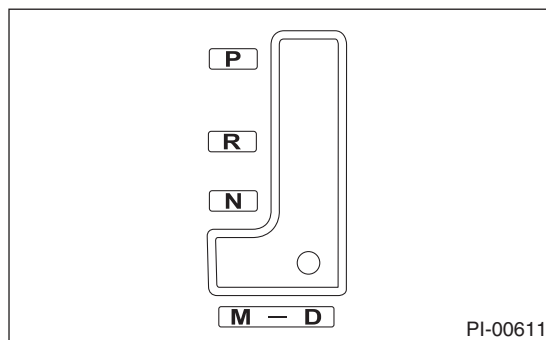

52. MT SHIFT CONTROL

- 1) Check for smooth operation to each position. Especially, shifting to 5th \leftrightarrow 6th, and then to Rev, check for any drag.
- 2) Check the slider returns to the original position by shifting to the Rev and then back in neutral while pulling up the slider.
- 3) If the shifting operation is not smooth, readjustment the exposed length (a) of MT gear select cable following the figure.

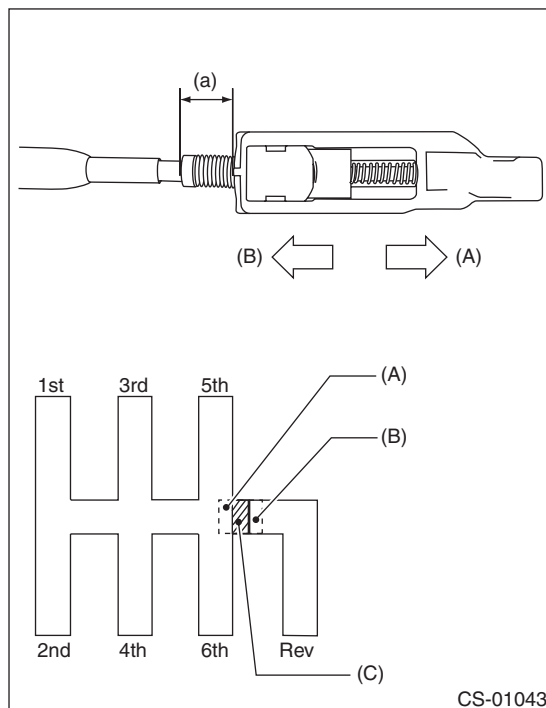

- (a) Exposed length of MT gear select cable
- (A) Extend direction of exposed length of MT gear select cable
- (B) Shorten direction of exposed length of MT gear select cable
- (C) Specification of exposed length (a)

- If the shift cannot be inserted to push the reverse lock bracket 5th and 6th.
→ Extend the exposed length (a) of MT gear select cable.

- When operate the select lever to 4th → 5th, it cannot be operated at select lever crank line.
→ Shorten the exposed length (a) of MT gear select cable.

53. CRUISE CONTROL

Operate the cruise control system. Check that the system is activated and deactivated correctly.

54. SUBARU EyeSight

- Operate the EyeSight system. Check that the system is activated and deactivated correctly.
- Check the stereo camera cover opening for foreign matter.
- Check the glass in front of stereo camera for dirt and stickers.
- Check the lens portion of stereo camera for dirt such as fingerprints.
- Check the filter at lens portion of stereo camera for damage.
- According to the “ES(diag)” section, check the windshield glass and dashboard in front of stereo camera to make sure that no aftermarket part is adhered or attached in the prohibited area. <Ref. to ES(diag)-8, WINDSHIELD GLASS AND DASHBOARD, INSPECTION, General Description.>
- When delivering the vehicle, explain to the customer to make sure not to touch the lens portion of stereo camera.

55. ATF LEVEL

CAUTION:

If the ATF is spilt over exhaust pipe, wipe it off with cloth to avoid emitting smoke or causing a fire.

After selecting all positions (P, R, N, D), set the select lever in “P” range. Idle the engine for 1 or 2 minutes, and measure the ATF level. If the amount is insufficient, check that no leaks are found. Then, add the necessary amount of the specified ATF.

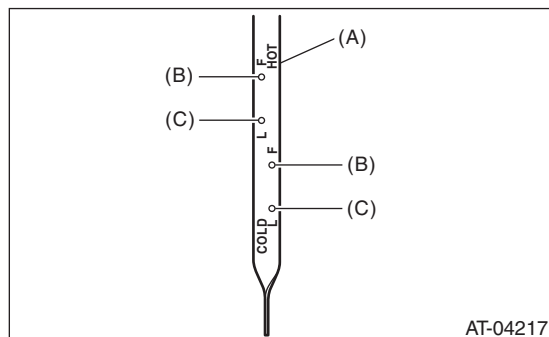

- (A) Level gauge
- (B) Upper level
- (C) Lower level

56. POWER STEERING FLUID LEVEL

CAUTION:

If any power steering fluid is spilt over the exhaust pipe, wipe it off with a cloth to avoid emitting smoke or causing a fire.

Check that the power steering fluid level is normal. If the amount is insufficient, check that no leaks are found. Then add the necessary amount of the specified power steering fluid.

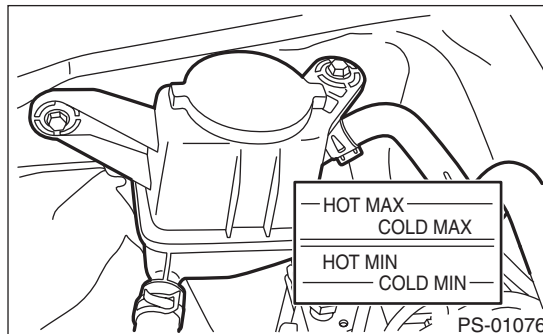

57. OIL LEAKAGE

Check entire areas of the vehicle for any trace of coolant/oil (such as engine and gear oil)/fluid (such as transmission and brake) leaks.

58. WATER LEAK TEST

Spray the vehicle with water using a hose and check that no water enters the passenger compartment.

- Before performing the water leakage test, remove anything that may obstruct the operation or which must be kept dry.
- Close all the windows and doors securely. Close the front hood and trunk lid before starting the test.
- Spray the vehicle with water using a hose. The rate of water spray must be approx. 20 to 25 L (5.3 — 6.6 US gal, 4.4 — 5.5 Imp gal) per minute.

When spraying water on areas adjacent to the floor and wheel house, increase the pressure. When spraying water on areas other than the floor and wheel house, decrease the pressure. But the force of water must be made strong occasionally by pressing the end of the hose.

NOTE:

Be sure to keep the hose at least 10 cm (3.9 in) away from vehicle.

Check the following areas.

- Front window and body framework mating portion
- Door mating portions
- Glass mating portions
- Rear quarter window mating portions
- Rear window and body framework mating portion
- Around roof drips

Pre-delivery Inspection

PRE-DELIVERY INSPECTION

If any dampness in the compartments is discovered after the water has been applied, carefully check all the areas that may have possibly contributed to the leak.

59. APPEARANCE CHECK 2

1) If protective coating (lap guard) is applied, remove it.

NOTE:

- It is easier to remove the wrap guard using steam.
- For a vehicle left for a long time or at low temperature, sprinkle some water heated to 50 — 60°C (122 — 140°F) over the vehicle to raise its surface temperature before peeling off the wrap guard. Do not use the water heated to over 60°C (140°F).
- If the adhesive remains exist on the coated surface, soak a flannel rag, etc. with a small amount of coating wax or solvent such as oil benzene and IPA, put the soaked cloth on the remains lightly, and then wipe them off with a flannel rag etc.
- Keep solvent from touching the resin or rubber parts. Do not use coating wax or solvent while the component surface temperature is high due to hot weather etc.
- If the coated surface is swollen out due to seams or moisture, expose the vehicle to the sunlight for a few hours or heat the seam and swollen portions using a dryer etc.
- Dispose of the peeled wrap guard as burnable industrial garbage.
- If a yellow label is attached to the fog light lens, remove it.

2) Check the whole vehicle body for flaking paint, damage by transportation, corrosion, dirt, cracks or blisters.

NOTE:

- It is better to determine an inspection pattern in order to avoid missing an area, since the total inspection area is wide.
- Do not repair the body paint unless absolutely necessary. Also, if the vehicle is in need of repair to remove scratches or corroded paint, the repair area must be limited to the minimum. Re-painting and spray painting must be avoided as much as possible.

3) Check each window glass for scratches carefully. Slight damage may be removed by polishing with cerium oxide. (Fill a cup half with cerium oxide, and add warm water to it. Then agitate the content until it turns to wax. Apply this wax to a soft cloth, and polish the glass with it.)

4) Check each portion of the vehicle body and underside components for the formation of rust. If rust is discovered, remove it with sandpaper of #80 to #180 and treat the surface with rust preventive. After this treatment is completed, flush the portion thoroughly, and prepare the surface for repair painting.

5) Check each portion of body and all of the exterior parts for deformation or distortion. Also, check each light lens for cracks.

6) Peel the protective tape, vinyl wrapping and identification seal attached to the following places.

- Seat
- Door trim
- Floor carpet
- Side sill
- Front hood lock release lever
- Edge rear
- Rear wiper
- Sedan rear combination light (Trunk lid opening portion)
- Roof rail
- Assist rail
- Door mirror (except for North America)

PERIODIC MAINTENANCE SERVICES

PM

	Page
1. General Description	2
2. Schedule	3
3. Engine Oil	7
4. Engine Oil Filter	8
5. Spark Plug	9
6. V-belt	10
7. Fuel Line	11
8. Fuel Filter	12
9. Air Cleaner Element	13
10. Cooling System	14
11. Engine Coolant	15
12. Clutch System	16
13. Transmission Gear Oil	17
14. Automatic Transmission Fluid	18
15. CVTF	19
16. Front & Rear Differential Gear Oil	20
17. Brake Line	21
18. Brake Fluid	22
19. Disc Brake Pad and Disc	23
20. Parking Brake	24
21. Suspension	25
22. Wheel Bearing	28
23. Axle Boots & Joints	29
24. Tire Inspection and Rotation	30
25. Steering System (Power Steering)	31
26. A/C Filter	33