

Combination Meter System

WIRING SYSTEM

14. Combination Meter System

A: WIRING DIAGRAM

1. MODEL WITH NORMAL METER

C/M(NM)-01

C/M(NM)-01

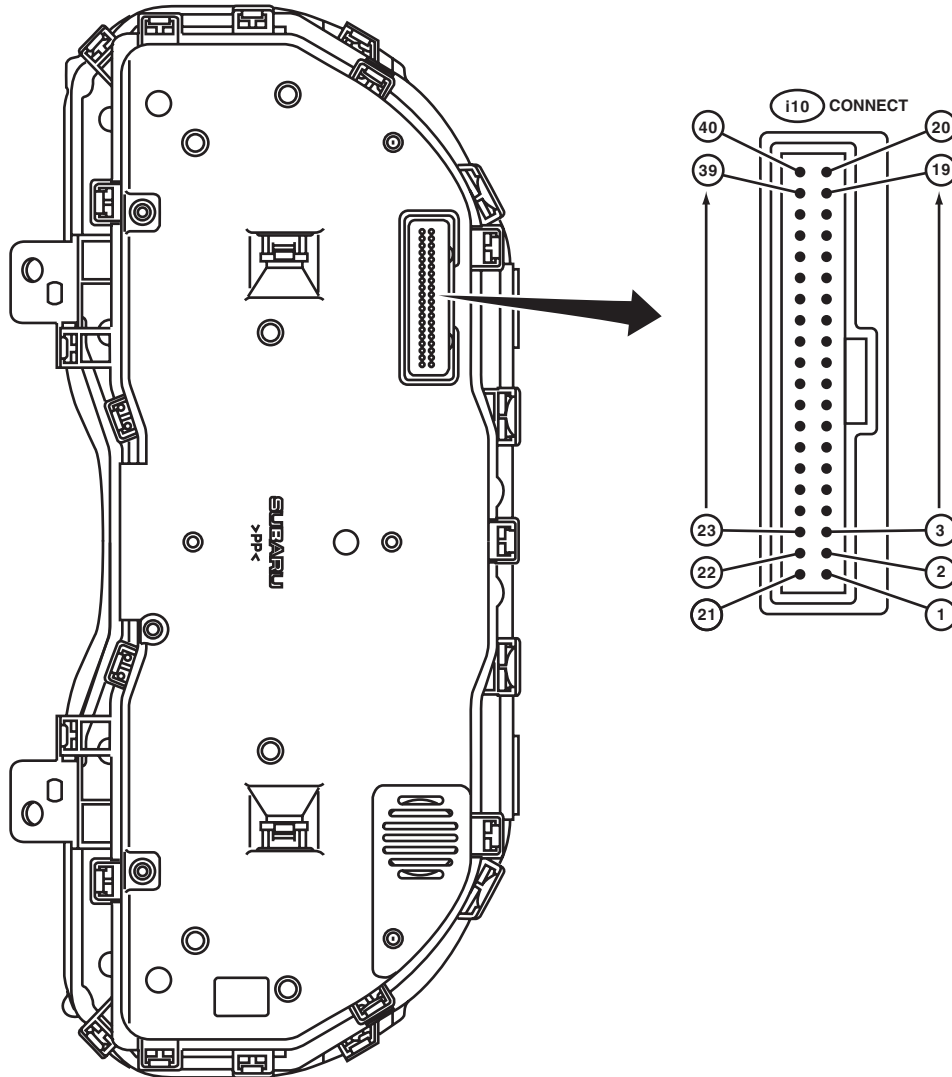

WI-36188

Combination Meter System

WIRING SYSTEM

C/M(NM)-02

C/M(NM)-02

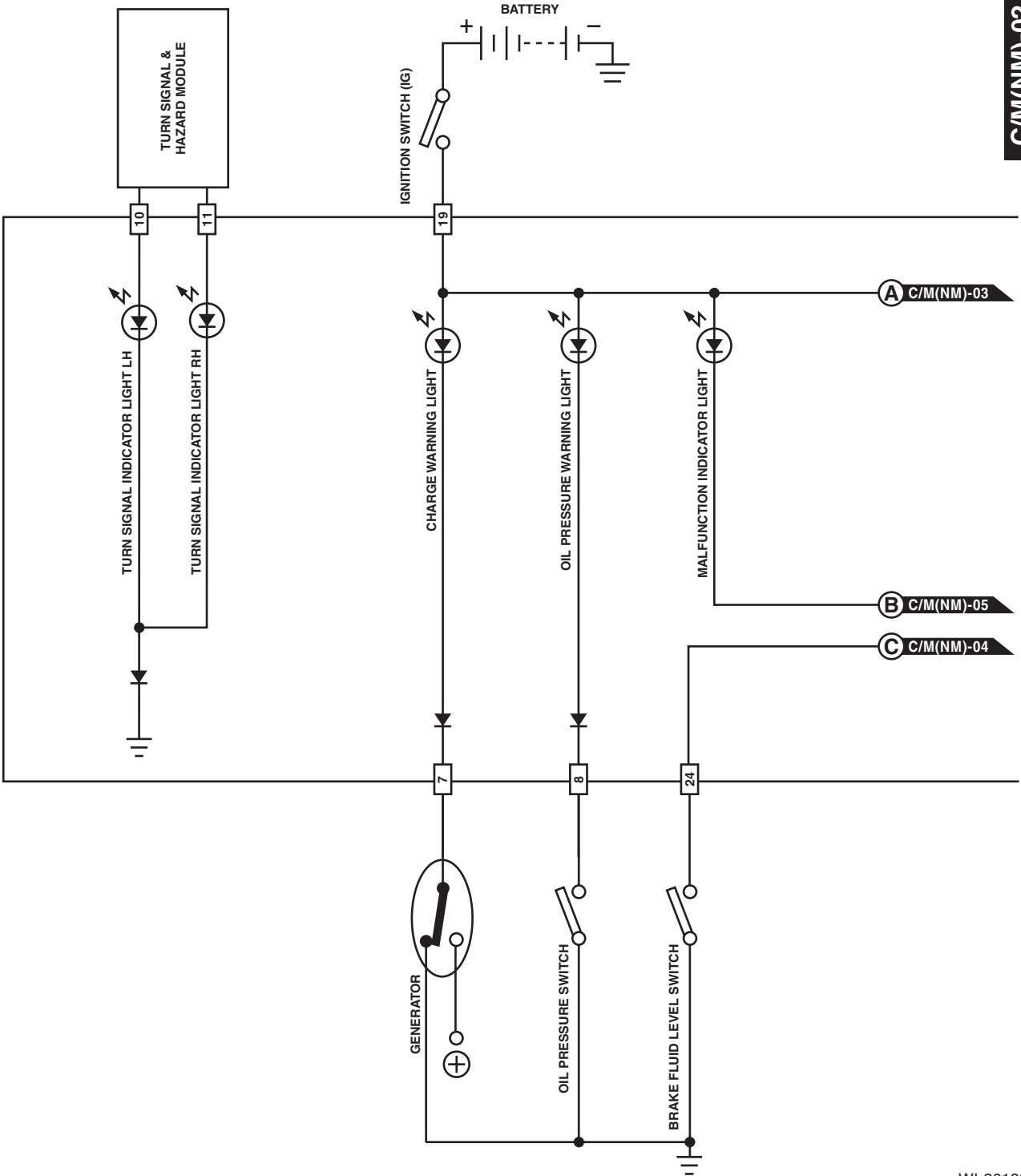

WI-36189

Combination Meter System

WIRING SYSTEM

C/M(NM)-03

C/M(NM)-03

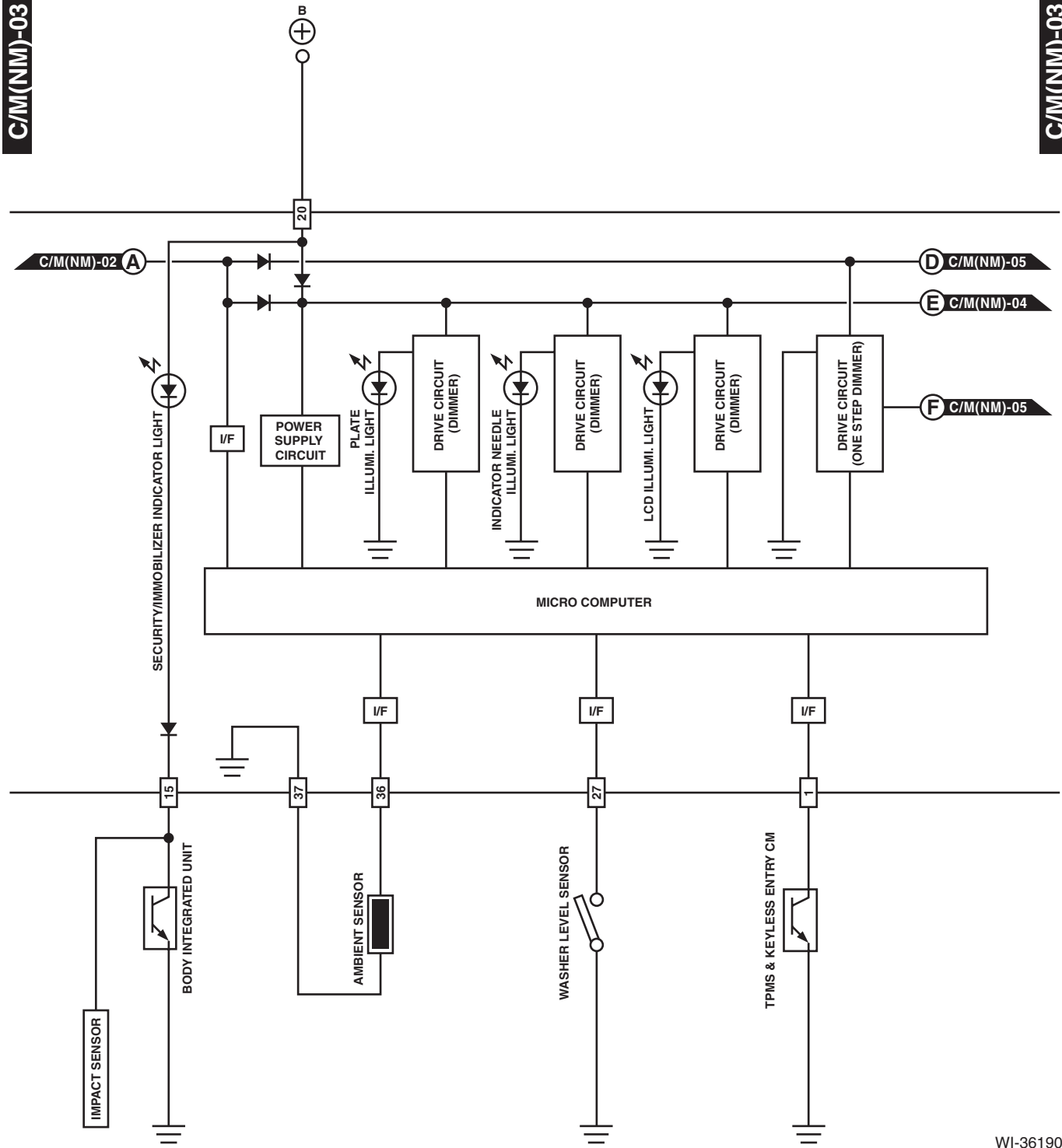

WI-36190

Combination Meter System

WIRING SYSTEM

C/M(NM)-04

C/M(NM)-04

- *1 : MANUAL SHIFT
 HIGH ENGINE OIL TEMPERATURE
 CUSTOMIZED
 SEAT BELT
 KEY WARNING
 HEADLIGHT ON WARNING
- SC : WITH SECURITY CM
 OA : EXCEPT FOR NORMAL AUDIO MODEL
 WN : WITH NAVIGATION
 WS : WITH SUNROOF
 EM : EXCEPT FOR MT MODEL
 WP : WITH PUSH BUTTON START

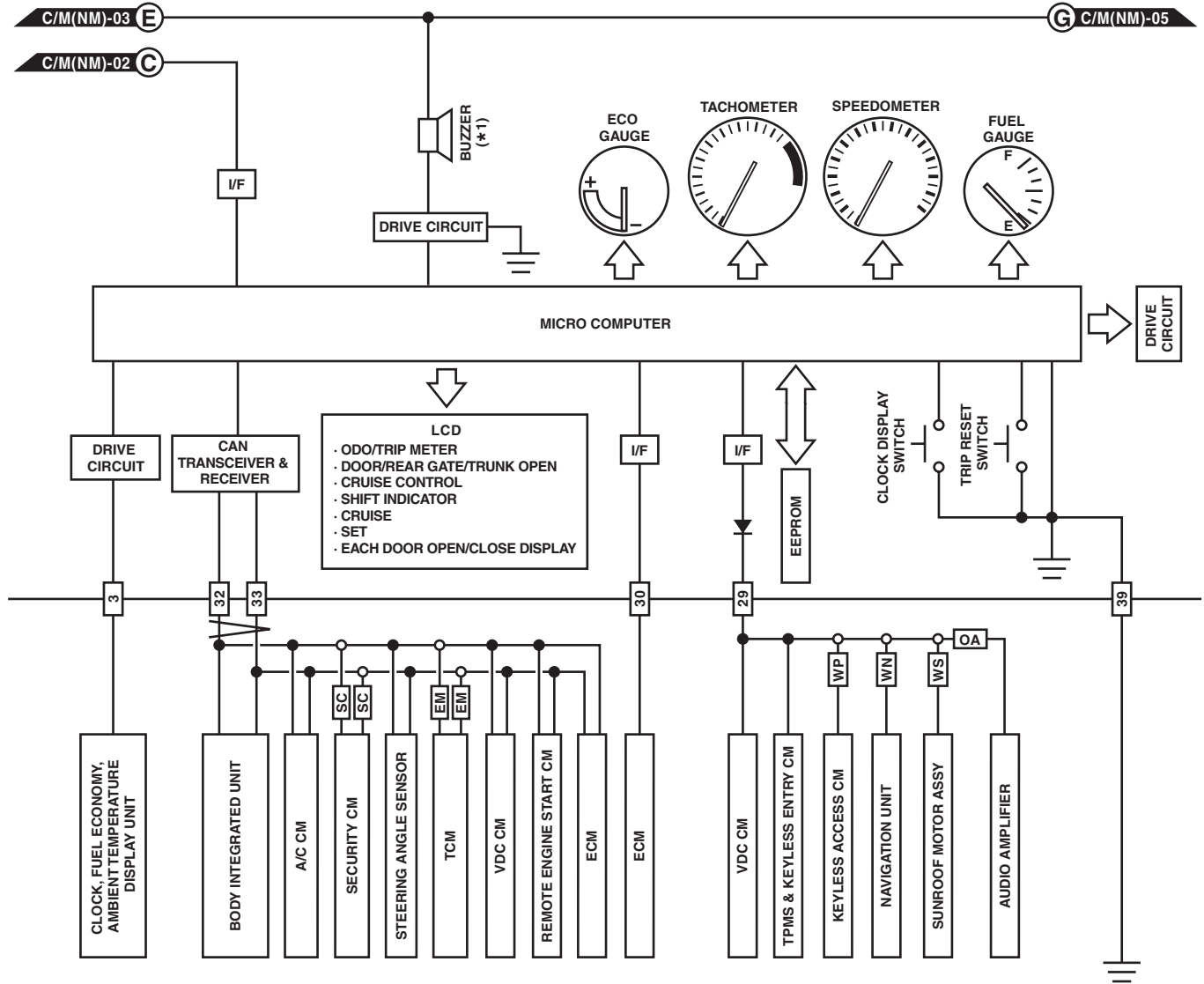

WI-36191

Combination Meter System

WIRING SYSTEM

C/M(NM)-05

C/M(NM)-05

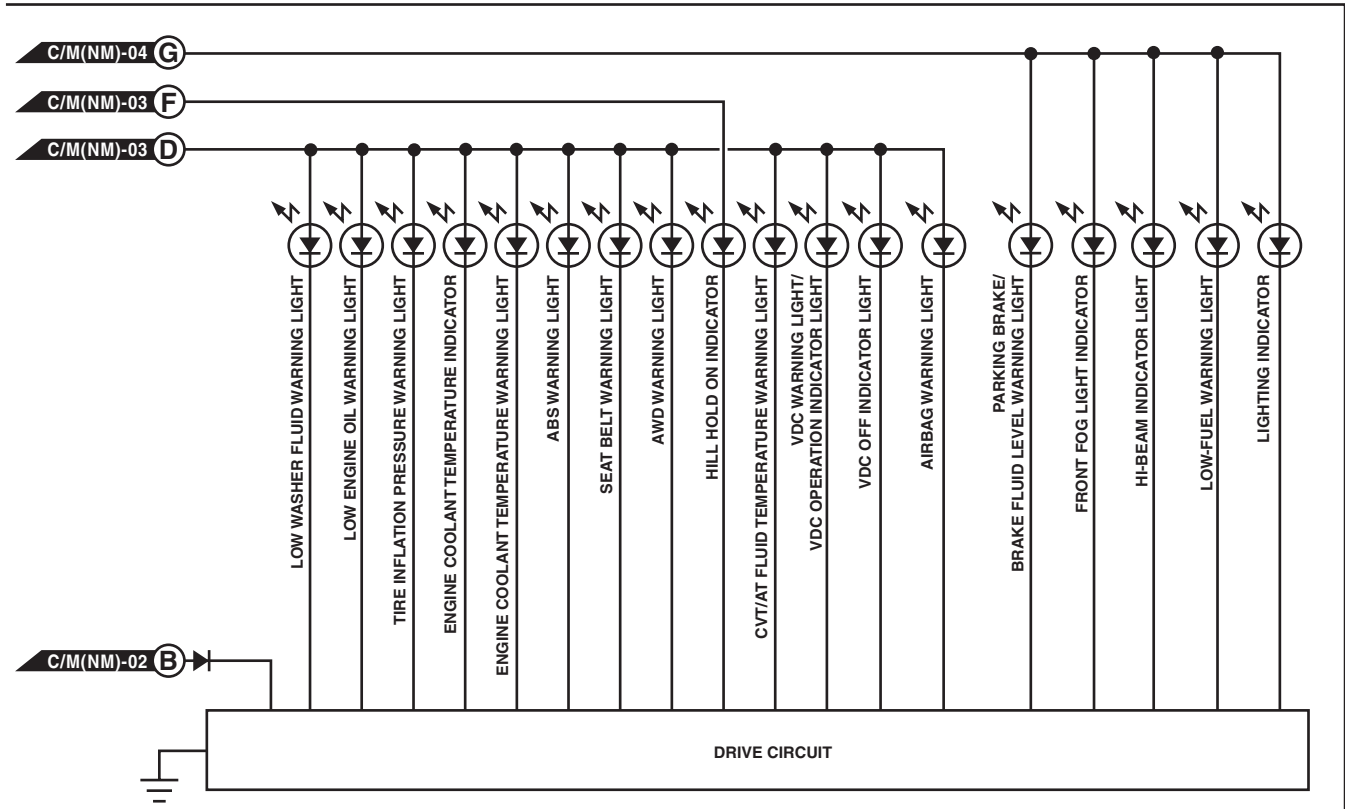

WI-36192

2. MODEL WITH LUMINESCENT METER

C/M(LM)-01

C/M(LM)-01

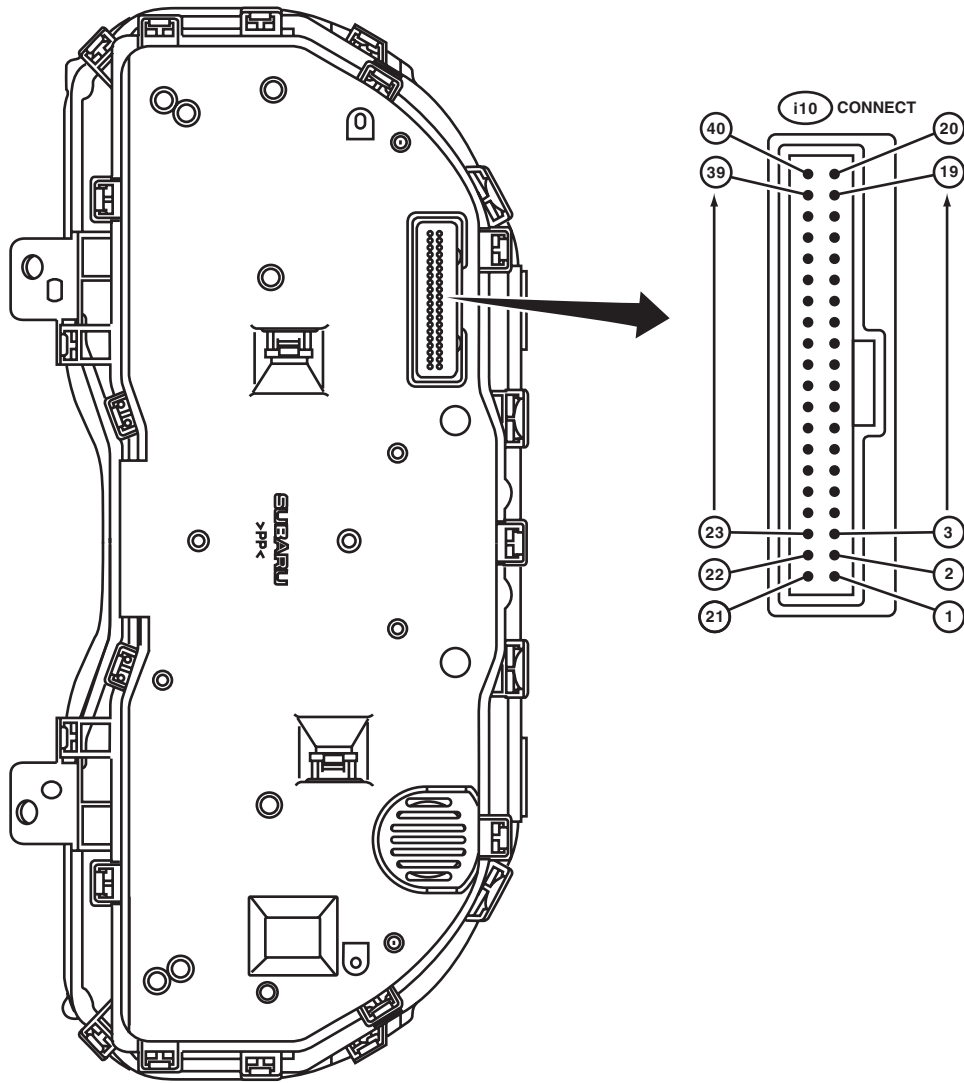

WI-36193

Combination Meter System

WIRING SYSTEM

C/M(LM)-02

C/M(LM)-02

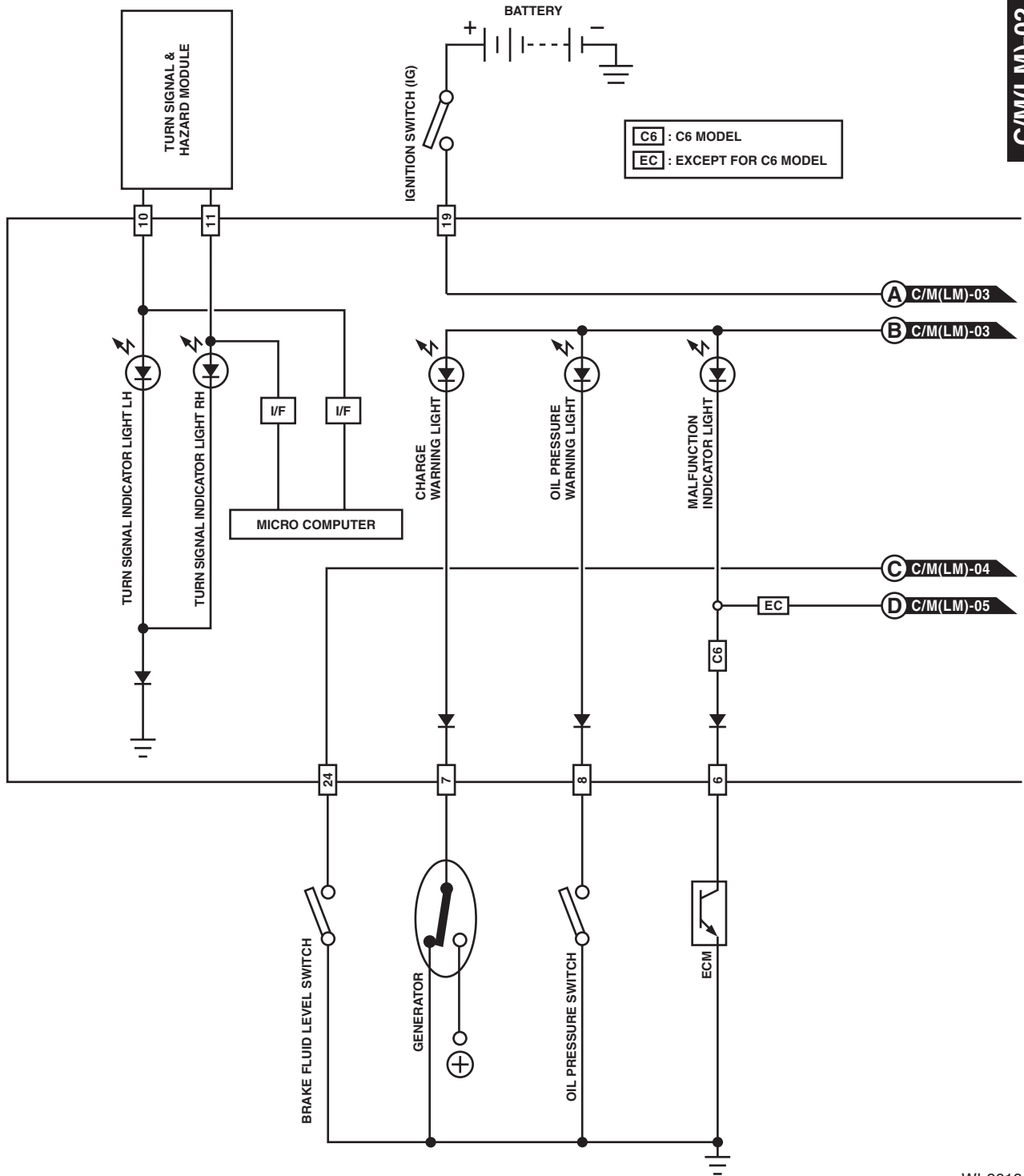

A C/M(LM)-03

B C/M(LM)-03

C C/M(LM)-04

D C/M(LM)-05

WI-36194

Combination Meter System

WIRING SYSTEM

C/M(LM)-03

C/M(LM)-03

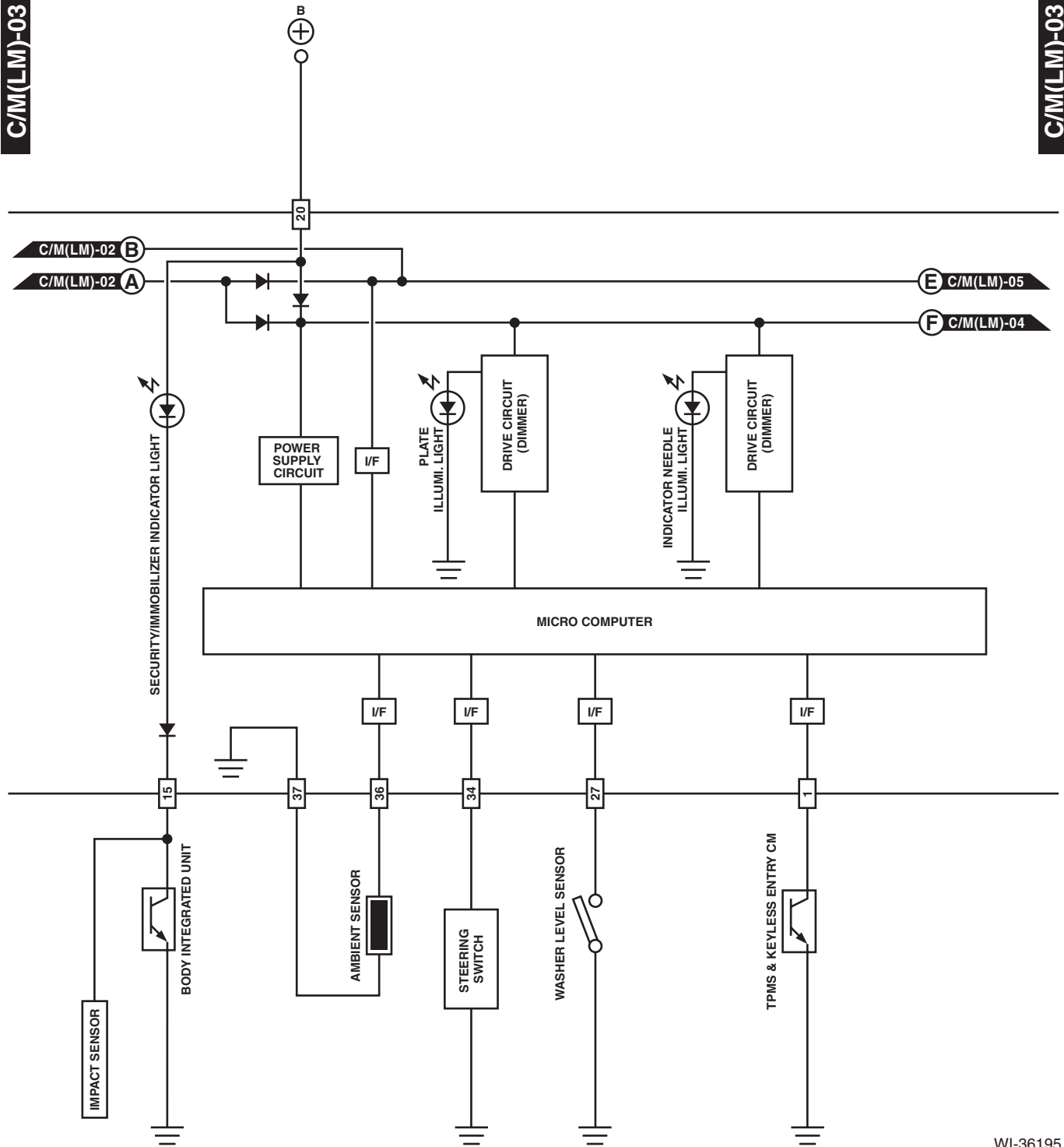

WI-36195

Combination Meter System

WIRING SYSTEM

C/M(LM)-04

C/M(LM)-04

- | | |
|-----------------------------|------------------------------------|
| *1 : MANUAL SHIFT | SC : WITH SECURITY CM |
| HIGH ENGINE OIL TEMPERATURE | OA : EXCEPT FOR NORMAL AUDIO MODEL |
| CUSTOMIZED | WN : WITH NAVIGATION |
| SEAT BELT | WS : WITH SUNROOF |
| EPB | EM : EXCEPT FOR MT MODEL |
| KEY WARNING | WP : WITH PUSH BUTTON START |
| HEADLIGHT ON WARNING | |
| KEYLESS ACCESS | |
| EyeSight | |

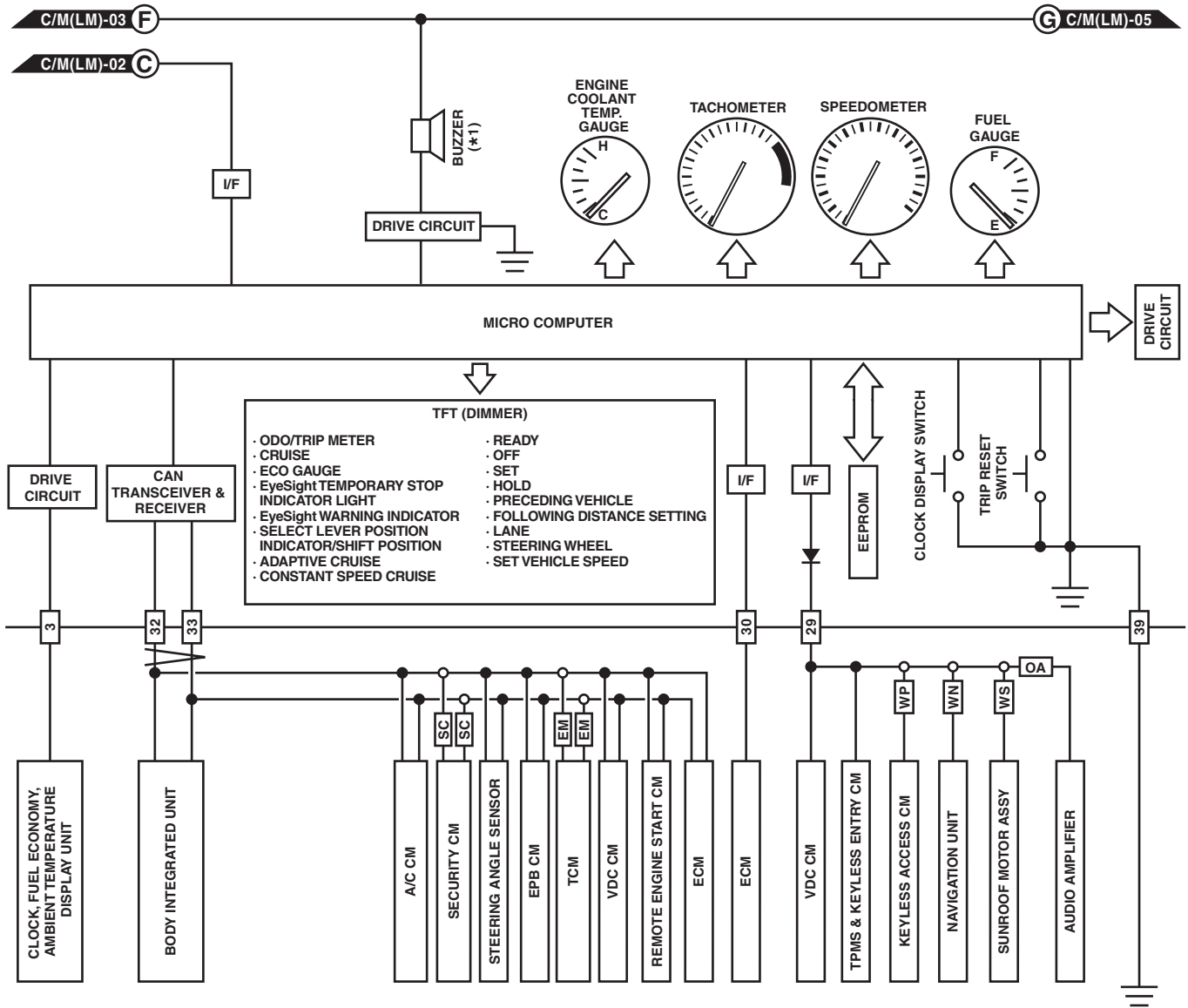

WI-36196

Combination Meter System

WIRING SYSTEM

C/M(LM)-05

C/M(LM)-05

C6	: C6 MODEL
EC	: EXCEPT FOR C6 MODEL
ES	: WITH EyeSight

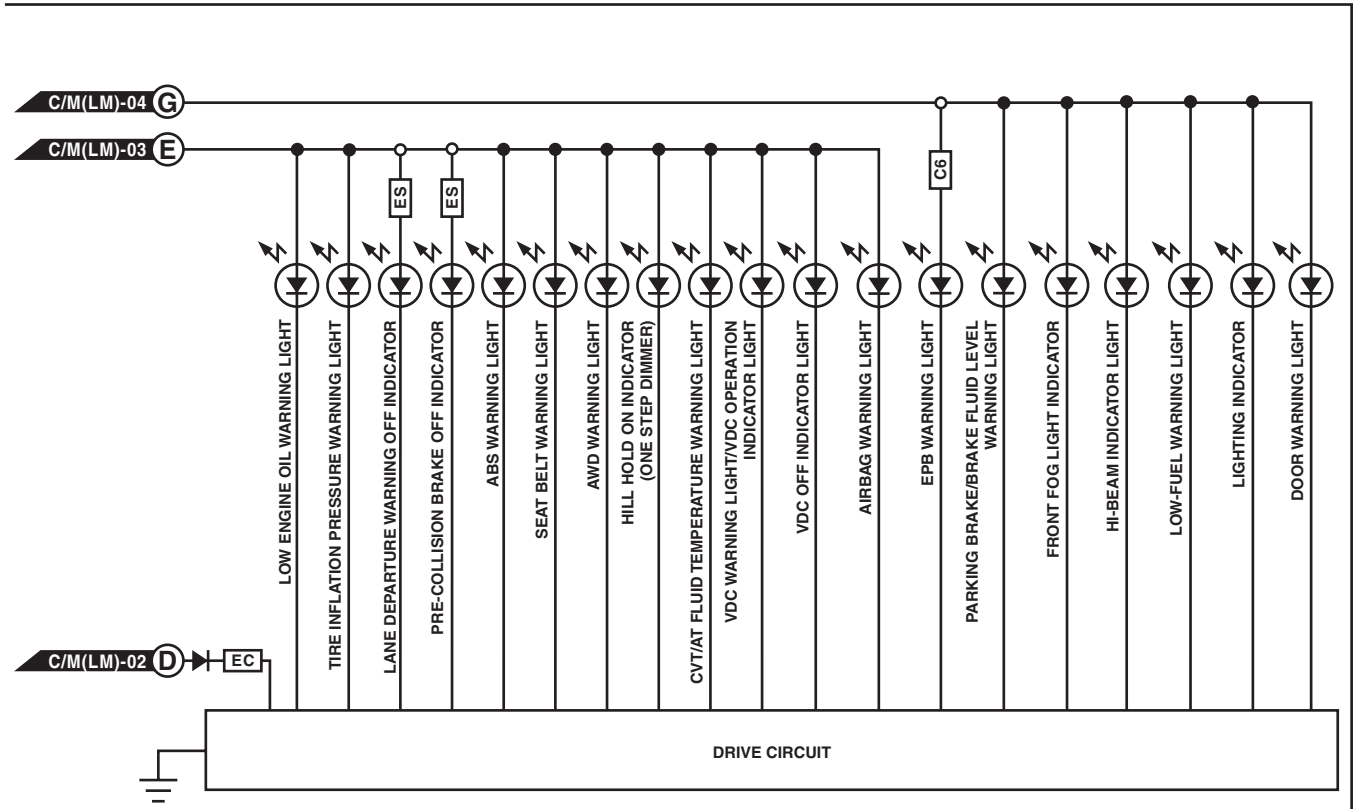

WI-36197