

Ground Circuit

WIRING SYSTEM

4. Ground Circuit A: WIRING DIAGRAM 1. CHASSIS GROUND

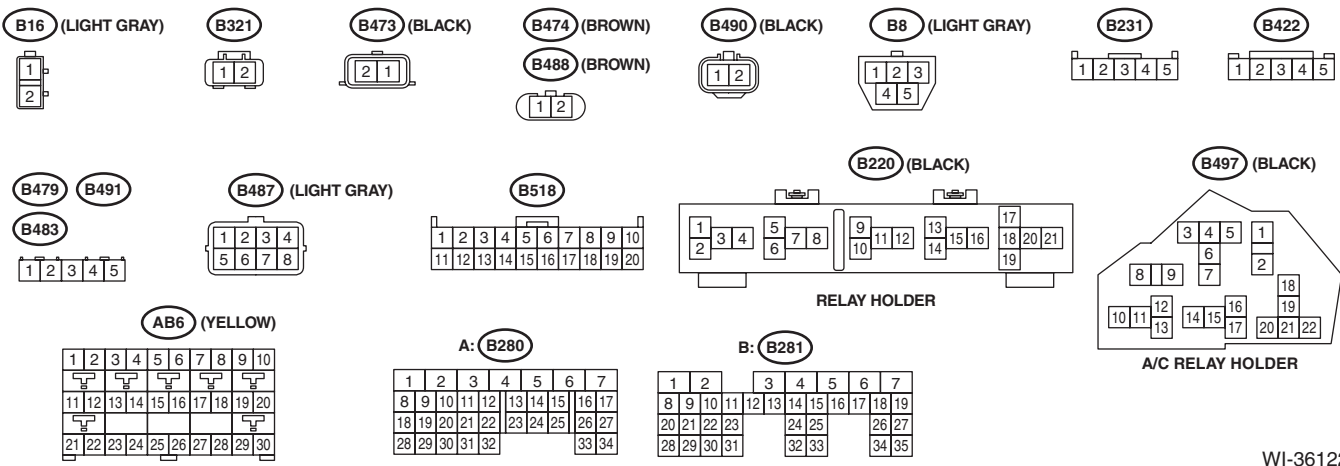
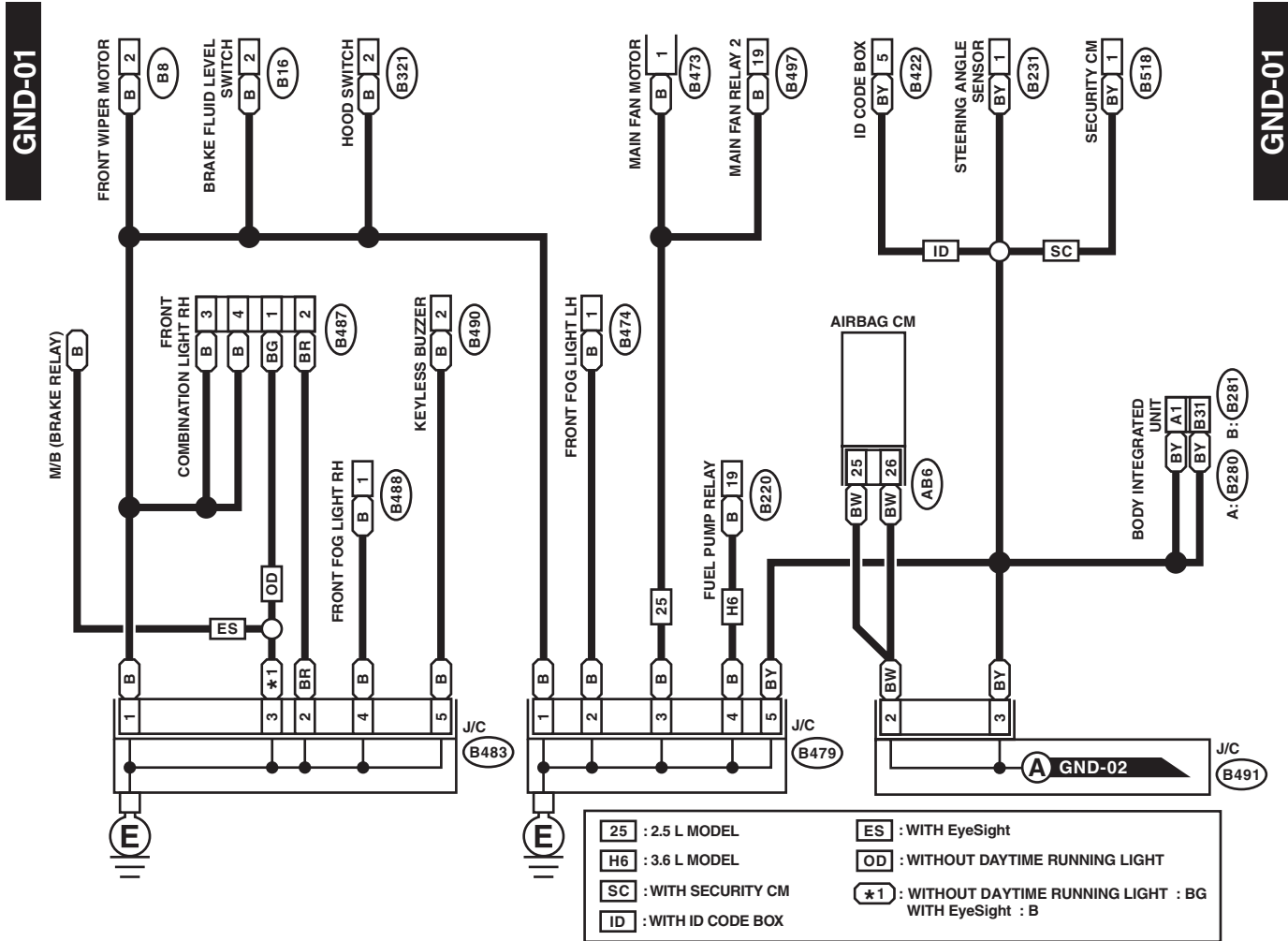

WI-36122

Ground Circuit

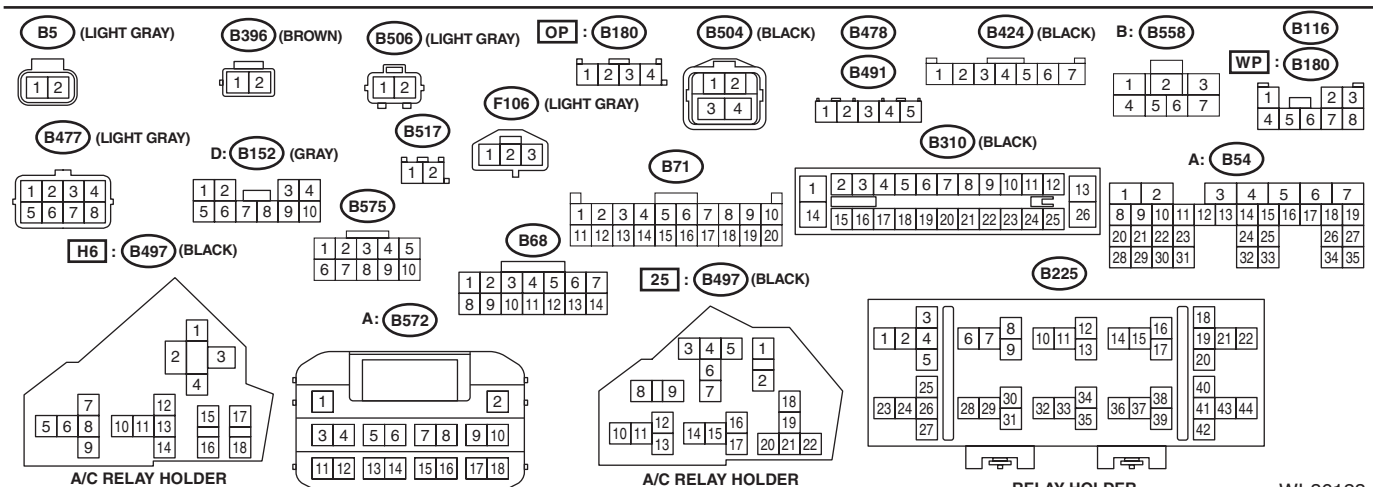
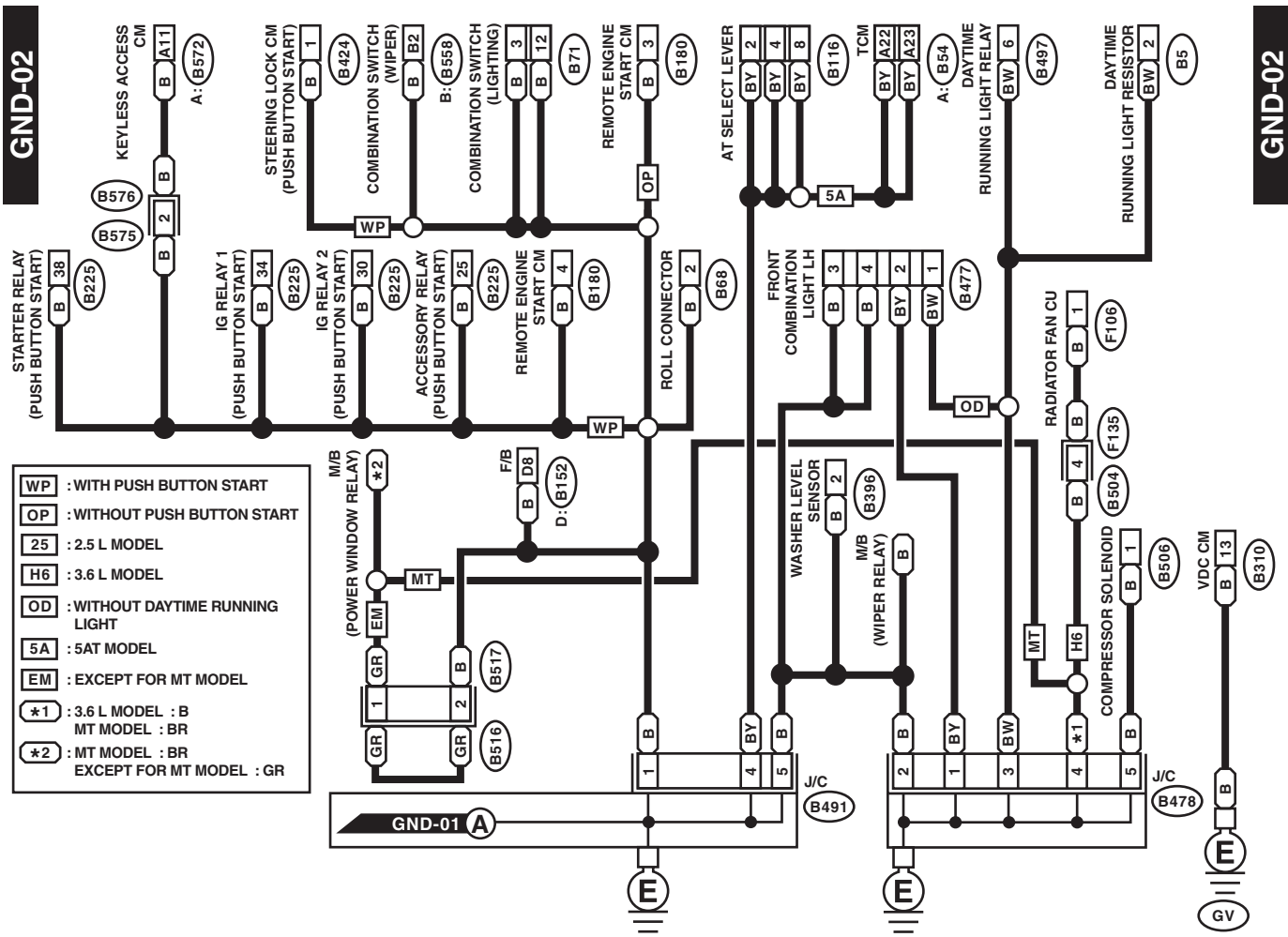

WI-36123

Ground Circuit

WIRING SYSTEM

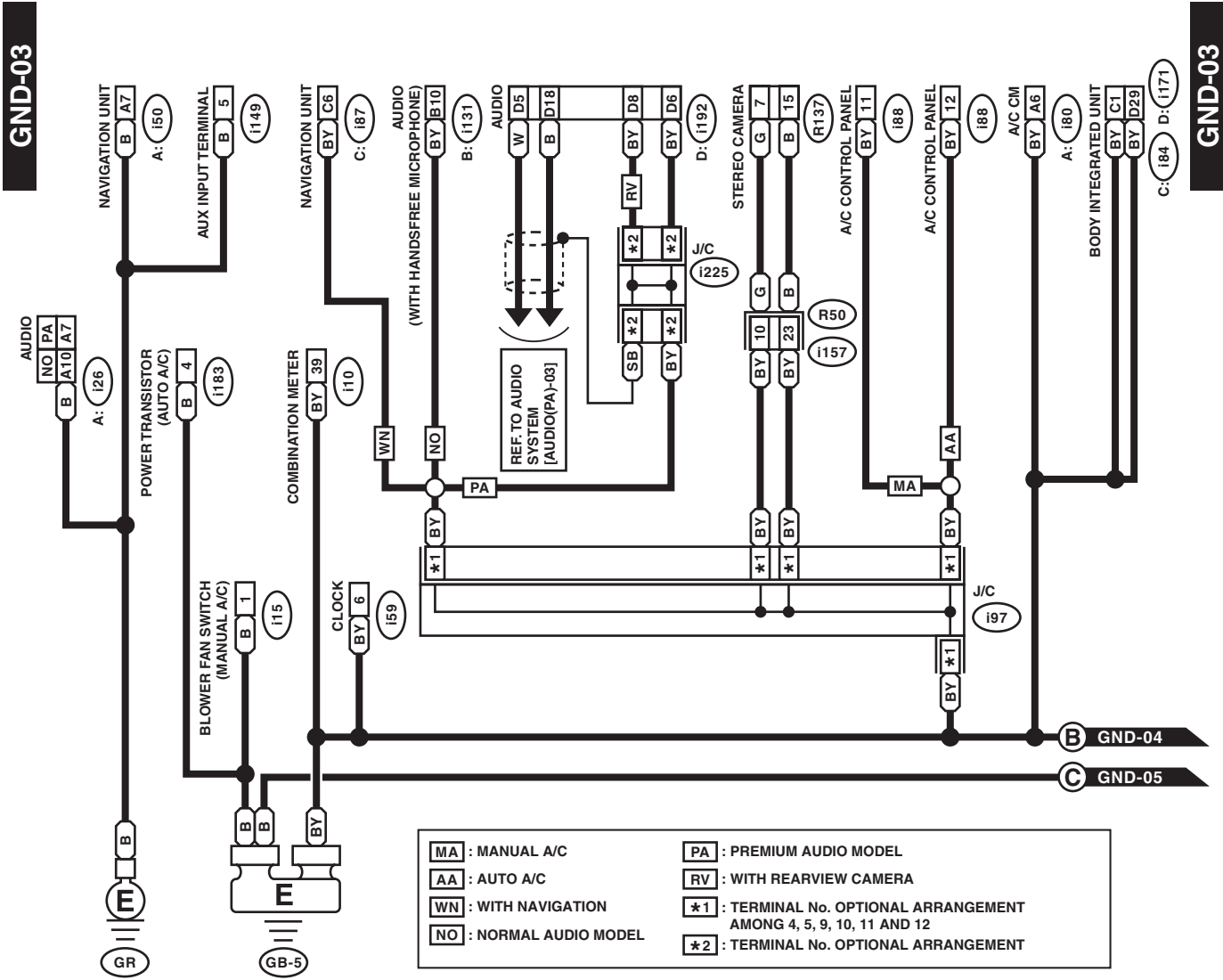

GND-03

GND-03

MA : MANUAL A/C	PA : PREMIUM AUDIO MODEL
AA : AUTO A/C	RV : WITH REARVIEW CAMERA
WN : WITH NAVIGATION	*1 : TERMINAL No. OPTIONAL ARRANGEMENT AMONG 4, 5, 9, 10, 11 AND 12
NO : NORMAL AUDIO MODEL	*2 : TERMINAL No. OPTIONAL ARRANGEMENT

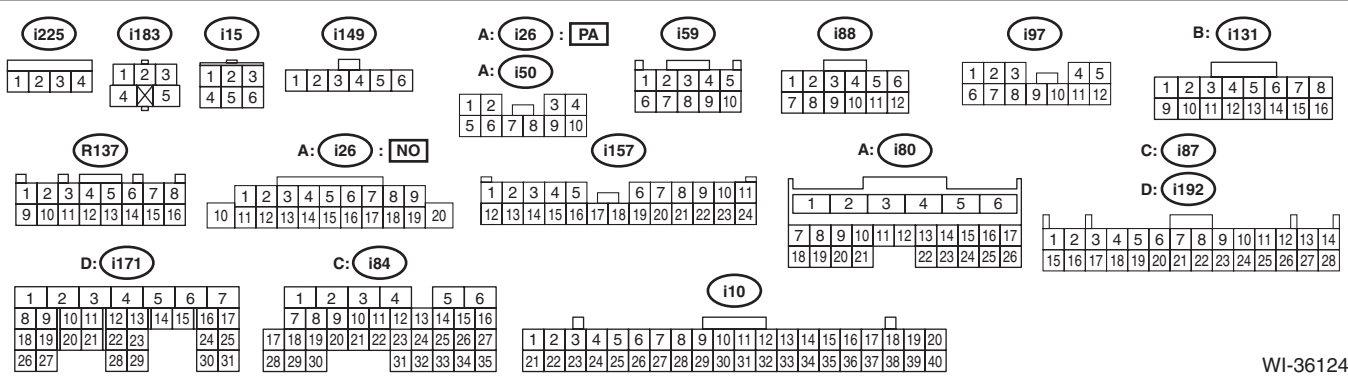

WI-36124

Ground Circuit

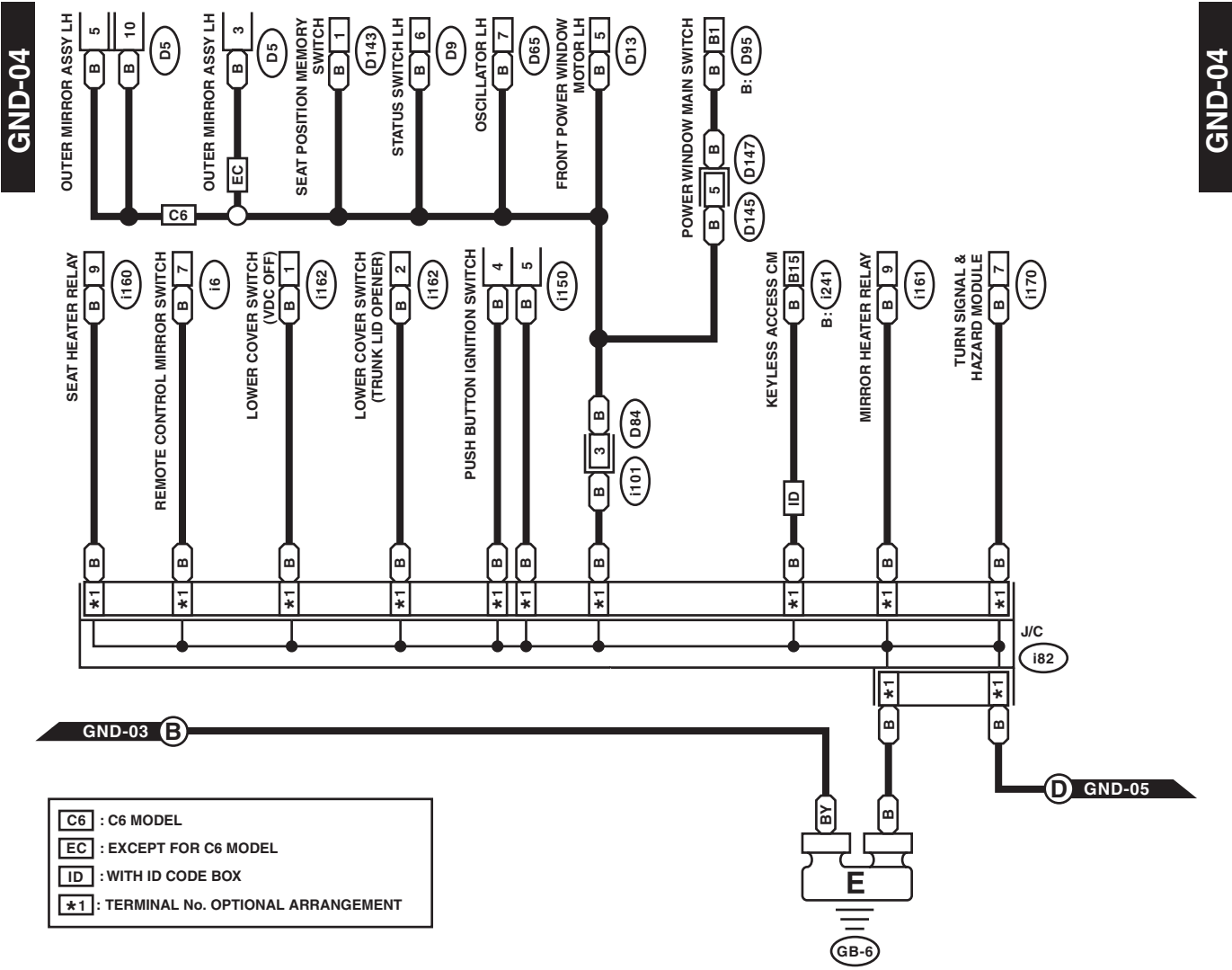

- C6** : C6 MODEL
- EC** : EXCEPT FOR C6 MODEL
- ID** : WITH ID CODE BOX
- *1** : TERMINAL No. OPTIONAL ARRANGEMENT

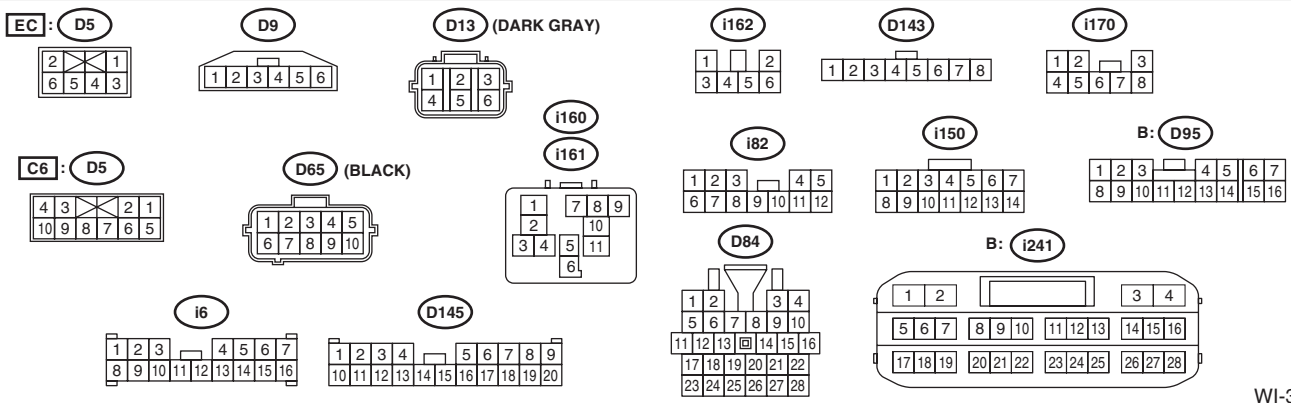

WI-36125

Ground Circuit

WIRING SYSTEM

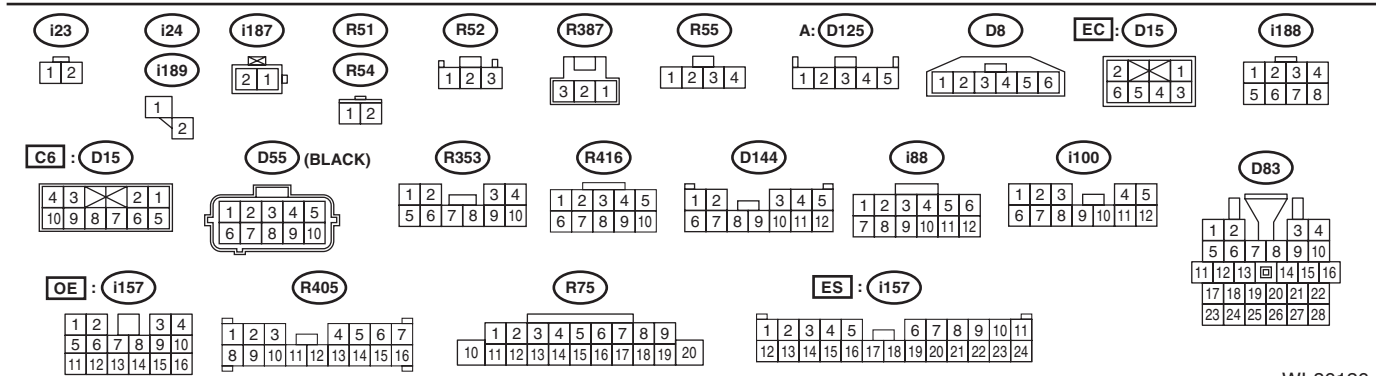
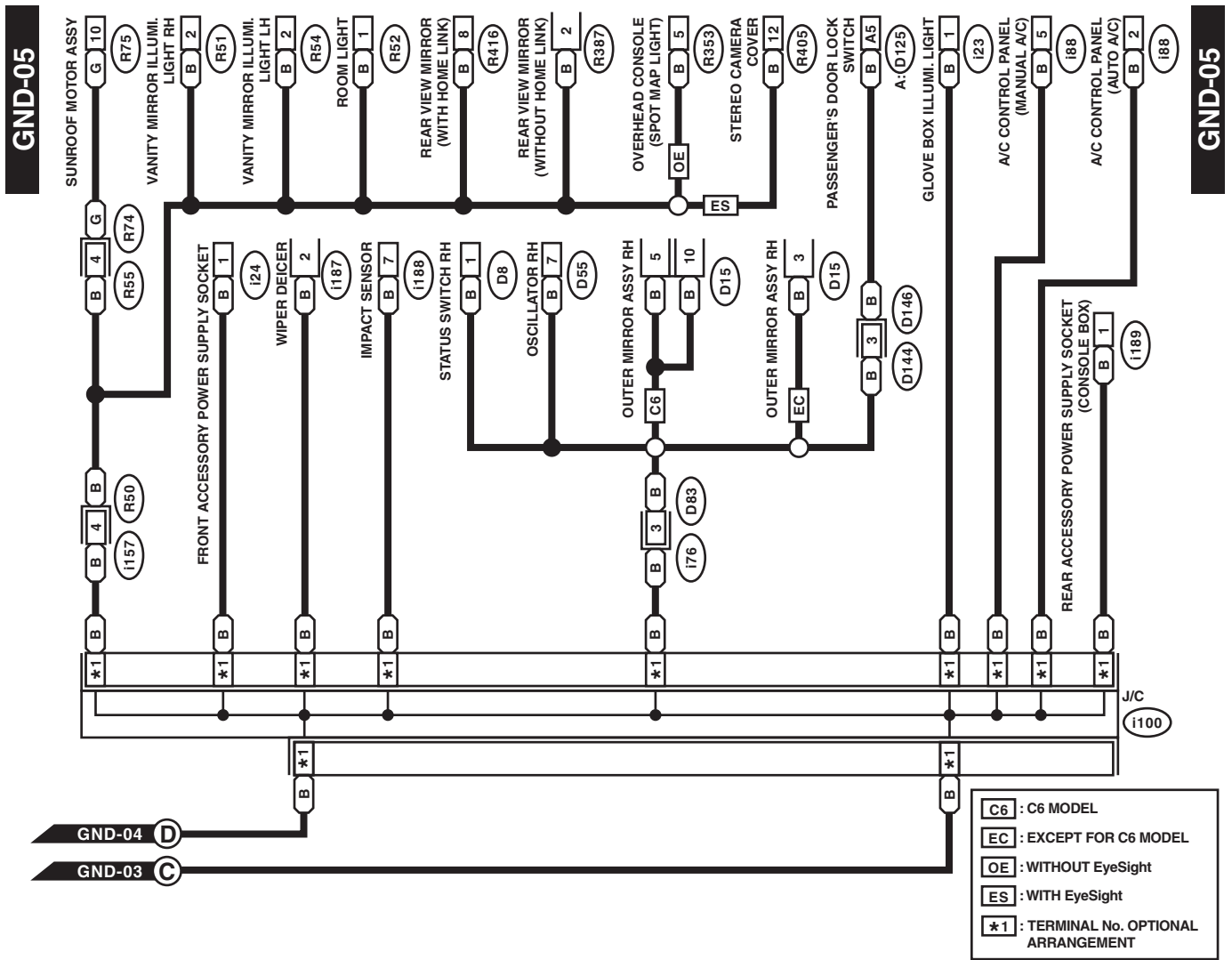

WI-36126

Ground Circuit

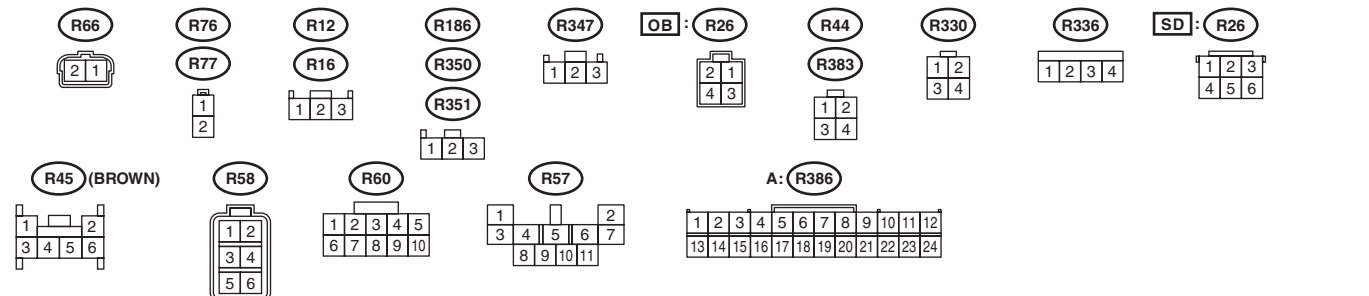
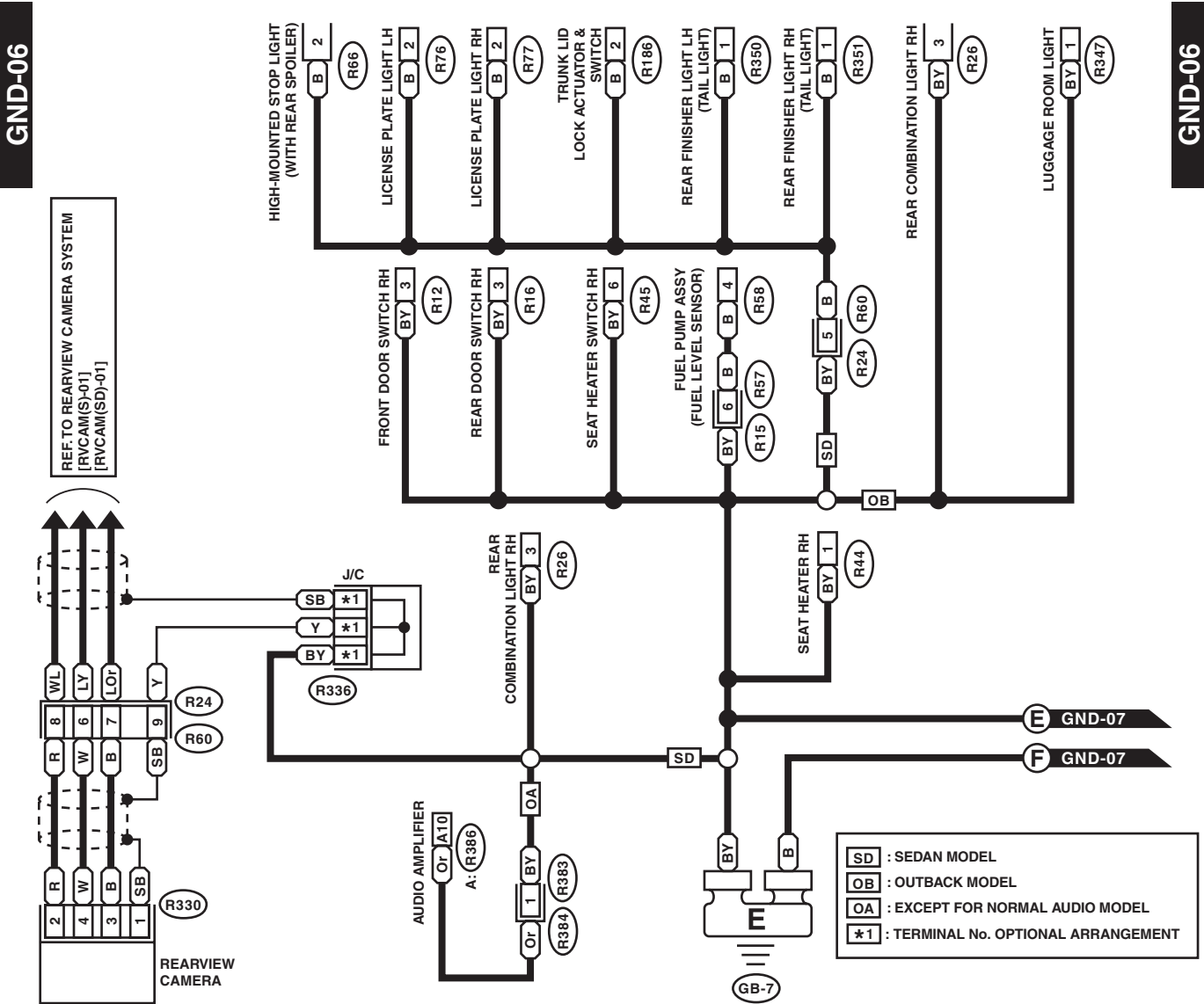

SD : SEDAN MODEL
OB : OUTBACK MODEL
OA : EXCEPT FOR NORMAL AUDIO MODEL
***1** : TERMINAL No. OPTIONAL ARRANGEMENT

GND-06

GND-06

Ground Circuit

WIRING SYSTEM

GND-07

GND-07

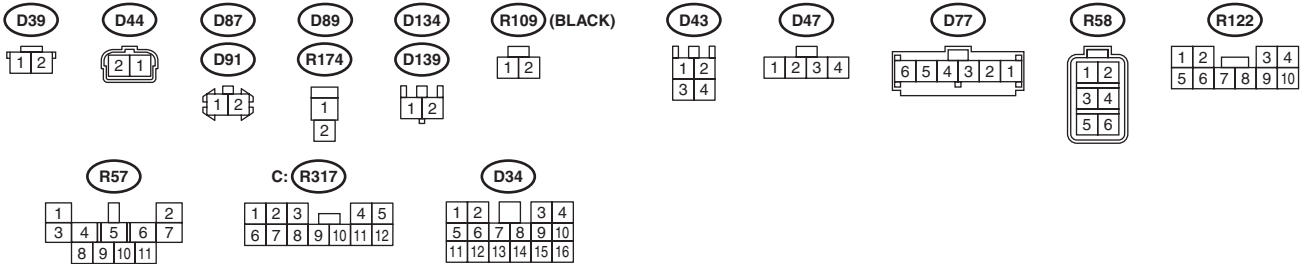
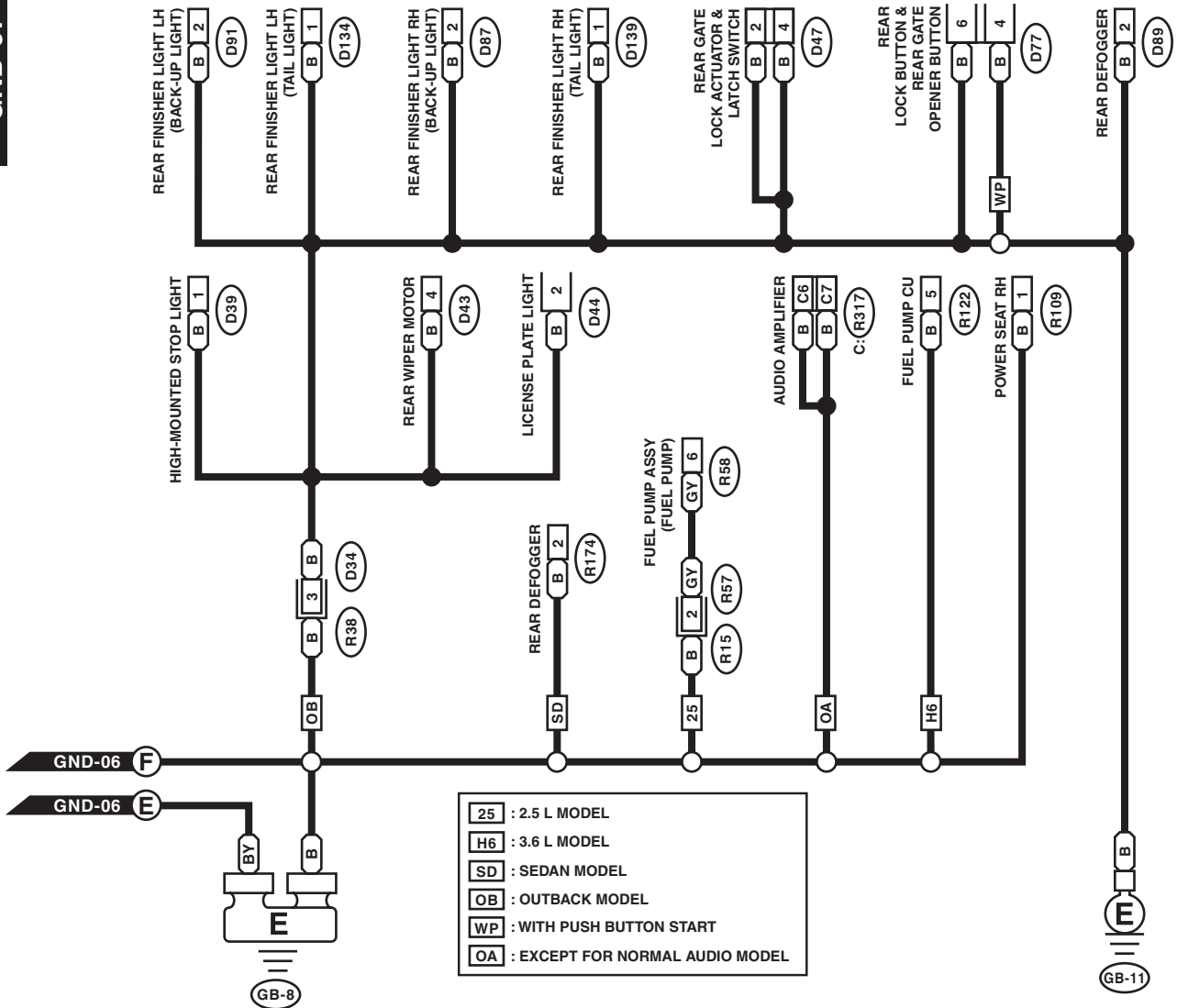

WI-36128

Ground Circuit

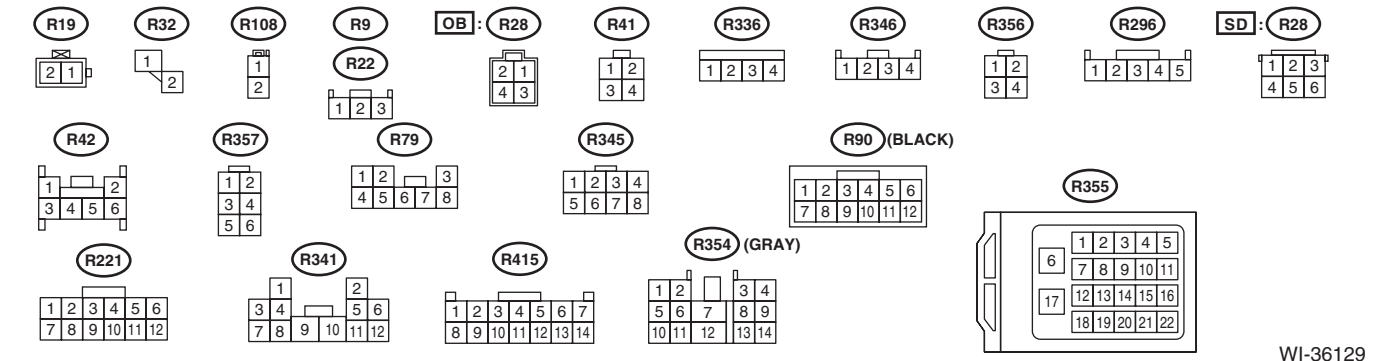
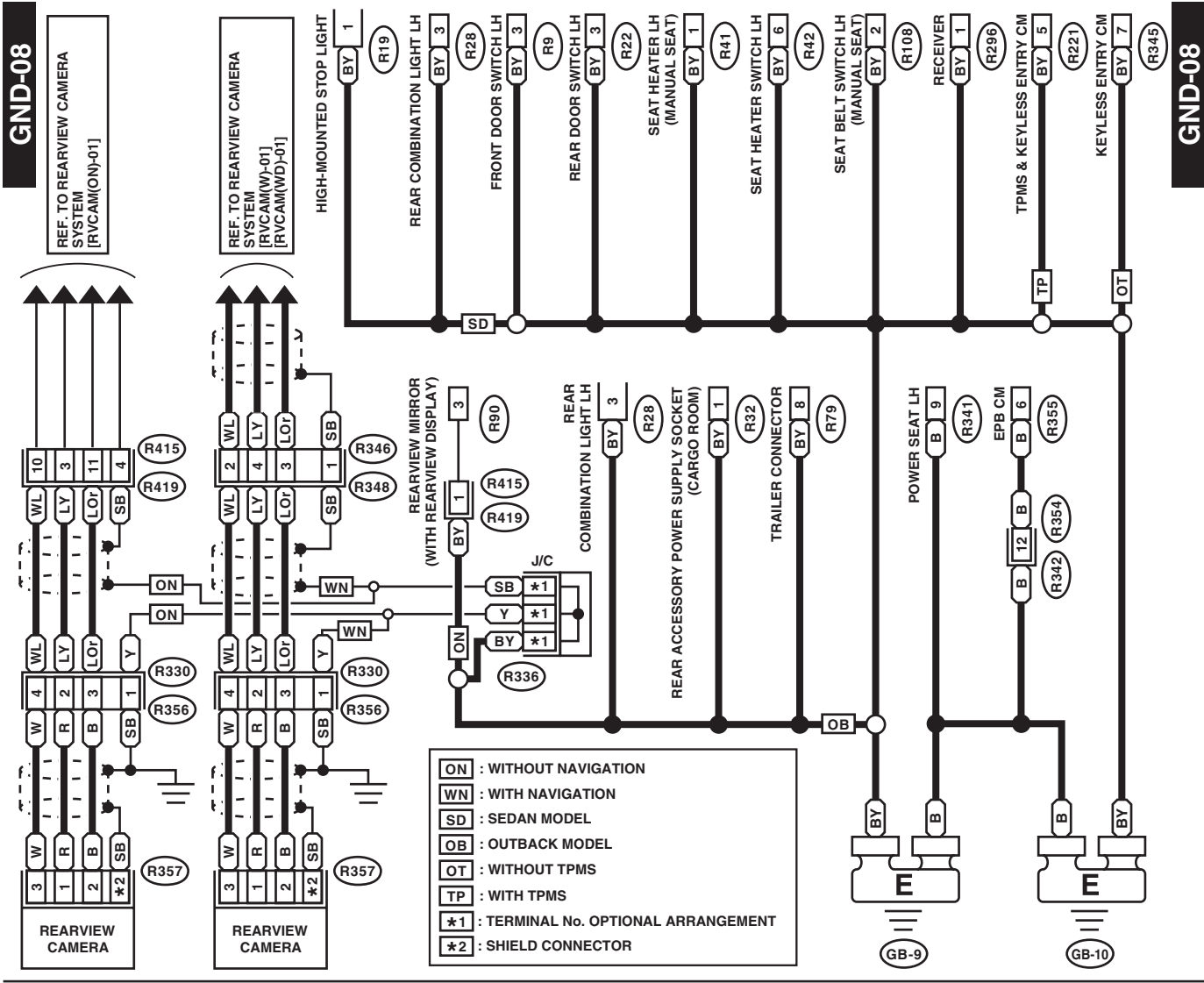

Ground Circuit

WIRING SYSTEM

2. ENGINE GROUND (2.5 L MODEL)

GND-09

GND-09

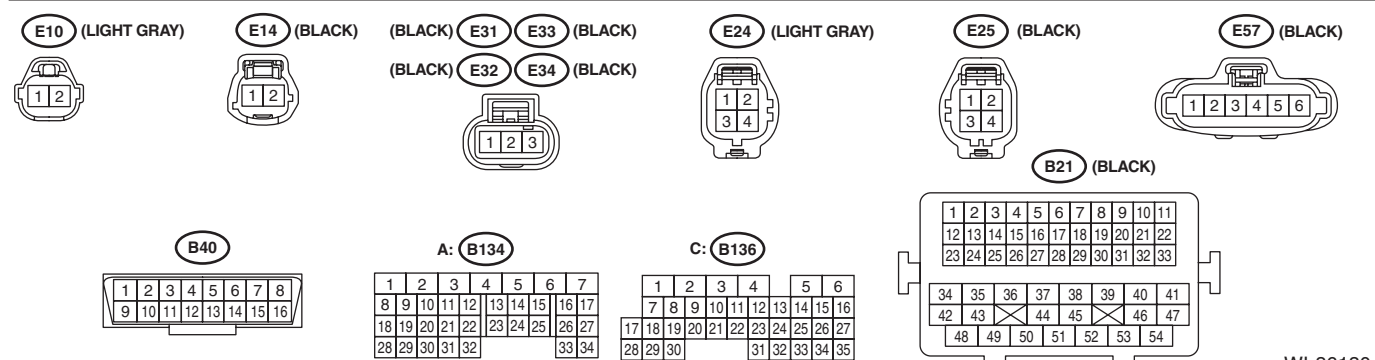
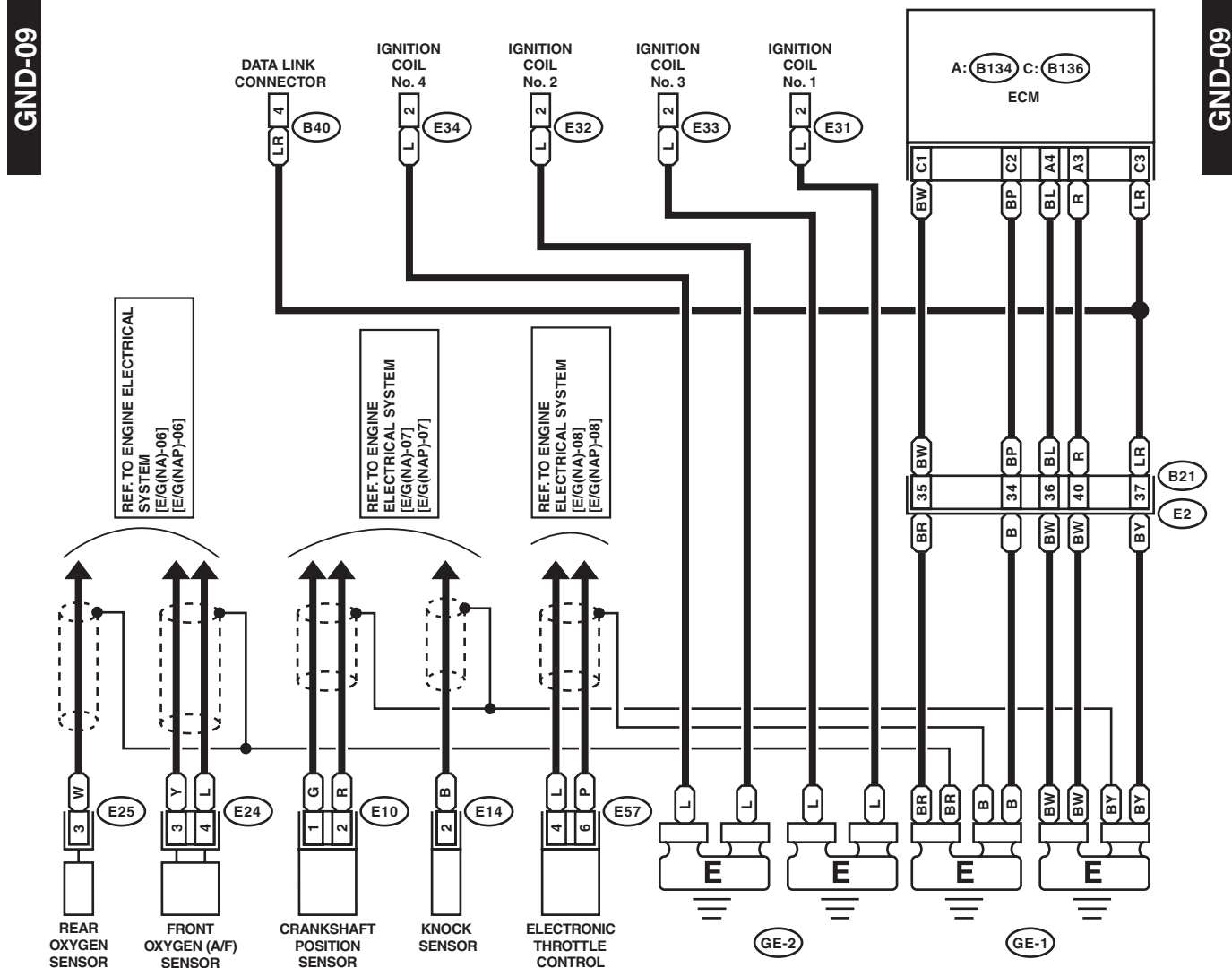

WI-36130

3. ENGINE GROUND (3.6 L MODEL)

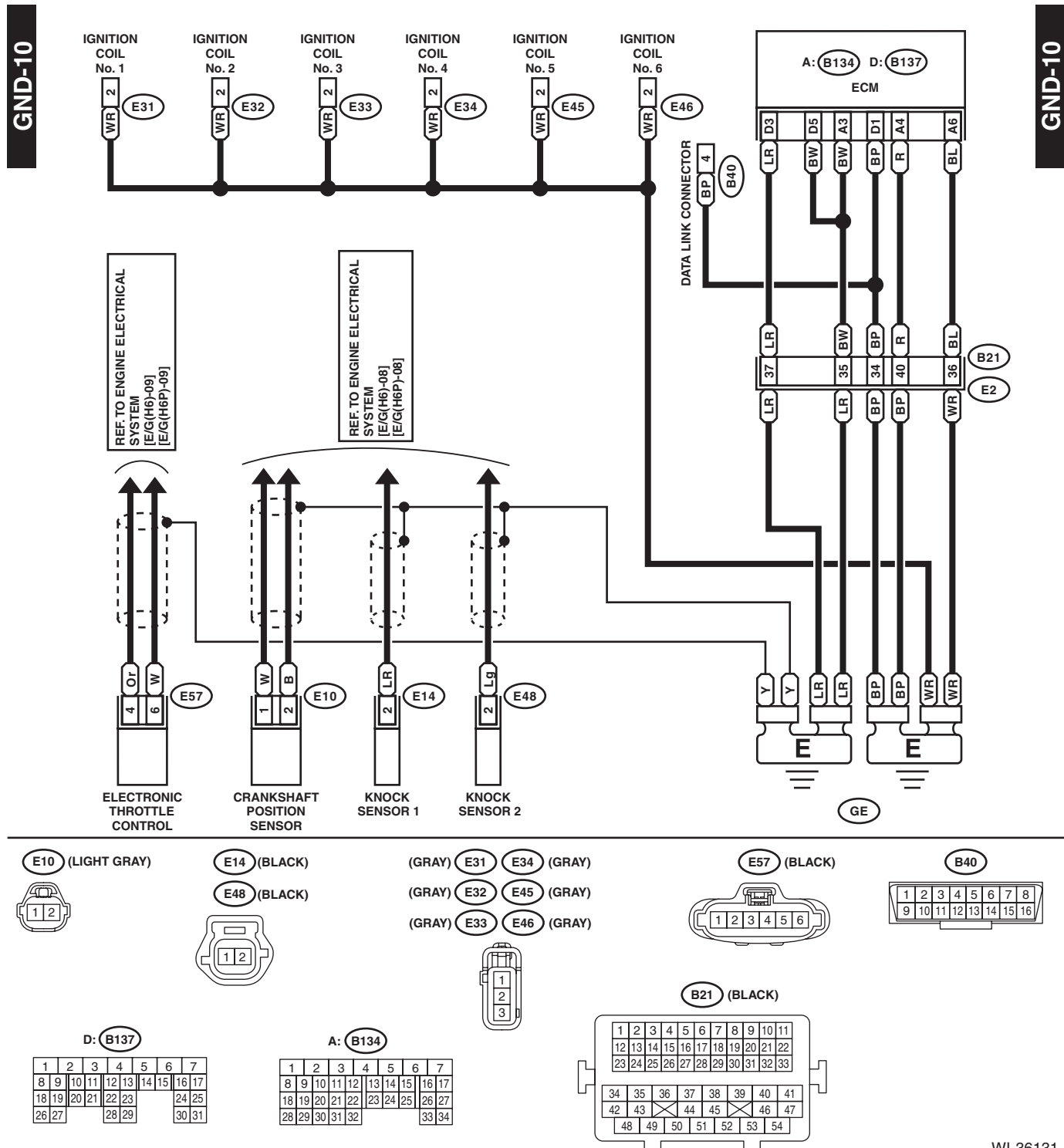

WI-36131

Ground Circuit

WIRING SYSTEM

4. TRANSMISSION GROUND (AT MODEL)

GND-11

GND-11

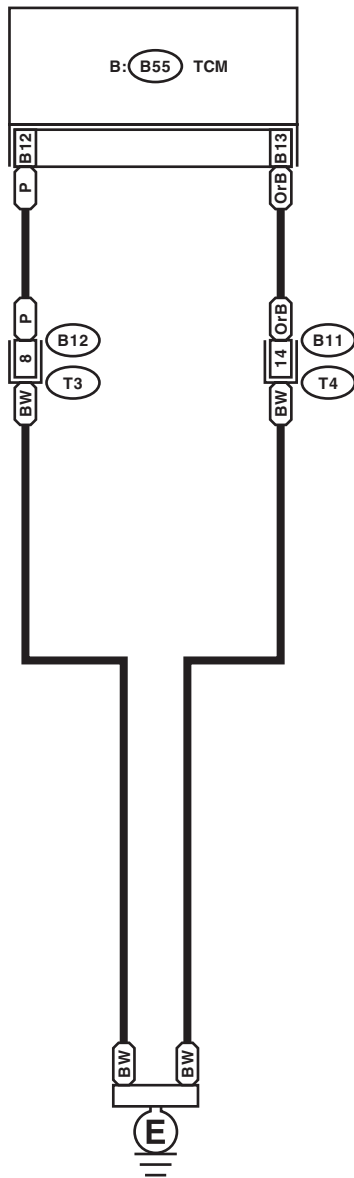

B12 (LIGHT GRAY)

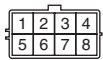

B11 (LIGHT GRAY)

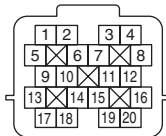

B: B55

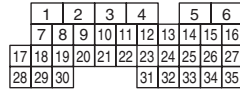

WI-36132

5. TRANSMISSION GROUND (CVT MODEL)

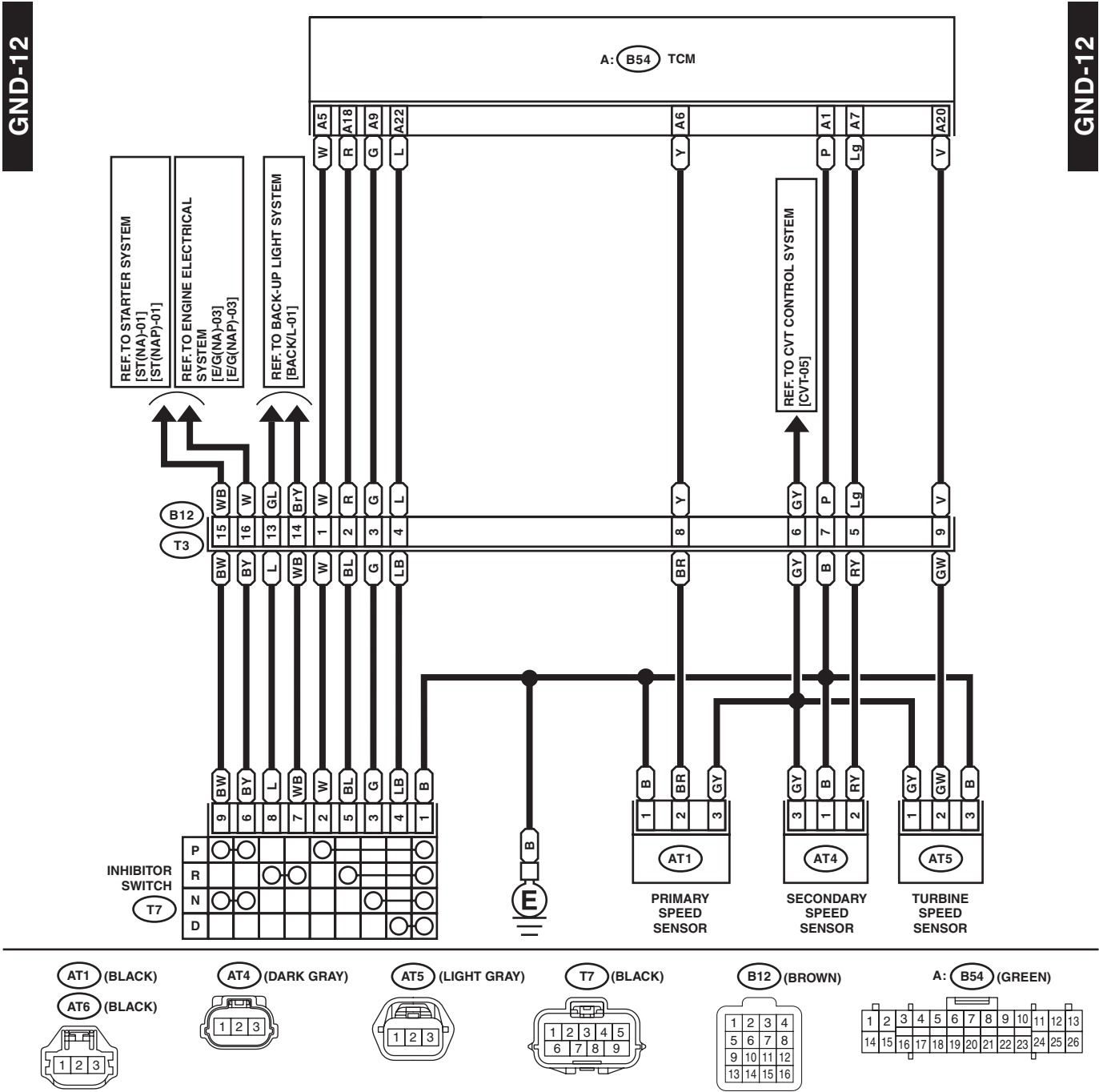

GND-12

GND-12