

## 4. Water Pump

### A: REMOVAL

#### 1. WATER PUMP PULLEY

- 1) Disconnect the ground cable from battery.

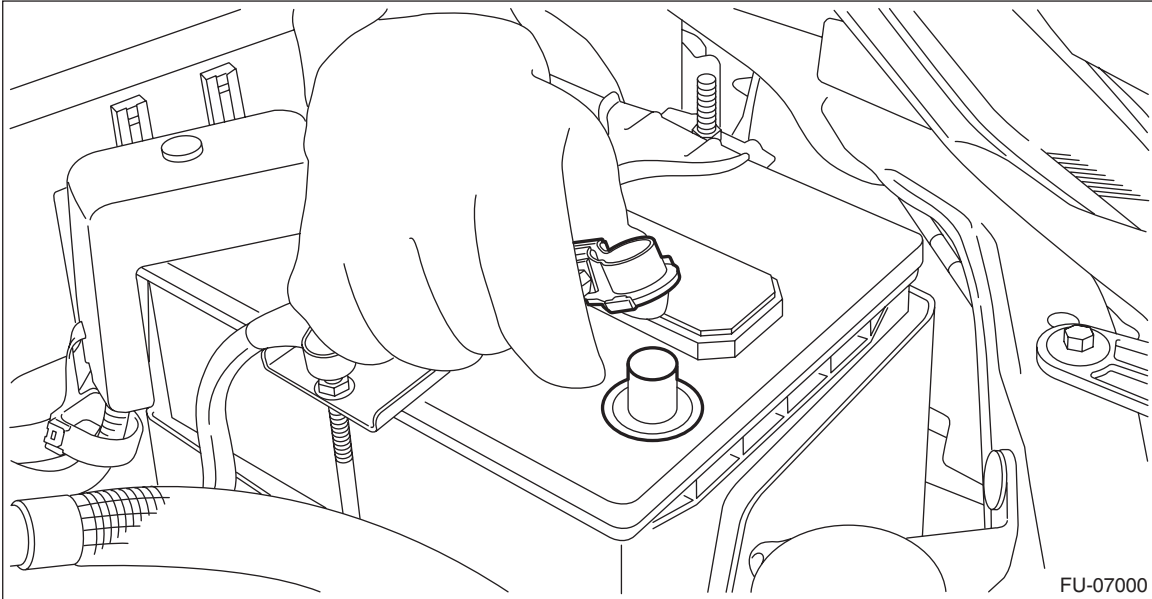

- 2) Remove the V-belts. <Ref. to ME(H4DO)-80, REMOVAL, V-belt.>
  - 3) Lift up the vehicle.
  - 4) Remove the under cover. <Ref. to EI-33, REMOVAL, Front Under Cover.>
  - 5) Remove the water pump pulley using the ST.
- ST1 1835AA000 PULLEY WRENCH  
 ST2 18334AA030 PULLEY WRENCH PIN SET

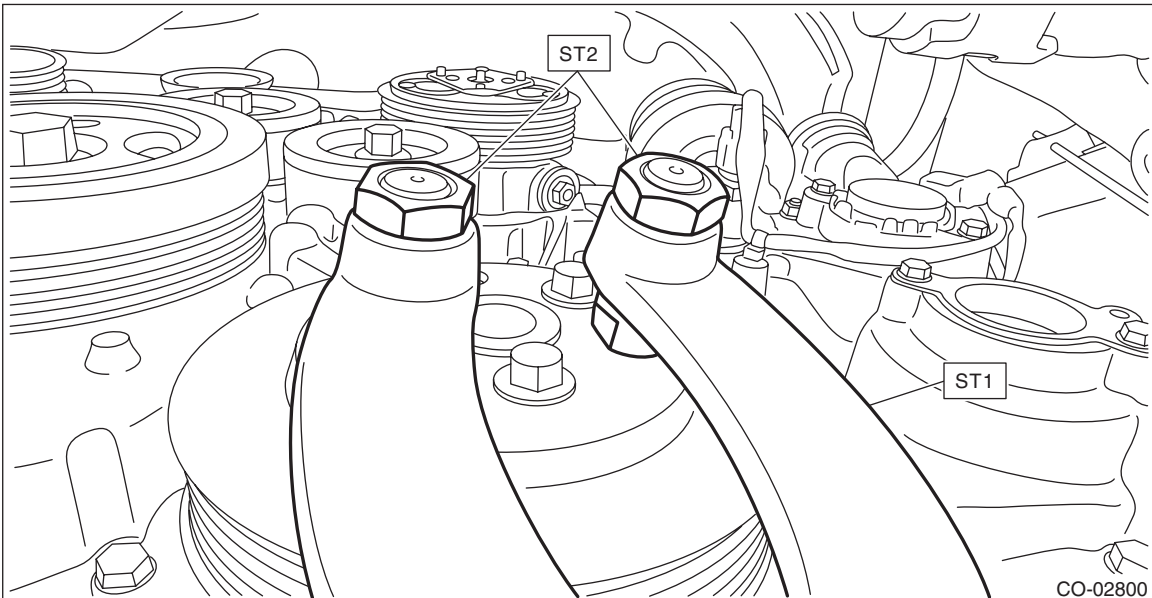

# Water Pump

## COOLING

### 2. WATER PUMP

- 1) Drain engine coolant. <Ref. to CO(H4DO)-14, DRAINING OF ENGINE COOLANT, REPLACEMENT, Engine Coolant.>
- 2) Remove the water pump pulley. <Ref. to CO(H4DO)-17, WATER PUMP PULLEY, REMOVAL, Water Pump.>
- 3) Remove the front exhaust pipe. <Ref. to EX(H4DO)-5, REMOVAL, Front Exhaust Pipe.>
- 4) Remove the water pump from the oil pan upper.

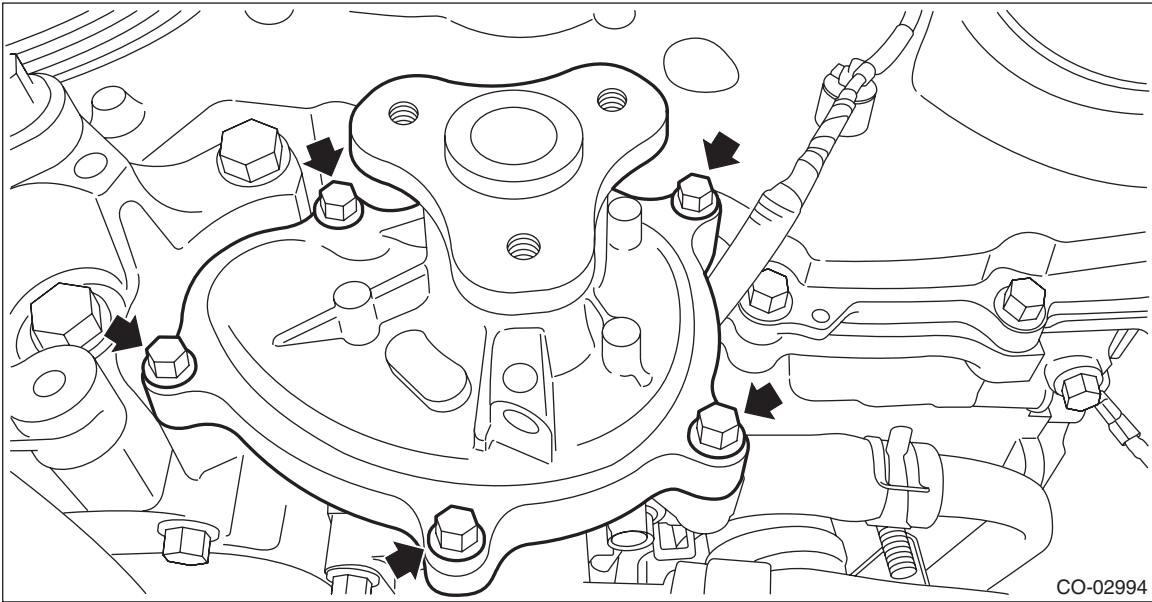

### B: INSTALLATION

#### 1. WATER PUMP PULLEY

- 1) Using the ST, install the water pump pulley.  
ST1 18355AA000 PULLEY WRENCH  
ST2 18334AA030 PULLEY WRENCH PIN SET

**Tightening torque:**

**14 N·m (1.4 kgf·m, 10.3 ft·lb)**

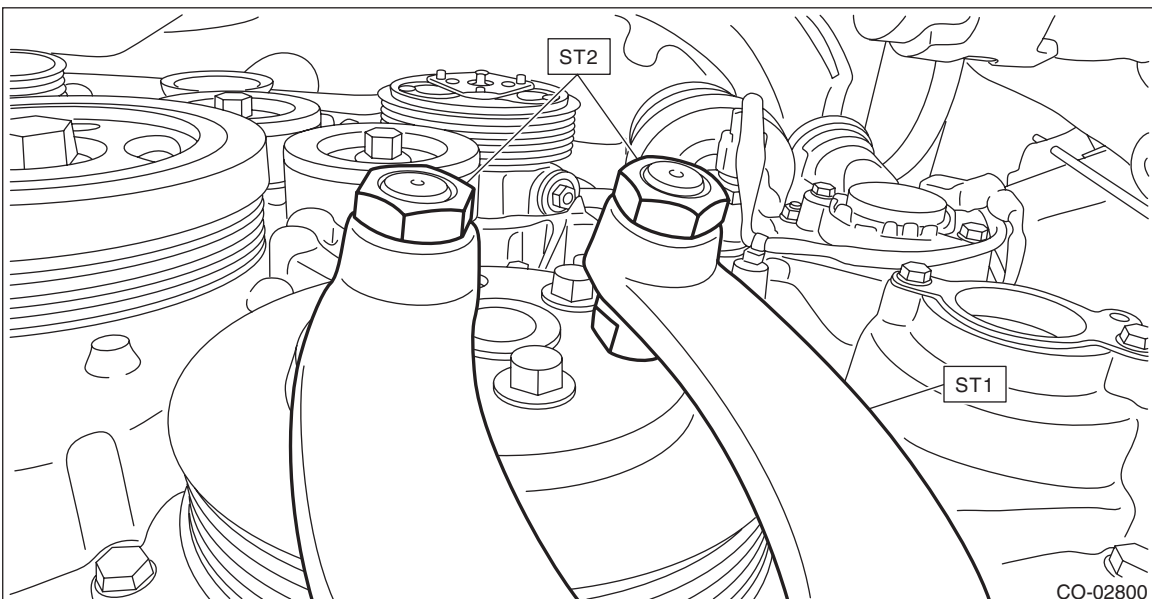

- 2) Install the under cover. <Ref. to EI-33, INSTALLATION, Front Under Cover.>
- 3) Lower the vehicle.

- 4) Install the V-belts. <Ref. to ME(H4DO)-82, INSTALLATION, V-belt.>
- 5) Connect the battery ground terminal.

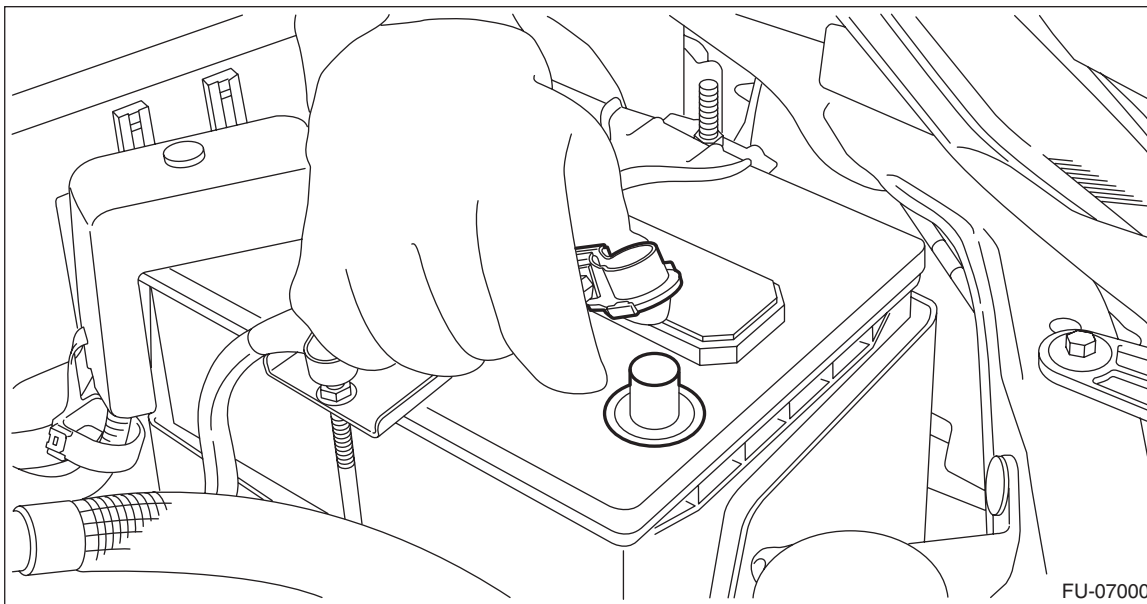

FU-07000

## 2. WATER PUMP

- 1) Install the water pump to oil pan upper.

NOTE:

Use a new gasket.

**Tightening torque:**

**6.4 N·m (0.7 kgf-m, 4.7 ft-lb)**

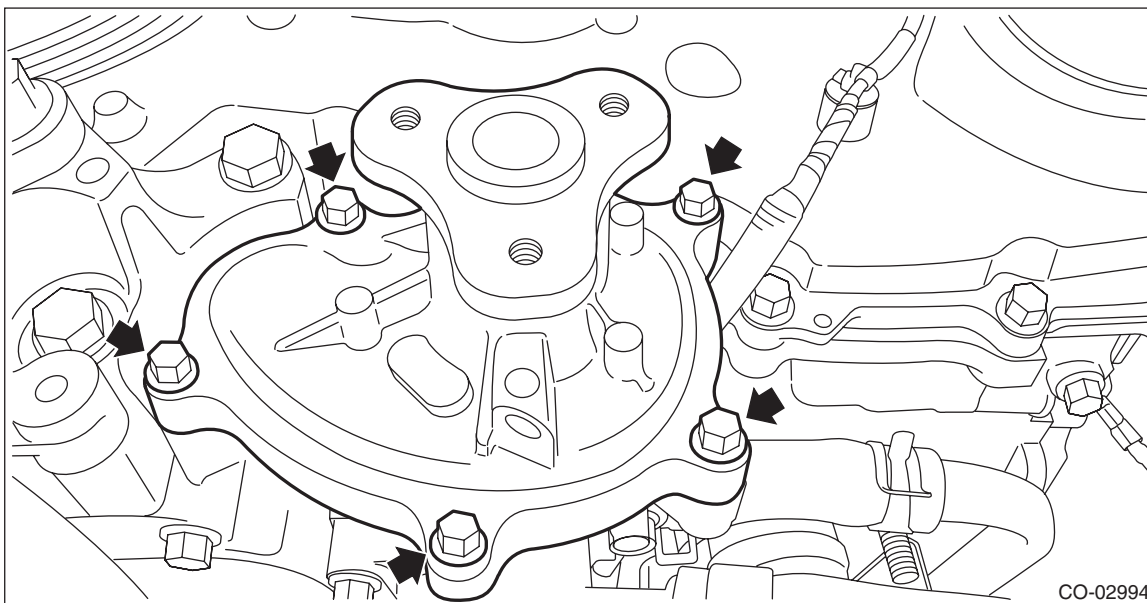

CO-02994

- 2) Install the front exhaust pipe. <Ref. to EX(H4DO)-8, INSTALLATION, Front Exhaust Pipe.>
- 3) Install the water pump pulley. <Ref. to CO(H4DO)-18, WATER PUMP PULLEY, INSTALLATION, Water Pump.>
- 4) Fill engine coolant. <Ref. to CO(H4DO)-15, FILLING OF ENGINE COOLANT, REPLACEMENT, Engine Coolant.>

# Water Pump

COOLING

---

## **C: INSPECTION**

- 1) Check the water pump bearing for smooth rotation.
- 2) Check the water pump pulley for abnormalities.
- 3) Make sure the impeller is not abnormally deformed or damaged.