

Drain Filter

EMISSION CONTROL (AUX. EMISSION CONTROL DEVICES)

10.Drain Filter

A: REMOVAL

- 1) Remove the rear sub frame. <Ref. to RS-16, REMOVAL, Rear Sub Frame.>
- 2) Disconnect the drain tube assembly from the canister tube assembly, and remove the drain tube assembly from the tube clamp (A).

NOTE:

Disconnect the quick connector as shown in the figure.

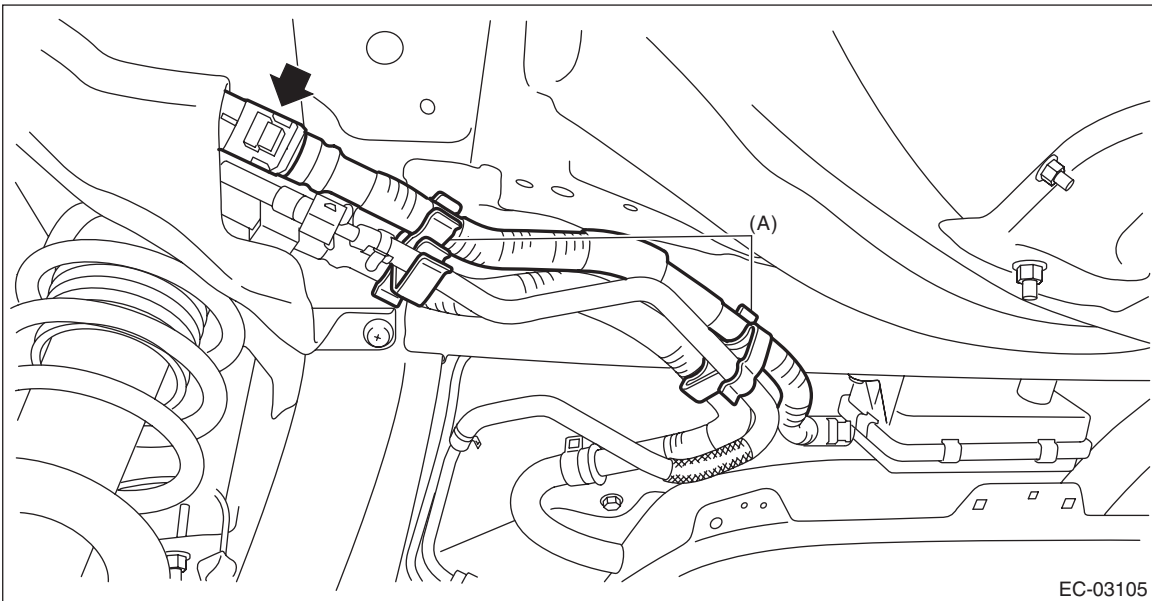
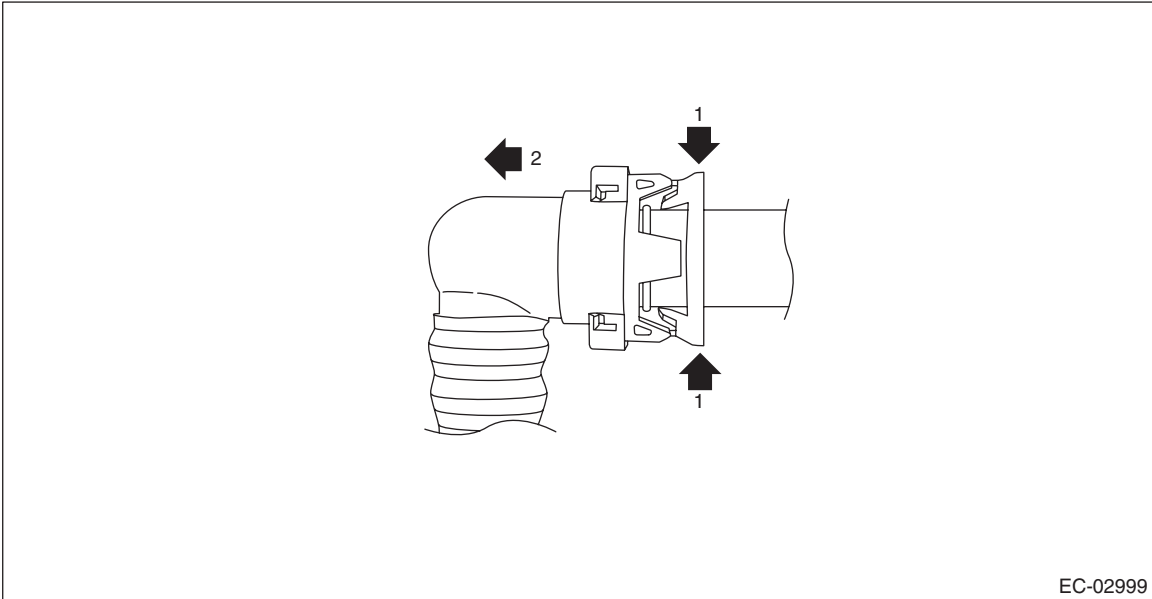

Drain Filter

EMISSION CONTROL (AUX. EMISSION CONTROL DEVICES)

- 3) Remove the drain filter together with the drain tube assembly from the vehicle.

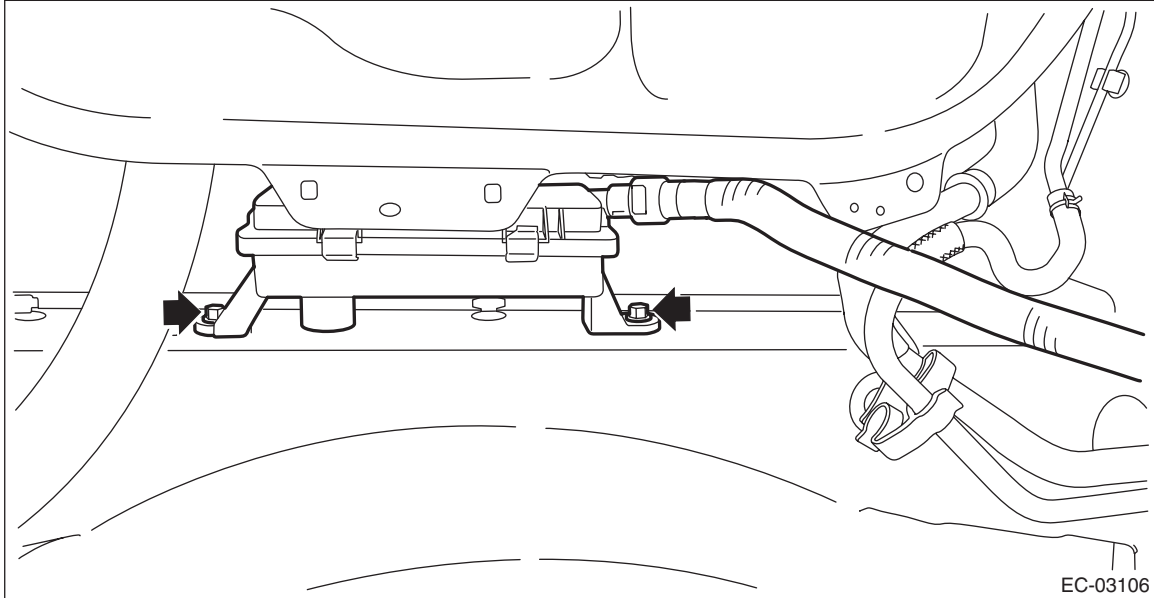

Drain Filter

EMISSION CONTROL (AUX. EMISSION CONTROL DEVICES)

4) Remove the drain tube assembly from the drain filter.

NOTE:

Disconnect the quick connector as shown in the figure.

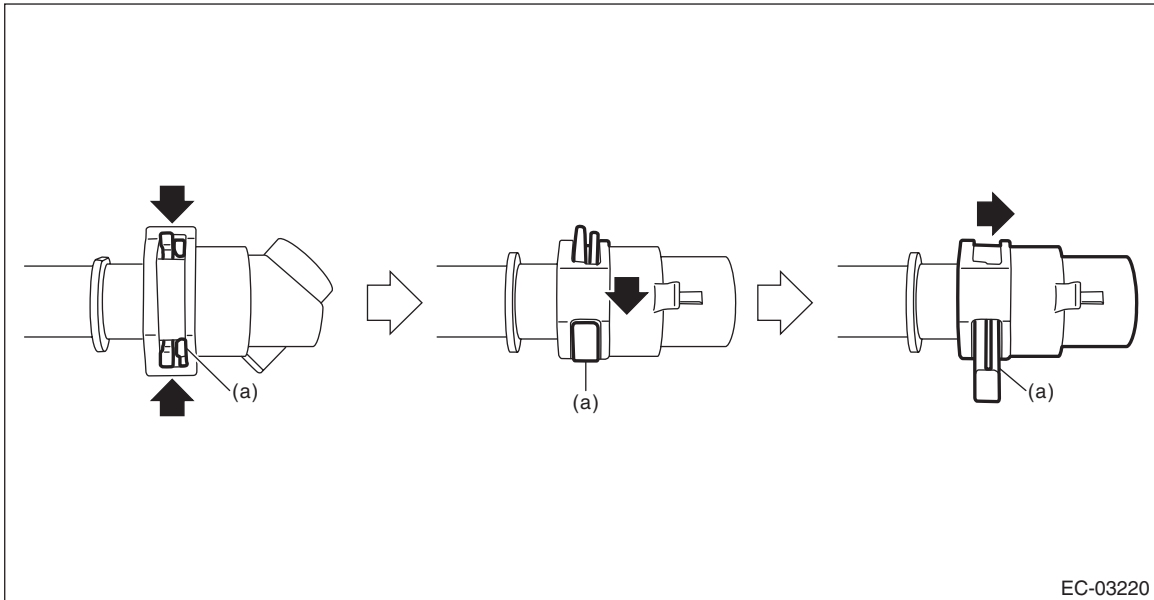

(a) Retainer

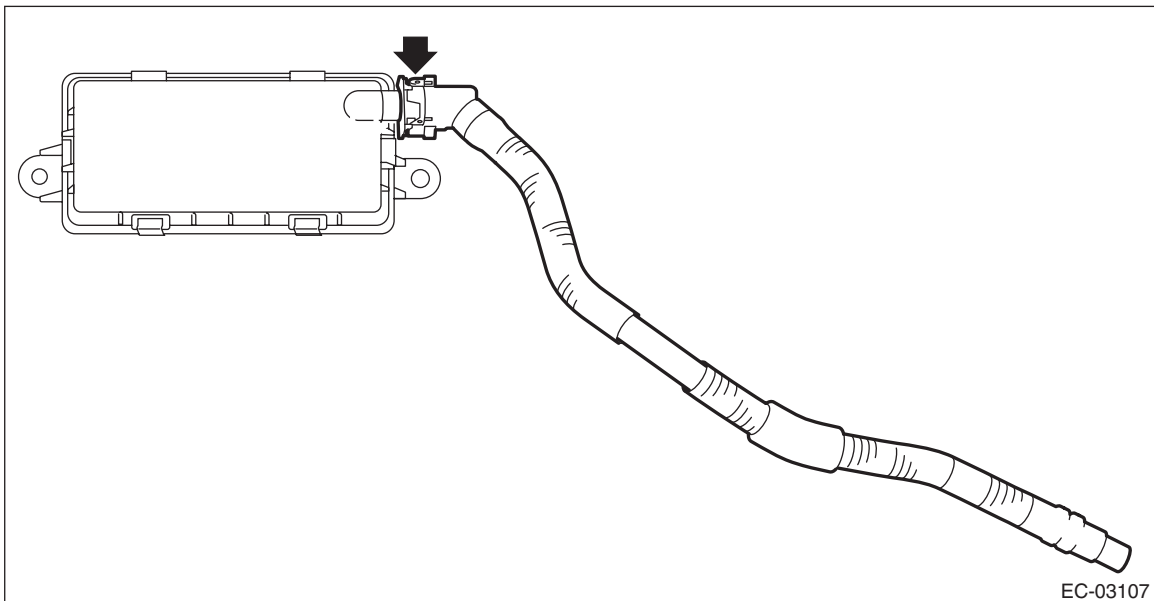

Drain Filter

EMISSION CONTROL (AUX. EMISSION CONTROL DEVICES)

B: INSTALLATION

1) Install the drain tube assembly to the drain filter.

CAUTION:

- Make sure there are no damage or dust on connections. If necessary, clean the seal surface of the pipe.
- Make sure that the quick connector is securely connected.

NOTE:

Connect the quick connector as shown in the figure.

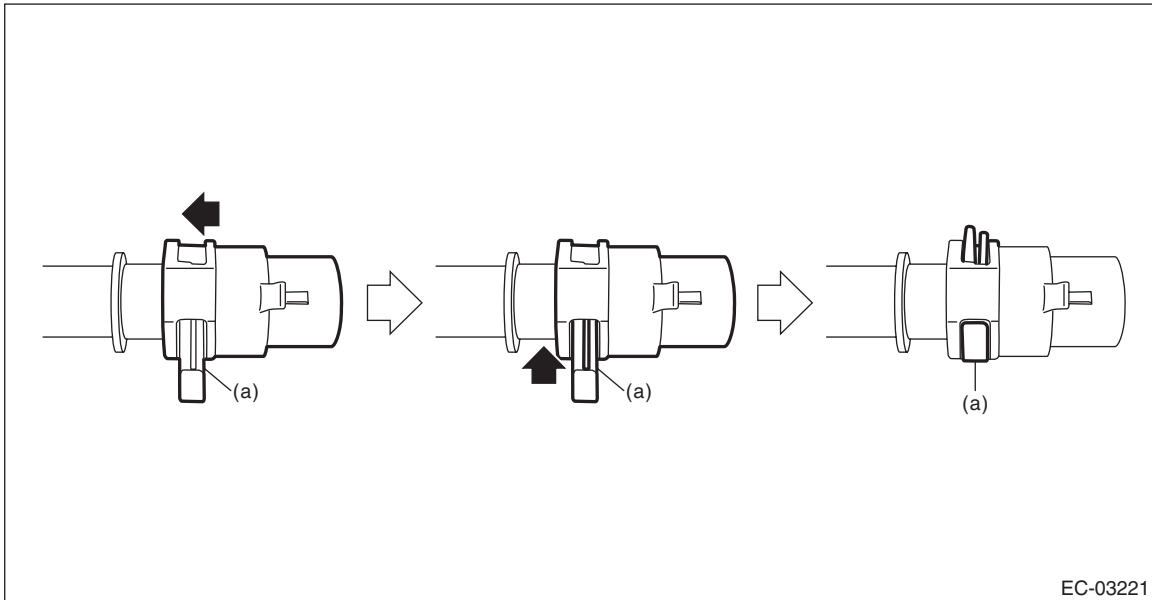

(a) Retainer

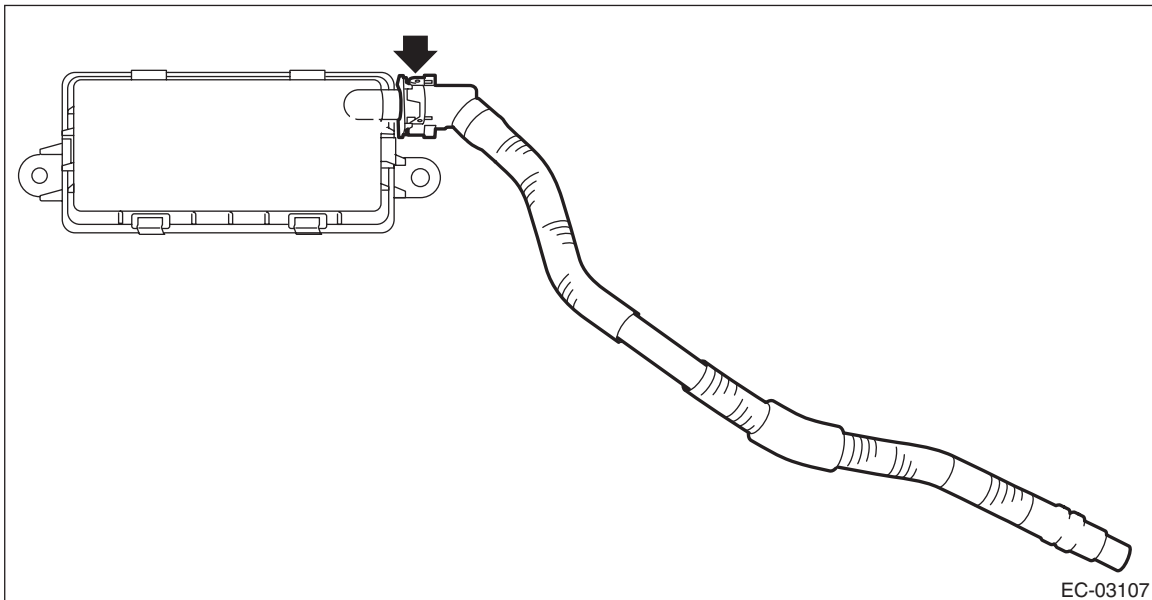

Drain Filter

EMISSION CONTROL (AUX. EMISSION CONTROL DEVICES)

2) Install the drain filter together with the drain tube assembly to the vehicle.

Tightening torque:

7.5 N·m (0.8 kgf-m, 5.5 ft-lb)

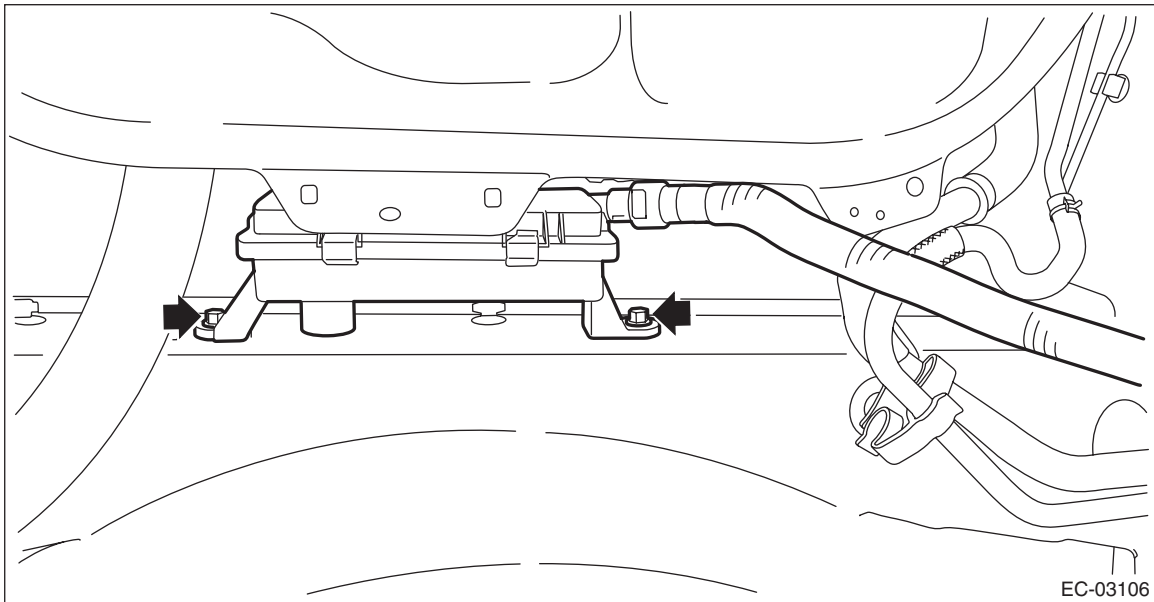

EC-03106

Drain Filter

EMISSION CONTROL (AUX. EMISSION CONTROL DEVICES)

3) Connect the drain tube assembly to the canister tube assembly, and install the drain tube assembly to the tube clamp (A).

CAUTION:

- Make sure there are no damage or dust on connections. If necessary, clean the seal surface of the pipe.
- Make sure that the quick connector is securely connected.

NOTE:

Connect the quick connector as shown in the figure.

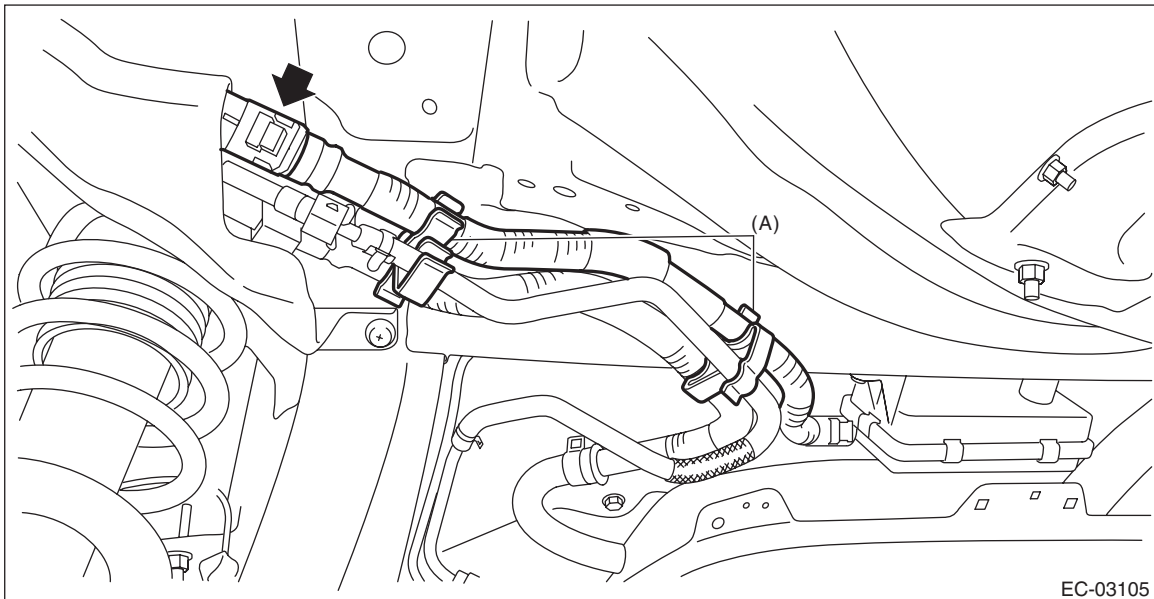
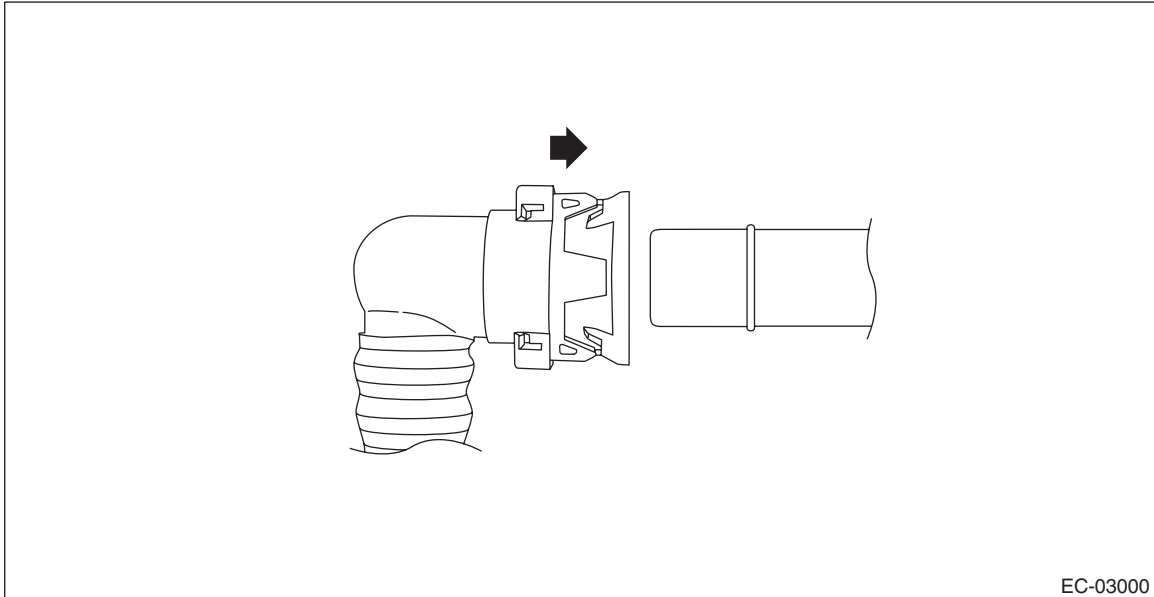

4) Install the rear sub frame. <Ref. to RS-18, INSTALLATION, Rear Sub Frame.>

C: INSPECTION

- 1) Check that the drain filter and drain tube assembly have no deformation, cracks or other damages.
- 2) Check that no foreign substances are clogged in the drain filter.