

# Leak Check Valve Assembly

EMISSION CONTROL (AUX. EMISSION CONTROL DEVICES)

## 11. Leak Check Valve Assembly

### A: SPECIFICATION

Leak check valve assembly cannot be disassembled.

Refer to "Canister" for removal and installation procedures. <Ref. to EC(H4DO)-9, REMOVAL, Canister.>

<Ref. to EC(H4DO)-13, INSTALLATION, Canister.>

### B: INSPECTION

#### 1. CHECK SWITCHING VALVE

1) Check the resistance between switching valve terminals.

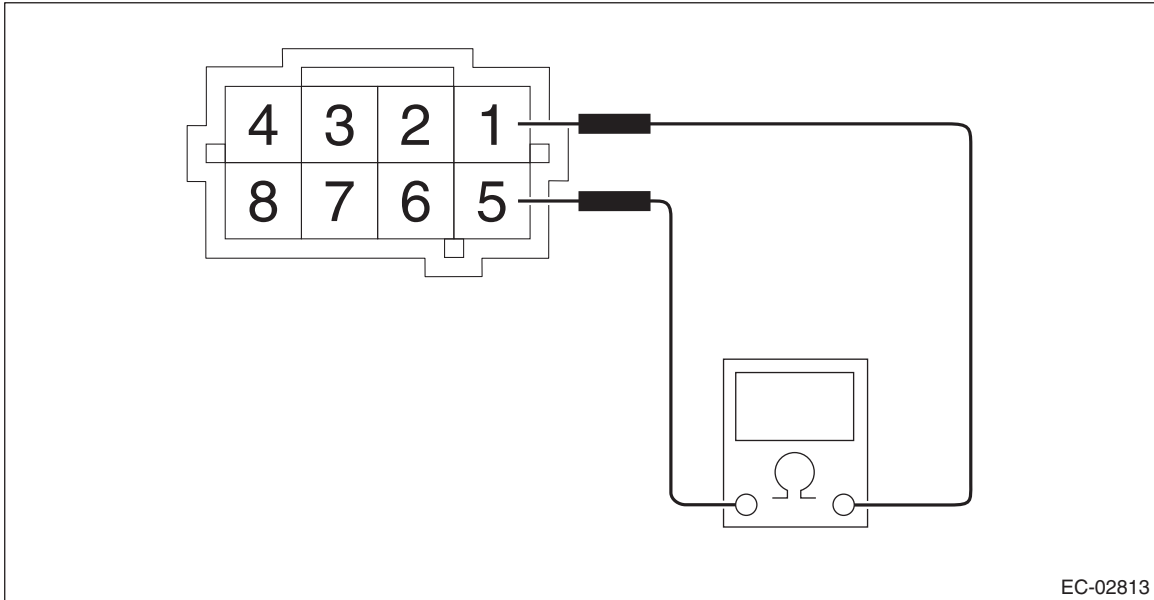

Terminal No.	Standard
1 and 5	$27^{+3}_{-2} \Omega$ (when 20°C (68°F))
	$31 \pm 4 \Omega$ (60°C (140°F))

2) Check that air is discharged from (B) when air is blown into (A).

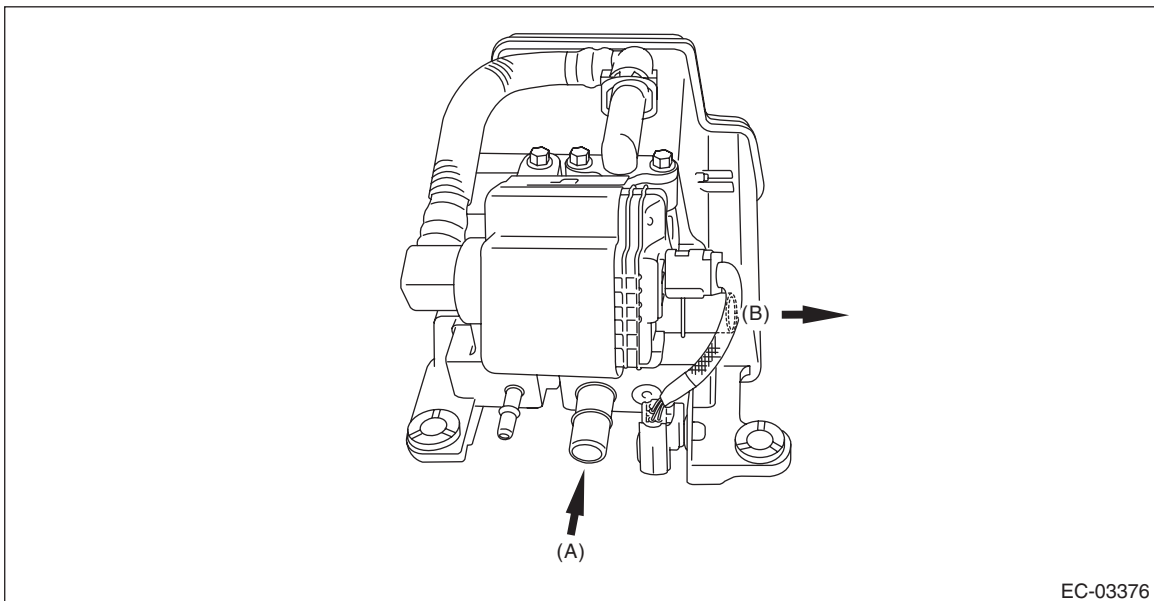

# Leak Check Valve Assembly

EMISSION CONTROL (AUX. EMISSION CONTROL DEVICES)

3) Connect the battery positive terminal to the terminal No. 5 and the battery negative terminal to the terminal No. 1. Check that air does not come out from (B) when air is blown into (A).

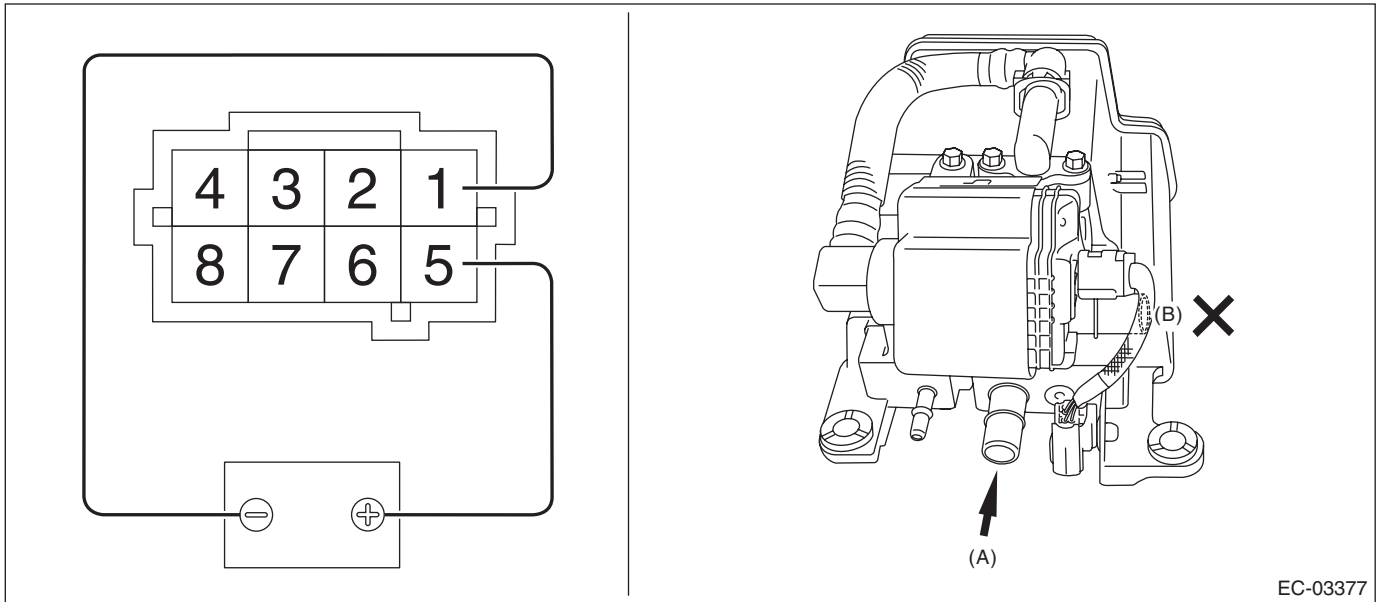

## 2. CHECK VACUUM PUMP

1) Connect the battery positive terminal to terminal No. 3 and the battery ground terminal to terminal No. 4, and inspect the vacuum pump operation.

### CAUTION:

Do not operate the vacuum pump for 5 minutes or more.

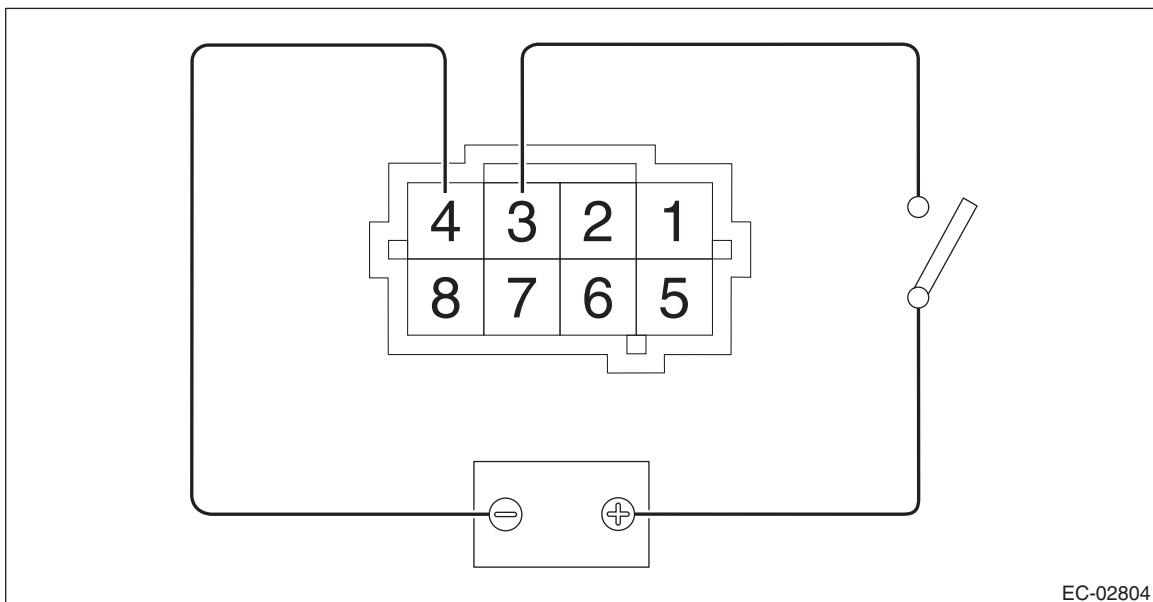

# Leak Check Valve Assembly

EMISSION CONTROL (AUX. EMISSION CONTROL DEVICES)

## 3. CHECK PRESSURE SENSOR

1) Connect dry-cell battery positive terminal to terminal No. 6 and dry-cell battery ground terminal to terminal No. 8, circuit tester positive terminal to terminal No. 7 and the circuit tester negative terminal to terminal No. 8.

NOTE:

- Use new dry-cell batteries.
- Using circuit tester, check the voltage of a single dry-cell battery is 1.6 V or more. And also check the voltage of three batteries in series is between 4.8 V and 5.2 V.

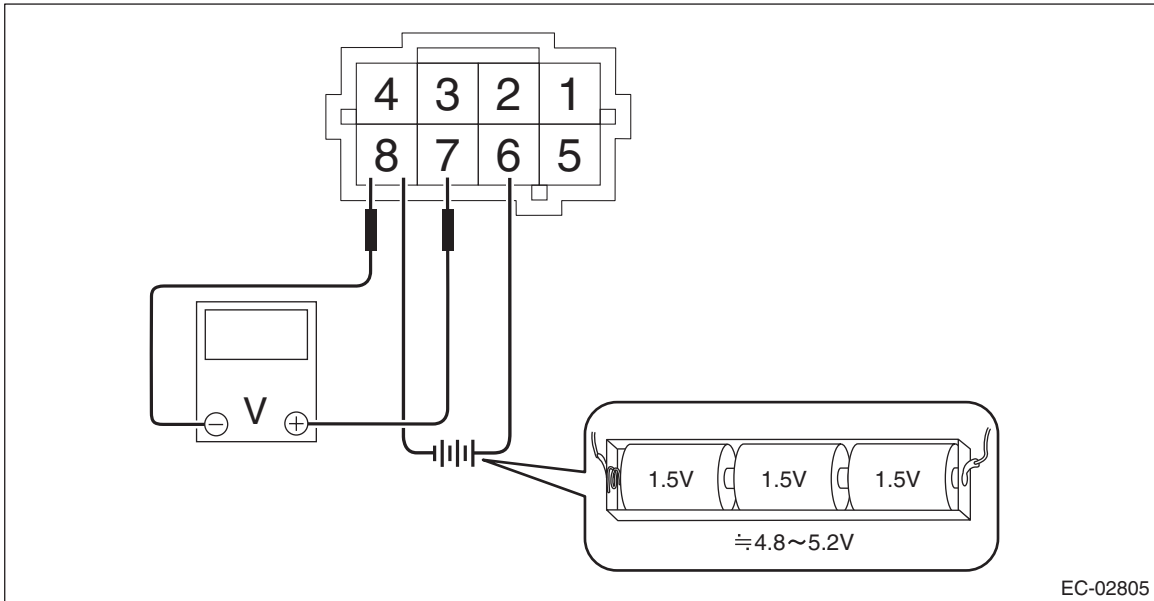

2) Check the voltage at a normal atmospheric pressure.

NOTE:

The atmospheric pressure at higher altitude is lower than normal. Therefore, the voltage is lower than the standard value.

Terminal No.	Standard
7 (+) and 8 (-)	Approx. 3.5 V (when 25°C (77°F))

3) Connect the battery positive terminal to terminal No. 3 and the battery ground terminal to terminal No. 4, and check that there is a voltage drop from the voltage measured in step 2) when the vacuum pump is operated.

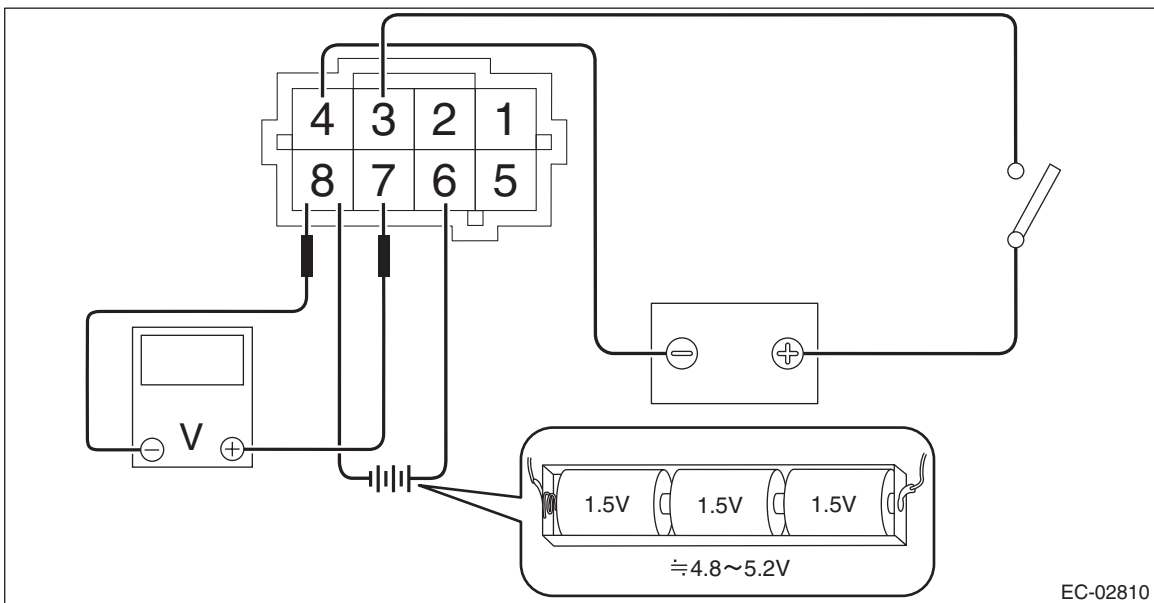

# **Leak Check Valve Assembly**

EMISSION CONTROL (AUX. EMISSION CONTROL DEVICES)

---

## **4. OTHER INSPECTIONS**

Check that the leak check valve assembly has no deformation, cracks or other damages.