

12. Drive Cycle

A: PROCEDURE

It is necessary to perform the drive cycle listed below if DTC is not found in the Inspection Mode. It is possible to complete diagnosis of the DTC by performing the indicated drive cycle. After the repair for the DTC, perform a necessary drive cycle and make sure the function recovers and the DTC is recorded.

1. PREPARATION FOR DRIVE CYCLE

- 1) Check that the battery voltage is 12 V or more and fuel remains approx. half [20 — 40 L (5.3 — 10.6 US gal, 4.4 — 8.8 Imp gal)].
- 2) After performing the diagnostics and Clear Memory Mode, check that no DTC remains. <Ref. to EN(H4DO)(diag)-59, Clear Memory Mode.>

NOTE:

Perform the drive cycle after warming up the engine except when the engine coolant temperature at engine start is specified.

2. DRIVE CYCLE A

DTC	Item	Condition
P0125	Insufficient Coolant Temperature for Closed Loop Fuel Control	«Coolant Temp.» at engine start: Less than 15°C (5°F)
P0128	Coolant Thermostat (Engine Coolant Temperature Below Thermostat Regulating Temperature)	—
P0141	O2 Sensor Heater Circuit (Bank1 Sensor2)	—
P014C	O2 Sensor Slow Response - Rich to Lean (Bank 1 Sensor 1)	—
P014D	O2 Sensor Slow Response - Lean to Rich (Bank 1 Sensor 1)	—
P015A	O2 Sensor Delayed Response - Rich to Lean (Bank 1 Sensor 1)	—
P015B	O2 Sensor Delayed Response - Lean to Rich (Bank 1 Sensor 1)	—
P0171	System Too Lean (Bank 1)	Complete diagnosis with drive cycle B or C as well.
P0172	System Too Rich (Bank 1)	Complete diagnosis with drive cycle B or C as well.
P0196	Engine Oil Temperature Sensor Circuit Range/Performance	—
P0300	Random/Multiple Cylinder Misfire Detected	Complete diagnosis with drive cycle B or C as well.
P0301	Cylinder 1 Misfire Detected	Complete diagnosis with drive cycle B or C as well.
P0302	Cylinder 2 Misfire Detected	Complete diagnosis with drive cycle B or C as well.
P0303	Cylinder 3 Misfire Detected	Complete diagnosis with drive cycle B or C as well.
P0304	Cylinder 4 Misfire Detected	Complete diagnosis with drive cycle B or C as well.
P0420	Catalyst System Efficiency Below Threshold (Bank 1)	—
P0459	Evaporative Emission System Purge Control Valve Circuit High	—
P2096	Post Catalyst Fuel Trim System Too Lean (Bank 1)	Complete diagnosis with drive cycle B or C as well.
P2097	Post Catalyst Fuel Trim System Too Rich (Bank 1)	Complete diagnosis with drive cycle B or C as well.
P2195	O2 Sensor Signal Biased/Stuck Lean (Bank 1 Sensor 1)	—
P2196	O2 Sensor Signal Biased/Stuck Rich (Bank 1 Sensor 1)	—

Diagnostic procedure:

- 1) Drive for 20 minutes or more at a constant speed of 80 km/h (50 MPH) or more.
- 2) Stop the vehicle and idle for one minute.
- 3) Read the temporary code using the Subaru Select Monitor or general scan tool. <Ref. to EN(H4DO)(diag)-45, OPERATION, Read Diagnostic Trouble Code (DTC).>

Drive Cycle

ENGINE (DIAGNOSTICS)

3. DRIVE CYCLE B

DTC	Item	Condition
P0010	"A" Camshaft Position Actuator Circuit/Open (Bank 1)	—
P0016	Crankshaft Position - Camshaft Position Correlation (Bank1)	—
P0018	Crankshaft Position - Camshaft Position Correlation (Bank2)	—
P0020	"A" Camshaft Position Actuator Circuit/Open (Bank 2)	—
P0137	O2 Sensor Circuit Low Voltage (Bank 1 Sensor 2)	—
P0138	O2 Sensor Circuit High Voltage (Bank 1 Sensor 2)	—
P0171	System Too Lean (Bank 1)	Complete diagnosis with drive cycle A or C as well.
P0172	System Too Rich (Bank 1)	Complete diagnosis with drive cycle A or C as well.
P0201	Injector #1	—
P0202	Injector #2	—
P0203	Injector #3	—
P0204	Injector #4	—
P0300	Random/Multiple Cylinder Misfire Detected	Complete diagnosis with drive cycle A or C as well.
P0301	Cylinder 1 Misfire Detected	Complete diagnosis with drive cycle A or C as well.
P0302	Cylinder 2 Misfire Detected	Complete diagnosis with drive cycle A or C as well.
P0303	Cylinder 3 Misfire Detected	Complete diagnosis with drive cycle A or C as well.
P0304	Cylinder 4 Misfire Detected	Complete diagnosis with drive cycle A or C as well.
P0351	Ignition Coil A Primary/Secondary Circuit	—
P0352	Ignition Coil B Primary/Secondary Circuit	—
P0353	Ignition Coil C Primary/Secondary Circuit	—
P0354	Ignition Coil D Primary/Secondary Circuit	—
P0500	Vehicle Speed Sensor "A"	—
P0506	Idle Air Control System RPM Lower Than Expected	—
P0507	Idle Air Control System RPM Higher Than Expected	—
P0700	Transmission Control System (MIL Request)	—
P2006	Intake Manifold Runner Control Stuck Closed (Bank 1)	—
P2007	Intake Manifold Runner Control Stuck Closed (Bank 2)	—
P2009	Intake Manifold Runner Control Circuit Low (Bank 1)	—
P2012	Intake Manifold Runner Control Circuit Low (Bank 2)	—
P2096	Post Catalyst Fuel Trim System Too Lean (Bank 1)	Complete diagnosis with drive cycle A or C as well.
P2097	Post Catalyst Fuel Trim System Too Rich (Bank 1)	Complete diagnosis with drive cycle A or C as well.
P2135	Throttle/Pedal Position Sensor/Switch "A"/"B" Voltage Correlation	—
P2138	Throttle/Pedal Position Sensor/Switch "D"/"E" Voltage Correlation	—
P219A	Bank 1 Air-Fuel Ratio Imbalance	Complete diagnosis with drive cycle C as well.

Diagnostic procedure:

- 1) Drive at 10 km/h (6 MPH) or more.
- 2) Stop the vehicle and idle for ten minutes.
- 3) Read the temporary code using the Subaru Select Monitor or general scan tool. <Ref. to EN(H4DO)(diag)-45, OPERATION, Read Diagnostic Trouble Code (DTC).>

Drive Cycle

ENGINE (DIAGNOSTICS)

4. DRIVE CYCLE C

DTC	Item	Condition
P000A	A Camshaft Position Slow Response (Bank 1)	—
P000C	A Camshaft Position Slow Response (Bank 2)	—
P0011	Intake Camshaft Position - Timing Over-Advanced or System Performance (Bank 1)	—
P0021	Intake Camshaft Position - Timing Over-Advanced or System Performance (Bank 2)	—
P0030	HO2S Heater Control Circuit (Bank 1 Sensor 1)	—
P0068	MAP/MAF - Throttle Position Correlation	—
P0101	Mass or Volume Air Flow Circuit Range/Performance	—
P0134	O2 Sensor Circuit No Activity Detected (Bank 1 Sensor 1)	—
P013A	O2 Sensor Slow Response - Rich to Lean (Bank 1 Sensor 2)	—
P013B	O2 Sensor Slow Response - Lean to Rich (Bank 1 Sensor 2)	—
P013E	O2 Sensor Delayed Response - Rich to Lean (Bank 1 Sensor 2)	—
P013F	O2 Sensor Delayed Response - Lean to Rich (Bank 1 Sensor 2)	—
P0140	O2 Sensor Circuit No Activity Detected (Bank1 Sensor2)	—
P0171	System Too Lean (Bank 1)	Complete diagnosis with drive cycle A or B as well.
P0172	System Too Rich (Bank 1)	Complete diagnosis with drive cycle A or B as well.
P0300	Random/Multiple Cylinder Misfire Detected	Complete diagnosis with drive cycle A or B as well.
P0301	Cylinder 1 Misfire Detected	Complete diagnosis with drive cycle A or B as well.
P0302	Cylinder 2 Misfire Detected	Complete diagnosis with drive cycle A or B as well.
P0303	Cylinder 3 Misfire Detected	Complete diagnosis with drive cycle A or B as well.
P0304	Cylinder 4 Misfire Detected	Complete diagnosis with drive cycle A or B as well.
P0400	Exhaust Gas Recirculation Flow	—
P0441	Evaporative Emission Cont. Sys. Incorrect Purge Flow	—
P0851	Park/Neutral Switch Input Circuit Low	—
P0852	Park/Neutral Switch Input Circuit High	—
P1449	Evaporative Emission Cont. Sys. Air Filter Clog	—
P1492	EGR Solenoid Valve Signal #1 Circuit Malfunction (Low Input)	—
P1493	EGR Solenoid Valve Signal #1 Circuit Malfunction (High Input)	—
P1494	EGR Solenoid Valve Signal #2 Circuit Malfunction (Low Input)	—
P1495	EGR Solenoid Valve Signal #2 Circuit Malfunction (High Input)	—
P1496	EGR Solenoid Valve Signal #3 Circuit Malfunction (Low Input)	—
P1497	EGR Solenoid Valve Signal #3 Circuit Malfunction (High Input)	—
P1498	EGR Solenoid Valve Signal #4 Circuit Malfunction (Low Input)	—
P1499	EGR Solenoid Valve Signal #4 Circuit Malfunction (High Input)	—
P2004	Intake Manifold Runner Control Stuck Open (Bank 1)	—
P2005	Intake Manifold Runner Control Stuck Open (Bank 2)	—
P2096	Post Catalyst Fuel Trim System Too Lean (Bank 1)	Complete diagnosis with drive cycle A or B as well.
P2097	Post Catalyst Fuel Trim System Too Rich (Bank 1)	Complete diagnosis with drive cycle A or B as well.
P219A	Bank 1 Air-Fuel Ratio Imbalance	Complete diagnosis with drive cycle B as well.

Drive Cycle

ENGINE (DIAGNOSTICS)

Diagnostic procedure:

1) Drive according to the drive pattern described below.

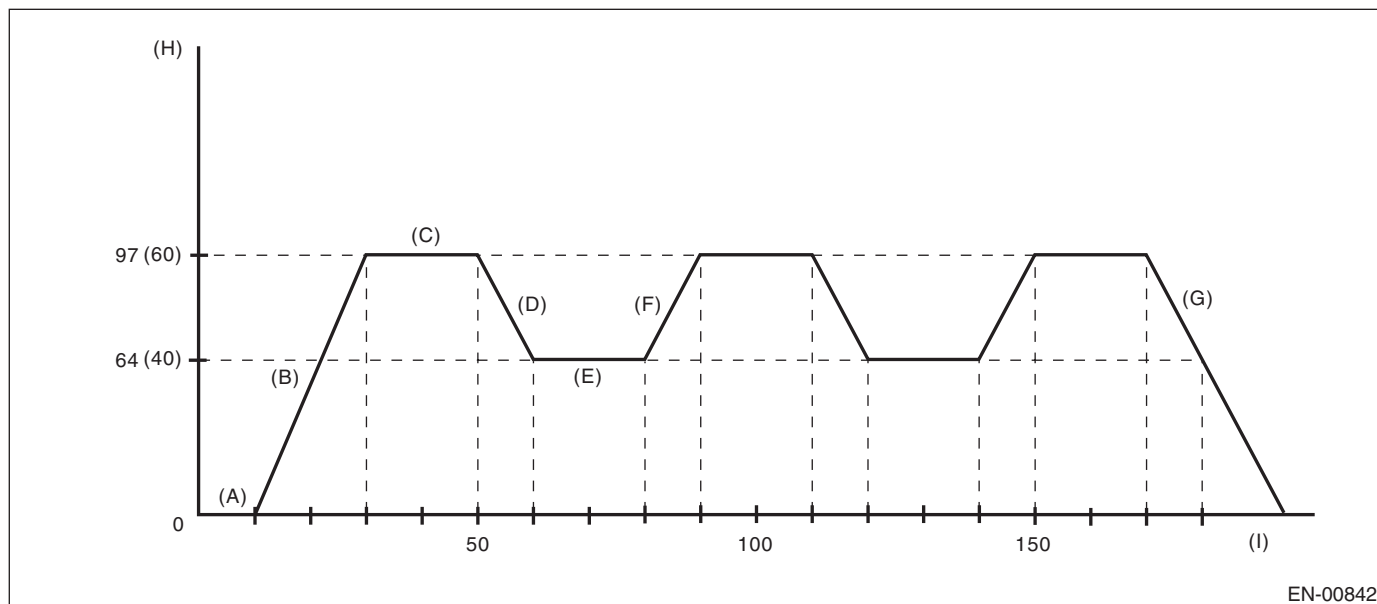

(A) Shift the select lever to “P” range or the shift lever to the neutral position, and let the engine idle for 10 seconds or more.

(B) Accelerate to 97 km/h (60 MPH) or more within 20 seconds.

(C) Drive for 20 seconds or more at 97 km/h (60 MPH) or more.

(D) Decelerate with fully closed throttle to 64 km/h (40 MPH) or less.

(E) Drive for 20 seconds or more at 64 km/h (40 MPH) or less.

(F) Accelerate to 97 km/h (60 MPH) or more within 10 seconds.

(G) Stop vehicle with the throttle fully closed.

(H) Vehicle speed km/h (MPH)

(I) Sec.

2) Read the temporary code using the Subaru Select Monitor or general scan tool. <Ref. to EN(H4DO)(diag)-45, OPERATION, Read Diagnostic Trouble Code (DTC).>

5. DRIVE CYCLE E

DTC	Item	Condition
P0461	Fuel Level Sensor “A” Circuit Range/Performance	—

Diagnostic procedure:

1) Make sure that the battery voltage is 10.9 V or more.

2) Perform the Clear Memory Mode. <Ref. to EN(H4DO)(diag)-59, Clear Memory Mode.>

3) Drive for approximately 30 L (7.9 US gal, 6.6 Imp gal) of fuel.

NOTE:

- It is acceptable to drive the vehicle intermittently.
- Do not disconnect the battery terminals while diagnosing. (Data will be cleared by disconnecting the battery terminals.)

4) Read the temporary code using the Subaru Select Monitor or general scan tool. <Ref. to EN(H4DO)(diag)-45, OPERATION, Read Diagnostic Trouble Code (DTC).>

6. DRIVE CYCLE F

DTC	Item	Condition
P0111	Intake Air Temperature Sensor Range/Performance Problem	—

Diagnostic procedure:

- 1) Make sure that the engine coolant temperature is less than 30°C (86°F).
- 2) Drive according to the drive pattern described below.

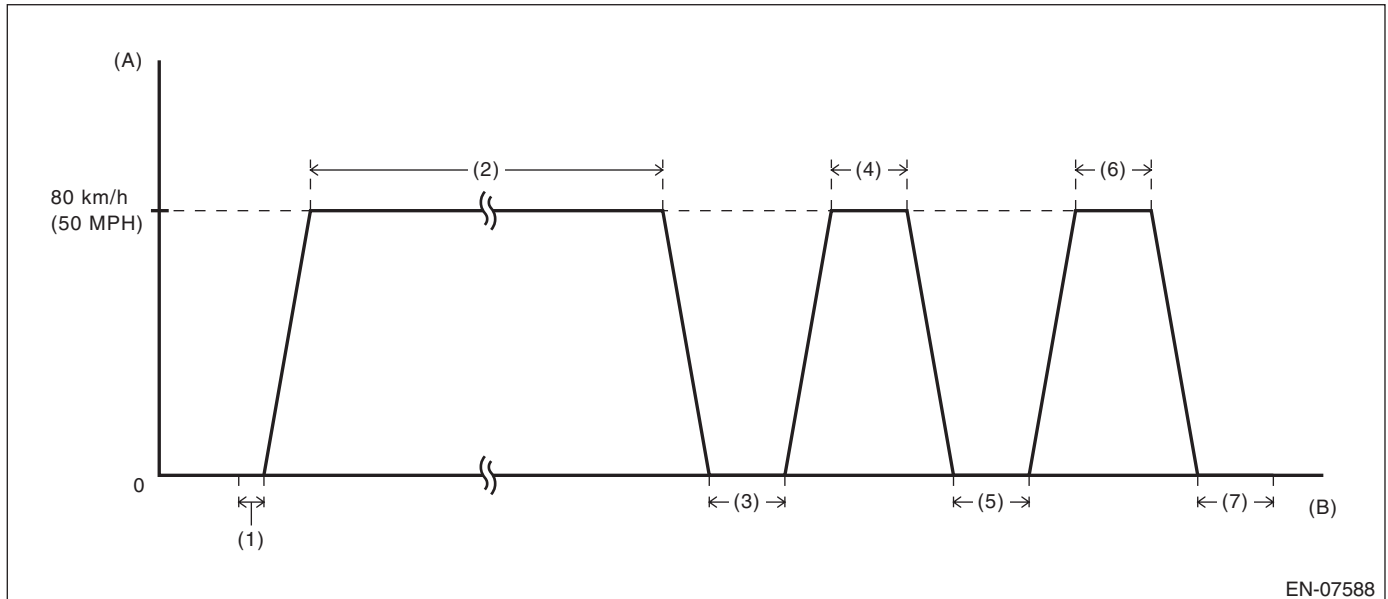

EN-07588

(A) Vehicle speed

(B) Elapsed time

- | | | |
|--|---|---|
| <p>(1) Idle the engine for 10 seconds or more after engine start.</p> <p>(2) Drive for 8 minutes or more at a constant speed of 80 km/h (50 MPH) or more.</p> <p>(3) Stop the vehicle and idle for 30 seconds or more.</p> | <p>(4) Drive for 30 seconds or more at a constant speed of 80 km/h (50 MPH) or more.</p> <p>(5) Stop the vehicle and idle for 30 seconds or more.</p> | <p>(6) Drive for 30 seconds or more at a constant speed of 80 km/h (50 MPH) or more.</p> <p>(7) Stop the vehicle and idle for 30 seconds.</p> |
|--|---|---|

NOTE:

- There is no given transition time between idling and cruising.
 - Driving at constant speed only on a downhill causes smaller engine load and may result in failure to obtain a right diagnostic result.
 - When the engine stops while performing drive cycle F, perform it again from the state of procedure 1).
- 3) Read the temporary code using the Subaru Select Monitor or general scan tool. <Ref. to EN(H4DO)(diag)-45, OPERATION, Read Diagnostic Trouble Code (DTC).>

Drive Cycle

ENGINE (DIAGNOSTICS)

7. DRIVE CYCLE H

DTC	Item	Condition
P0116	Engine Coolant Temperature Sensor 1 Circuit Range/Performance	6 hours have elapsed since ignition switch is OFF under a completely warmed up condition.
P0451	Evaporative Emission System Pressure Sensor/Switch Range/Performance	60 seconds have elapsed since ignition switch is OFF.
P050A	Cold Start Idle Air Control System Performance	—
P050B	Cold Start Ignition Timing Performance	—

Diagnostic procedure:

- 1) Perform the Clear Memory Mode. <Ref. to EN(H4DO)(diag)-59, Clear Memory Mode.>
- 2) With the ignition switch ON (engine stopped), read the values in «Coolant Temp.» and «Intake Air Temp.» <Ref. to EN(H4DO)(diag)-38, DISPLAY CURRENT ENGINE DATA, OPERATION, Subaru Select Monitor.>
- 3) If the values from step 2) satisfy the following conditions, idle the engine for one minute.

Condition:

$$|\text{Engine coolant temperature} - \text{Intake air temperature}| \leq 5^{\circ}\text{C} (9^{\circ}\text{F})$$

NOTE:

- If the conditions are not satisfied, turn the ignition switch to OFF and wait until the parameters are satisfied.
 - For CVT models, hold the select lever to “P” range or “N” range at idling, and for MT models, the shift lever in the neutral position at idling.
- 4) Read the temporary code using the Subaru Select Monitor or general scan tool. <Ref. to EN(H4DO)(diag)-45, OPERATION, Read Diagnostic Trouble Code (DTC).>

8. DRIVE CYCLE I

DTC	Item	Condition
P0455	Evaporative Emission System Leak Detected (Large Leak)	«Coolant Temp.»: 5 — 45°C (41 — 113°F) «Intake Air Temp.»: 5 — 50°C (41 — 122°F)
P0456	Evaporative Emission Control System Leak Detected (Very Small Leak)	
P1451	Evaporative Emission Cont. Sys.	
P2402	Evaporative Emission System Leak Detection Pump Control Circuit High	
P2404	Evaporative Emission System Leak Detection Pump Sense Circuit Range/Performance	
P2420	Evaporative Emission System Switching Valve Control Circuit High	

CAUTION:

Be careful of the state of the battery when performing the drive cycle I consecutively. Performing the drive cycle I consecutively without the engine running may cause a low battery voltage and battery discharge.

NOTE:

- If it is necessary to perform drive cycle I consecutively, drive the vehicle under the following conditions to release accumulated evaporating gas. Performing the drive cycle I consecutively without starting the engine causes a large amount of evaporating gas to accumulate in the canister, which hinders an accurate diagnosis.
 - After engine is warmed up.
 - Drive for 10 minutes or more at a speed of 48 km/h (30 MPH) or more (duration of drive can be an accumulation)

- To obtain an accurate diagnostic result, perform the procedures according to the following points.
 - Do not refuel gas immediately before performing drive cycle I. There will be a large amount of evaporating gas immediately after refuel, which may cause a less accurate diagnostic performance.
 - Do not shake the vehicle while performing drive cycle I. Shaking the vehicle causes evaporating gas to increase inside the fuel tank, which may cause a less accurate diagnostic performance.
 - Do not perform any service operation including installation or removal of parts or connectors while performing drive cycle I. Performing service operation could affect on the functions of related parts, which may cause a less accurate diagnostic performance.
- Perform MODE \$08 when using a general scan tool.

Diagnostic procedure:

1) Prepare the Subaru Select Monitor kit. <Ref. to EN(H4DO)(diag)-8, PREPARATION TOOL, General Description.>

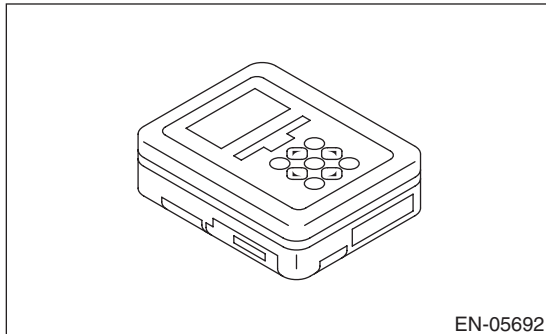

2) Prepare PC with Subaru Select Monitor installed.

3) Connect the USB cable to SDI (Subaru Diagnosis Interface) and USB port on the personal computer (dedicated port for the Subaru Select Monitor).

NOTE:

The dedicated port for the Subaru Select Monitor means the USB port which was used to install the Subaru Select Monitor.

4) Connect the diagnosis cable to SDI.

5) Connect SDI to data link connector located in the lower portion of the instrument panel (on the driver's side).

CAUTION:

Do not connect the scan tools except for Subaru Select Monitor and general scan tool.

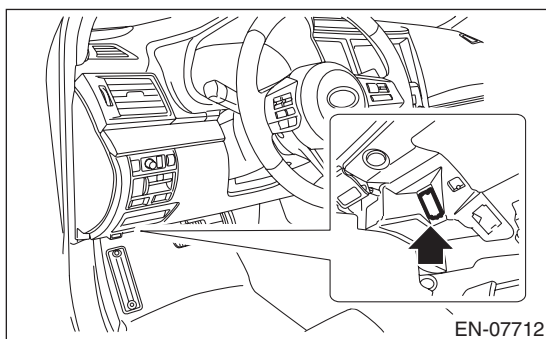

6) Start the PC.

7) Turn the ignition switch to ON (engine OFF) and run the "PC application for Subaru Select Monitor".

8) On «Main Menu» display, select {Each System Check}.

9) On «System Selection Menu» display, select {Engine Control System}.

10) Click the [OK] button after the information of engine type has been displayed.

11) On «Engine Diagnosis» display, select {OBD System}.

12) On «OBD Menu» display, select {Evaporative System Leak Test}.

13) On «Evaporative System Leak Test» display, select {Evaporative System Leak Test}.

14) On «Evaporative System Leak Test is running. Press Cancel to exit this function.» display, click the [OK] button to perform evaporative system leak test.

Drive Cycle

ENGINE (DIAGNOSTICS)

15) When «Conditions have been enabled to control this function. Turn the ignition switch off to terminate the test.» display appears, wait for 30 minutes without clicking the [OK] button.

CAUTION:

Do not leave the vehicle for an extended period of time after the test is complete. This may cause early deterioration of the battery or discharged battery.

NOTE:

- Clicking the [OK] button bring the «Evaporative System Leak Test» display back, although the test is continuing.
- The Subaru Select Monitor screen does not change after the evaporative system leak test is complete or when the test is aborted by turning off the ignition switch.
- If «Test conditions are not correct» display appears, use Subaru Select Monitor to check that the values in «Coolant Temp.» and «Intake Air Temp.» are within the specified range. If the conditions are satisfied, make the necessary preparation for the drive cycle again. <Ref. to EN(H4DO)(diag)-49, PREPARATION FOR DRIVE CYCLE, PROCEDURE, Drive Cycle.>

16) After 30 minutes passed from the start of step 14), click the [OK] button to return to the «Evaporative System Leak Test» display.

17) Click buttons until the «OBd Menu» display appears, then select {Result of on-board monitor test}.

18) In the {Result of on-board monitor test}, check TID \$C1 — \$CA of MID \$3C.

NOTE:

Perform MODE \$06 and check when using a general scan tool.

Result of on-board monitor test

Display	Details	Remarks
\$0000 is stored in all Val.	During the evaporative system leak test, the test conditions were not met and the test was canceled.	Once the test conditions are met, perform the test again.
All Val. are stored with values and OK is set to all the results.	Evaporative system leak test is completed correctly.	While the ignition switch is ON, read the pending code using the Subaru Select Monitor.
Some results were no good.	The evaporative system leak test completed successfully but the results were faulty.	While the ignition switch is ON, read the pending code using the Subaru Select Monitor.

19) When the evaporative system leak test is completed correctly, read the pending code with the ignition switch turned to ON position. If the DTC is recorded, check the appropriate DTC. <Ref. to EN(H4DO)(diag)-45, OPERATION, Read Diagnostic Trouble Code (DTC).>

NOTE:

- Perform MODE \$07 when using a general scan tool.
- The pending code will be cleared by turning ignition switch to OFF.

9. DRIVE CYCLE J

DTC	Item	Condition
P2610	ECM/PCM Internal Engine Off Timer Performance	—

Diagnostic procedure:

- 1) Idle the engine for 15 minutes or more.
- 2) Turn the ignition switch to OFF.
- 3) After 10 hours passed from the start of step 2), read the temporary code using the Subaru Select Monitor or general scan tool. <Ref. to EN(H4DO)(diag)-45, OPERATION, Read Diagnostic Trouble Code (DTC).>

10.DRIVE CYCLE K

DTC	Item	Condition
P0458	Evaporative Emission System Purge Control Valve Circuit Low	—
P2401	Evaporative Emission System Leak Detection Pump Control Circuit Low	«Coolant Temp.»: 5 — 45°C (41 — 113°F) «Intake Air Temp.»: 5 — 50°C (41 — 122°F)
P2419	Evaporative Emission System Switching Valve Control Circuit Low	

Diagnostic procedure:

1) Lift up the vehicle using a garage jack and place it on rigid racks, or drive the vehicle onto free rollers.

WARNING:

- Before lifting up the vehicle, ensure parking brake is applied.
- Do not use a pantograph jack in place of a rigid rack.
- Secure a rope or wire to the front or rear towing hooks to prevent the lateral runout of front wheels.
- Before rotating the wheels, make sure that there is no one in front of the vehicle. Besides while the wheels are rotating, make sure that no one approaches the vehicle front side.
- Make sure that there is nothing around the wheels. For AWD model, pay attention to all four wheels.
- While servicing, do not depress or release the clutch pedal or accelerator pedal quickly regardless of the engine speed. Quick operation may cause the vehicle to drop off the free roller.
- To prevent the vehicle from slipping due to vibration, do not place anything between rigid rack and the vehicle.

NOTE:

On vehicles equipped with EyeSight, turn the pre-collision function to OFF.

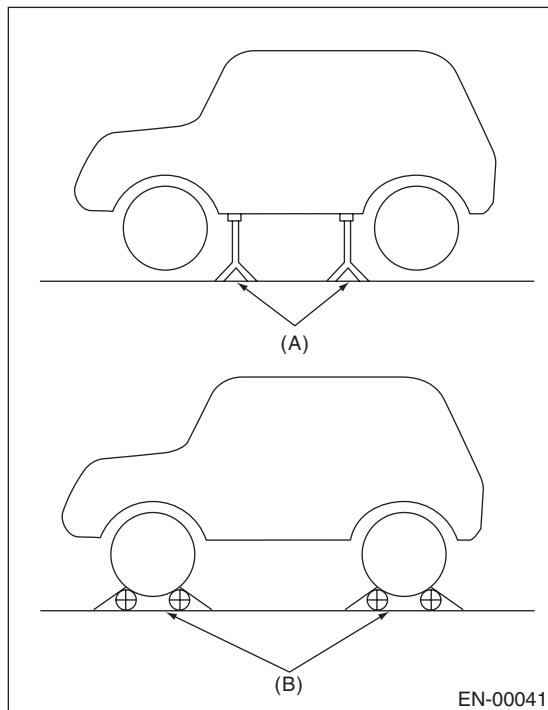

- (A) Rigid rack
- (B) Free roller

Drive Cycle

ENGINE (DIAGNOSTICS)

2) Connect the Subaru Select Monitor or general scan tool to data link connector located in the lower portion of the instrument panel (on the driver's side).

CAUTION:

Do not connect the scan tools except for Subaru Select Monitor and general scan tool.

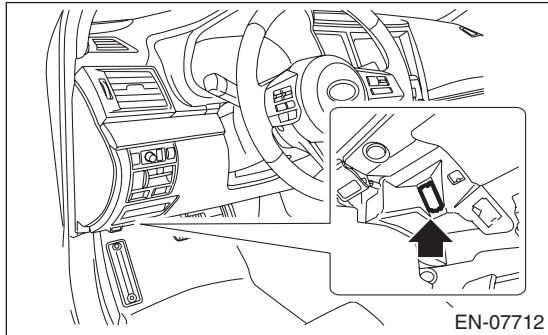

3) Start the engine.

NOTE:

Ensure the selector lever is placed in the "P" range before starting.

4) Turn the neutral position switch to ON using select lever.

5) Depress the brake pedal to turn the brake switch ON.

6) Keep the engine speed in 2,500 — 3,000 rpm range for 40 seconds.

7) Shift the select lever in the "D" range and drive the vehicle at 5 to 10 km/h (3 to 6 MPH).

NOTE:

- For AWD model, release the parking brake.
- The rotating speed difference between front and rear wheels may illuminate the ABS warning light, but this does not indicate a malfunction. When engine control system diagnosis is finished, perform the VDC memory clearance procedure of self-diagnosis function. <Ref. to VDC(diag)-25, Clear Memory Mode.>

8) Read the temporary code using the Subaru Select Monitor or general scan tool. <Ref. to EN(H4DO)(diag)-45, OPERATION, Read Diagnostic Trouble Code (DTC).>