

16. Diagnostics for Engine Starting Failure

A: PROCEDURE

1. Check of the fuel amount
↓
2. Inspection of starter motor circuit <Ref. to EN(H4DO)(diag)-64, STARTER MOTOR CIRCUIT, Diagnostics for Engine Starting Failure.>
↓
3. Inspection of ECM power supply and ground line <Ref. to EN(H4DO)(diag)-74, CHECK POWER SUPPLY AND GROUND LINE OF ENGINE CONTROL MODULE (ECM), Diagnostics for Engine Starting Failure.>
↓
4. Inspection of ignition control system <Ref. to EN(H4DO)(diag)-77, IGNITION CONTROL SYSTEM, Diagnostics for Engine Starting Failure.>
↓
5. Inspection of fuel pump circuit <Ref. to EN(H4DO)(diag)-79, FUEL PUMP CIRCUIT, Diagnostics for Engine Starting Failure.>
↓
6. Inspection of fuel injector circuit <Ref. to EN(H4DO)(diag)-82, FUEL INJECTOR CIRCUIT, Diagnostics for Engine Starting Failure.>

Diagnostics for Engine Starting Failure

ENGINE (DIAGNOSTICS)

B: STARTER MOTOR CIRCUIT

1. MODEL WITHOUT PUSH BUTTON START

CAUTION:

After servicing or replacing faulty parts, perform Clear Memory Mode <Ref. to EN(H4DO)(diag)-59, Clear Memory Mode.>, and Inspection Mode <Ref. to EN(H4DO)(diag)-46, Inspection Mode.>.

WIRING DIAGRAM:

Engine electrical system, 2.5 L model (without push button start)<Ref. to WI-122, 2.5 L MODEL (WITHOUT PUSH BUTTON START), WIRING DIAGRAM, Engine Electrical System.>

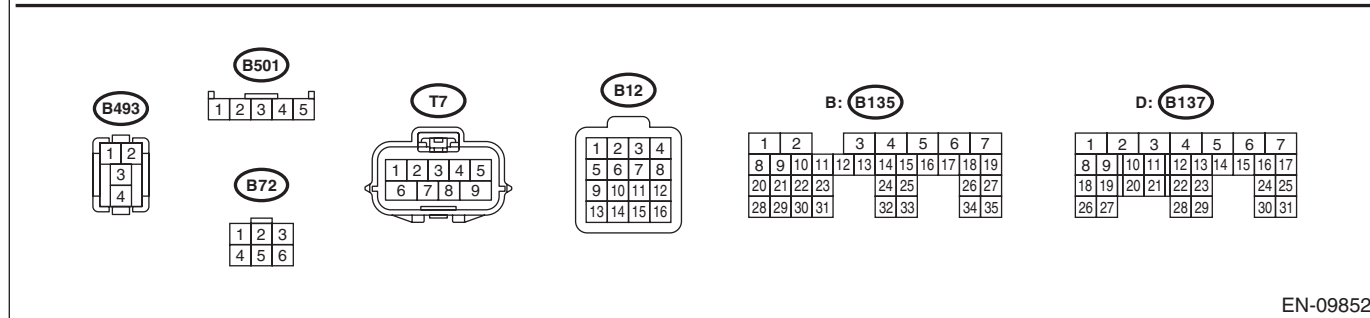
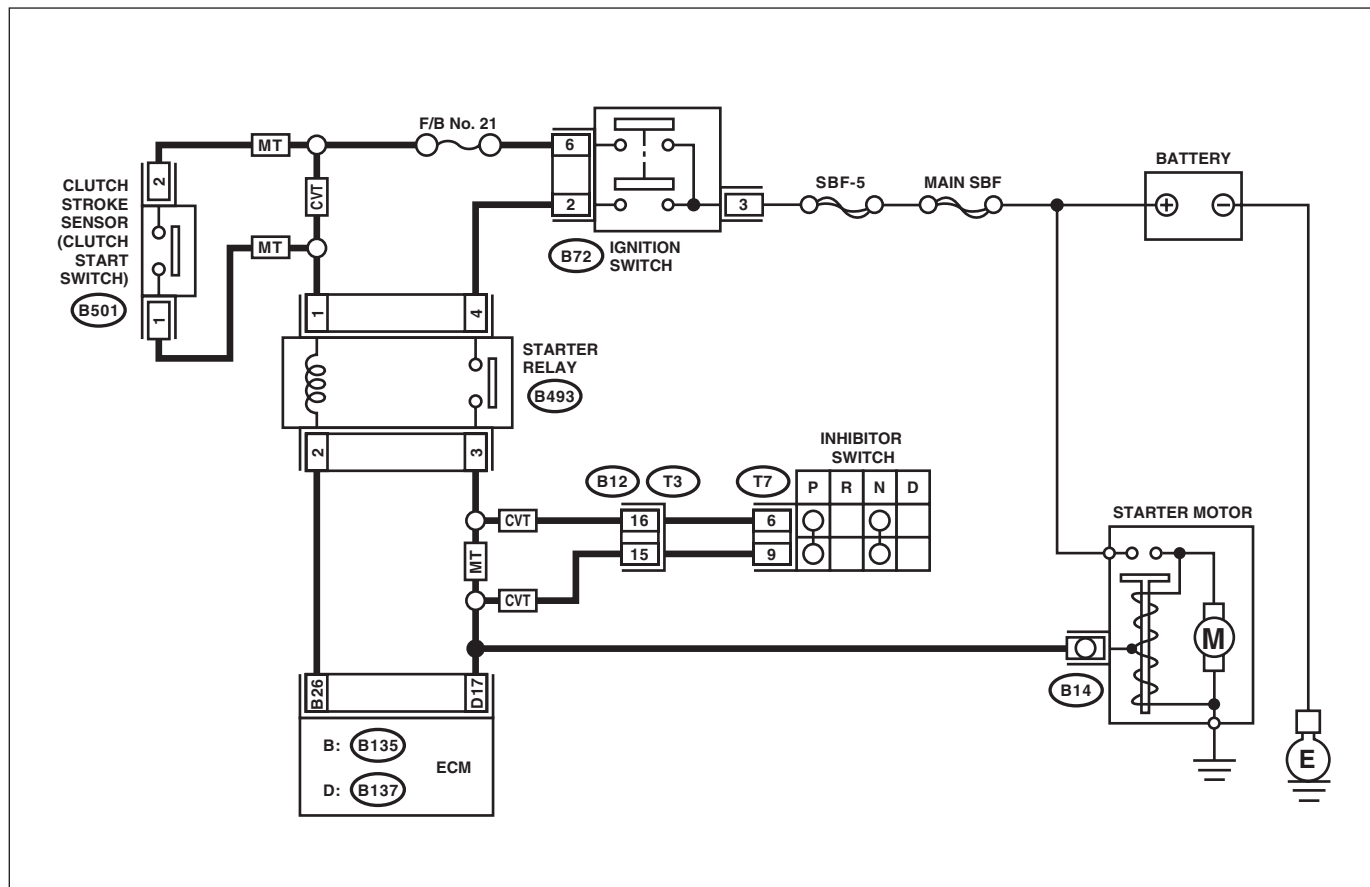

EN-09852

Step	Check	Yes	No
1	CHECK BATTERY. Check the battery. <Ref. to SC(H4DO)-51, Battery.>	Go to step 2.	Charge or replace the battery. <Ref. to SC(H4DO)-51, Battery.>
2	CHECK OPERATION OF STARTER MOTOR. Does the starter motor operate?	Go to step 3.	Go to step 4.

Diagnostics for Engine Starting Failure

ENGINE (DIAGNOSTICS)

Step	Check	Yes	No
3 CHECK DTC.	Is DTC displayed? <Ref. to EN(H4DO)(diag)-45, OPERATION, Read Diagnostic Trouble Code (DTC).>	Check the appropriate DTC using the "List of Diagnostic Trouble Code (DTC)". <Ref. to EN(H4DO)(diag)-84, List of Diagnostic Trouble Code (DTC).>	Check ignition control system. <Ref. to EN(H4DO)(diag)-77, IGNITION CONTROL SYSTEM, Diagnostics for Engine Starting Failure.>
4 CHECK INPUT SIGNAL FOR STARTER MOTOR. 1) Turn the ignition switch to OFF. 2) Disconnect the connector from starter motor. 3) Turn the ignition switch to START. 4) Measure the voltage between the starter motor connector and the engine ground. Connector & terminal (B14) No. 1 (+) — Engine ground (-): NOTE: • For CVT model, place the select lever in "P" range or "N" range. • For MT model, depress the clutch pedal.	Is the voltage 10 V or more?	Check the starter motor. <Ref. to SC(H4DO)-7, Starter.>	Go to step 5.
5 CHECK HARNESS BETWEEN BATTERY AND IGNITION SWITCH CONNECTOR. 1) Turn the ignition switch to OFF. 2) Disconnect the connector from ignition switch. 3) Measure the power supply voltage between ignition switch connector and chassis ground. Connector & terminal (B72) No. 3 (+) — Chassis ground (-):	Is the voltage 10 V or more?	Go to step 6.	Repair the power supply circuit.
6 CHECK IGNITION SWITCH. Measure the resistance between ignition switch terminals after turning the ignition switch to START position. Terminals No. 3 — No. 2: No. 3 — No. 6:	Is the resistance less than 1 Ω?	Go to step 7.	Replace the ignition switch. <Ref. to SL-67, REPLACEMENT, Ignition Key Lock.>
7 CHECK INPUT VOLTAGE OF STARTER RELAY. 1) Turn the ignition switch to OFF. 2) Remove the starter relay. 3) Connect the connector to ignition switch. 4) Measure the voltage between starter relay connector and chassis ground after turning the ignition switch to START position. Connector & terminal (B493) No. 1 (+) — Chassis ground (-): (B493) No. 4 (+) — Chassis ground (-): NOTE: For MT model, depress the clutch pedal.	Is the voltage 10 V or more?	Go to step 8.	Check the following item and repair if necessary. • Blown out of fuse • Open or short circuit to ground in harness between starter relay and ignition switch connector • Poor contact of the clutch start switch connector (MT model) • Clutch start switch trouble (MT model)

Diagnostics for Engine Starting Failure

ENGINE (DIAGNOSTICS)

Step	Check	Yes	No
8 CHECK STARTER RELAY. 1) Connect the battery to starter relay terminals No. 1 and No. 2. 2) Measure the resistance between starter relay terminals. <i>Terminals</i> <i>No. 3 — No. 4:</i>	Is the resistance less than 1 Ω ?	Go to step 9.	Replace the starter relay. <Ref. to EN(H4DO)(diag)-9, Electrical Component Location.>
9 CHECK HARNESS BETWEEN ECM AND STARTER RELAY CONNECTOR. 1) Turn the ignition switch to OFF. 2) Disconnect the connector from ECM. 3) Measure the resistance of harness between ECM connector and starter relay connector. <i>Connector & terminal</i> <i>(B135) No. 26 — (B493) No. 2:</i>	Is the resistance less than 1 Ω ?	Go to step 10.	Repair the open circuit of harness between ECM connector and starter relay connector.
10 CHECK TRANSMISSION TYPE.	Is the transmission type CVT?	Go to step 11.	Go to step 14.
11 CHECK HARNESS BETWEEN STARTER RELAY AND INHIBITOR SWITCH CONNECTOR. 1) Turn the ignition switch to OFF. 2) Disconnect the connector from inhibitor switch. 3) Measure the resistance of harness between starter relay connector and inhibitor switch connector. <i>Connector & terminal</i> <i>(B493) No. 3 — (T7) No. 6:</i>	Is the resistance less than 1 Ω ?	Go to step 12.	Repair the harness and connector. NOTE: In this case, repair the following item: <ul style="list-style-type: none"> • Open circuit in harness between starter relay connector and inhibitor switch connector • Poor contact of coupling connector
12 CHECK HARNESS BETWEEN INHIBITOR SWITCH AND STARTER MOTOR. Measure the resistance of harness between the inhibitor switch connector and starter motor. <i>Connector & terminal</i> <i>(T7) No. 9 — (B14) No. 1:</i>	Is the resistance less than 1 Ω ?	Go to step 13.	Repair the harness and connector. NOTE: In this case, repair the following item: <ul style="list-style-type: none"> • Open circuit in harness between inhibitor switch connector and starter motor • Poor contact of coupling connector
13 CHECK INHIBITOR SWITCH. 1) Place the select lever in “P” range and “N” range. 2) Measure the resistance between inhibitor switch terminals. <i>Terminals</i> <i>No. 6 — No. 9:</i>	Is the resistance less than 1 Ω ?	Check the engine control module (ECM) power supply and ground line. <Ref. to EN(H4DO)(diag)-74, CHECK POWER SUPPLY AND GROUND LINE OF ENGINE CONTROL MODULE (ECM), Diagnostics for Engine Starting Failure.>	Replace the inhibitor switch. <Ref. to CVT-96, Inhibitor Switch.>

Diagnostics for Engine Starting Failure

ENGINE (DIAGNOSTICS)

Step	Check	Yes	No
<p>14 CHECK HARNESS BETWEEN STARTER RELAY AND STARTER MOTOR. Measure the resistance of harness between starter relay connector and starter motor. <i>Connector & terminal</i> <i>(B493) No. 3 — (B14) No. 1:</i></p>	<p>Is the resistance less than 1 Ω?</p>	<p>Check the engine control module (ECM) power supply and ground line. <Ref. to EN(H4DO)(diag)-74, CHECK POWER SUPPLY AND GROUND LINE OF ENGINE CONTROL MODULE (ECM), Diagnostics for Engine Starting Failure.></p>	<p>Repair the open circuit of the harness between starter relay connector and starter motor.</p>

Diagnostics for Engine Starting Failure

ENGINE (DIAGNOSTICS)

2. MODEL WITH PUSH BUTTON START

CAUTION:

After servicing or replacing faulty parts, perform Clear Memory Mode <Ref. to EN(H4DO)(diag)-59, Clear Memory Mode.>, and Inspection Mode <Ref. to EN(H4DO)(diag)-46, Inspection Mode.>.

WIRING DIAGRAM:

Engine electrical system, 2.5 L model (with push button start)<Ref. to WI-136, 2.5 L MODEL (WITH PUSH BUTTON START), WIRING DIAGRAM, Engine Electrical System.>

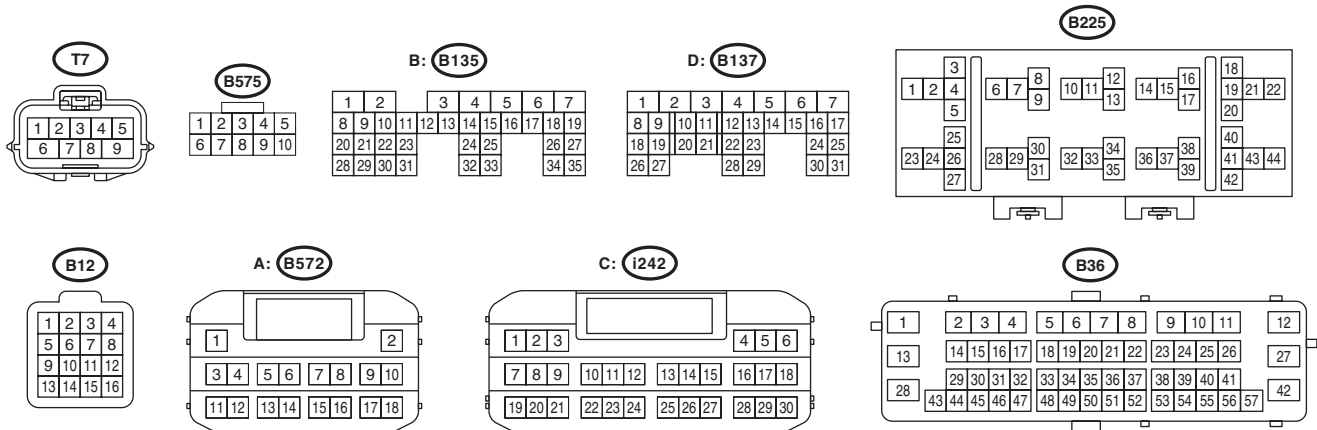
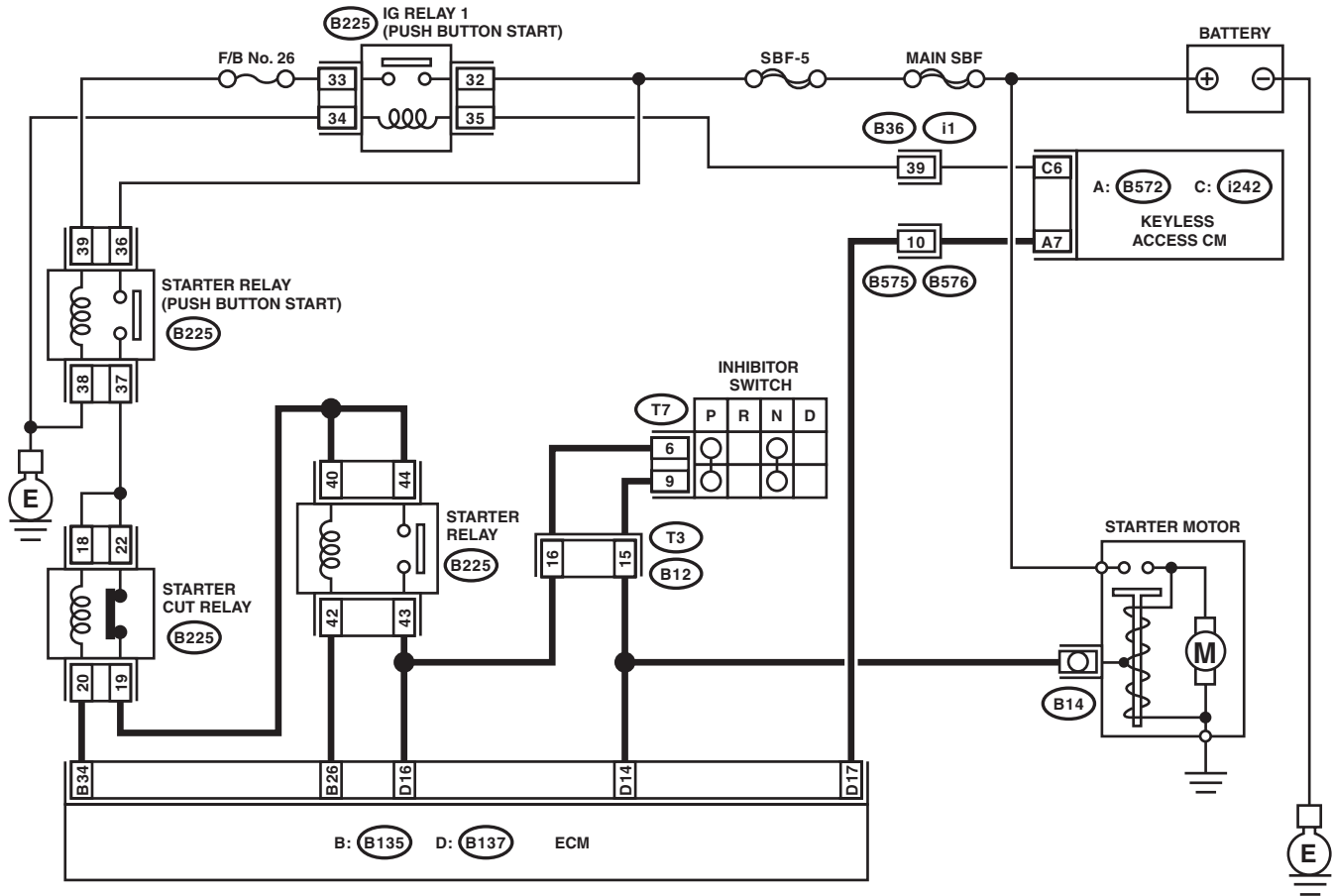

EN-09853

Diagnostics for Engine Starting Failure

ENGINE (DIAGNOSTICS)

Step	Check	Yes	No	
1	CHECK BATTERY. Check the battery. <Ref. to SC(H4DO)-51, Battery.>	Is the battery OK?	Go to step 2.	Charge or replace the battery. <Ref. to SC(H4DO)-51, Battery.>
2	CHECK OPERATION OF STARTER MOTOR.	Does the starter motor operate?	Go to step 3.	Go to step 4.
3	CHECK DTC.	Is DTC displayed?<Ref. to EN(H4DO)(diag)-45, OPERATION, Read Diagnostic Trouble Code (DTC).>	Check the appropriate DTC using the "List of Diagnostic Trouble Code (DTC)". <Ref. to EN(H4DO)(diag)-84, List of Diagnostic Trouble Code (DTC).>	Check ignition control system. <Ref. to EN(H4DO)(diag)-77, IGNITION CONTROL SYSTEM, Diagnostics for Engine Starting Failure.>
4	CHECK PUSH BUTTON IGNITION SWITCH. Press the push button ignition switch twice with the ignition OFF (ACC OFF). NOTE: Release the brake pedal.	Does the ignition turn to ON?	Go to step 5.	Check the push button start system. <Ref. to KPS(diag)-86, INSPECTION, General Diagnostic Table.>
5	CHECK PUSH BUTTON IGNITION SWITCH. 1) Depress the brake pedal. NOTE: Shift the select lever to "P" range. 2) Check the push button ignition switch indicator.	Does the indicator turn to green?	Go to step 6.	Check the brake signal circuit. <Ref. to CC(diag)-18, 12, Diagnostic Procedure with Cancel Code.>
6	CHECK START SWITCH SIGNAL. 1) Read the waveform of «Starter SW» using the Subaru Select Monitor. NOTE: For detailed operation procedures, refer to "READ CURRENT DATA FOR ENGINE". <Ref. to EN(H4DO)(diag)-38, Subaru Select Monitor.> 2) Press the push button ignition switch once with the brake pedal depressed.	Does waveform of the «Starter SW» occur?	Go to step 10.	Go to step 7.
7	CHECK HARNESS BETWEEN ECM AND KEYLESS ACCESS CM. 1) Turn the ignition to OFF. 2) Disconnect the connectors from ECM and keyless access CM. 3) Measure the resistance of harness between ECM connector and keyless access CM. Connector & terminal (B137) No. 17 — (B572) No. 7:	Is the resistance less than 1 Ω?	Go to step 8.	Repair the harness and connector. NOTE: In this case, repair the following item: • Open circuit of harness between ECM connector and keyless access CM connector • Poor contact of coupling connector
8	CHECK HARNESS BETWEEN ECM AND KEYLESS ACCESS CM. Measure the resistance between ECM connector and chassis ground. Connector & terminal (B137) No. 17 — Chassis ground:	Is the resistance 1 MΩ or more?	Go to step 9.	Repair the short circuit to ground in harness between ECM connector and keyless access CM connector.

Diagnostics for Engine Starting Failure

ENGINE (DIAGNOSTICS)

Step	Check	Yes	No
9 CHECK START SWITCH SIGNAL. 1) Connect the connector to ECM and keyless access CM. 2) Read the waveform of start switch signal using an oscilloscope. 3) Press the push button ignition switch once with the brake pedal depressed. Connector & terminal (B137) No. 17 (+) — Chassis ground (-):	Does waveform of the start switch signal occur?	Repair the poor contact of ECM connector.	Repair the poor contact of keyless access CM connector.
10 CHECK INPUT SIGNAL FOR STARTER MOTOR. 1) Turn the ignition to OFF. 2) Disconnect the connector from starter motor. 3) Place the select lever in "P" range or "N" range. 4) Press the push button ignition switch once with the brake pedal depressed. 5) Measure the voltage between the starter motor connector and the engine ground. Connector & terminal (B14) No. 1 (+) — Engine ground (-):	Is the voltage 10 V or more?	Check the starter motor. <Ref. to SC(H4DO)-7, Starter.>	Go to step 11.
11 CHECK IG RELAY 1 (PUSH BUTTON START) POWER SUPPLY. 1) Remove the IG relay 1 (push button start). 2) Turn the ignition to ON. 3) Measure the voltage between the IG relay 1 (push button start) connector and chassis ground. Connector & terminal (B225) No. 32 (+) — Chassis ground (-): (B225) No. 35 (+) — Chassis ground (-):	Is the voltage 10 V or more?	Go to step 12.	Check the following item and repair or replace if necessary. <ul style="list-style-type: none"> • Blown out of fuse • Open circuit or short circuit to ground in harness between IG relay 1 (push button start) connector and keyless access CM connector • Open circuit or short circuit to ground in harness between IG relay 1 (push button start) connector and battery • Poor contact of coupling connector
12 CHECK HARNESS BETWEEN IG RELAY 1 (PUSH BUTTON START) CONNECTOR AND CHASSIS GROUND. 1) Turn the ignition to OFF. 2) Measure the resistance of harness between the IG relay 1 (push button start) connector and chassis ground. Connector & terminal (B225) No. 34 — Chassis ground:	Is the resistance less than 5 Ω?	Go to step 13.	Repair the open circuit in harness between the IG relay 1 (push button start) connector and chassis ground.

Diagnostics for Engine Starting Failure

ENGINE (DIAGNOSTICS)

Step	Check	Yes	No
<p>13 CHECK IG RELAY 1 (PUSH BUTTON START).</p> <p>1) Connect the battery to IG relay 1 (push button start) terminals No. 34 and No. 35.</p> <p>2) Measure the resistance between IG relay 1 (push button start) terminals.</p> <p>Terminals No. 32 — No. 33:</p>	Is the resistance less than 1 Ω ?	Go to step 14.	Replace the IG relay 1 (push button start). <Ref. to SL-115, IG Relay1 (Push Button Start).>
<p>14 CHECK STARTER RELAY (PUSH BUTTON START) POWER SUPPLY.</p> <p>1) Install the IG relay 1 (push button start).</p> <p>2) Remove the starter relay (push button start).</p> <p>3) Turn the ignition to ON.</p> <p>4) Measure the voltage between starter relay (push button start) connector and chassis ground.</p> <p>Connector & terminal (B225) No. 36 (+) — Chassis ground (-): (B225) No. 39 (+) — Chassis ground (-):</p>	Is the voltage 10 V or more?	Go to step 15.	<p>Check the following item and repair or replace if necessary.</p> <ul style="list-style-type: none"> • Blown out of fuse (F/B No. 26) • Open circuit or short circuit to ground in harness between starter relay (push button start) connector and IG relay 1 (push button start) connector • Open circuit or short circuit to ground in harness between starter relay (push button start) connector and battery
<p>15 CHECK HARNESS BETWEEN STARTER RELAY (PUSH BUTTON START) CONNECTOR AND CHASSIS GROUND.</p> <p>1) Turn the ignition to OFF.</p> <p>2) Measure the resistance of harness between starter relay (push button start) connector and chassis ground.</p> <p>Connector & terminal (B225) No. 38 — Chassis ground:</p>	Is the resistance less than 5 Ω ?	Go to step 16.	Repair the open circuit in harness between starter relay (push button start) connector and chassis ground.
<p>16 CHECK STARTER RELAY (PUSH BUTTON START).</p> <p>1) Connect the battery to starter relay (push button start) terminals No. 38 and No. 39.</p> <p>2) Measure the resistance between starter relay (push button start) terminals.</p> <p>Terminals No. 36 — No. 37:</p>	Is the resistance less than 1 Ω ?	Go to step 17.	Replace the starter relay (push button start). <Ref. to SL-113, Starter Relay (Push Button Start).>
<p>17 CHECK HARNESS BETWEEN STARTER RELAY (PUSH BUTTON START) CONNECTOR AND STARTER CUT RELAY CONNECTOR.</p> <p>1) Remove the starter cut relay.</p> <p>2) Measure the resistance of harness between starter relay (push button start) connector and starter cut relay connector.</p> <p>Connector & terminal (B225) No. 37 — (B225) No. 18: (B225) No. 37 — (B225) No. 22:</p>	Is the resistance less than 1 Ω ?	Go to step 18.	Repair the open circuit in harness between starter relay (push button start) connector and starter cut relay connector.

Diagnostics for Engine Starting Failure

ENGINE (DIAGNOSTICS)

Step	Check	Yes	No
18 CHECK HARNESS BETWEEN ECM AND STARTER CUT RELAY CONNECTOR. 1) Disconnect the connector from ECM. 2) Measure the resistance between starter cut relay connector and chassis ground. <i>Connector & terminal</i> <i>(B225) No. 20 — Chassis ground:</i>	Is the resistance 1 M Ω or more?	Go to step 19.	Repair the short circuit to ground in harness between ECM connector and starter cut relay connector.
19 CHECK STARTER CUT RELAY. Measure the resistance between starter cut relay terminals. <i>Terminals</i> <i>No. 19 — No. 22:</i>	Is the resistance less than 1 Ω ?	Go to step 20.	Replace the starter cut relay. <Ref. to SL-121, Starter Cut Relay.>
20 CHECK HARNESS BETWEEN STARTER CUT RELAY CONNECTOR AND STARTER RELAY CONNECTOR. 1) Remove the starter relay. 2) Measure the resistance of harness between starter cut relay connector and starter relay connector. <i>Connector & terminal</i> <i>(B225) No. 19 — (B225) No. 40:</i> <i>(B225) No. 19 — (B225) No. 44:</i>	Is the resistance less than 1 Ω ?	Go to step 21.	Repair the open circuit in harness between starter cut relay connector and starter relay connector.
21 CHECK HARNESS BETWEEN ECM AND STARTER RELAY CONNECTOR. Measure the resistance of harness between ECM connector and starter relay connector. <i>Connector & terminal</i> <i>(B135) No. 26 — (B225) No. 42:</i>	Is the resistance less than 1 Ω ?	Go to step 22.	Repair the open circuit of harness between ECM connector and starter relay connector.
22 CHECK STARTER RELAY. 1) Connect the battery to starter relay terminals No. 40 and No. 42. 2) Measure the resistance between starter relay terminals. <i>Terminals</i> <i>No. 43 — No. 44:</i>	Is the resistance less than 1 Ω ?	Go to step 23.	Replace the starter relay. <Ref. to EN(H4DO)(diag)-9, LOCATION, Electrical Component Location.>
23 CHECK HARNESS BETWEEN STARTER RELAY CONNECTOR AND INHIBITOR SWITCH CONNECTOR. 1) Disconnect the connector from inhibitor switch. 2) Measure the resistance of harness between starter relay connector and inhibitor switch connector. <i>Connector & terminal</i> <i>(B225) No. 43 — (T7) No. 6:</i>	Is the resistance less than 1 Ω ?	Go to step 24.	Repair the harness and connector. NOTE: In this case, repair the following item: • Open circuit in harness between starter relay connector and inhibitor switch connector • Poor contact of coupling connector
24 CHECK INHIBITOR SWITCH. 1) Place the select lever in "P" range or "N" range. 2) Measure the resistance between inhibitor switch terminals. <i>Terminals</i> <i>No. 6 — No. 9:</i>	Is the resistance less than 1 Ω ?	Go to step 25.	Replace the inhibitor switch. <Ref. to CVT-96, Inhibitor Switch.>

Diagnostics for Engine Starting Failure

ENGINE (DIAGNOSTICS)

Step	Check	Yes	No
<p>25 CHECK HARNESS BETWEEN ECM AND INHIBITOR SWITCH CONNECTOR.</p> <p>1) Disconnect the connector from ECM. 2) Measure the resistance of harness between ECM connector and inhibitor switch connector.</p> <p>Connector & terminal (B137) No. 16 — (T7) No. 6:</p>	Is the resistance less than 1 Ω?	Go to step 26.	<p>Repair the harness and connector.</p> <p>NOTE: In this case, repair the following item:</p> <ul style="list-style-type: none"> • Open circuit in harness between ECM connector and inhibitor switch connector • Poor contact of coupling connector
<p>26 CHECK NEUTRAL POSITION SWITCH SIGNAL.</p> <p>1) Connect all relays and connectors to their proper positions. 2) Read the value of «Neutral Position Switch» using the Subaru Select Monitor.</p> <p>NOTE: For detailed operation procedures, refer to “READ CURRENT DATA FOR ENGINE”. <Ref. to EN(H4DO)(diag)-38, Subaru Select Monitor.></p> <p>3) Turn the ignition to ON. 4) Place the select lever in “P” range or “N” range.</p>	Is «Neutral» displayed?	Check the engine control module (ECM) power supply and ground line. <Ref. to EN(H4DO)(diag)-74, CHECK POWER SUPPLY AND GROUND LINE OF ENGINE CONTROL MODULE (ECM), Diagnostics for Engine Starting Failure.>	<p>Repair the harness and connector.</p> <p>NOTE: In this case, repair the following item:</p> <ul style="list-style-type: none"> • Open circuit in harness between inhibitor switch connector and starter motor connector • Poor contact of coupling connector

Diagnostics for Engine Starting Failure

ENGINE (DIAGNOSTICS)

C: CHECK POWER SUPPLY AND GROUND LINE OF ENGINE CONTROL MODULE (ECM)

CAUTION:

After servicing or replacing faulty parts, perform Clear Memory Mode <Ref. to EN(H4DO)(diag)-59, OPERATION, Clear Memory Mode.>, and Inspection Mode <Ref. to EN(H4DO)(diag)-46, PROCEDURE, Inspection Mode.>.

Diagnostics for Engine Starting Failure

WIRING DIAGRAM:

- Engine electrical system, 2.5 L model (without push button start) <Ref. to WI-122, 2.5 L MODEL (WITHOUT PUSH BUTTON START), WIRING DIAGRAM, Engine Electrical System.>
- Engine electrical system, 2.5 L model (with push button start) <Ref. to WI-136, 2.5 L MODEL (WITH PUSH BUTTON START), WIRING DIAGRAM, Engine Electrical System.>

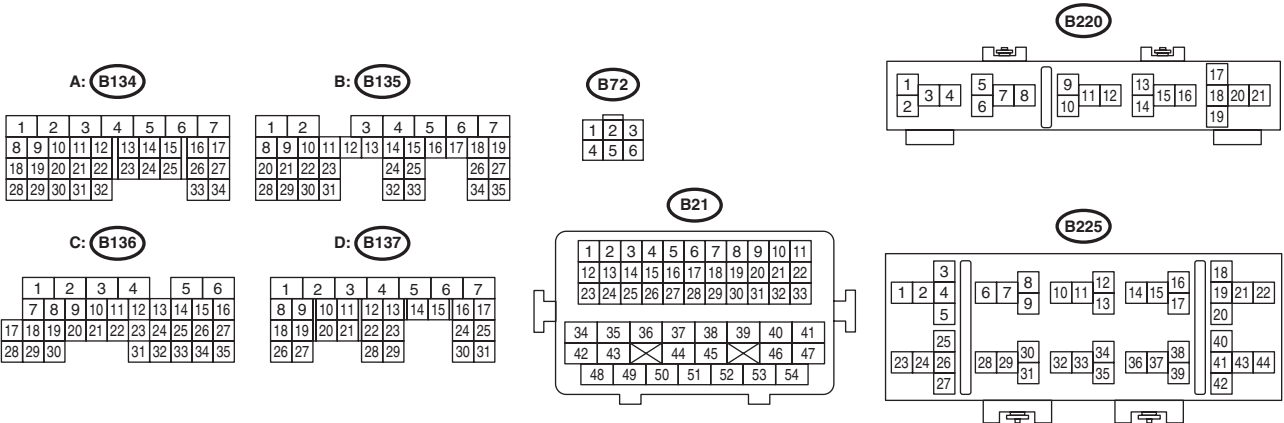
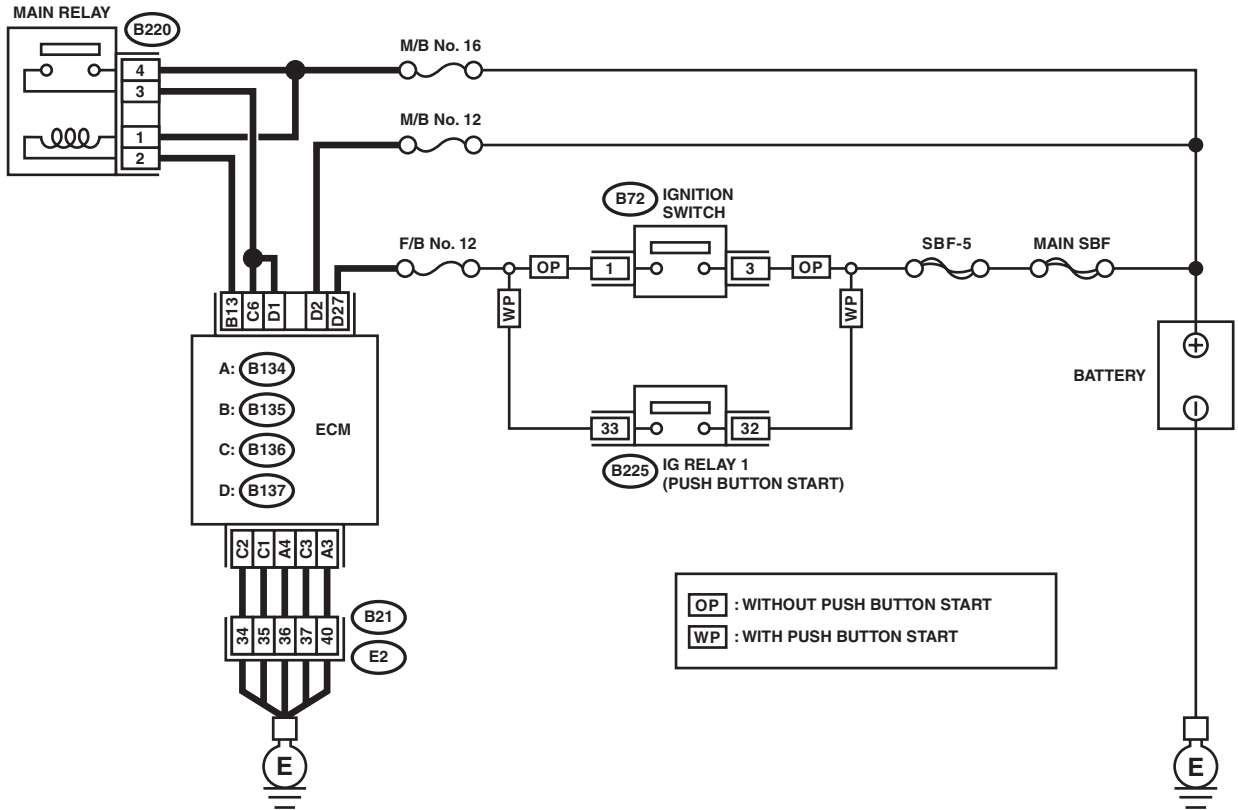

Diagnostics for Engine Starting Failure

ENGINE (DIAGNOSTICS)

Step	Check	Yes	No
1 CHECK MAIN RELAY. 1) Turn the ignition switch to OFF. 2) Remove the main relay. 3) Connect the battery to main relay terminals No. 1 and No. 2. 4) Measure the resistance between main relay terminals. Terminals No. 3 — No. 4:	Is the resistance less than 1 Ω ?	Go to step 2.	Replace the main relay. <Ref. to FU(H4DO)-103, Main Relay.>
2 CHECK GROUND CIRCUIT FOR ECM. 1) Disconnect the connector from ECM. 2) Measure the resistance of harness between ECM connector and chassis ground. Connector & terminal (B134) No. 3 — Chassis ground: (B134) No. 4 — Chassis ground: (B136) No. 1 — Chassis ground: (B136) No. 2 — Chassis ground: (B136) No. 3 — Chassis ground:	Is the resistance less than 5 Ω ?	Go to step 3.	Repair the harness and connector. NOTE: In this case, repair the following item: <ul style="list-style-type: none"> • Open circuit of harness between ECM connector and engine ground terminal • Poor contact of coupling connector
3 CHECK INPUT VOLTAGE OF ECM. 1) Turn the ignition switch to ON. 2) Measure the voltage between ECM connector and chassis ground. Connector & terminal (B137) No. 2 (+) — Chassis ground (-): (B137) No. 27 (+) — Chassis ground (-):	Is the voltage 10 V or more?	Go to step 4.	Repair the open or ground short circuit of harness of power supply circuit.
4 CHECK INPUT VOLTAGE OF MAIN RELAY. Measure the voltage between main relay connector and chassis ground. Connector & terminal (B220) No. 1 (+) — Chassis ground (-): (B220) No. 4 (+) — Chassis ground (-):	Is the voltage 10 V or more?	Go to step 5.	Repair the open or ground short circuit of harness of power supply circuit.
5 CHECK INPUT VOLTAGE OF ECM. 1) Turn the ignition switch to OFF. 2) Install the main relay. 3) Turn the ignition switch to ON. 4) Measure the voltage between ECM connector and chassis ground. Connector & terminal (B135) No. 13 (+) — Chassis ground (-):	Is the voltage 10 V or more?	Go to step 6.	Repair the open circuit of harness between ECM connector and main relay connector.
6 CHECK INPUT VOLTAGE OF ECM. 1) Turn the ignition switch to OFF. 2) Connect the connector to ECM. 3) Turn the ignition switch to ON. 4) Measure the voltage between ECM connector and chassis ground. Connector & terminal (B136) No. 6 (+) — Chassis ground (-): (B137) No. 1 (+) — Chassis ground (-):	Is the voltage 10 V or more?	Check ignition control system. <Ref. to EN(H4DO)(diag)-77, IGNITION CONTROL SYSTEM, Diagnostics for Engine Starting Failure.>	Repair the harness and connector. NOTE: In this case, repair the following item: <ul style="list-style-type: none"> • Open circuit in harness between ECM connector and main relay connector • Poor contact of main relay connector • Poor contact of ECM connector

D: IGNITION CONTROL SYSTEM

CAUTION:

After servicing or replacing faulty parts, perform Clear Memory Mode <Ref. to EN(H4DO)(diag)-59, Clear Memory Mode.>, and Inspection Mode <Ref. to EN(H4DO)(diag)-46, Inspection Mode.>.

WIRING DIAGRAM:

- Engine electrical system, 2.5 L model (without push button start)<Ref. to WI-122, 2.5 L MODEL (WITHOUT PUSH BUTTON START), WIRING DIAGRAM, Engine Electrical System.>
- Engine electrical system, 2.5 L model (with push button start)<Ref. to WI-136, 2.5 L MODEL (WITH PUSH BUTTON START), WIRING DIAGRAM, Engine Electrical System.>

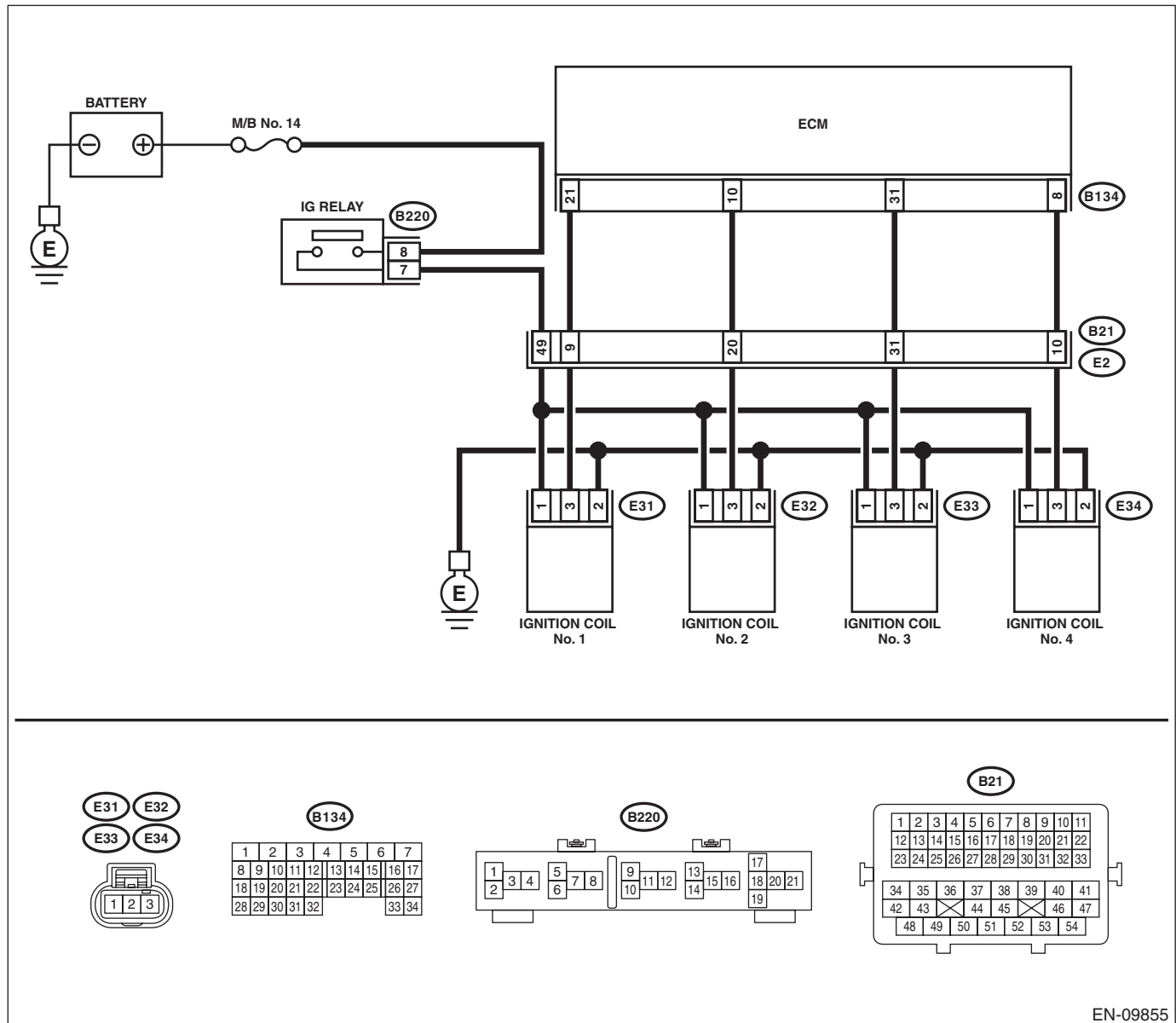

EN-09855

Step	Check	Yes	No
1 CHECK SPARK PLUG CONDITION. 1) Remove the spark plug. <Ref. to IG(H4DO)-4, REMOVAL, Spark Plug.> 2) Check the spark plug condition. <Ref. to IG(H4DO)-6, INSPECTION, Spark Plug.>	Is the spark plug condition normal?	Go to step 2.	Replace the spark plug. <Ref. to IG(H4DO)-4, Spark Plug.>

Diagnostics for Engine Starting Failure

ENGINE (DIAGNOSTICS)

Step	Check	Yes	No
<p>2 CHECK IGNITION SYSTEM FOR SPARKS. 1) Connect the spark plug to ignition coil. 2) Release the fuel pressure. <Ref. to FU(H4DO)-109, RELEASING OF FUEL PRESSURE, PROCEDURE, Fuel.> 3) Contact the spark plug thread portion to engine. 4) While opening the throttle valve fully, crank the engine to check that spark occurs at each cylinder.</p>	Does spark occur at each cylinder?	Check fuel pump system. <Ref. to EN(H4DO)(diag)-79, FUEL PUMP CIRCUIT, Diagnostics for Engine Starting Failure.>	Go to step 3.
<p>3 CHECK IGNITION COIL POWER SUPPLY CIRCUIT. 1) Turn the ignition switch to OFF. 2) Disconnect the connector from ignition coil. 3) Turn the ignition switch to ON. 4) Measure the voltage between ignition coil connector and engine ground. Connector & terminal <i>(E31) No. 1 (+) — Engine ground (-):</i> <i>(E32) No. 1 (+) — Engine ground (-):</i> <i>(E33) No. 1 (+) — Engine ground (-):</i> <i>(E34) No. 1 (+) — Engine ground (-):</i></p>	Is the voltage 10 V or more?	Go to step 4.	Repair the harness and connector. NOTE: In this case, repair the following item: <ul style="list-style-type: none"> • Open circuit or short circuit to ground in harness of power supply circuit • Poor contact of coupling connector • Blown out of fuse
<p>4 CHECK HARNESS OF IGNITION COIL GROUND CIRCUIT. 1) Turn the ignition switch to OFF. 2) Measure the resistance of harness between ignition coil connector and engine ground. Connector & terminal <i>(E31) No. 2 — Engine ground:</i> <i>(E32) No. 2 — Engine ground:</i> <i>(E33) No. 2 — Engine ground:</i> <i>(E34) No. 2 — Engine ground:</i></p>	Is the resistance less than 5 Ω?	Go to step 5.	Repair the open circuit in harness between ignition coil connector and engine grounding terminal.
<p>5 CHECK HARNESS BETWEEN ECM AND IGNITION COIL CONNECTOR. 1) Disconnect the connector from ECM. 2) Measure the resistance of harness between ECM connector and ignition coil connector. Connector & terminal <i>(B134) No. 21 — (E31) No. 3:</i> <i>(B134) No. 10 — (E32) No. 3:</i> <i>(B134) No. 31 — (E33) No. 3:</i> <i>(B134) No. 8 — (E34) No. 3:</i></p>	Is the resistance less than 1 Ω?	Go to step 6.	Repair the harness and connector. NOTE: In this case, repair the following item: <ul style="list-style-type: none"> • Open circuit of harness between ECM connector and the ignition coil connector • Poor contact of coupling connector
<p>6 CHECK HARNESS BETWEEN ECM AND IGNITION COIL CONNECTOR. Measure the resistance of harness between ECM connector and engine ground. Connector & terminal: <i>(B134) No. 21 — Engine ground:</i> <i>(B134) No. 10 — Engine ground:</i> <i>(B134) No. 31 — Engine ground:</i> <i>(B134) No. 8 — Engine ground:</i></p>	Is the resistance 1 MΩ or more?	Go to step 7.	Repair the ground short circuit of harness between ECM connector and ignition coil connector.
<p>7 CHECK FOR POOR CONTACT. Check for poor contact of ECM connector.</p>	Is there poor contact of ECM connector?	Repair the poor contact of ECM connector.	Replace the ignition coil. <Ref. to IG(H4DO)-9, Ignition Coil.>

E: FUEL PUMP CIRCUIT

CAUTION:

After servicing or replacing faulty parts, perform Clear Memory Mode <Ref. to EN(H4DO)(diag)-59, OPERATION, Clear Memory Mode.>, and Inspection Mode <Ref. to EN(H4DO)(diag)-46, PROCEDURE, Inspection Mode.>.

WIRING DIAGRAM:

- Engine electrical system, 2.5 L model (without push button start)<Ref. to WI-122, 2.5 L MODEL (WITHOUT PUSH BUTTON START), WIRING DIAGRAM, Engine Electrical System.>
- Engine electrical system, 2.5 L model (with push button start)<Ref. to WI-136, 2.5 L MODEL (WITH PUSH BUTTON START), WIRING DIAGRAM, Engine Electrical System.>

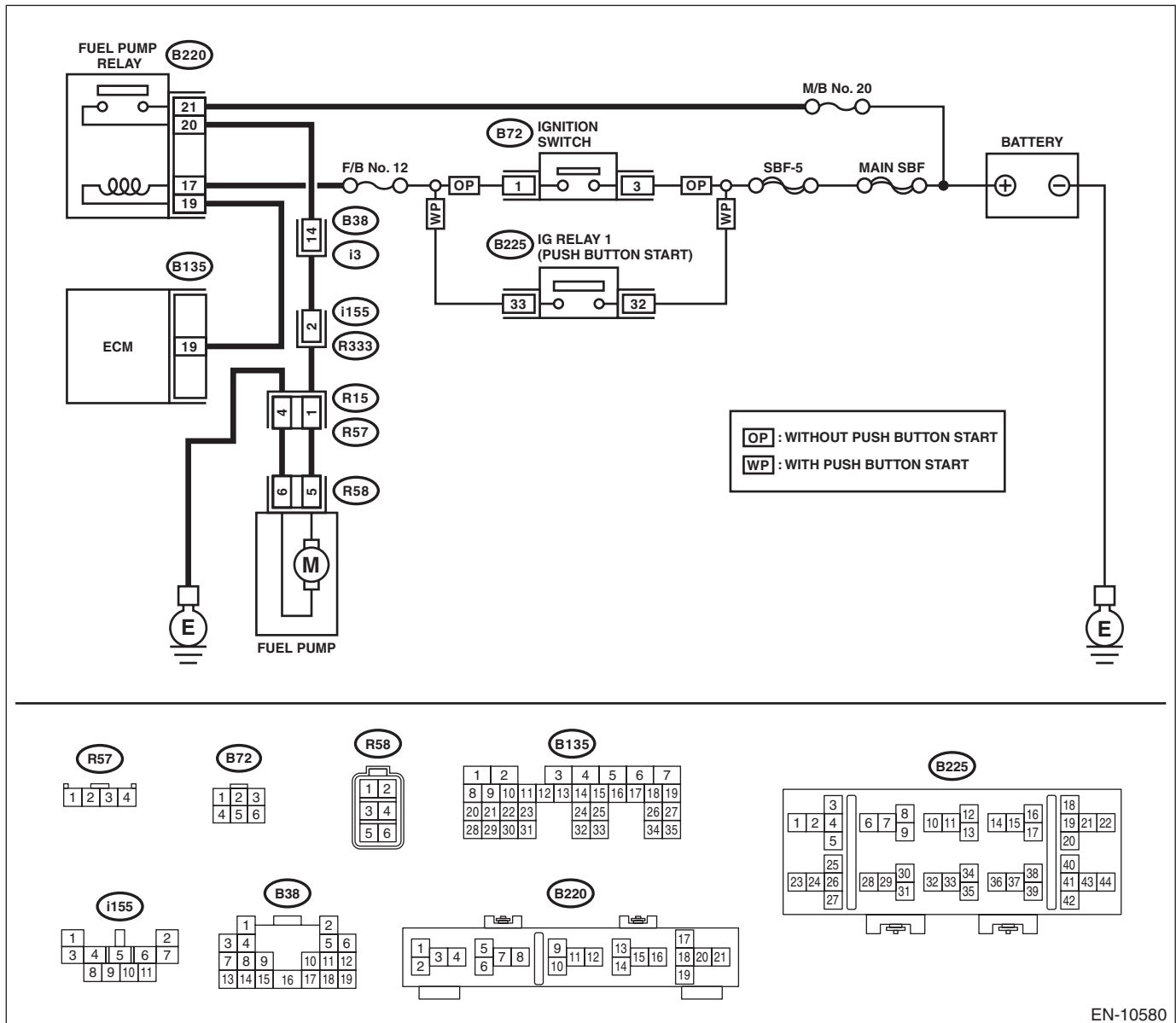

Diagnostics for Engine Starting Failure

ENGINE (DIAGNOSTICS)

Step	Check	Yes	No
<p>1 CHECK OPERATING SOUND OF FUEL PUMP. Check if the fuel pump operates for two seconds when turning the ignition switch to ON.</p> <p>NOTE: Fuel pump operation can be executed using the Subaru Select Monitor. For detailed procedures, refer to "SYSTEM OPERATION CHECK MODE". <Ref. to EN(H4DO)(diag)-60, System Operation Check Mode.></p>	Does the fuel pump emit operating sound?	Check the fuel injector circuit. <Ref. to EN(H4DO)(diag)-82, FUEL INJECTOR CIRCUIT, Diagnostics for Engine Starting Failure.>	Go to step 2.
<p>2 CHECK GROUND CIRCUIT OF FUEL PUMP. 1) Turn the ignition switch to OFF. 2) Remove the fuel pump access hole lid. 3) Disconnect the connector from fuel pump. 4) Measure the resistance of harness between fuel pump and chassis ground.</p> <p>Connector & terminal (R58) No. 6 — Chassis ground:</p>	Is the resistance less than 5 Ω ?	Go to step 3.	Repair the harness and connector. NOTE: In this case, repair the following item: • Open circuit in harness between fuel pump connector and chassis grounding terminal • Poor contact of coupling connector
<p>3 CHECK POWER SUPPLY TO FUEL PUMP. 1) Turn the ignition switch to ON. 2) Measure the voltage of power supply circuit between fuel pump connector and chassis ground.</p> <p>Connector & terminal (R58) No. 5 (+) — Chassis ground (-):</p>	Is the voltage 10 V or more?	Replace the fuel pump. <Ref. to FU(H4DO)-139, Fuel Pump.>	Go to step 4.
<p>4 CHECK HARNESS BETWEEN FUEL PUMP AND FUEL PUMP RELAY CONNECTOR. 1) Turn the ignition switch to OFF. 2) Measure the resistance of harness between fuel pump connector and fuel pump relay connector.</p> <p>Connector & terminal (R58) No. 5 — (B220) No. 20:</p>	Is the resistance less than 1 Ω ?	Go to step 5.	Repair the harness and connector. NOTE: In this case, repair the following item: • Open circuit in harness between fuel pump connector and fuel pump relay connector • Poor contact of coupling connector
<p>5 CHECK HARNESS BETWEEN FUEL PUMP AND FUEL PUMP RELAY CONNECTOR. Measure the resistance of harness between fuel pump connector and fuel pump relay connector.</p> <p>Connector & terminal (R58) No. 5 — Chassis ground:</p>	Is the resistance 1 M Ω or more?	Go to step 6.	Repair the short circuit to ground in harness between fuel pump connector and fuel pump relay connector.
<p>6 CHECK FUEL PUMP RELAY. 1) Remove the fuel pump relay. 2) Connect the battery to fuel pump relay terminals No. 17 and No. 19. 3) Measure the resistance between fuel pump relay terminals.</p> <p>Terminals No. 20 — No. 21:</p>	Is the resistance less than 1 Ω ?	Go to step 7.	Replace the fuel pump relay. <Ref. to FU(H4DO)-105, Fuel Pump Relay.>

Diagnostics for Engine Starting Failure

ENGINE (DIAGNOSTICS)

Step	Check	Yes	No
7 CHECK HARNESS BETWEEN ECM AND FUEL PUMP RELAY CONNECTOR. 1) Disconnect the connector from ECM. 2) Measure the resistance of harness between ECM connector and fuel pump relay connector. Connector & terminal (B135) No. 19 — (B220) No. 19:	Is the resistance less than 1 Ω ?	Go to step 8 .	Repair the open circuit of harness between ECM connector and fuel pump relay connector.
8 CHECK POWER SUPPLY OF FUEL PUMP RELAY. 1) Turn the ignition switch to ON. 2) Measure the voltage between fuel pump relay connector and chassis ground. Connector & terminal (B220) No. 17 (+) — Chassis ground (-): (B220) No. 21 (+) — Chassis ground (-):	Is the voltage 10 V or more?	Repair the poor contact of ECM connector.	Repair the open or ground short circuit of harness of power supply circuit.

Diagnostics for Engine Starting Failure

ENGINE (DIAGNOSTICS)

F: FUEL INJECTOR CIRCUIT

CAUTION:

- Check or repair only faulty parts.
- After servicing or replacing faulty parts, perform Clear Memory Mode <Ref. to EN(H4DO)(diag)-59, OPERATION, Clear Memory Mode.>, and Inspection Mode <Ref. to EN(H4DO)(diag)-46, PROCEDURE, Inspection Mode.>.

WIRING DIAGRAM:

- Engine electrical system, 2.5 L model (without push button start)<Ref. to WI-122, 2.5 L MODEL (WITHOUT PUSH BUTTON START), WIRING DIAGRAM, Engine Electrical System.>
- Engine electrical system, 2.5 L model (with push button start)<Ref. to WI-136, 2.5 L MODEL (WITH PUSH BUTTON START), WIRING DIAGRAM, Engine Electrical System.>

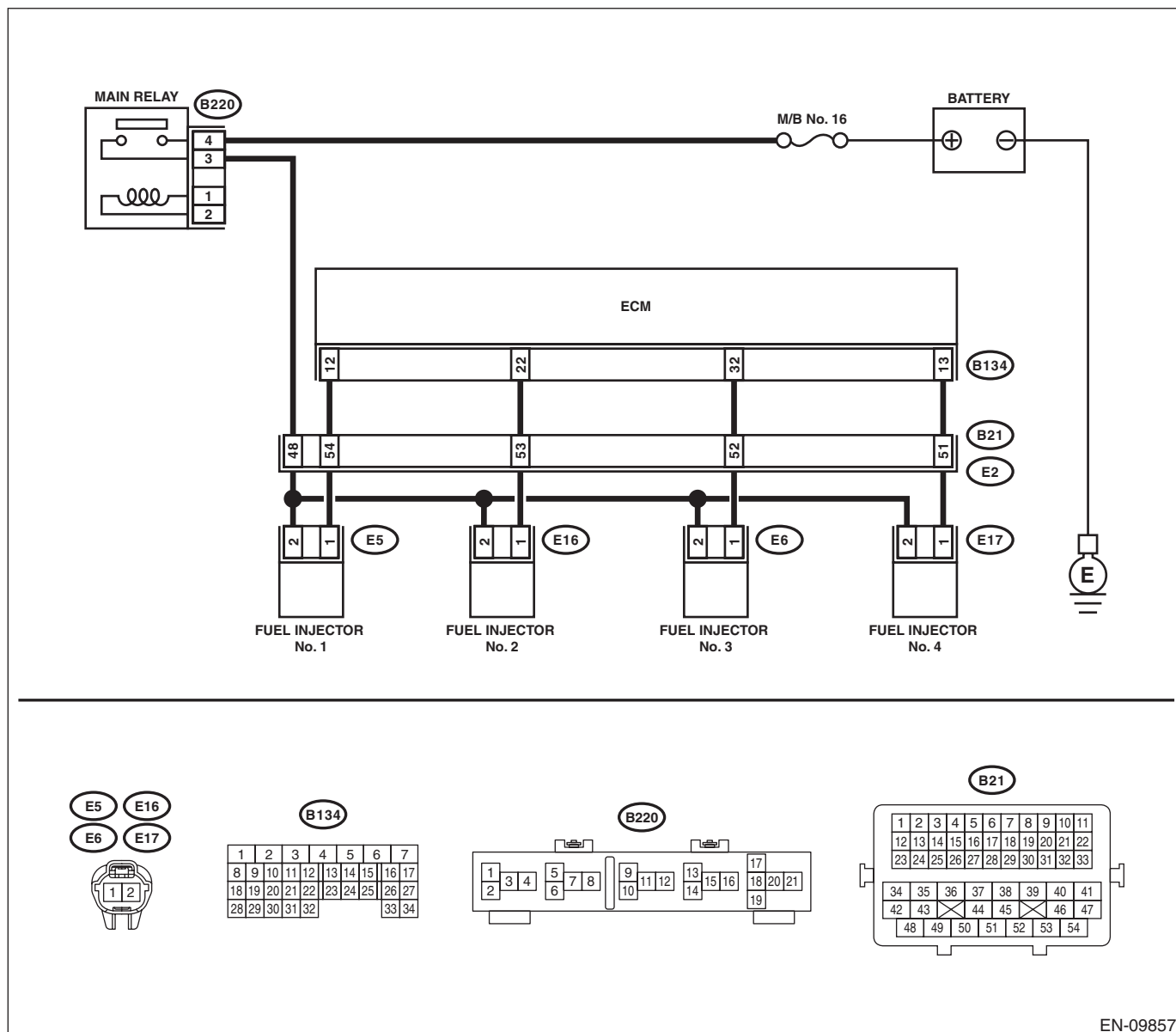

EN-09857

Step	Check	Yes	No	
1	<p>CHECK OPERATION OF EACH FUEL INJECTOR.</p> <p>While cranking the engine, check each fuel injector emits operating sound. Use a sound scope or attach a screwdriver to the injector to listen to sounds for this check.</p>	Does the fuel injector emit operating sound?	Check the fuel pressure. <Ref. to ME(H4DO)-32, INSPECTION, Fuel Pressure.>	Go to step 2.

Diagnostics for Engine Starting Failure

ENGINE (DIAGNOSTICS)

Step	Check	Yes	No
<p>2 CHECK POWER SUPPLY TO EACH FUEL INJECTOR.</p> <p>1) Turn the ignition switch to OFF. 2) Disconnect the connector from fuel injector. 3) Turn the ignition switch to ON. 4) Measure the power supply voltage between fuel injector terminal and engine ground.</p> <p>Connector & terminal #1 (E5) No. 2 (+) — Engine ground (-): #2 (E16) No. 2 (+) — Engine ground (-): #3 (E6) No. 2 (+) — Engine ground (-): #4 (E17) No. 2 (+) — Engine ground (-):</p>	Is the voltage 10 V or more?	Go to step 3.	Repair the harness and connector. NOTE: In this case, repair the following item: • Open circuit in harness between main relay connector and fuel injector connector • Poor contact of main relay connector • Poor contact of coupling connector
<p>3 CHECK HARNESS BETWEEN ECM AND FUEL INJECTOR CONNECTOR.</p> <p>1) Turn the ignition switch to OFF. 2) Disconnect the connector from ECM. 3) Measure the resistance of harness between ECM connector and fuel injector connector.</p> <p>Connector & terminal #1 (B134) No. 12 — (E5) No. 1: #2 (B134) No. 22 — (E16) No. 1: #3 (B134) No. 32 — (E6) No. 1: #4 (B134) No. 13 — (E17) No. 1:</p>	Is the resistance less than 1 Ω?	Go to step 4.	Repair the harness and connector. NOTE: In this case, repair the following item: • Open circuit in harness between ECM connector and fuel injector connector • Poor contact of coupling connector
<p>4 CHECK HARNESS BETWEEN ECM AND FUEL INJECTOR CONNECTOR.</p> <p>Measure the resistance between ECM connector and chassis ground.</p> <p>Connector & terminal #1 (B134) No. 12 — Chassis ground: #2 (B134) No. 22 — Chassis ground: #3 (B134) No. 32 — Chassis ground: #4 (B134) No. 13 — Chassis ground:</p>	Is the resistance 1 MΩ or more?	Go to step 5.	Repair the short circuit to ground in harness between ECM connector and fuel injector connector.
<p>5 CHECK EACH FUEL INJECTOR.</p> <p>Measure the resistance between each fuel injector terminals.</p> <p>Terminals No. 1 — No. 2:</p>	Is the resistance 5 — 20 Ω?	Go to step 6.	Replace the faulty fuel injector. <Ref. to FU(H4DO)-77, Fuel Injector.>
<p>6 CHECK FOR POOR CONTACT.</p> <p>Check for poor contact of ECM connector.</p>	Is there poor contact of ECM connector?	Repair the poor contact of ECM connector.	Inspection using “General Diagnostic Table” <Ref. to EN(H4DO)(diag)-346, INSPECTION, General Diagnostic Table.>